

**Design & Construction Planning of Rapid Bridge Deck Replacement
Systems for I-59 Bridges at Collinsville, AL**

by

Bryan Edward Harvey

A thesis submitted to the Graduate Faculty of
Auburn University
in partial fulfillment of the
requirements for the Degree of
Master of Science

Auburn, Alabama
December 12, 2011

Copyright 2011 by Bryan E. Harvey

Approved by

Hassan H. Abbas, Co-Chair, Assistant Professor of Civil Engineering
G. Ed Ramey, Co-chair, Professor Emeritus
Robert W. Barnes, James J. Mallett Associate Professor of Civil Engineering

Abstract

Many bridges in the Birmingham area have deteriorated decks that need to be rehabilitated or replaced. Several of these are major interstate bridges that carry large volumes of traffic. Rehabilitation or replacement of the decks of these highly traveled bridges must be done in a rapid manner to minimize interruption to traffic. Previous experience has shown that deck rehabilitation only serves as a temporary solution and is not the best option for decks that have supporting components with good remaining service life. Therefore, rapid replacement of the deteriorated decks is the most feasible option. Developing rapid replacement schemes is the primary focus of this report. Four rapid deck replacement systems are investigated and sufficient joint and connection details are determined for use on two test bridges. Of the four rapid deck replacement systems, two are precast deck systems, which are to be installed on one of the test bridges, and two are cast-in-place deck systems, which are to be installed on the other test bridge. The precast deck systems are capable of being installed during over-night work periods while the cast-in-place deck systems are capable of being installed during weekend work periods. Construction sequences were developed for each of the deck systems to understand the loads that the decks are subjected to. Each deck system has been designed to resist these loads. The implementation of the deck systems on the test bridges will assist in determining which deck system is the best option for replacement of the deteriorated decks in the Birmingham area.

Acknowledgments

This research could not have been possible without the assistance of many people. The author gives his utmost gratitude to the Alabama Department of Transportation (ALDOT), Auburn University, and the many others who have given their time, expert opinions, and guidance in making this study a success. The financial support provided by the ALDOT and Auburn University is also greatly appreciated. Particular thanks are given to Buddy Black, Tim Colquett, Berhanu Woldemichael, and Robert King of the ALDOT, Gil Graham and Gene Gilmore of Bailey Bridges Inc., Mark Kaczinski of D.S. Brown, and Hassan Abbas, George Ramey, and Robert Barnes of Auburn University.

Table of Contents

Abstract	ii
Acknowledgements	iii
List of Tables	viii
List of Figures	x
List of Abbreviations	xvi
1. Introduction.....	1
1.1. Motivation.....	1
1.2. Objective.....	2
1.3. Scope & Approach.....	3
1.4. Work Plan	3
1.5. Organization.....	4
2. Background and Review of Literature.....	5
2.1. Background.....	5
2.2. Literature Review	6
2.2.1. General.....	6
2.2.2. Exodermic Cast-in-Place Deck System	7
2.2.3. Steel Grid Partial-Depth Cast-in-Place Deck System.....	8
2.2.4. Exodermic Precast Deck System	9
2.2.5. NCHRP Full-Depth Precast Deck System.....	9
2.2.6. Barrier Rails	12

3.	Description of the Collinsville Bridges.....	13
3.1.	General.....	13
3.2.	Bridge Photos.....	18
4.	Description of Proposed Modifications	22
4.1.	Bridge Widening.....	22
4.2.	Proposed Deck Systems.....	22
4.2.1.	NCHRP Full-Depth Precast Deck System.....	25
4.2.2.	Exodermic Precast Deck System	31
4.2.3.	Exodermic Cast-in-Place Deck System	36
4.2.4.	Steel Grid Partial-depth Cast-in-Place Deck System.....	41
4.3.	Proposed Barrier Rail.....	46
5.	Proposed Sequence of Deck Replacement.....	56
5.1.	General.....	56
5.2.	Stage I Construction.....	57
5.3.	Stage II Construction	62
5.4.	Stage III Construction.....	68
5.5.	Stage IV Construction.....	72
5.6.	Remarks	80
5.7.	Comparison to ALDOT’s Accepted Sequence of Construction.....	81

6. Design of Deck Elements.....	83
6.1. General.....	83
6.1.1. Load Calculations	83
6.1.2. Deck Design.....	98
6.1.3. Deck Overhang Design	98
6.1.4. Connection Details.....	99
6.2. NCHRP Full-Depth Precast Deck System.....	99
6.2.1. Load Calculations	99
6.2.2. Deck Design.....	104
6.2.3. Deck Overhang Design	106
6.3. Exodermic Precast Deck System	108
6.3.1. Load Calculations	108
6.3.2. Deck Design.....	109
6.3.3. Deck Overhang Design	111
6.4. Exodermic Cast-in-Place Deck System	111
6.4.1. Load Calculations	111
6.4.2. Deck Design.....	112
6.4.3. Deck Overhang Design	113
6.5. Steel Grid Partial-depth Cast-in-Place Deck System.....	114
6.5.1. Load Calculations	114
6.5.2. Deck Design.....	114

6.5.3. Deck Overhang Design	116
6.6. Barrier Rails.....	117
7. Design Adequacy of the Four Superstructure Systems.....	118
7.1. General.....	118
7.2. Load Calculations	118
7.3. Performance of Deck-Girder Systems	123
7.4. Shear Stud Requirements.....	126
7.5. Comparison of the Four Deck-Girder Systems.....	128
8. Conclusions and Recommendations	130
8.1. General.....	130
8.2. Conclusions.....	130
8.3. Recommendations.....	133
References	136
Appendix A – Proposed Barrier Rail Adequacy Check	138
Appendix B – Proposal to AASHTO to Revise Fatigue Requirements for Concrete Filled Steel Grid Decks	150
Appendix C – Recommended Special Provisions to the Alabama Standard Specifications for the Rapid Deck Replacements on Sister I-59 Bridges at Collinsville, AL	153
Appendix D – Verification of SAP2000 Live Load Calculation Procedure	170

List of Tables

Table 3.1 Reinforcing Bar Details	17
Table 4.1 Summary of Barrier Rails	51
Table 6.1 Cast-in-Place Deck System Load Cases	84
Table 6.2 Precast Deck System Load Cases	85
Table 6.3 Equivalent Strips.....	93
Table 6.4 Multiple Presence Factor, m	93
Table 6.5 Dynamic Load Allowance, IM	94
Table 6.6 Load Combinations and Load Factors	96
Table 6.7 Load Factors for Permanent Loads, γ_p	97
Table 6.8 NCHRP Full-Depth Deck System Extreme Moment Values	104
Table 6.9 Exodermic Precast Deck System Extreme Moment Values	108
Table 6.10 Exodermic Cast-in-Place Deck System Extreme Moment Values	111
Table 6.11 Steel Grid Deck System Extreme Moment Values.....	114
Table 7.1 Load Summary for Interior Girders	119
Table 7.2 Load Summary for Exterior Girders	120
Table 7.3 Unit Weights of the Four Deck Systems	121
Table 7.4 Summary of Nominal Moment and Shear Resistances of Deck Systems	124
Table 7.5 Design Ratios for the Four Deck-Girder Systems	125
Table 7.6 Summary of Girder Deflections.....	126

Table 7.7 Minimum Number of Shear Stud Required.....	126
Table 7.8 Recommended Shear Stud Configuration.....	127
Table 7.9 Normalized Comparison of the Deck-Girder Systems	129

List of Figures

Figure 2.1 Isometric View of Exodermic Deck System	8
Figure 2.2 Isometric View of Steel Grid Deck System	9
Figure 2.3 Installation of NCHRP Full-Depth Deck System CD-1A	11
Figure 2.4 Transverse Connection Detail for NCHRP Full-Depth Deck System CD-1B12	
Figure 3.1 Horizontal Alignment Data for Test Bridges	14
Figure 3.2 Horizontal Alignment Variables.....	15
Figure 3.3 Typical Cross-Section of Existing Superstructure	16
Figure 3.4 Cover Plate Detail.....	16
Figure 3.5 Shear Studs on Typical Bridge Girder.....	16
Figure 3.6 Existing Decking Cross-Section.....	17
Figure 3.7 Plan View of Existing Bridges	17
Figure 3.8 Typical Section of Existing Rail.....	18
Figure 3.9 Side Elevation View of I-59 Bridges Over SR68 at Collinsville	19
Figure 3.10 I-59 (SBR) Bridge Over SR68 at Collinsville.....	19
Figure 3.11 Underside View of I-59 (SBR) Bridge Over SR68	20
Figure 3.12 Topside View of I-59 (NBR) Bridge Over SR68.....	20
Figure 3.13 Topside View of I-59 (SBR) Bridge Over SR68.....	21
Figure 4.1 Existing and Proposed Renovated Superstructures of I-59 Bridges at Collinsville, AL.....	23

Figure 4.2 Proposed Deck Rehabilitation and Construction Sequence	24
Figure 4.3 NCHRP Full-Depth Precast Deck System Final Design	25
Figure 4.4 Plan View of NCHRP Full-Depth Precast Deck System	26
Figure 4.5 Cross-Section Details for NCHRP Full-Depth Precast Deck System	27
Figure 4.6 NCHRP Full-Depth Deck System Girder Attachment Detail	28
Figure 4.7 NCHRP Full-Depth Deck System Staged Construction Joint Details	28
Figure 4.8 NCHRP Full-Depth Deck System Transverse Panel-to-Panel Connection Details	29
Figure 4.9 NCHRP Full-Depth Deck System Existing to New Deck Transition Detail .	30
Figure 4.10 NCHRP Full-Depth Deck System Expansion Joint Details	30
Figure 4.11 Exodermic Precast Deck System Final Design	31
Figure 4.12 Plan View of Exodermic Precast Deck System.....	32
Figure 4.13 Isometric View of Exodermic Precast Deck System.....	33
Figure 4.14 Exodermic Precast Deck System Panel Height Adjustment Details	33
Figure 4.15 Cross-Section Detail of Exodermic Precast Deck System	34
Figure 4.16 Exodermic Precast Deck System Girder Attachment Detail	34
Figure 4.17 Exodermic Precast Deck System Staged Construction Joint Details	34
Figure 4.18 Exodermic Precast Transverse Panel-to-Panel Connection Details	35
Figure 4.19 Exodermic Precast Deck System Expansion Joint Details.....	35
Figure 4.20 Exodermic Precast Deck System Existing to New Deck Transition Detail .	36
Figure 4.21 Exodermic Cast-in-Place Deck System Final Design	37

Figure 4.22	Plan View of Exodermic Cast-in-Place Deck System.....	37
Figure 4.23	Isometric View of Exodermic Cast-in-Place Deck System.....	38
Figure 4.24	Exodermic Cast-in-Place Deck System Panel Height Adjustment Detail....	38
Figure 4.25	Cross-Section Details for Exodermic Cast-in-Place Deck System	39
Figure 4.26	Exodermic Cast-in-Place Deck System Girder Attachment Detail.....	39
Figure 4.27	Exodermic Cast-in-Place Deck System Staged Construction Joint Details .	40
Figure 4.28	Exodermic Cast-in-Place Deck System Expansion Joint Details.....	40
Figure 4.29	Steel Grid Cast-in-Place Deck System Details.....	41
Figure 4.30	Main Rail Dimensions for Steel Grid Cast-in-Place Deck System	42
Figure 4.31	Plan View of Steel Grid Cast-in-Place Deck System.....	42
Figure 4.32	Isometric View of Steel Grid Cast-in-Place Deck System.....	43
Figure 4.33	Steel Grid Cast-in-Place Deck System Panel Height Adjustment Details ...	43
Figure 4.34	Cross-Section Details for Steel Grid Cast-in-Place Deck System.....	44
Figure 4.35	Steel Grid Cast-in-Place Deck System Girder Attachment Details.....	44
Figure 4.36	Steel Grid Cast-in-Place Deck System Staged Construction Joint Details ..	45
Figure 4.37	Steel Grid Cast-in-Place Deck System Expansion Joint Details	45
Figure 4.38	L.B. Foster Precast NJ-Shape (FHWA 1997)	47
Figure 4.39	D.S. Brown Precast Barrier Rail.....	47
Figure 4.40	ALDOT Standard Barrier Rail	48
Figure 4.41	Concrete New Jersey Safety Shape Bridge Rail (FHWA 1997)	48
Figure 4.42	32-in Vertical Concrete Parapet (FHWA 1997).....	49

Figure 4.43 Missouri 30-in New Jersey Concrete Barrier (FHWA 1997).....	49
Figure 4.44 F-Profile Bridge Railing (FHWA 1997).....	50
Figure 4.45 ALDOT Standard Barrier Rail Details	53
Figure 4.46 Barrier Connection Details for the Exodermic Cast-in-Place Deck System	53
Figure 4.47 Barrier Connection Details for the Steel Grid Cast-in-Place Deck System .	54
Figure 4.48 Barrier Connection Details for the Exodermic Precast Deck System	54
Figure 4.49 Barrier Connection Details for the NCHRP Full-Depth Precast Deck System	55
Figure 5.1 Plan View of Proposed Layout.....	57
Figure 5.2 Construction Sequence, Stage I - Task 1	59
Figure 5.3 Construction Sequence, Stage I - Task 2.....	59
Figure 5.4 Construction Sequence, Stage I - Task 3.....	60
Figure 5.5 Construction Sequence, Stage I - Task 4.....	60
Figure 5.6 Construction Sequence, Stage I - Task 5.....	61
Figure 5.7 Construction Sequence, Stage I - Task 6.....	61
Figure 5.8 Construction Sequence, Stage I - Task 7.....	62
Figure 5.9 Construction Sequence, Stage II - Task 1	64
Figure 5.10 Construction Sequence, Stage II - Tasks 2 & 3.....	64
Figure 5.11 Construction Sequence, Stage II - Task 4	65
Figure 5.12 Construction Sequence, Stage II - Task 5	65
Figure 5.13 Construction Sequence, Stage II - Task 6	66

Figure 5.14 Construction Sequence, Stage II - Task 7	66
Figure 5.15 Construction Sequence, Stage II - Task 8	67
Figure 5.16 Construction Sequence, Stage II - Task 9	67
Figure 5.17 Construction Sequence, Stage II - Task 10	68
Figure 5.18 Construction Sequence, Stage III - Task 1	69
Figure 5.19 Construction Sequence, Stage III - Tasks 2 & 3	70
Figure 5.20 Construction Sequence, Stage III - Task 4	70
Figure 5.21 Construction Sequence, Stage III - Task 5	71
Figure 5.22 Construction Sequence, Stage III - Task 6	71
Figure 5.23 Construction Sequence, Stage IV - Task 1	73
Figure 5.24 Construction Sequence, Stage IV - Tasks 2 & 3	74
Figure 5.25 Construction Sequence, Stage IV - Task 4	74
Figure 5.26 Construction Sequence, Stage IV - Task 5	75
Figure 5.27 Construction Sequence, Stage IV - Task 6	75
Figure 5.28 Construction Sequence, Stage IV - Task 7	76
Figure 5.29 Construction Sequence, Stage IV - Task 8	76
Figure 5.30 Construction Sequence, Stage IV - Tasks 9 & 10	77
Figure 5.31 Construction Sequence, Stage IV - Task 11	77
Figure 5.32 Construction Sequence, Stage IV - Task 12	78
Figure 5.33 Construction Sequence, Stage IV - Task 13	78
Figure 5.34 Construction Sequence, Stage IV - Task 14	79

Figure 5.35 Construction Sequence, Stage IV - Task 15	79
Figure 5.36 Construction Sequence, Stage IV - Task 16	80
Figure 6.1 Cast-in-Place Deck System Load Cases	86
Figure 6.2 Cast-in-Place Deck System Load Cases (Continued)	87
Figure 6.3 Precast Deck System Load Cases	88
Figure 6.4 Precast Deck System Load Cases (Continued)	89
Figure 6.5 Cast-in-Place Deck System Loading Regions	90
Figure 6.6 Precast Deck System Loading Regions	90
Figure 6.7 Wind on Design Vehicle	95
Figure 6.8 Live Load Moments for Final Load Case	101
Figure 6.9 Wind on Live Load for Final Load Case	101
Figure 6.10 Dead Load Moments for Final Load Case	102
Figure 6.11 Moments for Final Load Case	102
Figure 6.12 Moment Limit States for Final Load Case	103
Figure 6.13 Moment Envelope for Limit States	103
Figure 6.14 Critical Section Location of Barrier Rail for Vehicle Collision	107
Figure 6.15 Required Reinforcing Bar Dimensions	108

List of Abbreviations

AASHTO	American Association of State Highway and Transportation Officials
AL	The State of Alabama
ALDOT	Alabama Department of Transportation
BIN	Bridge Identification Number
CIP	Cast-in-Place
CT	Vehicular Collision Force
DC	Dead Load of Structural Components and Nonstructural Attachments
FHWA	Federal Highway Administration
IM	Vehicular Dynamic Load Allowance
LL	Vehicular Live Load
LRFD	Load and Resistance Factor Design
NCHRP	National Cooperative Highway Research Program
NBR	Northbound Roadway
NU	Nebraska University
PC	Precast
SBR	Southbound Roadway
WL	Wind on Live Load

1. Introduction

1.1. Motivation

Deck deterioration is one of the most common problems in bridges because the service life of bridge decks is much less than that of other bridge components. This is due to exposure to the environment, weather, and heavy truck loadings. Many bridges that have good substructures and superstructures have decks that need to be rehabilitated or replaced.

Some bridges carry high volumes of traffic making the deck rehabilitation or replacement a difficult task. The rehabilitation or replacement on these high volume bridges needs to be conducted with minimal impact on traffic. One way of doing this is to replace the decking in a rapid manner during off peak hours, as in over-night or weekend work periods.

The Alabama Department of Transportation (ALDOT) has over 3 miles of major interstate bridges (3 to 5 lanes wide) with approximately 600,000 ft² of deteriorated decking in need of replacement or rehabilitation in the Birmingham, AL area (Oliver v). Rehabilitation has only served as a temporary fix in the past and has not proved to be a reliable, long-term solution to fix the deteriorated decks. This along with the high volume of traffic on these major interstate bridges makes rapid deck replacement the most feasible option.

Sister bridges in Collinsville, AL will be used to test and determine the best rapid replacement option for the bridges in the Birmingham area. Developing rapid replacement schemes for these test bridges to determine a feasible solution for the

deteriorated decks in the Birmingham area is the primary focus and drive for this research.

1.2. Objective

The overall objective of this research was to develop effective and efficient design and construction procedures for four viable rapid bridge deck replacement systems which were identified by Auburn University researchers in an earlier phase of the investigation. These systems, which will be described in detail in Chapter 2, are:

1. Exodermic steel grid panels with cast-in-place (CIP) concrete topping
2. Standard steel grid panels with cast-in-place (CIP) concrete topping
3. Prefabricated deck panels made of Exodermic steel grids and precast concrete
4. NCHRP full-depth precast concrete deck panels

Each of these four deck systems are to be placed on two adjacent simple spans of sister bridges on I-59 over SR68 at Collinsville, AL. The design friendliness, construction friendliness, construction time, product and construction costs, structural performances, and projected long-term durability of each of the systems will be evaluated and compared. Conclusions from this study will be used to determine the most feasible option for replacement of the deteriorated decks in the Birmingham area.

The focus and objective of this research reported on herein is to develop construction sequence plans and demonstrate design procedures for the four rapid deck replacement systems identified above for use on the Collinsville, AL test bridges.

1.3. Scope & Approach

The four deck systems indicated in Section 1.2 were investigated in this research. Each of these deck systems is capable of rapidly replacing the existing deck. Construction sequences were developed for each of these four systems to understand the loads that the decking will be subjected to and to provide a strategy for the construction on the test bridges. Once these loads were determined, the design adequacy of each of the four systems was checked and design modifications were made as needed to accommodate these loadings. The final design of each of the deck systems were compared with each other and with the existing decking of the test bridges.

1.4. Work Plan

The work plan to accomplish the research objectives is outlined below:

1. Review the literature on each of the four deck systems to determine a base design and to acquire connection details.
2. Develop a proposed sequence of construction to understand how the loads will be carried by each deck system.
3. Select an appropriate barrier rail to be used for each of the bridges.
4. Determine the loads that will be carried by each deck system.
5. Modify/Check the design of each of the four deck systems to accommodate the loads determined in (4).
6. Check the behavior of each of the four systems.

1.5. Organization

The first part of this chapter provides an overview of the basis for conducting this research. The next part explains the objectives to be completed and how they are to be fulfilled. The last part of this chapter explains the limitations and scope of this thesis. Chapter 2 provides a description of the state of the bridges in need of deck replacement in the Birmingham area and investigates the deck systems to be considered as feasible options through their background and review of literature. Each of the systems is to be tested on sister bridges that are described in Chapter 3. Chapter 4 discusses the proposed modifications that will be implemented on each of the test bridges. Chapter 5 presents a proposed sequence of construction for each of the sister bridges. The design of each of the systems will need to be checked and modified as necessary to carry the loads specific to these test bridges. These checks and modifications are described in Chapter 6. The behavior of each of the deck systems under service loads is determined and checked in Chapter 7. Finally, Chapter 8 discusses conclusions, recommendations, and other remarks.

2. Background and Review of Literature

2.1. Background

Many highly traveled bridges in the Birmingham area have deteriorated decks that are in need of rehabilitation or replacement. The deteriorated decking on these bridges must be rehabilitated or replaced in a rapid manner to minimize interruption to the high volumes of traffic.

There are many causes for deck deterioration. According to Oliver, the primary causes in the state of Alabama are:

- Cracking due to early drying and thermal shrinkage
- Weathering from freeze-thaw, wet-dry, and hot-cold cycling
- Later cracking from impact and fatigue from truck traffic

Deteriorated decks can be rehabilitated or replaced. Common rehabilitation practices involve using a bonded deck overlay. ALDOT engineers and managers have had negative results with these overlays (Oliver 4). “Overlays will debond and present maintenance problems from the time of debonding until replacement” (Oliver 8). Thus, rehabilitation only serves as a temporary fix and is not a practical solution for decks that still have good superstructures (apart from the decking). The most feasible long-term solution is to replace the deteriorated decking.

There are many solutions available to rapidly replace the decking. To determine the most feasible options, several deck systems will be investigated and tested on two sister bridges located in Collinsville, AL. The Collinsville, AL sister bridges were chosen for this examination due to similarities to many of the interstate bridges in the Birmingham,

AL area. The deck systems to be tested on the sister bridges are identified and investigated in the literature review section that follows.

2.2. Literature Review

2.2.1. General

Four deck replacement systems were selected to be investigated for this research. These systems are all capable of achieving the primary goal of rapid replacement; however, each system has unique features and capabilities. These systems were selected based on previous research conducted by Russell S. Oliver and discussions with ALDOT officials. As indicated in the work plan, a review of the literature of each of these systems is essential in order to determine a base design and to acquire connection details. The literature review for each of these systems follows.

Two of the deck systems are cast-in-place (CIP) while the other two are precast (PC). One of the two cast-in-place systems is a standard steel grid deck with partial-depth concrete. The other cast-in-place system is called an Exodermic deck. This system is a steel grid made composite with a reinforced concrete slab. One of the two precast systems is an Exodermic precast system similar to the cast-in-place Exodermic system, except the concrete slab is cast prior to delivery to the construction site. The last of the precast systems is a full-depth reinforced concrete system. This system is referred to in the National Cooperative Highway Research Program (NCHRP) Report 584 and is a modified version of the NU deck system designed by Nebraska University. This system will be referred to as the NCHRP full-depth deck system. The cast-in-place deck systems are to be installed over a weekend work period to allow for curing of the concrete slab

while the precast deck systems have potential to be installed during overnight work periods. This overnight installation is made possible by the use of rapid curing closure pours.

2.2.2. Exodermic Cast-in-Place Deck System

As previously mentioned, the Exodermic deck system consists of a steel grid deck made composite with a reinforced concrete slab. An isometric view of the Exodermic deck system is shown in Figure 2.1.

Exodermic deck systems have several advantages when compared to conventional reinforced concrete decks. This deck system is much lighter which allows it to achieve higher live load ratings. This reduction in weight does not sacrifice the strength, stiffness, ride quality, or expected life of the system. Long-term service life can be expected because the only welds used to assemble the grid are located near the neutral axis of the composite section. This minimizes the stress at the welds providing better fatigue resistance. Similarly, the distribution bar punch-out slots are also located near the neutral axis providing a fatigue resistance that rarely controls design. Hot dip galvanization of the grids will provide a strong resistance to corrosion, 50 plus years of protection. Using epoxy coated or galvanized reinforcing bars can achieve further corrosion protection. Above all of the advantages already listed, the major advantage to the interest of this report is the possibility of rapid construction. (Exodermic Bridge Deck, Inc.)

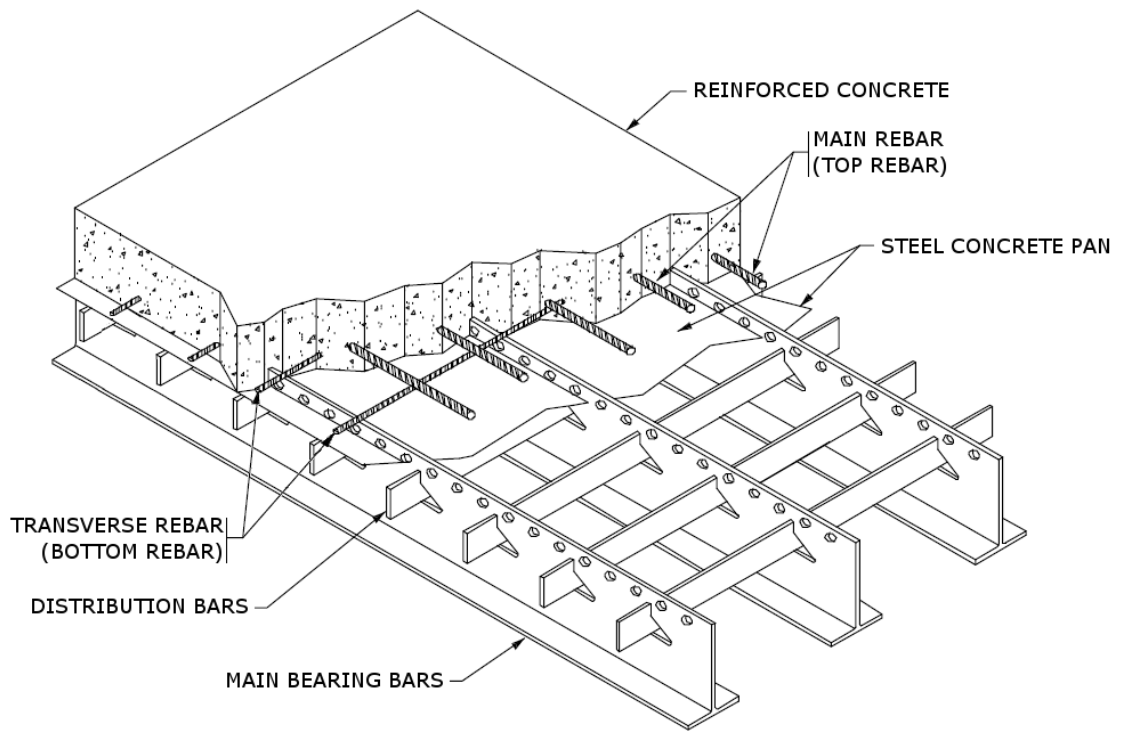

Figure 2.1 Isometric View of Exodermic Deck System

2.2.3. Steel Grid Partial-Depth Cast-in-Place Deck System

There are three different types of steel grid deck systems; open grid, full depth, and partial-depth. Open grid systems are the lightest and have the fastest and cheapest installation. However, they have poor ride quality and are not very strong or durable. Open grid systems are typically used on moveable bridges due to their light weight. Full depth systems are the heaviest of the three, but are very durable. This is a good choice when a reduction in dead load is not a main concern. The partial-depth system is somewhere between the open grid system and the full depth system. The partial-depth system was chosen for this investigation primarily to take advantage of its lightweight. An isometric view of a partial-depth system is shown in Figure 2.2.

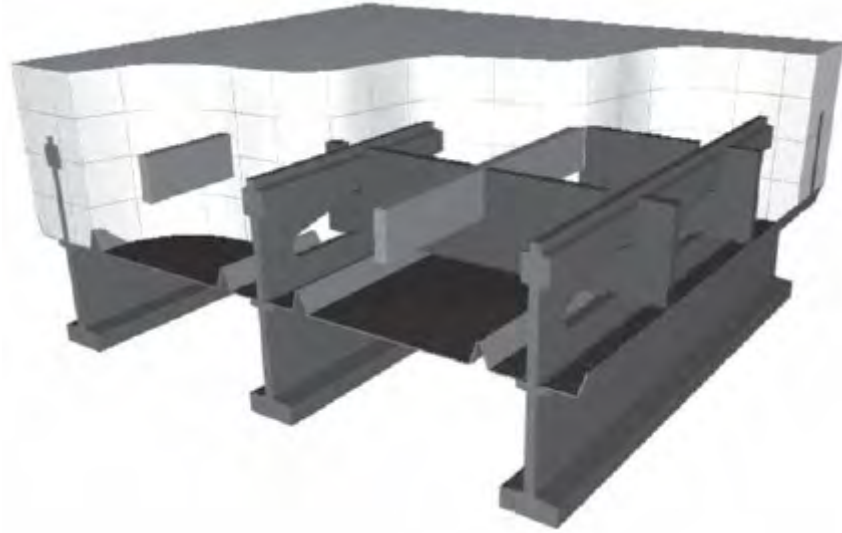

Figure 2.2 Isometric View of Steel Grid Deck System

2.2.4. Exodermic Precast Deck System

The Exodermic precast deck system has the same features and advantages as the Exodermic cast-in-place deck system. The primary difference between the systems is the connection details.

2.2.5. NCHRP Full-Depth Precast Deck System

The purpose of NCHRP Report 584 was to develop full-depth precast deck systems that would address issues that have put a strain on construction time with other full depth precast systems. To decrease construction time, the NCHRP full-depth deck systems were designed without post tensioning or the use of an overlay. Overlays can take several hours to cure before lanes can be open to traffic. To provide for a suitable ride quality without the use of an overlay, the NCHRP full-depth deck systems are designed with a quarter inch sacrificial layer that is to be used for texturing. This sacrificial layer has been neglected from all resistance calculations.

NCHRP Report 584 developed two decking systems, CD-1 and CD-2. System CD-2 has not been tested and was not considered for this investigation. CD-1 has two different sub systems, CD-1A and CD-1B. These two systems differ in the way that the panels are connected together along the transverse joint. System CD-1A was the first design, but required the panels to be installed at an angle to avoid interference with shear studs. This greatly complicated the installation process. A demonstration of this process is shown in Figure 2.3. System CD-1B was developed to avoid this complicated installation. System CD-1B uses a lap splice to achieve continuity between panels. This system will require a larger closure pour and much more care will need to be given to surfacing, but this system is a much better choice for ease and quickness of installation. Figure 2.4 shows the transverse panel-to-panel connection detail for system CD-1B. Since system CD-1B will have a much easier and quicker installation compared to system CD-1A, system CD-1B has been chosen for this investigation.

The NCHRP full-depth deck system was developed using a model that would be adequate for the majority of bridges in the states. A couple of design decisions make the NCHRP full-depth deck system conservative for our application. First of all, the NCHRP full-depth deck system was developed for 12-ft girder spacing, but the test bridge girders are spaced at 8-ft. The NCHRP full-depth deck system was also designed to withstand the weight of a 2-inch overlay should one be needed in the future. The NCHRP full-depth deck system could be refined for our application on account of the conservative design decisions. However, it was chosen to use the original design.

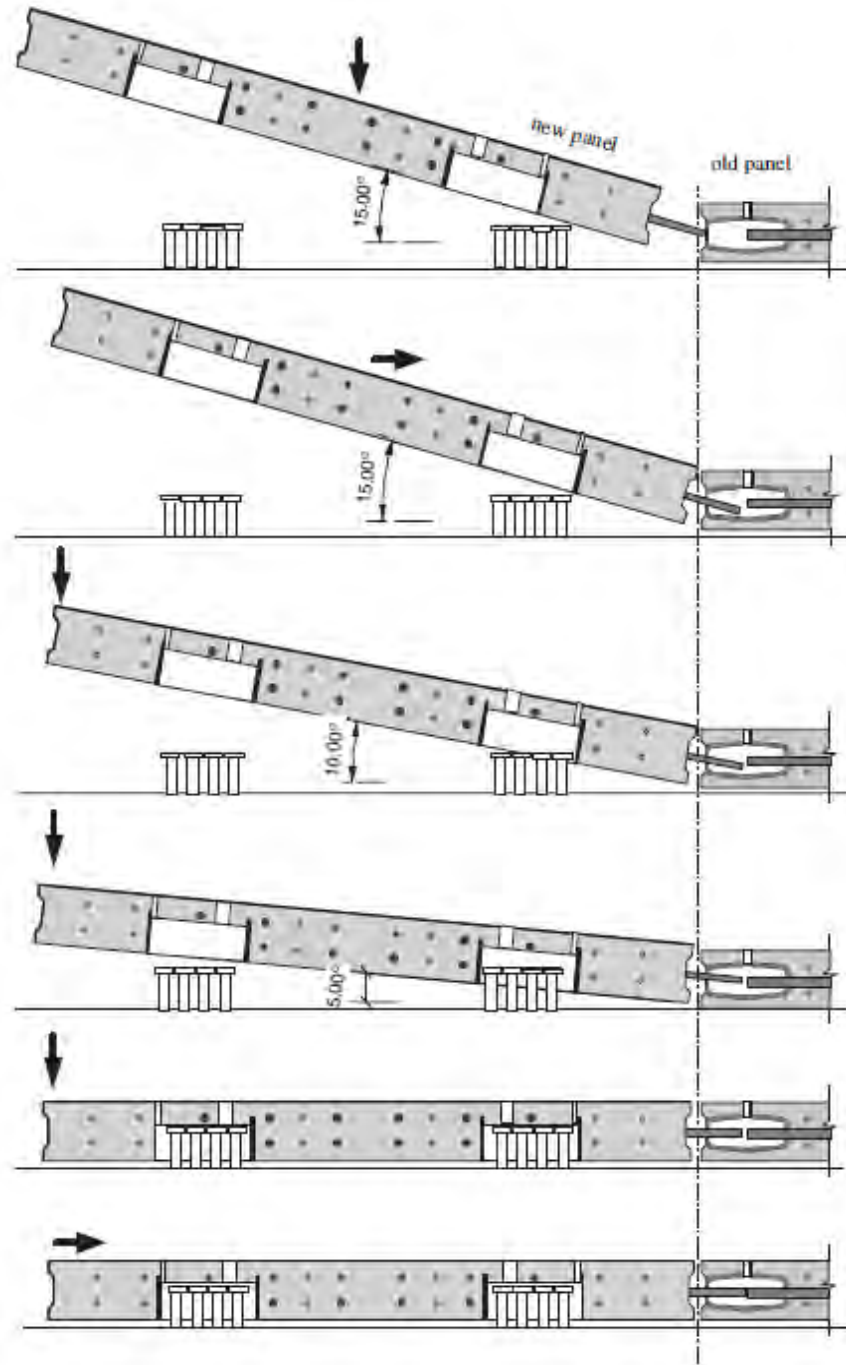

Figure 2.3 Installation of NCHRP Full-Depth Deck System CD-1A

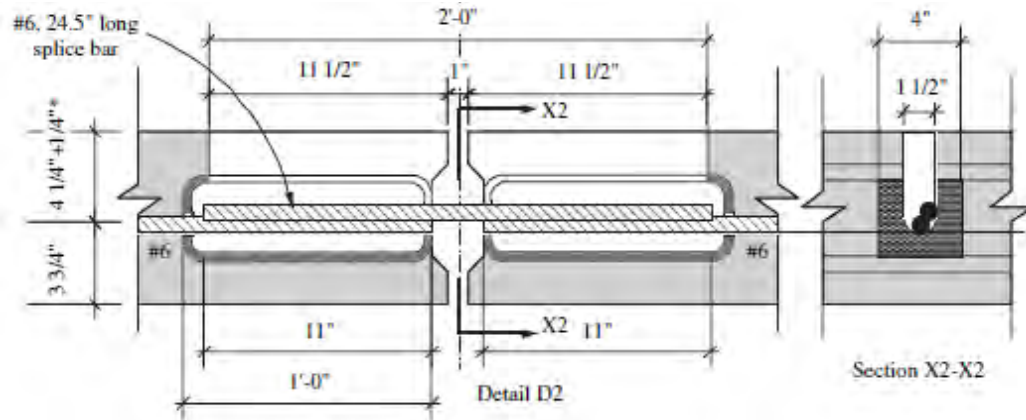

Figure 2.4 Transverse Connection Detail for NCHRP Full-Depth Deck System CD-1B

2.2.6. Barrier Rails

Several barrier rails were investigated for use on the sister test bridges. A detail for each barrier rail as well as a comparison of each of them is presented in Section 4.3 of this report.

3. Description of the Collinsville Bridges

3.1. General

Identifying a test bridge for the rapid deck replacement work proved much more difficult than anticipated. After considerable searching and discussions with ALDOT personnel, sister bridges on I-59 over SR68 at Collinsville, AL had been selected with the deck replacement work scheduled for FY2011. Collinsville is located approximately 20 miles northeast of Gadsden, AL. Pertinent information about the bridges is summarized below.

Bridge Location:	I-59 at Collinsville, AL (over SR 68)
BIN:	007536 (SBR) and 007537 (NBR)
Year Built:	1962
Design Load:	HS20-16
Number of Lanes:	2
Width:	28' curb-to-curb
Deck:	6" thick reinforced concrete (pea gravel concrete)
Support Girders:	Steel 36WF@150# (36-ksi yield strength) with Cover Plate
Girder Spacing:	8'-0"
Span Length(s):	4 simple spans (56'-10"/56'/56'/56'-10")
Shear Studs:	3/4" dia. X 4" Nelson studs

The I-59 sister bridges over SR68 at Collinsville, AL are steel girder bridges carrying interstate traffic. The bridges have girders acting compositely with the concrete deck. They are similar to most of the Birmingham, AL bridges that need rapid deck replacement, except the Birmingham bridges are much wider with somewhat longer span lengths.

The sister bridges are on a curve, but the curve is so small that it is considered negligible for the design of the decking. The deck panels will be designed and manufactured as rectangles but will be placed as skewed as necessary to handle the slight

curve. The cast-in-place portion of the decking will then shape and accommodate for the small curve. The horizontal alignment details for each of the bridges are shown in Figure 3.1. Figure 3.2 depicts what these variables are aside from SE, which is the super elevation of the bridges. P.I. is the station at the point of intersection of the two tangent lines. P.C. is the point of curvature and defines the beginning of the curve. P.T. is the point of tangency and defines the end of the curve. Δ is the central angle. D is the degree of curvature or central angle for a 100-ft arc. R is the radius of the curve. T is the tangent length from P.C. to P.I. or P.I. to P.T. L is the arc length of the curve, measured from P.C. to P.T. E is the external distance or offset from the P.I. to the middle of the curve.

HORIZONTAL CURVE DATA	
SOUTHBOUND LANE	NORTHBOUND LANE
P.I. STA. 1272+76.75	P.I. STA. 1272+34.85
$\Delta = 17^{\circ}22'00''$	$\Delta = 17^{\circ}48'20''$
D = 1'00'00"	D = 1'00'00"
R = 5729.58'	R = 5729.58'
T = 875.04'	T = 897.51'
L = 1736.67'	L = 1780.56'
E = 66.43'	E = 69.87'
SE = 0.028ft/ft	SE = 0.028ft/ft

Figure 3.1 Horizontal Alignment Data for Test Bridges

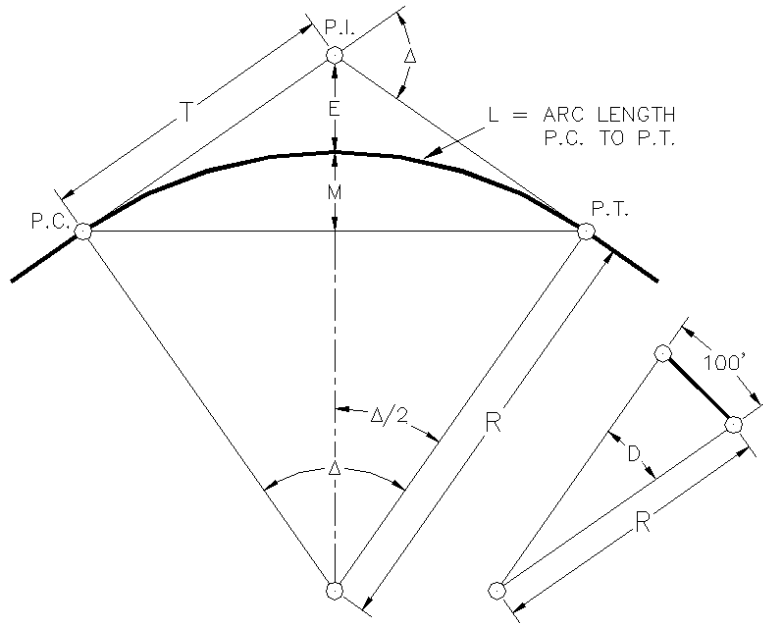

Figure 3.2 Horizontal Alignment Variables

Bridges consist of a superstructure and a substructure. The superstructure includes everything above the abutments and piers. This includes the bearings, girders, diaphragms, decking, and barriers. The substructure is everything below the superstructure. This includes the foundation, abutments, and bents. A typical cross-section of the existing superstructure is shown in Figure 3.3. Although they aren't shown in the figure, bearings transfer loads from the girders to the abutments and bents. The girders rest on top of the bearings. The existing girders have a yield strength of 36-ksi and are 36WF@150# steel sections. This section is similar to the modern W36x150. The girders have a 28-ft cover plate welded at mid-span. The cover plate detail is shown in Figure 3.4. The girders are connected by 15C@33.9# diaphragms. This section is similar to the modern C15x33.9. Diaphragms transmit lateral loads, provide bracing for lateral torsional buckling, and aid in gravity load distribution. They also provide stability during construction.

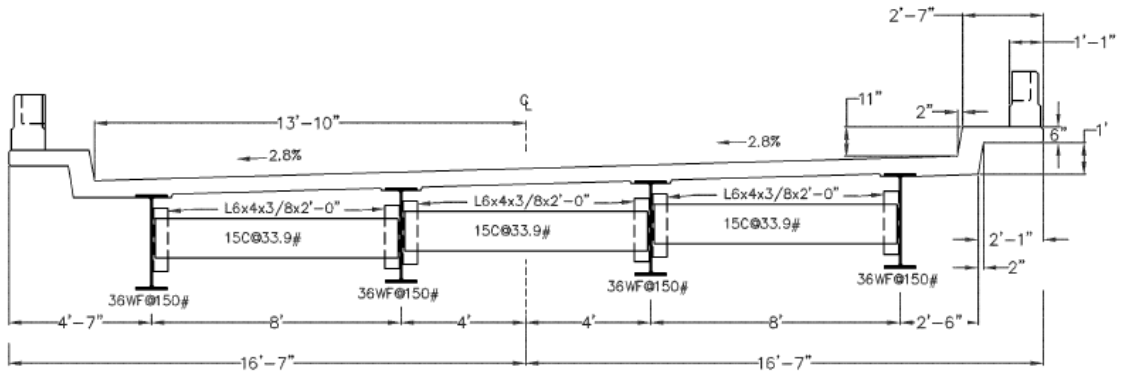

Figure 3.3 Typical Cross-Section of Existing Superstructure

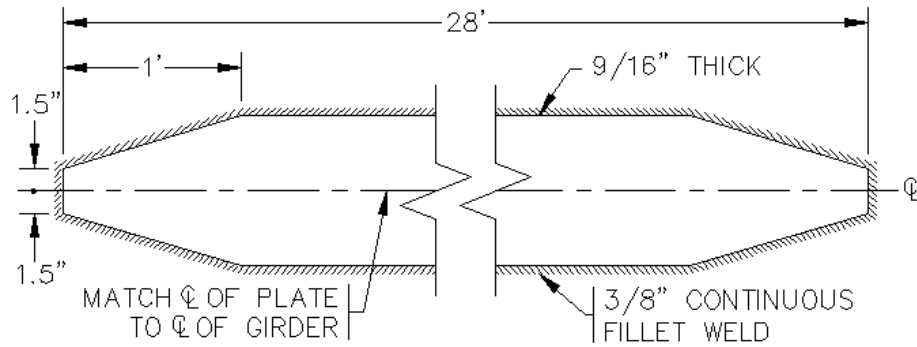

Figure 3.4 Cover Plate Detail

The bridge decking is the next component of the bridge superstructure. The bridge decking is made composite with the steel girders through $\frac{3}{4}$ " diameter x 4" Nelson shear studs as shown in Figure 3.5. 6.25-in thick reinforced concrete was used for the decking of the Collinsville bridges. A typical cross-section showing the reinforcing bars is shown in Figure 3.6. Reinforcing bar details for this cross-section are shown in Table 3.1.

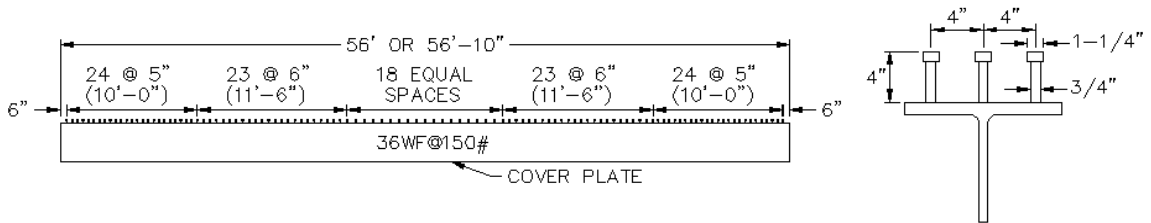

Figure 3.5 Shear Studs on Typical Bridge Girder

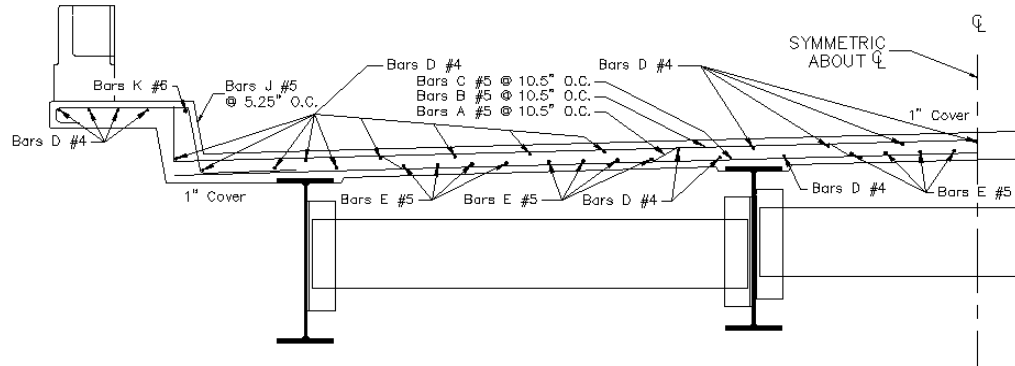

Figure 3.6 Existing Decking Cross-Section

Table 3.1 Reinforcing Bar Details

BAR	SIZE	END SPAN	INT. SPAN	SHAPE
		LENGTH	LENGTH	
A	#5	31'-5.75"	31'-5.75"	
B	#5	30'-8.75"	30'-8.75"	
C	#5	28'-8.00"	28'-8.00"	
D	#4	38'-2.75"	35'-9.50"	
E	#5	36'-4.25"	35'-11.00"	
J	#5	5'-10.50"	35'-11.00"	
K	#6	36'-5.25"	36'-0.00"	

A plan view of the bridges is shown in Figure 3.7. The primary importance of this figure is to show abutment, bent, and span numbers, deck drainage direction, and the general orientation of the bridges.

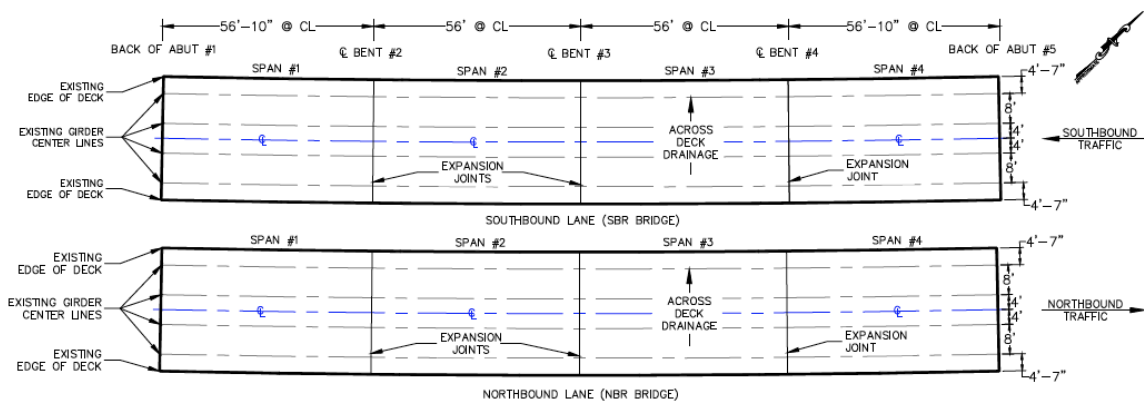

Figure 3.7 Plan View of Existing Bridges

The edge of the deck consists of a curb and a barrier rail as shown in Figure 3.6. A typical section of the existing barrier rail is shown in Figure 3.8. The test rating of the

existing rail is unknown and is unnecessary for this investigation. The average weight of the existing barrier rail was estimated at 118 pounds per linear foot.

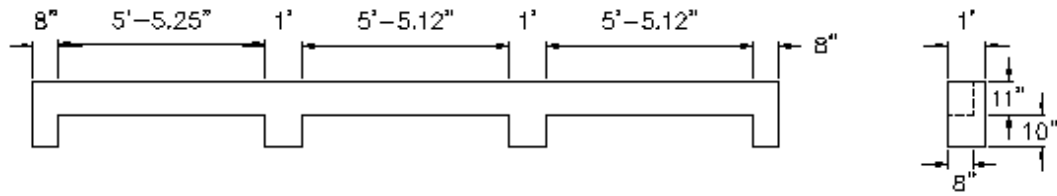

Figure 3.8 Typical Section of Existing Rail

3.2. Bridge Photos

Select photos of the northbound roadway (NBR) and southbound roadway (SBR) bridges are shown in Figures 3.9-3.13. As can be seen in Figures 3.9 and 3.10 only one of the spans of each bridge is over a roadway, and thus both bridges are very accessible from the underside. Figures 3.12 and 3.13 show that neither bridge has a shoulder and any deck replacement should probably include a deck/bridge widening to include a shoulder and Jersey barrier rails. Note in Figures 3.12 and 3.13 that both bridges have a slight horizontal curvature, but when viewed from the underside, it appears that the curvature is in the deck and rail and not in the girders.



Figure 3.9 Side Elevation View of I-59 Bridges Over SR68 at Collinsville



Figure 3.10 I-59 (SBR) Bridge Over SR68 at Collinsville

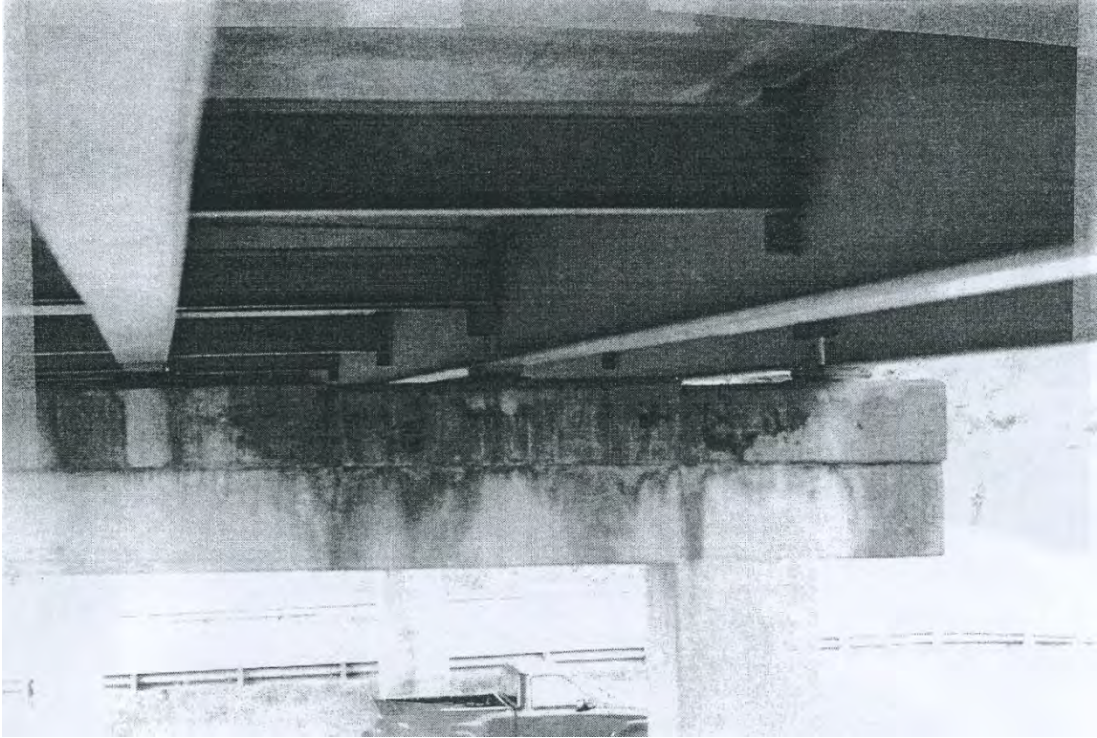

Figure 3.11 Underside View of I-59 (SBR) Bridge Over SR68

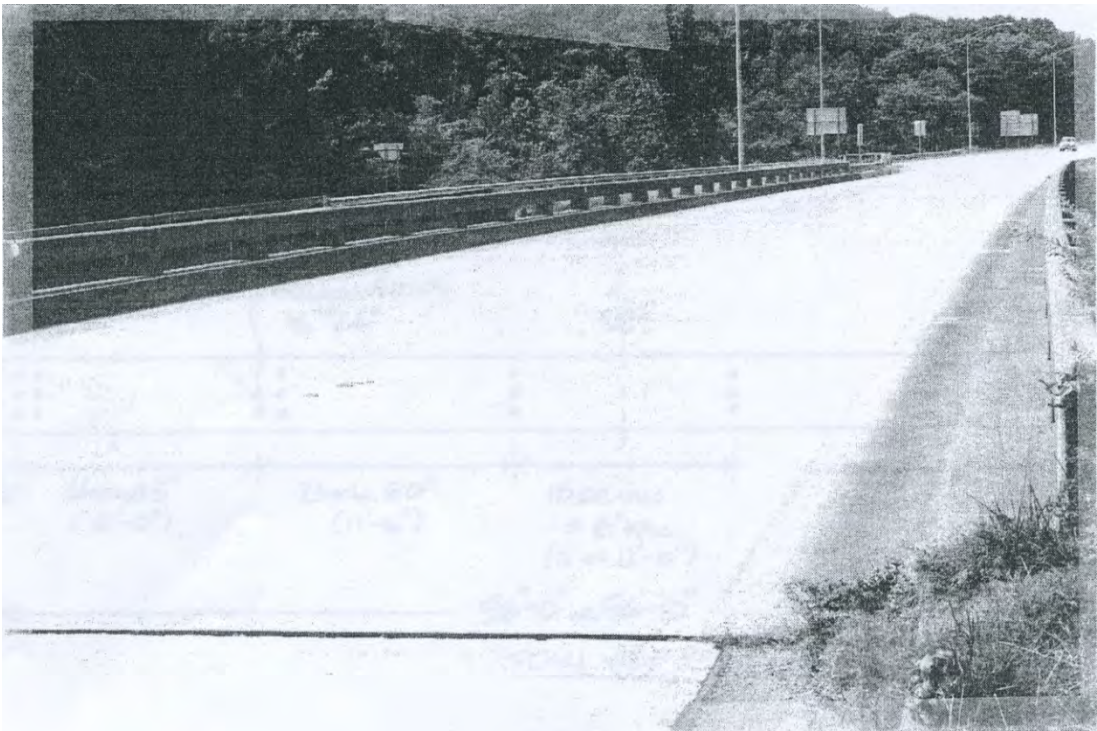

Figure 3.12 Topside View of I-59 (NBR) Bridge Over SR68

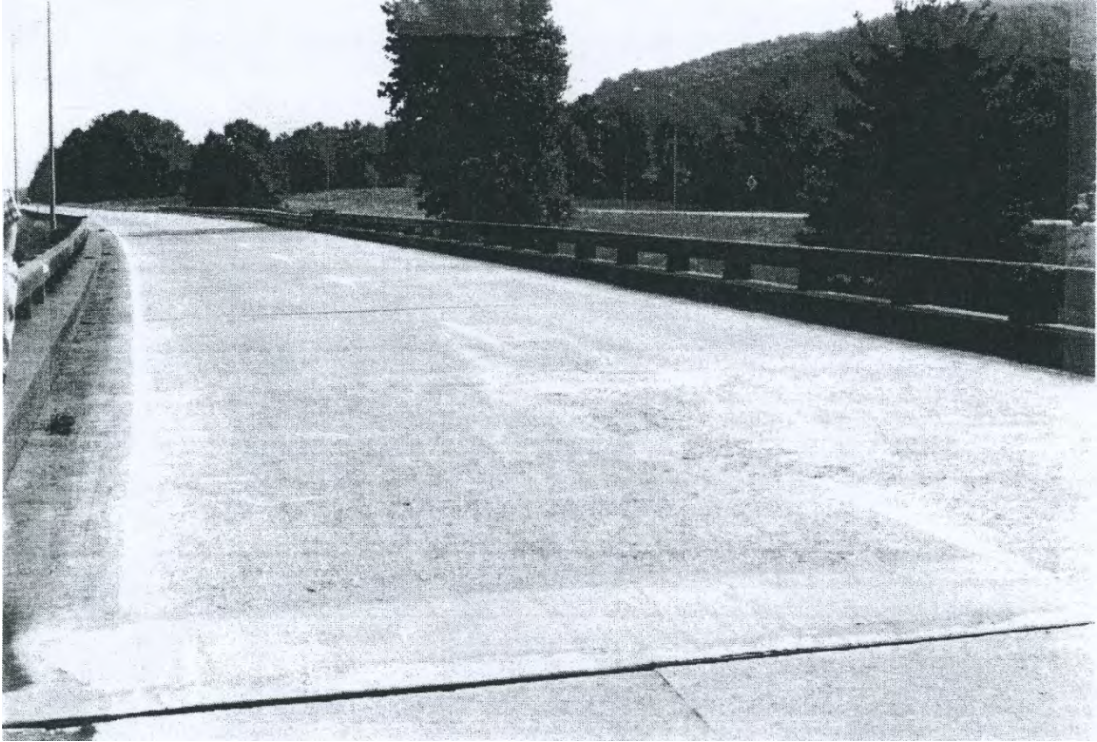

Figure 3.13 Topside View of I-59 (SBR) Bridge Over SR68

4. Description of Proposed Modifications

4.1. Bridge Widening

The existing Collinsville sister bridges are narrow (28' curb-to-curb) two lane bridges. In order to make the renovated sister bridges safer and to better replicate the condition of the Birmingham, AL bridges, ALDOT engineers and the Auburn researchers agreed that it would be better to widen the Collinsville bridges while in the rapid deck replacement process. For the bridges/decks to be widened and New Jersey barriers to be added, the abutments and support bents should be widened/prepared before beginning the deck replacement work. This work can be done without interference with I-59 or SR68 traffic. When this work is completed, the deck replacement work can begin and can be performed in two stages, wherein one lane of traffic is maintained at all times and the partially prefabricated deck panels are field spliced near the bridge centerline.

4.2. Proposed Deck Systems

The decking is to be rapidly replaced by installing the four deck systems discussed in Chapter 2. The two precast deck systems are to be installed on the Southbound Bridge in Stages III and IV while the two cast-in-place deck systems are to be installed on the Northbound Bridge in Stages I and II as shown in Figures 4.1 and 4.2. Details for each of the deck systems follow.

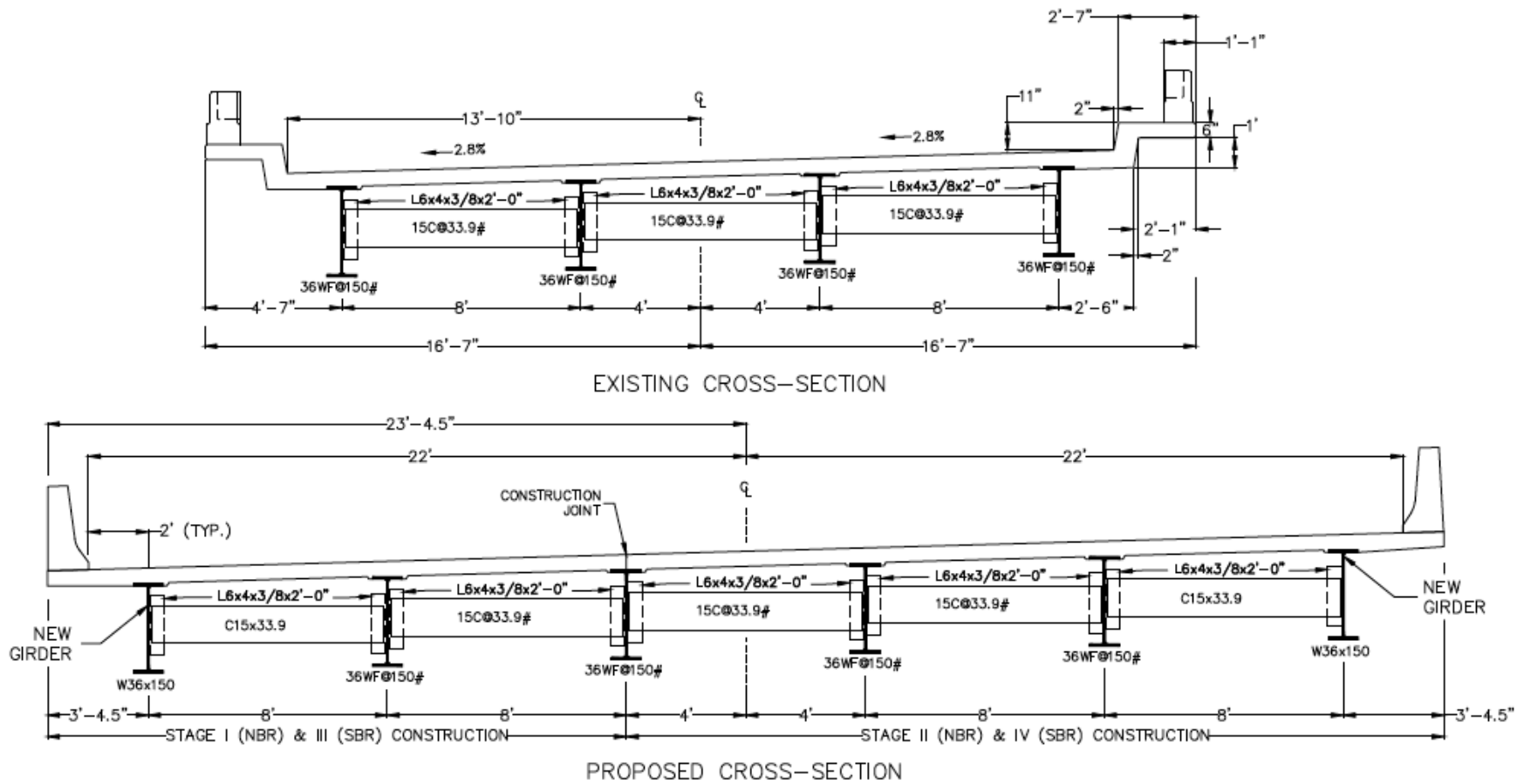

Figure 4.1 Existing and Proposed Renovated Superstructures of I-59 Bridges at Collinsville, AL

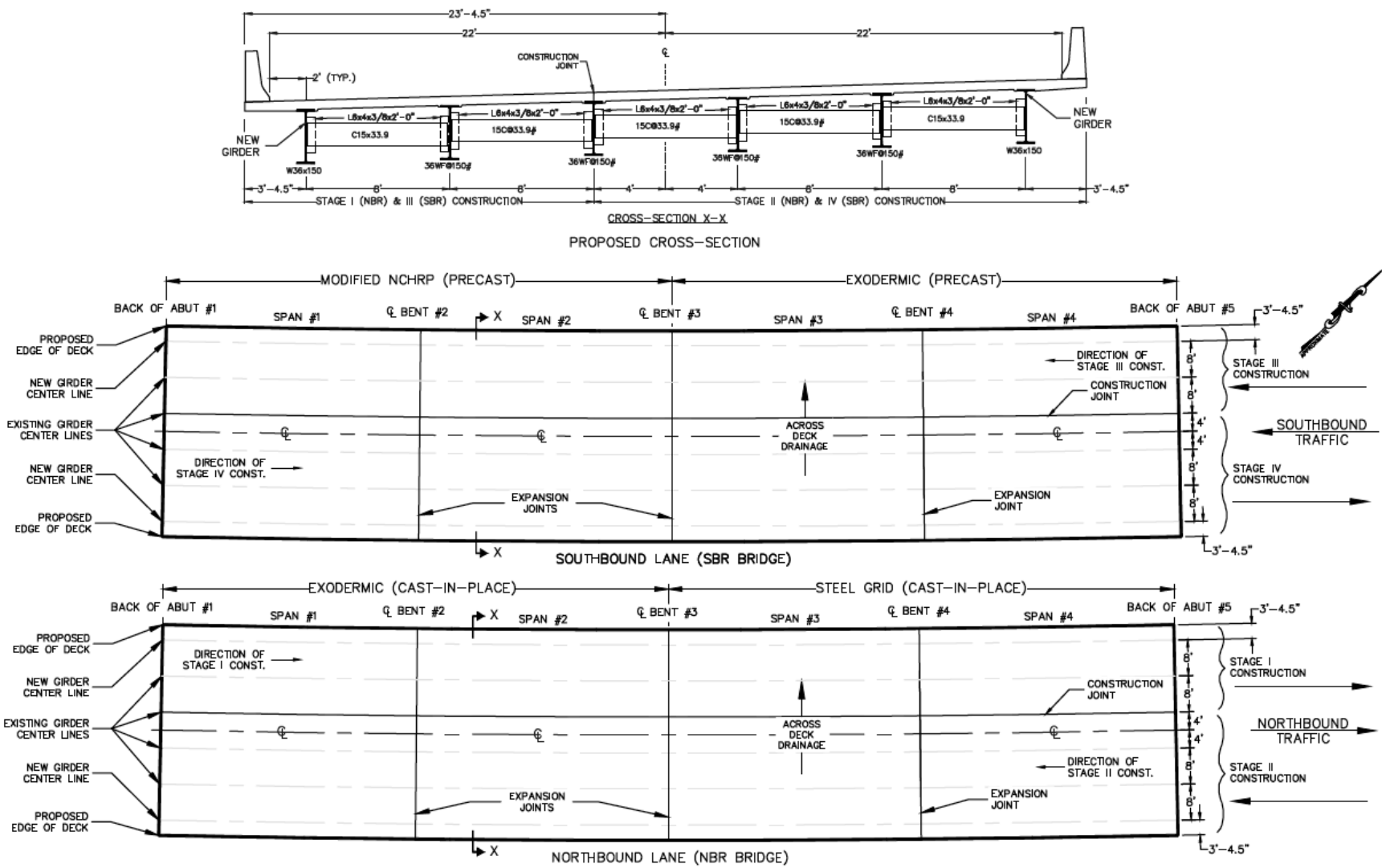

Figure 4.2 Proposed Deck Rehabilitation and Construction Sequence

4.2.1. NCHRP Full-Depth Precast Deck System

The NCHRP full-depth precast deck system is to be installed on Spans 1 & 2 of the Southbound Bridge as shown in Figure 4.2. System CD-1B from the NCHRP Report 584 was chosen as the design of the system due to reasons previously discussed in Chapter 2. An optional sacrificial layer of 1/4 inch is specified to allow for surface roughening or texturing. The final design of this deck system is shown in Figure 4.3. Further details, including conceptual construction details, are shown in Figures 4.4 through 4.10. Barrier rail details are discussed in Section 4.3.

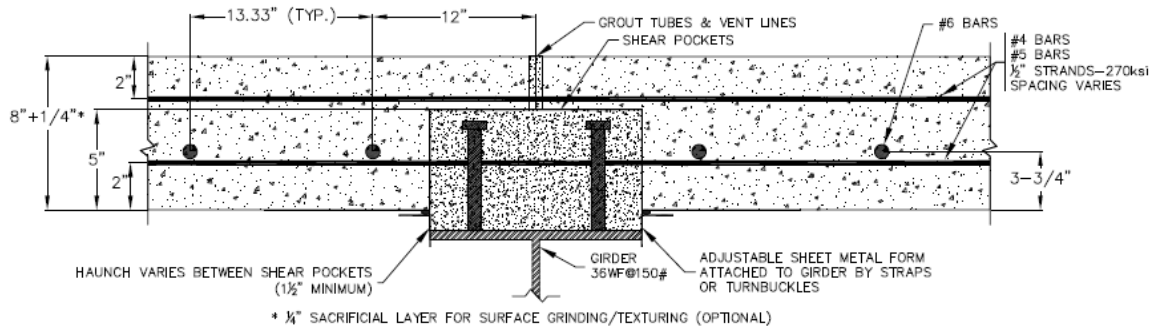

Figure 4.3 NCHRP Full-Depth Precast Deck System Final Design

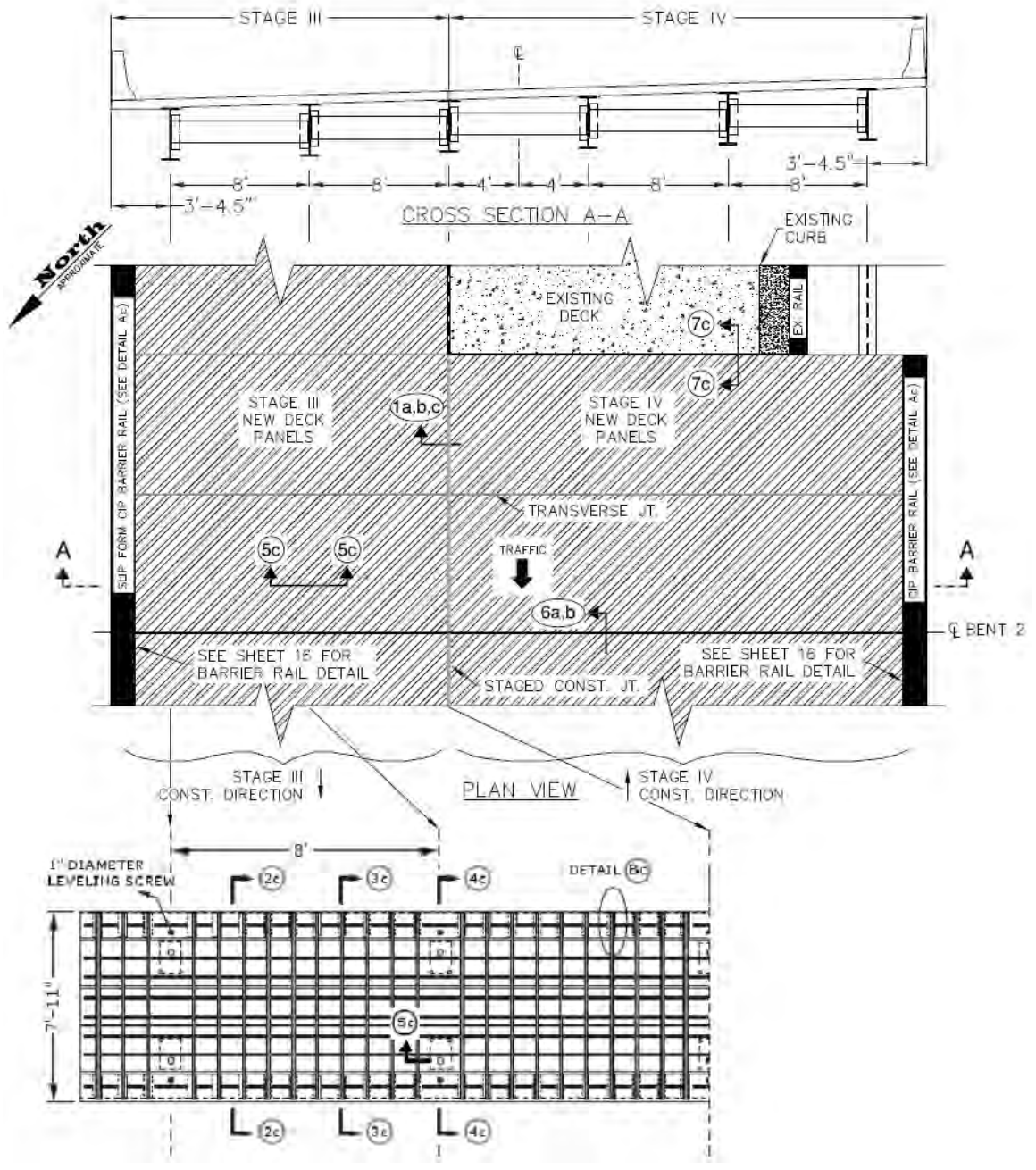

Figure 4.4 Plan View of NCHRP Full-Depth Precast Deck System

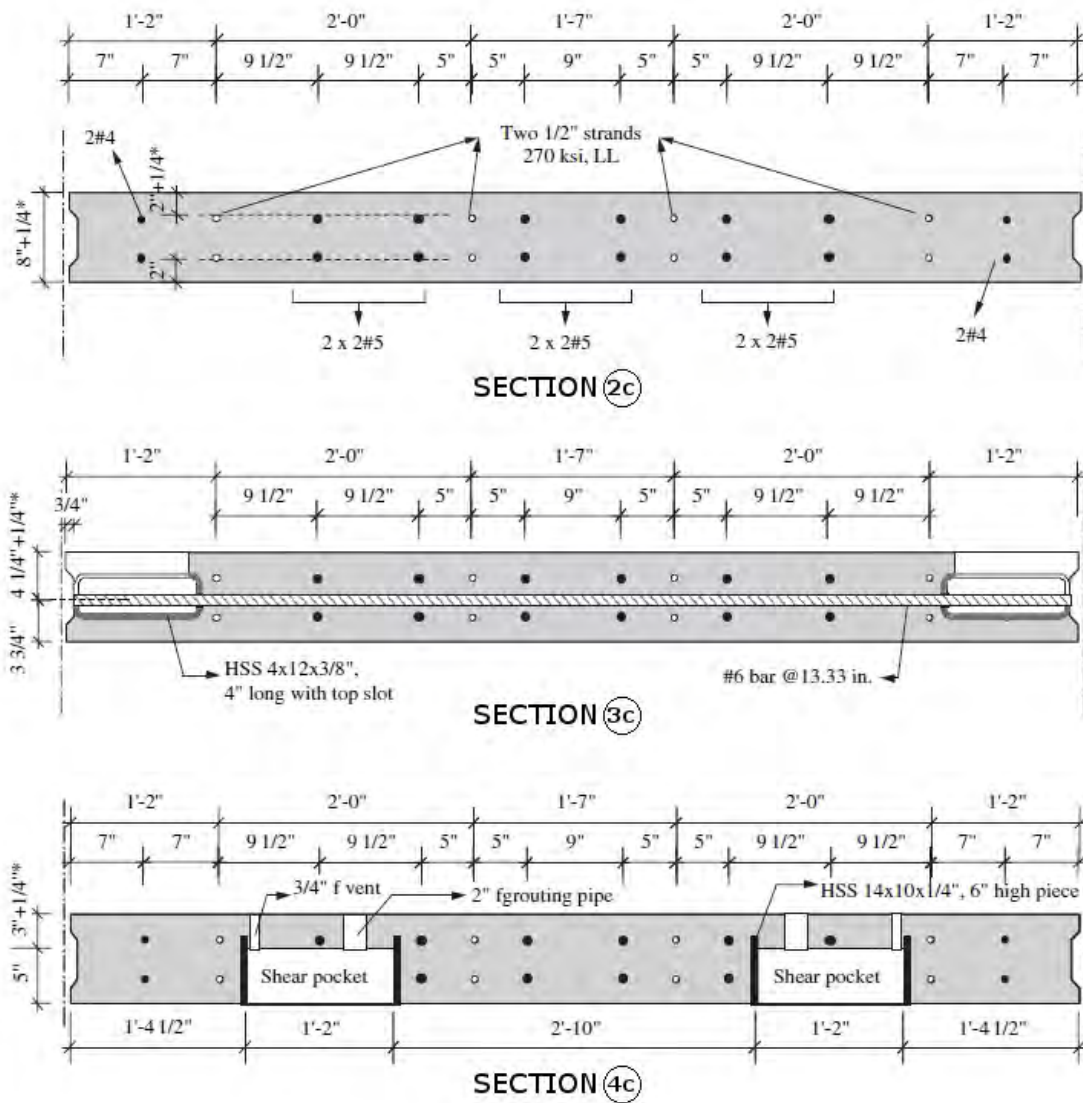
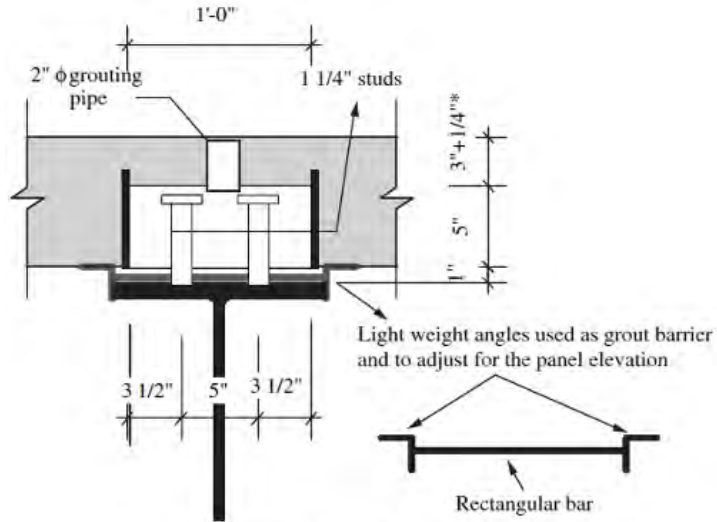

Figure 4.5 Cross-Section Details for NCHRP Full-Depth Precast Deck System



SECTION 5c

Figure 4.6 NCHRP Full-Depth Deck System Girder Attachment Detail

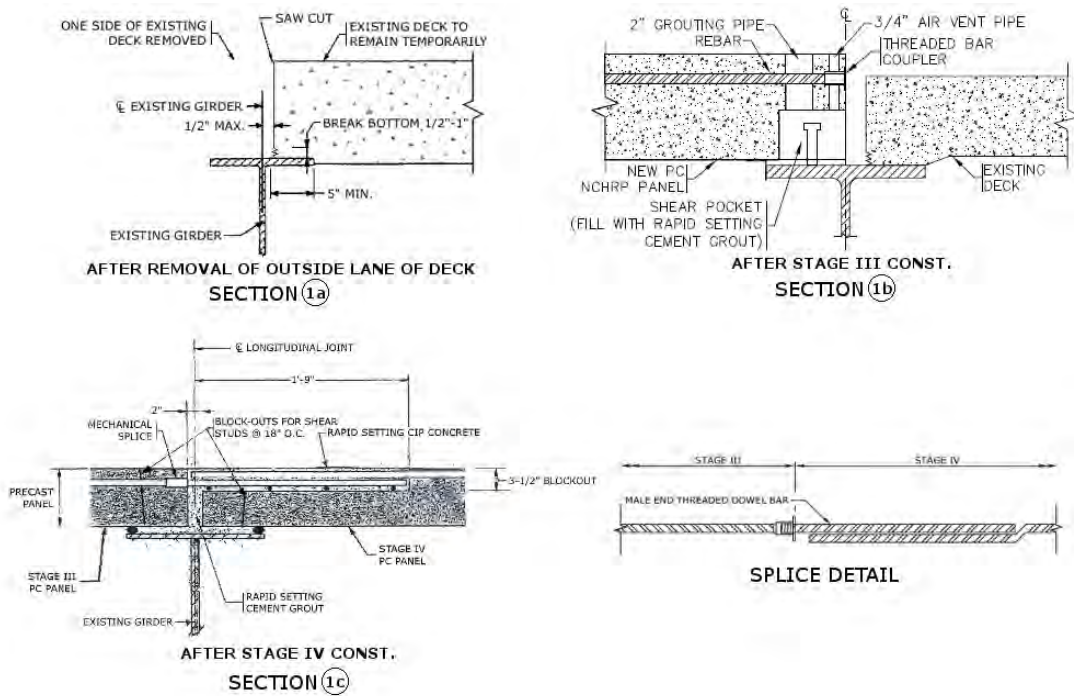
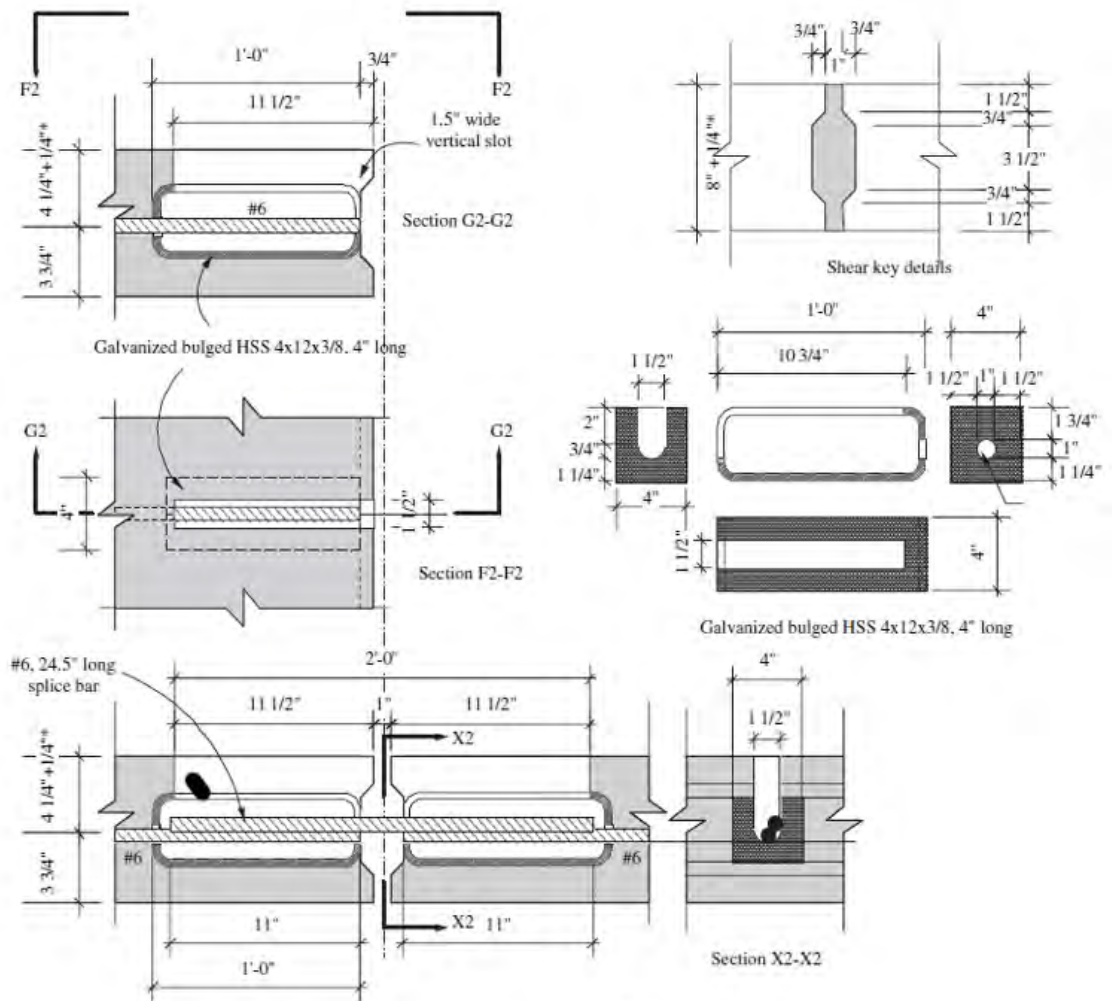

Figure 4.7 NCHRP Full-Depth Deck System Staged Construction Joint Details



DETAIL (Bc)

Figure 4.8 NCHRP Full-Depth Deck System Transverse Panel-to-Panel Connection Details

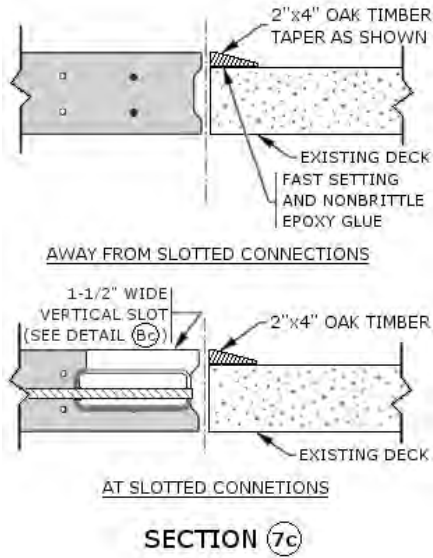

Figure 4.9 NCHRP Full-Depth Deck System Existing to New Deck Transition Detail

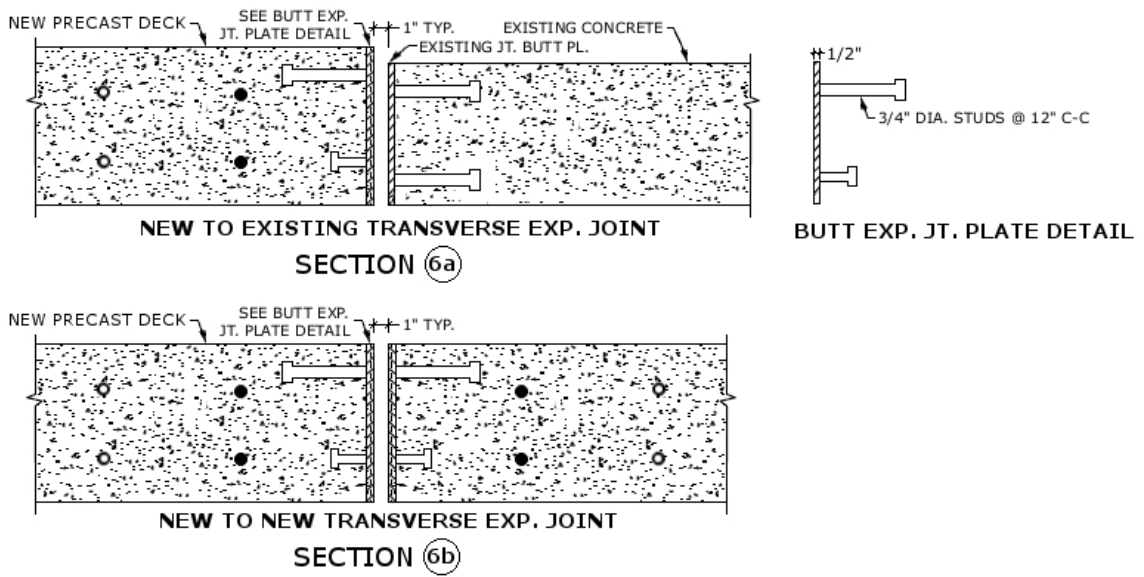

Figure 4.10 NCHRP Full-Depth Deck System Expansion Joint Details

4.2.2. Exodermic Precast Deck System

The Exodermic precast deck system is to be installed on Spans 3 & 4 of the Southbound Bridge as shown in Figure 4.2. A preliminary design was chosen from Exodermic design tables. A final design for this system was developed through design checks and other design considerations. The final system consists of WT5x6 main bars spaced at 10 inches center to center and #5 top reinforcing bars spaced at 5 inches. The concrete thickness of this system was adjusted to achieve an overall depth of 8 inches. This adjustment was made so that this system will be the same depth as the NCHRP full-depth deck system that is to be installed on the same bridge. This will allow for similar deck surface elevations without requiring an unreasonably large haunch. An optional ¼ inch sacrificial layer is also specified to provide for surface roughening or texturing. The final design of this deck system is shown in Figure 4.11. Further details, including conceptual connection details, are shown in Figure 4.12 through 4.20. Barrier rail details are discussed in Section 4.3.

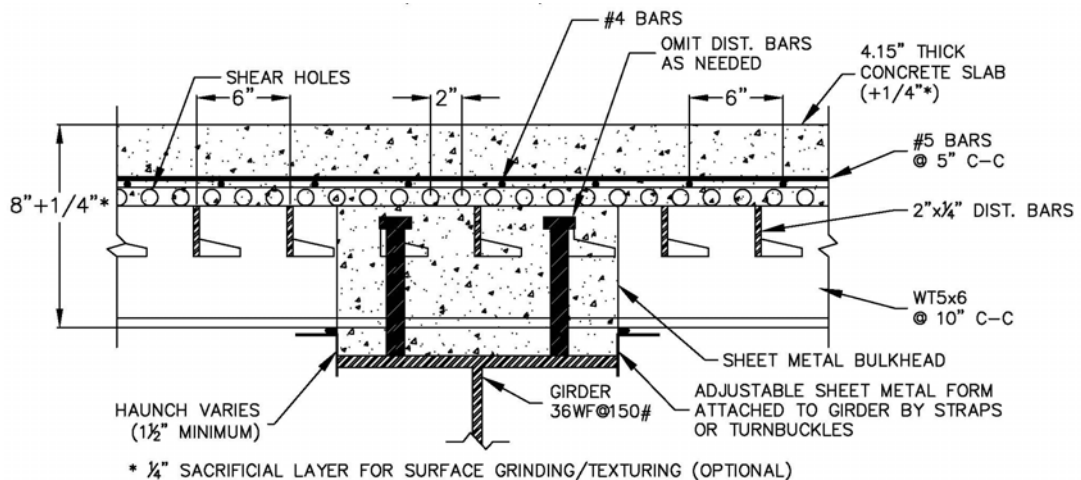

Figure 4.11 Exodermic Precast Deck System Final Design

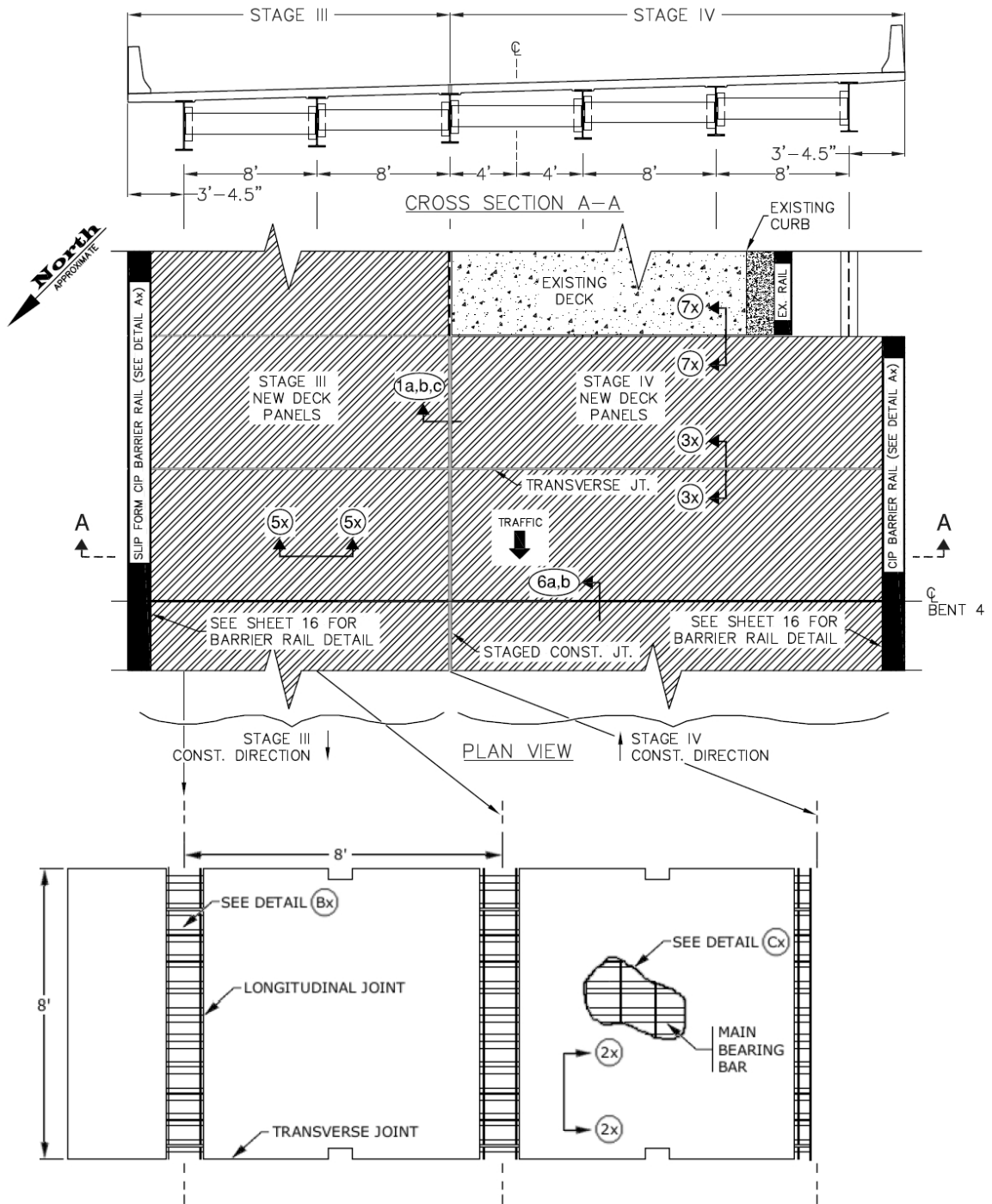

Figure 4.12 Plan View of Exodermic Precast Deck System

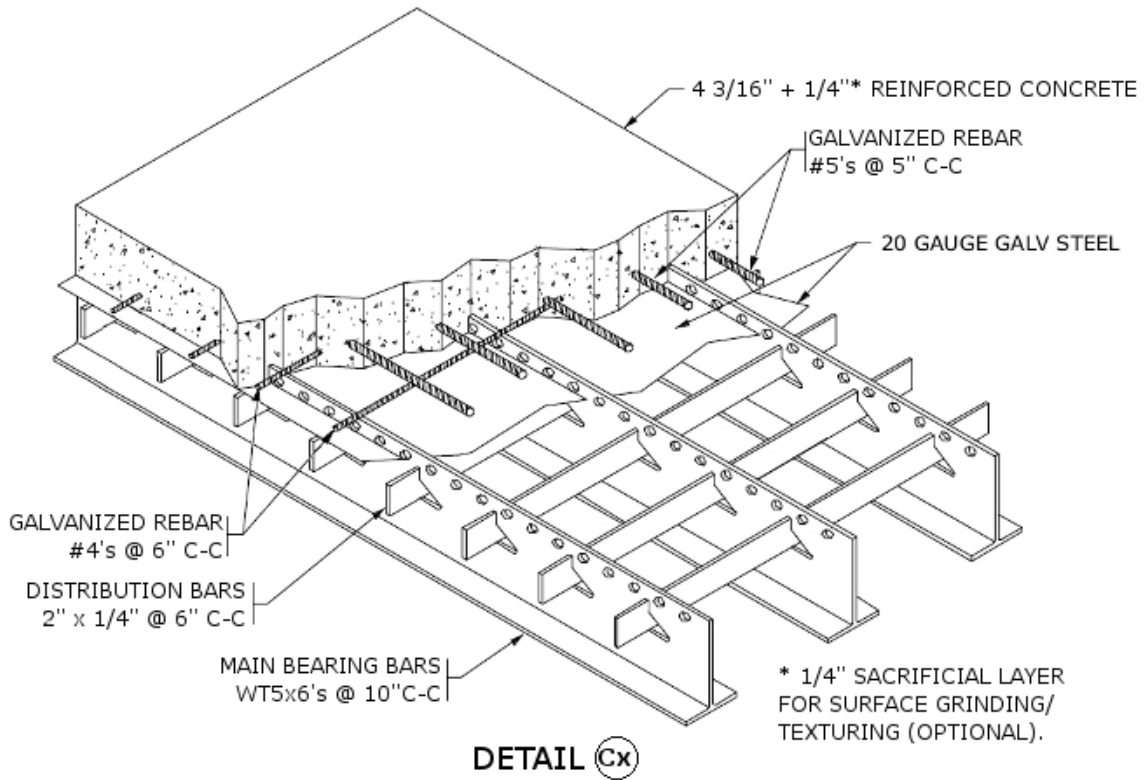

Figure 4.13 Isometric View of Exodermic Precast Deck System

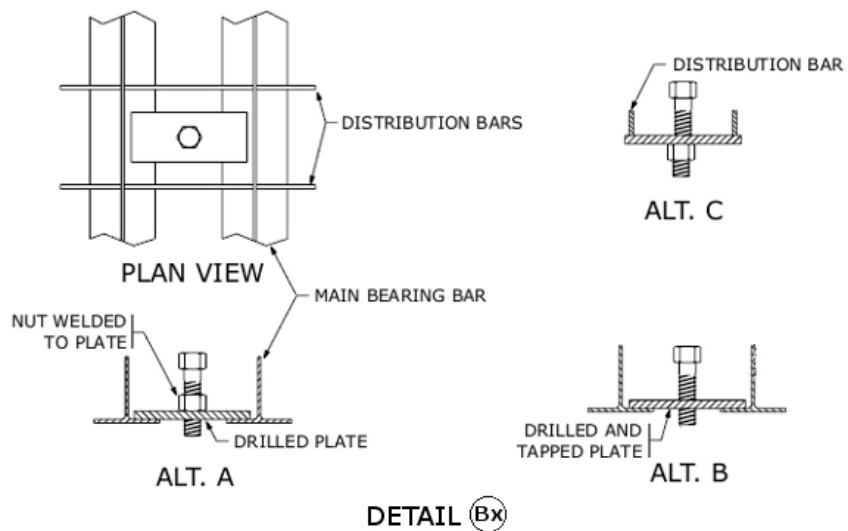

Figure 4.14 Exodermic Precast Deck System Panel Height Adjustment Details

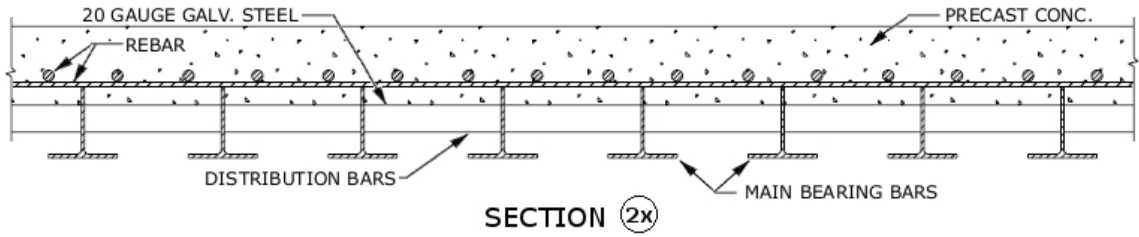

Figure 4.15 Cross-Section Detail of Exodermic Precast Deck System

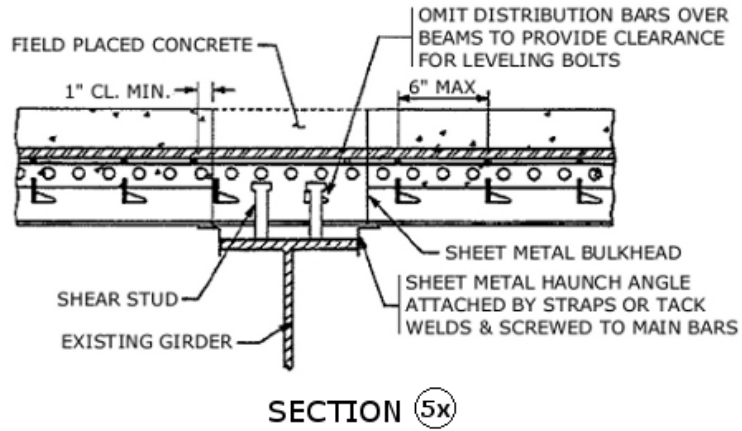

Figure 4.16 Exodermic Precast Deck System Girder Attachment Detail

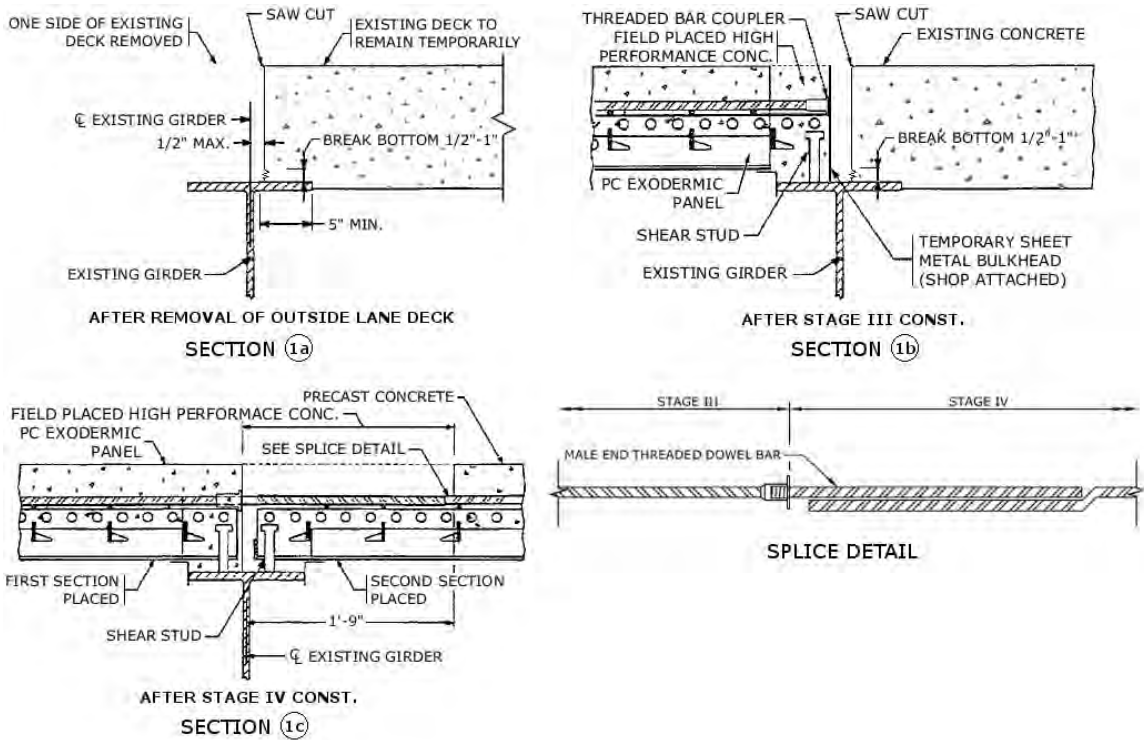
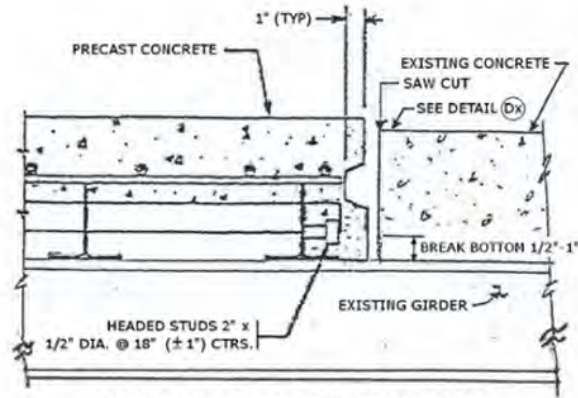
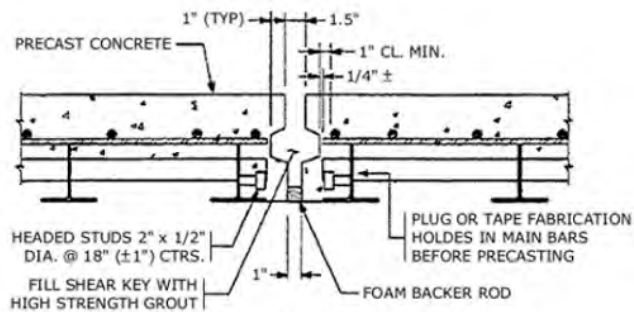

Figure 4.17 Exodermic Precast Deck System Staged Construction Joint Details



NEW TO EXISTING TRANSVERSE JOINT

SECTION 7x



NEW TO NEW TRANSVERSE JOINT

SECTION 3x

Figure 4.18 Exodermic Precast Transverse Panel-to-Panel Connection Details

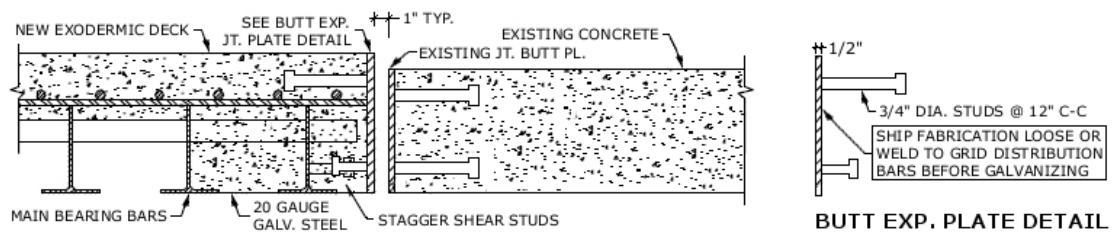

NEW TO EXISTING TRANSVERSE EXP. JOINT

SECTION 6a

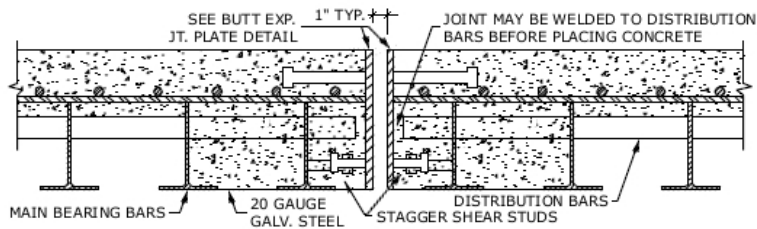

NEW TO NEW TRANSVERSE EXP. JOINT

SECTION 6b

Figure 4.19 Exodermic Precast Deck System Expansion Joint Details

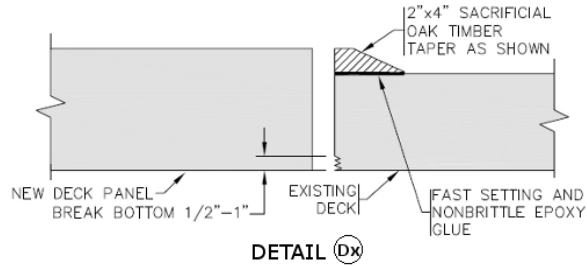

Figure 4.20 Exodermic Precast Deck System Existing to New Deck Transition Detail

4.2.3. Exodermic Cast-in-Place Deck System

The Exodermic cast-in-place deck system is to be installed on Spans 1 & 2 of the Northbound Bridge as shown in Figure 4.2. It was decided to use the same steel grid panel for the Exodermic CIP system as that of the Exodermic PC system. The two systems will have almost the same behavior. It was chosen to use the same design to simplify the manufacturing process and reduce the cost of the steel grids. The Exodermic Cast-in-Place system has a concrete slab that is cast in the field, which eliminates the need for a sacrificial layer. The lack of a sacrificial layer and the concrete being cast in the field and not precast are the only differences between this system and the Exodermic precast system. The final design of this deck system is shown in Figure 4.21. Further details, including the conceptual connection details, are shown in Figures 4.22 through 4.28. Barrier rail details are discussed in Section 4.3.

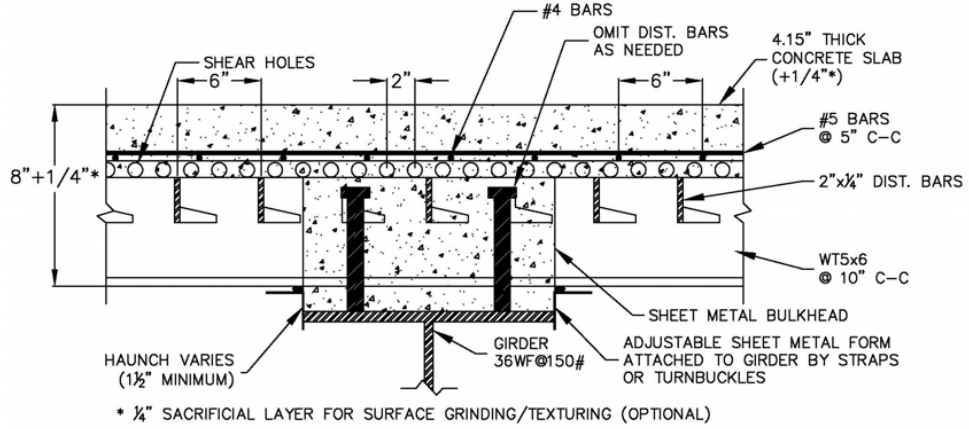

Figure 4.21 Exodermic Cast-in-Place Deck System Final Design

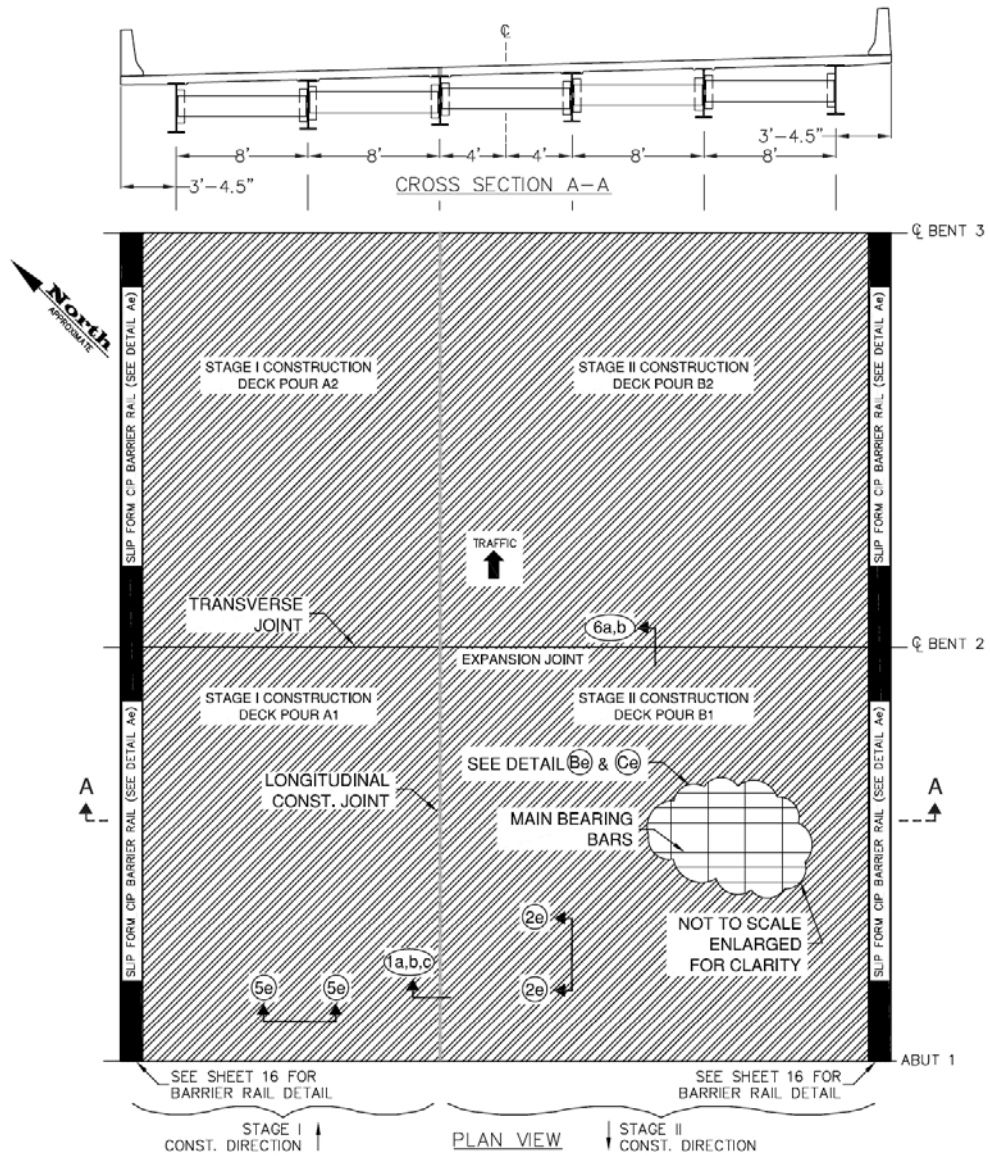

Figure 4.22 Plan View of Exodermic Cast-in-Place Deck System

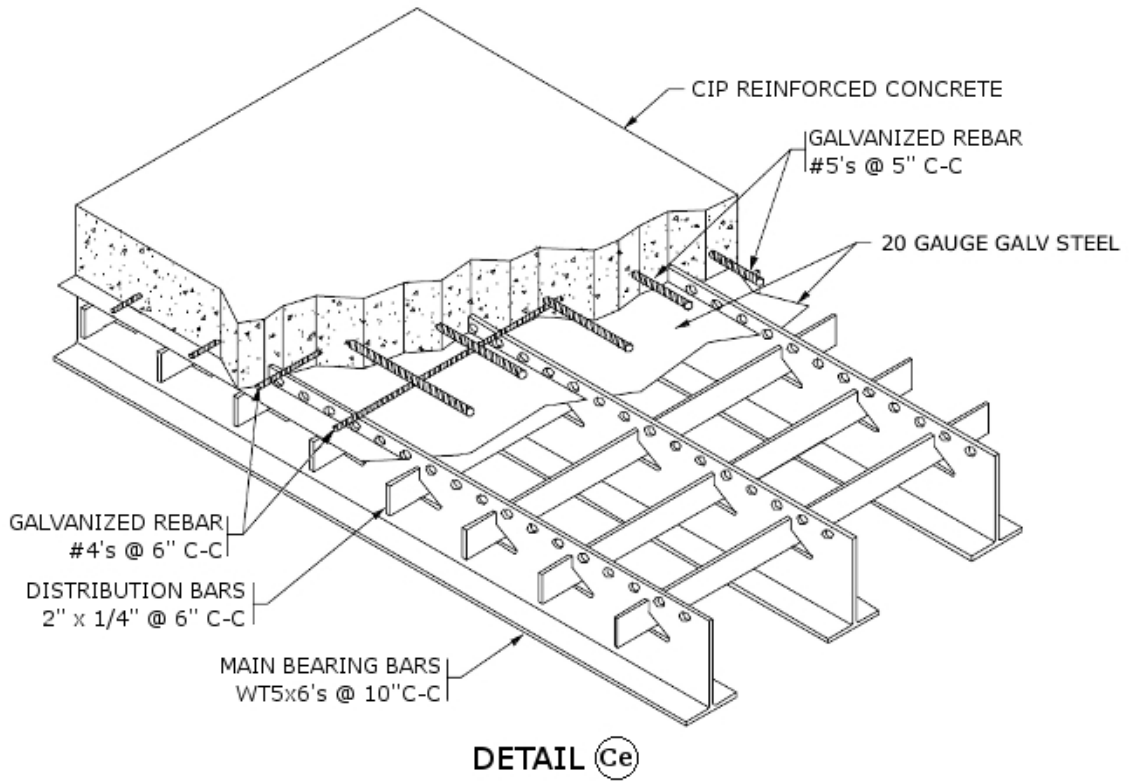

Figure 4.23 Isometric View of Exodermic Cast-in-Place Deck System

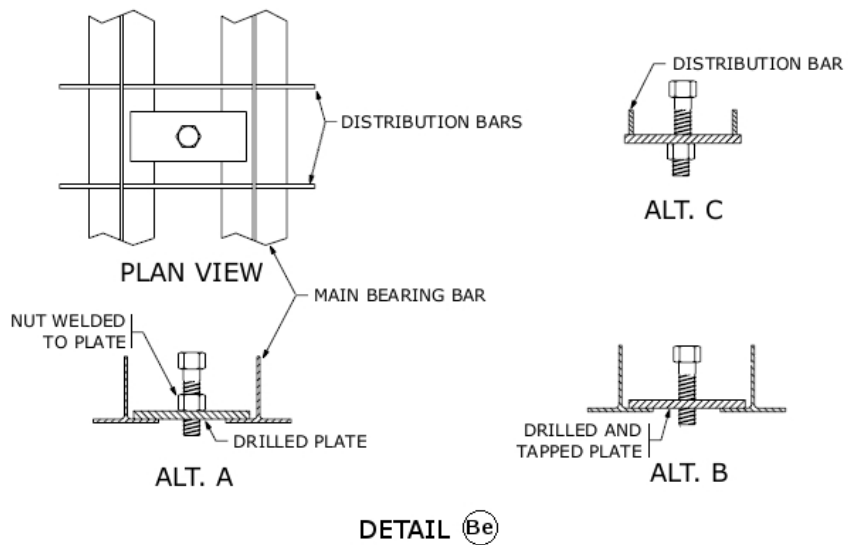

Figure 4.24 Exodermic Cast-in-Place Deck System Panel Height Adjustment Detail

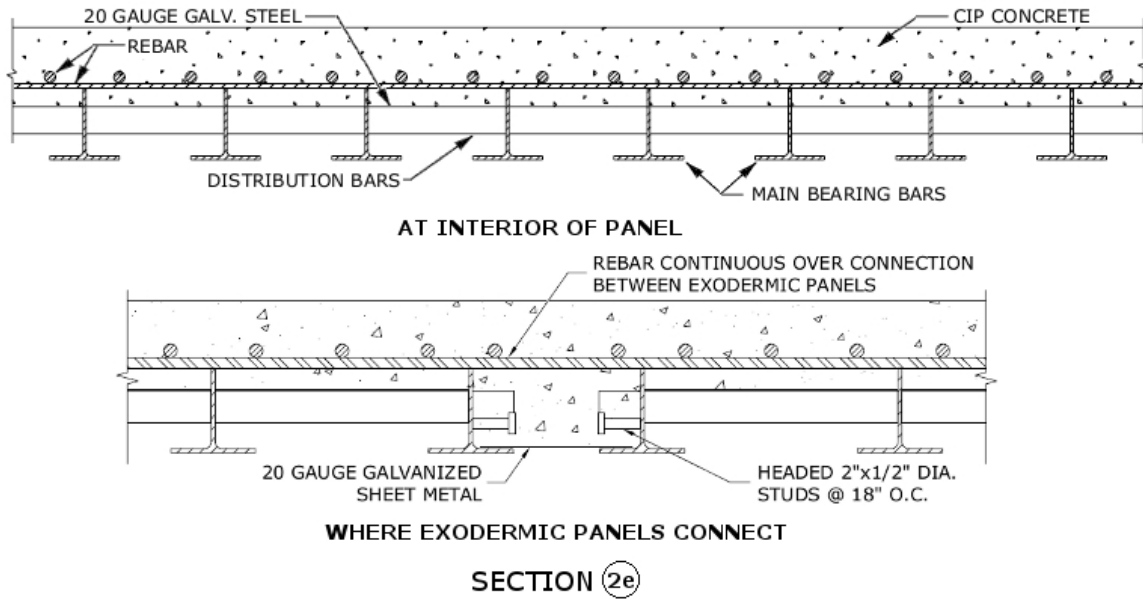

Figure 4.25 Cross-Section Details for Exodermic Cast-in-Place Deck System

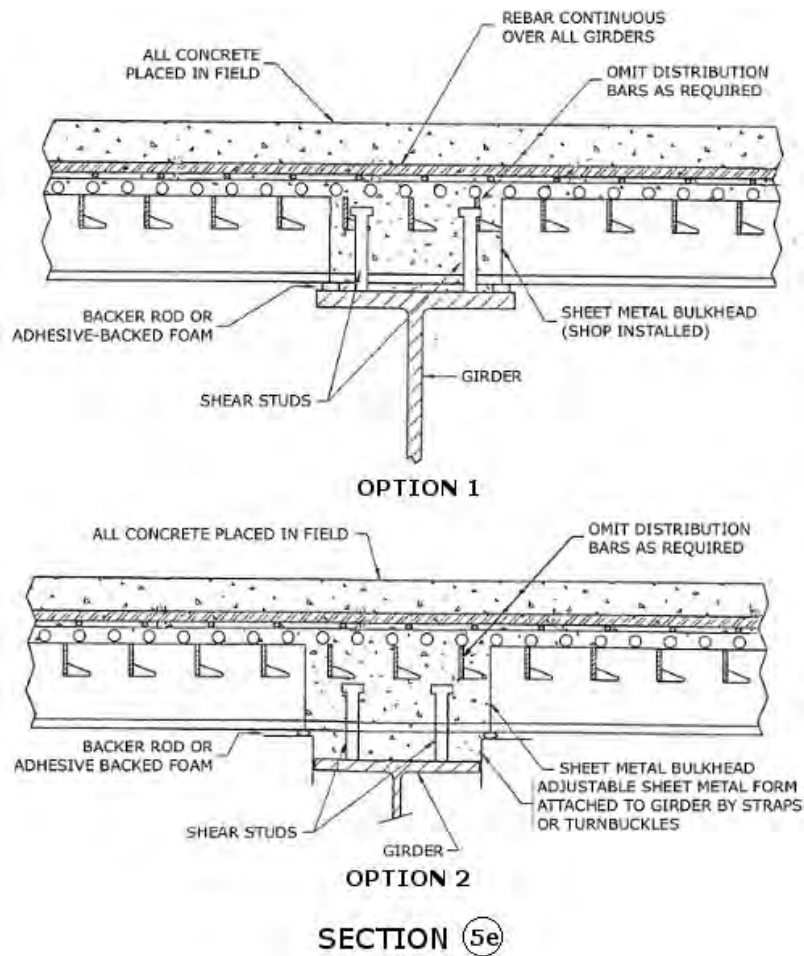

Figure 4.26 Exodermic Cast-in-Place Deck System Girder Attachment Detail

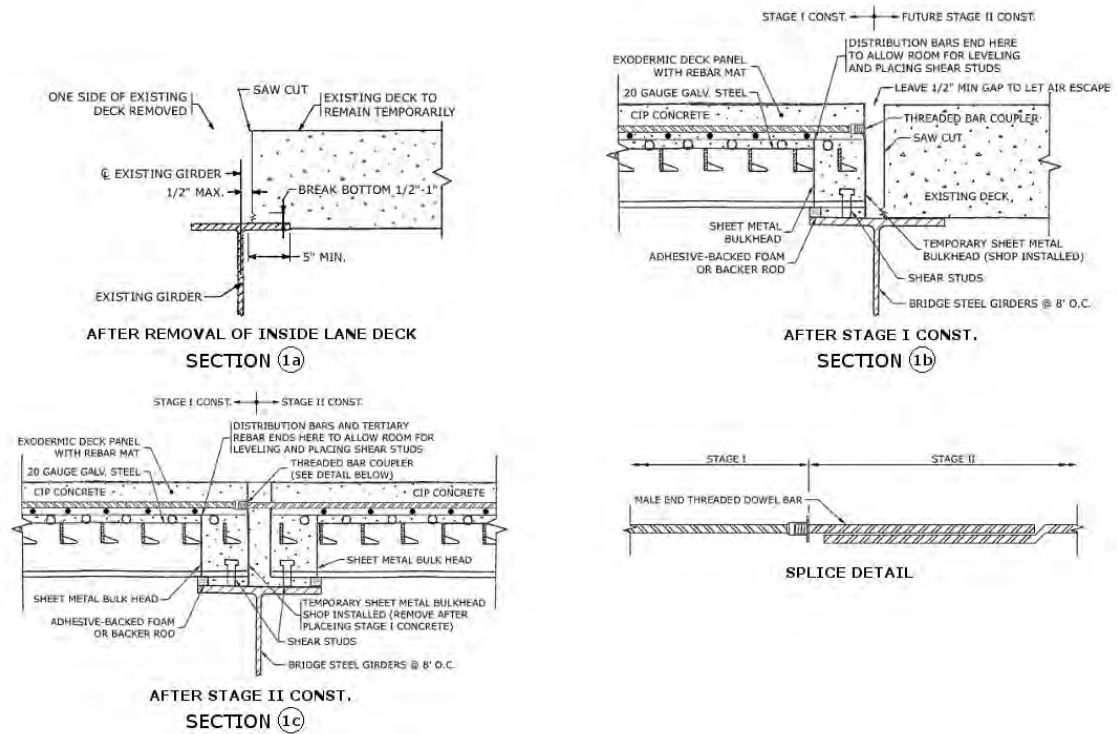

Figure 4.27 Exodermic Cast-in-Place Deck System Staged Construction Joint Details

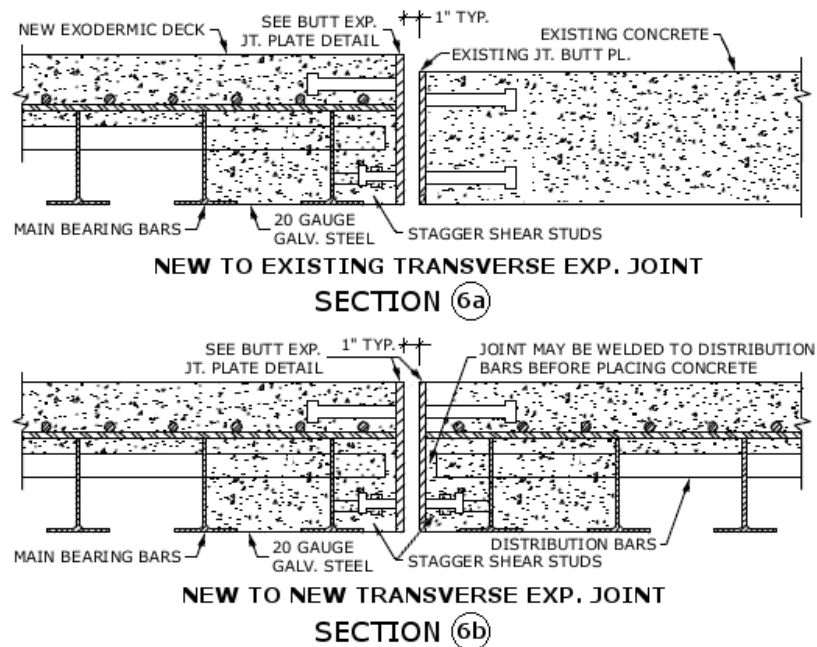

Figure 4.28 Exodermic Cast-in-Place Deck System Expansion Joint Details

4.2.4. Steel Grid Partial-depth Cast-in-Place Deck System

The steel grid partial-depth cast-in-place system is to be installed on Spans 3 & 4 of the Northbound Bridge as shown in Figure 4.2. A preliminary design for this system was chosen from the L.B. Foster fabricated bridge products brochure. The system from this brochure that best suits the sister bridges is the 5-inch RB 6.1 half-filled grid with overfill. Thus, this system was chosen for the preliminary design. The concrete thickness of this system was adjusted to achieve an overall depth of 8 inches. This adjustment was made so that this system will be the same depth as the Exodermic system that is to be installed on the same bridge. This was done for the same reason as the increase in concrete thickness for the Exodermic precast system. That is, to allow for similar deck surface elevations without requiring an unreasonably large haunch. The final design of this deck system is shown in Figure 4.29 & 4.30. Further details, including the conceptual connection details, are shown in Figures 4.31 through 4.37. Barrier rail details are discussed in Section 4.3.

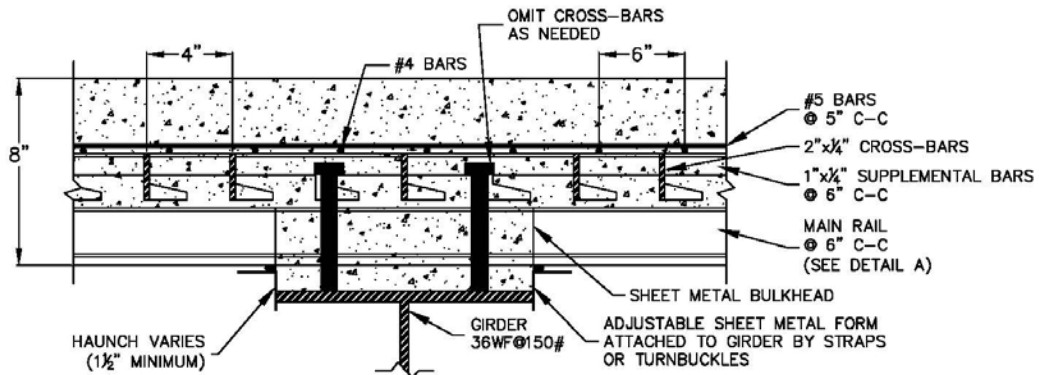

Figure 4.29 Steel Grid Cast-in-Place Deck System Details

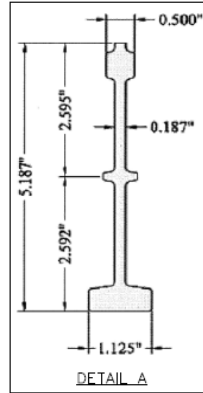

Figure 4.30 Main Rail Dimensions for Steel Grid Cast-in-Place Deck System

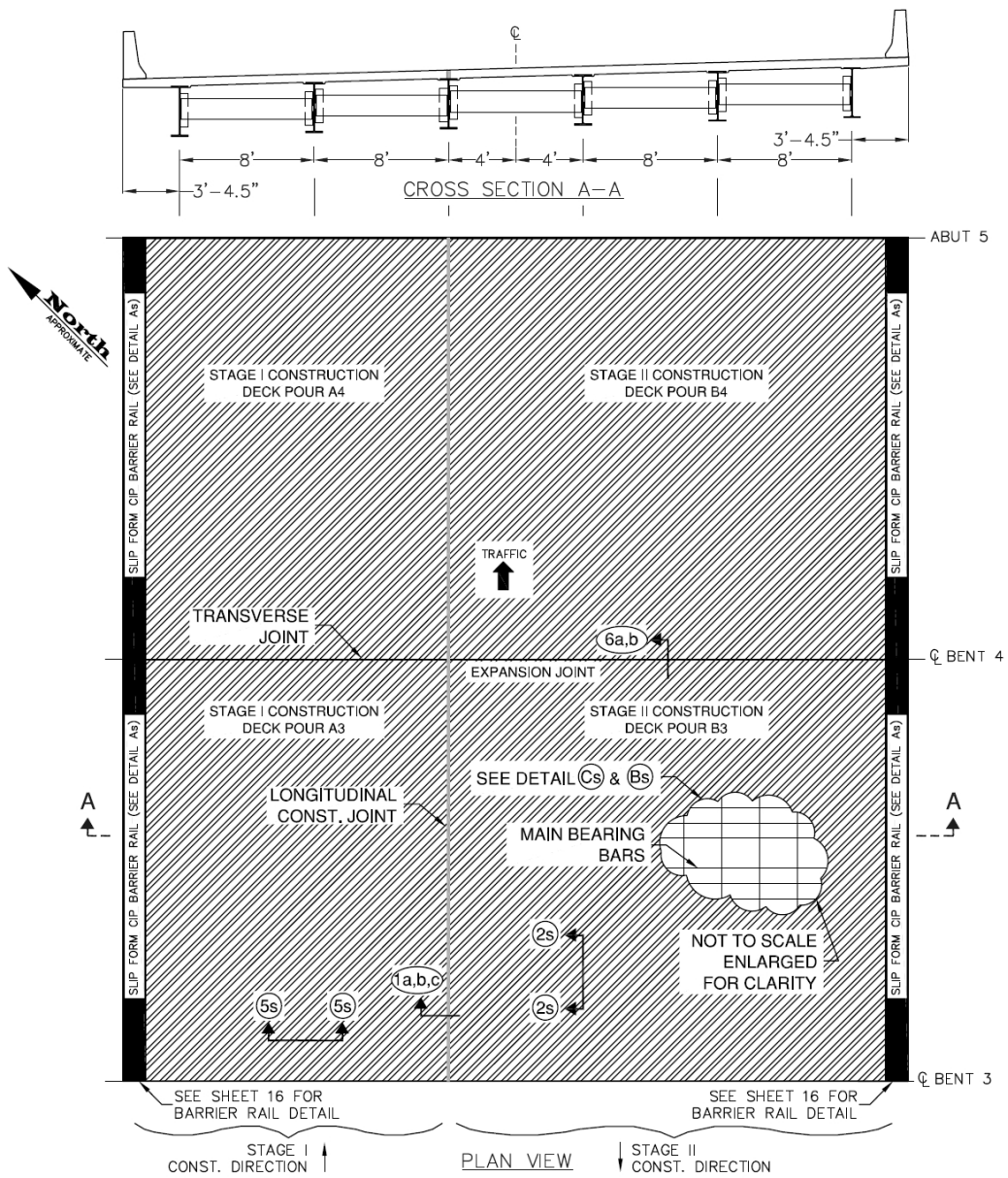

Figure 4.31 Plan View of Steel Grid Cast-in-Place Deck System

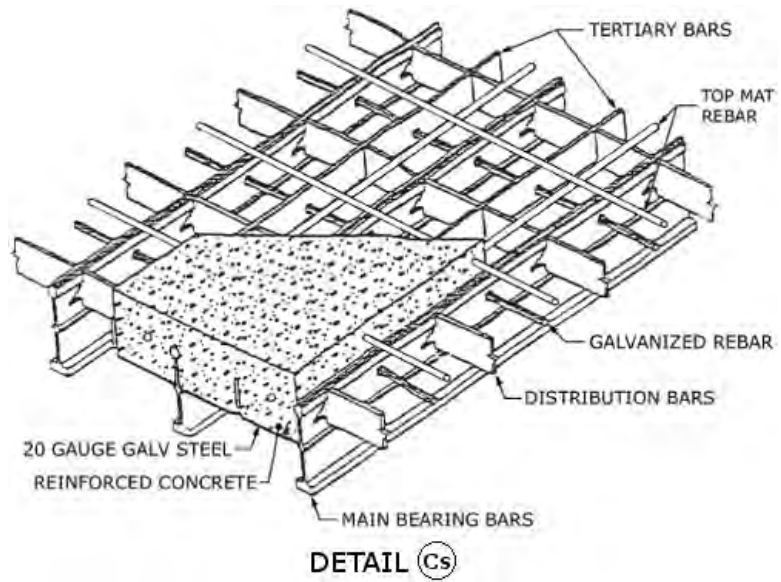

Figure 4.32 Isometric View of Steel Grid Cast-in-Place Deck System

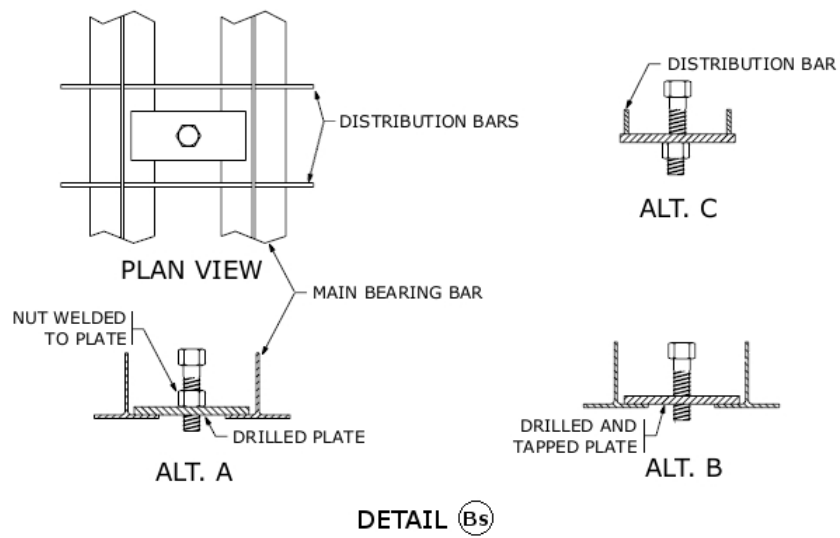

Figure 4.33 Steel Grid Cast-in-Place Deck System Panel Height Adjustment Details

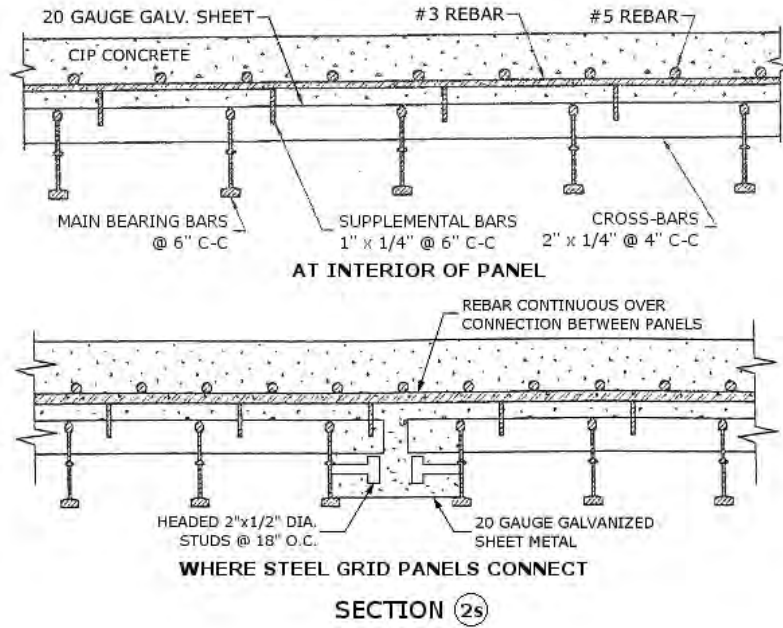

Figure 4.34 Cross-Section Details for Steel Grid Cast-in-Place Deck System

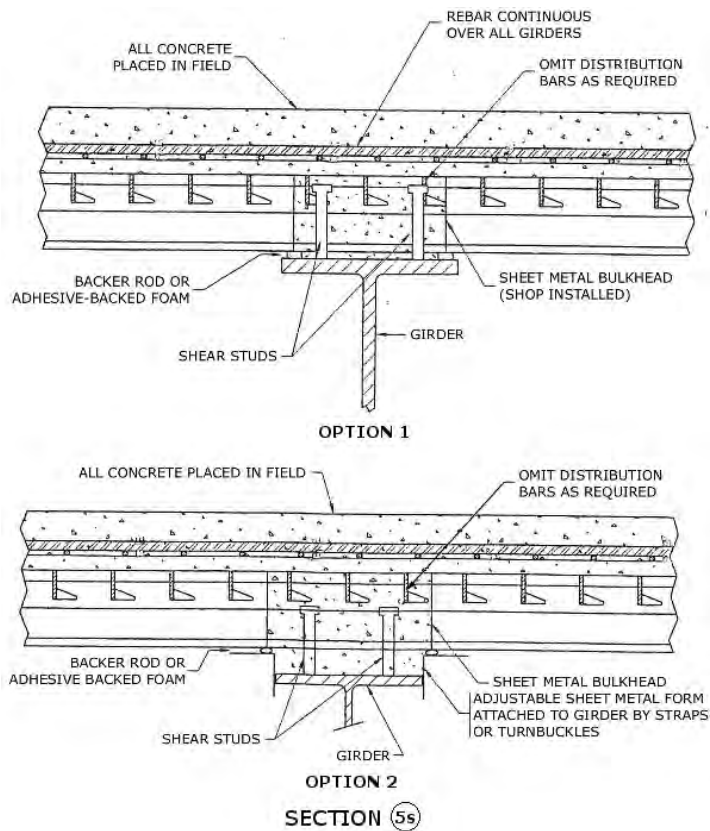

Figure 4.35 Steel Grid Cast-in-Place Deck System Girder Attachment Details

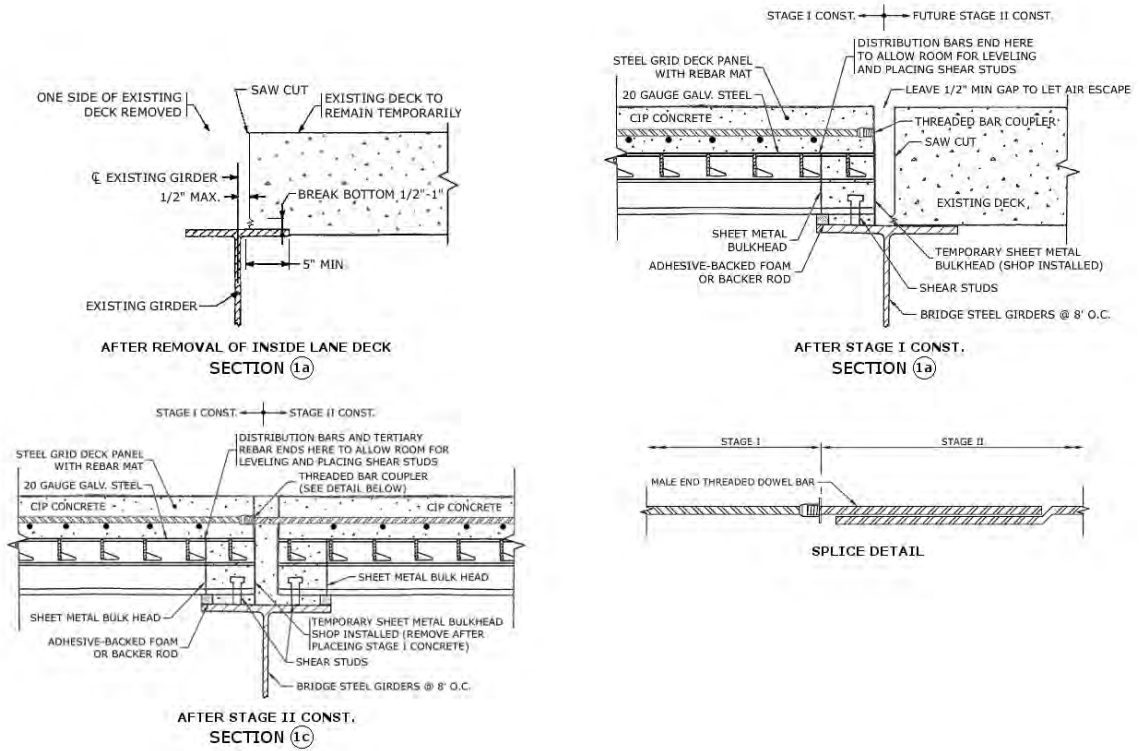

Figure 4.36 Steel Grid Cast-in-Place Deck System Staged Construction Joint Details

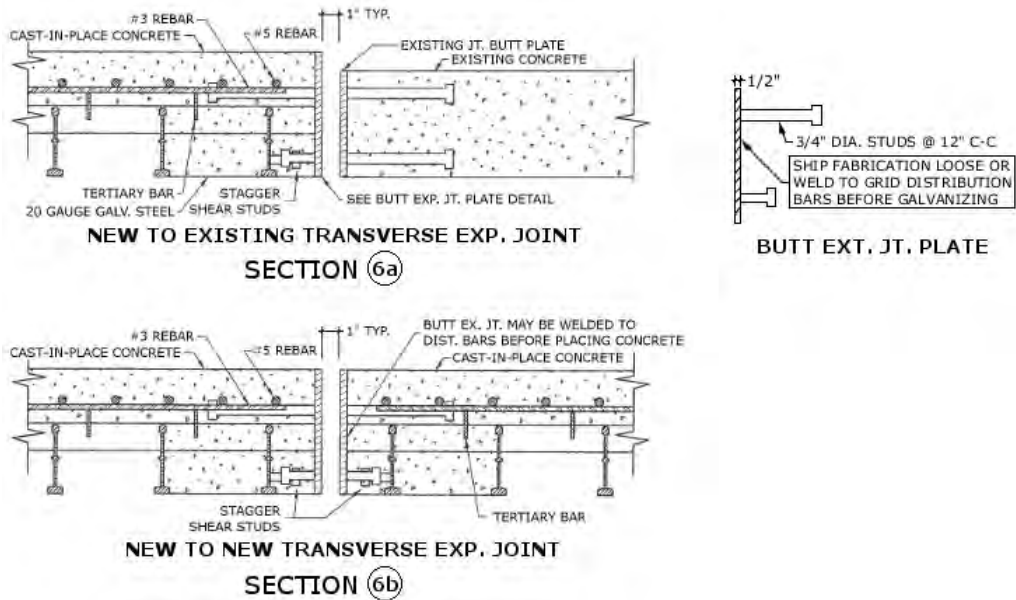

Figure 4.37 Steel Grid Cast-in-Place Deck System Expansion Joint Details

4.3. Proposed Barrier Rail

A barrier rail must be chosen for use on the sister bridges. There are several options available including precast and cast-in-place barrier rails. The considerations for comparison of these rails include average weight per length, curb width, and other various pros and cons. The average weight per length is approximated due to scaled dimensions from details. Minor components were also ignored in the weight calculations such as anchor bolts. The barrier rails that were compared are listed below and a typical cross-section for each is shown in Figures 4.38 through 4.44.

Precast Rails:

1. L.B. Foster Precast NJ-Shape (Figure 4.38)
2. D.S. Brown Precast Barrier Rail (Figure 4.39)

Cast-In-Place Rails:

3. ALDOT Standard Barrier Rail (Figure 4.40)
4. Concrete Jersey Safety Shape Bridge Rail (Figure 4.41)
5. 32-in Vertical Concrete Parapet (Figure 4.42)
6. Missouri 30-in New Jersey Concrete Barrier (Figure 4.43)
7. F-Profile Bridge Railing (Figure 4.44)

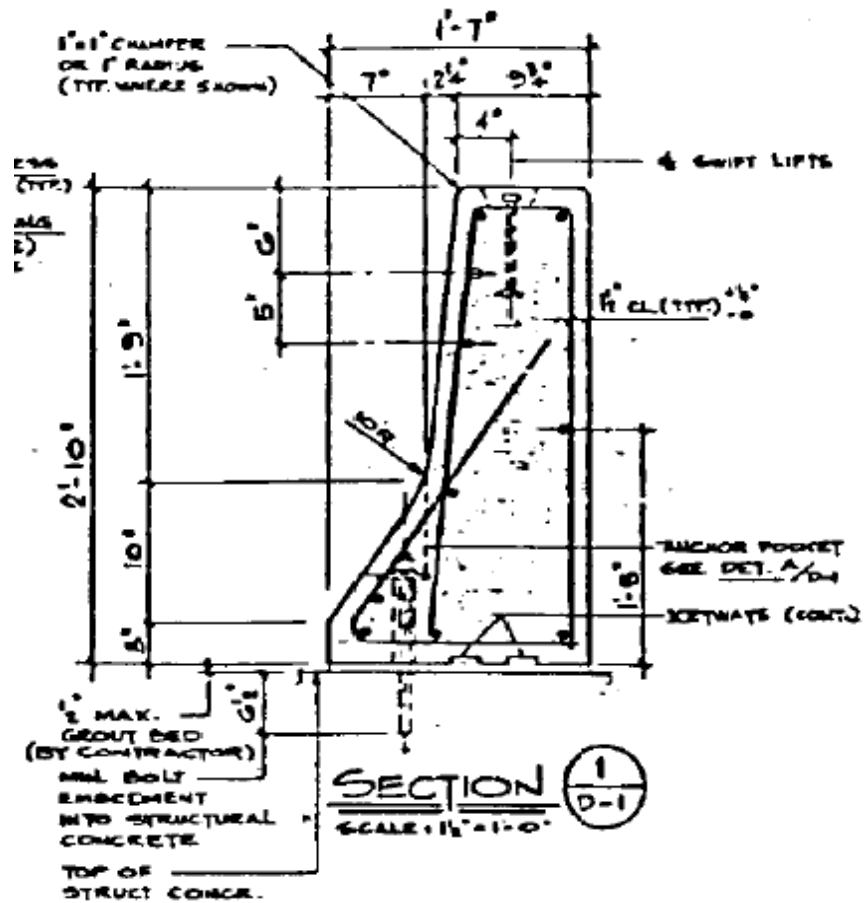

Figure 4.38 L.B. Foster Precast NJ-Shape (FHWA 1997)

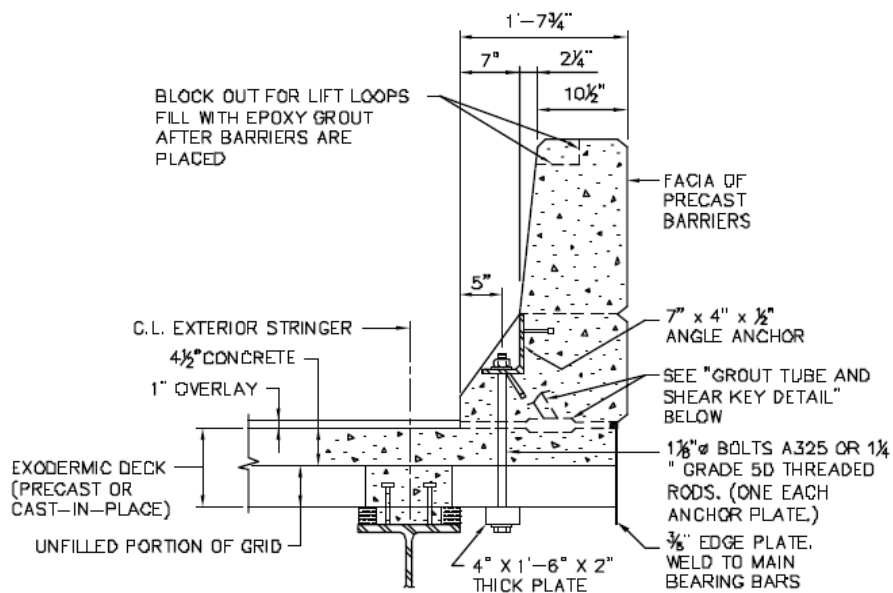

Figure 4.39 D.S. Brown Precast Barrier Rail

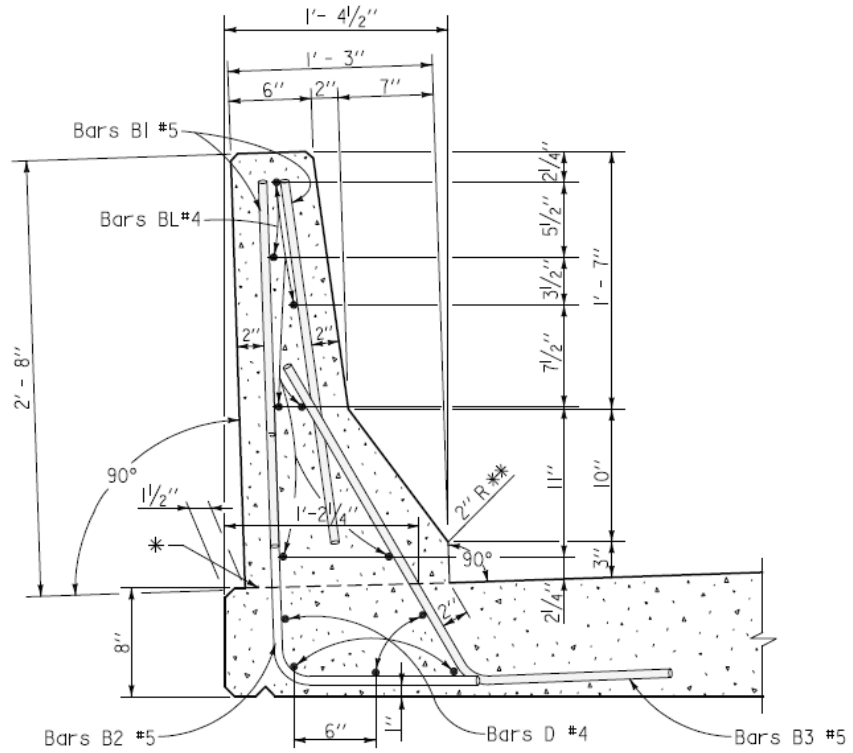

Figure 4.40 ALDOT Standard Barrier Rail

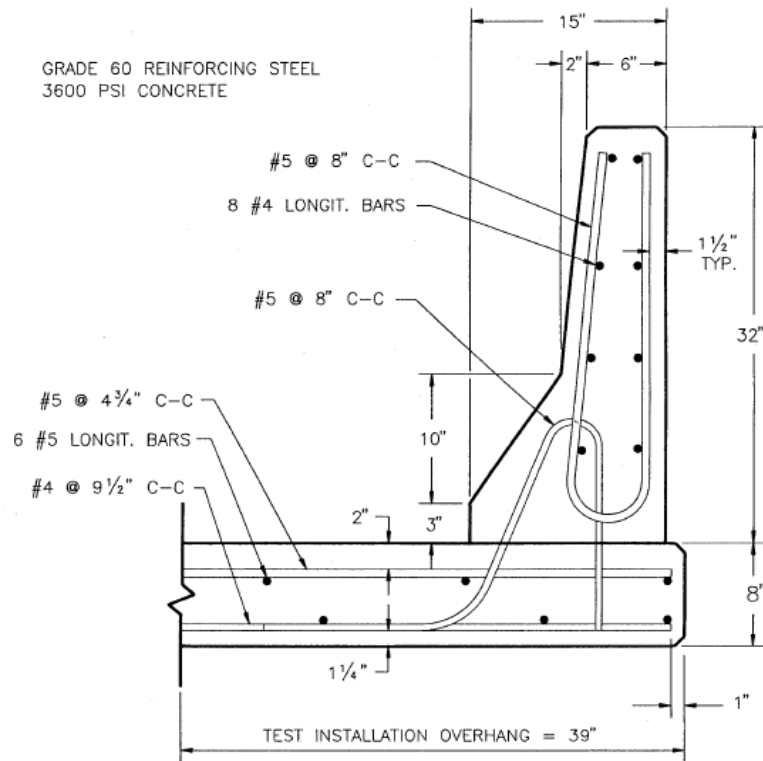

Figure 4.41 Concrete New Jersey Safety Shape Bridge Rail (FHWA 1997)

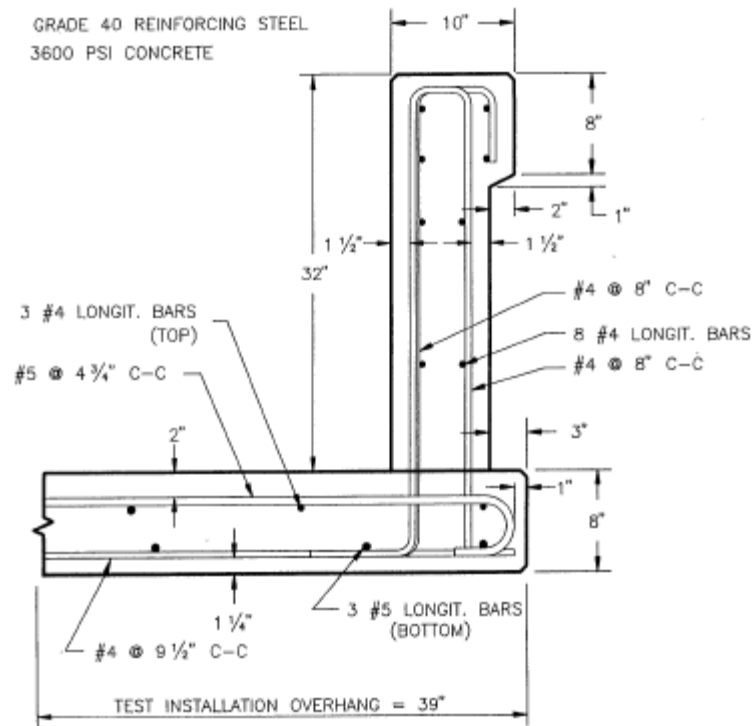

Figure 4.42 32-in Vertical Concrete Parapet (FHWA 1997)

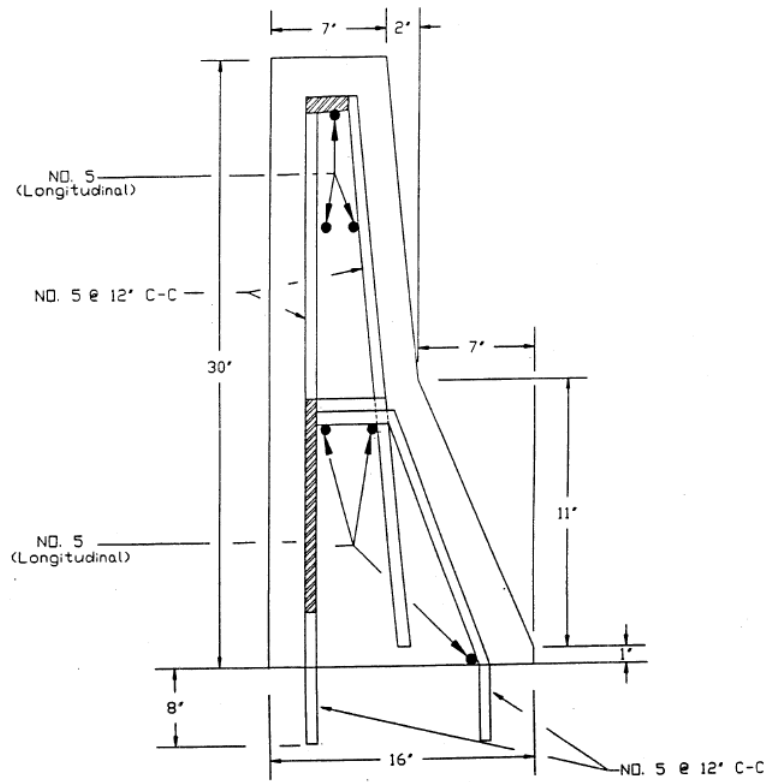

Figure 4.43 Missouri 30-in New Jersey Concrete Barrier (FHWA 1997)

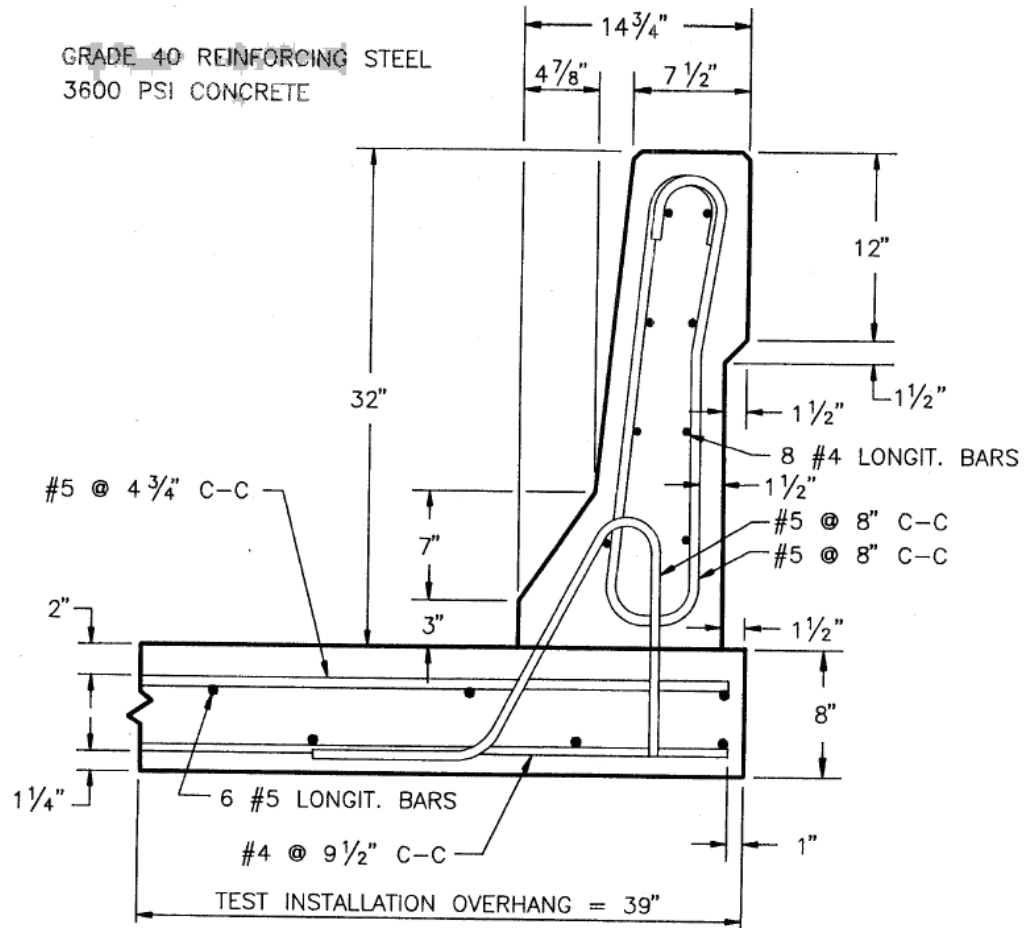

Figure 4.44 F-Profile Bridge Railing (FHWA 1997)

A summary of these barrier rails is shown in Table 4.1. The test rating for some of these barrier rails are unknown; However, AASHTO Section 13.7.2 requires the barrier rails for the sister bridges to be at least test level four (TL-4) since the rails are to be installed on an Interstate highway. Barrier rails that have not been verified to be at least TL-4 rated should not be considered.

Table 4.1 Summary of Barrier Rails

	Barrier Rail	Barrier Type	Test Rating	Avg Wt. (plf)	Curb Width (in)
	Existing	NA	N/A	118	12.00
1	L.B. Foster Precast NJ-Shape	Precast	TL-4	459	19.00
2	D.S. Brown Precast Barrier Rail	Precast	N/A	492	19.75
3	ALDOT Standard Barrier Rail	Cast-In-Place	N/A	304	16.50
4	Concrete Jersey Safety Shape Bridge Rail	Cast-In-Place	TL-4	314	15.00
5	32-in Vertical Concrete Parapet	Cast-In-Place	TL-4	310	11.00
6	Missouri 30-in New Jersey Concrete Barrier	Cast-In-Place	TL-4	331	16.00
7	F-Profile Bridge Railing	Cast-In-Place	TL-4	325	14.75

All of these barrier rails are much heavier than the existing barrier rail. The average weight of the existing barrier rail was estimated to be 118 pounds per linear foot. The test rating of the existing rail is unknown, but it is presumably not a TL-4 rating due to it being very light compared to the other rails. It is assumed that current barrier rail requirements are more stringent than those that were in effect when the existing barrier rail was selected.

It is common to design all of the girders to evenly carry the load of the barriers, but in reality, the exterior girders carry the bulk of the load. The new girders that will be added to widen the bridge can be designed to carry the full barrier load (not distributing the load evenly among all of the girders). Thus the increase in barrier weight isn't a concern. Even though the exterior girders can be designed to carry the full load of the barrier rails, it is still economical to select the lightest feasible option.

Since there is room to open all lanes up to traffic and still have room to pour the cast-in-place barriers, precast barriers are not required for this project. Precast barriers would typically aid in rapid construction, but due to the bulkiness of them compared to the cast-in-place barriers (about a 150-plf difference), it is suggested to use one of the cast-in-place barrier rail options. Of the cast-in-place options, the ALDOT Standard Barrier Rail is the lightest. The only problem with this barrier is that the curb width is fairly large compared to the other choices. Since the bridge is being widened to a total horizontal width of 46'-9", there would be enough space for three 14' wide lanes and two 28.5 inches wide barriers (neglecting shoulders). The maximum barrier width is 16.5 inches considering a one-foot shoulder on each side of the bridge. So the width of the ALDOT Standard Barrier Rail is okay.

Details for the ALDOT standard barrier rail are shown in Figures 4.45 through 4.49. Figures 4.46 through 4.49 show conceptual details for connecting the ALDOT standard barrier rail to the four deck systems.

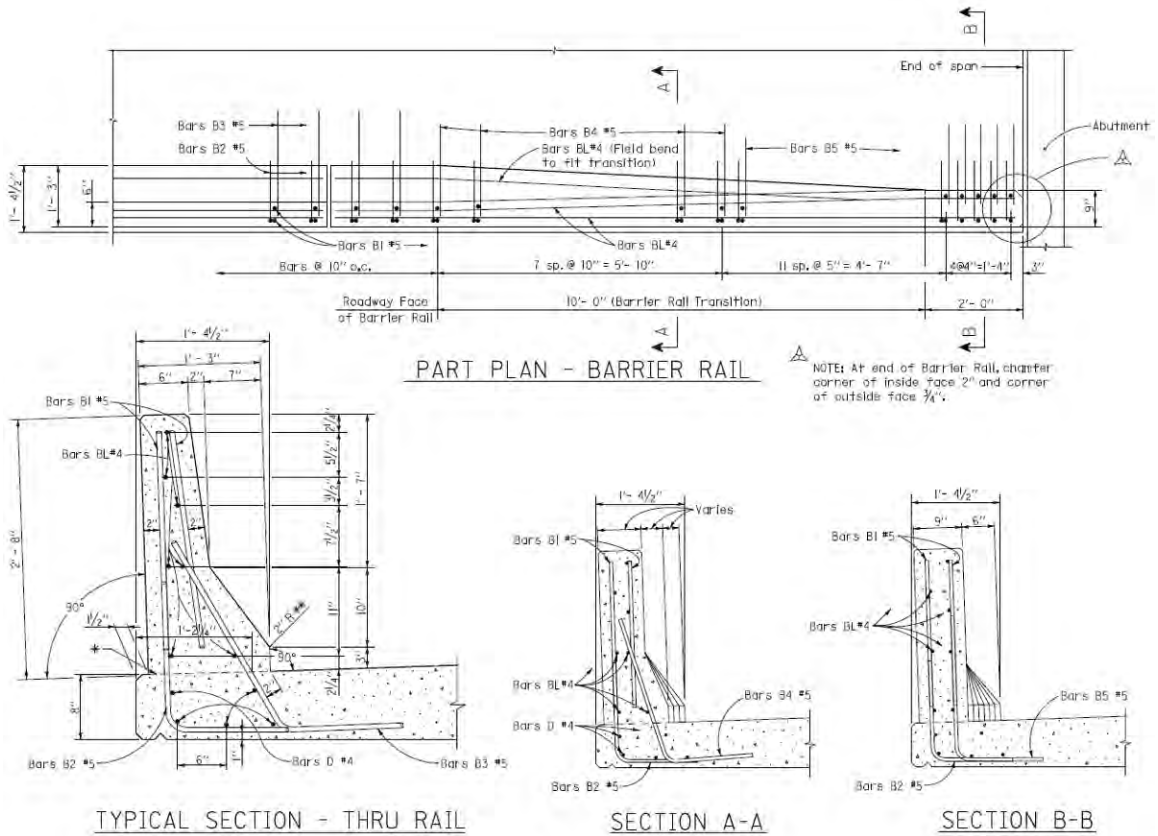

DETAIL (A)

Figure 4.45 ALDOT Standard Barrier Rail Details

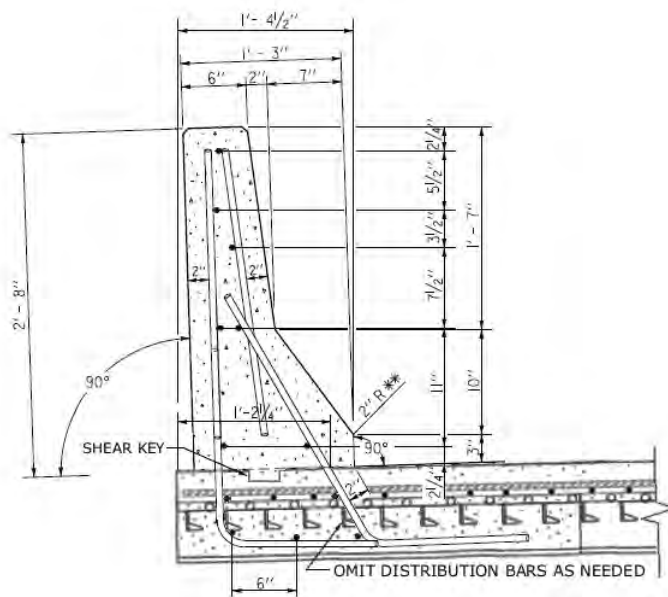

DETAIL (Ae)

Figure 4.46 Barrier Connection Details for the Exodermic Cast-in-Place Deck System

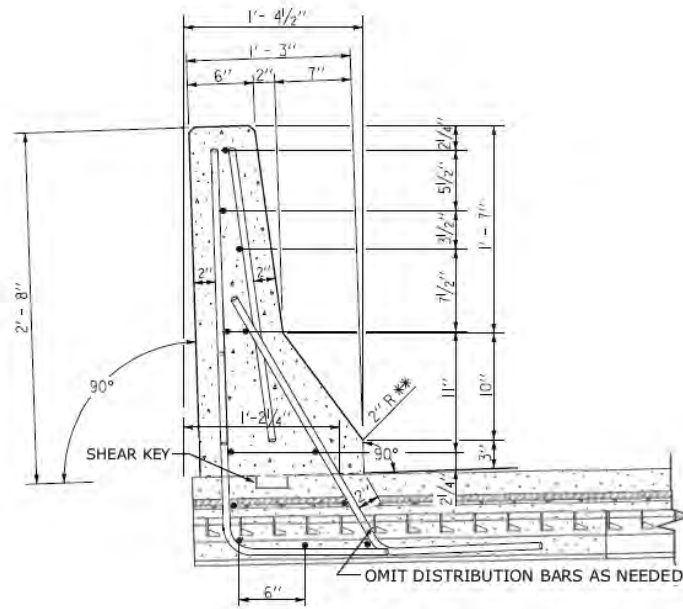

DETAIL (As)

Figure 4.47 Barrier Connection Details for the Steel Grid Cast-in-Place Deck System

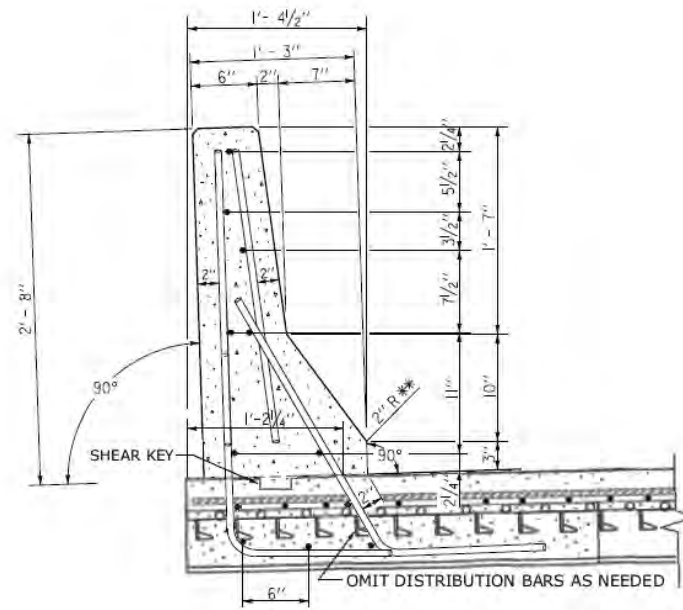

DETAIL (Ax)

Figure 4.48 Barrier Connection Details for the Exodermic Precast Deck System

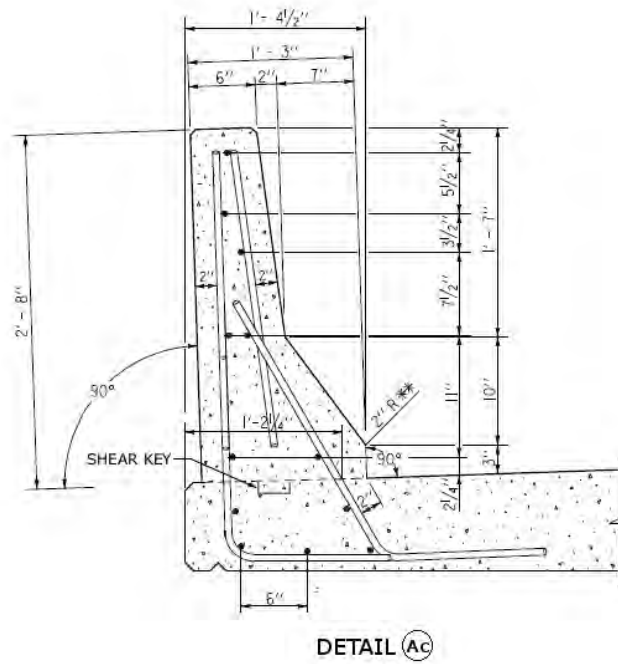

Figure 4.49 Barrier Connection Details for the NCHRP Full-Depth Precast Deck System

5. Proposed Sequence of Deck Replacement

5.1. General

Understanding the construction sequence is necessary in order to determine the load effect imposed upon the bridges. Different loads apply to different cross-sections at different stages during the construction process. The deck systems must be designed to withstand the loads carried throughout the entire construction as well as the loads on the final cross-section.

The construction sequence for each of the bridges varies. The northbound bridge (NBR Bridge) will contain both of the cast-in-place systems while the southbound bridge (SBR Bridge) will contain both of the precast systems (see Figure 5.1). Each system will be used over two spans. The two cast-in-place systems are to be installed in Stages I and II while the two precast systems are to be installed in Stages III and IV. Both of the bridges will also be widened during the construction process. This widening will provide each bridge with a shoulder as well as room to install Jersey barrier rails.

In describing Stage I through Stage IV construction sequences in the following sections, terminology such as outside lane, inside lane, direction of traffic, and other bridge/traffic conditions are referred to. These are explained below as well as other notes to be considered.

1. Outside lane is the lane away from the median strip, i.e., the right lane when looking in the direction of traffic
2. Inside lane is the lane adjacent to the median strip, i.e., the left lane when looking in the direction of traffic

3. Work shall progress in the direction of traffic for Stage I & Stage III construction (replacing the inside lane of deck)
4. Work shall progress in the direction opposing traffic for Stage II & Stage IV construction (replacing the outside lane deck)
5. Diaphragms are not shown on plan views to improve readability
6. The NBR Bridge will be a 1-lane bridge throughout Stage I construction
7. The SBR Bridge will be a 1-lane bridge throughout Stage III construction
8. Stage IV deck replacement progress may be constrained to allow for the evaluation of deck joints under traffic conditions

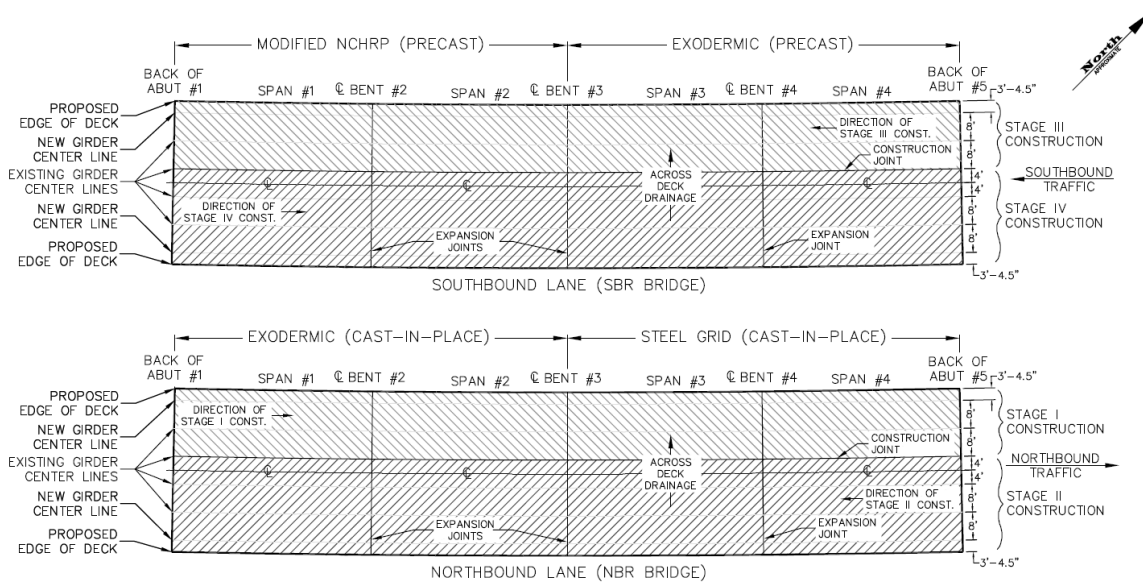

Figure 5.1 Plan View of Proposed Layout

5.2. Stage I Construction

The existing deck of the inside lane portion of the northbound bridge is replaced in Stage I. Figures 5.2 through 5.8 depict the tasks to be completed for the Stage I construction. Work during this stage shall progress in the direction of traffic. A description of the Stage I tasks and figures are as follows.

The first task is to install new girder lines on the north side of the bridge for all four spans as shown in Figure 5.2. Traffic is maintained in both lanes during this task. Task 2 is to place temporary barriers for the full length of the bridge and close down the inside lane of traffic as shown in Figure 5.3. Once traffic is closed to the inside lane, the inside lane portion of the existing deck shall be demolished for the full length of the bridge as shown in Figure 5.4. This is Task 3 of Stage I. The new Exodermic deck panels can now be installed in Span 1. This is Task 4 of Stage I and is accomplished by executing the following for the full length of Span 1; Working in the direction of traffic, place the unfilled Exodermic steel deck panels, place deck top reinforcement mat, place span end steel plates, and then place rapid-setting concrete on the deck panels. This is depicted in Figure 5.5. This same process is then repeated for Span 2 as shown in Figure 5.6 for Task 5. The next task, Task 6, is to install the barrier rails for Spans 1 and 2. Working in the direction of traffic, place the barrier rail reinforcing steel, place the barrier slip forms, and cast the barrier rail concrete. This is shown in Figure 5.7. Tasks 4 through 6 are then repeated for Spans 3 and 4 using standard steel grid panels rather than Exodermic panels as shown in Figure 5.8. This is Task 7 of Stage I and concludes the Stage I construction.

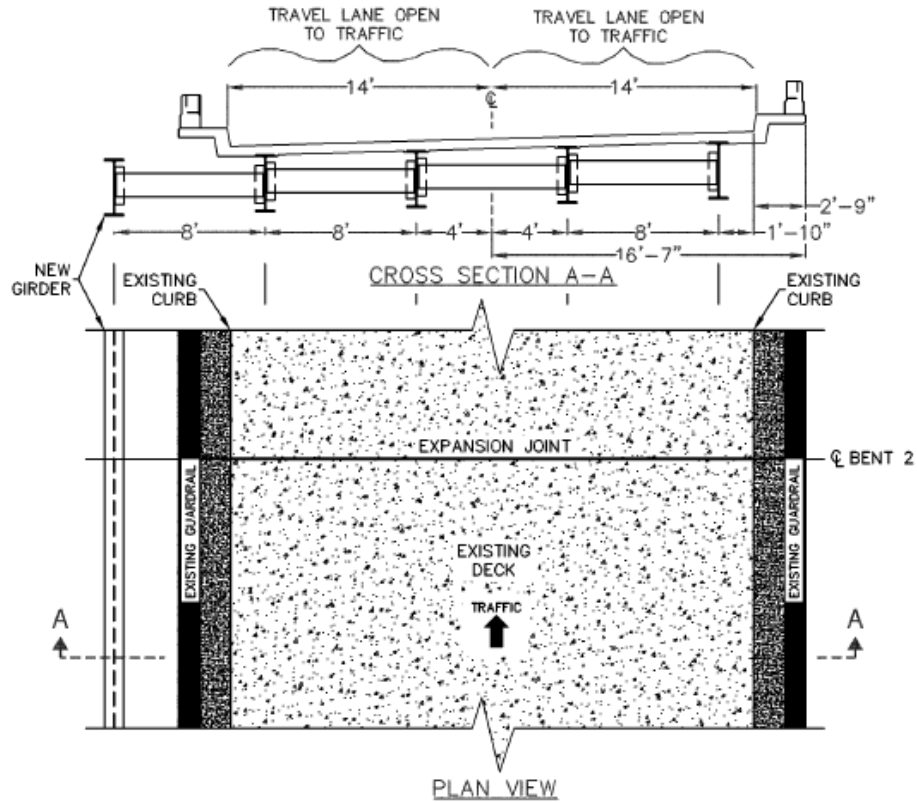

Figure 5.2 Construction Sequence, Stage I - Task 1

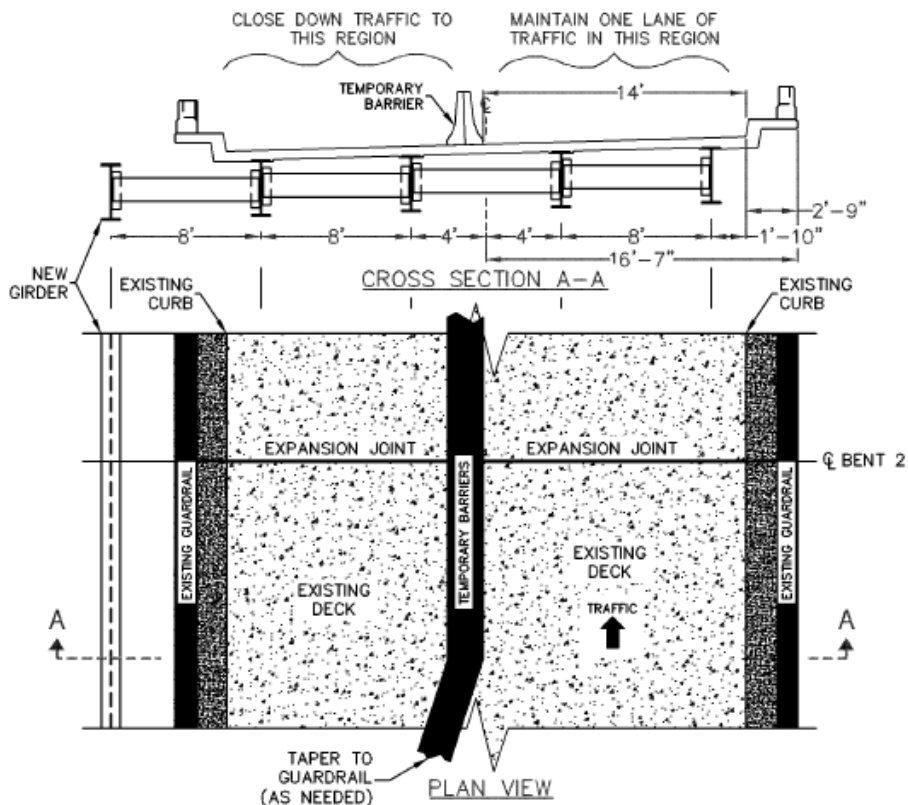

Figure 5.3 Construction Sequence, Stage I - Task 2

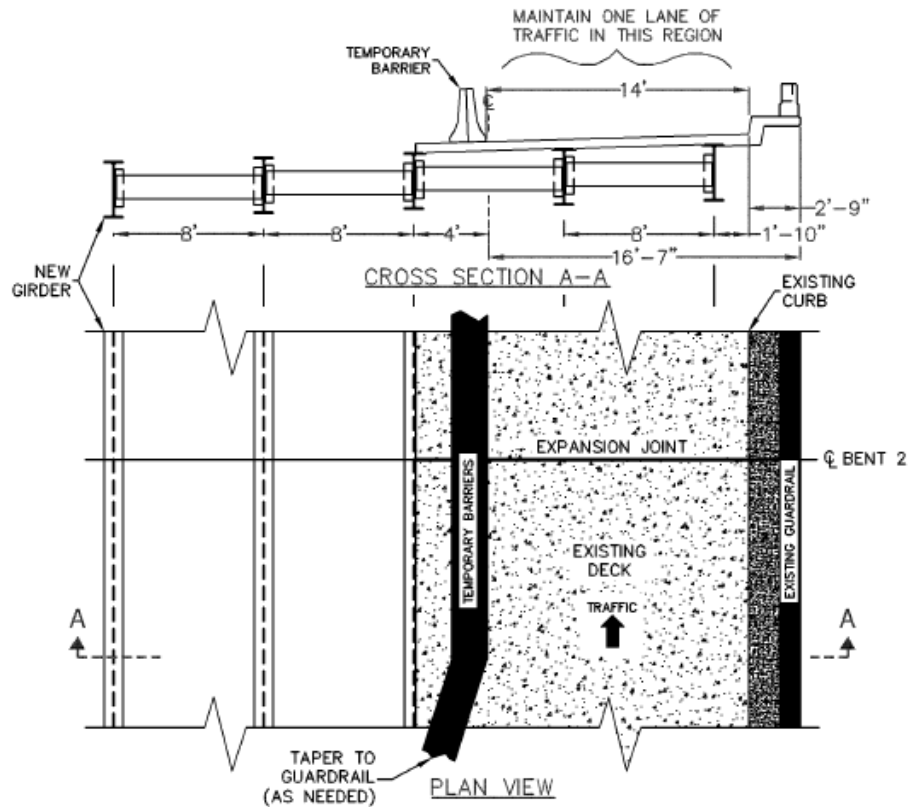

Figure 5.4 Construction Sequence, Stage I - Task 3

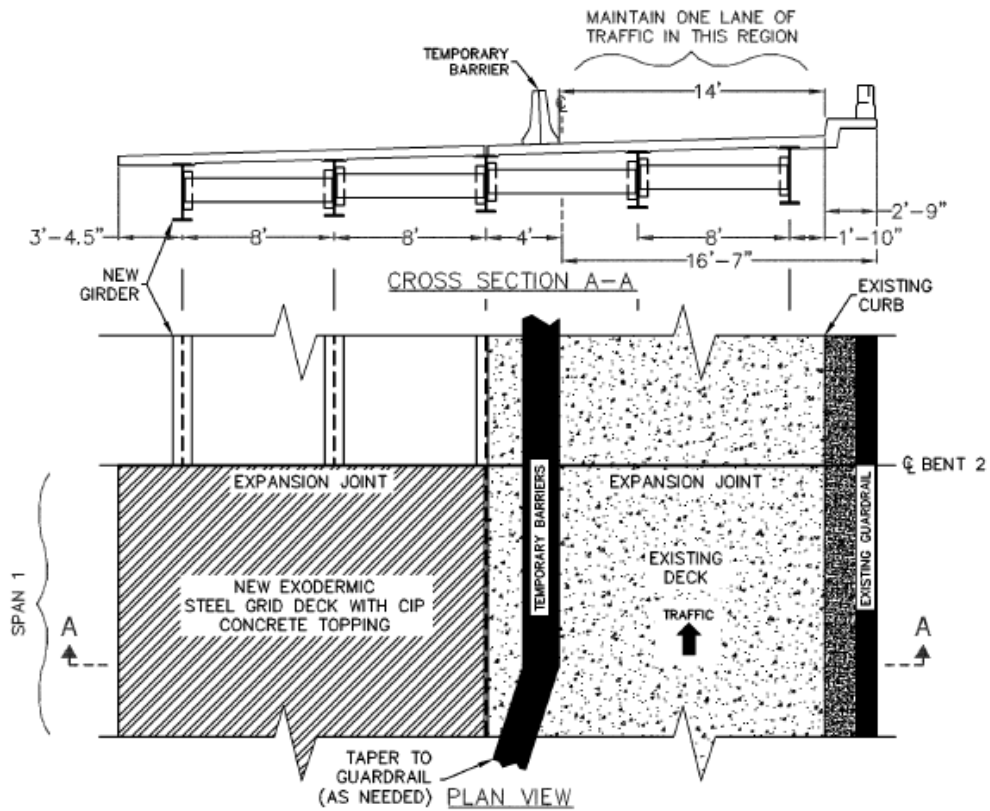

Figure 5.5 Construction Sequence, Stage I - Task 4

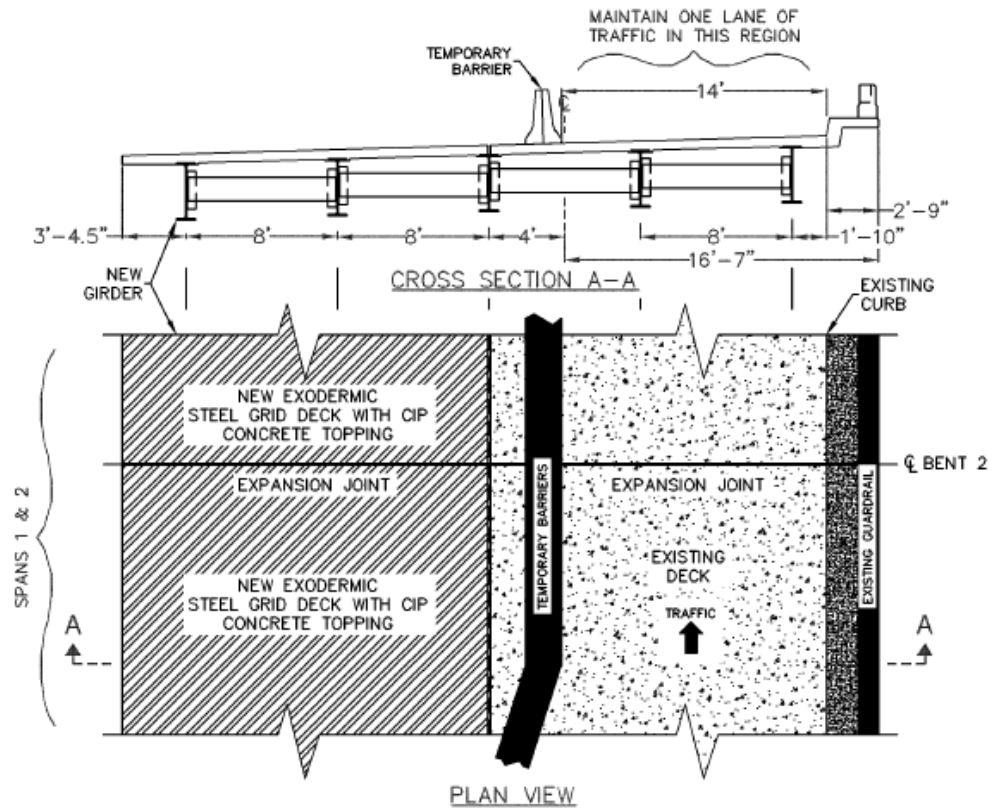

Figure 5.6 Construction Sequence, Stage I - Task 5

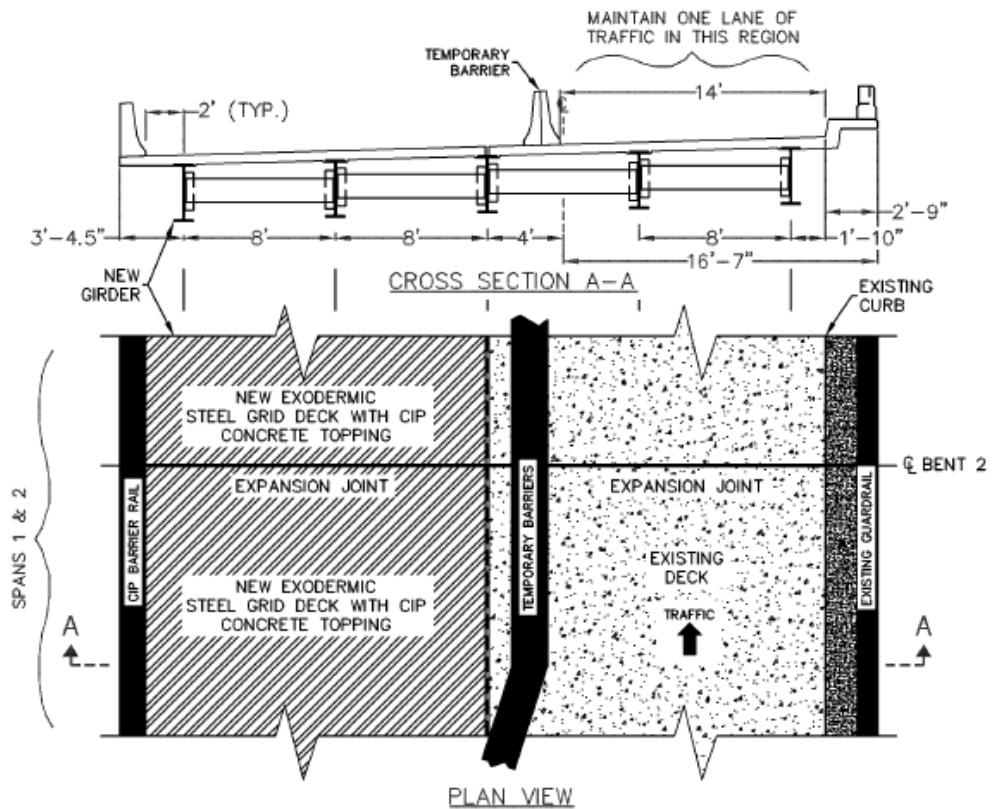

Figure 5.7 Construction Sequence, Stage I - Task 6

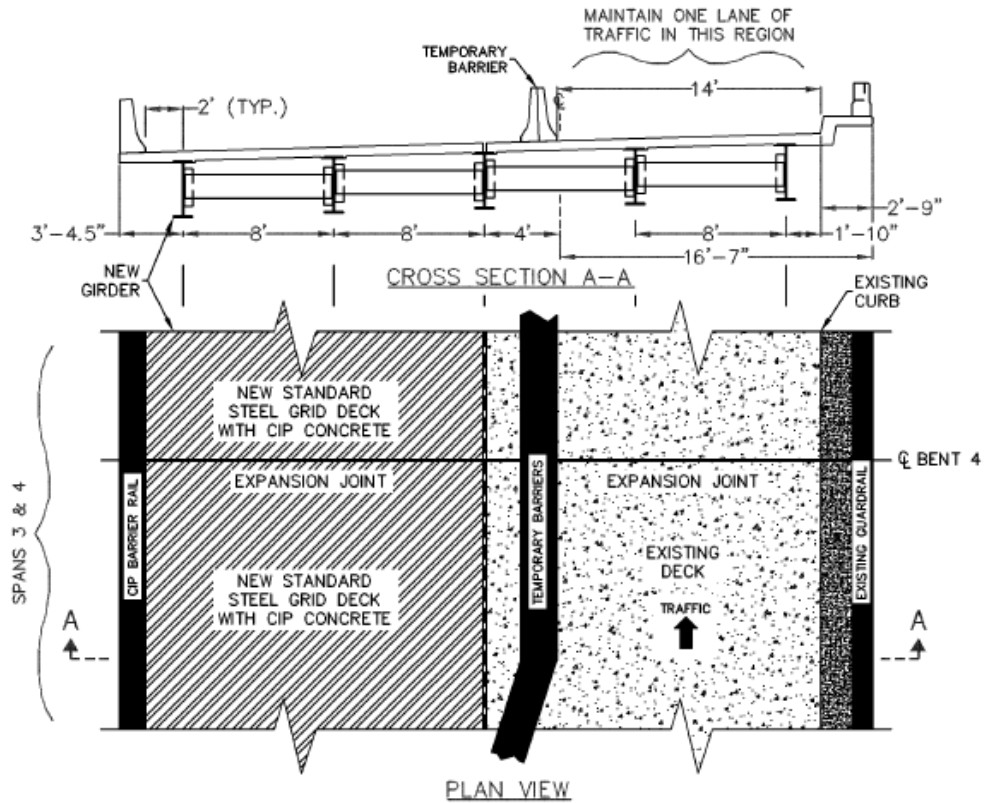

Figure 5.8 Construction Sequence, Stage I - Task 7

5.3. Stage II Construction

The existing deck of the outside lane portion of the northbound bridge is replaced in Stage II. This construction stage will replace the remaining portion of the existing deck. Figures 5.9 through 5.17 show the different tasks to be completed during the Stage II construction. Work for this stage shall progress in the direction opposing traffic. A description of the Stage II tasks and figures are as follows.

The first task of Stage II is to install new girder lines on the south side of the bridge for all four spans as shown in Figure 5.9. Tasks 2 and 3 is to relocate and add temporary barriers as necessary to redirect traffic from the outside lane to the inside lane. This will close down traffic to the outside lane so the existing deck can be replaced. This is shown in Figure 5.10. The next task, Task 4, is to demolish the existing deck of the outside lane

of Span 4 as illustrated in Figure 5.11. Once the old deck is removed, the new deck panels can be installed. Task 5 involves installing the unfilled standard steel grid deck panels, deck top reinforcing bar mat, span end steel plates, and placing rapid-setting concrete on the deck panels where the deck was removed. A representation of Task 5 is shown in Figure 5.12. Once the new deck is installed in Task 5, traffic may be opened up to two lanes. In order to do this, additional temporary barriers are to be added as necessary and equipment is to be removed. This is Task 6 and is shown in Figure 5.13. During the next work period, Task 2 through 6 shall be repeated for Span 3. This is Task 7 and is shown in Figure 5.14. The barrier rails must be installed for Spans 3 and 4 once the new decking is in place. This is Task 8 and is accomplished by placing the barrier rail reinforcing steel, placing the barrier slip forms, and casting the barrier rail concrete. This is shown in Figure 5.15. Tasks 2 through 8 are to then be repeated for Spans 1 and 2 using steel Exodermic deck panels rather than the standard steel grid panels. This is Task 9 and is shown in Figure 5.16. After Task 9 is completed, all temporary barriers and equipment is to be removed and traffic is to be opened to two lanes. This is Task 10 and concludes the Stage II construction. The final view of the northbound bridge is shown in Figure 5.17. The construction on the northbound bridge is now complete.

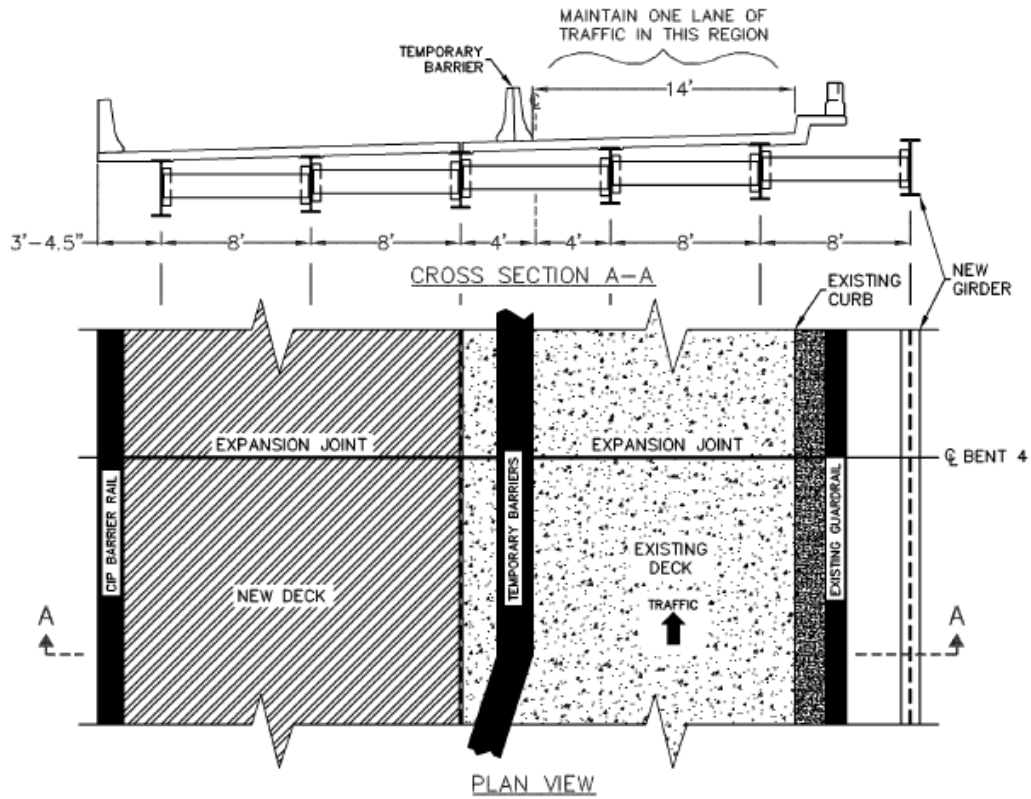

Figure 5.9 Construction Sequence, Stage II - Task 1

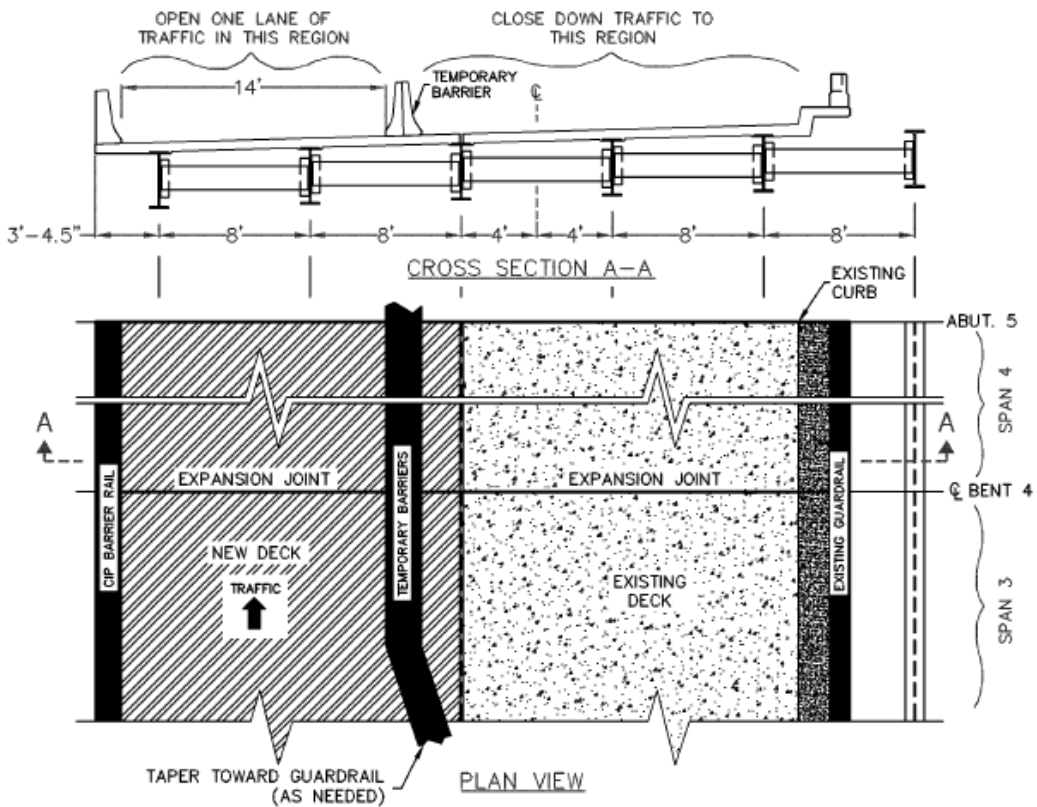

Figure 5.10 Construction Sequence, Stage II - Tasks 2 & 3

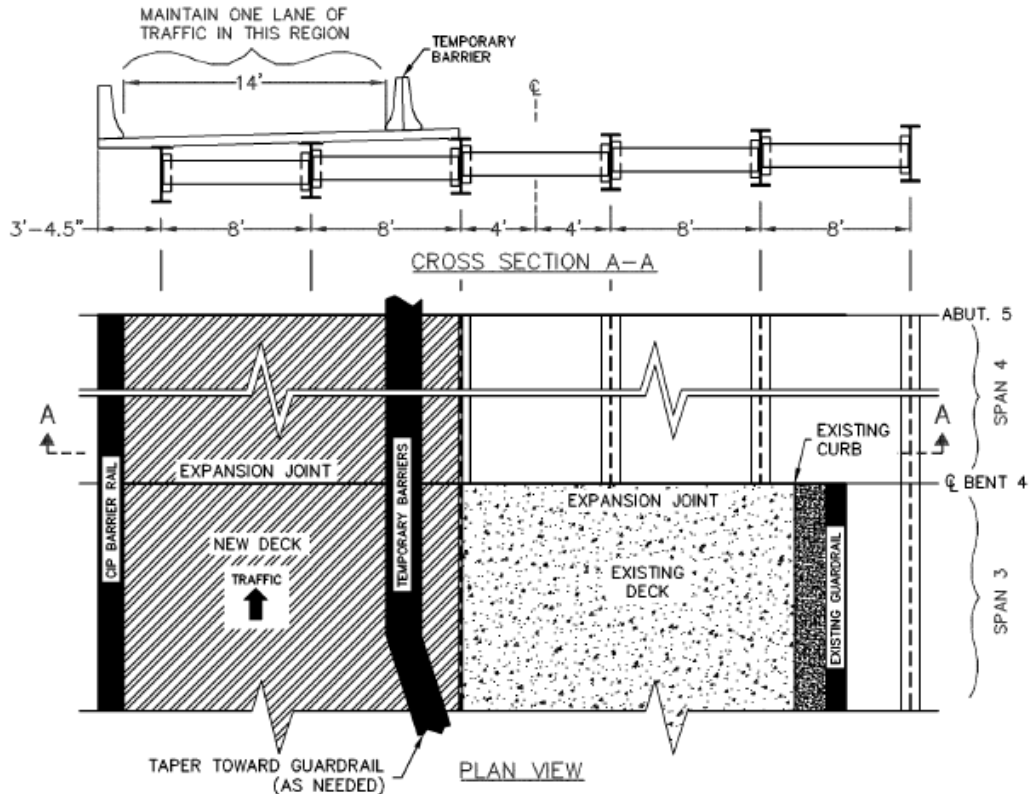

Figure 5.11 Construction Sequence, Stage II - Task 4

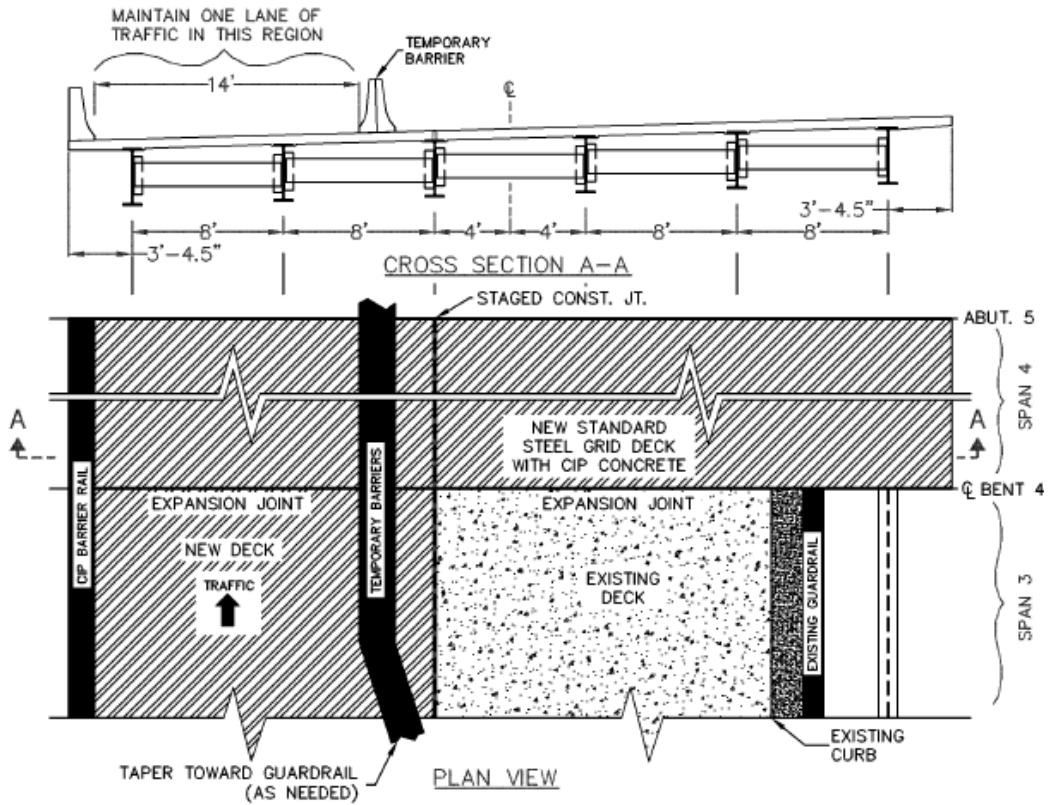

Figure 5.12 Construction Sequence, Stage II - Task 5

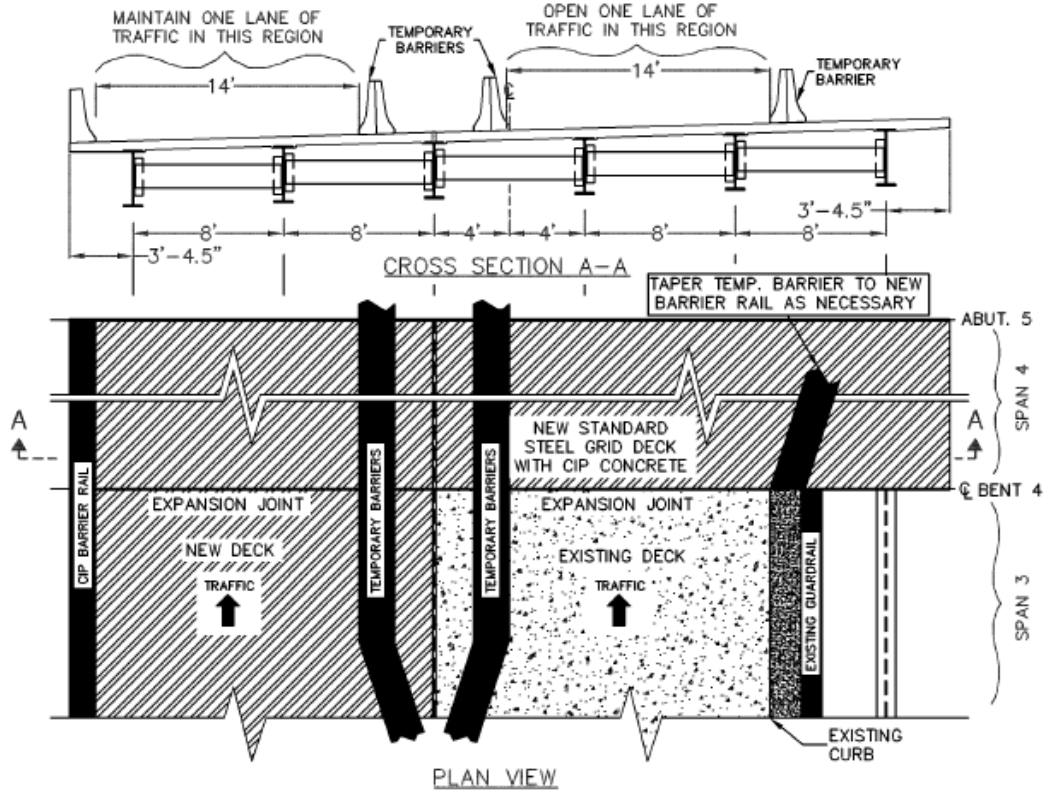

Figure 5.13 Construction Sequence, Stage II - Task 6

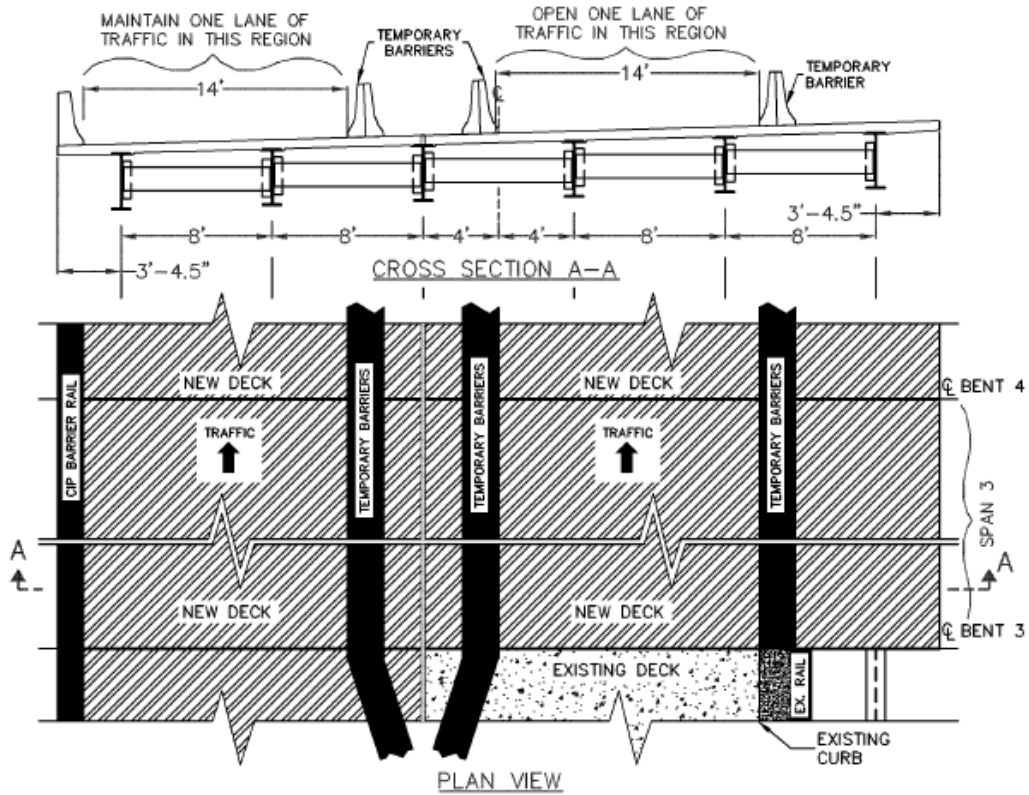

Figure 5.14 Construction Sequence, Stage II - Task 7

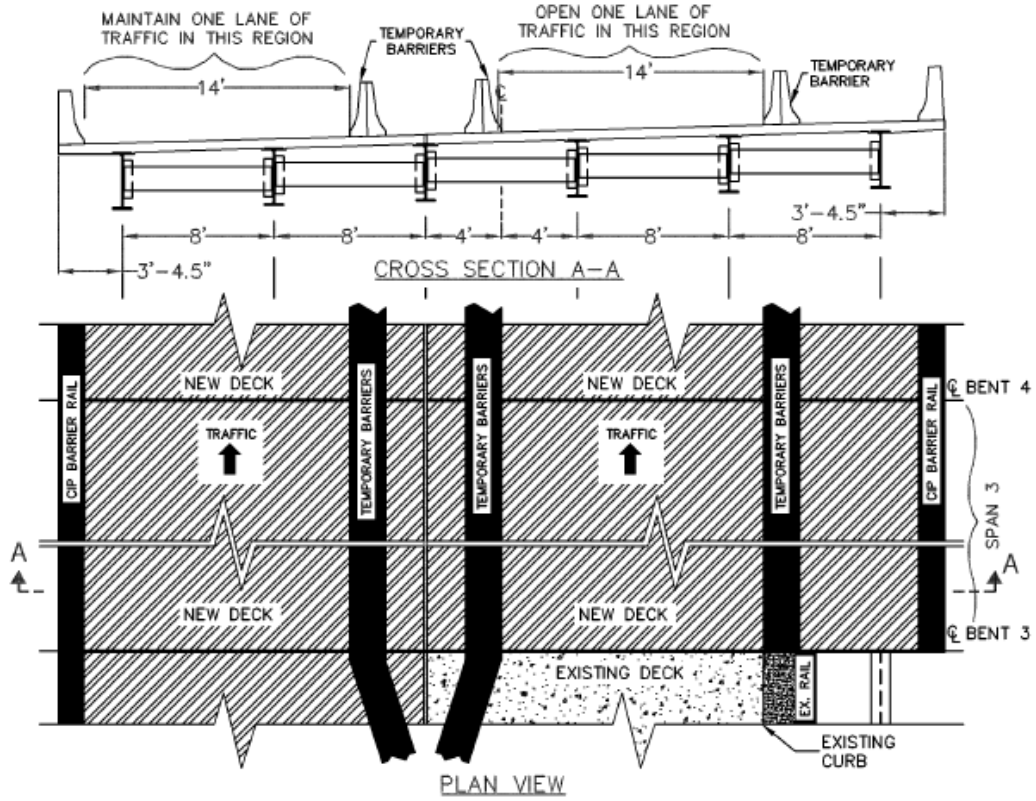

Figure 5.15 Construction Sequence, Stage II - Task 8

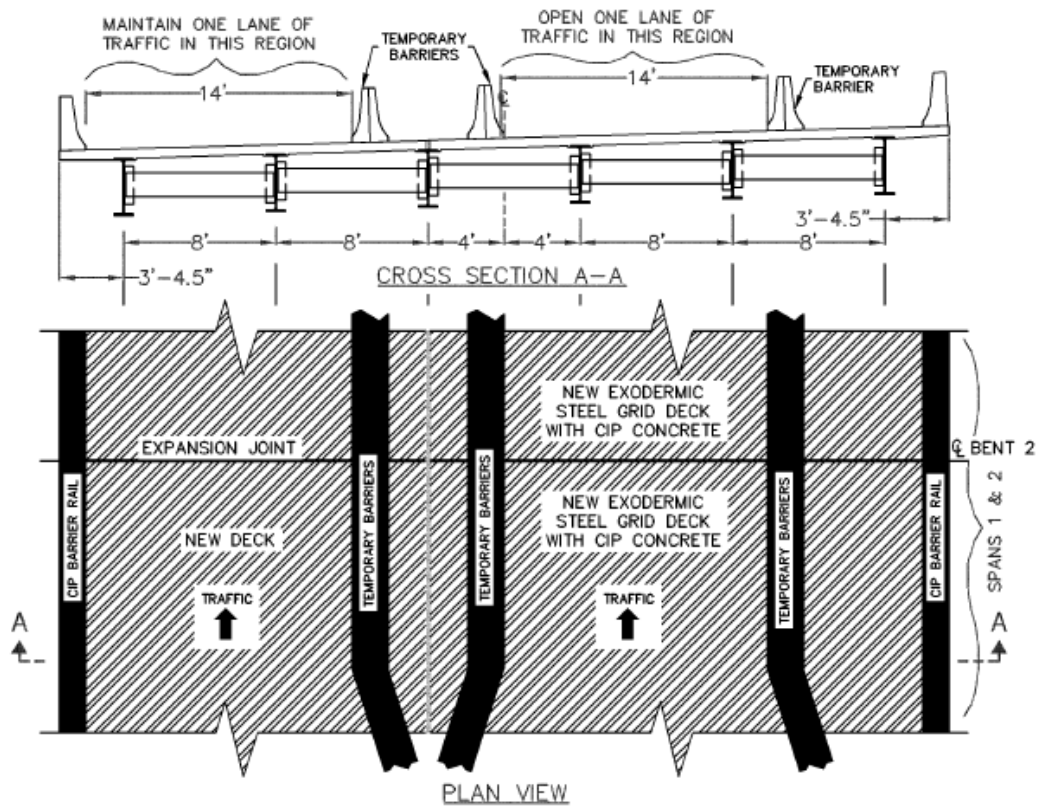

Figure 5.16 Construction Sequence, Stage II - Task 9

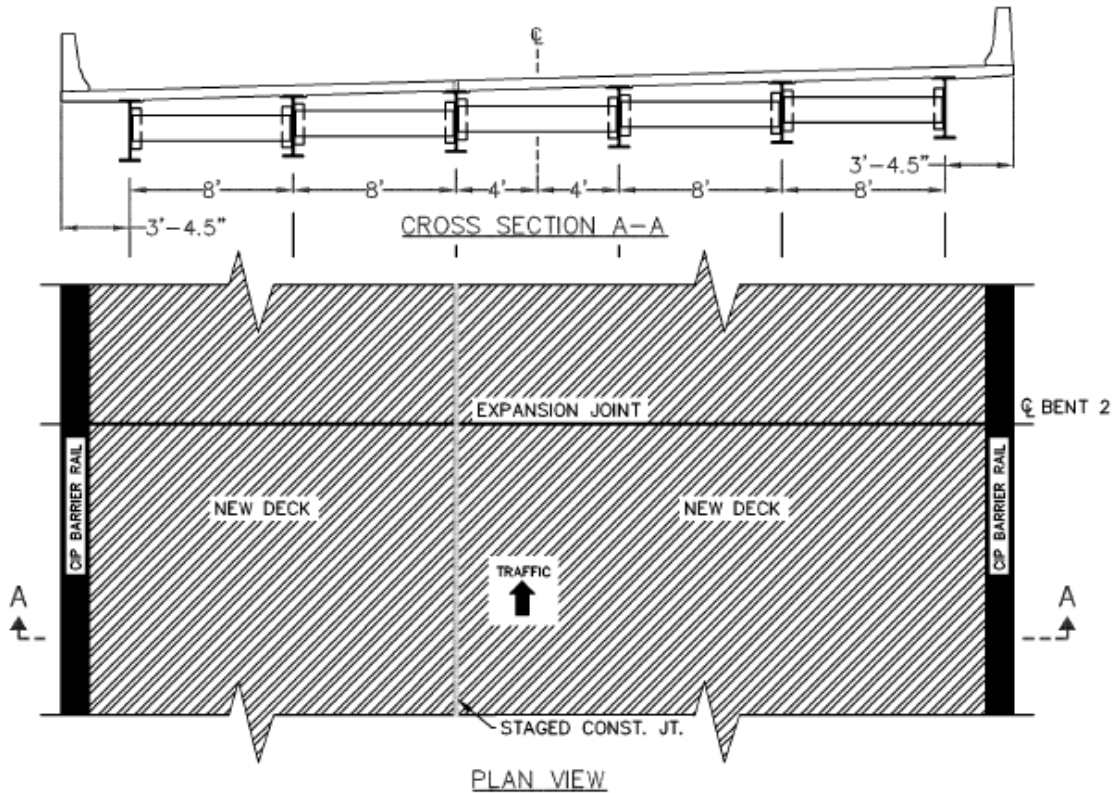

Figure 5.17 Construction Sequence, Stage II - Task 10

5.4. Stage III Construction

The existing deck of the outside lane portion of the southbound bridge is replaced in Stage III. Figures 5.18 through 5.22 show the different tasks to be completed during the Stage III construction. Work during this stage shall progress in the direction of traffic. A description of these tasks and figures are as follows.

The first task is to install new girder lines on the north side of the bridge for all four spans as shown in Figure 5.18. Traffic is maintained in both lanes during this task. Task 2 and 3 is to place temporary barriers for the full length of the bridge and close down traffic to the outside lane as shown in Figure 5.19. Once traffic is closed to the outside lane, the outside lane portion of the deck shall be demolished for the full length of the bridge as shown in Figure 5.20. This is Task 4 of Stage III. Now the new precast

Exodermic deck panels can be installed for the outside lane portion of the bridge in Spans 3 and 4. The cast-in-place barrier rails shall also be installed in Spans 3 and 4. This installation of the new precast Exodermic panels and the barrier rails is Task 5 and is depicted in Figure 5.21. Similarly, the new precast NCHRP full-depth deck panels can be installed for the outside lane portion of the bridge in Spans 1 and 2. The cast-in-place barrier rails shall also be installed in Spans 1 and 2. This installation of the new precast NCHRP full-depth deck panels and the barrier rails is Task 6 and is shown in Figure 5.22. This concludes the Stage III construction.

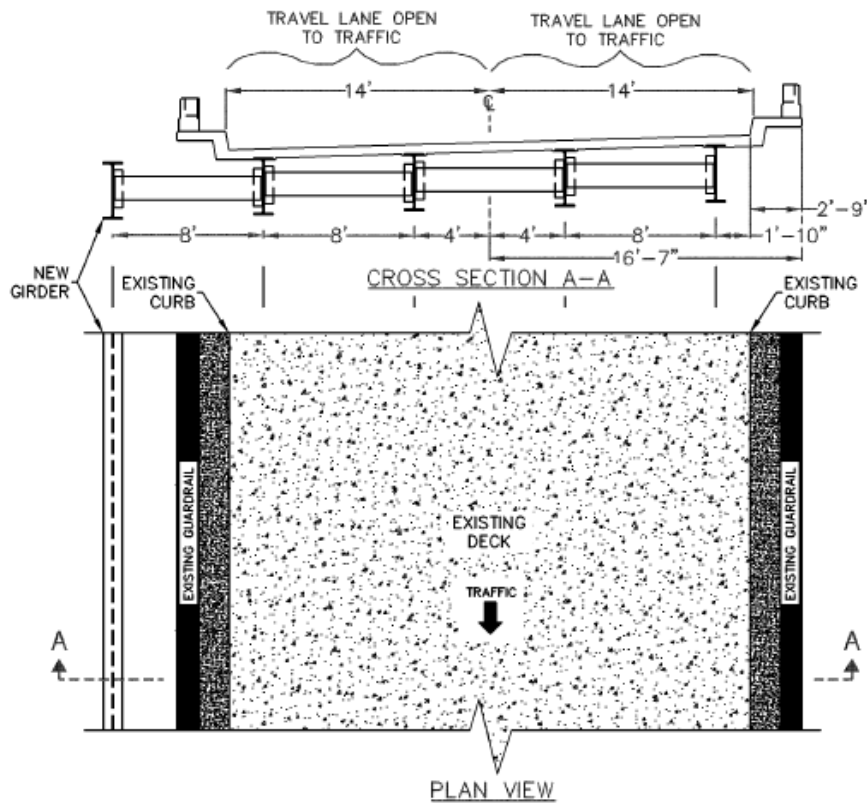

Figure 5.18 Construction Sequence, Stage III - Task 1

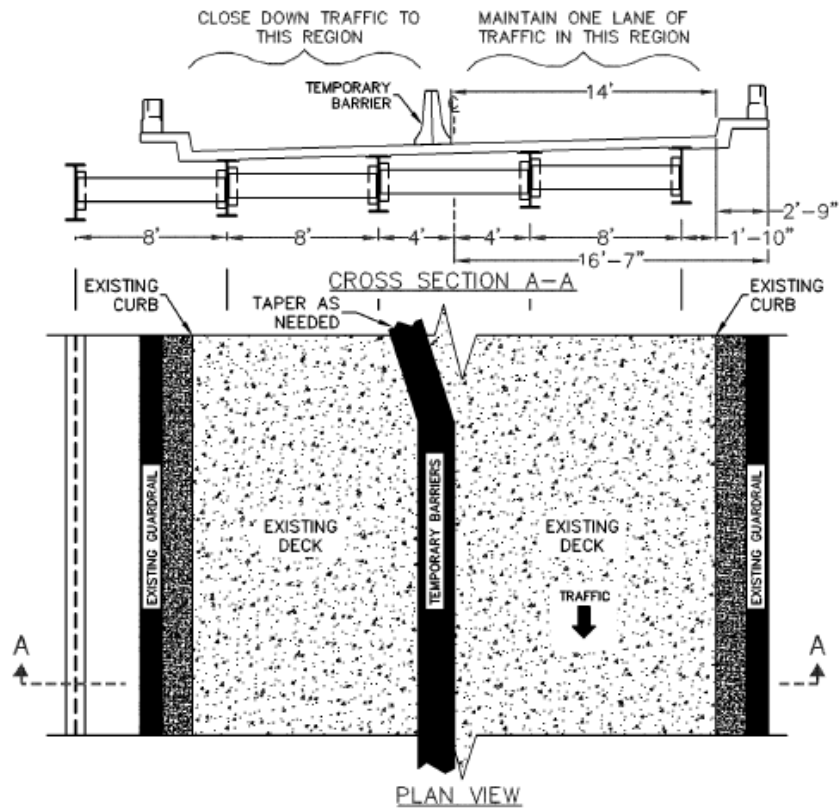

Figure 5.19 Construction Sequence, Stage III - Tasks 2 & 3

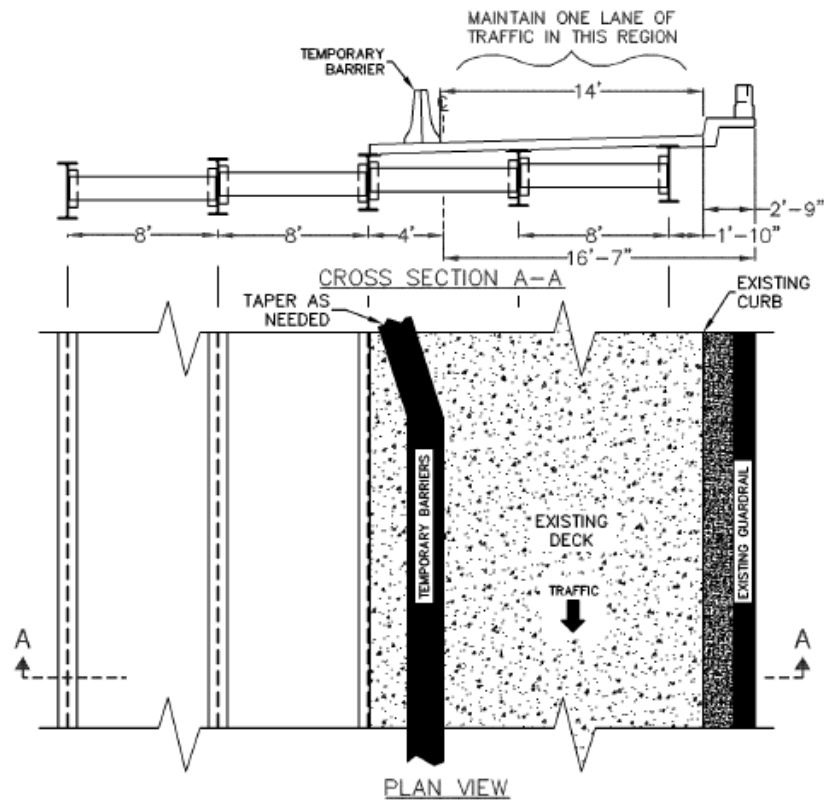

Figure 5.20 Construction Sequence, Stage III - Task 4

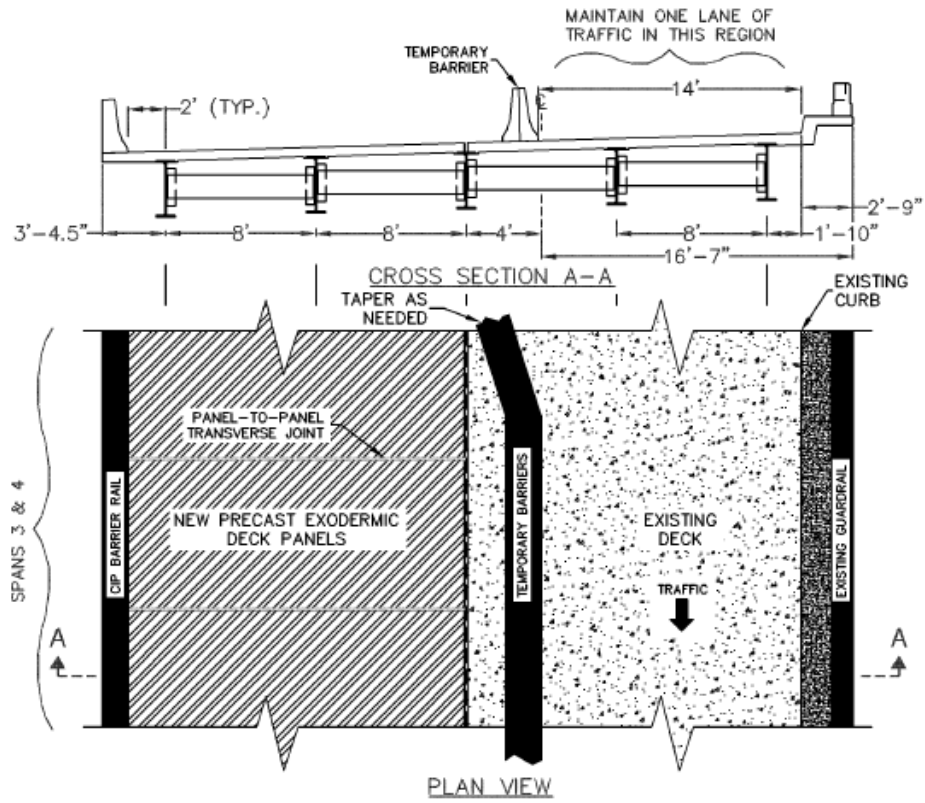

Figure 5.21 Construction Sequence, Stage III - Task 5

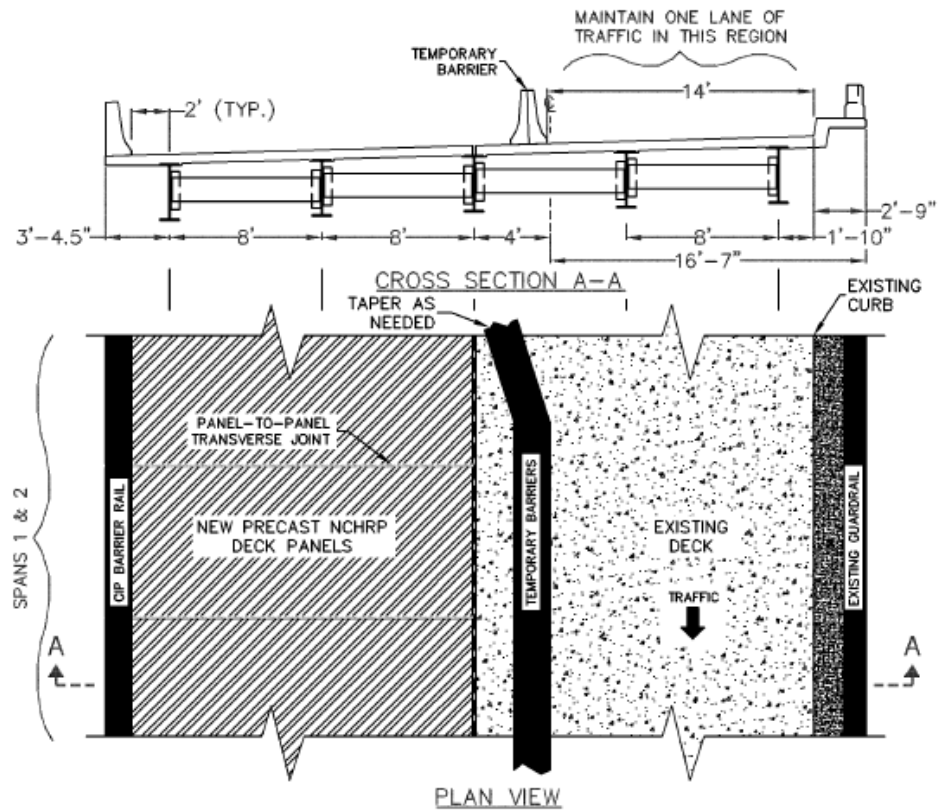

Figure 5.22 Construction Sequence, Stage III - Task 6

5.5. Stage IV Construction

The existing deck of the inside lane portion of the southbound bridge is replaced in Stage IV. Figures 5.23 through 5.36 show the different tasks to be completed during the Stage IV construction. Work for this stage shall progress in the direction opposing traffic. A description of these tasks and figures are as follows.

The first task of Stage IV is to install new girder lines on the south side of the bridge for all four spans as shown in Figure 5.23. Tasks 2 and 3 is to relocate and add temporary barriers to redirect traffic from the inside lane to the outside lane. This will close down traffic to the inside lane so the existing deck can be replaced. This is shown in Figure 5.24. The next task, Task 4, is to demolish as much of the existing deck of the inside lane as can be replaced during the work period as illustrated in Figure 5.25. Task 5 involves installing the new precast NCHRP full-depth deck panels and pouring the staged construction joint where the deck was removed in Task 4. A representation of Task 5 is shown in Figure 5.26. Once the new deck is installed in Task 5, traffic shall be opened up to two lanes. In order to do this, additional temporary barriers are to be added as necessary and equipment is to be removed. This is Task 6 and is shown in Figure 5.27. The next task is to pour the slip-formed cast-in-place barrier rails for the new decking. This is Task 7 and is shown in Figure 5.28. Task 2 through 7 is then repeated each work period until the entire length of Spans 1 and 2 is completed as shown in Figure 5.29. This is Task 8 of Stage IV. Task 9 and 10 is to add and relocate temporary barriers as needed to once again redirect traffic to the outside lane. This will temporarily close down the inside lane as shown in Figure 5.30. Once the traffic is relocated, as much of the existing deck of the inside lane of Spans 3 and 4 as can be replaced for the work period shall be

demolished. This is Task 11 and is shown in Figure 5.31. Task 12 is to install the new precast Exodermic deck panels and pour the staged construction joint where the deck was removed. This is shown in Figure 5.32. After the new deck is installed, temporary barrier rails shall be placed as shown in Figure 5.33 and traffic shall be opened up to each of the two lanes. This is Task 13. The next task is to pour the slip-formed cast-in-place barrier rails for the new decking. This is Task 14 and is shown in Figure 5.34. Task 9 through 14 is then to be repeated for the entire length of Spans 3 and 4. This is Task 15 and is shown in Figure 5.35. After Task 15 is completed, all temporary barriers and equipment is to be removed and traffic is to be opened to two lanes. This is Task 16 and concludes the Stage IV construction. The final view of the northbound bridge is shown in Figure 5.36. The construction on the southbound bridge is now complete.

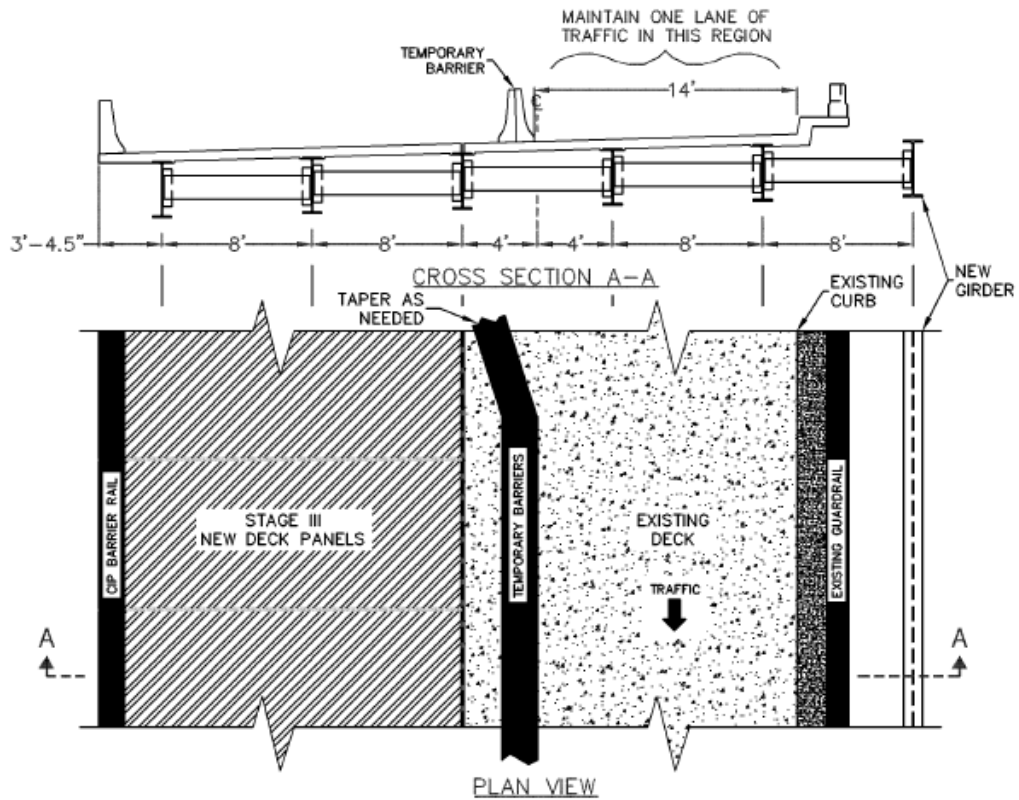

Figure 5.23 Construction Sequence, Stage IV - Task 1

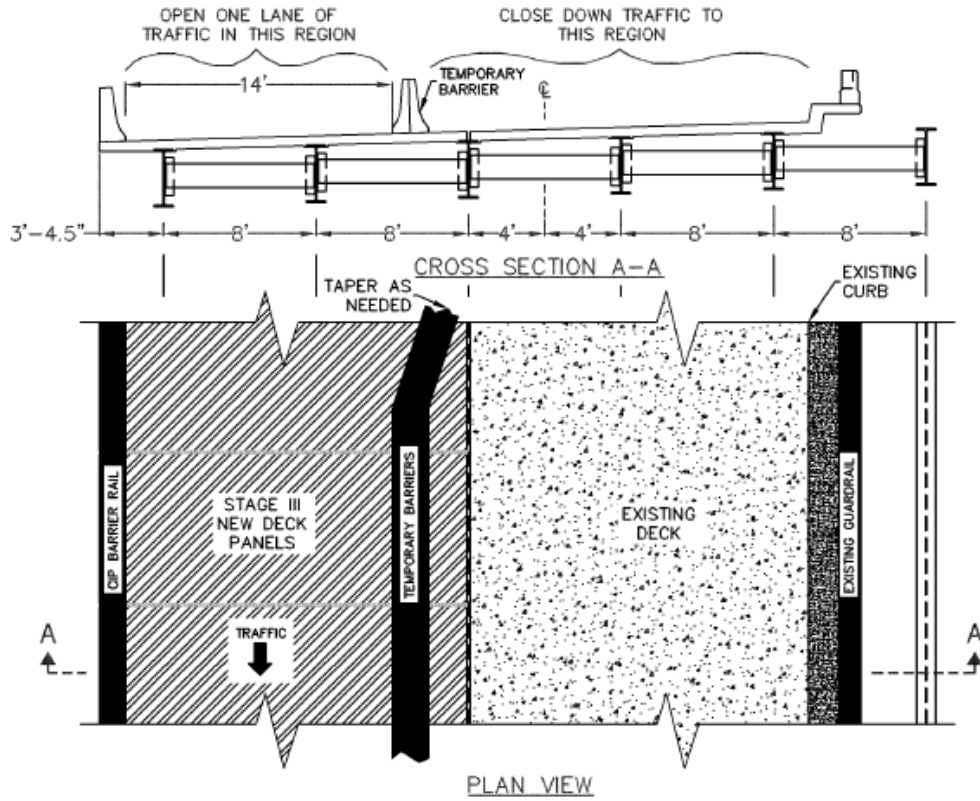

Figure 5.24 Construction Sequence, Stage IV - Tasks 2 & 3

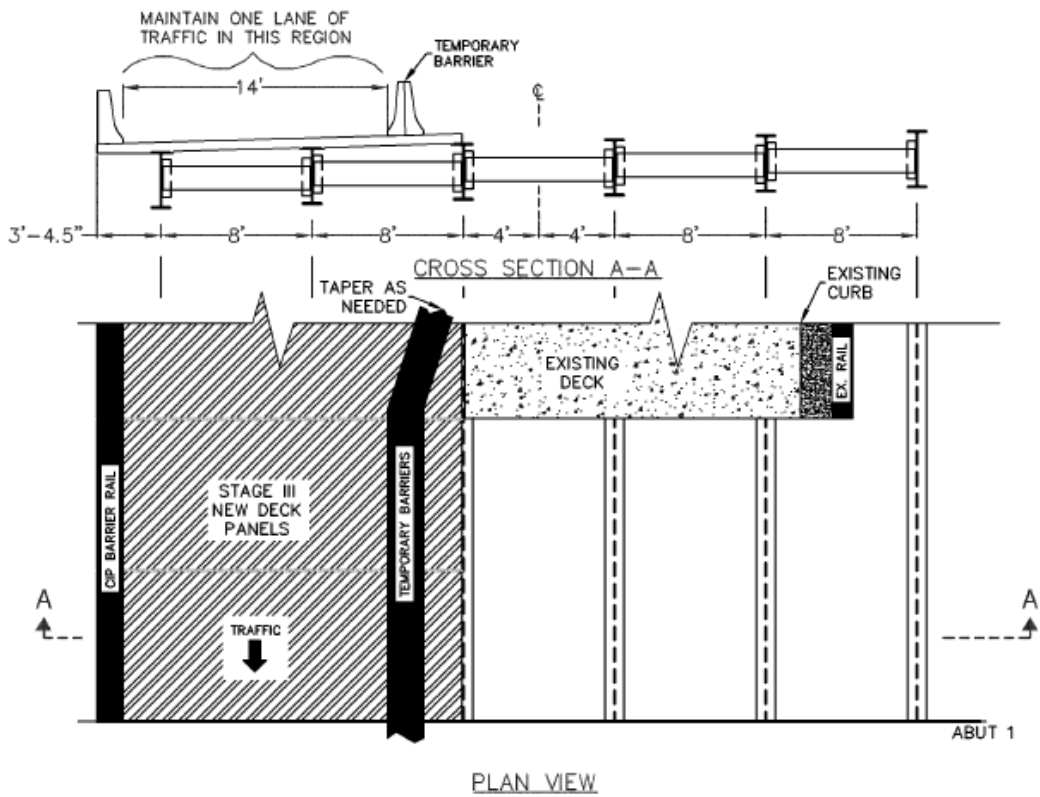
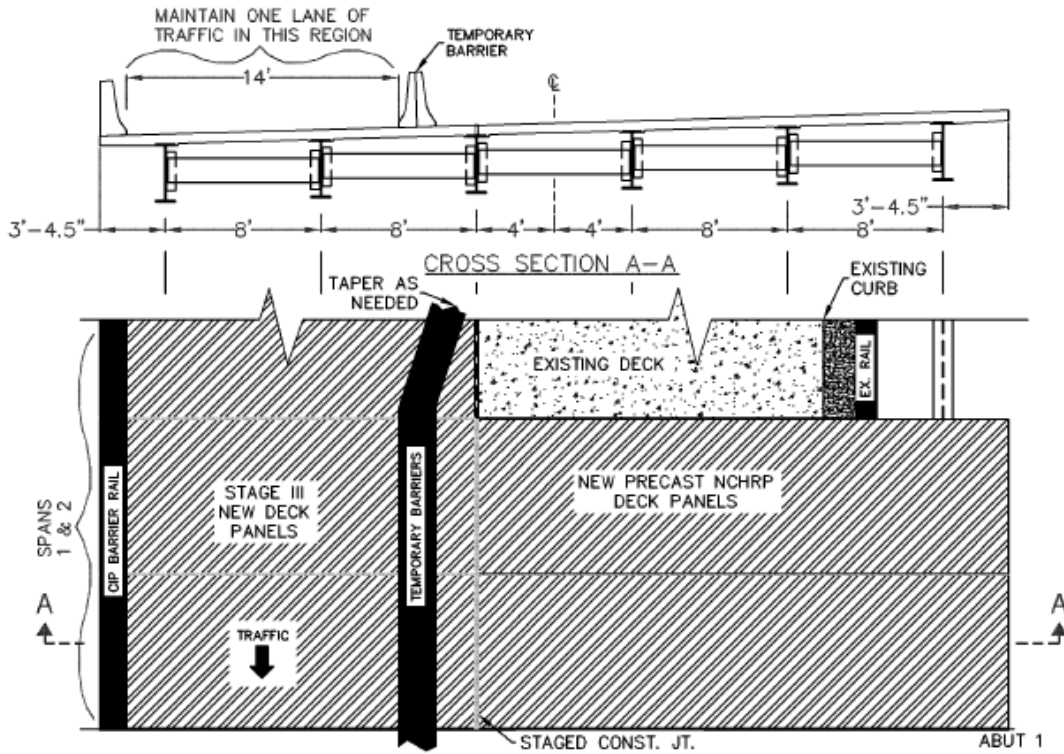
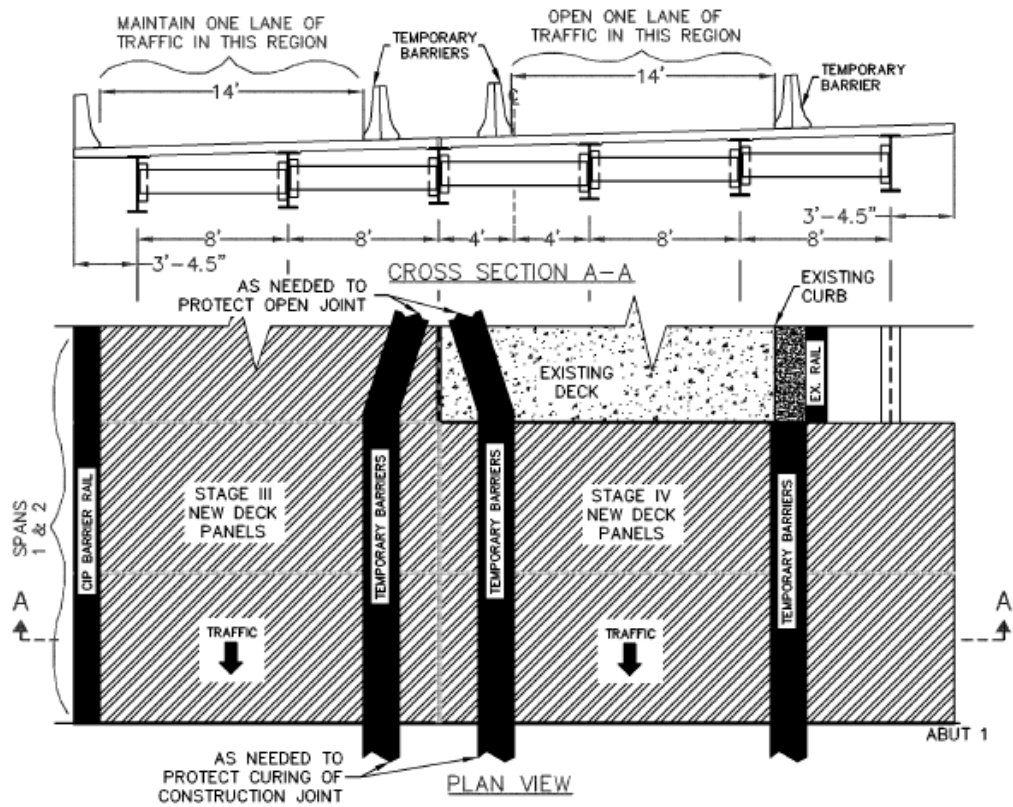

Figure 5.25 Construction Sequence, Stage IV - Task 4



PLAN VIEW

Figure 5.26 Construction Sequence, Stage IV - Task 5



PLAN VIEW

Figure 5.27 Construction Sequence, Stage IV - Task 6

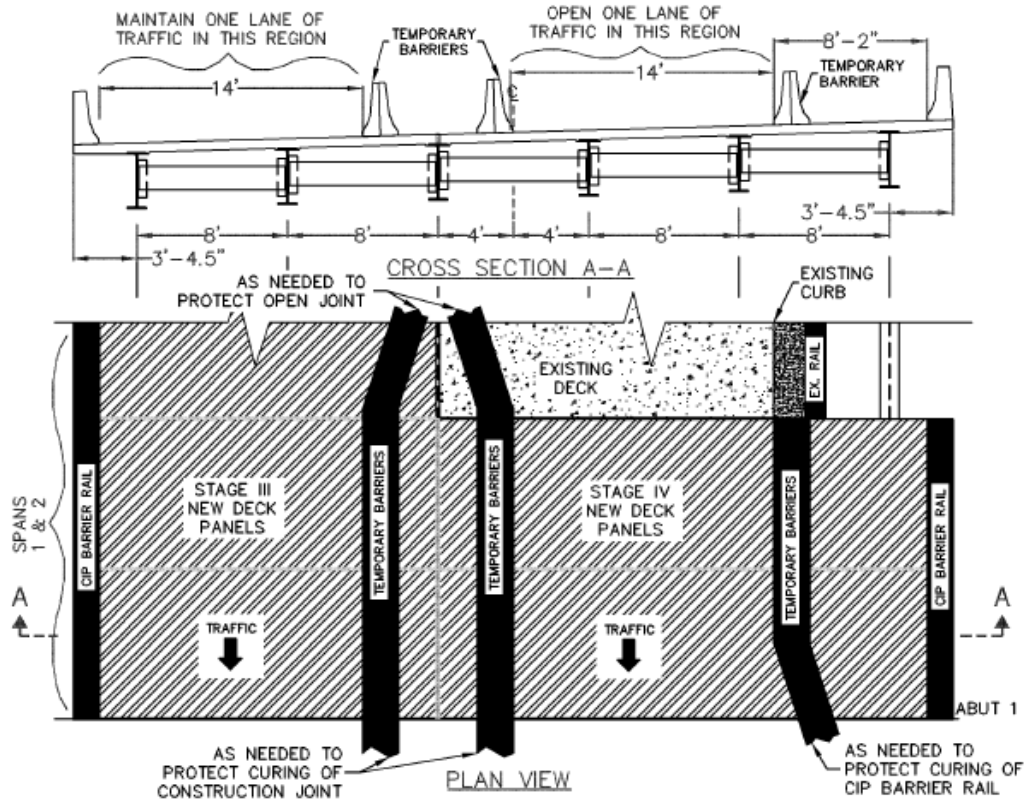

Figure 5.28 Construction Sequence, Stage IV - Task 7

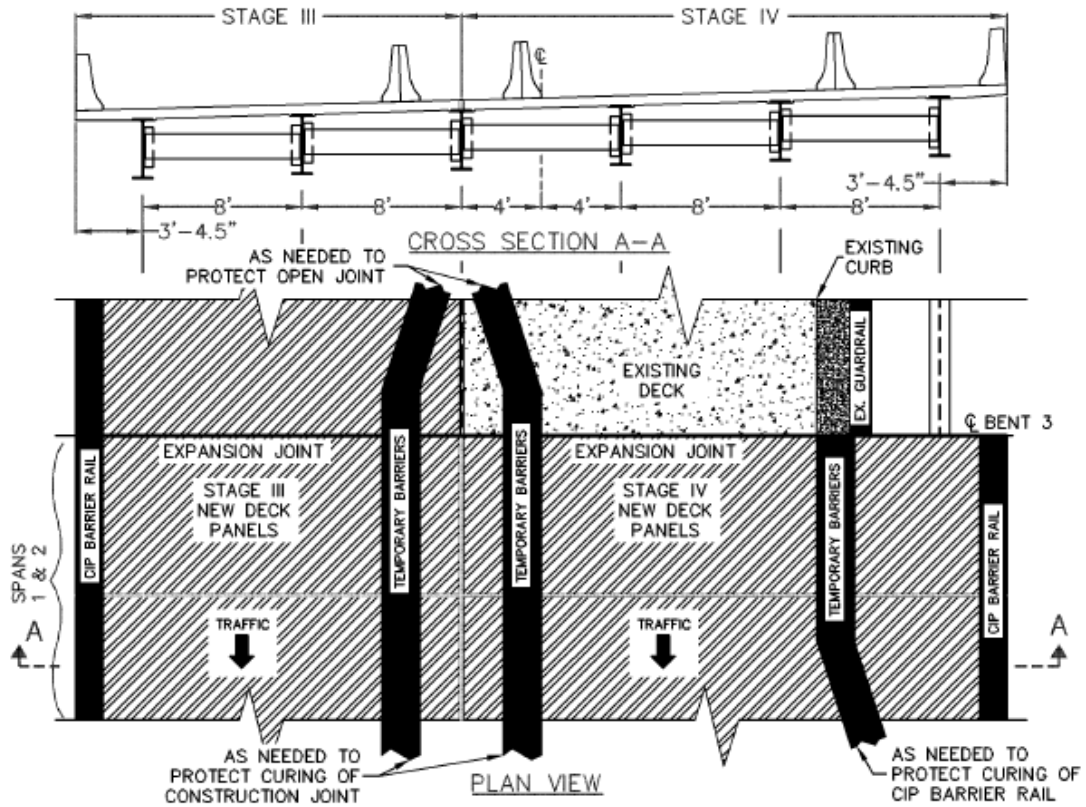

Figure 5.29 Construction Sequence, Stage IV - Task 8

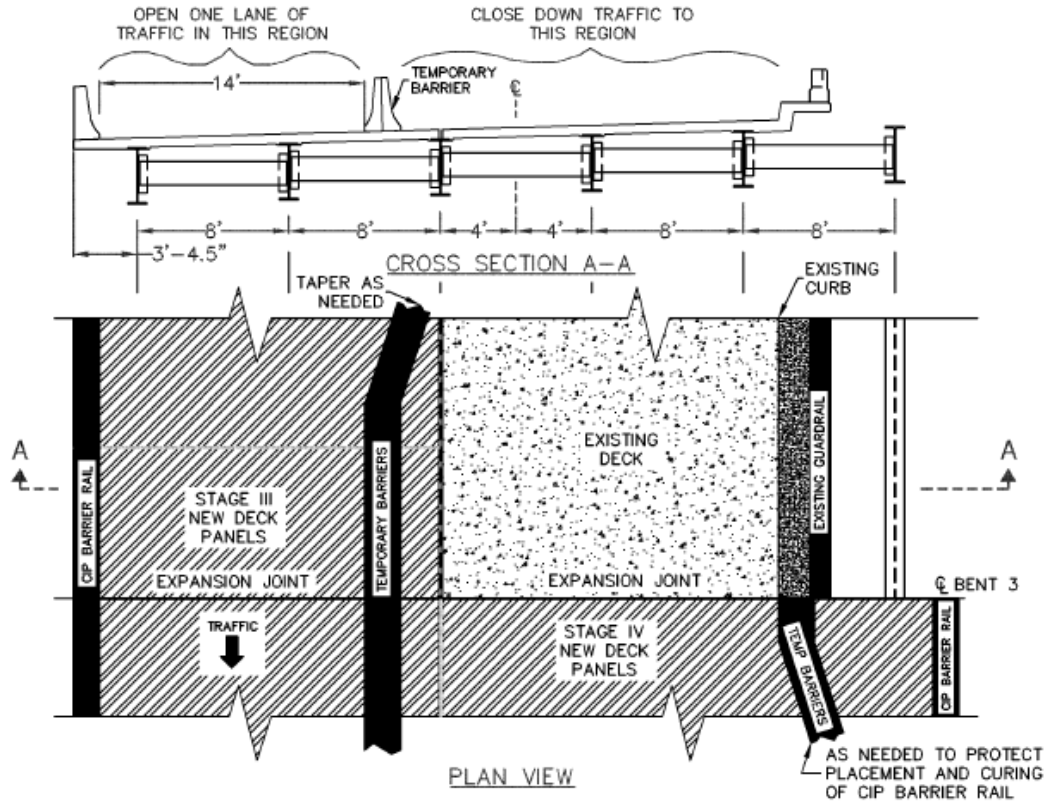

Figure 5.30 Construction Sequence, Stage IV - Tasks 9 & 10

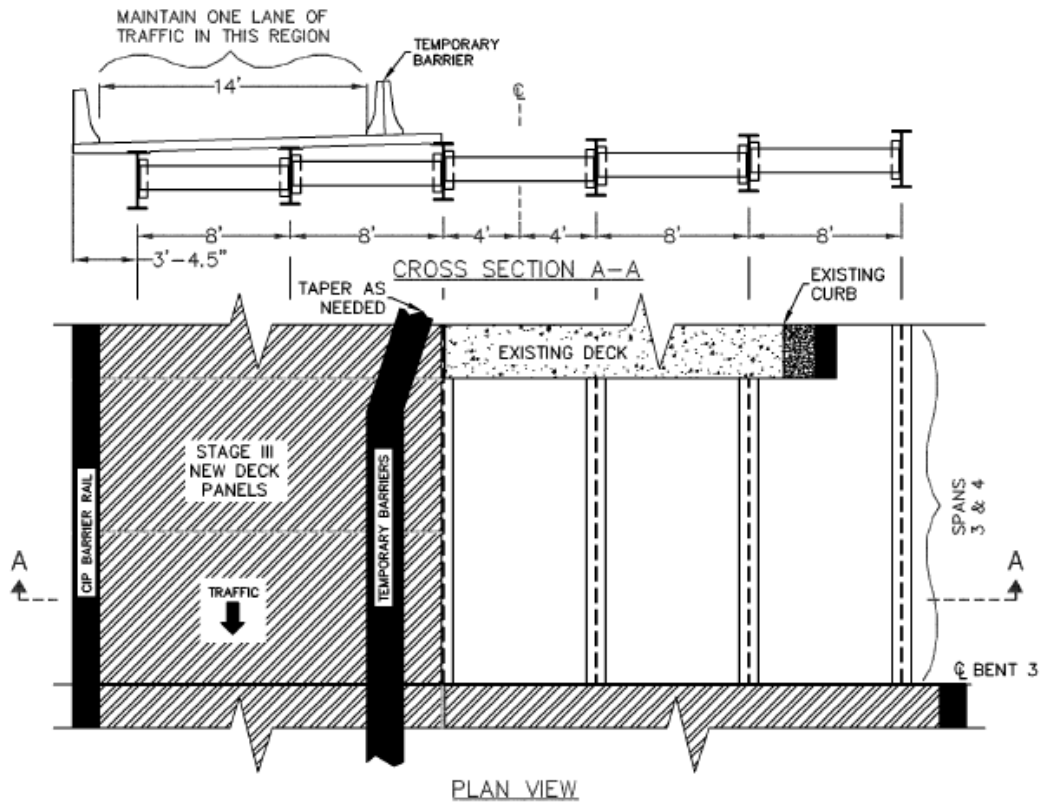

Figure 5.31 Construction Sequence, Stage IV - Task 11

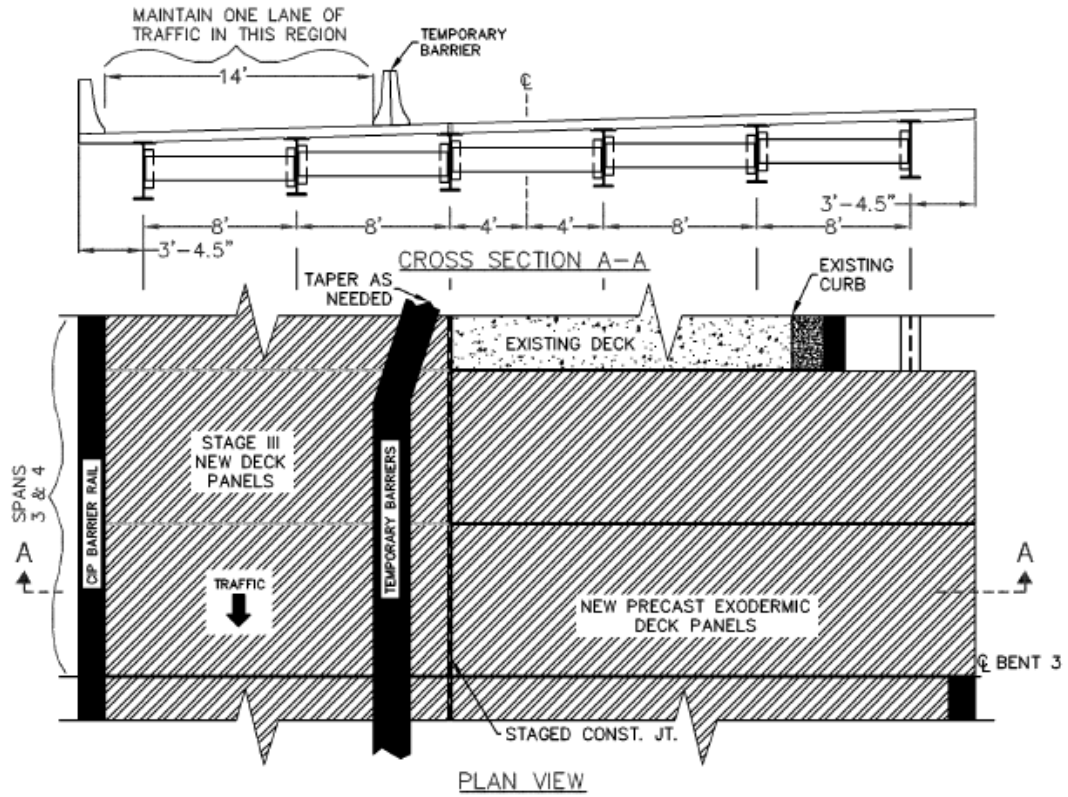

Figure 5.32 Construction Sequence, Stage IV - Task 12

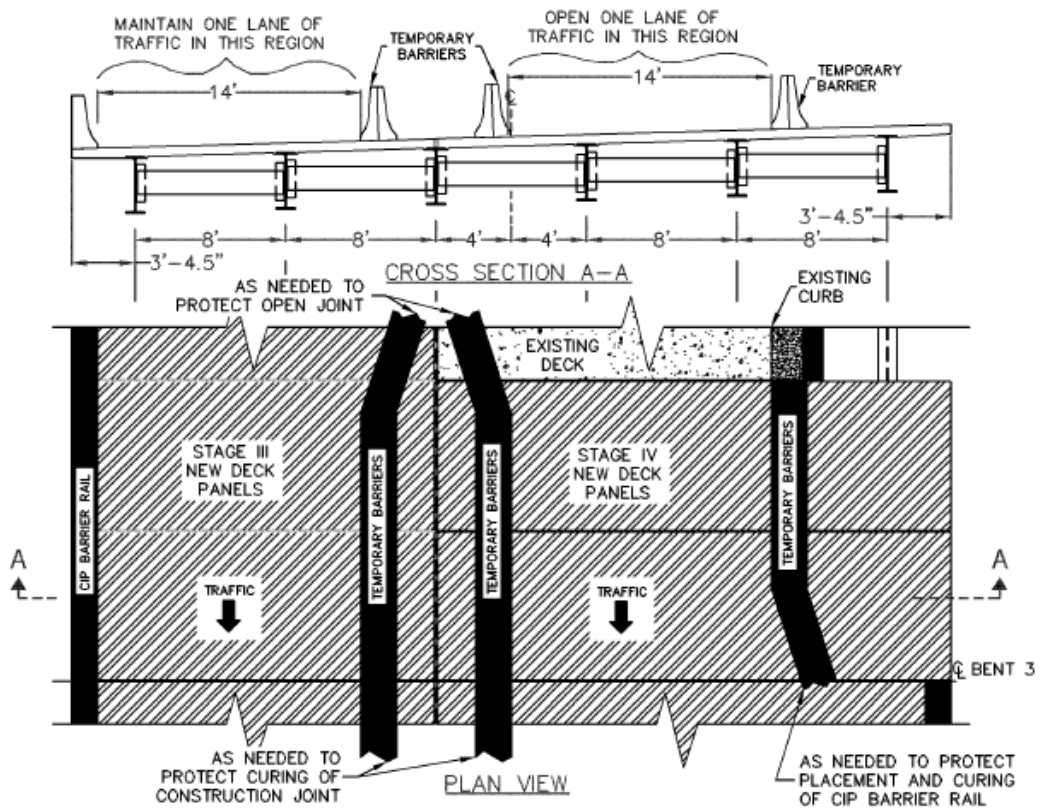

Figure 5.33 Construction Sequence, Stage IV - Task 13

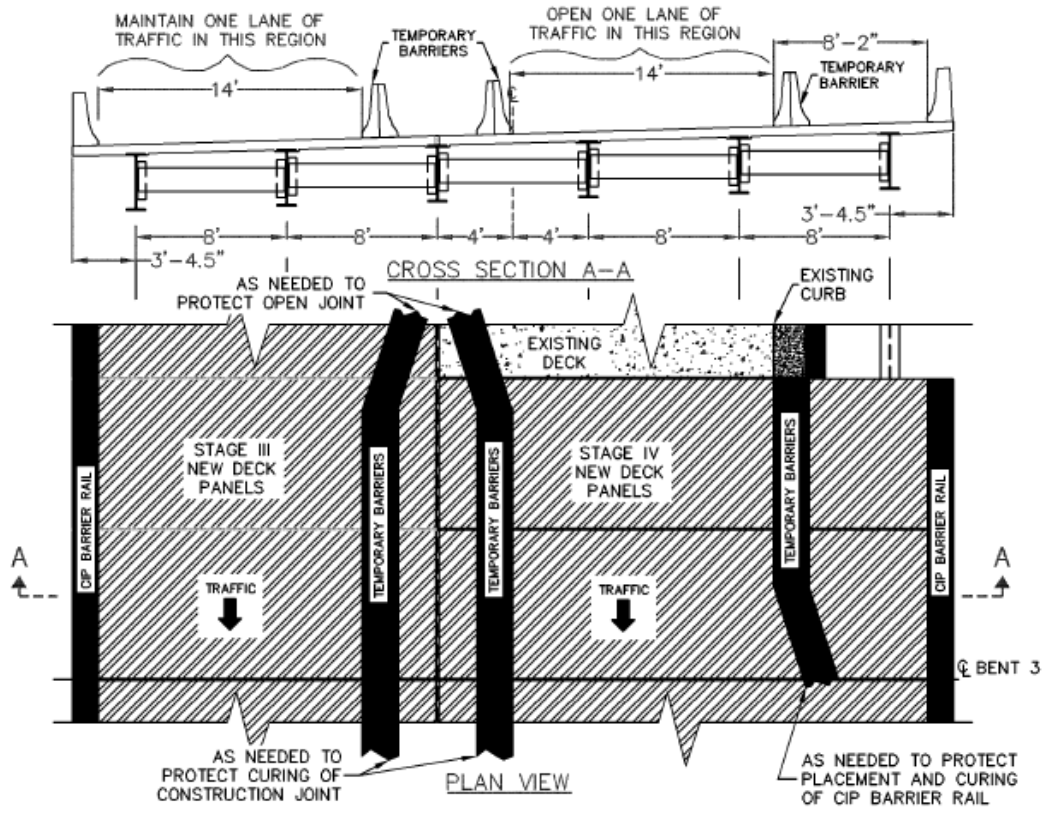

Figure 5.34 Construction Sequence, Stage IV - Task 14

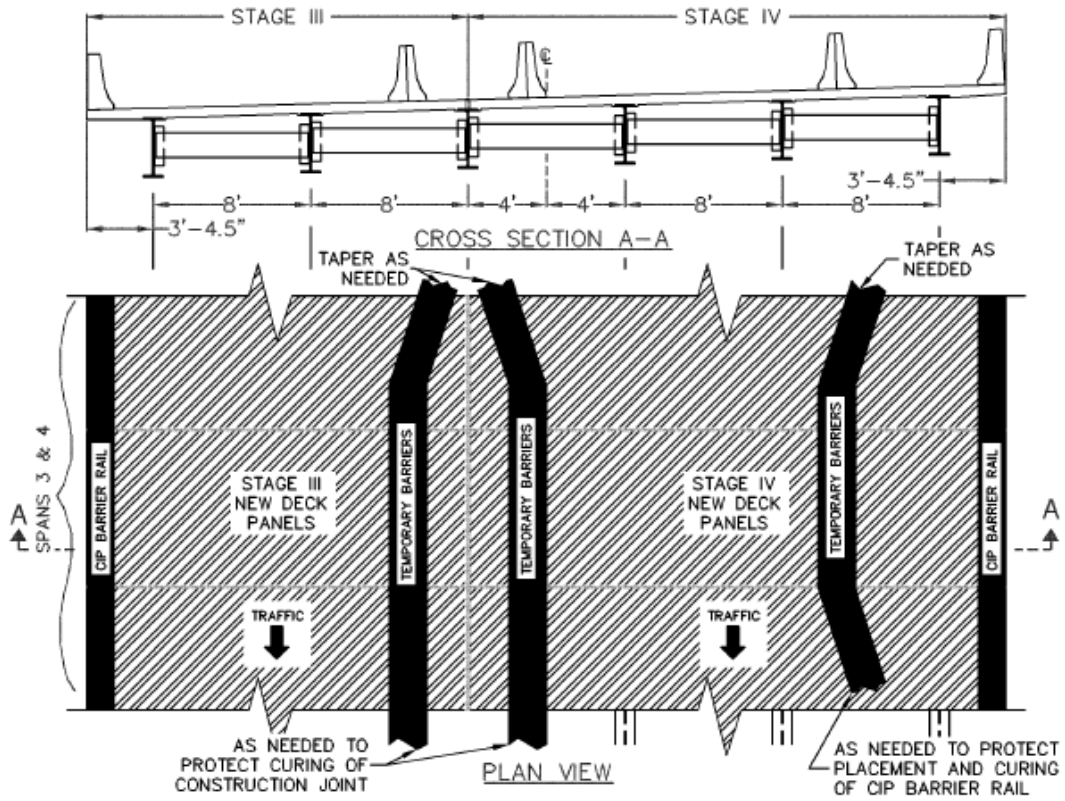

Figure 5.35 Construction Sequence, Stage IV - Task 15

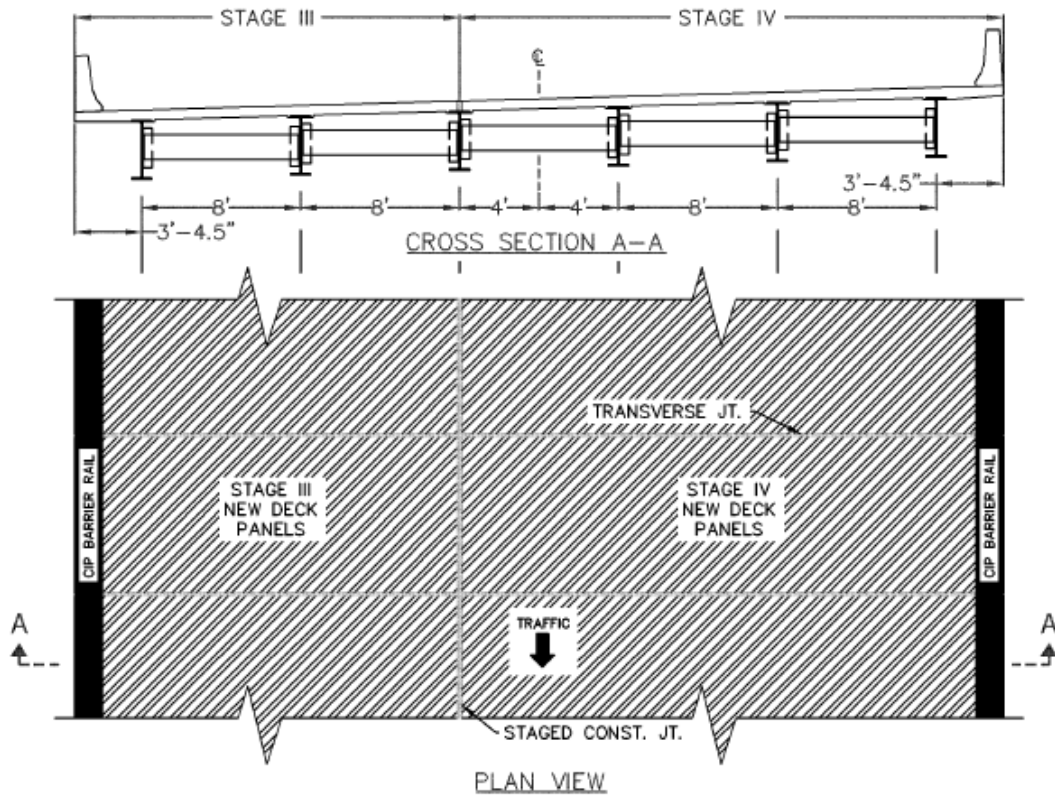

Figure 5.36 Construction Sequence, Stage IV - Task 16

5.6. Remarks

The precast systems were chosen to be on the southbound bridge since the southbound bridge is subjected to heavier truck traffic than the northbound bridge. This will provide better testing results for the precast systems. Better testing of the precast systems is desired since precast systems are less commonly used than cast-in-place systems.

The construction for the precast systems is more time constrained than the construction for the cast-in-place systems. The construction for the precast systems is to be completed overnight during off peak hours while the construction for the cast-in-place systems are to be completed over weekend work periods. However, the contractor may work whenever desired on the first pass of each of the bridges, Stages I and III. Since the

construction for the precast systems is more time constrained, the cast-in-place systems were chosen to be installed first to allow the contractor to get experience in the demolition process prior to working on the precast systems. This will provide for a more accurate comparison of the four deck systems.

The Exodermic precast system was chosen to be installed prior to the NCHRP full-depth deck system because Exodermic systems have been around longer and therefore more information and experience pertaining to them is available. This will provide the contractor with experience in the construction process prior to work on the NCHRP full-depth deck system.

It was chosen to install the new girder lines prior to the demolition of the existing deck to provide a better understanding of the time required for the deck replacement process. This is to be done whenever feasible.

Work was chosen to progress in opposition to traffic to minimize the use of temporary barriers and allow the usage of existing deck and barrier rails. However, since work during the first pass, Stages I and III, is independent of traffic patterns, work was chosen to be completed in the direction of traffic to minimize the moving of work equipment. This is beneficial because all of the equipment will be at the correct end of the bridge at the end of the first pass.

5.7. Comparison to ALDOT's Accepted Sequence of Construction

The Alabama Department of Transportation (ALDOT) has now finalized a sequence of construction that is similar to the initial proposed sequence of construction in this report. ALDOT's construction sequence differs slightly by incorporating additional steps

and by using a different traffic pattern for the southbound bridge. The temporary barrier rails that are to be used are also different.

A step was added at the beginning of the construction sequence for Stages I and III. This step diverts traffic into one lane in the center of each bridge to provide room for the expansion of the bridge end slabs and substructures. The expansion of the end slabs and substructures is necessary for the widening of the bridge deck, which requires the addition of a girder on both sides of each bridge. This step should not affect the results from this study. However, verification of this is out of the scope of this report.

ALDOT's change in traffic pattern for the southbound bridge mirrors that of the traffic pattern for the proposed sequence of construction. That is, Stage III of the proposed sequence of construction is Stage IV of ALDOT's sequence of construction and Stage IV of the proposed sequence of construction is Stage III of ALDOT's sequence of construction. This has no impact on the results from this report.

ALDOT's temporary barrier rails differ from the ones proposed in this study. The effect this has on the results from this report is unknown and out of the scope of this study. Further investigation may be required.

It should be noted that some special provisions must be made to the Alabama Standard Construction Specifications in order to implement the rapid deck replacements on the sister I-59 bridges at Collinsville, AL. A first draft of the Special Provisions required is provided in Appendix C.

6. Design of Deck Elements

6.1. General

Preliminary designs for each of the deck systems considered in this study were checked and modified in accordance to the AASHTO LRFD Bridge Design Specifications (AASHTO 2008). The checking procedure and sequence for each of the systems were the same and are described in the subsections below.

6.1.1. Load Calculations

As per AASHTO specifications, the following loads were considered for the design of the deck systems: DC, LL, IM, WL, & CT. DC is the dead load effects produced by the weight of the deck and barrier rails. LL is the static vehicular live load. IM is the dynamic load allowance factor used to increase the static vehicular live load to accommodate for dynamic effects. WL is the wind pressure on vehicles. CT is the design force associated with a vehicular collision with a barrier rail. This force is used to design the overhang portion of the deck. The values of each of these loads were determined in accordance to Section 3 of the 4th Edition of the AASHTO LRFD Bridge Design Specifications with the 2008 interim (AASHTO 2008).

Several different bridge deck cross-sections and load conditions exist throughout the construction process. All of these load cases were considered. Each load case is defined in Tables 6.1 & 6.2 for the cast-in-place and precast concrete deck systems respectively. For these tables, the Roman numeral is the construction stage and the following number is the step within the stage. Construction Stages I and II are for the cast-in-place deck (NBR Bridge) and Stages III and IV are for the precast deck (SBR Bridge). Figures 6.1

and 6.2 show the deck cross-sections that correspond to each of the load cases indicated in Tables 6.1 and 6.2, respectively. Although the final load case will generally be the worst, there are a few locations along the cross-section where other load cases control. The maximum values at specific locations will be needed to design certain components of the decking system. Some of the loads listed in Tables 6.1 & 6.2 will only act on parts of the cross-section due to lack of continuity at the longitudinal construction joint. Figures 6.3 and 6.4 illustrate the regions in which the loads act for the cast-in-place and precast concrete systems, respectively.

Table 6.1 Cast-in-Place Deck System Load Cases

Load Case #	Stage	Load Case	Loads		
			DL	LL, WL	Barriers
1	I.4	Only Case	Stage I		
2	I.6	Only Case	Stage I		B1
3	II.2&3	Before I L.L.	Stage I		B1, B2
4	II.2&3	After I L.L.	Stage I	Stage I	B1, B2
5	II.5	Only Case	Stages I, II	Stage I	B1, B2
6	II.6	Only Case	Stages I, II	Stage I	B1, B2, B3, B4
7	II.7	Only Case	Stages I, II	Stages I, II	B1, B2, B3, B4
8	II.8	Only Case	Stages I, II	Stages I, II	B1, B2, B3, B4, B5
9	Final	Only Case	Stages I, II	Final	B1, B5

Table 6.2 Precast Deck System Load Cases

Load Case #	Stage	Load Case	Loads		
			DL	LL, WL	Barriers
1	III.5	Before B1	Stage III		
2	III.5	After B1	Stage III		B1
3	IV.2&3	Before III L.L.	Stage III		B1, B2
4	IV.2&3	After III L.L.	Stage III	Stage III	B1, B2
5	IV.5	Only Case	Stages III, IV	Stage III	B1, B2
6	IV.6	Before IV L.L. IF B3 1st	Stages III, IV	Stage III	B1, B2, B3
7	IV.6	Before IV L.L. If B4 1st	Stages III, IV	Stage III	B1, B2, B4
8	IV.6	Before IV L.L.	Stages III, IV	Stage III	B1, B2, B3, B4
9	IV.6	After IV. L.L.	Stages III, IV	Stages III, IV	B1, B2, B3, B4
10	IV.7	Only Case	Stages III, IV	Stages III, IV	B1, B2, B3, B4, B5
11	Final	Only Case	Stages III, IV	Final	B1, B5

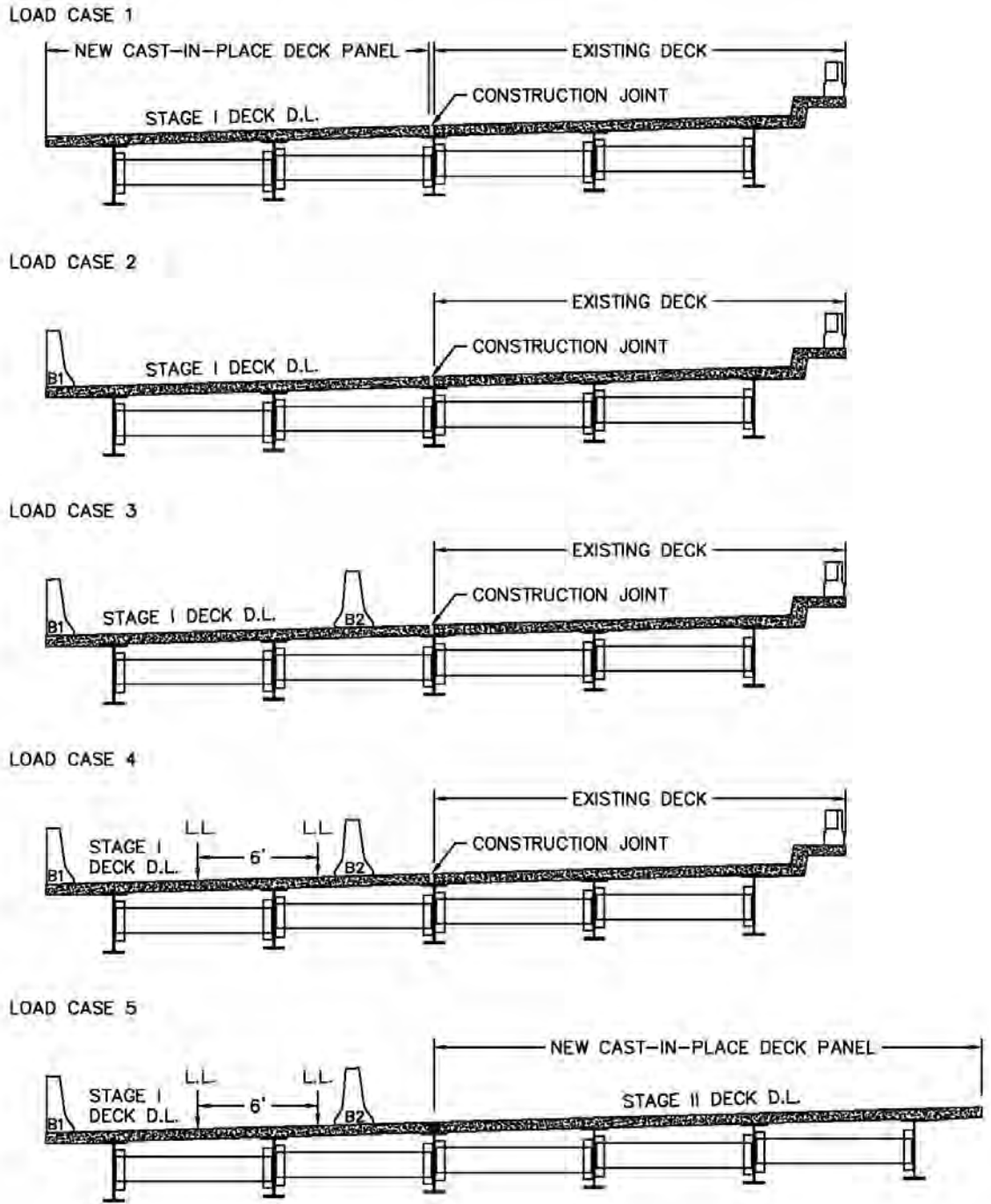
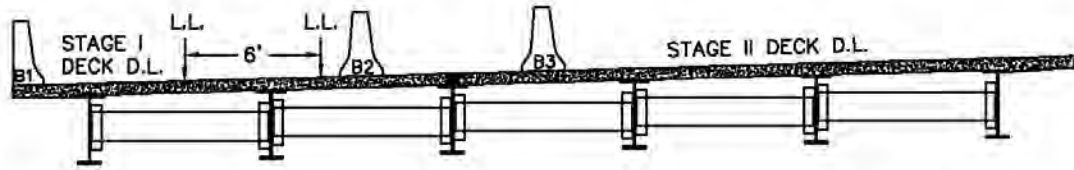
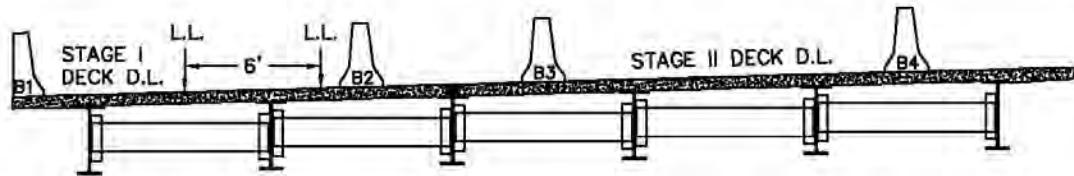

Figure 6.1 Cast-in-Place Deck System Load Cases

LOAD CASE 6



LOAD CASE 7



LOAD CASE 8

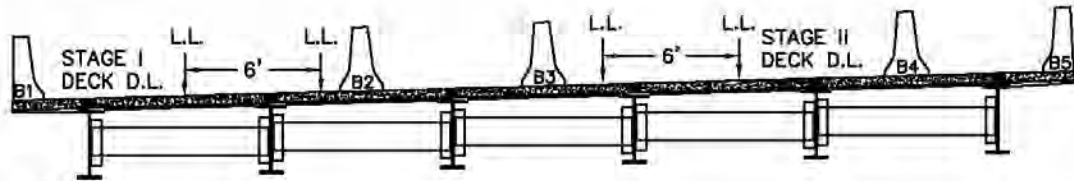

LOAD CASE 9 (FINAL)

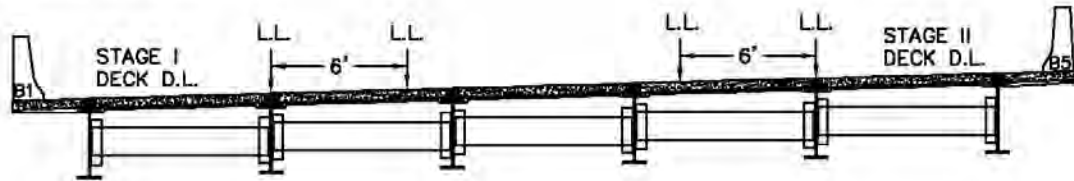

Figure 6.2 Cast-in-Place Deck System Load Cases (Continued)

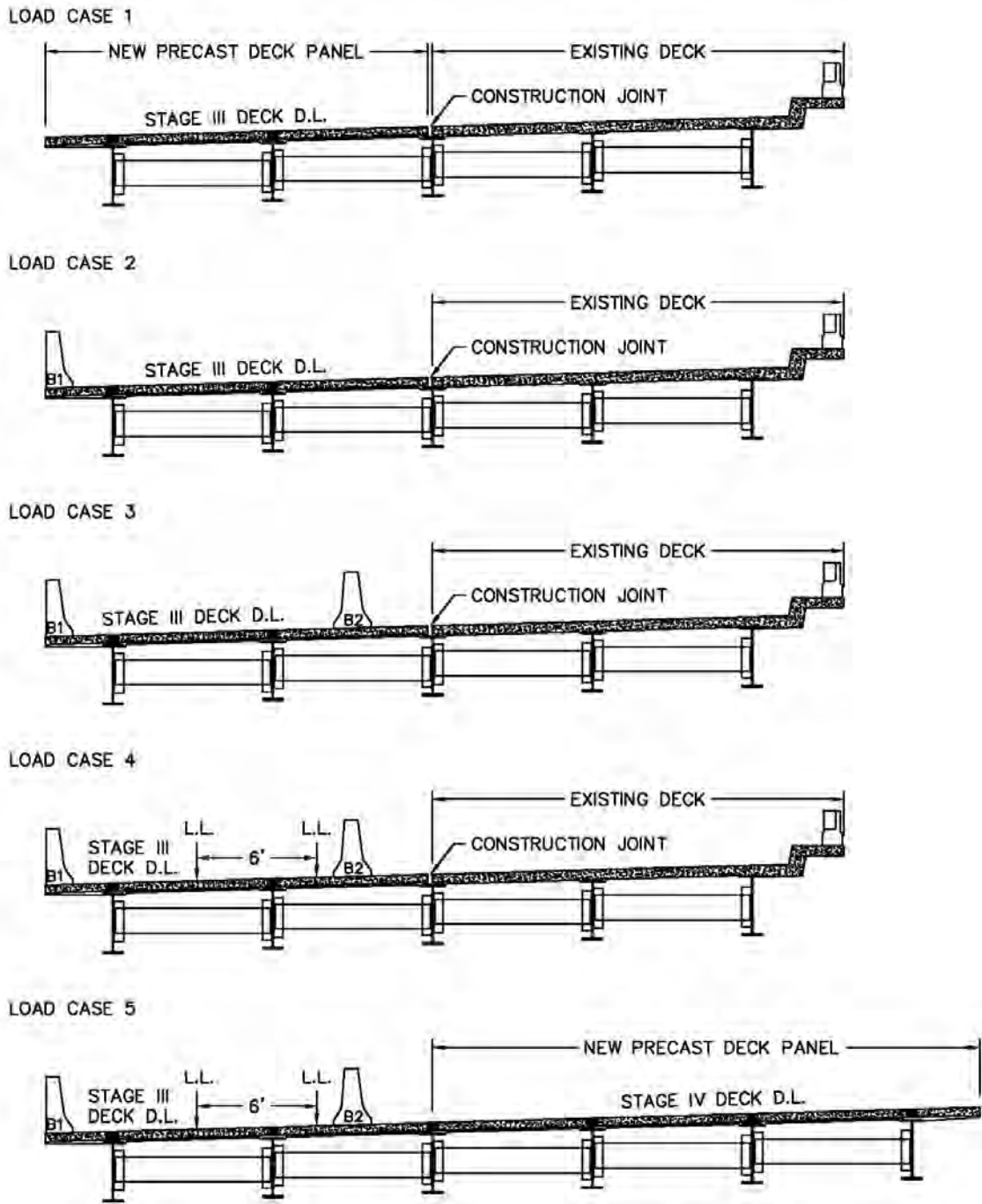
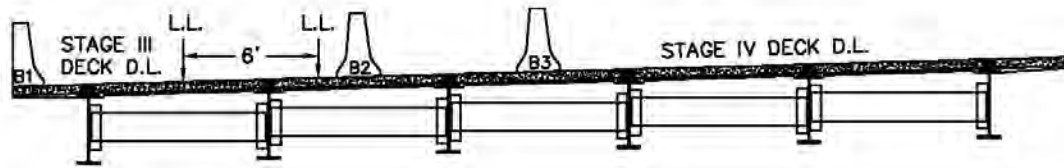
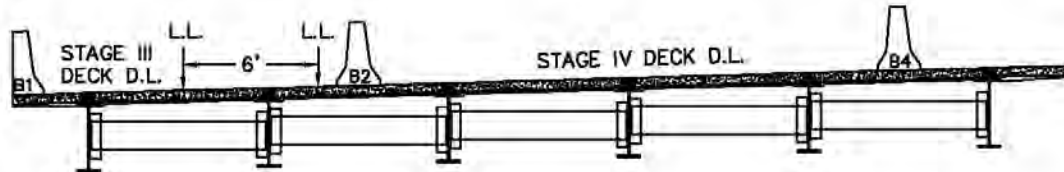

Figure 6.3 Precast Deck System Load Cases

LOAD CASE 6



LOAD CASE 7



LOAD CASE 8

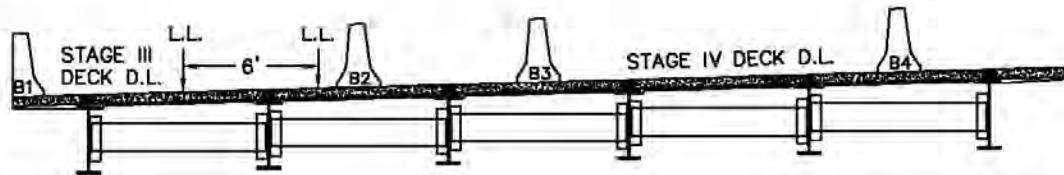

LOAD CASE 9

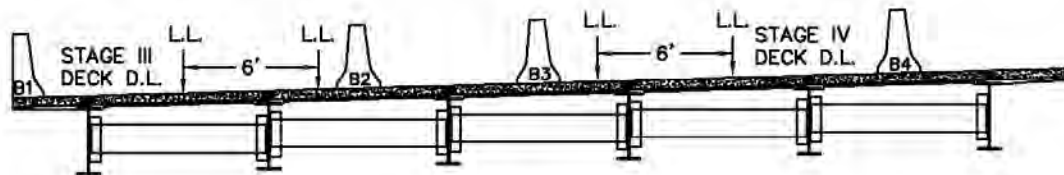

LOAD CASE 10

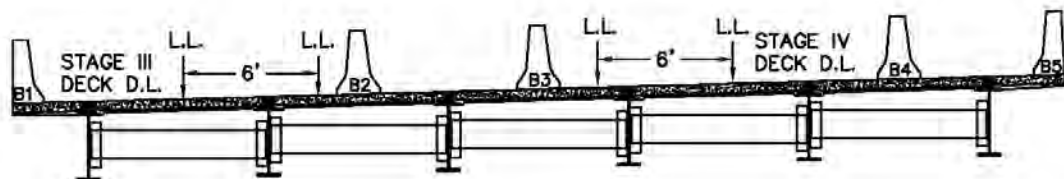

LOAD CASE 11 (FINAL)

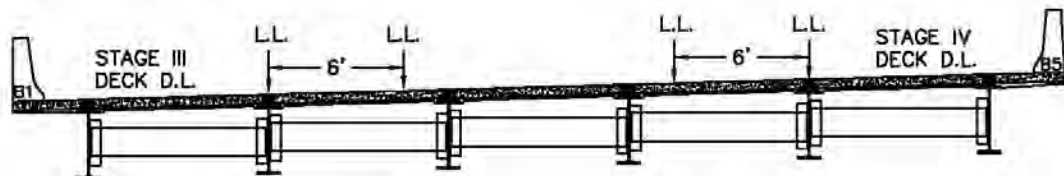

Figure 6.4 Precast Deck System Load Cases (Continued)

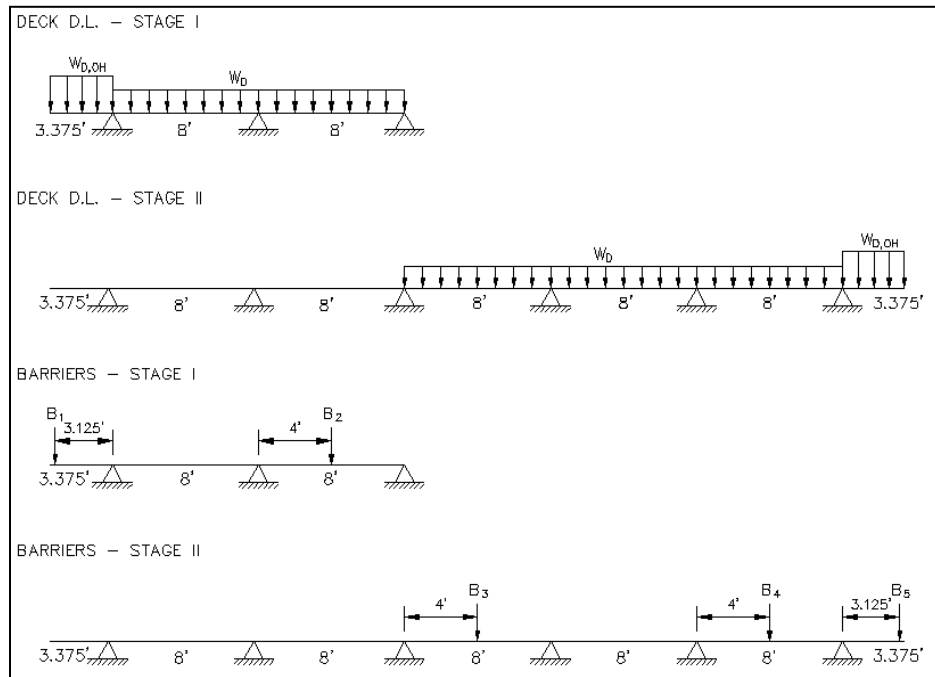

Figure 6.5 Cast-in-Place Deck System Loading Regions

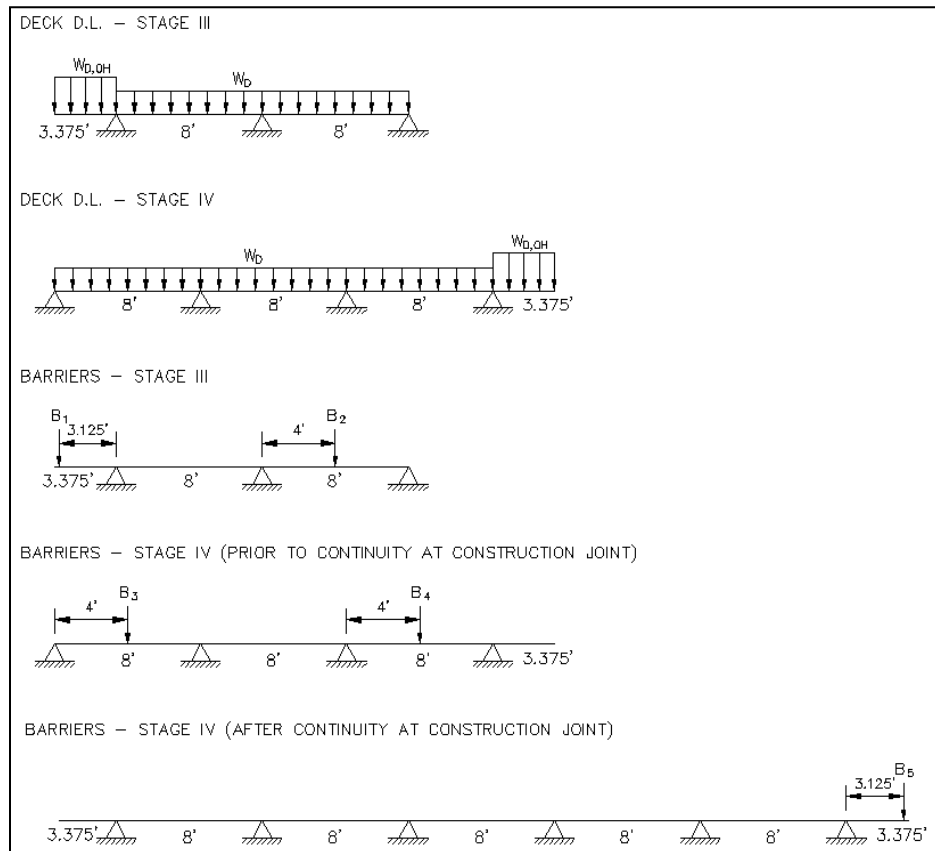

Figure 6.6 Precast Deck System Loading Regions

All of the load components were calculated independently. This simplifies the determination of each of the load cases since there are several variations in barrier and live load locations. Each component that applies to the load case being considered is simply superimposed with all of the other applicable components.

The dead load values (DC) were conservatively estimated for each of the deck systems and the barrier rails. The dead load of the deck overhang was calculated separately from the rest of the deck because the deck overhang is generally thicker than the rest of the deck causing it to weigh more. This additional thickness is required to resist loads transferred from a vehicle collision with a barrier rail. The dead load values were determined per foot of deck in the longitudinal direction.

The live load force effects for the grid systems must be determined in accordance with Article 4.6.2.1.8 of the AASHTO Bridge Specifications (AASHTO 2008). The equations of this section are based on orthotropic plate theory and take into account relevant factored load combinations, dynamic load allowance factors, multiple presence factors, and load positioning to produce worst load effects as explained in Article C4.6.2.1.8 of the AASHTO Bridge Specifications (AASHTO 2008). The flexural rigidities used for these equations were determined using cracked transformed section properties. The largest flexural rigidity was used to compute the live load effects because this conservatively determines the worst-case load effect.

Minimum and maximum vehicular live load values (LL) for reinforced concrete deck systems were determined using SAP2000 V14. A test cross-section was used to verify the procedure/results wherein the SAP2000 results were compared to simple hand calculations. Appendix D contains the report that shows the verification of the procedure

that was followed for the determination of the vehicular live load values as well as an outline of the procedure itself.

The centerline of the truck wheels were positioned at least 2 feet from the edge of each design lane as specified in the AASHTO Bridge Specifications Article 3.6.1.3.1 (AASHTO 2008). The design lane for Stage IV, Load Case 10 (See Figures 5.28, 5.29, 5.33, 5.34, and 5.35, and 6.2) was taken from the temporary barrier near the construction joint to the new barrier rail. The lane was modeled this way because traffic may be on this area of the bridge depending on how the temporary rail is tapered.

The raw live load data obtained from SAP2000 is not per foot of deck. The values obtained must be distributed over an equivalent width. The equivalent widths are determined using Table 4.6.2.1.3-1 of the AASHTO Specifications (AASHTO 2008). This table is shown in Table 6.3. The variable S in the table is the spacing of supporting components. 8ft is used for the test bridges since the girders are spaced 8ft apart. Substituting this value into the equations yields an effective width of 6.57ft for negative moments and 6ft for positive moments. The live load moments obtained from SAP2000 are divided by these effective width values to yield a value per foot of decking. The live load values must also be multiplied by a multiple presence factor that accommodates for the probability of multiple design vehicles being on the bridge at the same time. This factor is determined by using Table 3.6.1.1.2-1 of the AASHTO Bridge Specifications (AASHTO 2008). A replica of this table is shown in Table 6.4. This factor is not used for the fatigue limit state.

Table 6.3 Equivalent Strips

[Taken from AASHTO (2007)]

Type of Deck	Direction of Primary Strip Relative to Traffic	Width of Primary Strip (in.)
Concrete:		
<ul style="list-style-type: none"> • Cast-in-place 	Overhang	$45.0 + 10.0X$
	Either Parallel or Perpendicular	+M: $26.0 + 6.6S$ -M: $48.0 + 3.0S$
	<ul style="list-style-type: none"> • Cast-in-place with stay-in-place concrete formwork 	Either Parallel or Perpendicular
<ul style="list-style-type: none"> • Precast, post-tensioned 		Either Parallel or Perpendicular
Steel:		
<ul style="list-style-type: none"> • Open grid • Filled or partially filled grid • Unfilled, composite grids 	Main Bars	$1.25P + 4.0S_b$
	Main Bars	Article 4.6.2.1.8 applies
	Main Bars	Article 4.6.2.1.8 applies
Wood:		
<ul style="list-style-type: none"> • Prefabricated glulam <ul style="list-style-type: none"> ○ Noninterconnected 	Parallel	$2.0h + 30.0$
	Perpendicular	$2.0h + 40.0$
<ul style="list-style-type: none"> ○ Interconnected 	Parallel	$90.0 + 0.84L$
	Perpendicular	$4.0h + 30.0$
<ul style="list-style-type: none"> • Stress-laminated 	Parallel	$0.8S + 108.0$
	Perpendicular	$10.0S + 24.0$
<ul style="list-style-type: none"> • Spike-laminated <ul style="list-style-type: none"> ○ Continuous decks or interconnected panels 	Parallel	$2.0h + 30.0$
	Perpendicular	$4.0h + 40.0$
<ul style="list-style-type: none"> ○ Noninterconnected panels 	Parallel	$2.0h + 30.0$
	Perpendicular	$2.0h + 40.0$

Table 6.4 Multiple Presence Factor, m

[Taken from AASHTO (2007)]

Number of Loaded Lanes	Multiple Presence Factors <i>m</i>
1	1.20
2	1.00
3	0.85
>3	0.65

The static vehicular live loads previously found must be amplified to accommodate for dynamic effects. These values are amplified by using a dynamic load allowance factor (IM). This amplification factor is found in Table 3.6.2.1-1 of the AASHTO Bridge Specifications (AASHTO 2008). This value varies depending on the component and limit state being considered. Table 6.5 shows these values and is a direct copy of Table 3.6.2.1-1 of the AASHTO Bridge Specifications (AASHTO 2008). The static vehicular live load is increased by the applicable percentage from Table 6.5.

Table 6.5 Dynamic Load Allowance, IM

[Taken from AASHTO (2007)]

Component	IM
Deck Joints—All Limit States	75%
All Other Components	
• Fatigue and Fracture Limit State	15%
• All Other Limit States	33%

The loads due to wind pressure on vehicles (WL) are determined in accordance with Article 3.8.1.3 of the AASHTO Bridge Specifications (AASHTO 2008). The specifications state that the “wind pressure on vehicles shall be represented by an interruptible, moving force of 0.10-klf acting normal to, and 6.0-ft. above, the roadway and shall be transmitted to the structure.” A design truck trailer of 32-ft is assumed for the WL calculations. Figure 6.5 shows the wind load acting on the assumed design truck. The loads acting at the deck surface due to the wind load were calculated and these loads were modeled in SAP2000 following the same procedure as used for the LL calculations. Wind in both directions was considered. Similar to the LL calculations, the values from SAP2000 were distributed over an equivalent width. The lengths of these equivalent strips were determined using Table 6.3. This was done for all four systems.

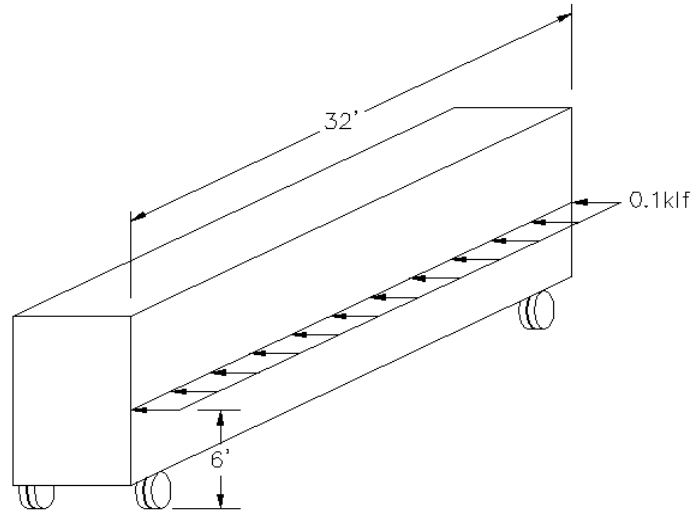

Figure 6.7 Wind on Design Vehicle

The deck overhangs must be design to withstand a vehicle collision with the barrier rail. The vehicle collision load (CT) shall be determined in accordance to Section 13 of the AASHTO Bridge Specifications (AASHTO 2008). The deck overhang design requirements are outlined in Section A13.4 of the specifications.

After all of the load components are determined, they are factored in the load combination limit states of interest. The Strength I, Service I, Fatigue, and Extreme Event II load combination limit states are of interest for the deck design. These limit states are defined in 3.4.1 of the AASHTO Bridge Specifications (AASHTO 2008). The Strength I limit state is the “basic load combination relating to the normal vehicular use of the bridge without wind.” The Service I limit state is the “load combination relating to the normal operational use of the bridge with a 55 mph wind and all loads taken at their normal values.” This limit state is “also related to control crack width in reinforced concrete structures.” The Fatigue limit state is the “load combination relating to repetitive gravitational vehicle live load and dynamic responses under a single design truck.” The Extreme Event II load combination limit state is also of interest for the

design of the deck overhang to accommodate for barrier rail collisions. Table 6.7 is a replica of Table 3.4.1-1 of the AASHTO Bridge Specifications (2007). This table shows the load combinations and their load factors. The permanent load factor, γ_p , is determined from Table 6.7. Table 6.7 is a copy of Table 3.4.1-2 of the AASHTO Bridge Specifications (AASHTO 2008).

Table 6.6 Load Combinations and Load Factors

[Taken from AASHTO (2007)]

Load Combination Limit State	<i>DC</i> <i>DD</i> <i>DW</i> <i>EH</i> <i>EV</i> <i>ES</i> <i>EL</i> <i>PS</i> <i>CR</i> <i>SH</i>	<i>LL</i> <i>IM</i> <i>CE</i> <i>BR</i> <i>PL</i> <i>LS</i>	<i>WA</i>	<i>WS</i>	<i>WL</i>	<i>FR</i>	<i>TU</i>	<i>TG</i>	<i>SE</i>	Use One of These at a Time			
										<i>EQ</i>	<i>IC</i>	<i>CT</i>	<i>CV</i>
STRENGTH I (unless noted)	γ_p	1.75	1.00	—	—	1.00	0.50/1.20	γ_{TG}	γ_{SE}	—	—	—	—
STRENGTH II	γ_p	1.35	1.00	—	—	1.00	0.50/1.20	γ_{TG}	γ_{SE}	—	—	—	—
STRENGTH III	γ_p	—	1.00	1.40	—	1.00	0.50/1.20	γ_{TG}	γ_{SE}	—	—	—	—
STRENGTH IV	γ_p	—	1.00	—	—	1.00	0.50/1.20	—	—	—	—	—	—
STRENGTH V	γ_p	1.35	1.00	0.40	1.0	1.00	0.50/1.20	γ_{TG}	γ_{SE}	—	—	—	—
EXTREME EVENT I	γ_p	γ_{EQ}	1.00	—	—	1.00	—	—	—	1.00	—	—	—
EXTREME EVENT II	γ_p	0.50	1.00	—	—	1.00	—	—	—	—	1.00	1.00	1.00
SERVICE I	1.00	1.00	1.00	0.30	1.0	1.00	1.00/1.20	γ_{TG}	γ_{SE}	—	—	—	—
SERVICE II	1.00	1.30	1.00	—	—	1.00	1.00/1.20	—	—	—	—	—	—
SERVICE III	1.00	0.80	1.00	—	—	1.00	1.00/1.20	γ_{TG}	γ_{SE}	—	—	—	—
SERVICE IV	1.00	—	1.00	0.70	—	1.00	1.00/1.20	—	1.0	—	—	—	—
FATIGUE— <i>LL, IM & CE</i> ONLY	—	0.75	—	—	—	—	—	—	—	—	—	—	—

Table 6.7 Load Factors for Permanent Loads, γ_p

[Taken from AASHTO (2007)]

Type of Load, Foundation Type, and Method Used to Calculate Downdrag		Load Factor	
		Maximum	Minimum
<i>DC</i> : Component and Attachments		1.25	0.90
<i>DC</i> : Strength IV only		1.50	0.90
<i>DD</i> : Downdrag	Piles, α Tomlinson Method	1.4	0.25
	Piles, λ Method	1.05	0.30
	Drilled shafts, O'Neill and Reese (1999) Method	1.25	0.35
<i>DW</i> : Wearing Surfaces and Utilities		1.50	0.65
<i>EH</i> : Horizontal Earth Pressure			
• Active		1.50	0.90
• At-Rest		1.35	0.90
• <i>AEP</i> for anchored walls		1.35	N/A
<i>EL</i> : Locked-in Construction Stresses		1.00	1.00
<i>EV</i> : Vertical Earth Pressure			
• Overall Stability		1.00	N/A
• Retaining Walls and Abutments		1.35	1.00
• Rigid Buried Structure		1.30	0.90
• Rigid Frames		1.35	0.90
• Flexible Buried Structures other than Metal Box Culverts		1.95	0.90
• Flexible Metal Box Culverts		1.50	0.90
<i>ES</i> : Earth Surcharge		1.50	0.75

Equation 6.1 must be met for all components and connections for each limit state. This is equation 1.3.2.1-1 of the AASHTO Bridge Specifications (AASHTO 2008).

$$\sum \eta_i \gamma_i Q_i \leq \phi R_n \quad (6.1)$$

$$\eta_i = \eta_D \eta_R \eta_I \geq 0.95 \quad (6.2)$$

$$\eta_i = \frac{1}{\eta_D \eta_R \eta_I} \leq 1.0 \quad (6.3)$$

Where η_i is a load modifier relating to ductility, redundancy, and operation importance, γ_i is the load factor determined from Table 6.6, Q_i is the force effect, ϕ is the resistance factor, and R_n is the nominal resistance. Definition for the load modifier, η_i , is shown in Equations 6.2 and 6.3. Equation 6.2 is used when maximum values of η_i is appropriate and Equation 6.3 is used when minimum values are appropriate. η_D is the load factor relating to ductility, η_R is the load factor relating to redundancy, and η_I is the load factor relating to operational importance. See Section 1.3.2 of the AASHTO Bridge Specifications for further details (AASHTO 2008).

The load modifier, η_i , is taken as 1.0 for non-strength limit states as specified by Article C1.3.2.1 of the AASHTO Bridge Specifications (AASHTO 2008). A value of 1.0 was chosen for the load factor relating to ductility, η_D , because of compliance with AASHTO Bridge Specifications (AASHTO 2008). A value of 1.05 was chosen for the load factor relating to redundancy, η_R , for the deck overhang regions. The Article 1.3.4 of the AASHTO Bridge Specifications requires a value at least this much for non-redundant members such as the overhang region (AASHTO 2008). This arbitrary value satisfies the specifications requirement. The redundancy load factor was taken as 1.0 for the rest of the deck since the bridges have more than two supports. The importance load factor, η_I , was taken as 1.0 since this is a typical bridge and is not of high importance.

6.1.2. Deck Design

Each deck system was designed for the final load case. There are a few steps during the construction sequence that may control the design of a deck system, but consideration of these load cases is out of the scope of this project.

6.1.3. Deck Overhang Design

The forces to be transmitted from the bridge railing to the bridge deck overhang due to a vehicle collision with the barrier are determined from an ultimate strength analysis of the railing system using the loads described in Article A13.2 of the AASHTO Bridge Specifications (AASHTO 2008). Those forces shall be considered to be the factored loads at the extreme event limit state per Article 13.6.2 of the AASHTO Bridge Specifications (AASHTO 2008). The calculated transmitted forces were found to be as follows. The axial tension, T , was determined to be 5.3-kips/ft and the moment was determined to be -16.7-kip-ft/ft. The deck overhang design requirements were

determined for each of the deck systems and these requirements are given in Sections 6.2.3, 6.3.3, 6.4.3 and 6.5.3.

6.1.4. Connection Details

Conceptual connection details for each of the four deck systems are shown in Chapter 4. The adequacy of these details is unknown and verification is out of the scope of this report.

6.2. NCHRP Full-Depth Precast Deck System

6.2.1. Load Calculations

The Strength I, Service I, and Extreme Event load combination limit states are considered for the design of the NCHRP full-depth deck system. The loads for this deck system were determined as outlined in 6.1.1. Normal-weight reinforced concrete is generally accepted to have a density of 150-pcf. The deck dead load was conservatively estimated by considering a deck weight of 160-pcf. The loads and load effects for the NCHRP full-depth deck systems were calculated, and the results from these calculations are given below.

The live load moments are shown in Figure 6.6 for the final load case. There are three different live load cases; only lane 1 loaded, only lane 2 loaded, and both lanes loaded simultaneously. Each case controls at different locations along the cross-section. The moment values that result from wind pressure on the design truck are shown in Figure 6.7 for the final load case. Wind in both directions was considered.

The different dead load components were all graphed on the same chart for the final load case. This provides a comparison of the load effects imposed by each. The chart is shown in Figure 6.8 for moment load effects. The load effects for each of the loads, except for the collision load, are shown in Figure 6.9 for the final load case. Finally, the Strength I and Service I load combination limit states are plotted in Figure 6.10.

The same process was repeated for all of the other load cases of Table 6.1. The worst case for each cross section was then used to generate a worst-case chart for each of the limit states. This envelope is shown in Figure 6.11. Comparing Figure 6.11 to Figure 6.10, it is recognizable that the final load case is typically the worst, but there are a few locations where other load cases control. Since the strip method will be used, the extreme positive moment was used in all positive regions for the design of the deck as required by AASHTO Bridge Specifications Article 4.6.2.1.1 (AASHTO 2008). Similarly, the extreme negative moment was used at all negative sections for the deck design. The extreme positive and negative moments for the Strength I, Service I, and Extreme Event load combination limit states are summarized in Table 6.8.

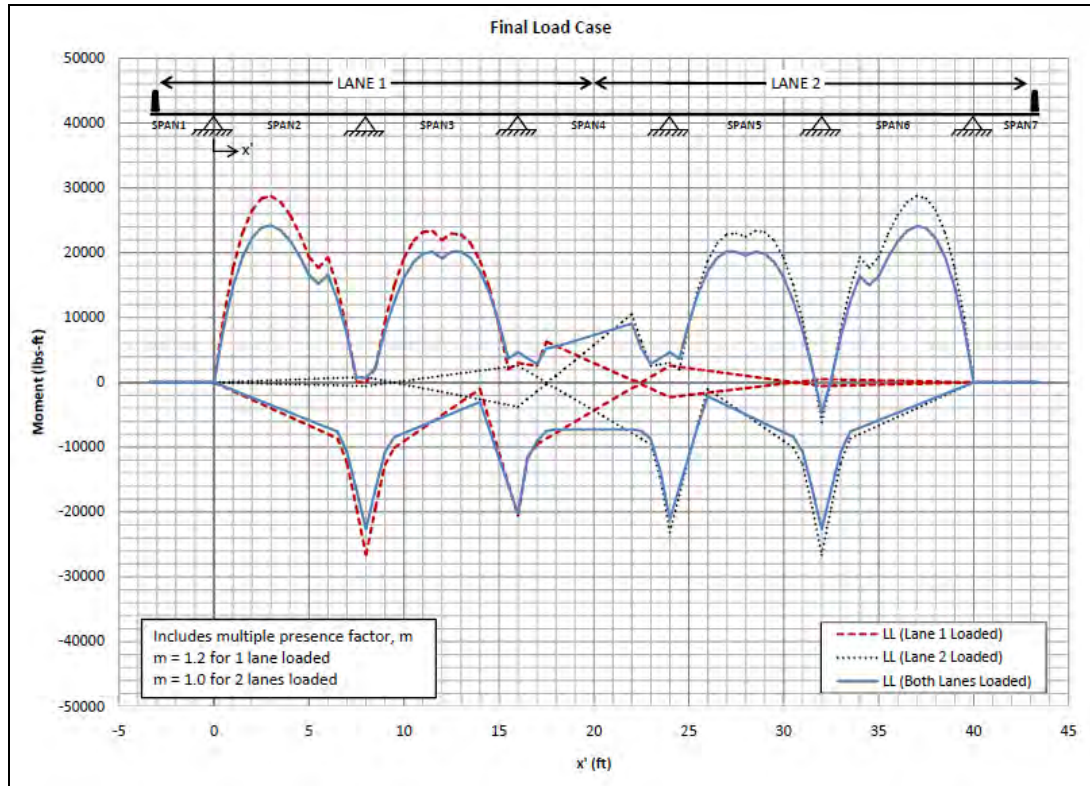

Figure 6.8 Live Load Moments for Final Load Case

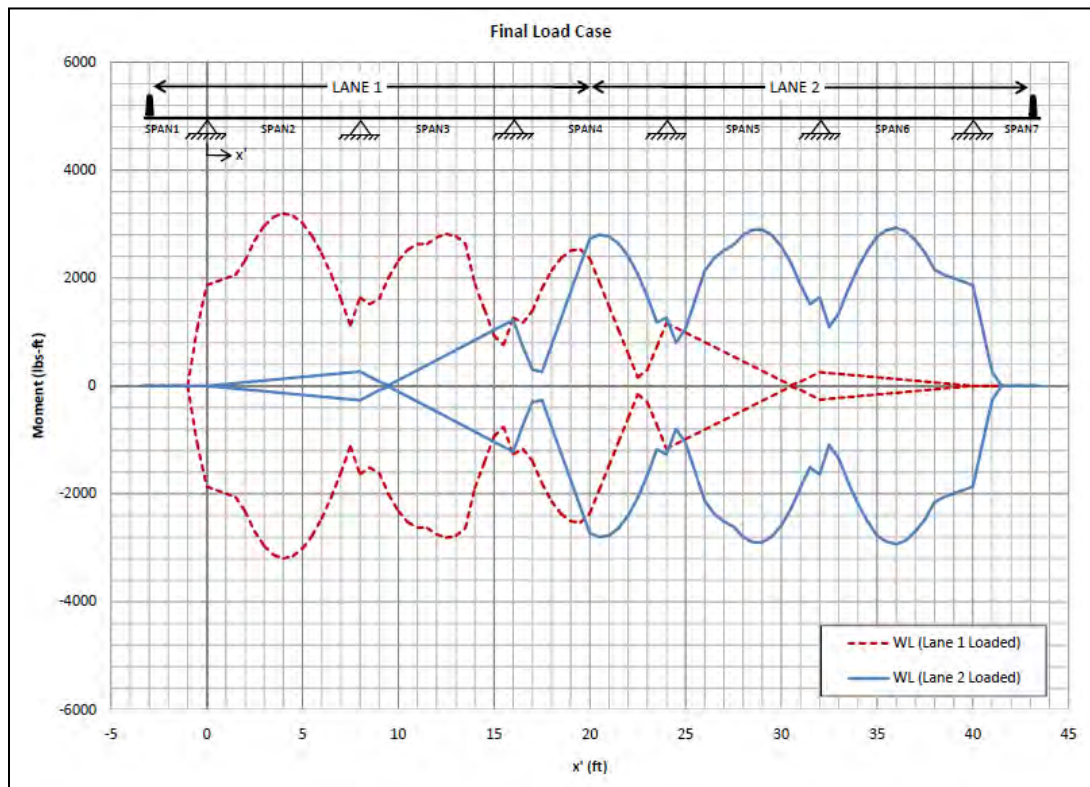

Figure 6.9 Wind on Live Load for Final Load Case

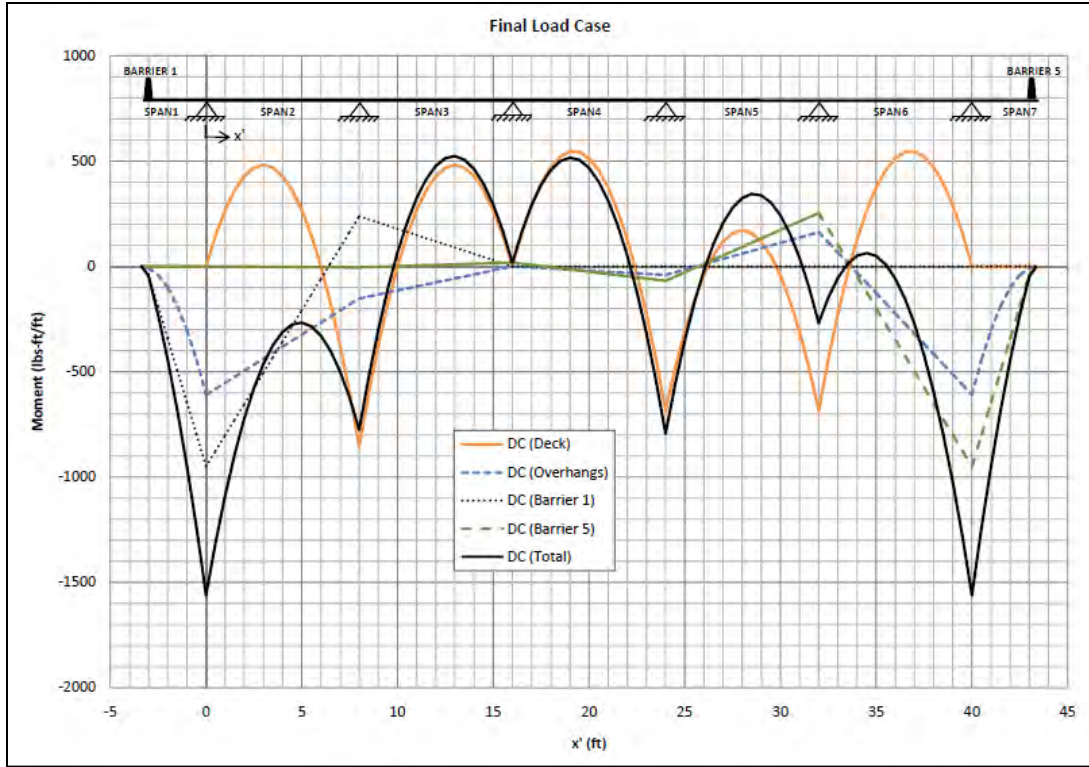

Figure 6.10 Dead Load Moments for Final Load Case

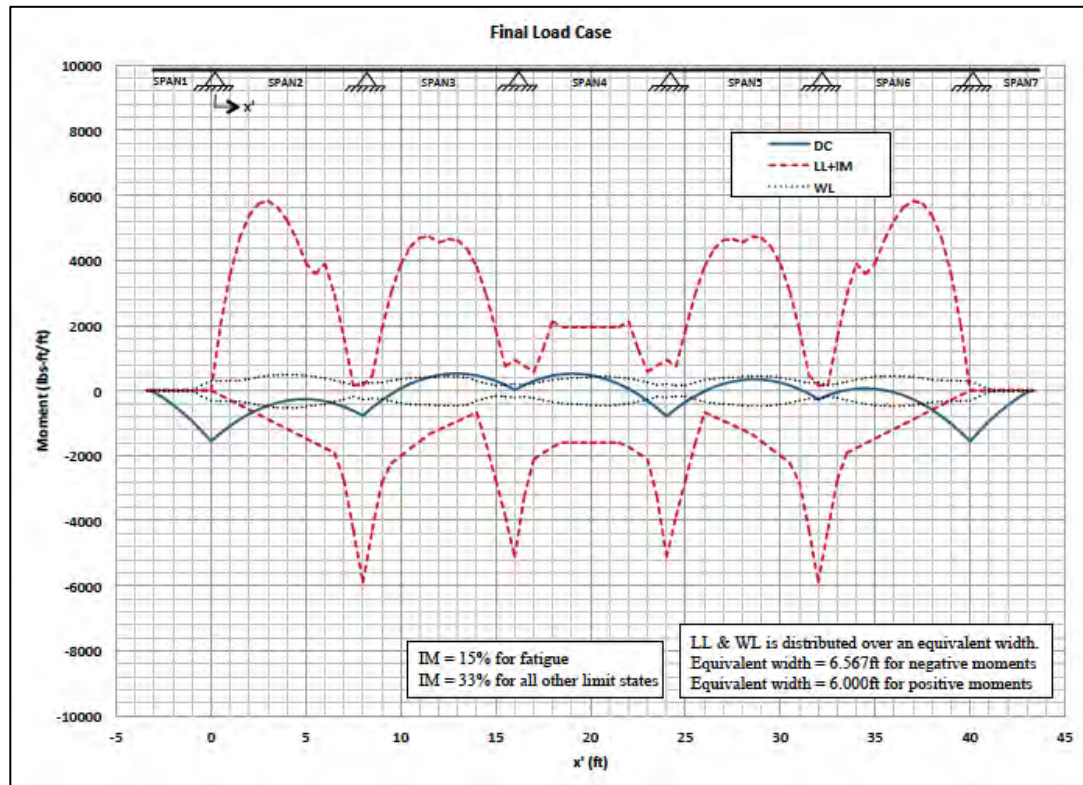

Figure 6.11 Moments for Final Load Case

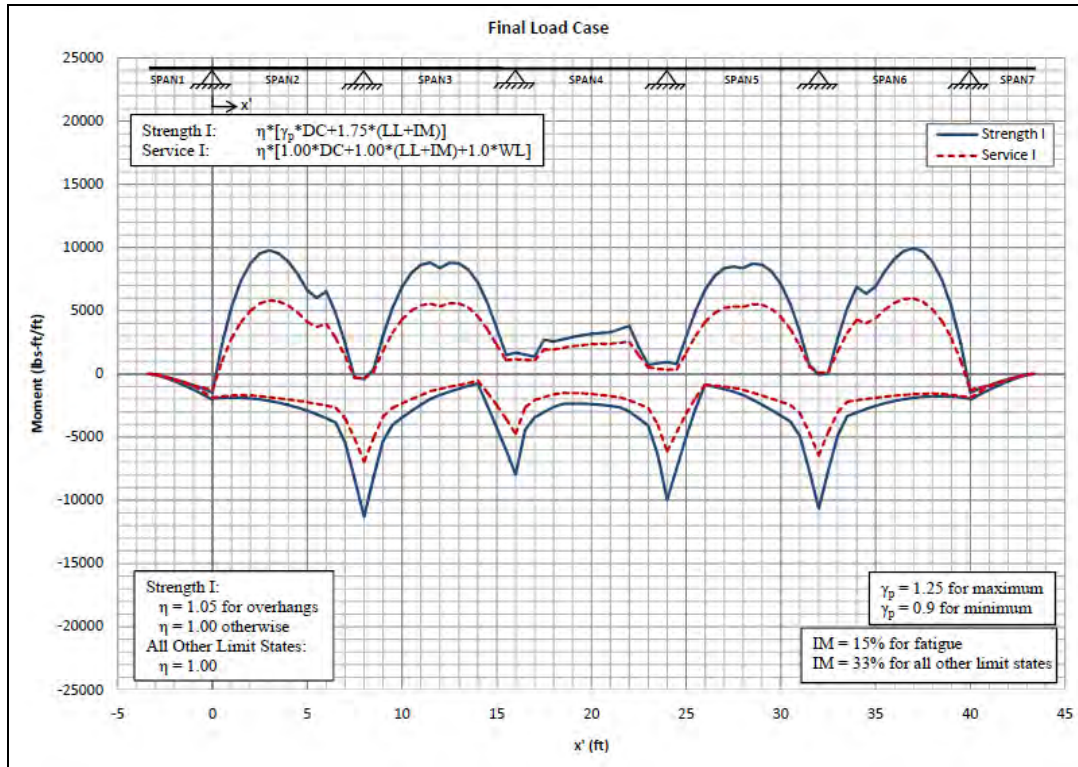

Figure 6.12 Moment Limit States for Final Load Case

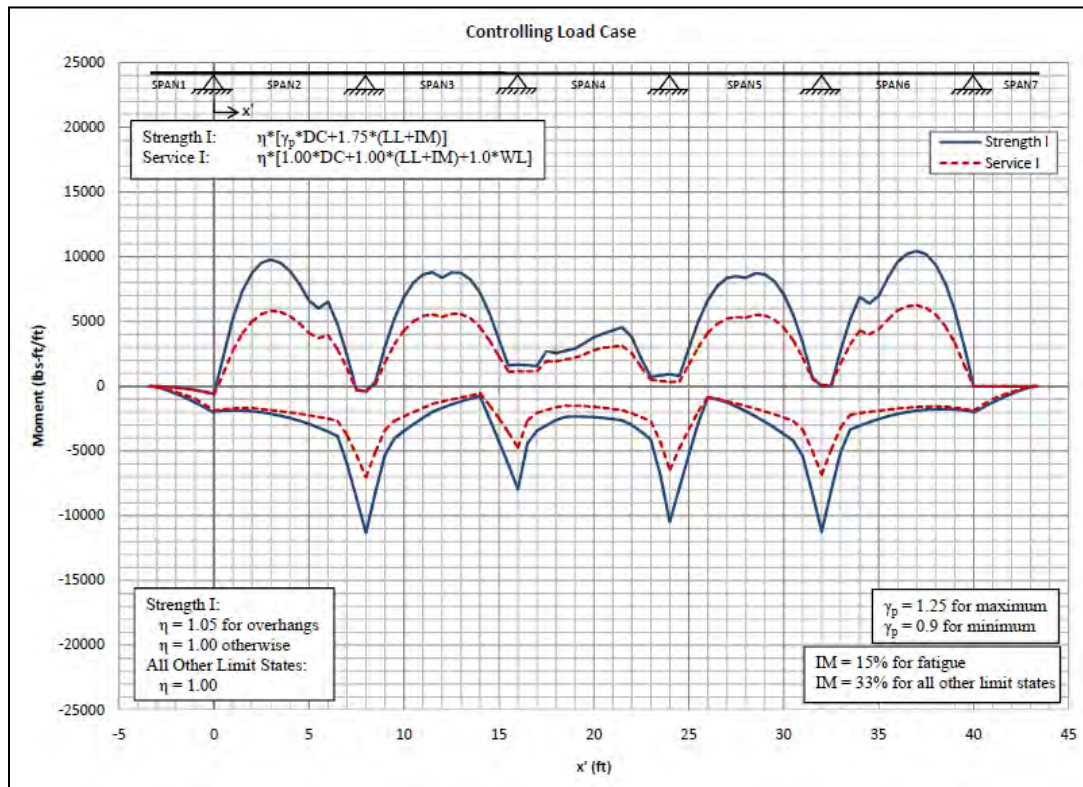

Figure 6.13 Moment Envelope for Limit States

Table 6.8 NCHRP Full-Depth Deck System Extreme Moment Values

Limit State	Moment (lbs-ft/ft)	
	Extreme Positive	Extreme Negative
Strength I	10441	-11321
Service I	6251	-7024
Extreme Event	N/A	-18290

6.2.2. Deck Design

The NCHRP full-depth deck system was designed for a girder spacing of 12-ft. This design could be refined for our application since the test bridges have girders that are spaced at 8-ft. However, using the existing design is conservative for this project. The design of this system was verified against the Strength I and Service I limit states. The Service I limit state includes the control of crack width and deflection limits.

Strength I limit state calculations were performed and the factored negative and positive moment capacities determined from these calculations were -20.4-kip-ft/ft and 20.4-kip-ft/ft. The controlling Strength I load effect minimum and maximum moments on this deck system are -11.3-kip-ft/ft and 10.4-kip-ft/ft respectively. This deck system design is adequate for the Strength I limit state since the resistance is greater than the load effect.

The spacing of the mild steel reinforcement in the layer closest to the tension face is restricted by AASHTO Bridge Specifications Article 5.7.3.4 to control cracking (AASHTO 2008). The maximum spacing was calculated to be 165 inches for the bottom mild steel reinforcement and 95 inches for the top. Since the maximum spacing of the mild steel reinforcement is 9.5 inches, which is much less than the maximum allowable

spacing, the design is adequate for the control of crack width. It is suspected that the large values are due to the prestressed reinforcing steel.

The maximum live load deflection was determined by modeling the live load truck in SAP2000. The deflection value taken from SAP2000 was made independent of the stiffness of the deck. The deflection for each of the systems is therefore determined by dividing the value from SAP2000 by the modulus of elasticity and the moment of inertia of the equivalent strip. The calculated deflection was much less than the maximum allowable deflection.

The design of the NCHRP full-depth deck system meets all of the AASHTO Bridge Specifications criteria and is therefore acceptable for use on the I-59 bridges (AASHTO 2008).

6.2.3. Deck Overhang Design

It has been calculated that a minimum area of 0.786-in^2 per foot of deck is required at the top of the deck for the overhang region. The NCHRP full-depth deck system has six #5 reinforcing bars, two #4 reinforcing bars, and four $\frac{1}{2}$ " 270-ksi prestressing strands within the top portion of the deck over a panel width of 8-ft. The contribution from the prestressing strands is neglected because they will not be able to adequately develop to provide resistance in this region. This reinforcement provides an area of steel equal to 0.286-in^2 per foot of deck. So an additional 0.5-in^2 per foot of deck must be supplied in the top portion of the deck overhang to meet the required minimum area of steel. Adding #5 reinforcing bars spaced at 7 inches center-to-center will provide this additional requirement. These bars shall be placed as close to the top of the deck surface as possible while satisfying concrete cover requirements.

The reinforcement that is used to resist the effects of a vehicle collision must adequately develop from the critical section shown in Figure 6.12. The available development length is equal to 12.37 inches, as shown in the figure, minus the required cover. This leaves an available development length of 9.87 inches. This value was determined using a cover of 2.5 inches to take advantage of the 0.7 factor for adequate cover as describe in Article 5.11.2.4.2 of the AAHSTO Bridge Specifications (AASHTO 2008).

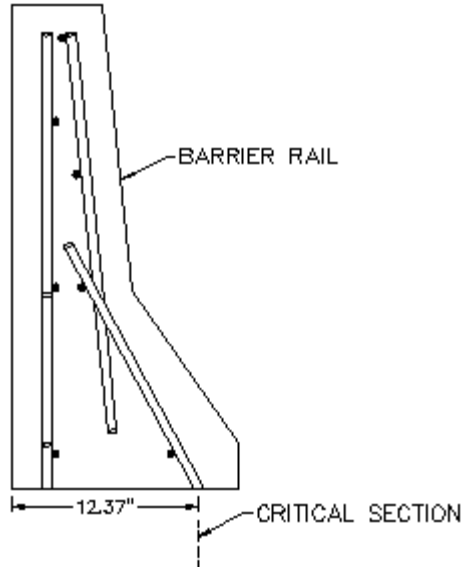
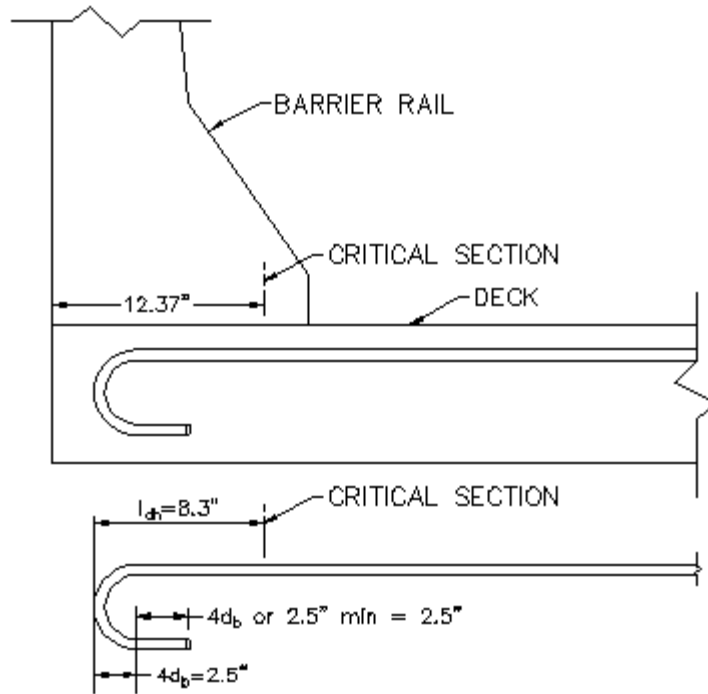

Figure 6.14 Critical Section Location of Barrier Rail for Vehicle Collision

The required development length for the #5 reinforcing bars was determined from Equation 5.11.2.4.1-1 of the AASHTO Bridge Specification. Using a modification factor of 0.7 for adequate cover, the development length required for a standard hook is 8.3 inches. This was determined considering a 28-day concrete compressive strength of 4-ksi. The concrete of the NCHRP full-depth system has a larger compressive strength, but the use of 4-ksi results in a conservative development length. The development length needed for the #4 reinforcing bars is not calculated since #4 reinforcing bars will require a smaller development length than the #5 reinforcing bars. The required development length of 8.3 inches is less than the available space for development, 9.87 inches. Thus, the reinforcing bars will have adequate room to develop for a 180-degree hook. Refer to Figure 6.13 for required reinforcing bar dimensions.



Refer to AASHTO Figure C5.11.2.4-1
 Figure 6.15 Required Reinforcing Bar Dimensions

6.3. Exodermic Precast Deck System

6.3.1. Load Calculations

The loads for this deck system were determined as outlined in 6.1.1. The extreme positive and negative moments are summarized in Table 6.9.

Table 6.9 Exodermic Precast Deck System Extreme Moment Values

Limit States	Moment (lbs-ft/ft)	
	Extreme Positive	Extreme Negative
Strength I	12877	-14389
Service I	7985	-8597
Service II	9992	-10605
Fatigue	3617	-3617
Extreme Event	N/A	-18324

6.3.2. Deck Design

The Exodermic precast deck system was designed for the Strength I, Service I, Service II, Fatigue and Extreme Event load combination limit states. The Service I limit state is used to limit the deflection of the deck system. The Service II limit state is used to control yielding of the steel.

Strength I limit state calculations were performed and the factored negative and positive flexural capacity determined from these calculation were -21.4-kip-ft/ft and 37.0-kip-ft/ft respectively. The deck system was analyzed using plastic section properties for these calculations as permitted by AASHTO Bridge Specifications Article 9.5.4 (AASHTO 2008). The controlling Strength I load effect minimum and maximum moments on this deck system are -14.4-kip-ft/ft and 12.9-kip-ft/ft respectively. The load resistance is greater than the load effect, thus the design of this deck system is adequate for the Strength I limit state.

The deflection for this deck system was determined in accordance with AASHTO Bridge Specifications Section 4.6.2.1.8 (AASHTO 2008). The computed deflection was much less than the deflection limit provided in AASHTO Bridge Specifications Section 9.5.2, thus the design is adequate for the Service I deflection limit state (AASHTO 2008).

The Service II limit state load calculations for the control of yielding of steel found that the negative and positive moments that correspond to first yielding of steel are -12.2-kip-ft/ft and 38.4-kip-ft/ft respectively. The deck system was analyzed as fully elastic for these calculations as required by AASHTO Bridge Specifications Article 9.5.2, thus transformed cracked section properties were used (AASHTO 2008). These values were compared to the minimum and maximum Service II limit state load effects of -8.6-kip-

ft/ft and 8.0-kip-ft/ft respectively. The design of this system is adequate for this limit state since the moment that first causes yielding of the steel is less than the moments applied to the deck system.

The welds on the distribution bars must be checked for fatigue. The weld at the bottom of the distribution bar will experience the worst stresses for positive flexure. The fatigue of this weld was determined to be okay for positive flexure. The weld at the top of the distribution bar will experience the worst stresses for negative flexure. The fatigue stress at this weld due to negative flexure is greater than the allowable stress; however, a study of many similar in-service grid decks concluded that fatigue has not been a problem for negative flexure. It is currently being proposed to AASHTO Bridge Committee to modify this requirement for grid deck systems. This proposal, which further discusses this discrepancy, is shown in Appendix B.

The design of the Exodermic precast deck system meets all of the AASHTO Bridge Specifications criteria except the fatigue requirement for negative flexure. The fatigue requirement is disregarded per Appendix B as previously discussed. The design of this deck system is deemed to be acceptable for use on the I-59 bridges.

It should be noted that the total depth of this deck system was chosen to be close to the total depth of the NCHRP full-depth deck system to provide similar deck surface elevations. This will provide a smooth transition for traffic between the two deck systems without requiring a large haunch. This deck system is somewhat over designed to accommodate for this depth requirement.

6.3.3. Deck Overhang Design

A minimum area of 0.788-in² per foot of deck is required at the top of the deck for the overhang region. The Exodermic deck system has #5 reinforcing bars spaced at 5 inches center-to-center. This reinforcement provides an area of steel equal to 0.744-in² per foot of deck. So an additional 0.044-in² per foot of deck is required in the top portion of the deck overhang to meet the minimum area of steel. This is rather small and is disregarded. The deck system is acceptable as is for the overhang region.

The reinforcing bars are required to be developed to resist the loads associated with a barrier rail collision. The development requirements are the same as those determined in Section 6.2.3. Refer to Figure 6.13 for required reinforcing bar dimensions.

6.4. Exodermic Cast-in-Place Deck System

6.4.1. Load Calculations

The loads were determined as outlined in 6.1.1. The extreme positive and negative moments are summarized in Table 6.10.

Table 6.10 Exodermic Cast-in-Place Deck System Extreme Moment Values

Limit State	Moment (lbs-ft/ft)	
	Extreme Positive	Extreme Negative
Strength I	12842	-14366
Service I	7983	-8580
Service II	9990	-10588
Fatigue	3617	-3617
Extreme Event	N/A	-18308

6.4.2. Deck Design

The Exodermic cast-in-place deck system was designed for the Strength I, Service I, Service II, Fatigue, and Extreme Event load combination limit states. The Service I limit state is used to limit the deflection of the deck system. The Service II limit state is used to control yielding of the steel. The same design as the Exodermic precast deck system was chosen for this system to simplify the manufacturing process.

Strength I limit state calculations were made, and the factored negative and positive flexural capacity determined from these calculations were -21.4-kip-ft/ft and 37.0-kip-ft/ft respectively. The deck system was analyzed using plastic section properties for these calculations as permitted by AASHTO Bridge Specifications Article 9.5.4 (AASHTO 2008). The controlling Strength I load effect minimum and maximum moments on this deck system are -14.4-kip-ft/ft and 12.8-kip-ft/ft respectively. The load resistance is greater than the load effect, thus the design of this deck system is adequate for the Strength I limit state.

The deflection check for this system is accomplished by following the same procedure as for the Exodermic precast deck system. The computed deflection was much less than the deflection limit, thus the design is adequate for the Service I deflection limit state.

The Service II limit state load calculations for the control of yielding of steel found the negative and positive moments that correspond to first yielding of steel to be -12.2-kip-ft/ft and 38.4-kip-ft/ft respectively. The deck system was analyzed as fully elastic for these calculations as required by AASHTO Bridge Specifications Article 9.5.2, thus transformed cracked section properties were used (AASHTO 2008). These values were

compared to the minimum and maximum Service II limit state load effects of -10.6-kip-ft/ft and 10.0-kip-ft/ft respectively. The design of this system is adequate for this limit state since the moment that first causes yielding of the steel is less than the moments applied to the deck system.

The welds on the distribution bars must be checked for fatigue. The fatigue results for this system are the same as those for the Exodermic precast deck system. The fatigue stress at the weld at the bottom end of the distribution bar is okay for positive flexure, but the fatigue stress at the weld at the top end of the distribution bar does not pass the fatigue requirement for negative flexure. As previously mentioned for the Exodermic precast deck system, the negative flexure requirement is dismissed due to the performance of several similar in-service grid decks as described in Appendix B.

The design of the Exodermic cast-in-place deck system meets all of the AASHTO Bridge Specifications criteria except the fatigue requirement for negative flexure. The fatigue requirement is disregarded per Appendix B as previously discussed. The design of this deck system is deemed to be acceptable for use on the I-59 bridges.

This deck system is somewhat over designed because the same design as the Exodermic precast system was chosen, which was over designed to accommodate for a total depth similar to the precast NCHRP full-depth system.

6.4.3. Deck Overhang Design

The design requirements for the deck overhang are the same for the Exodermic cast-in-place deck system as that of the Exodermic precast deck system. Since the two systems have the same design and the overhang portion of the Exodermic precast system

is acceptable as is, the overhang design is adequate for the Exodermic cast-in-place deck system without modifications.

The reinforcing bars are required to be developed to resist the loads associated with a barrier rail collision. The development requirements are the same as those determined in Section 6.2.3. Refer to Figure 6.13 for required reinforcing bar dimensions.

6.5. Steel Grid Partial-depth Cast-in-Place Deck System

6.5.1. Load Calculations

The loads were determined as outlined in 6.1.1. The extreme positive and negative moments are summarized in Table 6.11.

Table 6.11 Steel Grid Deck System Extreme Moment Values

Limit State	Moment (lbs-ft/ft)	
	Extreme Positive	Extreme Negative
Strength I	13268	-14931
Service I	8141	-8891
Service II	10238	-10988
Fatigue	3778	-3778
Extreme Event	N/A	-18319

6.5.2. Deck Design

The steel grid cast-in-place deck system was designed for the Strength I, Service I, Service II, Fatigue, and Extreme Event load combination limit states. The Service I limit state is used to limit the deflection of the deck system. The Service II limit state is used to control yielding of the steel.

The factored negative and positive flexural capacity values for the Strength I limit state were determined to be -20.4-kip-ft/ft and 37.8-kip-ft/ft respectively. The deck

system was analyzed using plastic section properties for these calculations per AASHTO Bridge Specifications Article 9.5.4 (AASHTO 2008). The controlling Strength I load effect minimum and maximum moments on the deck system are -14.9-kip-ft/ft and 13.3-kip-ft/ft. The flexural capacity is greater than the load effect for both positive and negative flexure, thus the design of this deck system is adequate for the Strength I limit state.

The deflection check for this system is accomplished by following the same procedure as for the Exodermic deck systems. The computed deflection was much less than the deflection limit, thus the design is adequate for the Service I deflection limit state.

The Service II limit state load calculations that pertain to the control of yielding of steel found the negative and positive moments corresponding to yielding of the steel to be -20.2-kip-ft/ft and 43.4-kip-ft/ft respectively. Transformed cracked section properties were used since the deck system was analyzed as fully elastic for these calculations per AASHTO Bridge Specifications Article 9.5.2 (AASHTO 2008). These values were compared to the minimum and maximum Service II limit state load effects of -11.0-kip-ft/ft and 10.2-kip-ft/ft respectively. The design of this system is adequate for this limit state since the moment that first causes yielding of the steel is less than the moments applied to the deck system.

The welds along the crossbars are to be checked for fatigue per AASHTO Bridge Specifications Article 9.5.3 (AASHTO 2008). The weld at the bottom of the crossbar will experience the worst stress for positive flexure. The fatigue stress at this weld is less than the allowable fatigue stress. Thus this weld is okay for fatigue. The weld at the top

of the crossbar experiences the worst stress for negative flexure. The fatigue stress at this weld is not less than the allowable fatigue stress. Although the fatigue requirements aren't met for the stress at this weld, this violation was disregarded for the same reason previously explained for the Exodermic deck systems.

The design of the steel grid cast-in-place deck system meets all of the AASHTO Bridge Specifications criteria except for the fatigue requirement for negative flexure. Since the fatigue requirement is neglected per Appendix B, the design of this deck system is considered acceptable for use on the I-59 bridges.

The total depth of this deck system was chosen to be close to the total depth of the Exodermic cast-in-place deck system. Since the Exodermic cast-in-place deck system is over designed due to excessive thickness, this system is also over designed as explained in Section 6.4.2.

6.5.3. Deck Overhang Design

Calculations were performed and it was determined that a minimum area of 0.787-in² per foot of deck is required at the top of the deck for the overhang region. The steel grid deck system has no reinforcing bars in this area as designed. The crossbars may provide some resistance, but it is assumed that they do not for this study. Hence, #5 bars spaced at 4 inches center-to-center in the top region of the deck overhang will provide adequate resistance. These bars shall be placed as close to the top of the deck surface as possible without violating concrete cover requirements.

The reinforcing bars are required to be developed to resist the loads associated with a barrier rail collision. The development requirements are the same as those determined in Section 6.2.3. Refer to Figure 6.13 for required reinforcing bar dimensions.

6.6. Barrier Rails

The Alabama Department of Transportation (ALDOT) requires the bridge railing for the I-59 Collinsville bridges to be rated at least Test Level Four (TL-4). TL-4 is “generally acceptable for the majority of applications on high speed highways, freeways, expressways, and interstate highways with a mixture of trucks and heavy vehicles” as described in Article 13.7.2 of the AASHTO Bridge Specifications (AASHTO 2008). It is recommended for ALDOT’s standard barrier rail, shown in Figure 4.8, to be used for the test bridges. It is lightweight in comparison to other TL-4 rated barrier rails as stated in Chapter 4. Moreover, this barrier rail is a previously tested crashworthy system so additional crash testing is not required as long as minor modifications don’t change the performance of the railing system as permitted by Article A13.7.3.1.1 of the AASHTO Bridge Specifications (AASHTO 2008). Although this barrier rail is a previously tested crashworthy system, a verification of the crash test rating as well as minimum reinforcement and development requirements of the reinforcement can be found in Appendix A.

It should be noted that the design of the approach railing system is not considered in this study. The “approach railing system should include a transition guardrail system to the rigid bridge railing system that is capable of providing lateral resistance to an errant vehicle” and shall also include a “crashworthy end terminal at its nosing” as required by Article 13.7.1.2 of the AASHTO Bridge Specifications (AASHTO 2008).

7. Design Adequacy of the Four Superstructure Systems

7.1. General

The adequacy and performance of each of the deck systems acting compositely with their supporting components are investigated in this chapter. Design ratios are determined for limit states of interest at critical locations along each of the spans. Design ratios greater than one are considered acceptable. The design ratios are determined by modifying Equation 6.1 as shown in Equation 7.1.

$$Design\ Ratio = \frac{\phi R_n}{\sum \eta_i \gamma_i Q_i} \quad (7.1)$$

7.2. Load Calculations

Load calculations are required to determine the design ratios for each of the four deck systems. The longitudinal load calculations for each of the sections of interest were performed and a summary of these loads are shown in Tables 7.1 and 7.2 for the interior and exterior girders respectively. Dead loads and live loads were considered and a general outline of the calculation procedure and assumptions that were made are as follows.

Table 7.1 Load Summary for Interior Girders

Interior Girders								
Deck System	Select Internal Force Resultants ⁽¹⁾	mg ⁽²⁾	LL+IM	mg× (LL+IM)	DC	Strength I	Service II	Fatigue
Exodermic Cast-in-Place	M _{max}	0.692	1219	844	322	1879	1418	N/A
	V _{max}	0.814	98	80	22	166	125	N/A
	M _{cvrplt}	0.692	1033	715	240	1551	1170	N/A
	Mfat _{cvrplt}	0.692	497	344	N/A	N/A	N/A	258
	Mfat _{diaph}	0.692	591	409	N/A	N/A	N/A	307
	Vfat _{studs,end}	0.814	56	45	N/A	N/A	N/A	34
	Vfat _{studs,mid}	0.814	18	15	N/A	N/A	N/A	11
Steel Grid	M _{max}	0.687	1219	838	369	1927	1458	N/A
	V _{max}	0.814	98	80	25	171	129	N/A
	M _{cvrplt}	0.687	1033	710	276	1586	1198	N/A
	Mfat _{cvrplt}	0.687	497	341	N/A	N/A	N/A	256
	Mfat _{diaph}	0.687	591	406	N/A	N/A	N/A	305
	Vfat _{studs,end}	0.814	56	45	N/A	N/A	N/A	34
	Vfat _{studs,mid}	0.814	18	15	N/A	N/A	N/A	11
Exodermic Precast	M _{max}	0.692	1219	844	325	1882	1422	N/A
	V _{max}	0.814	98	80	22	167	125	N/A
	M _{cvrplt}	0.692	1033	715	243	1554	1172	N/A
	Mfat _{cvrplt}	0.692	497	344	N/A	N/A	N/A	258
	Mfat _{diaph}	0.692	591	409	N/A	N/A	N/A	307
	Vfat _{studs,end}	0.814	56	45	N/A	N/A	N/A	34
	Vfat _{studs,mid}	0.814	18	15	N/A	N/A	N/A	11
NCHRP	M _{max}	0.688	1219	839	428	2003	1519	N/A
	V _{max}	0.814	98	80	29	176	133	N/A
	M _{cvrplt}	0.688	1033	711	320	1644	1244	N/A
	Mfat _{cvrplt}	0.688	497	342	N/A	N/A	N/A	256
	Mfat _{diaph}	0.688	591	407	N/A	N/A	N/A	305
	Vfat _{studs,end}	0.814	56	45	N/A	N/A	N/A	34
	Vfat _{studs,mid}	0.814	18	15	N/A	N/A	N/A	11

(1) Shear (V) units are in kips, Moment (M) units are in kip-ft

(2) mg is the distribution factor

Table 7.2 Load Summary for Exterior Girders

Exterior Girders								
Deck System	Select Internal Force Resultants ⁽¹⁾	mg ⁽²⁾	LL+IM	mg× (LL+IM)	DC	Strength I	Service II	Fatigue
Exodermic Cast-in-Place	M _{max}	0.769	1219	938	324	2148	1543	N/A
	V _{max}	0.769	98	75	22	168	120	N/A
	M _{cvrplt}	0.769	1033	794	242	1778	1275	N/A
	Mfat _{cvrplt}	0.769	497	382	N/A	N/A	N/A	287
	Mfat _{diaph}	0.769	591	455	N/A	N/A	N/A	341
	Vfat _{studs,end}	0.769	56	43	N/A	N/A	N/A	32
	Vfat _{studs,mid}	0.769	18	14	N/A	N/A	N/A	11
Steel Grid	M _{max}	0.769	1219	938	350	2182	1569	N/A
	V _{max}	0.769	98	75	24	170	122	N/A
	M _{cvrplt}	0.769	1033	794	262	1803	1295	N/A
	Mfat _{cvrplt}	0.769	497	382	N/A	N/A	N/A	287
	Mfat _{diaph}	0.769	591	455	N/A	N/A	N/A	341
	Vfat _{studs,end}	0.769	56	43	N/A	N/A	N/A	32
	Vfat _{studs,mid}	0.769	18	14	N/A	N/A	N/A	11
Exodermic Precast	M _{max}	0.769	1219	938	330	2155	1548	N/A
	V _{max}	0.769	98	75	23	168	121	N/A
	M _{cvrplt}	0.769	1033	794	247	1783	1279	N/A
	Mfat _{cvrplt}	0.769	497	382	N/A	N/A	N/A	287
	Mfat _{diaph}	0.769	591	455	N/A	N/A	N/A	341
	Vfat _{studs,end}	0.769	56	43	N/A	N/A	N/A	32
	Vfat _{studs,mid}	0.769	18	14	N/A	N/A	N/A	11
NCHRP	M _{max}	0.769	1219	938	373	2213	1592	N/A
	V _{max}	0.769	98	75	26	172	124	N/A
	M _{cvrplt}	0.769	1033	794	279	1826	1312	N/A
	Mfat _{cvrplt}	0.769	497	382	N/A	N/A	N/A	287
	Mfat _{diaph}	0.769	591	455	N/A	N/A	N/A	341
	Vfat _{studs,end}	0.769	56	43	N/A	N/A	N/A	32
	Vfat _{studs,mid}	0.769	18	14	N/A	N/A	N/A	11

(1) Shear (V) units are in kips, Moment (M) units are in kip-ft

(2) mg is the distribution factor

The loads due to dead weight are different between the systems due to the variation in deck structure and material weights. Unit dead weights of each of the four deck systems were calculated and are shown in Table 7.3. As can be seen in the table, the NCHRP full-depth deck system is the heaviest by a considerable margin and the Exodermic deck systems are slightly lighter than the standard steel grid. Note in Table 7.3 that the unit weight of the deck overhang is considerably heavier for the Exodermic and steel grid systems due to additional concrete thickness needed in the overhang to resist barrier collision forces. The weight of the barriers, girders, and secondary steel (diaphragms and their components) are consistent among the systems. The weight due to the barrier rails is assumed to be distributed evenly among all of the girders per AASHTO Article 4.6.2.2.1.

Table 7.3 Unit Weights of the Four Deck Systems

Deck System	Unit Weight (psf)	Unit Weight of Overhang * (psf)
Exodermic Cast-in-Place Deck	73	110
Standard Steel Grid with Cast-in-Place Concrete Topping Deck	88	112
Exodermic Precast	74	113
NCHRP Full-Depth Precast	107	107

* The additional weight of the overhang is due to the additional concrete thickness required in the overhang to resist loads transferred to the deck overhang from a collision with a barrier rail from an errant vehicle.

The live load effects were determined in accordance to AASHTO Article 3.6.1 (AASHTO 2008). Worst case loading was determined at each of the sections of interest

by positioning the axles of the design truck or design tandem to produce extreme load effects. The load contribution by each axle was determined by the use of influence lines.

The bridge widening described in Chapter 4 increases the overall width of the bridge to 46.75 feet. This allows for 3 design lanes per AASHTO Article 3.6.1.1.1 (AASHTO 2008). However, there are currently 2 lanes of traffic per bridge and future changes to this were not considered in this analysis. Therefore, 2 design lanes were used for the live load calculations.

Each girder carries a fraction of the live load. The amount carried by each was obtained by applying distribution factors to the live load force effect. The distribution factors, m_g , were determined in accordance with AASHTO Article 4.6.2.2.2 and are shown in Tables 7.1 and 7.2 (AASHTO 2008). Note in Table 7.2 that the distribution factors for the Exterior girders are all the same. This is due to the lever rule controlling. Similarly, the distribution factors for shear are the same for all of the systems due to the lever rule controlling.

A longitudinal stiffness parameter is required to calculate the moment distribution factors. This stiffness parameter is dependent upon the modulus of elasticity of the material that makes up the deck. The Exodermic and steel grid deck systems have decks that are made up of steel and concrete and are therefore not homogeneous. A modulus of elasticity that will closely represent the stiffness of these deck systems can be estimated by taking a volume fraction of the concrete and the steel and factoring it with the modulus of elasticity for each of the materials. However, there isn't much area of steel in comparison to the concrete deck so the modulus of elasticity of the concrete was conservatively used. The concrete used for the design of these deck systems has a 28-day

compressive strength of 4-ksi, which results in a modulus of elasticity of 3605-ksi. The NCHRP full-depth deck system is designed for a 28-day compressive strength of 6-ksi, but the modulus of elasticity used to calculate the longitudinal stiffness parameter was based on a compressive strength of 4-ksi. This is acceptable because it produces a conservative value for the longitudinal stiffness parameter.

Deflections were calculated and the maximum deflection occurs at mid-span and is equal to the largest value resulting from loading of the design truck alone, or that resulting from 25 percent of the design truck taken together with the design lane load as described in AASHTO Article 3.6.1.3.2 (AASHTO 2008). The cross-section properties without the cover plate were conservatively used to calculate the deflections. Deflections for each of the deck systems are presented and discussed in the next section.

7.3. Performance of Deck-Girder Systems

The nominal moment and shear resistance and corresponding section properties were determined for each of the cross-sections of interest for each of the four deck systems. The nominal moment and shear resistance for each of the deck systems are shown in Table 7.4. The nominal moment capacity for the four deck systems doesn't vary by much. However, the NCHRP full-depth deck system is somewhat stronger than the other systems followed by the steel grid system. The nominal shear capacity is independent of deck properties and is therefore the same for all four of the deck-girder systems. The nominal resistance and plastic neutral axis location was used to determine the design ratios for the Strength I Limit State. The elastic section properties for each of the cross-sections of interest were also calculated. The elastic properties were used to determine

the design ratios for the Service II and the Fatigue Limit States. They were also used to calculate the deflections of the deck-girder systems.

Table 7.4 Summary of Nominal Moment and Shear Resistances of Deck Systems

Deck System	With Cover Plate			No Cover Plate		
	Moment Interior Girder (ft-lbs)	Moment Exterior Girder (ft-lbs)	Shear (lbs)	Moment Interior Girder (ft-lbs)	Moment Exterior Girder (ft-lbs)	Shear (lbs)
Exodermic CIP	4892	4732	383	4247	4090	383
Steel Grid	5024	4922	383	4375	4216	383
Exodermic PC	4892	4732	383	4247	4090	383
NCHRP	5456	5372	383	4566	4502	383

There are several sections along the span that need to be investigated for load resistance. The maximum moment occurs at mid-span and verification of the adequacy of that cross-section must be checked against Strength I and Service II Limit States. The cross-section at the termination of the cover plate is checked due to the change in cross-sectional properties. This section was checked for moment resistance for the Strength I and the Service II Limit States. This cross-section was also checked for shear resistance for the maximum shear at the span ends for the same limit states. Fatigue checks were conducted at the toe of the weld for the cover plate and at the weld on the diaphragm connection plates. The ductility of critical cross-sections was also verified. The design ratios for each case are presented in Table 7.5. A design ratios greater than 1.0 is acceptable. All of the deck systems are ductile and have acceptable design ratios excluding the fatigue resistance of the weld at the cover plate termination. Further investigation of this fatigue detail should be conducted.

Table 7.5 Design Ratios for the Four Deck-Girder Systems

Limit State	Deck System	Exodermic CIP		Steel Grid		Exodermic PC		NCHRP	
	Girder Location	Interior	Exterior	Interior	Exterior	Interior	Exterior	Interior	Exterior
Strength I	Maximum Moment	2.604	2.203	2.608	2.256	2.6	2.196	2.724	2.428
	Moment at Termination of Cover Plate	3.155	2.662	3.168	2.73	3.149	2.654	3.319	2.942
	Maximum Shear	2.312	2.284	2.244	2.257	2.298	2.284	2.18	2.231
Service II	Maximum Moment	2.292	2.111	2.279	2.132	2.286	2.101	2.299	2.231
	Moment at Termination of Cover Plate	2.082	1.912	2.106	1.963	2.075	1.907	2.17	2.096
Fatigue	Toe of Cover Plate Weld	0.515	0.462	0.542	0.482	0.515	0.462	0.592	0.528
	Weld of Diaphragm Connection Plate	4.209	3.941	4.122	3.795	4.209	3.941	3.856	3.515

Deflection control isn't required by AASHTO for the NCHRP full-depth deck system and is left up to the discretion of the owner. The Exodermic and steel grid deck systems must adhere to AASHTO Article 9.5.2 (AASHTO 2008). Even though deflection control of the NCHRP full-depth deck system isn't required by AASHTO, it is included in this study. The limit used for the NCHRP full-depth deck system was the span length, in feet, divided by 800, i.e. $L/800$, as specified by AASHTO Article 2.5.2.6.2 (AASHTO 2008). The same limit was used for the Exodermic and steel grid deck systems as required by AASHTO Article 9.5.2 (AASHTO 2008). Deflection checks were conducted and it was found that the girders for each of the deck-girder systems has a deflection due to live loads that is less than their limit. These results are shown in Table 7.6.

Table 7.6 Summary of Girder Deflections

Deck System	Exodermic CIP		Steel Grid		Exodermic PC		NCHRP	
Girder	Interior	Exterior	Interior	Exterior	Interior	Exterior	Interior	Exterior
Deflection (in)	0.82	0.84	0.75	0.77	0.82	0.84	0.63	0.64
Limit (in)	0.84	0.84	0.84	0.84	0.84	0.84	0.84	0.84

7.4. Shear Stud Requirements

Shear studs are required to provide composite action between the deck systems and their supporting components. The spacing of the shear studs is based on fatigue resistance and is determined in accordance to AASHTO Article 6.10.10.1.2 (AASHTO 2008). The minimum number of studs required is based on the Strength I Limit State and is determined in accordance to AASHTO Article 6.10.10.4 (AASHTO 2008). The shear stud requirements were calculated for the Exodermic, standard steel grid, and the NCHRP full-depth deck systems and the results are summarized in Table 7.7. The variable x in Table 7.7 is the distance from the span ends. A recommended stud configuration is shown in Table 7.8. It should be noted that the configuration in Table 7.8 for the Exodermic and steel grid deck systems are for rows of two 7/8” diameter shear studs while the NCHRP full-depth deck system configuration is for clusters of 1¼” studs.

Table 7.7 Minimum Number of Shear Stud Required

Deck System	Exodermic CIP		Steel Grid		Exodermic PC		NCHRP		
Girder	Interior	Exterior	Interior	Exterior	Interior	Exterior	Interior	Exterior	
Min. No. of Studs per Girder	45	41	57	53	45	41	99	99	
Maximum Pitch (inches)	for x < 5ft	4.78	4.41	4.93	4.98	4.78	4.87	5.64	6.58
	for x > 5ft	5.54	5.11	5.71	5.71	5.54	5.64	6.54	6.58
	for x > 10ft	6.59	6.08	6.79	6.79	6.59	6.71	7.78	7.83
	for x > 15ft	8.14	7.5	8.38	8.38	8.14	8.28	9.60	9.66

Table 7.8 Recommended Shear Stud Configuration

Deck System	Girder	From Span End to 5ft		From 5ft to 10ft		From 10ft to 15ft		From 15ft to Midspan		Total Number of Studs per Girder
		Pitch (in)	No. Studs	Pitch (in)	No. Studs	Pitch (in)	No. Studs	Pitch (in)	No. Studs	
Exodermic CIP	Interior	4.5	28	5.5	22	6.5	18	8	40	216
	Exterior	4	32	5	24	6	20	7.5	42	236
Steel Grid	Interior	4.5	28	5.5	22	6.5	18	8	40	216
	Exterior	4.5	28	5.5	22	6.5	18	8	40	216
Exodermic PC	Interior	4.5	28	5.5	22	6.5	18	8	40	216
	Exterior	4.5	28	5.5	22	6.5	18	8	40	216
NCHRP	Interior	48	16	48	8	48	8	48	32	128
	Exterior	48	16	48	8	48	8	48	32	128

The spacing, or pitch, of the shear studs is dependent upon the number of studs across the girder, the fatigue resistance of each stud, and the fatigue load that is applied. The fatigue load varies along the span with the maximum being at the span ends and the minimum occurring at mid-span. For simplicity, it was assumed that the fatigue load varies linearly from the span ends to mid-span.

The NCHRP full-depth deck system is designed to have the shear studs placed in clusters. The shear stud clusters are spaced at 48 inches and consists of eight 1¼” diameter shear studs. This spacing is larger than the spacing allowed per AASHTO LRFD Bridge Specification. However, validation of the spacing of the shear stud clusters has been done by previous full-scale beam testing as outlined in the NCHRP Report 584. It was concluded that it is okay to use AASHTO Equation 6.10.10.2-1 to “determine the fatigue capacity of studs grouped in clusters and spaced as far as 48 inches” and that “full composite action between precast concrete panels and steel beams can be maintained up to 48 inches of spacing” (NCHRP). The shear stud requirements for the NCHRP full-depth deck system were calculated and it was determined that a minimum of 36 shear

studs are required for both the interior and exterior girders to adhere to the Strength I Limit State requirements. A total of 112 1¼” diameter shear studs are recommended for the 56-foot span by using eight shear studs per cluster and spacing them at 48”. This is well above the minimum number of studs required. The conclusions from the testing described in the NCHRP Report 584 and the investigation of the minimum number of shear studs required for the Strength I Limit State concludes that the design of the NCHRP full-depth deck system shear studs is adequate for use on the I-59 bridges.

7.5. Comparison of the Four Deck-Girder Systems

A normalized comparison of all four of the deck-girder systems is shown in Table 7.9. The normalized values were determined by taking the value for the deck-girder system of interest and dividing it by the largest value of the four deck-girder systems. Therefore, the system with the largest value will have a normalized value of 1.0. The nominal moment capacity and the deflections are compared for an interior girder with a cover plate. The other girders and cross-sections should have similar results. This table shows that the NCHRP full-depth deck system is the heaviest of the four systems, but has the best nominal moment resistance and the smallest deflection. The cast-in-place and the precast Exodermic systems both have about the same values. They are both the lightest, but have the worst nominal resistance and the largest deflection. The steel grid system is somewhere in between. To get a better comparison of the four systems, a normalized value for the moment resistance and the deflection per deck weight was evaluated and is shown in Table 7.9. Viewing these values, it is apparent that the NCHRP full-depth deck system exhibits the best deflection but the worst nominal

moment resistance. The Exodermic cast-in-place and the Exodermic precast deck systems have the worst deflection, but have the best nominal moment resistance. The steel grid deck system falls between the NCHRP full-depth deck system and the Exodermic systems.

Table 7.9 Normalized Comparison of the Deck-Girder Systems

Relative Normalized Parameter \ Deck System	Exodermic CIP	Steel Grid	Exodermic PC	NCHRP
Weight	0.68	0.82	0.69	1.00
Moment Resistance	0.90	0.92	0.90	1.00
Deflection	1.00	0.92	1.00	0.77
Deflection/Weight	1.00	0.76	0.99	0.52
Moment Resistance/Weight	1.00	0.85	0.99	0.76

8. Conclusions and Recommendations

8.1. General

The primary focus of this study was to develop rapid deck replacement schemes to ultimately determine the best option for replacing the deteriorating decks of highly traveled bridges in the Birmingham area. The rapid deck replacement schemes are to be implemented and tested on sister bridges in Collinsville, AL. Four different deck systems capable of rapid replacement were investigated. These were:

- Exodermic steel grid panels with cast-in-place concrete topping
- Standard steel grid panels with cast-in-place concrete topping
- Exodermic steel grid with precast concrete panels
- NCHRP full-depth precast concrete panels

The two cast-in-place (CIP) concrete decking systems are planned for the Collinsville north bound roadway (NBR) bridge. These two systems will require weekend work periods in order to prevent disruption of peak hour traffic due to lengthy cure time for the CIP concrete. The two precast deck panel systems are planned for the Collinsville southbound roadway (SBR) bridge. The deck replacement work using these two systems should be done with overnight, partial lane closure, work periods.

8.2. Conclusions

All four of the deck systems are designed to adequately resist loads that they are subjected to. The four deck systems are also considered ductile and have deflections due to service loads that are within their limits. The deck systems were all designed to have the same overall depth. Providing the same depth allows for a smooth transition between

spans without requiring excessively large haunches. The designs of the Exodermic and steel grid deck systems are somewhat conservative on account of this consideration.

The precast deck systems were designed considering a quarter inch, non-structural, sacrificial layer. This additional thickness provides for surface texturing. Texturing is done by machine grinding and results in a quality-riding surface. Surface texturing the finished deck is recommended since an overlay will not be used.

The barrier rails for all four deck systems will be the ALDOT's standard Jersey barrier that the ALDOT currently uses on new interstate highway bridges. The rails are qualified as TL-4, which is the test rating that is generally used for freeway bridges and will be cast-in-place (CIP) for all four deck systems. The deck overhangs are designed to resist the loads from a vehicle collision with a TL-4 test rated barrier rail.

Composite action between the deck systems and their supporting components is obtained through the use of shear studs. The NCHRP full-depth deck system has shear studs that are grouped in clusters that are spaced at 48 inches. The spacing of the clusters is qualified through previous testing by Badie, et al. as described in Chapter 7. The number of studs and their maximum spacing is shown in Table 7.8 for each of the deck systems.

A requirement to maintain at least one of the existing two traffic lanes open at all times during the deck replacement work required that both sister bridges, i.e., northbound roadway (NBR) and southbound roadway (SBR) bridges be widened during the deck replacement work. The bridge widening requires work to be completed on the substructure as outlined in Chapter 4. Performing the work on the substructure simultaneously with the deck replacement work could hinder the comparability of the

deck systems in regards to the time required to perform the deck replacement work.

Therefore, work on the substructure for both bridges is to be performed before beginning the deck replacement work.

The NBR bridge will be redecked using the CIP Exodermic and CIP standard steel grid deck systems. These were chosen to be installed first because bridge contractors in Alabama are familiar with CIP deck systems. However, to achieve rapid deck replacement, the replacement work must be completed in stages that are completed using Friday night to Monday morning work periods. A high performance concrete mixture that is capable of reaching sufficient strength over the weekend work periods is required for these systems.

The SBR bridge will be redecked using the precast Exodermic deck panels and precast modified NCHRP full-depth deck systems. The replacement work using these systems will also be staged but will use overnight work periods, i.e., 9:00 pm to 6:00 am work periods. This replacement work will require concrete/grout that is very fast setting with very fast strength gaining properties.

To accomplish the above rapid deck replacement using CIP concrete systems and precast concrete panel systems, some rapid-setting and rapid-strength gain concrete and grout mixtures must be developed by the Alabama Department of Transportation (ALDOT). As a starting point, some mixtures used by others have been identified in Chapter 2 and in earlier reports to the ALDOT by Ramey and Oliver, Jacoway and Ramey, and Ramey and Umphrey. These mixtures should be refined by the ALDOT by laboratory testing.

Detailed proposed sequences of staged construction and work-time schedules for both the NBR and SBR bridges are given in Chapter 5.

Each of the four rapid deck replacement panels and elements were designed to act compositely with the supporting girders and were checked for structural adequacy in Chapters 6 and 7 and were found to be satisfactory.

Fatigue resistance was checked for the welds attaching the diaphragm connection plates and the welds attaching the cover plates to the girders. All of the fatigue checks for the welds attaching the diaphragm connection plates are satisfactory. The welds of the cover plates failed the fatigue checks. Further investigation of this fatigue detail should be conducted. It is recommended to not use cover plates on the girders that are to be installed. The load resistance and behavior of the composite cross-sections are adequate for the W36x150 girders without the use of a cover plate. This was determined by expanding on the calculations of Chapter 7.

8.3. Recommendations

The portion of the rapid bridge deck replacement research reported on in this report was focused on the design and constructability of four candidate rapid deck replacement systems as evaluated on paper via analytical and critical analyses. To gain a more complete understanding of the relative merits and demerits of each of the four candidate deck replacement systems, it is recommended that the following actions be taken.

1. Develop concrete/mortar mixture designs for the four rapid deck replacement options with the primary objective of developing rapid setting high performance mixture designs for topping concrete for the CIP deck systems and for closure

pour concrete and/or mortar for the precast deck systems.

2. Prepare final construction documents for the Collinsville, AL sister bridge rapid deck replacements using the four deck systems discussed in this report and award a rapid deck replacement contract to a well qualified bridge construction contractor. To simplify coordination, to help assure consistency in quality of work, and to get consistent feedback from the contractor on the relative merits and demerits of the four deck systems, all of the deck replacement work should be done by the same highly qualified bridge construction contractor.
3. Perform static load tests on the existing Collinsville bridges to evaluate their load-deflection and load-girder strain behaviors at select locations in order to later compare these behaviors with each of the new deck replacement systems. This will also allow comparisons of the four deck replacement systems with each other.
4. Work with ALDOT in developing an effective post construction evaluation process and document to accurately assess the relative “performance” and “productivity” of the four deck systems tested at the Collinsville bridges. The Collinsville bridge deck replacement contractor should be able to assist in the evaluation and provide valuable input.
5. During and following the deck replacement work, document the following for each of the four deck replacement systems:
 - Cost breakdown for the major tasks in the replacement work
 - Time requirements for replacement to include time breakdown for the major tasks in the replacement work

- Traffic control system and traffic disruptions due to replacement work
 - Required lane closure time
 - Design “friendliness” of replacement system
 - Construction “friendliness” of replacement system
 - First year performance
 - The relative ease/difficultly in making deck panel splices in the transverse direction of the bridge (joint/connection between deck panels and between panels and existing deck during staged construction)
 - The relative ease/difficulty in making deck panel splices in the longitudinal direction of the bridge (joint connection between deck panels and existing deck during staged construction)
 - The relative ease/difficulty in handling skewed bridges
 - Any unique positive and negative features associated with the replacement system
6. Have post construction meeting with the deck replacement contractor to get his feedback and evaluation of the construction merits and demerits of the four test deck systems.
 7. Input the information gathered from executing actions cited in numbers 3, 5 and 6 into the developed construction evaluation document cited in number 4 above to analyze and synthesize the results to draw tentative conclusions and recommendations on the best rapid deck replacement system for the Birmingham bridge decks.

References

- AASHTO. "AASHTO LRFD Bridge Design Specifications 4th Edition." Washington, DC, 2007 (with 2008 interim).
- Badie, Sameh S., and Maher K. Tadros. *NCHRP Report 584 - Full-Depth Precast Concrete Bridge Deck Panel Systems*. Washington DC: Transportation Research Board, 2008.
- Barker, Richard M., and Jay A. Puckett. *Design of Highway Bridges an LRFD Approach 2nd Edition*. Hoboken, NJ: John Wiley & Sons, Inc., 2007.
- Beck, Derek, and G. E. Ramey. "Research Project 930-436 - Rapid Rehabilitation/Replacement of Bridge Decks - Phase II Part III - Design, Construction Plans and Cost Estimates for Rapid Replacement of Four GADOT Bridge Decks - Research Project 930-436." Alabama Department of Transportation, Jan. 2005.
- Exodermic Bridge Deck, Inc. "An Introduction to: Exodermic Bridge Decks." 1999.
- FHWA. "FHWA Bridge Rail Memorandum Part 1, 2, & 3." 1997 йил 30-May.
- Koshmatka, S. H., and W. C. Panarese. *Design and Control of Concrete Mixtures Thirteenth Edition*. Stokie, IL: Portland Cement Association, 1988.
- Oliver, Russel S. "Rapid Replacement/Rehabilitation of Bridge Decks." MSCE Thesis, Auburn University, Auburn, AL, 1999.
- Streeter, Donald A. *Developing High-Performance Concrete Mix for New York State Bridge Decks - Transportation Research Record 1532*. Transportation Research Board, Washington D.C.: TRB, National Research Council, 1996, 60-65.

Ramey, G. E., and J. Uphrey. "Rapid Rehabilitation/Replacement of Bridge Decks - Phase II - Part IV Documentation of the Rapid Replacement of Four GDOT Bridge Decks - Transportation Research Record 1532." Alabama Department of Transportation, Jan. 2006.

Ramey, G. E., and R. S. Oliver. "Rapid Rehabilitation/Replacement of Bridge Decks - Research Project 930-376." Alabama Department of Transportation, Nov. 1998.

Ramey, Jacoway B. "Rapid Rehabilitation/Replacement of Bridge Decks - Phase II - Research Project 930-436 Interim Report." Alabama Department of Transportation, Feb. 2003.

Transportation Research Board. "NCHRP Report 350." Washington, DC, 1993.

APPENDIX A

Proposed Barrier Rail Adequacy Check

Proposed Barrier Rail Adequacy Check

ALDOT Standard Barrier Rail:

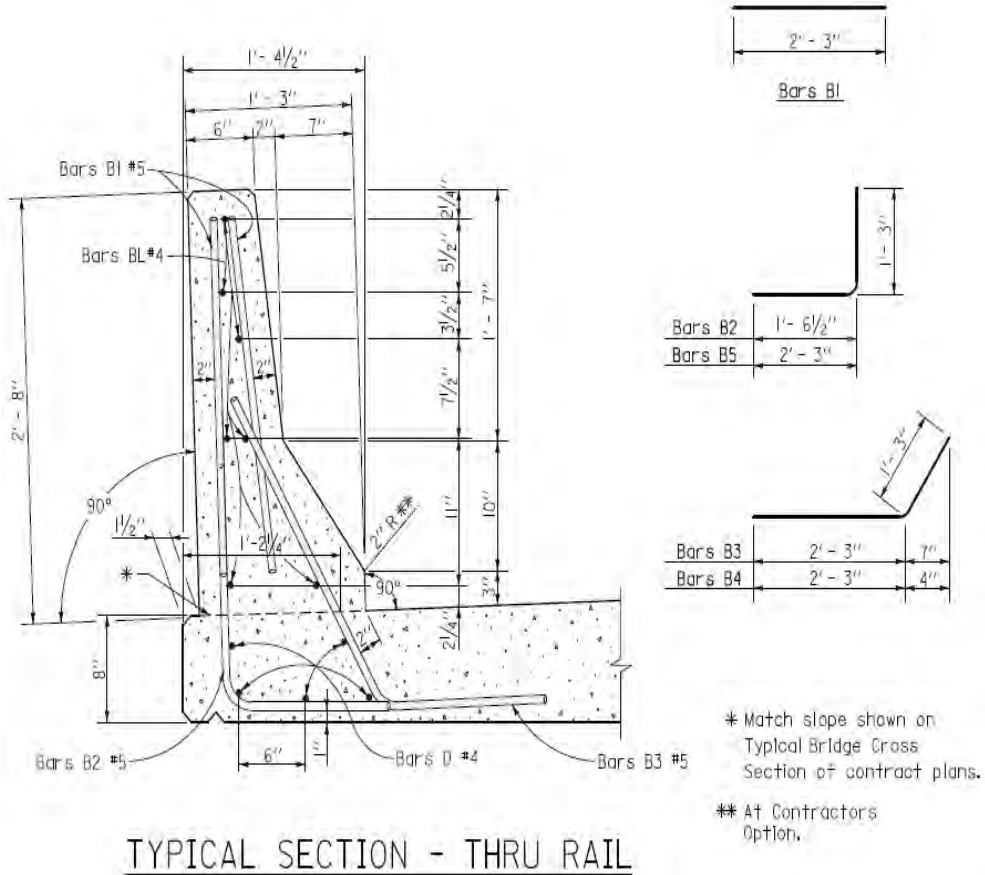

$$P_b := 0.304 \cdot \frac{\text{kip}}{\text{ft}} \quad (\text{barrier weight})$$

$$f_y := 60 \cdot \text{ksi} \quad (\text{yield stress of reinforcing bars})$$

$$f_{\text{primec}} := 4 \cdot \text{ksi} \quad (\text{28 day compressive strength of concrete})$$

$$\phi := 1.0 \quad (\text{Load Resistance Factor - 1.0 for all non-strength limit states, AASHTO C1.3.2.1})$$

$$t_k := 8 \cdot \text{in} \quad (\text{Deck Thickness})$$

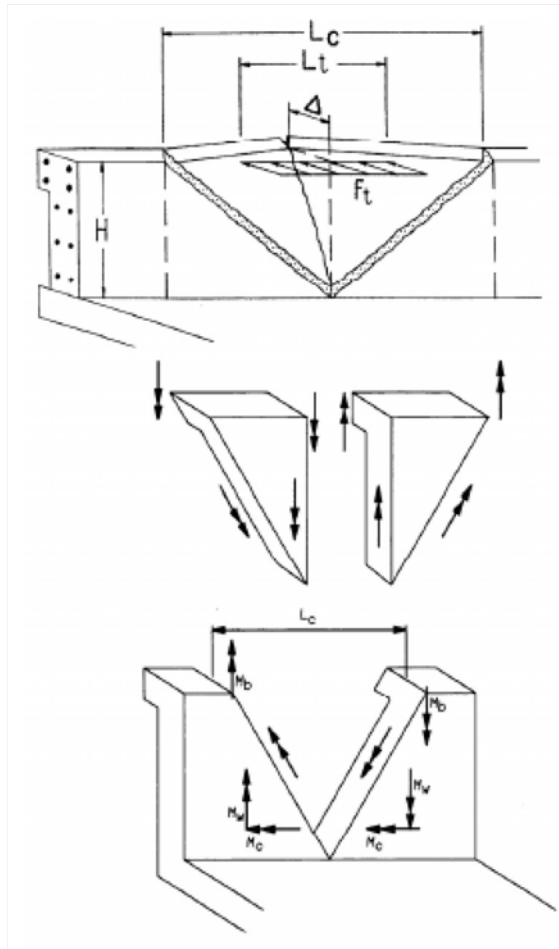

Figure CA13.3.1-1 Yield Line Analysis of Concrete Parapet Walls for Impact within Wall Segment
(From AASHTO Bridge Specification 2007)

1. Flexural Resistance of Barrier About Vertical Axis, Mw

Since the barrier thickness varies, it will be broken into segments for calculation purposes.

The distance to the rebar varies. An average value will be used to simplify calculations.

Both positive and negative moments must be determined since the yield line mechanism develops both. (See Section 7.9 in Barker & Puckett and AASHTO A13.3.1)

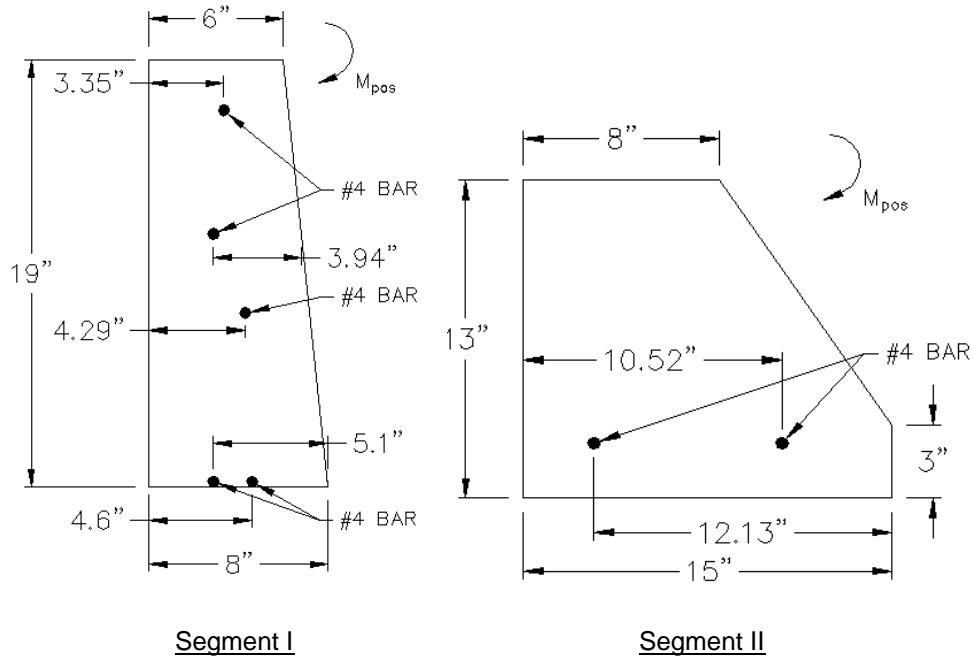

Segment I:

Neglecting contribution of compressive reinforcement

$$b := 19 \cdot \text{in}$$

$$A_{s_{\text{pos}}} := 2 \cdot 0.2 \cdot \text{in}^2 = 0.4 \cdot \text{in}^2 \quad 2 \#4 \text{ Bars}$$

$$d_{\text{avg}_{\text{pos.I}}} := \frac{3.94 \cdot \text{in} + 5.1 \cdot \text{in}}{2} = 4.52 \cdot \text{in}$$

$$a := \frac{A_{s_{\text{pos}}} \cdot f_y}{0.85 \cdot f_{\text{primec}} \cdot b} = 0.372 \cdot \text{in}$$

$$M_{n_{\text{pos}}} := A_{s_{\text{pos}}} \cdot f_y \cdot \left(d_{\text{avg}_{\text{pos.I}}} - \frac{a}{2} \right) = 8.668 \cdot \text{kip} \cdot \text{ft}$$

$$A_{s_{neg}} := 3 \cdot 0.2 \cdot \text{in}^2 = 0.6 \cdot \text{in}^2 \quad 3 \text{ \#4 Bars}$$

$$d_{avg_{neg.I}} := \frac{3.35 \cdot \text{in} + 4.29 \cdot \text{in} + 4.6 \cdot \text{in}}{3} = 4.08 \cdot \text{in}$$

$$a := \frac{A_{s_{neg}} \cdot f_y}{0.85 \cdot f_{primec} \cdot b} = 0.557 \cdot \text{in}$$

$$M_{n_{neg}} := A_{s_{neg}} \cdot f_y \cdot \left(d_{avg_{neg.I}} - \frac{a}{2} \right) = 11.404 \cdot \text{kip} \cdot \text{ft}$$

$$M_{n_I} := \frac{M_{n_{pos}} + M_{n_{neg}}}{2} = 10.036 \cdot \text{kip} \cdot \text{ft}$$

Segment II:

Neglecting contribution of compressive reinforcement

$$b := 13 \cdot \text{in}$$

$$A_{s_{pos}} := 0.2 \cdot \text{in}^2 \quad 1 \text{ \#4 Bar}$$

$$d_{pos.II} := 12.13 \cdot \text{in}$$

$$a := \frac{A_{s_{pos}} \cdot f_y}{0.85 \cdot f_{primec} \cdot b} = 0.271 \cdot \text{in}$$

$$M_{n_{pos}} := A_{s_{pos}} \cdot f_y \cdot \left(d_{pos.II} - \frac{a}{2} \right) = 11.994 \cdot \text{kip} \cdot \text{ft}$$

$$A_{s_{neg}} := 0.2 \cdot \text{in}^2$$

$$d_{neg.II} := 10.52 \cdot \text{in}$$

$$a := \frac{A_{s_{neg}} \cdot f_y}{0.85 \cdot f_{primec} \cdot b} = 0.271 \cdot \text{in}$$

$$M_{n_{neg}} := A_{s_{neg}} \cdot f_y \cdot \left(d_{neg.II} - \frac{a}{2} \right) = 10.384 \cdot \text{kip} \cdot \text{ft}$$

$$M_{n_{II}} := \frac{M_{n_{pos}} + M_{n_{neg}}}{2} = 11.189 \cdot \text{kip} \cdot \text{ft}$$

$$M_w := \phi \cdot M_{n_I} + \phi \cdot M_{n_{II}} = 21.226 \cdot \text{kip} \cdot \text{ft}$$

2. Flexural Resistance of Barrier About Axis Parallel to Longitudinal Axis, M_c

The yield lines that cross the vertical reinforcement only creates tension on the sloped face of the barrier. Because of this, only the negative bending strength will need to be determined.

Neglecting contribution of compressive reinforcement

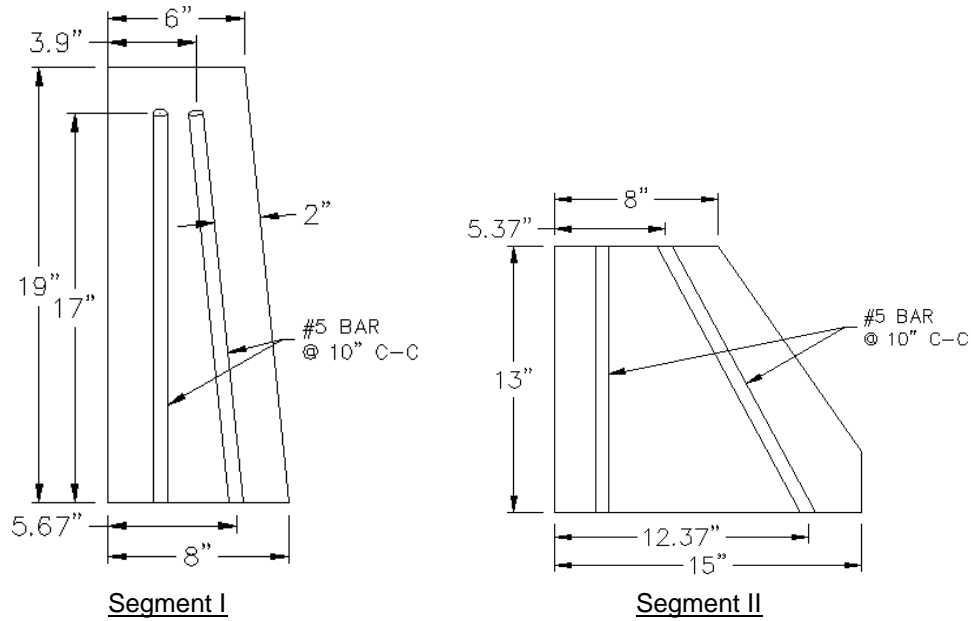

Segment I

$$A_s := 0.372 \cdot \frac{\text{in}^2}{\text{ft}} \quad \#5 \text{ Bars @ } 10" \text{ C-C}$$

Since the depth of the vertical reinforcement varies, an average value will be used.

$$d_{\text{avg.I}} := \frac{3.9 \cdot \text{in} + 5.67 \cdot \text{in}}{2} = 4.785 \cdot \text{in}$$

$$a := \frac{A_s \cdot f_y}{0.85 \cdot f_{\text{primec}}} = 0.547 \cdot \text{in}$$

$$M_{cI} := A_s \cdot f_y \cdot \left(d_{\text{avg.I}} - \frac{a}{2} \right) = 8.391 \cdot \text{kip} \cdot \frac{\text{ft}}{\text{ft}}$$

Segment II

$$A_s := 0.372 \cdot \frac{\text{in}^2}{\text{ft}} \quad \#5 \text{ Bars @ } 10" \text{ C-C}$$

Since the depth of the vertical reinforcement varies, an average value will be used.

$$d_{\text{avg. II}} := \frac{5.37 \cdot \text{in} + 12.37 \cdot \text{in}}{2} = 8.87 \cdot \text{in}$$

$$a := \frac{A_s \cdot f_y}{0.85 \cdot f'_{\text{primec}}} = 0.547 \cdot \text{in}$$

$$M_{\text{c II}} := A_s \cdot f_y \cdot \left(d_{\text{avg. II}} - \frac{a}{2} \right) = 15.989 \cdot \text{kip} \cdot \frac{\text{ft}}{\text{ft}}$$

M_c is determined from a weighted average of $M_{\text{c I}}$ and $M_{\text{c II}}$

$$M_c := \frac{M_{\text{c I}} \cdot 17 \cdot \text{in} + M_{\text{c II}} \cdot 13 \cdot \text{in}}{17 \cdot \text{in} + 13 \cdot \text{in}} = 11.684 \cdot \text{kip} \cdot \frac{\text{ft}}{\text{ft}}$$

3. Critical Length of Yield Line Failure Patter, Lc

$$L_c = \frac{L_t}{2} + \sqrt{\left(\frac{L_t}{2}\right)^2 + \frac{8 \cdot H \cdot (M_b + M_w)}{M_c}} \quad (\text{AASHTO A13.3.1-2})$$

$$L_t := 3.5 \cdot \text{ft} \quad (\text{AASHTO Table A13.2-1, TL-4})$$

$$H := 2.67 \cdot \text{ft} \quad (\text{overall height of barrier rail})$$

$$M_b := 0 \quad (\text{additional flexural resistance of beam})$$

$$L_c := \frac{L_t}{2} + \sqrt{\left(\frac{L_t}{2}\right)^2 + \frac{8 \cdot H \cdot (M_b + M_w)}{M_c}} = 8.22 \cdot \text{ft}$$

4. Nominal Resistance to Transverse Load, R_w

$$F_t := 54.0 \cdot \text{kip} \quad (\text{transverse design force, TL-4 - AASHTO Table A13.2-1})$$

$$R_w := \left(\frac{2}{2 \cdot L_c - L_t}\right) \cdot \left(8 \cdot M_b + 8 \cdot M_w + \frac{M_c \cdot L_c^2}{H}\right) = 71.945 \cdot \text{kip}$$

$$R_w = 71.945 \cdot \text{kip} > F_t = 54 \cdot \text{kip} \quad \text{Okay}$$

5. Determination of Transferred Forces

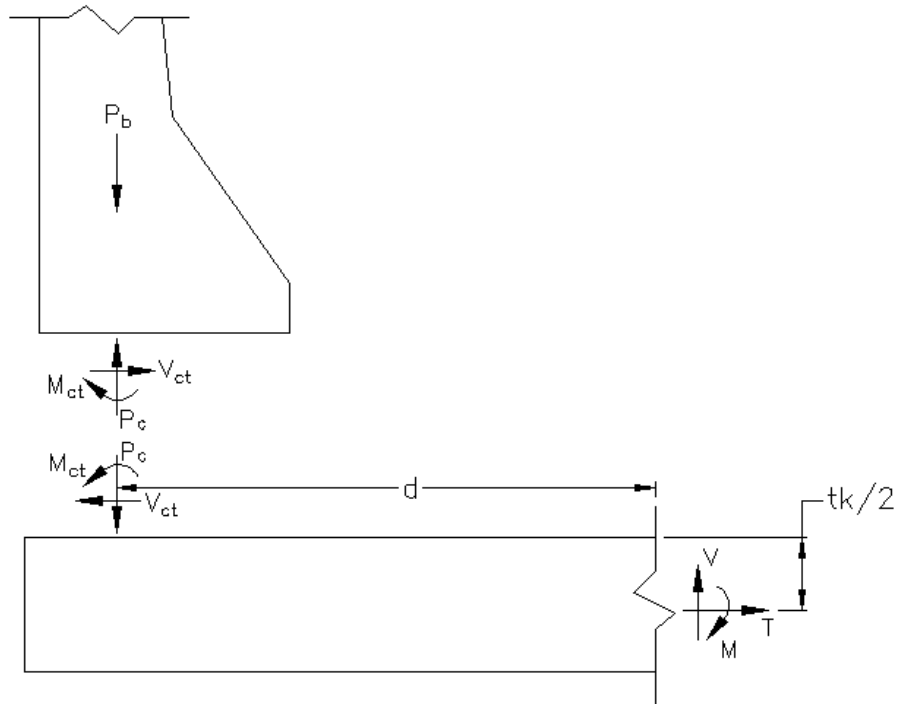

Assuming the center of gravity of the barrier rails is located 3" from the edge of the deck, the distance from the edge of the flange of the exterior girder to the center of gravity of the barrier rail, d , is:

$$d := 3.375 \cdot \text{ft} - \frac{11.975 \cdot \text{in}}{2} \cdot \frac{1 \cdot \text{ft}}{12 \cdot \text{in}} - 3 \cdot \text{in} \cdot \frac{1 \cdot \text{ft}}{12 \cdot \text{in}} = 31.512 \cdot \text{in}$$

$$P_c := P_b = 0.304 \cdot \frac{\text{kip}}{\text{ft}}$$

Assuming R_w spreads out at a 1:1 slope from the top of the barrier. The shear force at the base of the barrier, V_{ct} , is:

$$V_{ct} := \frac{R_w}{L_c + 2 \cdot H} = 5.305 \cdot \frac{\text{kip}}{\text{ft}}$$

$$M_{ct} := -V_{ct} \cdot H = -14.166 \cdot \text{kip} \cdot \frac{\text{ft}}{\text{ft}}$$

$$T := V_{ct} = 5.305 \cdot \frac{\text{kip}}{\text{ft}}$$

$$V := P_c = 0.304 \cdot \frac{\text{kip}}{\text{ft}} \quad (\text{negative shear as shown in figure})$$

$$M := -M_{ct} + P_c \cdot d + V_{ct} \cdot \frac{tk}{2} = 16.732 \cdot \text{kip} \cdot \frac{\text{ft}}{\text{ft}} \quad (\text{negative moment as shown in figure})$$

6. Shear Transfer Between Barrier and Deck

Shear resistance of the interface, V_n (AASHTO 5.8.4)

$$V_n = c \cdot A_{cv} + \mu \cdot (A_{vf} \cdot f_y + P_c)$$

$$< k_1 \cdot f_{primec} \cdot A_{cv}$$

$$< k_2 \cdot A_{cv}$$

A_{cv} is the shear contact area

A_{vf} is the dowel area across shear plane

For concrete placed against a clean surface, free of laitance, but not intentionally roughened: (See AASHTO 5.8.4.3)

$$c := 0.075 \cdot \text{ksi}$$

$$\mu := 0.6$$

$$k_1 := 0.2$$

$$k_2 := 0.8 \cdot \text{ksi}$$

$$b_v := 15 \cdot \text{in} \quad (\text{width of interface})$$

$$A_{cv} := b_v \cdot 12 \cdot \frac{\text{in}}{\text{ft}} = 180 \cdot \frac{\text{in}^2}{\text{ft}}$$

$$A_{vf} := 2 \cdot 0.31 \cdot \text{in}^2 \cdot 12 \cdot \frac{\text{in}}{\text{ft}} \cdot \frac{1}{10 \cdot \text{in}} = 0.744 \cdot \frac{\text{in}^2}{\text{ft}} \quad 2 \text{ \#5 Bars}$$

$$V_n := \min \left[c \cdot A_{cv} + \mu \cdot (A_{vf} \cdot f_y + P_c), k_1 \cdot f_{primec} \cdot A_{cv}, k_2 \cdot A_{cv} \right] = 40.466 \cdot \frac{\text{kip}}{\text{ft}}$$

$$> V_{ct} = 5.305 \cdot \frac{\text{kip}}{\text{ft}} \quad \text{Okay}$$

7. Minimum Area of Steel AASHTO 5.8.4.4

$$A_{vfmin} = \frac{0.05 A_{cv}}{f_y}$$

$$A_{vfmin} := \frac{0.05 \cdot A_{cv}}{\frac{f_y}{\text{ksi}}} = 0.15 \cdot \frac{\text{in}^2}{\text{ft}}$$

$$A_{vf} = 0.744 \cdot \frac{\text{in}^2}{\text{ft}} > A_{vfmin} = 0.15 \cdot \frac{\text{in}^2}{\text{ft}} \quad \text{Okay}$$

8. Development Length AASHTO 5.11.2.4

$$l_{hb} = \frac{38 \cdot \text{db}}{\sqrt{f_{primec}}} \quad l_{hb} := \frac{38 \cdot 0.625 \cdot \text{in}}{\sqrt{\frac{f_{primec}}{\text{ksi}}}} = 11.875 \cdot \text{in}$$

$$l_{dh} := \max(l_{hb}, 8 \cdot 0.625 \cdot \text{in}, 6 \cdot \text{in}) = 11.875 \cdot \text{in}$$

$$l_{dh} < 7 \cdot \text{in} \quad \text{for } 8" \text{ thick deck with } 1" \text{ cover (See AASHTO Figure C5.11.2.4-1)}$$

$$l_{dh} \text{ is larger than } 7", \text{ however, a factor of } A_{s,req}/A_{s,provided} \text{ can be multiplied to } l_{hb}$$

Must determine if excess steel is provided to obtain an $l_{hb} < 7 \cdot \text{in}$

$$l_{dh} \cdot \left(\frac{A_{s,req}}{A_{s,prov}} \right) = l_{dh,req} \quad \text{or} \quad A_{s,req} = A_{s,prov} \cdot \left(\frac{l_{dh,req}}{l_{dh}} \right)$$

$$A_{s,prov} := 0.372 \cdot \frac{\text{in}^2}{\text{ft}}$$

$$A_{s,req} := A_{s,prov} \cdot \frac{7 \cdot \text{in}}{11.875 \cdot \text{in}} = 0.219 \cdot \frac{\text{in}^2}{\text{ft}}$$

Okay if $A_{s,req}$ provides enough strength such that $R_w > F_t$

$$a := \frac{A_{s,req} \cdot f_y}{0.85 \cdot f_{primec}} = 0.322 \cdot \text{in}$$

$$M_{cI,check} := A_{s,req} \cdot f_y \cdot \left(d_{avg,I} - \frac{a}{2} \right) = 5.07 \cdot \text{kip} \cdot \frac{\text{ft}}{\text{ft}}$$

$$d_{avg,I} = 4.785 \cdot \text{in}$$

$$M_{cII,check} := A_{s,req} \cdot f_y \cdot \left(d_{avg,II} - \frac{a}{2} \right) = 9.548 \cdot \text{kip} \cdot \frac{\text{ft}}{\text{ft}}$$

$$d_{avg,II} = 8.87 \cdot \text{in}$$

$$M_{c,check} := \frac{M_{cI,check} \cdot 17 \cdot \text{in} + M_{cII,check} \cdot 13 \cdot \text{in}}{17 \cdot \text{in} + 13 \cdot \text{in}} = 7.01 \cdot \text{kip} \cdot \frac{\text{ft}}{\text{ft}}$$

$$M_w = 21.226 \cdot \text{kip} \cdot \text{ft} \quad (\text{same as before})$$

$$L_{c_check} := \frac{L_t}{2} + \sqrt{\left(\frac{L_t}{2}\right)^2 + \frac{8 \cdot H \cdot (M_b + M_w)}{M_{c_check}}} = 9.98 \cdot \text{ft}$$

$$R_{w_check} := \left(\frac{2}{2 \cdot L_{c_check} - L_t}\right) \cdot \left(8 \cdot M_b + 8 \cdot M_w + \frac{M_{c_check} \cdot L_{c_check}^2}{H}\right) = 52.408 \cdot \text{kip}$$

$$R_{w_check} = 52.408 \cdot \text{kip}$$

This is less than the required resistance of $F_t = 54 \cdot \text{kip}$ or TL-4 rating, but it is close enough.

$$l_{dh} := l_{hb} \cdot \left(\frac{A_{s_req}}{A_{s_prov}}\right) = 7 \cdot \text{in}$$

Assuming anchorage requirements for the hook that isn't 90 degrees is the same as if it was a 90 degree hooks (assuming the pullout results will be the same).

Required minimum bar lengths:

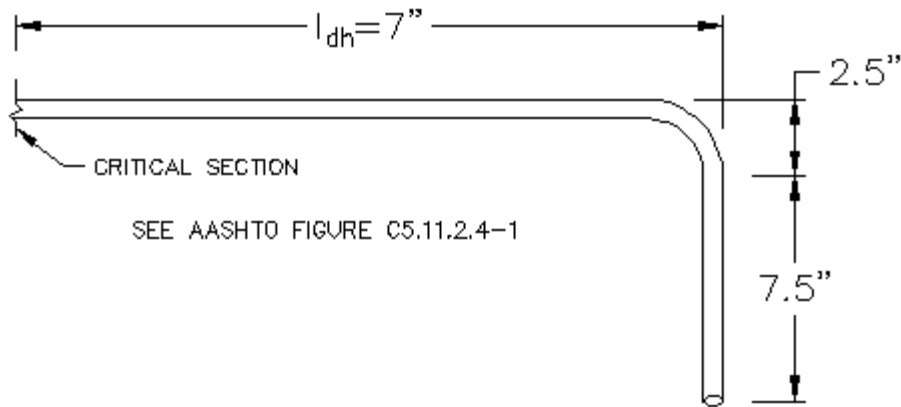

Provided bars are adequate for development

9. References

AASHTO, "AASHTO LRFD Bridge Specifications, 4th Edition", 2008

Barker, Richard M. and Puckett, Jay A. Design of Highway Bridges an LRFD Approach 2nd Edition. Hoboken, New Jersey, 2007.

APPENDIX B

Proposal to AASHTO to Revise Fatigue Requirements for Concrete Filled Steel
Grid Decks

2011 AASHTO BRIDGE COMMITTEE AGENDA ITEM:

SUBJECT: Revision of Fatigue and Fracture Limit State for Concrete Filled Steel Grid Decks

TECHNICAL COMMITTEE: T-14 Steel

<input checked="" type="checkbox"/> REVISION	<input checked="" type="checkbox"/> ADDITION	<input type="checkbox"/> NEW DOCUMENT
<input checked="" type="checkbox"/> DESIGN SPEC	<input type="checkbox"/> CONSTRUCTION SPEC	<input type="checkbox"/> MOVABLE SPEC
<input type="checkbox"/> MANUAL FOR BRIDGE EVALUATION	<input type="checkbox"/> SEISMIC GUIDE SPEC	<input type="checkbox"/> COASTAL GUIDE SPEC
	<input type="checkbox"/> OTHER	

DATE PREPARED: November 1, 2010

DATE REVISED:

AGENDA ITEM:

Modify the second and third paragraphs of Article 9.5.3 – Fatigue and Fracture Limit State of the AASHTO LRFD Bridge Design Specifications to the following:

Open grid, filled grid, partially filled grid and unfilled grid decks composite with reinforced concrete slabs shall comply with the provisions of Article 4.6.2.1, Article 6.5.3, and Article 9.8.2.

Steel orthotropic decks shall comply with the provisions of Article 6.5.3. Aluminum decks shall comply with the provisions of Article 7.6.

OTHER AFFECTED ARTICLES:

Item #1

Modify the first paragraph of Article 9.8.2.3.3 – Fatigue and Fracture Limit State of the AASHTO LRFD Bridge Design Specification to the following:

The internal connection among the elements of the steel grid in a fully-filled grid deck need not be investigated for fatigue in the negative moment region when the deck is designed with a continuity factor of 1.0. For a partially filled grid, the internal connection among the elements of the steel grid within the concrete fill need not be investigated for fatigue in the negative moment region when the deck is designed with a continuity factor of 1.0.

Item #2

Delete the second paragraph of Article 9.8.2.3.3 – Fatigue and Fracture Limit State of the AASHTO LRFD Bridge Design Specification addressing tack welds on form pans.

Item #3

Insert the following paragraph into the Commentary for Article 9.8.2.3.3.

Fully-filled and partially-filled steel grid decks must be checked for fatigue in only the positive moment region (mid span). However the fatigue moment should be calculated for a simple span configuration (C=1.0) regardless of the actual span configuration.

BACKGROUND:

The first edition of the AASHTO LRFD Bridge Design Specification and all revisions up to 2003 did not require fatigue design checks on internal connections (within the concrete fill) of fully-filled and partially-filled steel grid decks. However in the 2003 Interims, modifications were made which required these internal connections to be designed for fatigue which results in maximum design span lengths much lower than historical limits.

To investigate this discrepancy a calibration study was performed using 26 in-service decks (16 full depth grid and 10 partial depth grid) with at least 10 years of service history [Higgins, 2009]. The study concluded that live load moments based on orthotropic plate theory from Article 4.6.2.1.8 of the AASHTO code are consistent with conventional concrete deck live load demands and therefore no change is required to the force effects. While strength resistance, deflection resistance, and fatigue resistance in positive moment regions on the grid deck yield allowable span lengths consistent with the 26 projects studied, fatigue resistance in the negative moment region greatly reduce allowable span lengths. An example of these span reductions are illustrated below.

Bridge	Mackinac	I-70 over MO River	Upper Buckeye
Deck Type	Full Depth	Partial Depth	Partial Depth
LRFD Span	1.6'	0.6'	1.3'
Actual Span	5.0'	7.1'	8.25'
Years in Service	52	30	15

ANTICIPATED EFFECT ON BRIDGES:

Implementation of the revised specification will allow fully-filled and partially-filled steel grid decks to be designed for span lengths consistent with historical limits.

REFERENCES:

“Calibration of AASHTO-LRFD Section 4.6.2.1.8 with Historical Performance of Filled, Partially Filled, Unfilled and Composite Grid Decks – Final Report”, Christopher Higgins, O. Tugrul Turan, School of Civil and Construction Engineering, Oregon State University, Corvallis, OR, 97331, June 2009

OTHER:

None

APPENDIX C

Recommended Special Provisions to the Alabama Standard Specifications for
the Rapid Deck Replacement on Sister I-59 Bridges at Collinsville, AL

The following is a composite of,

1. Special Provisions first draft prepared by the ALDOT.
2. Added material, changes and comments to No.1 above (so indicated by | ADD or | CHANGE or BOXED comments) prepared by Auburn Researchers.
3. Select Special Provisions extracted from GDOT Special Provisions for rapid deck replacement of two 1-285 bridges in Atlanta, GA.
4. Other Special Provisions deemed appropriate by the AU research team.

ALABAMA DEPARTMENT OF TRANSPORTATION

DATE: December 9, 2010

Special Provision No. OS-OXXX

SUBJECT: Bridge Deck Replacement Systems, Project No. BR-1059(???),
DeKalb County.

Alabama Standard Specifications, 2008 Edition, shall be amended by the addition
of SECTION 518 as follows:

SECTION 518 BRIDGE DECK REPLACEMENT SYSTEMS

518.01 Description.

This Section shall cover the work of constructing bridge decks. The bridge decks shall be constructed with the bridge deck systems shown on the plans.

Bridge deck systems *are* being required to allow the construction of the bridge decks to be done in a timely manner.

518.02 Materials

(a) General

All materials shall be furnished in accordance with the material requirements shown on the plans or given in the contractor's submittal of the design and details of the bridge deck systems. The material requirements shall be those given in these Specifications for the type of material required unless shown otherwise on the plans or submittal.

(b) Concrete

Due to the rapid deck replacement nature of this project, special demands or requirements will exist for the concrete materials needed in executing the Collinsville All redecking work as indicated in Table 1. For the CIP concrete deck test systems (the SBR Bridge), the concrete aggregate must be smaller (1/2" max or # 7 stone max) and it must gain strength very rapidly (see Table 1). For the precast concrete deck test systems, (the NBR Bridge), the closure pour concrete must have small aggregate and gain strength even more rapidly than that used on the NBR Bridge (see Table 1.)

ADD

Table 1
Collinsville, AL Rapid Deck Replacement Concrete Mixture
Locations and Required Properties

Mixture ID	Location Where Used	Properties
C-BR (Barrier rail concrete)	CIP Barrier Rails for both NBR & SBR Bridges	High quality see with compressive strength greater than 3000 psi in 24-hours after placement and $f_{ie} > 4000$ psi or, CNO concrete (see below)
C-ND (NBR deck concrete)	NBR deck concrete to be CIP in Exodermic and Standard Grid Steel Panels	High quality concrete with low shrinkage, low-permeability, and a compressive strength greater than 3000 psi in 24-hours after placement and $f_{ie} > 4000$ psi
C-SD1 (SBR deck concrete)	SBR deck concrete to be precast in the Exodermic and Modified NCHRP Panels	High quality concrete with low shrinkage, low permeability, and $f_{ie} > 4000$ psi
C-SD2 (SBR deck closure pour concrete)	SBR deck closure pour concrete to be field placed in deck longitudinal joints and/or in panel shear pockets over girders and in deck transverse joints between precast panels wherever possible	High quality concrete with low shrinkage, low permeability, and a compressive strength greater than 3000 psi in 2-hours after placement and $f_{ie} > 4000$ psi
G-SO (SBR grout)	SBR grout for use in transverse joints between precast deck panels and for injecting in NCHRP panel shear pockets over bridge girders if needed in lieu of using C-S02 mixture	High quality grout with low shrinkage, low permeability, and a compressive strength greater than 3000 psi in 2-hours after placement and $f_{ie} > 4000$ psi

ADD

518.0.3 Construction Requirements.

a) BRIDGE DECK SYSTEM DETAILS SHOWN ON THE DEPARTMENT'S PLANS.

The bridge deck system details shown on the plans are schematic details that are given to identify the requirements for the basic size and installation requirements for each bridge deck system.

The Contractor shall be responsible for designing, furnishing and installing the bridge deck systems based on the schematic details shown on the plans.

b) BRIDGE DECK TEST SYSTEMS

1. System 1: Exodermic Steel Grid with Cast-in-Place Concrete (NBR Bridge)

This system shall be supplied from the following companies:

-The Exodermic Steel Grid from Baily Bridges Inc.

Contact: Gene Gilmore
(256) 845-7575

- Exodermic panel placement, leveling/alignment, placement, finishing and curing of CIP concrete by the project construction contractor.

2. System 2: Standard Steel Grid with Cast-in-Place-Concrete (NBR Bridge)

This system shall be supplied from the following companies:

- The Standard Steel Grid from LB Foster Co.

Contact: Mike Riley
(412) 928-_____

- Grid panel placement, leveling/alignment, placement, finishing and curing of CIP concrete by the project construction contractor.

3. System 3: Exodennic Steel Grid with Precast Concrete Panels (SBR Bridge)

This system shall be supplied from the following companies:

- The Exodermic Steel Grid Panels from Bailey Bridges Inc.

Contact: Gene Gilmore
(256) 845-7575

- Precasting concrete on the Exodermic steel panels by Hanson Prestress Co.

Contact: Johnnie Hayes
() _____

- Precast Exodermic panel placement, leveling/alignment, closure concrete pours by the project construction contractor.

4. System 4: Precast Prestressed Concrete Panels (SBR Bridge)

This system shall be supplied from the following companies:

- The precast prestressed concrete panels from Hanson Prestress Co.

Contact: Johnnie Hayes
() _____

- Precast prestressed panel placement, leveling/alignment, closure concrete pours by the project construction contractor.

ADD

(c) SUBMITTAL OF DESIGNS, SPECIFICATIONS, DETAILS AND INSTALLATION PROCEDURES.

1. PURPOSE OF SUBMITTAL.

The Contractor shall submit the designs, specifications, details and installation procedures for each of the bridge deck systems. This submittal shall be a supplement to the Department's plans and specifications to provide all of the information that is required for the construction of bridge decks that will meet the required loading capacity and geometric requirements. The designs, specifications, details, and installation procedures shall be complete to the point that all required materials are identified, all structural features are adequately described and dimensioned, and all installation procedures are thoroughly described.

2. DESIGN REQUIREMENTS.

The bridge deck systems shall be designed using the Service Load Design Method to carry HS20 loading in accordance with the current edition of the AASHTO Standard Specifications for Highway Bridges.

Design computation shall be submitted in duplicate. Each set of design computations shall be prepared, stamped, dated and signed by a Professional Engineer registered in the State of Alabama, and not employed by the State of Alabama. The design computations shall address all members, connections, and anchorage. The designer shall note on the design computations where the design of each member meets the design requirements and reflection tolerances.

Design computations shall include all formulas used and a copy of all calculations and computer printouts that cover all members, connections, and details necessary for complete bridge deck structure designs for all bridge deck systems. Where computer-generated designs are used, the printouts shall consist of the applied loadings, structure geometry, component sizes, moments, shears, reactions, component forces, component stresses, allowable component stresses, combined stress ratios, and deflections. The method of solution used by the computer program, including all formulas used, shall be submitted.

3. SPECIFICATIONS.

References shall be given to other Sections of these Standard Specifications where they are applicable to the material, fabrication and installation requirements for the bridge deck systems. The Contractor shall submit all other specifications that are required to completely identify the material, fabrication and installation requirements for the bridge deck systems.

4. DETAILS.

Details of the bridge deck systems shall be submitted on 22" x 34" size plan sheets. Plan, elevation and cross sectional views shall be shown on the drawings to completely identify the sizes, placement and connection details of all components of the bridge deck systems.

5. INSTALLATION PROCEDURES.

The installation procedures shall be submitted for all sequences of installation, formwork, and falsework for the bridge deck systems.

6. INITIAL SUBMITTAL.

The Contractor shall submit 3 sets of the designs, specifications, details and installation procedures for the bridge deck systems to the Construction Engineer as an initial submittal. This submittal shall be made within 30 calendar days after the date of the "Notice to Proceed".

If clarifications are required, one set will be returned to the Contractor with comments for clarification. The initial submittal will be returned to the Contractor for clarification within 14 calendar days after the receipt of the initial submittal.

The Contractor will be allowed 7 calendar days for each clarification of the initial submittal and the Construction Engineer will be allowed 7 calendar days to determine if further clarification is necessary.

The Materials and Tests Engineer will not approve the submittal of design calculations and Wall Construction Drawings but will review the submittal for completeness.

The initial submittal of the design calculations and Wall Construction Drawings shall be

Bridge

Bridge

DRAFT

sealed by a Licensed Professional Engineer licensed in the State of Alabama.

7. FINAL SUBMITTAL.

When the Construction Engineer informs the Contractor that the design calculations and bridge deck system details are complete, the Contractor shall submit 5 sets of calculations and drawings and a Mylar sepia set of the drawings as a final submittal. The Contractor will be allowed 5 calendar days to make the final submittal.

The Contractor shall not begin the construction of the bridge deck systems or incorporate materials into the work until the Construction Engineer returns one set of the completed design calculations and bridge deck system details to the Contractor.

The final submittal of the design calculations and bridge deck system details shall be sealed by a Licensed Professional Engineer licensed in the State of Alabama.

d) CONCRETE PLACEMENT, CURING AND FINISHING.

Concrete shall be placed, finished and cured in accordance with the requirements given in Sections 501 and 510. The riding surface of the bridge decks shall be a saw cut grooved finish in accordance with the requirements given in Section 510.

A. Video Surveillance of Construction using Construction Cameras (CC)

Place the CCs at the locations directed by the Auburn University rapid bridge deck replacement (RBDR) research team. Ensure that a designated representative familiar with the operation and programming of the unit is available on the Project for initial installation. Repair or replace malfunctioning CCs within 12 hours of notification by the RBDR research team.

Provide a system that includes a fixed camera with remotely controllable digital Pan, Tilt and 5x Zoom (PTZ), and viewable over the internet through a password protected website. Provide for internet access through the website hosted by EarthCam with 24/7 monitoring. EarthCam must maintain camera information on their own locally controlled server. No substitution is permitted. Provide broadband communication service and On-Site Camera Configuration for remote operation and control from the web site to the field site. Provide continuous viewable image at a minimum of 2816H x 2112V resolution and 1 image per 15 minutes (fpm) through the web site. Camera web interface must provide a markup tool to leave notes on images. Interface must provide a calendar of past camera images. Provide any incidental equipment or material required for successful remote operation and communications. Representative of the Department and the Research Team should be granted access to continuously access the EarthCam website to view and monitor construction progress throughout the duration of the project.

Provide remote operating capability of the CCs during all work activity involved in the Project including construction operations, lane or shoulder closures, or other impacts to traffic. Contractor shall provide the Department and the Research Team with a complete time lapse video of total construction effort at Project completion. **[518.04 Method of Measurement.]**

The bridge decks will be measured per square yard of bridge deck surface and the area at the top of the bridge deck that is supporting the permanent barrier rail. Measurement will be made to the nearest tenth of a square yard.

518.05 Basis of Payment.

(a) UNIT PROCE COVERAGE.

The bridge decks will be paid for at the contract unit price bid per square yard which shall be full compensation for all submittals, materials, equipment, tools, labor, and incidentals necessary to complete this item of work.

(b) PAYMENT WILL BE MADE UNDER ITEM NO.

529-A Bridge Deck System *_ - per square foot

* 1, 2, 3, 4, etc.

TIME PROVISIONS

This needs to be changed as it would be too time consuming to use on Collinsville Project.

Hard return

DRAFT

Special provisions need to be established to put time provisions on construction of each deck system in Collinsville when experimenting with accelerated construction efforts. This will help ensure the schedules associated with each deck system are comparable so a proper evaluation can be performed. On a typical accelerated construction effort, contracts would have penalties for extended lane closures or lane rental fees.

Also, we may need to address provisions for allowing pauses in construction for researcher inspection without penalizing the contractor.

DRAFT

Section 150 - Traffic Control

- A. For this project, the advance warnings signs specified in Subsection 150.03.H shall be in place only during times that construction is in progress or as conditions warrant as directed by the Engineer. Signs shall be removed or covered at all other times.
- B. Traffic Flow and directions and sequence of construction for the Collinsville I-59 rapid bridge deck replacement work are shown in Fig. 1 below.

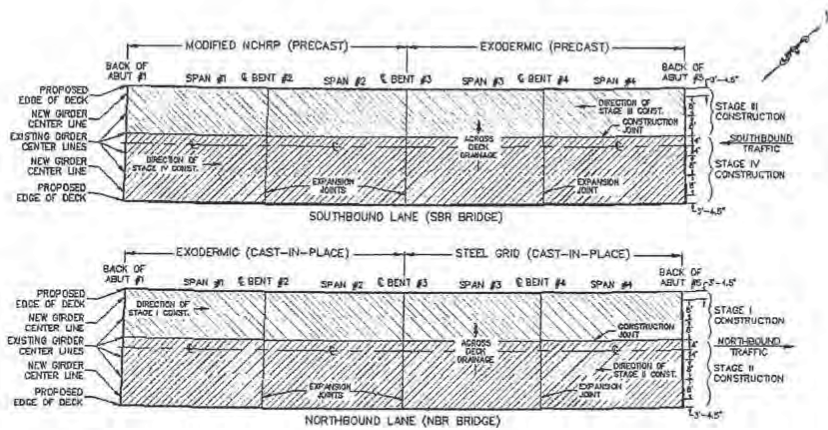

Fig. 1. Plan View of Collinsville I-59 Bridges Showing Sequence of Construction

C. Following Special Conditions apply:

- 1. NBR Bridge (see Fig. 1 above)
 - a. Work shall progress in the direction of traffic for Stage I construction (replacing the inside lane of deck)
 - b. Work shall progress in the direction opposing traffic for Stage II construction (replacing the outside lane deck)
 - c. The NBR Bridge will be a 1-traffic lane bridge throughout Stage I construction
 - d. Steel diaphragm work shall be completed prior to beginning deck replacement and edge beam work

- e. Deck replacement work shall be completed linearly from Span #1 to Span #4 using a 7 -day work week as needed during Stage I construction.
 - f. Stage I construction which includes placing the new CIP barrier rail on the north side of the NBR bridge shall be completed and ready for traffic before beginning Stage II construction.
 - g. Only minimal lane closures will be allowed on SR68 (under the I-59 bridges) as viewed necessary by the State Bridge Engineer.
 - h. Stage II construction shall begin immediately upon completion of the Stage I work and shall progress in a linear manner in the direction opposing traffic as indicated in Fig. 1.
 - i. Deck replacement and edge beam work during Stage II is allowed from 9:00 PM Friday until 6:00 AM Monday. Saw-cutting for deck removal, grinding, joint sealing", permanent striping, temporary striping for traffic shifts, bearing repair and painting will be allowed from 9:00 PM to 6:00 AM, Monday through Sunday. Deck replacement should be for 1-span each weekend during the Stage II work.
 - j. The CIP barrier rails on the south side of the NBR bridge can be placed (behind the temporary barrier rails) during regular work hours as each spans CIP concrete deck gains sufficient strength.
 - k. The temporary barrier rails should be removed as soon as the deck has been replaced on all four spans, and the new CIP barrier rails have gained sufficient strength.
 - l. All work on the NBR bridge shall be completed using a maximum of six (6) weekend partial-closures on the interstate.
 - m. Work on this bridge shall be completed and both lanes opened to traffic prior to beginning deck replacement work on the SBR bridge.
2. SBR Bridge (See Fig. 1 above)
- a. Work shall progress in the direction of traffic for Stage III construction (replacing the outside lane of deck)
 - b. Work shall progress in the direction opposing traffic for Stage IV construction (replacing the inside lane deck)
 - c. The SBR Bridge will be a 1-traffic lane bridge throughout Stage III construction.
 - d. Steel diaphragm work shall be completed prior to beginning deck replacement and edge beam work.
 - e. Deck replacement work shall be completed linearly from Span #4 to Span #1 using a 7 -day work week as needed during Stage III construction.

- f. Stage III construction which includes placing the new CIP barrier rail on the north side of the SBR bridge shall be completed and ready for traffic before beginning Stage IV construction.
 - g. Only minimal lane closures will be allowed on SR68 (under the I-59 bridges) as viewed necessary by the State Bridge Engineer.
 - h. Stage IV deck replacement progress may be somewhat constrained to allow for the evaluation of deck joints under traffic conditions
 - i. Stage IV construction shall begin immediately upon completion of the Stage III work and shall progress in a linear manner in the direction opposing traffic as indicated in Fig. 1.
 - j. Deck replacement and edge beam work during Stage IV is allowed from 9:00 PM to 6:00 AM, Monday through Sunday. Saw-cutting for deck removal, grinding, joint sealing, permanent striping, temporary striping for traffic shifts, bearing repair and painting will be allowed from 9:00 PM to 6:00 AM, Monday through Sunday.
 - k. The CIP barrier rails on the south side of the SBR bridge can be placed (behind the temporary barrier rails) during regular work hours.
 - l. The temporary barrier rails should be removed as soon as the deck has been replaced on all four spans, and the new CIP barrier rails have gained sufficient strength.
 - m. All work on the NBR bridge shall be completed using a maximum of sixteen (16) night-time partial-closures on the interstate.
 - n. Co-polymer deck overlay installation must be completed within 30 days after the deck replacement and edge beam work is complete on the SBR bridge.
3. Work zone law enforcement shall be required during lane closures for staging and traffic shifts.
 4. Failure to meet the set completion time will result in liquidation damages in accordance with Special Provision Subsection 108.08.
 5. A minimum concrete strength of 3500 psi is required for the closure pours of the precast deck panels on the SBR Bridge prior to opening the closed lanes to traffic. If necessary, the contractor shall make modification to the specified concrete class mix as allowed by the specification to obtain the strength necessary to meet the required schedule.
 6. The Contractor shall submit a work plan that shows how the work will be accomplished within the specified work time. Standby equipment shall be provided to ensure the completion of the work by the specified time.

7. The Contractor shall provide extra lighting for night-time work (lighting beyond the minimum required) on both the NBR and SBR bridges in order to achieve good quality night work results and to achieve good quality Camcord recordings of the night-time work. Cost for the extra lighting will be paid for under Pay Item XXXX.
- D. The Contractor shall request, in writing, the Engineers approval for any shifts, change, or restrictions to traffic through the project at least 14 days prior to the anticipated traffic control work. Upon approval, the Engineer shall notify the Public Affairs Office of the ALDOT at least five (5) days prior to each shift, change, or restriction of traffic. Also, the Engineer shall notify the DOT Permits Office fourteen (14) days prior to the lane closures to enable them to detour overwidth loads. Permits shall also be notified when work is interrupted or completed. Notification of beginning and ending work is mandatory to keep overwidth load detours to a minimum.
 - E. The Contractor shall provide six (6) changeable message signs for use as needed. Cost for changeable message signs shall be paid for under Pay Item 632-0003 Variable Message Sign, Portable, Type 3. The Contractor shall also provide as dictated by field conditions, sequential flashing arrow signs in accordance with Special Provision 150 as included in the contract, applicable Alabama Standards and MUTCD.

Section 108 - Prosecution and Progress

C. Intermediate Completion Schedule

An overall Completion Date is established for this Project. However, it is necessary to complete certain portions of The Work at an earlier time. A separate completion time is specified for those portions of the work that require closing of lanes/roadway as specified in Subsection 150.11.

For this Project, restricted work hours are required. Lanes may be closed in accordance with Special Provision 150.11, Traffic Control, Paragraph B C

Failure to reopen lanes of traffic closed for staging and traffic shifts by the times specified in Paragraph B C ~~through B~~ will result in the assessment of Liquidated Damages at a rate of \$10,000.00 per hour or portion of an hour.

Failure to place or remove detour message and requested message changes on a message board within the time frame specified in Special Provision 150.44 will result in the assessment of Liquidated Damages at a rate of \$500.00 per occurrence per message board.

This rate is cumulative and in addition to the Liquidated Damages which may be assessed in accordance with Subsection 108.08 for failure to complete the overall project on time.

SECTION 505 - COMPOSITE STEEL GRID DECK WITH PRECAST CONCRETE SLAB

505.1 General Description

This work consists of furnishing and installing of pre-fabricated structural steel grid deck composite with a reinforced concrete deck slab. Furnish all materials, tools, equipment, transportation, necessary storage, access, labor and supervision required for the proper installation of the deck system",

505.1.03 Submittal Requirements

Submit for review by the Engineer, complete shop drawings, design calculations, and product data that includes the information listed below. Submit seven (7) complete sets of information. Five (5) sets are to be set to the Office of Bridge Maintenance and the remaining two (2) sets to the Area Engineer.

- C. Product data information for the proposed including the following:
1. Certification from the system manufacturer of the material and section properties of the deck system.
 2. Written verification from the system manufacturer that the installers have received the required certifications and training to install the deck system.

Approval of the above by the Engineer does not relieve the Manufacturer and Contractor of responsibility for the performance of the deck system used.

505.1.04 Contractor Qualifications

Submit to the Engineer for approval, written verification from the Manufacturer proving past experience or training in the installation of the manufacturer's system. Provide quality control procedures in compliance with the Manufacturer's installation requirements for the deck system. Employ or retain for the duration of the contract a full-time on-site Project Manager with technical knowledge of deck system that has successfully completed three (3) installations on similar deck replacement projects. The Project Manager is to be on-site at all times during installation of the panels. The Project Manager is to attend the Pre-Construction Conference and provide a demonstration or presentation on the deck system to the Department. Submit the following information to the Engineer for review and approval 30 days prior to beginning work on the project:

- A. Proof of certification by the Manufacturer.
- B. Proof of five (5) year Manufacturer's warranty.
- C. Resume of proposed Project Manager.
- D. A list of three (3) deck replacement projects completed by the Project Manager, including the dates of work, type, description and amount of work performed, and the name and telephone number of a contact person at the agency or company for which the work was completed.

The engineer of record reserves the right to approve or reject the personnel qualifications as submitted. The engineer may suspend the work if the contractor substitutes unauthorized personnel for authorized personnel during construction

505.2 Materials

505.2.01 Delivery, Storage, and Handling

Deliver panels to the job site free from any defects and bearing the proper identifying marks. The completed panels shall be marked with their proper identification number. Stack panels no more than four (4) high during shipment and storage. Store and ship panels right-side up. Provide wood blocking between deck panels during transportation and storage (giving special consideration to built-in panel camber), in order to avoid distortion and to prevent damage to steel, concrete, sheet metal, or galvanized coating, giving special consideration to built-in panel camber.

505.2.02 Steel Grid Decking

Fabricate steel grid to the dimensions and properties as shown on the plans, shop drawings, and in accordance with the Specifications. Provide weld sizes in accordance with established grid industry practice unless otherwise indicated on the contract plans.

Fabricate the grid with dimensional tolerances in accordance with the most recently published standards of the Bridge Grid Flooring Manufacturers Association.

After the attachment of edge bars, leveling devices, vertical form pans, and other components as described in the plans and specifications, galvanize the entire steel grid in accordance with ASTM A123. Repair any defects in galvanizing as specified in Standard Specifications Section 645.

Unless specified otherwise, provide leveling bolts, nuts, and washers in accordance with ASTM A307. If minimum top cover over the leveling bolts is less than or equal to 2.5 inches, provide galvanized leveling bolts.

Provide vertical steel sheet metal form pans, installed in the grid prior to galvanizing, conforming to ASTM 366. Furnish steel sheet metal forms, installed following grid panel galvanizing, in the gauge specified on the contract drawings and galvanized in accordance with ASTM A653. Protect all metal forms during shipment and site storage to retain their shape until deck panel installation.

Steel grid deck manufacturers considered for use under this specification are listed below. Only systems generally consisting of precast concrete deck composite with prefabricated steel grid decks are considered acceptable for this project. Substitutions or alternate designs using cast-in-place decks are not allowed.

Manufacturer

American Bridge Manufacturing
2000 American Bridge Way
Coraopolis, PA 15108
Tel: 412-631-3040
Fax: 412-631-4001

D.S. Brown Company
300 East Cherry Street
North Baltimore, OR 45872
Tel: 419-257-3561
Fax: 419-257-2200

L.B. Foster Company
1016 Greentree Road
Pittsburgh, PA 15220
Tel: 412-928-3548
Fax: 412-928-3514

All requirements for materials defined in this Special Provision must be met prior to final approval for installation.

505.2.03 Precast Concrete

Provide deck with Class AAA concrete in accordance with Section 500 of the Standard Specifications. Furnish concrete deck with a minimum 28-day compressive strength of 4000 psi, design slump between 2" and 4", maximum water cement ratio of 0.40 and a maximum coarse aggregate size of 0.375". Provide deck with a minimum of ¼ " additional concrete overfill to be milled off after all panels are installed. Cure precast panels using we(cure methods a minimum of one week. Do not remove panels from the forms until the concrete has reached 75% of the design strength. After curing, remove all form release material and any other forming materials adhering to the shear key and block out concrete. Sandblast shear key faces , with care taken to avoid damage to the galvanized coating. any

Furnish deck reinforcing steel in the accordance with Section 511 of the Standard Specifications. Place rebar with due consideration to the location of the leveling bolts, providing sufficient clearance for adjustment of the leveling bolts from above using a socket wrench, as well as for clearances required for field placement of headed shear studs. Place main (top) rebar, which runs in the same direction as the main bearing bars of the steel grid, a minimum of 1" from the web of the main bearing bars. Provide a minimum cover between rebar and exposed surfaces of precast concrete of 1" unless otherwise indicated on the plans.

Install sheet metal forms in such a manner as to minimize leakage during concrete placement. Support forms to prevent displacement during precasting operations and to obtain the proper concrete thickness. Use casting beds and forms with provisions for holding the steel grid panels flat and square prior to placing concrete. Check the steel grid panels for conformity with the required dimensions as to cross slope.

Furnish completed precast panels with dimensional tolerances between adjacent panels of ± 0.25 inches horizontally and ± 0.125 inches vertically.

Texture the surface in accordance with the requirements of Section 500.3 .05.T.9.A and Special Provision 519 to accommodate the co-polymer overlay.

505.2.04 Field Placed Concrete

For the closure pours and shear keys, provide 24 hour accelerated strength concrete in accordance with Section 504 of the Standard Specifications, except as follows:

1. Furnish accelerated strength concrete designed to produce a compressive strength of 3,500 psi (24 MPa) within 24 hours and 4,000 psi (27 MPa) after 3 days, as well as a minimum bond strength of 200 psi after 24 hours.
2. Furnish concrete with a maximum coarse" aggregate size of 0.375".
3. Furnish field placed concrete with a color which closely matches the color of the precast deck panel concrete. Texture the surface in: accordance with the requirements of Section 500.3.05.T.9.A.
4. Do not allow traffic on the deck panels until the concrete has reached a minimum compressive strength of 3,500 psi.

505.3 Construction Requirements

505.3.01 Personnel

Provide a Project Manager meeting the requirements specified in 505.1.04.

505.3.03 Construction

Install the deck system using an installer trained and licensed by the manufacturer in installing the specified system. Install the deck system in accordance with the manufacturer's recommendation and the following:

1. Field verify all dimensions to ensure proper fit of the deck panels. Position leveling devices to provide adequate clearance for field adjustment of panels from above using a socket wrench and for adequate clearance for field placement of headed shear studs.
2. Prior to deck panel installation, blast clean the top surfaces of beam flanges and the surfaces of concrete and uncoated reinforcing steel to be in contact with new rapid-setting concrete in accordance with Section 535 of the Specifications.
3. Place panels on the structure with careful consideration given to the alignment of each adjacent panel. Measure from fixed points to avoid cumulative error. Do not use rebar as lifting points.
4. Adjust panels to the proper elevation through the use of the built-in leveling bolts.
5. Shear Connector Installation:
 - a. Option 1: After adjusting all panels to their proper elevation and placement of haunch and associated formwork, weld shear connectors to the top flange of the existing steel girders as detailed on the plans through the unfilled areas provided in the deck panels.
 - b. Option 2: With careful layout, weld studs down prior to placing deck panels. Use a separate welding generator to furnish power to each stud gun in order to assure acceptable welds.
6. After all studs and bolts are installed, clean the top surface of all flanges, including breaking the ceramic ferrules around the welded studs, before placing any concrete.
7. Use a rigid lifting frame whenever handling the precast panels.

Use a pencil vibrator in the haunch and shear key areas to assure good consolidation. Perform consolidation using hand-held vibrators when placing the mixture around steel reinforcement or structural members. Texture the surfaces of the cast-in-place concrete closures in accordance with the requirements of Section 500.3.05.T.9.A.

Once all of the panels are installed across the full length of the bridge, perform surface grinding of the Y4" overfill depth within the area of the precast panels and closure pours to ensure a smooth transition between the panels and the existing deck to remain and between adjacent panels. Satisfy the surface tolerances as found in Section 500.3.06.E of the Standard Specifications except as noted on the Plans. Do not begin surface grinding until the closure pours have reached minimum compressive strength. Provide a surface texture which meets the requirements of the copolymer overlay as specified in Special Provision 519.

505.3.04 Quality Acceptance

Certification from the manufacturer, showing that the deck installation conforms to their requirements, is required in accordance with Subsection 106.05 of the Specifications. Transfer to the Department the manufacturer's five-year warranty on each installation.

505.3.05 Contractor Warranty and Maintenance

Provide a warranty in writing, for a period of 60 months after successful completion and acceptance of the project, for all deck panel work against defective material and workmanship. Furnish the written warranty to the Department for approval prior to installation of the proposed deck system. The warranty is to state that it is subject to transfer to the Department

APPENDIX D

Verification of SAP2000 Live Load Calculation Procedure

1. TEST SETUP

Test Cross-Section

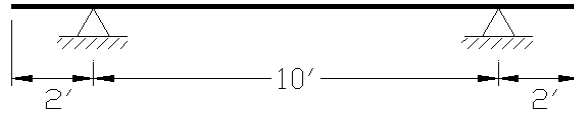

Live Load

- The live load is from the HL-93 truck with no lane loads and a 0% impact factor
 - Lane loads are to be neglected for deck design (AASHTO LRFD Bridge Design 2008 3.6.1.3.3)
 - The appropriate impact factors will be applied later
- The live load cannot be placed within one foot of the edge of the cross-section

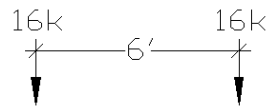

2. HAND CALCULATIONS

The moment envelope for a single point load is shown below in Figure 2.1. Calculations were done by hand through statics and this data was input into Microsoft Excel. It is apparent from this figure that the maximum moment will occur at mid-span and the minimum moment will occur at both of the supports (for a single point load). The influence lines for these sections are needed to determine the expected maximum and minimum moments for the live load case.

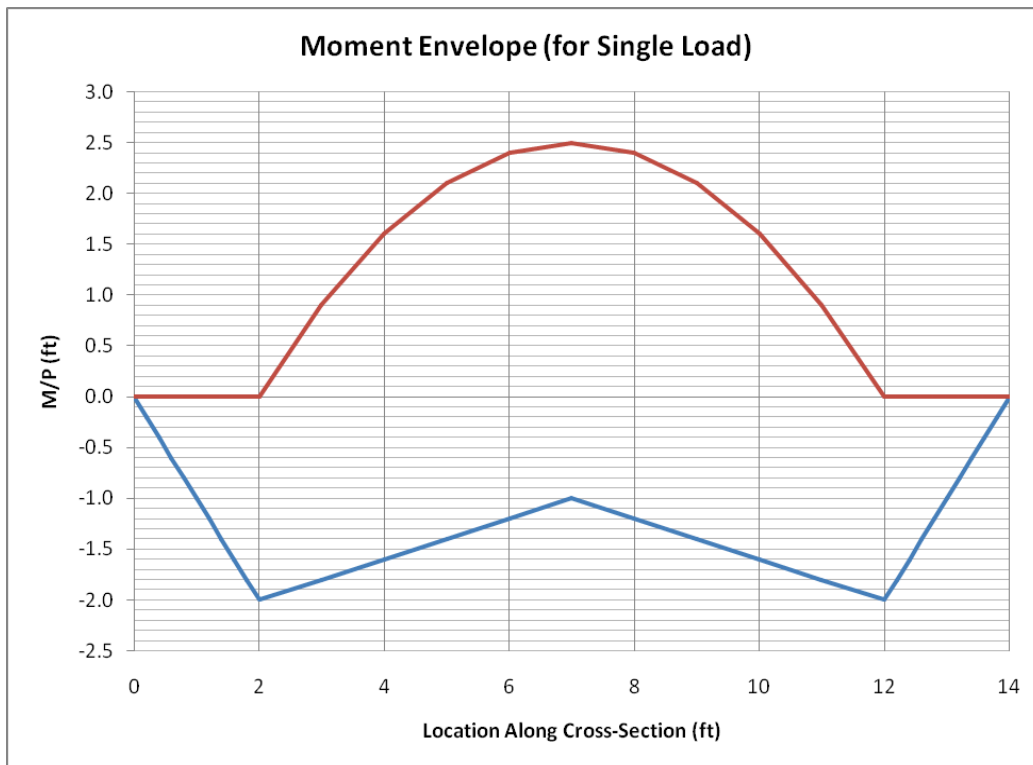

Figure 2.1. Moment Envelope for Single Load

Figures 2.2, 2.3, & 2.4 below show the moment influence lines for the mid-span and support sections (110/200, 205, and 210/300) and the minimum/maximum moment that corresponds to each. As seen from these figures, the moment is expected to be -16 (kip-ft) at both of the supports and 32 (kip-ft) at mid-span.

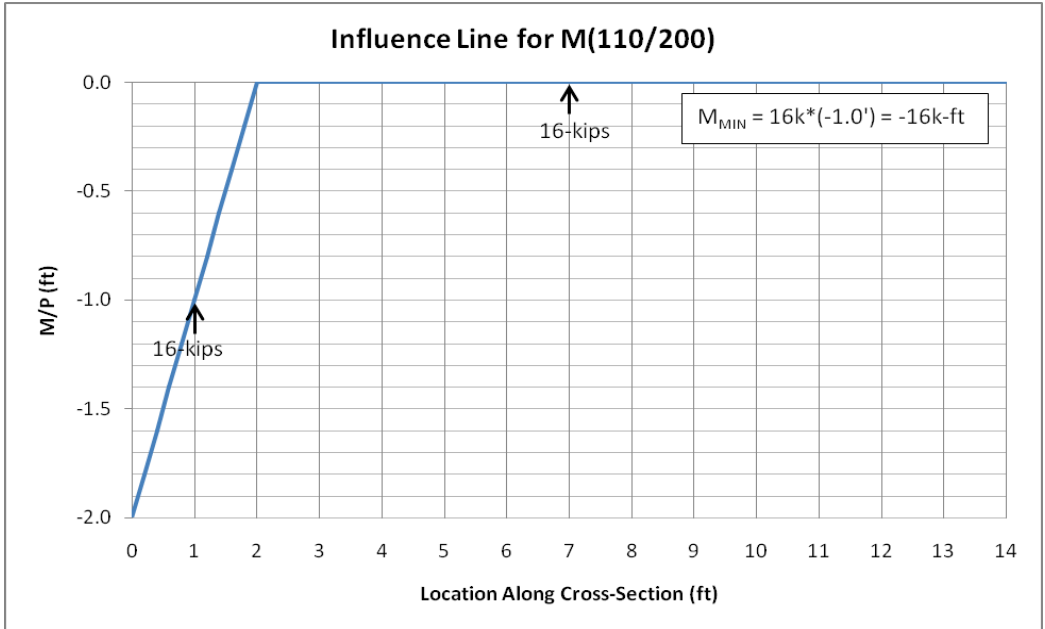

Figure 2.2. Moment Influence Line for Section 110/200

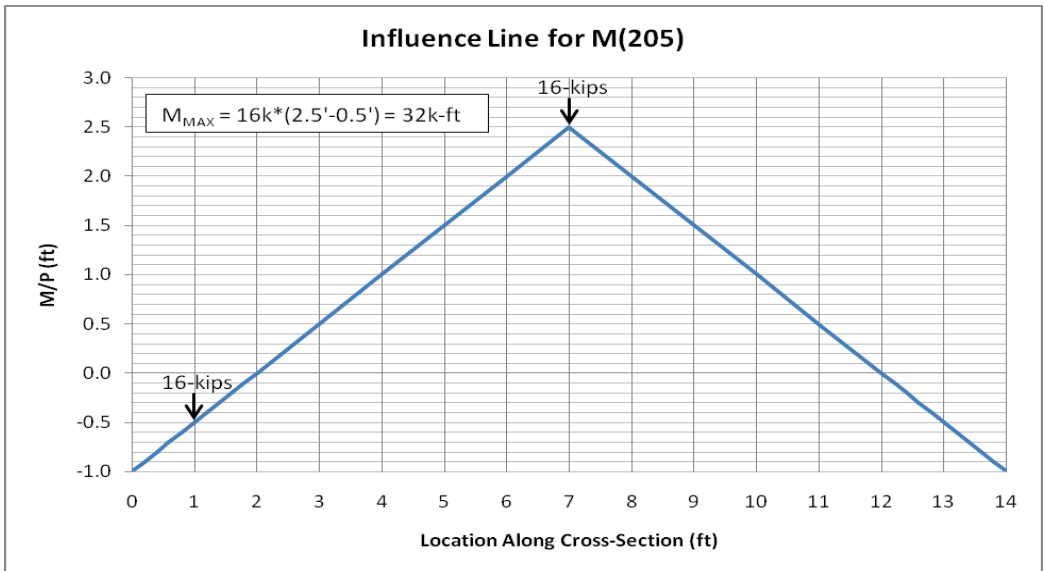

Figure 2.3. Moment Influence Line for Section 205

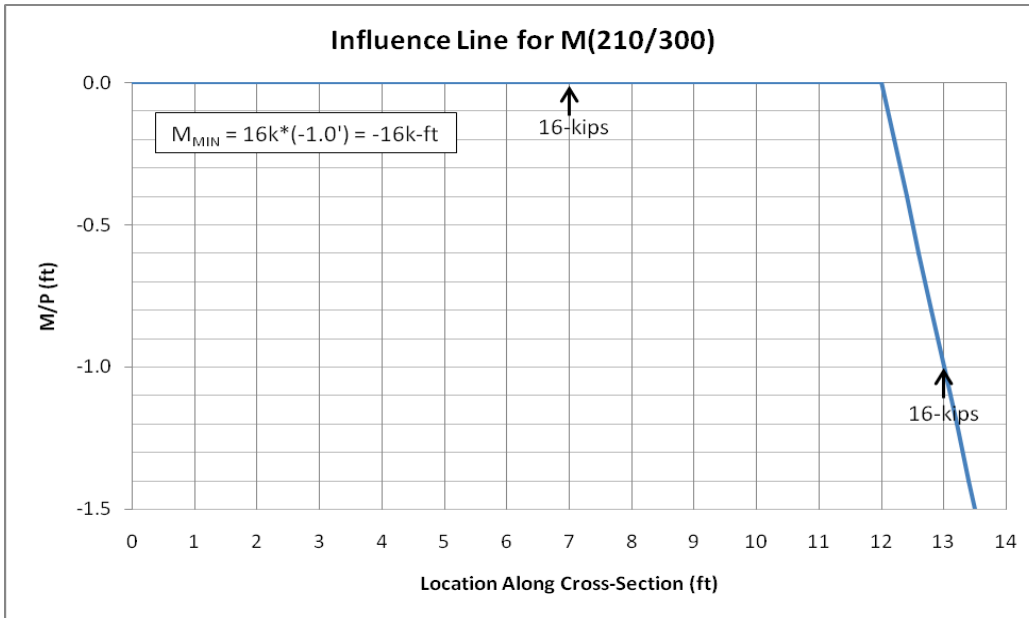

Figure 2.4. Moment Influence Line for Section 210/300

After following the procedure discussed in the next section (Section 3), it is apparent that the maximum moment for the live load case will occur at Section 204. The influence line for this section as well as the maximum moment for the live load case is shown below in Figure 2.5. The calculated maximum moment is 38.4 (kip-ft).

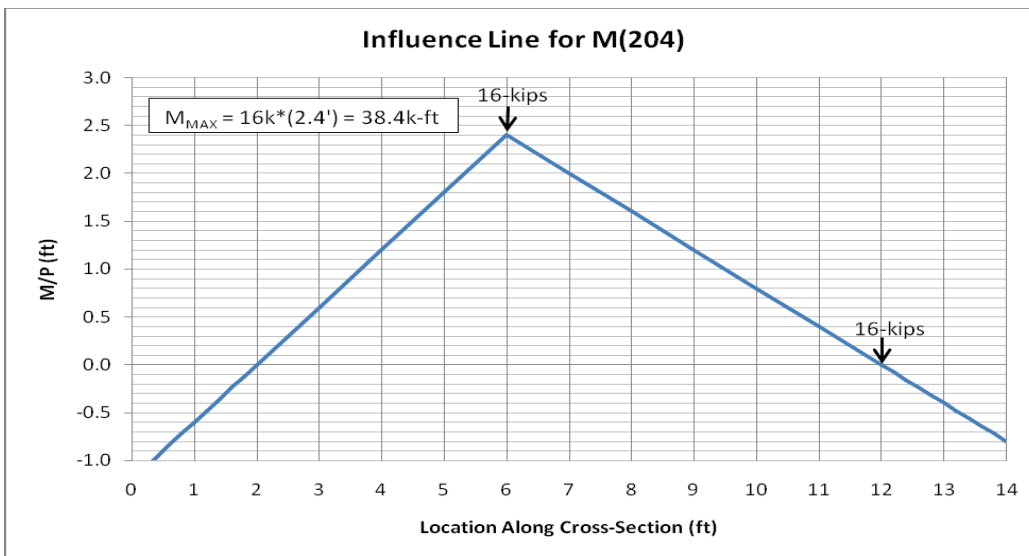

Figure 2.5. Moment Influence Line for Section 204

3. SAP2000 PROCEDURE (SAP2000 V14)

This procedure was done using SAP2000 V14. Deviation from this procedure may be necessary for different versions of the software.

The test-cross section was modeled in SAP2000 with frames and joints. Section properties were ignored since the live load is the only load being considered and only shear and moment values are desired.

Initial Loading Procedure

An initial attempt to use the moving load capabilities of the software was taken. To model the live loads placement across the cross-section, a lane had to be defined. The lane was defined by the frames where the live load is allowed to be placed. This procedure is as follows.

- First we need to display the frame numbers
 - View > Set Display Options (Ctrl-E)
 - Check “Labels” under “Frames/Cables/Tendons”
- Define > Bridge Loads > Lanes
- Click “Add New Lane Defined From Frames”
- Input values shown below in Figure 3.1 and click “OK”
- Click “OK”

Lane Data

Lane Name: LANE1

Frame	Centerline Offset	Lane Width
6	0	0
5	0	0
2	0	0
6	0	0

Buttons: Add, Insert, Modify, Delete, Reverse Order, Reverse Sign, Move Lane...

Lane Edge Type:
 Left Edge: Interior
 Right Edge: Interior

Maximum Lane Load Discretization Lengths:
 Along Lane: 12
 Across Lane: 1

Additional Lane Load Discretization Parameters Along Lane:
 Discretization Length Not Greater Than 1/ [] of Span Length
 Discretization Length Not Greater Than 1/ 12 of Lane Length

Objects Loaded By Lane:
 Program Determined
 Group []

Display Color: ■

Buttons: OK, Cancel

Figure 3.1. Lane Data

The next step is to define the vehicle. This was done as follows.

- Define > Bridge Loads > Vehicles
- Select “Add General Vehicle” from the pull down menu under “Choose Vehicle Type to Add”
- Click “Add Vehicle”
- Input values shown below in Figure 3.2 and click “OK”
- Click “OK”

General Vehicle Data

Vehicle name: GEN1 Units: Kip, ft, F

Floating Axle Loads

	Value	Width Type	Axle Width
For Lane Moments	0.	One Point	
For Other Responses	0.	One Point	

Double the Lane Moment Load when Calculating Negative Span Moments

Usage

Lane Negative Moments at Supports
 Interior Vertical Support Forces
 All other Responses

Min Dist Allowed From Axle Load

Lane Exterior Edge: 0.
Lane Interior Edge: 0.

Length Effects

Axle: None
Uniform: None

Loads

Load Length Type	Minimum Distance	Maximum Distance	Uniform Load	Uniform Width Type	Uniform Width	Axle Load	Axle Width Type	Axle Width
Leading Load	Infinite		0.	Zero Width		16.	One Point	
Leading Load	Infinite		0.	Zero Width		16.	One Point	
Fixed Length	6.		0.	Zero Width		16.	One Point	
Trailing Load	Infinite		0.	Zero Width				

Vehicle Applies To Straddle (Adjacent) Lanes Only Straddle Reduction Factor:
 Vehicle Remains Fully In Lane (In Lane Longitudinal Direction)

Figure 3.2. General Vehicle Data

The next step is to define the vehicle class as follows.

- Define > Bridge Loads > Vehicle Classes
- Click “Add New Class”
- Click “Add” to add “GEN1” with a scale factor of 1.
- Click “OK”
- Click “OK”

The final step is to define the load case. This is done as follows.

- Define > Load Cases
- Click “Add New Load Case”
- Input the values shown below in Figure 3.3 and press “OK”
- Press “OK”

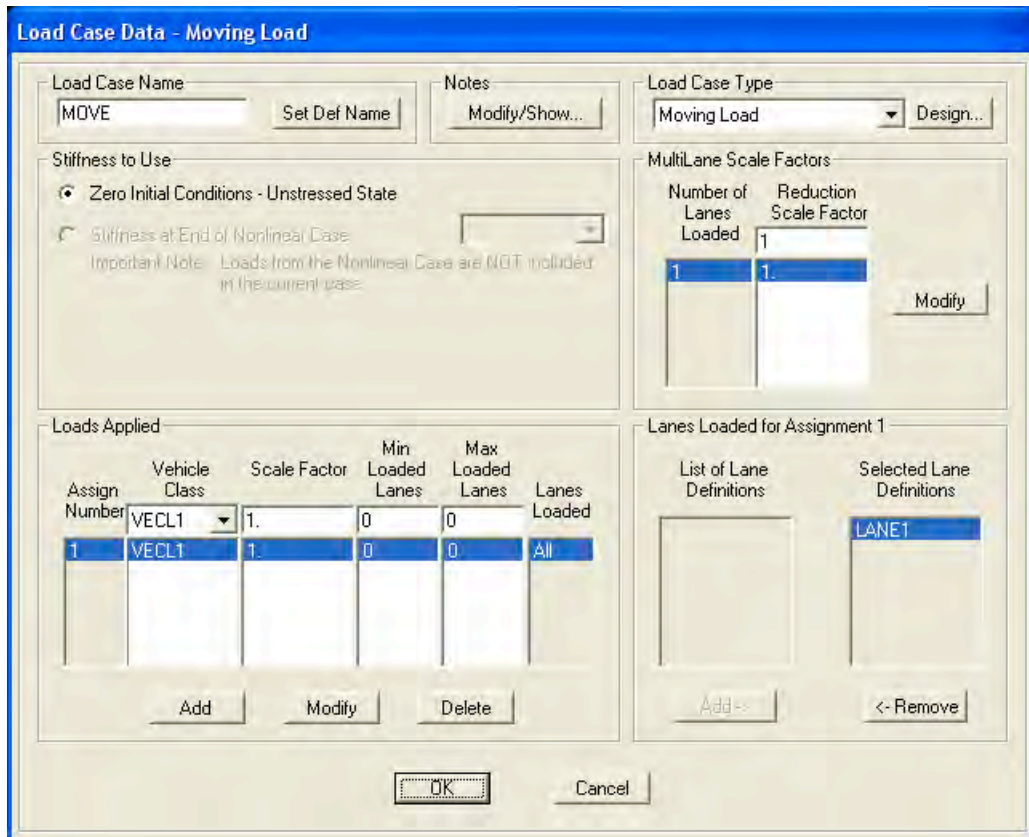

Figure 3.3. Load Case Data

This concludes the live load case definition. From here the “MOVE” load case was analyzed. The results are shown below in Figure 3.4.

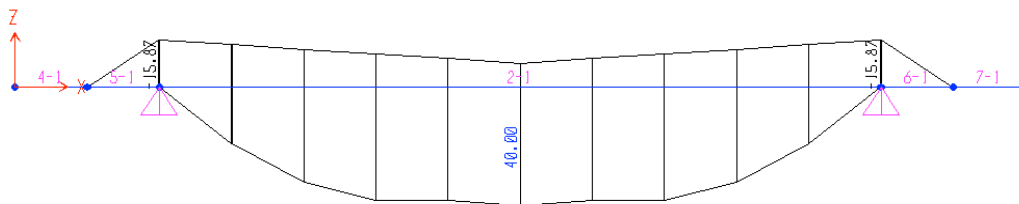

Figure 3.4. SAP2000 Moment Envelope for Live Load

The value at mid-span is much larger than expected. According to the hand calculations, this should be 32 (kip-ft). Therefore, a conclusion was made that the “Vehicle Remains Fully In Lane (In Lane Longitudinal Direction)” option in the “General Vehicle Data” window doesn’t work as expected. This option is supposed to force all axle loads to remain in the lanes longitudinal direction. This is necessary for our modeling procedure since both wheel loads will always be on the cross-section. A moment of 40 (kip-ft) is what would result at mid-span if only one wheel load is present on the lane. Since this procedure provides incorrect data, another loading approach must be taken.

Brute Force Loading Procedure

Since the initial loading procedure was unsuccessful, a brute force approach was taken. To achieve correct results, the live load must be placed manually and moved manually across the cross-section. A load envelope can be created once the response from each of these load cases is attained. The procedure taken in SAP2000 is described below.

First, load patterns must be defined for each live load location. These load patterns will represent each live load location. This is done as follows.

- Define > Load Patterns
- Add load patterns as shown in Figure 3.5 below.
- Click “OK”

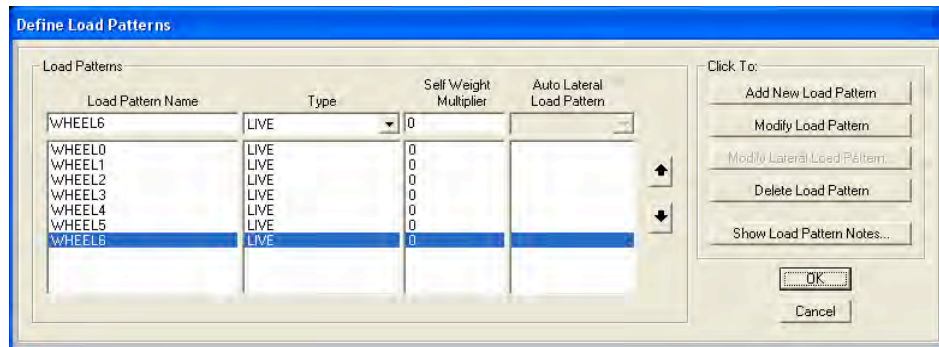

Figure 3.5. Define Load Patterns

The next step is to assign loads to the load patterns by loading the frames with the wheel loads at the appropriate locations. This procedure is outlined below for the first live load location. For this live load position, the first wheel load will be placed at $x=1$ (ft) and the second wheel load will be placed at $x=7$ (ft). These loads will be assigned to the “WHEEL0” load pattern.

- Select the frame to be loaded (Frame 5).
- Assign > Frame Loads > Point
- Input the values shown in Figure 3.6 and click “OK”

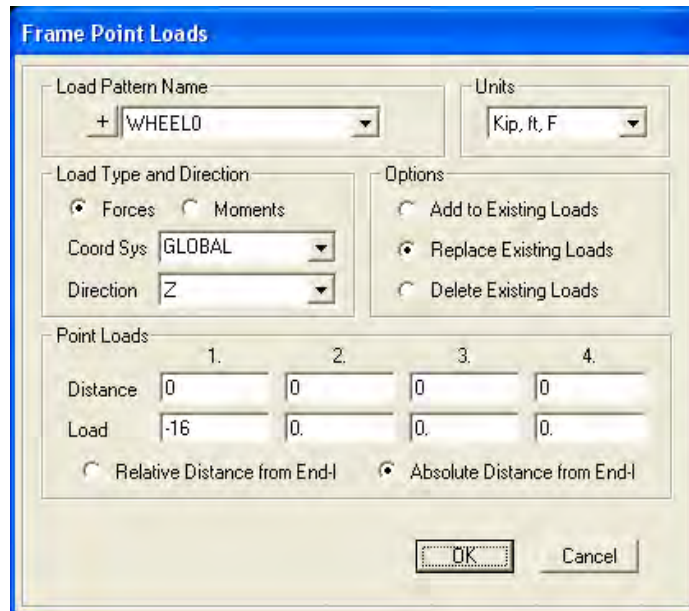

Figure 3.6. Frame Point Loads for WHEEL0, Frame 5

- Select the next frame to be loaded (Frame 2).
- Assign > Frame Loads > Point
- Input the values shown in Figure 3.7 and click “OK”

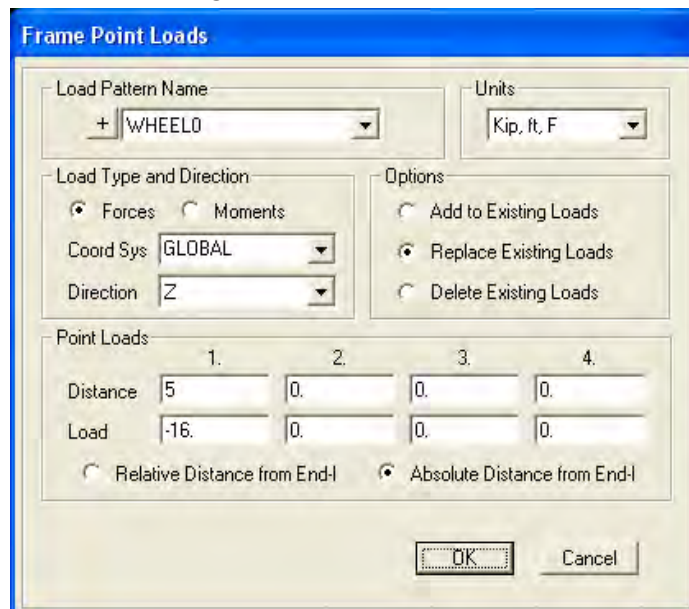

Figure 3.7. Frame Point Loads for WHEEL0, Frame 2

A similar procedure is done for the next live load location (WHEEL1). This is outlined as follows.

- Select the frame to be loaded (Frame 2).
- Assign > Frame Loads > Point
- Input the values shown in Figure 3.8 and click “OK”

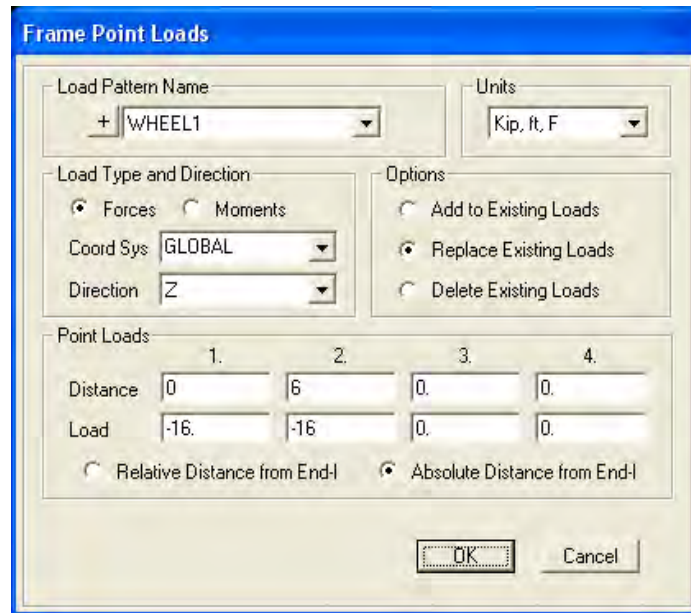

Figure 3.8. Frame Point Loads for WHEEL1

This process is repeated for all of the load patterns (WHEEL2 through WHEEL6).

The next step is to define a load combination to capture the moment envelope for the live load. This is outlined as follows.

- Define > Load Combinations
- Click “Add New Load Combo”
- Input the values shown below in Figure 3.9 and click “OK”
- Click “OK”

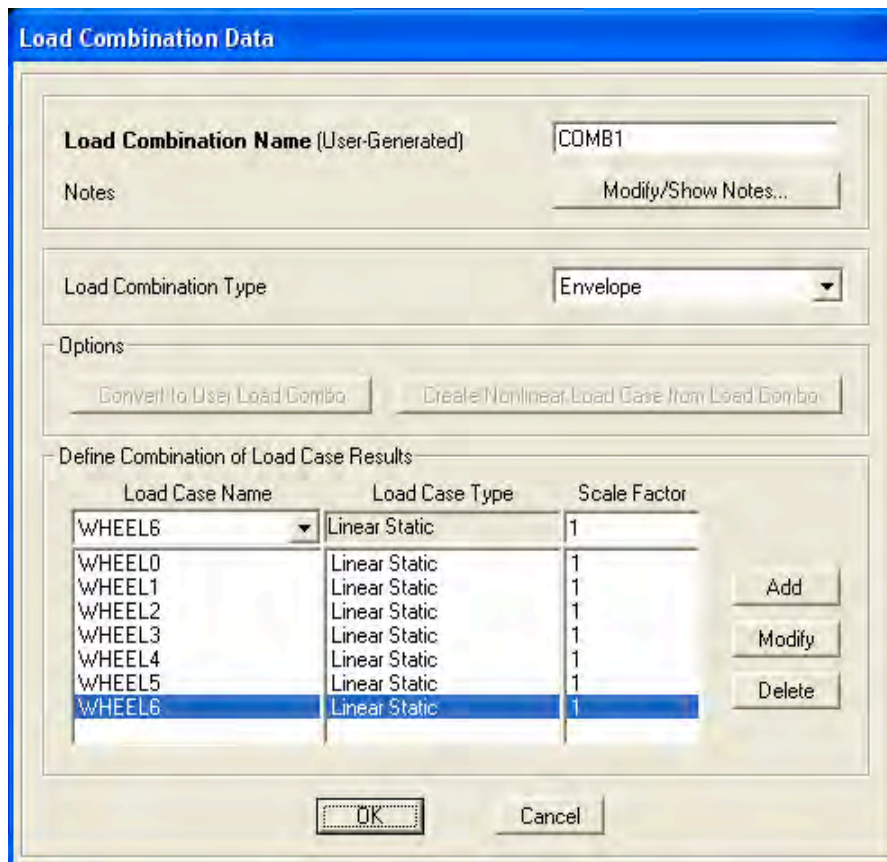

Figure 3.9. Load Combination Data

This concludes the live load procedure. From here all of the “WHEEL” load cases were analyzed. The following procedure is done to display the moment envelope for the live load. This moment envelope is captured by the “COMB1” load combination.

- Display > Show Forces/Stresses > Frames/Cables
- Input the values shown in Figure 3.10 and click “OK”

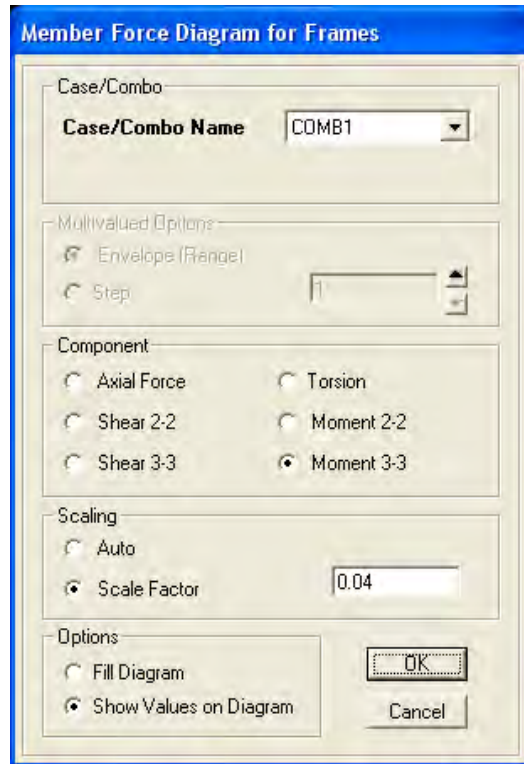

Figure 3.10. Member Force Diagram for Frames

The resulting moment envelope for the live load is shown below in Figure 3.11. These values are consistent with the hand calculations.

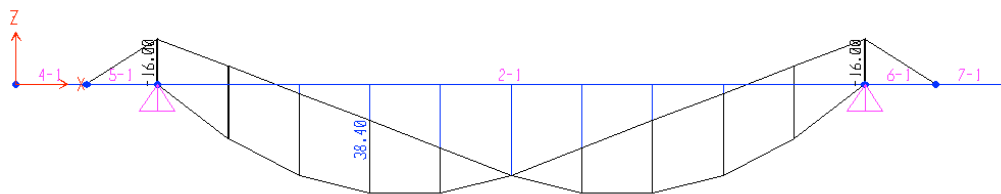

Figure 3.11. Live Load Moment Envelope

CONCLUSIONS

The expected maximum and minimum moments determined by hand are the same as those derived from SAP2000. This confirms that the SAP2000 procedure is correct. The brute force loading procedure is much more time consuming and far more difficult to do. This must be done since the automated moving load capabilities of the software doesn't work as expected.