

**Evaluations of Integrated Pest Management control techniques of the Asian cockroach  
(*Blattella asahinai* Mizukubo) in the Urban Environment**

by

Edward Todd Snoddy

A dissertation submitted to the Graduate Faculty of  
Auburn University  
in partial fulfillment of the  
requirements for the Degree of  
Doctor of Philosophy in Entomology

Auburn, Alabama  
May 6, 2012

Keywords: Invasive species, peridomestic pest, mulch preference

Copyright 2012 by Edward Todd Snoddy

Approved by

Arthur G. Appel, Chair, Professor of Entomology  
Xing Ping Hu, Professor of Entomology  
Jack W. Feminella, Professor of Biological Sciences  
Jeffrey L. Sibley, Barbara and Charles Bohman Professor of Horticulture

## Abstract

The objective of this research was to evaluate components of an Integrated Pest Management (IPM) program for the Asian cockroach, *Blattella asahinai* Mizukubo. IPM programs are more effective in control of cockroaches than insecticides alone. IPM programs are usually the most environmentally friendly because they drastically reduce the amount of pesticide residue.

The toxicity of seven consumer gel and paste insecticide baits was evaluated against Asian cockroaches in continuous exposure tests with and without competitive food. Bait toxicity and consumption varied with the gel and paste bait and with and without a competitive food source. Advion® was the most toxic insecticidal bait, however, and the  $LT_{50}$  value decreased in the presence of competitive food. The toxicity of nine consumer granular insecticide baits was evaluated against Asian cockroaches in continuous exposure tests with and without competitive food. Toxicity and consumption varied among the granular baits and with the presence of competitive food. Most baits had greater  $LT_{50}$  values when the cockroaches were presented competitive food. Performance of  $\beta$ -cyfluthrin EC and fipronil granules and an organic essential oil EC mixture was evaluated against Asian cockroaches in field and laboratory experiments. Results of the field applications and laboratory experiments indicate the best choice for control of the Asian cockroach would be  $\beta$ -cyfluthrin EC and fipronil granules.

Mulch preferences of the Asian cockroach were determined in a series of laboratory experiments. Five mulches were used: cypress, oak leaf litter, pine straw, rubber, and topsoil. In

large arena tests, adult males preferred oak leaf litter and pine straw, while adult females preferred oak leaf litter and rubber mulches. All nymphal stages preferred the rubber ( $48.33 \pm 13.08\%$ ) over all other mulches. Light preferences of the Asian cockroach were evaluated under urban field conditions. Adults preferred compact fluorescent and incandescent light over the other lights. No adults were observed at red and LED lights, and only one adult was observed at the yellow light. These findings were consistent with other domestic and peridomestic cockroach behavior to lights.

## Acknowledgments

I thank Dr. Arthur G. Appel for his support, ideas, and assistance in my research work, and for believing in me as a graduate student. I thank my committee members, Dr. Xing Ping Hu, Dr. Jeffrey L. Sibley and Dr. Jack W. Feminella for their guidance, suggestions and support. I thank Dr. Troy L. Best for assisting as an outside reader and his inputs. I thank Marla J. Eva in assistance in the laboratory. I thank Dr. Wayne E. Clark and Dr. Gary L. Mullen for their excellent teaching abilities, which fostered my interest in entomology as an undergraduate and later were a determining factor to return as a graduate student. I thank Dr. Steve “Bug” Brown, University of Georgia, for his assistance, support, and guidance through my career. Above all, I greatly thank my wife Tracy, and children; Johnhenry, Samantha Snoddy Smith, Michael Smith, and Sullivan Michelle Smith, my mother Lucy Mae Snoddy, and John T. and Bettie Smith; whose love and encouragement, and unwavering support throughout my research allowed me to achieve this accomplishment. I dedicate this dissertation to my late father Dr. Edward L. Snoddy, who opened my eyes at a young age to the wonderful world of insects and their importance, which ultimately inspired me to become an entomologist.

## Table of Contents

Abstract .....	ii
Acknowledgments.....	iv
List of Tables .....	vii
List of Figures .....	ix
Chapter 1: Introduction .....	1
Introduction .....	1
References .....	12
Chapter 2: Performance of Consumer Insecticide Gel and Paste Formulations in Control of the Asian Cockroach <i>Blattella asahinai</i> Mizukubo (Dictyoptera: Blattellidae) .....	21
Introduction .....	21
Materials and Methods .....	24
Results .....	25
References .....	29
Chapter 3: Performance of Consumer Granular Bait Formulations in Control of the Asian Cockroach <i>Blattella asahinai</i> Mizukubo (Dictyoptera: Blattellidae) .....	36
Introduction .....	36
Materials and Methods .....	38
Results .....	40
References .....	44
Chapter 4: Field and Laboratory Efficacy of Three Insecticides Against the Asian Cockroach ( <i>Blattella asahinai</i> , Mizukubo) in an Urban Environment .....	52

Introduction .....	52
Materials and Methods .....	55
Results .....	60
References .....	65
Chapter 5: Mulch Preferences of the Asian Cockroach, <i>Blattella asahinai</i> , Mizukubo .....	72
Introduction .....	72
Materials and Methods .....	74
Results .....	78
References .....	85
Chapter 6: Light Preferences of the Asian Cockroach, <i>Blattella asahinai</i> Mizukubo.....	94
Introduction .....	94
Materials and Methods .....	96
Results .....	98
References .....	103

## List of Tables

### Chapter 2:

Table 1: Gel insecticides used in evaluation of the Asian cockroach toxicity experiments..... 32

Table 2: Toxicity of gel insecticides with and without competitive food to adult male Asian cockroaches in continuous exposure experiments. .... 33

Table 3: Mean ( $\pm$ SE) consumption of gel and paste baits with and without competitive food with adult male Asian cockroaches in continuous exposure experiments. .... 35

### Chapter 3:

Table 1: Granular bait insecticides used in the evaluation of the Asian cockroach toxicity experiments. .... 47

Table 2: Toxicity of granular insecticides with and without competitive food to adult male Asian cockroaches in continuous exposure experiments. .... 48

Table 3: Mean ( $\pm$ SE) consumption of granular baits with and without food to adult male Asian cockroaches in continuous exposure experiments. .... 50

### Chapter 4:

Table 1: Toxicity of insecticides to adult male Asian cockroaches exposed in either continuous or Ebeling choice box experiments ..... 68

Table 2: Repellency of male adult Asian cockroaches to insecticides in Ebeling choice boxes 69

Table 3: Mean ( $\pm$ SE) number Asian cockroaches sampled at Dothan, AL field sites before and after insecticide treatments. .... 70

### Chapter 5:

Table 1: Mulch preferences of different stages of the Asian cockroach in large arena experiments. .... 88

Table 2: Repellency of mulches to adult male Asian cockroaches in Ebeling choice boxes. .... 89

Table 3: Linear regressions of the repellency of mulches and untreated control to adult male Asian cockroaches tested in Ebeling choice boxes.....90

Table 4: Toxicity of mulches to adult male Asian cockroaches confined in Ebeling choice boxes. ....91

Chapter 6:

Table 1: Type of lights and mean number of Asian cockroaches ..... 106

Table 2: Weather data for light preference experiments at Landmark Park, Houston County, Dothan, AL.. ..... 107



## List of Figures

### Chapter 1:

Figure 1: Cladogram showing cockroach and termite phylogeny .....	16
Figure 2a: Tergal gland of adult male Asian cockroach .....	17
Figure 2b: Tergal gland of adult male German cockroach .....	18
Figure 3a: Adult male Asian cockroach (dorsal) .....	19
Figure 3b: Adult gravid female Asian cockroach (lateral) .....	20

### Chapter 4:

Figure 1: Mean percentage reduction of Asian cockroach numbers following treatments. Note negative percentage reduction indicates an increase in cockroach numbers. ....	71
--	----

### Chapter 5:

Figure 1: Repellency of mulches and untreated control of adult male Asian cockroaches tested in Ebeling choice boxes .....	92
--	----

### Chapter 6:

Figure 1: Average number of adult Asian cockroaches by light and time period .....	108
Figure 2: Average number of Asian cockroach adults by light treatment .....	109

## Chapter 1

### Introduction

**Insects.** Insects are thought to first have originated about 400 million years ago during the Late Silurian period (Grimaldi and Engel 2005), which would make them some of the first terrestrial animals that appeared on the planet. There are about 925,000 known species of insects, but estimates run from 2.5 to 10 million species with an average estimate of ~ 5 million total species (Grimaldi and Engel 2005). There are four orders; Coleoptera, Diptera, Hymenoptera, and Lepidoptera, which account for 80% of insect species (Grimaldi and Engel 2005). Entomologists have generally avoided studying the early insects due to the difficulty in studying fossils. The space, time, and structures of fossils are difficult to master and understand. There are huge gaps in the geology history of many fossils groups, and the lack of detailed morphology of most insect fossils makes it difficult to positively identify characters and make precise assumptions concerning the relationship of fossil insects. When insects achieved flight, some 90-170 million years before vertebrate flight (Brauckmann et al. 1996, Grimaldi and Engel 2005), they began to achieve their greatest diversity. Flight allows dispersal, another means to avoid predation, and to become more efficient predators themselves. Wings allow insects to develop more elaborate coloration, which in turn, allows them to advertise their toxins and venoms, and blend into the environment through mimicry and camouflage. Winged insects developed behaviors such as flying in loops, which could

have been an adaptation to avoid predation by bats, and other insects. Winged insects also integrated the use of wings into mating by using them in elaborate courtship behaviors, dispersal of pheromones, and simple flight to find a mate. Only insects have evolved to have complex eusocial societies such as those seen in termites, ants, and bees. Insects have been instrumental in the evolution of plants. There are approximately 250,000 species of plants and 85% of them require pollination by insects (Grimaldi and Engel 2005). Insects also evolved to feed on these plants and cause hundreds of million dollars in damage to many food and ornamental crops. Insects are not limited to interactions with plants; they have evolved to inhabit just about every niche on the planet with the exception of the benthic zone, and the marine environment; although there are a few insects that utilize the seashores and one genus of water striders, *Halobates* spp., which inhabits the open waters of the oceans (Merritt and Cummins 1996, Grimaldi and Engel 2005).

Insects have evolved over time to adapt and utilize their environment. Insects have evolved to feed on humans, and have played important roles in history. There are several diseases transmitted by insects that had significant roles in human history; epidemic typhus, Chaga's disease, sleeping sickness, malaria, yellow fevers, and plague. Insects and the diseases they vector have even played a role in human mutation and evolution (e.g., Sickle cell anemia, Mullen and Durden 2002). Insects play an important role in the ecology and life cycle of many diseases since they are the major vectors of many diseases (Mullen and Durden 2002).

**Cockroaches.** Cockroach origins date back 350-400 million years to the Devonian period of the Paleozoic era. There has been little change in their morphology

since then. Paleontologists have grouped ancient cockroaches into an order named Dictyoptera. This order contained the ancient orders of Blattaria, Isoptera, Mantodea, and Paleozoic Roachoids (Hennig 1981). The Roachoids had large pronota covering the head, large flattened coxae for running, a dorso-ventrally flattened body, tegminous forewings, and a large external ovipositor. The only morphological difference between the modern cockroaches and the ancient Roachoids is the presence of the long external ovipositor on the Roachoids. Therefore, cockroaches have changed very little over the last 300 million years. The Paleozoic Roachoids first appeared in the early part of the late Carboniferous period (~ 320 million years ago) and lasted until the late Permian period (~ 255 million years ago) (Grimaldi and Engel 2005). Schneider (1983, 1984) reviewed and revised the classification of the fossilized Roachoids, and divided them into three families: Archimylarididae, Necymylacrididae, and Mylacrididae. As these families became extinct they gave rise to new families during the Mesozoic period such as Raphidiomimidae. This family was a predatory Roachoid resembling a mantid that had a long prognathous head, long palps, narrow pronotum that exposed the head, long slender wings, fore femur and fore tibia had two rows of spines and the fore legs appeared to be held forward (Grimaldi and Engel 2005).

Cockroaches are thought to be closely related to termites (Fig. 1). Some cockroach species have flagellated protozoa in their digestive systems similar to those of termites. Some species of the cockroach genus *Panesthia*, burrow into tunnels in the soil and lose their wings like termites, which would inhibit their movement in the burrows (Grimaldi and Engel 2005). One genus of cockroach that is considered the “missing link” between the termites and cockroaches is *Cryptocercus*. *Cryptocercus* is so named because

its cerci are recessed between the last abdominal segments (supraanal and subgenital plates). The young of *Cryptocercus* feed on their mother's excretions that contain protists from her hindgut that digest cellulose (proctodeal trophallaxis). This behavior is similar to termites and how they pass along the protists to young. *Cryptocercus punctulatus* (Scudder) is the most common and well studied of this genus, but other species are found in several locations worldwide mostly in undisturbed temperate mountain forests. There are several species of *Cryptocercus* that have recently been discovered in the southeastern United States: *C. garciai* from northwest Georgia, *C. darwini* from Tennessee, Alabama, and North Carolina; and *C. wrighti* from North Carolina and Tennessee (Clark et al. 2001). *Cryptocercus* spp. shares the same distinctive protists as two other families of termites (Termitidae and Rhinotermitidae) (Grimaldi and Engel 2005).

Cockroaches are also related to Mantodea, in part, because both orders deposit their eggs within an ootheca. In the cockroaches, most oothecae are hard bean-like egg cases that have two rows of eggs and are deposited on the habitat substrate using a glue-like secretion. In the mantids, the ootheca is extruded onto the habitat substrate in a froth-like excretion that hardens to a foam consistency; mantid oothecae also contain two rows of eggs. Another morphological feature that ties all three orders together is the proventriculus. The proventriculus is a gizzard-like organ that aids in the digestion of food. The proventriculus is located between the foregut and mesentron in the digestive tract. The proventriculus has many folds in it called plicae. The plicae have sclerite tooth-like structures (acanthae) that help break up and digest the food. The morphology of the plicae and acanthae are very similar in the three orders (Klass 1998).

**Systematics and Taxonomy of Cockroaches.** The study of the diversity of organisms and the relationship between them is termed systematics and the related field of taxonomy classifies these organisms. Cockroaches are characterized by their dorsoventrally flattened body where the head is largely concealed beneath the pronotum. Cockroaches have prominent cerci, chewing mouthparts, and prominent antennae. Cockroaches do not have enlarged hind femurs used for jumping as some of their closest relatives (Orthoptera) do, but are still very fast runners. Cockroaches, once considered members of the order Orthoptera (Helfer 1987), have been in recent years placed in their own order of Blattodea (Triplehorn and Johnson 2005), although some taxonomists prefer Dictyoptera (Roth 1986). Cockroaches differ from members of the order Orthoptera because they lack a prominent ovipositor. The order Dictyoptera contains five families; Cryptocercidae, Blattidae (e.g., oriental cockroach, American cockroach), Polyphagidae (e.g., sand cockroaches), Blattellidae (e.g., brownbanded cockroach, German cockroach), and Blaberidae (e.g., giant cockroach), with 4000-5000 species worldwide (Roth 1986). About 70 species occur in the United States, of which 24 species have been introduced (Clark et al. 2001). There are roughly 11 species that are commonly found in the southeastern United States; oriental cockroach, *Blatta orientalis* L., American cockroach, *Periplaneta americana* L., Australian cockroach, *Periplaneta australasiae* (Fab.), Brown cockroach, *Periplaneta brunnea* Burmeister, smokybrown cockroach, *Periplaneta fuliginosa* (Serville), Florida woods cockroach, *Eurycotis floridana* (Walker), brownbanded cockroach, *Supella longipalpa* (F.), German cockroach, *Blattella germanica* (L.), Asian cockroach, *Blattella asahinai* Mizukubo, Surinam cockroach,

*Pycnoscelus surinamensis* (L.), and Cuban cockroach, *Panchlora nivea* (L.) (Clark et al. 2001).

**Biology and Ecology of Cockroaches.** Cockroaches are generally tropical to subtropical insects that live outdoors, except for the relatively few that have adapted to living domestically with humans. Cockroaches are omnivores and because of their tendency to aggregate, cannibalism can occur. Cockroaches are typically nocturnal insects, although there are many brightly colored diurnal species. Many female cockroaches produce a volatile blend of sex pheromones when they are ready to mate (Roth and Barth 1954, Roth and Willis 1967, Rust et al. 1995). These pheromones can attract males from some distance and cause the male to initiate courtship behavior. Many male cockroaches have a tergal gland located on their 7-8 abdominal segments, which is used to attract a female during mating (Roth and Barth 1954, Roth and Willis 1967, Rust et al. 1995). These tergal glands can be of morphological importance (Fig. 2a and b) when identifying similar species (Snoddy 2007). The male will unfold his wings and use them to fan the tergal gland excretion to attract the female. Once the female has approached the male and started feeding on the secretion of the tergal gland, the male will mate with the female (Roth and Barth 1954, Roth and Willis 1967, Rust et al. 1995, Bell et al. 2007). The female cockroach has an organ called a spermatheca, which serves as a storage vessel for the male's sperm. Once mated, the female has a life-long supply of sperm which will be used to produce multiple oothecae during her life span (Bell et al. 2007). Once the female has produced her eggs and fertilized them with the sperm from her spermatheca they are enclosed in an egg case or ootheca (Bell et al. 2007). The appearance of the ootheca varies among the cockroach species and has taxonomic

importance (McKittrick 1964). Depending on the species of the cockroach, oothecae are deposited in the habit of the cockroach or carried around by the female until the eggs hatch. Females can carry the oothecae exposed (e.g., *B. germanica* and *B. asahinai*) or they will carry the oothecae inside them until they hatch which is termed ovoviviparity (e.g., *Gromphadorhina portentosa* Schaum). Once the eggs hatch, the small cockroaches (nymphs) are independent and generally receive no assistance from the adults (Roth and Barth 1954, McKittrick 1964, Roth and Willis 1967, Rust et al. 1995, Bell et al. 2007). Cockroaches are paurometabolous insects and the juveniles (nymphs) closely resemble the adults morphologically. Developmental times depend on temperature, relative humidity, and food supply. Typically, oothecae can contain 6-40 eggs depending on species (Bell et al. 2007). Like the German cockroach, the female Asian cockroach carries an ootheca until the time the eggs hatch (Fig. 3b) (Atkinson et al. 1999, Koehler and Patterson 1987). The eggs are sensitive to water loss and therefore the oothecae remain attached to the female to supply it ample moisture. There are normally 6-7 instars in cockroaches and the nymphs tend to aggregate. Developmental time (from egg to adult) varies by species and ranges from 52-103 d so there can be several generations per year. Nymphs generally inhabit the same environment as adults and may also interact with adults (Rust et al. 1995). Cockroaches that are domiciliary can go through many generations per year (Rust et al. 1995), whereas outdoor species cockroaches may be limited to 2-3 per year depending on environmental conditions (Appel and Smith 2002). Cockroaches will inhabit locations, which are occupied by other cockroach species and compete with them for resources; but, they may not necessarily interact with them (Appel and Smith 2002).



**Peridomestic Cockroaches.** Cockroaches can be an economic pest associated with the food industry and for homeowners. Cockroaches can mechanically vector or transmit certain pathogens such as *Salmonella spp.* by physically contaminating food or food preparation surfaces (Kopanic et al. 1994, Tatteng et al. 2005). A cockroach infestation usually indicates poor sanitation practices. Infestations in homes do not necessarily imply poor housekeeping practices because cockroaches can build up populations outdoors, particularly large species, such as the smokybrown cockroach, and move inside as they forage for food (Appel and Smith 1996, 2002). Foodstuffs can be contaminated inside a house with cockroach feces, body parts, and pathogens. Humans can have allergies from cockroaches when populations are allowed to increase inside the home (Ebeling 1978). Most of these allergies are asthmatic in nature and, in some cases, can be life threatening (Roth and Willis 1957, 1960, Ebeling 1978).

**Asian Cockroach.** One particular species, *B. asahinai*, commonly known as the Asian cockroach (Fig. 3a and b) was first described in 1981 from Okinawa, Japan (Mizukubo 1981), was introduced into Florida in 1986 (Brenner et al. 1986). The first account of the Asian cockroach was limited to three adjacent counties in Florida from Tampa to Lakeland (Brenner et al. 1988). By 1993, the Asian cockroach had spread to 30 counties in Florida. The Asian cockroach also was found in citrus groves in Florida as well, and several studies evaluated whether it was a pest on citrus (Brenner et al. 1988). By 1999, it was distributed in 48 counties in Florida from Dade (southern part of Florida peninsula) to Nassau (in northern Florida) ( Koehler 1999, Richman 2005). Populations of the Asian cockroach have also been reported in the Florida panhandle in Santa Rosa County (Donahoe 2005). As of 2007, every county in Florida was thought to have an

established population of Asian cockroaches (P.G. Koehler, personal communication, 2007).

In early 2003, the Asian cockroach was identified for the first time outside of Florida in Dothan, AL. (Hu et al. 2005). These cockroaches were found in homes, churches, and public parks (Snoddy et al. 2008, Appel et al. 2009). A review of the literature revealed the spread of the Asian cockroach outside the state of Florida in Alabama and Georgia (Snoddy and Appel 2008). Snoddy and Appel (2008) found that it is established in seven counties in Georgia and eight counties in Alabama. The area that it has colonized in Alabama is double that of Georgia, and they developed distribution maps to document the range of the Asian cockroach. The Asian cockroach has, not surprisingly, expanded its range utilizing human transportation. Pfannenstiel et al. (2008) reported the Asian cockroach feeding on lepidopteran eggs in south Texas near the Mexican border. As it advances northward, cold temperatures only limit its range during winter.

Some basic biological studies have been conducted in the laboratory, but few field studies have been attempted (Ross and Mullins 1988, Wadleigh et al. 1989, Ross and Cochran 1995, Lawless 1999, Atkinson et al. 1999, Koehler et al. 2007). The possibility of the Asian cockroach as a pest in citrus groves was examined by Persad and Hoy (2004), and an unpublished trap efficacy study was conducted on Kiawah Island, South Carolina (Sitticharoenchai 2002). Brenner et al. (1988) examined behavior, and distribution of the Asian cockroach in a microhabitat, and found it had preferences for leaf litter and shady areas. Little is known of the habitat preferences and predator-prey interactions of the Asian cockroach in the southeastern United States. Snoddy and Appel

(2008) found that populations of the Asian cockroach started increasing in May and reached their zenith in early September. Populations of the Asian cockroach dropped dramatically with the onset of cool fall weather. At this point the Asian cockroach burrows down into the leaf litter mulch to escape extreme weather conditions (e.g., extreme temperature or relative humidity) (Snoddy and Appel 2008).

The objective of my research was to evaluate some of the elements of an Integrated Pest Management (IPM) program for the Asian cockroach. IPM programs have shown to be more effective in control of cockroaches than chemical control alone (Koehler 1999). IPM programs incorporate the use of chemical, biological, cultural, and mechanical measures to control a pest species. IPM programs are usually the most environmentally friendly programs and drastically reduce the amount of pesticide residues for humans, animals, and the environment. I evaluated the most common consumer gel and paste formulations on the market for cockroaches as well as the granular bait formulations. These experiments were conducted in the laboratory using continuous exposure experiments, Ebeling choice boxes, and repellency tests. With the results of these experiments I could identify which compounds worked best to control the Asian cockroach around the outside of the home.

I evaluated the use of one consumer granular insecticide (fipronil 0.03%), one consumer liquid insecticide (cyfluthrin 2.5 EC), and an organic liquid insecticide BASF TC-291 (30% cinnamon oil, 10% thyme oil) on field populations in Dothan, Alabama. These insecticides were applied at label rates and control was evaluated for 30 d. These are considered to be environmentally friendly insecticides and have relative low

mammalian toxicity. By evaluating the best control product for use around the home increases the success of an IPM program for the homeowner.

I also evaluated the preference of mulches of the Asian cockroach since they are peridomestic pests and found outside of homes. The Asian cockroach prefers moist leaf litter and most home in Alabama contain some type of mulch around the outside of their homes (Koehler 1999, Snoddy 2007). I used large arena boxes that contained five different mulches (topsoil, pine straw, oak leaf litter, cypress mulch, and rubber mulch). I released 100 Asian cockroaches into the large arena boxes and allowed them 7 d to acclimate and choose their preference of mulches. Mulches were then evaluated in the laboratory in Ebeling choice box for repellency, and continuous exposure tests were performed to test for toxicity on the cockroaches. By determining which mulch the Asian cockroach prefers a homeowner can alter his mulch around the home to one that is repellent to the cockroach and reduce the populations.

The Asian cockroach is a strong flyer and attracted to lights so they tend to congregate around the outside lights of a home at night and enter the home when doors or windows are opened. Once inside the house they become a nuisance by flying to television sets, reading lamps, kitchen lights (Koehler 1999). I evaluated the light preferences of the Asian cockroach to determine which lights they most prefer. By determining which lights a homeowner needs outside which will not attract Asian cockroaches could reduce the populations around the outside of the house and the number of Asian cockroaches entering the home.

## References

- Appel, A. G., M. J. Eva, E. T. Snoddy. 2009.** Distribution of the Asian cockroach, *Blattella ashinai* (Dictyoptera: Blattidae) in Dothan, Alabama. J. of Alabama Academy of Science Vol. 80, No. 1: 1-7.
- Appel, A. G., and L. M. Smith. 1996.** Harborage preferences of American and smokybrown cockroaches (Dictyoptera: Blattidae) for common landscape materials. Env. Entomol. 25: 817-824.
- Appel, A. G., and L. M. Smith. 2002.** Biology and management of the smokybrown cockroach. Annu. Rev. Entomol. 47: 33-55.
- Atkinson, T. H., P. G. Koehler, and R. S. Patterson. 1999.** Reproduction and development of *Blattella asahinai* (Dictyoptera: Blattellidae). Ann. Entomol. Soc. Am. 84: 1251-1256.
- Bell, W. J., L. M. Roth, and C.A. Nalepa. 2007.** Cockroaches- Ecology, Behavior, and Natural History. The John Hopkins University Press, Baltimore.
- Brauckmann, B., and E. Groning. 1996.** The stratigraphical position of the oldest known pterygota (Insecta, Carboniferous, Namurian). Annales de la Societe geologique de Belgique. 117: 47-56.
- Brenner, R. J., P. G. Koehler, and R. S. Patterson. 1986.** A profile of America's newest import, the Asian Cockroach. U.S. Department of Agriculture, Agricultural Research Service. [Washington, D.C.: The Service] Nov/Dec p. 17-19.
- Brenner, R. J., P. G. Koehler, and R. S. Patterson. 1988.** Ecology, behavior and distribution of *Blattella asahinai* (Orthoptera: Blattellidae) in central Florida, USA. Ann. Entomol. Soc. Am. 81: 432-436.
- Clark, J. W., S. Hossain, C. A. Burnside, and S. Kambhampati. 2001.** Coevolution between cockroach and its bacterial endosymbiont: a biogeographical perspective. Proc. R. Soc. Lond. B 268: 393-398.
- Donahoe, M. 2005.** New cockroach invades Northwest Florida. Weekly Extension New letter: #041505
- Ebeling, W. 1978.** Urban Entomology. University of California.

**Grimaldi, D., and M. S. Engel. 2005.** Evolution of the Insect. Cambridge University Press, New York, NY.

**Helfer, J. R. 1987.** How to know the grasshoppers, crickets, cockroaches, and their allies. Dover Publications, NY.

**Hennig, W. 1981.** Insect phylogeny. Wiley; Chichester, UK.

**Hu, X. P., A. G. Appel, and R. Vester. 2005.** Asian cockroach “invades” Alabama. Pest Control. JAN: 41-42.

**Klass, K. D. 1998.** The proventriculus of the dictyoptera, with comments on evolution and phylogeny in Dictyoptera and Odonata (Insecta). Zoologischer Anzeiger. 237: 15-42.

**Koehler, P. G. 1999.** Asian Cockroach. Entomology and Nematology Department, Florida Cooperative Extension Service, Institute of Food and Agricultural Sciences, University of Florida. Document ENY-202.

**Koehler, P. G., F. M. Oi, and D. Branscome. 2007.** Cockroaches and their management. University of Florida. ENY-214.

**Koehler, P. G., and R. S. Patterson. 1987.** The Asian roach invasion. Natural History. 96: 11, 28, 30, 32, 34-35.

**Kopanic, R. J., Jr., B. W. Sheldon, and C. G. Wright. 1994.** Cockroaches as vectors of Salmonella: laboratory and field trials. J. Food Prot. 57: 125-133.

**Lawless, L. S. 1999.** Morphological comparisons between two species of *Blattella* (Dictyoptera: Blattellidae). Ann. Entomol. Soc. Am. 92: 139-143.

**McKittrick, F. A. 1964.** Evolutionary studies of cockroaches. Cornell University Agricultural Experiment Station Memoir.

**Merritt, R. W. and K. W. Cummins. 1996.** An Introduction to the aquatic insects of north America. Kendall/Hunt Publishing, IA.

**Mizukubo, T. 1981.** A revision of the genus *Blattella* (Blattaria: Blattellidae) of Japan. I. Terminology of the male genitalia and description of a new species from Okinawa Island. Esakia 17: 149-159.

**Mullen, G. R., and L. Durden, 2002.** Medical and Veterinary Entomology. Elsevier Science/Academic Publishing, NY.

- Persad, A. B., and M. A. Hoy. 2004.** Predation by *Solenopsis invicta* and *Blattella asahinai* on *Toxoptera citricida* parasitized by *Lysiphlebus testaceipes* and *Lipolexis oregmae* on citrus in Florida. *Biological Control* 30: 531-537.
- Pfannenstiel, R. S., W. Booth, E. L. Vargo, and C. Schal. 2008.** *Blattella asahinai* (Dictyoptera: Blattellidae): A new predator of lepidopteran eggs in South Texas soybean. *Ann. Entomol. Soc. Am.* 101: 763-768.
- Richman, D. L. 2005.** Asian Cockroach, *Blattella asahinai* Mizukubo (Insecta: Blattodea: Blattellidae). Entomology and Nematology Department, Florida Cooperative Extension Service, Institute of Food and Agricultural Sciences, University of Florida. Document ENY-277.
- Ross, M. H., and D. G. Cochran. 1995.** The transfer of pyrethroid resistance resulting from crosses between resistant German cockroaches and susceptible Asian cockroaches. *Entomologia Experimentalis et Applicata.* 75: 83-86.
- Ross, M. H., and D. E. Mullins. 1988.** Nymphal and oothecal comparisons of *Blattella asahinai* and *Blattella germanica* (Dictyoptera: Blattellidae). *J. Econ. Entomol.* 81: 1645-1647.
- Roth, L. M. 1986.** *Blattella asahinai* introduced into Florida (Blattaria: Blattellidae). *Psyche* 93: 371-374.
- Roth, L. M., and R. H. Barth. 1954.** The reproduction of cockroaches. *Smithsonian Miscellaneous Collections.* 122: 1-49
- Roth, L. M., and E. R. Willis. 1957.** The medical and veterinary importance of cockroaches. Smithsonian Institution, Washington, DC.
- Roth, L. M., and E. R. Willis. 1960.** The biotic associations of cockroaches. Smithsonian Institution, Washington, DC.
- Roth, L. M., and E. R. Willis. 1967.** The sense organs employed by cockroaches in mating behavior. *Behaviour.* 28: 58-94.
- Rust, M. K., J. M. Owens, and D. A. Reiersen. 1995.** Understanding and controlling the German cockroach. Oxford University Press.
- Schneider, J. 1983** Die Blattodea (Insecta) des Paleozoicums, Teil I. Systematik, Ökologie und Biostratigraphie. *Freiberger Forschungshefte, Reihe C.* 382: 106-46.
- Schneider, J. 1984.** Die Blattodea (Insecta) des Paleozoicums, Teil II. Morphogenese der Flügelstrukturen und Phylogenie. *Freiberger Forschungshefte, Reihe C.* 391: 5-34.

- Sitthicharoenchai, D. 2002.** Ecology and Behavior of Asian Cockroach, *Blattella asahinai* Mizukubo (Blattodea: Blattellidae), in Charleston County, South Carolina. Clemson University dissertation, unpublished.
- Snoddy, E. T. 2007.** Distribution and population dynamics of the Asian cockroach (*Blattella asahinai* Mizukubo) in Southern Alabama and Georgia. Master of Science Thesis, Auburn University.
- Snoddy, E. T., and A. G. Appel. 2008.** Distribution of *Blattella asahinai* (Dictyoptera: Blattellidae) in Southern Alabama and Georgia. Ann. Entomol. Soc. Am. 101: 397-401.
- Snoddy, E. T., X. P. Hu and A. G. Appel. 2008.** Asian Cockroach: New pest in urban environments. Alabama Cooperative Extension System, Auburn University. Document ANR-1322.
- Tatfeng, Y. M., M. U. Usuanlele, A. Orukpe, A. K. Digban, M. Okodua, F. Oviasogi, and A. A. Turay. 2005.** Mechanical transmission of pathogenic organisms: the role of cockroaches. J. Vector Borne Diseases 42: 129-134.
- Triplehorn, C. A., and N. F. Johnson. 2005.** Borror and DeLong's Introduction to the Study of Insects. 7<sup>th</sup> ed. Thompson-Brooks/Cole. Belmont, CA.
- Wadleigh, R. W., P. G. Koehler, and R. S. Patterson. 1989.** Comparative susceptibility of North American *Blattella* (Orthoptera: Blattellidae) species to insecticides. J. Econ. Entomol. 82: 1130-1133.



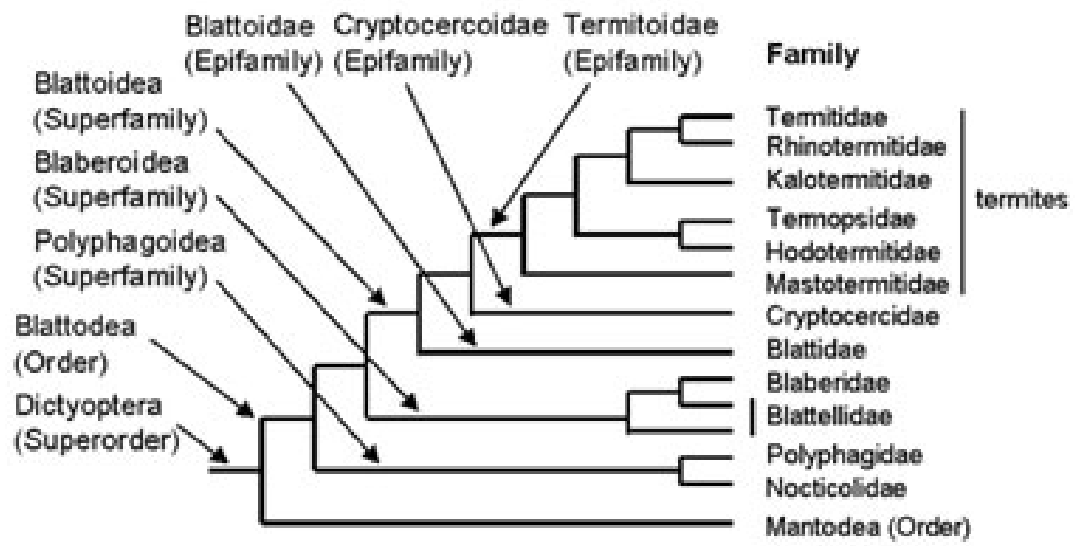

**Figure 1. Cladogram showing cockroach and termite phylogeny**



**Figure 2a. Tergal gland of adult male Asian cockroach**



**Figure 2b. Tergal gland of adult male German cockroach**



**Figure 3a. Adult male Asian cockroach (dorsal)**



**Figure 3b. Adult gravid female Asian cockroach (lateral)**

## Chapter 2

### **Performance of Consumer Insecticide Gel and Paste Formulations in Control of the Asian Cockroach *Blattella asahinai* Mizukubo (Dictyoptera: Blattellidae)**

#### **Introduction**

Insecticidal baits have become an effective alternative to traditional liquid crack and crevice sprays and aerosols for control of cockroaches inside the home (Appel 1992). For consumers, these formulations offer a safer and easier application than other household insecticides. Typically bait formulations are commercially packaged in bait stations or into syringes where they can be applied in areas that are inaccessible to children and pets (Appel 1990, 1992). However, homeowners in the southeastern United States can be faced with peridomestic cockroach species such as the smokybrown cockroach, *Periplaneta fuliginosa* (Serville) (Appel 1997, 1998) and the Asian cockroach, *Blattella asahinai* Mizukubo (Brenner et al. 1986, Koehler et al. 2007, Snoddy and Appel 2008) that have large outdoor populations and enter the home. Control of peridomestic species is different from that of domestic cockroach species because they live outdoors and environmental factors such as temperature, humidity, and rainfall affect both pest populations and insecticide residues. The most common practice is to treat the perimeter of a house with a broad spectrum residual insecticide (Koehler 1999, Appel and Smith 2002). These insecticidal barriers have numerous draw backs including rapid degradation of the insecticide during hot summer days, exposure of residues to animals and the environment, and non-discriminatory elimination of numerous beneficial

arthropods (Appel and Smith 2002). Peridomestic species live outdoors around the home and venture inside when foraging for food or attracted to house lights. These species are not limited to homes but can also affect office buildings and food establishments. Since cockroaches are omnivorous and the performance of insecticidal baits depends primarily on consumption of the bait, we compared performance of bait formulations with and without the presence of a competitive food source.

The Asian cockroach, *B. asahinai* Mizukubo, is a peridomestic pest species that was first described in 1981 from Okinawa, Japan (Mizukubo 1981), and introduced into Florida in 1986 (Roth 1986). The first account of the Asian cockroach was limited to three adjacent counties around Tampa, Florida (Brenner et al. 1986, 1988); as of 2007, all 67 Florida counties have established populations (P.G. Koehler, personal communication). In early 2003, the Asian cockroach was identified for the first time outside of Florida in Dothan, Alabama (Hu et al. 2005). Currently these cockroaches are distributed in seven counties in Alabama and eight counties in Georgia (Snoddy 2007, Snoddy and Appel 2008). In 2008, the cockroach was reported in south a Texas soybean field (Pfannenstiel et al. 2008).

Several basic biological studies have been conducted in the laboratory, but few field studies have been attempted (Ross and Mullins 1988, Lawless 1999, Brenner et. al. 1988, Atkinson et. al. 1999). The Asian cockroach is a small (< 25 mm) species that is similar in appearance to the German cockroach, *Blattella germanica* (L.). The German cockroach is a domestic pest that only lives indoors, does not fly, and is negatively phototactic (Ebeling 1978, Rust et al. 1995). In contrast, Asian cockroaches live outdoors as a peridomestic pest, is a strong flyer, and positively phototactic in the evening (Brenner

et. al. 1988, Snoddy and Appel 2008). The Asian cockroach is attracted to lights and often enters homes where it becomes a nuisance flying to reading lamps, television sets, kitchen lights, etc. (Brenner et al. 1988). It can therefore be confused with a German cockroach if proper identification is not made. Misidentification can lead to unnecessary indoor treatments that are ineffective and can expose humans and pets to unnecessary pesticide residues. The Asian cockroach lives outdoors so it is in contact with animal feces and a variety of soil pathogens. This species can mechanically vector pathogens such as *Salmonella spp.* by physically contaminating food or food preparation surfaces (Roth and Willis 1957, 1960, Kopanic et al. 1994, Tاتفeng et al. 2005). Cockroach feces and body parts can be allergenic to sensitive individuals (Ebeling 1978, Schal and Hamilton 1990). In some cases this can be life-threatening to sensitive individuals (Ebeling 1978, Schal and Hamilton 1990).

The objective of this study was to determine the toxicity of insecticide gels and baits that are currently available to the homeowner for control of the Asian cockroach. There is little information on the toxicity and performance of modern insecticidal bait formulations against the Asian cockroach. We evaluated bait toxicity with and without competitive food because peridomestic cockroaches have many food choices around the home. German cockroach research has shown that effective bait formulations must be palatable and relatively non-repellent, readily available, and toxic in the amounts consumed by the cockroach (Reierson and Rust 1984, Appel 1990, Appel 1992). Once the most efficacious formulations have been indentified they could be incorporated into an Integrated Pest Management (IPM) program that would increase control of the Asian



cockroach and reduce the exposure of homeowners, animals and the environment to insecticidal residues.

## **Materials and Methods**

**Insects.** The Asian cockroaches used in this study were originally collected in 2010 in Dothan (Houston County), Alabama (31°15'16.24"N, 85°24'52.56"W). Colonies were maintained in 7.6 L (gallon) glass jars with water oak, *Quercus nigra* L., leaves and 140 cm<sup>2</sup> cardboard harborages at 25 ± 2°C and 40-55% RH, exposed to a photoperiod of 12:12 (L:D) h, and supplied water and dry dog chow (Purina Dog Chow, Ralston Purina, St. Louis, MO.) ad libitum. Cockroaches were briefly anesthetized with CO<sub>2</sub> to facilitate handling. Adult males were used for all tests because of their more uniform weight and physiology relative to nymphs or adult females (Appel et al. 1983).

**Insecticides.** The toxicity of seven commercially available gel and paste bait formulations were evaluated: Advion<sup>®</sup> (indoxacarb 0.60%), Avert<sup>®</sup> (abamectin B1 0.05%), Combat<sup>®</sup> Quick Kill (fipronil 0.03%), Combat<sup>®</sup> Ready Kill (hydramethylnon 2.15%), Combat<sup>®</sup> Ready Kill Gel (hydramethylnon 2.0%), Hot Shot<sup>®</sup> Ultra Clear<sup>™</sup> (dinotefuran 0.05%), and Pre-Empt<sup>®</sup> (imidacloprid 2.15%), (Table 1). Dry dog chow (Purina Dog Chow, Ralston Purina, St. Louis, MO.) was used as control and competitive food.

**Continuous Exposure Test.** Six adult males were confined in a 0.95 L glass jar with a 75 ml vial of water with a cotton wick inserted through the cap, a 40 cm<sup>2</sup> cardboard harborage (Appel 1992), and starved for 24 h. Petroleum jelly was used to lightly coat the upper inside surface of the jar, and filter paper covers secured with metal

bands prevented cockroach escape. Insecticidal gels and paste baits were placed in pre-weighed 1.5 ml microcentrifuge tubes (Fisherbrand<sup>®</sup>, 02-681-272) reweighed and introduced into the glass jars. Treatments that contained preweighed competitive food choices (Dog Chow) were also included to determine the gel baits and pastes palatability to cockroaches. Cockroaches were allowed to feed on insecticidal gels and mortality data was recorded every 12 h. Data were recorded for 14 d or until all the cockroaches in a jar died. Jars containing dog chow alone served as the untreated control. Tubes containing bait and dog chow were reweighed after 48 h to determine consumption. Baits and dog chow were placed into jars without cockroaches and reweighed after 48 h to determine evaporation. All test treatments and controls were replicated six times in a completely randomized design. Jars were maintained at  $25 \pm 2^\circ\text{C}$ , 40-55% RH, and exposed to a photoperiod of 12:12 (L:D) h.

**Data Analysis.** Mortality ( $LT_{50}$ ) in the continuous exposure tests was analyzed by probit analysis for correlated data (Throne et al. 1995) because multiple observations were taken on the same individuals (SAS 2011). Significant differences  $LT_{50}$  values were based on non-overlap of the 95% confidence intervals (CI). Descriptive analysis was used to determine mean consumption of baits with and without competitive food (Systat Systems 2011). Analysis of variance was used to compare consumption among baits (Systat Systems 2011).

## **RESULTS**

**Continuous Exposure.** In continuous exposure experiments without competitive food,  $LT_{50}$  values (with CI) for gel and paste baits ranged from 0.49 (0.00-0.00) d to 8.01

(6.99-9.44) d for Advion<sup>®</sup> and Combat<sup>®</sup> Ready Kill Gel, respectively (Table 2). In continuous exposure experiments with a competitive food source  $LT_{50}$ s for gel and paste baits ranged from 0.025 (0.023-0.088) d for Advion<sup>®</sup> to 452 (452-343,950) d for Combat<sup>®</sup> Ready Kill Gel (Table 2). The control, both without and with a competitive food source, had an  $LT_{50}$  values of >1000 d, or the maximum life time of this species. Evaporation of insecticidal gels and baits at 48 h ranged from a mass (water) loss of  $0.0 \pm 0.00$  to  $14.3 \pm 0.1\%$  for Dog Chow and Advion, respectively (Table 3). Evaporation was used to correct for water loss when calculating consumption of baits by cockroaches. Consumption of gel or paste baits without competitive food ranged from  $0.0114 \pm 0.0016$  g for Combat<sup>®</sup> Quick Kill to  $0.0516 \pm 0.0123$  for Hot Shot<sup>®</sup> Ultra Kill (Table 3). Consumption of gel or paste baits with competitive food ranged from  $0.0019 \pm 0.0526$  g to  $0.0893 \pm 0.0024$  g for Combat<sup>®</sup> Ready Kill and Advion<sup>®</sup>, respectively (Table 3).

## **DISCUSSION**

Insecticidal gels and paste baits have become an effective alternative to traditional liquid crack and crevice sprays for control of German cockroaches inside the home (Appel 1992). Typically these gels and pastes are commercially packaged into bait stations or more commonly syringes where they are designed to be used in the home and can be placed where they are inaccessible to children and pets (Appel 1990, 1992). In recent years IPM programs have been shown to be the most effective method of cockroach control with chemical methods alone being the least effective (Appel and Smith 2002, Koehler et al. 2007). The most common practice for peridomestic cockroach control is to treat a perimeter around the house using a broad spectrum residual

insecticide (Appel and Smith 2002, Koehler 1999). Insecticidal barriers have numerous draw backs including rapid degradation of the insecticide during hot summer days, exposure of residues to animals and the environment, and non-discriminatory elimination of numerous beneficial arthropods (Appel and Smith 2002). Peridomestic species live outdoors around the home and venture inside when foraging for food or attracted to house lights. Control measures for peridomestic cockroaches must be targeted outside where these species live and reproduce. Bait products can be applied in a variety of outdoor locations and are generally less toxic and more specific than broad spectrum insecticides.

Advion<sup>®</sup> was the most toxic insecticide formulation to the Asian cockroach and increased efficacy was achieved in the presence of competitive food. It is possible that Advion<sup>®</sup> stimulated feeding on dog chow, resulting in faster movement of Advion<sup>®</sup> into the digestive system. Increased efficacy of insecticides presented with competitive food sources has been observed before (Appel 1992). Advion<sup>®</sup> would be a good choice as part of an IPM program for the Asian cockroach because of its fast action and relatively low mammalian toxicity ( $LD_{50} < 1000$  mg/kg oral and  $> 5000$  mg/kg dermal, rat) and “reduced risk” EPA classification (U.S. EPA, Pesticide fact sheet, indoxacarb, October 13, 2000). All of the Combat<sup>®</sup> products had acceptable control ( $LT_{50} < 8$  d) when presented without a competitive food source (Table 2). But when Combat<sup>®</sup> products were presented with a competitive food source (dog chow) their control decreased significantly (Table 2). This could be due in part to the palatability of the Combat<sup>®</sup> products; if the cockroaches had nothing else to eat then they consumed the products and died, if they had an alternative they preferred not to eat the Combat<sup>®</sup> products resulting in poor control. Combat<sup>®</sup> products evaluated in this experiment could not be considered good choices for use in an

IPM program for the Asian cockroach. Hot Shot<sup>®</sup> Ultra Kill and Pre-Empt<sup>®</sup> had very similar LT<sub>50</sub> values in experiments with and without competitive food but still did not perform as well as the Advion<sup>®</sup> product.

We also examined the effects of starvation with and without water. When dog chow alone was presented to the Asian cockroach, LT<sub>50</sub> values were much lower indicating the physiological need for water during digestion. As a peridomestic pest around homes, it is impractical to consider starvation of Asian cockroaches as a control method or even an IPM tactic.

In conclusion, gels and paste baits must be applied around the outside of the home in areas that are protected from the elements and not readily accessible to humans and animals but accessible to the Asian cockroach. Areas such as under window ledges, soffits, light fixtures, and along bases of doors and windows would be appropriate. Also areas such as landscaping fixtures, lighted lamp posts, and out buildings should be included when applying baits. Of the insecticides evaluated in this experiment the most effective compound was Advion<sup>®</sup> and it could be incorporated into an IPM program that would increase control of the Asian cockroach and reduce exposure of homeowners, animals and the environment to insecticidal residues.

## References

- Appel, A. G. 1990.** Laboratory and field performance of consumer bait formulations for German cockroach (Dictyoptera: Blattellidae) control. *J. Econ. Entomol.* 83: 153-159.
- Appel, A. G. 1992.** Performance of gel and paste bait products for German cockroach (Dictyoptera: Blattellidae) control: laboratory and field studies. *J. Econ. Entomol.* 85: 1176-1183.
- Appel, A. G. 1997.** Nonchemical approaches to cockroach control. *J. Agric. Entomol.* 14: 271-280.
- Appel, A. G. 1998.** Comparison of conventional and targeted insecticide application for control of smokybrown cockroaches (Dictyoptera: Blattellidae) in three urban areas of Alabama. *J. Econ. Entomol.* 91: 473-479.
- Appel, A. G., D. A. Reirson and M. K. Rust. 1983.** Comparative water relations and temperature sensitivity of cockroaches. *Comp. Biochem. Physiol. A Comp. Physiol.* 74: 357-361.
- Appel, A. G., and L. M. Smith. 2002.** Biology and management of the smokybrown cockroach. *Annu. Rev. Entomol.* 47: 33-55.
- Atkinson, T. H., P. G. Koehler, and R. S. Patterson. 1999.** Reproduction and development of *Blattella asahinai* (Dictyoptera: Blattellidae). *Ann. Entomol. Soc. Am.* 84: 1251-1256.
- Brenner, R. J., P. G. Koehler, and R. S. Patterson. 1986.** A profile of America's newest import, the Asian Cockroach. U.S. Department of Agriculture, Agricultural Research Service. [Washington, D.C.: The Service] Nov/Dec p. 17-19.
- Brenner, R. J., P. G. Koehler, and R. S. Patterson. 1988.** Ecology, behavior and distribution of *Blattella asahinai* (Orthoptera: Blattellidae) in central Florida, USA. *Ann. Entomol. Soc. Am.* 81: 432-436.
- Ebeling, W. 1978.** Urban Entomology. University of California.
- Hu, X. P., A. G. Appel, and R. Vester. 2005.** Asian cockroach "invades" Alabama. *Pest Control. JAN* 41-42.

- Koehler, P. G. 1999.** Asian Cockroach. Entomology and Nematology Department, Florida Cooperative Extension Service, Institute of Food and Agricultural Sciences, University of Florida. Document ENY-202.
- Koehler, P. G., F. M. Oi, and D. Branscome. 2007.** Cockroaches and their management. University of Florida. ENY-214.
- Kopanic, R. J., Jr., B. W. Sheldon, and C. G. Wright. 1994.** Cockroaches as vectors of Salmonella: laboratory and field trials. *J. Food Prot.* 57: 125-133.
- Lawless, L. S. 1999.** Morphological comparisons between two species of *Blattella* (Dictyoptera: Blattellidae). *Ann. Entomol. Soc. Am.* 92: 139-143.
- Mizukubo, T. 1981.** A revision of the genus *Blattella* (Blattaria: Blattellidae) of Japan. I. Terminology of the male genitalia and description of a new species from Okinawa Island. *Esakia* 17: 149-159
- Pfannenstiel, R. S., W. Booth, E. L. Vargo, and C. Schal. 2008.** *Blattella asahinai* (Dictyoptera: Blattellidae): A new predator of lepidopteran eggs in South Texas soybean. *Ann. Entomol. Soc. Am.* Vol. 101, no 4: 763-768.
- Reierson, D. A., and M. K. Rust. 1984.** Insecticidal baits and repellency in relation to control of the German cockroach, *Blattella germanica* (L.). *Pest Manage.* 3: 26-32.
- Ross, M. H., and D. E. Mullins. 1988.** Nymphal and oothecal comparisons of *Blattella asahinai* and *Blattella germanica* (Dictyoptera: Blattellidae). *J. Econ. Entomol.* 81: 1645-1647.
- Roth, L. M. 1986.** *Blattella asahinai* introduced into Florida (Blattaria: Blattellidae). *Psyche* 93: 371-374.
- Roth, L. M., and E. R. Willis. 1957.** The medical and veterinary importance of cockroaches. Smithsonian Institution, Washington, DC.
- Roth, L. M., and E. R. Willis. 1960.** The biotic associations of cockroaches. Smithsonian Institution, Washington, DC.
- Rust, M. K., J. M. Owens, and D. A. Reierson. 1995.** Understanding and controlling the German cockroach. Oxford University Press.
- SAS Institute. 2011.** SAS 9.1 Statistical analysis software. SAS Institute, Cary, NC.
- Schal, C., and R. L. Hamilton. 1990.** Integrated suppression of synanthropic cockroaches. *Annu. Rev. Entomol.* 35: 521-551.

**Snoddy, E. T. 2007.** Distribution and population dynamics of the Asian cockroach (*Blattella asahinai* Mizukubo) in Southern Alabama and Georgia. Master of Science Thesis, Auburn University.

**Snoddy, E. T., and A. G. Appel. 2008.** Distribution of *Blattella asahinai* (Dictyoptera: Blattellidae) in Southern Alabama and Georgia. *Ann. Entomol. Soc. Am.* 101: 397-401.

**Systat Software, Inc. 2011.** SigmaPlot for Windows, version 12.2. Systat Software, Inc., San Jose, CA.

**Tatfeng, Y. M., M. U. Usuanlele, A. Orukpe, A. K. Digban, M. Okodua, F. Oviasogi, and A. A. Turay. 2005.** Mechanical transmission of pathogenic organisms: the role of cockroaches. *J. Vector Borne Diseases.* 42: 129-134.

**Throne, J. E., D. K. Weaver, V. Chew, and J. E. Baker. 1995.** Probit analysis of correlated data: multiple observations over time at one concentration. *J. Econ. Entomol.* 88: 1510-1512.



**Table 1. Gel insecticides used in the evaluation of the Asian cockroach toxicity experiments.**

Treatment	Compound	% AI <sup>a</sup>	Manufacturer	City, State	EPA Reg. No. <sup>b</sup>
Advion	indoxacarb	0.60%	DuPont	Wilmington, DE.	352-746
Avert	abamectin B <sub>1</sub>	0.05%	BASF	St. Louis, MO.	499-507
Combat Quick Kill	fipronil	0.03%	Combat ICS	Scottsdale, AZ.	64248-12
Combat Ready Kill	hydramethylnon	2.15%	Combat ICS	Scottsdale, AZ.	64240-35
Combat Ready Kill Gel	hydramethylnon	2.0%	Combat ICS	Scottsdale, AZ.	64240-35
Hot Shot Ultra Clear	dinotefuran	0.05%	Spectrum Group	St. Louis, MO.	9688-271-8845
Pre-Empt	imidacloprid	2.15%	Bayer	Kansas City, MO.	3125-525

<sup>a</sup> %AI = percentage of active ingredient,

<sup>b</sup> EPA Reg. No. = Environmental Protection Agency registration number.

**Table 2. Toxicity of gel insecticides with and without competitive food to adult male Asian cockroaches in continuous exposure experiments.**

Treatment	Food <sup>a</sup>	n	Slope $\pm$ SE	LT <sub>50</sub> (95% CI)	$\chi^2$	P
Advion	No	6	23.00 $\pm$ 0.71	<1.00	-	-
	Yes	6	3.47 $\pm$ 1.26	<1.00	7.57	0.0060
Avert	No	6	2.97 $\pm$ 0.37	2.18 (1.69-2.63)	64.60	<0.0001
	Yes	6	3.98 $\pm$ 0.32	4.61 (4.19-5.04)	147.56	<0.0001
Combat QF	No	6	4.13 $\pm$ 0.38	3.58 (3.19-3.96)	116.67	<0.0001
	Yes	6	1.58 $\pm$ 0.23	7.55 (6.11-9.89)	46.70	<0.0001
Combat R	No	6	1.95 $\pm$ 0.19	1.07 (0.78-1.35)	99.70	<0.0001
Kill	Yes	6	2.14 $\pm$ 0.27	7.60 (6.48-9.19)	62.76	<0.0001
	Combat R	No	6	2.45 $\pm$ 0.27	8.01 (6.99-9.44)	80.02
Kill Gel	Yes	6	0.81 $\pm$ 0.25	452 (86-343950)	10.46	0.0012
	Dog Chow	No	6	0.59 $\pm$ 0.23	1175 (107-3.24 <sup>11</sup> )	6.38
Yes		6	0.59 $\pm$ 0.23	1175 (107-3.24 <sup>11</sup> )	6.38	0.0115
Hot Shot	No	6	2.57 $\pm$ 0.25	3.03 (2.54-3.51)	102.37	<0.0001
Ultra Kill	Yes	6	2.19 $\pm$ 0.27	5.42 (4.57-6.42)	64.40	<0.0001
	PreEmpt	No	6	3.06 $\pm$ 0.28	3.21 (2.78-3.63)	117.69
Yes		6	2.95 $\pm$ 0.24	5.20 (4.70-5.74)	145.60	<0.0001
Starve	No	6	4.68 $\pm$ 0.59	7.25 (6.49-8.14)	61.86	<0.0001

Yes	6	4.74 ± 0.36	2.92 (2.67-3.61)	167.61	<0.0001
-----	---	-------------	------------------	--------	---------

---

<sup>a</sup> Food is defined as no = no competitive food source, yes = competitive food source (Dog Chow).

**Table 3. Mean ( $\pm$  SE) consumption of gel and paste baits with and without competitive food with adult male Asian cockroaches in continuous exposure experiments.**

Treatment	Food <sup>a</sup>	n	% H <sub>2</sub> O loss in first 48 h	Consumption (g) in first 48 h
Advion	No	6	14.3 $\pm$ 0.1	0.0210 $\pm$ 0.0868
	Yes	6	14.3 $\pm$ 0.1	0.0893 $\pm$ 0.0024
Avert	No	6	7.0 $\pm$ 0.1	0.0138 $\pm$ 0.0033
	Yes	6	7.0 $\pm$ 0.1	0.0207 $\pm$ 0.0008
Combat QF	No	6	0.0 $\pm$ 0.0	0.0114 $\pm$ 0.0016
	Yes	6	0.0 $\pm$ 0.0	0.0227 $\pm$ 0.0006
Combat R Kill	No	6	0.0 $\pm$ 0.1	0.0126 $\pm$ 0.0048
	Yes	6	0.0 $\pm$ 0.1	0.0019 $\pm$ 0.0526
Combat R Kill Gel	No	6	9.0 $\pm$ 0.0	0.0220 $\pm$ 0.0047
	Yes	6	9.0 $\pm$ 0.0	0.0174 $\pm$ 0.0006
Dog Chow	No	6	0.0 $\pm$ 1.0	0.0265 $\pm$ .0043
	Yes	6	0.0 $\pm$ 1.0	0.0265 $\pm$ .0043
Hot Shot Ultra Kill	No	6	12.8 $\pm$ 1.9	0.0516 $\pm$ 0.0123
	Yes	6	12.8 $\pm$ 1.9	0.0748 $\pm$ 0.0223
PreEmpt	No	6	8.0 $\pm$ 1.2	0.0211 $\pm$ 0.0200
	Yes	6	8.0 $\pm$ 1.2	0.0192 $\pm$ 0.0323

<sup>a</sup> Food is defined as no = no competitive food source, yes = competitive food source (Dog Chow).

## Chapter 3

### Performance of Consumer Granular Bait Formulations in Control of the Asian Cockroach *Blattella asahinai* Mizukubo (Dictyoptera: Blattellidae)

#### Introduction

There are numerous arthropods that live outside and around the home in most urban environments (peridomestic pests). Eventually, some of these arthropods may end up inside the home as unwanted pests of homeowners. One peridomestic cockroach species that can have large populations in the Southeastern U.S. is the Asian cockroach (Koehler et al. 2007). The Asian cockroach, *Blattella asahinai* Mizukubo, is a peridomestic pest species from Okinawa, Japan that was first described in 1981 (Mizukubo 1981), and introduced into Florida in 1986 (Roth 1986). The first report of the Asian cockroach was limited to three adjacent counties around Tampa Florida (Brenner et al. 1986, Koehler and Patterson 1987, Brenner et al. 1988); as of 2007, all 67 Florida counties have established populations (P.G. Koehler, personal communication). In early 2003, the Asian cockroach was identified for the first time outside of Florida in Dothan, Alabama (Hu et al. 2005). Currently these cockroaches are distributed in seven counties in Alabama and eight counties in Georgia (Snoddy 2007, Snoddy and Appel 2008). In 2008, the cockroach was reported in south Texas soybean fields (Pfannenstiel et al. 2008).

Homeowners have several granular insecticides with which they can treat outside the home and landscape to control peridomestic pests (Koehler et al. 2007). The most

common practice is to treat a perimeter around the house with a broad spectrum residual insecticide (Appel and Smith 2002, Koehler 1999). These insecticidal barriers have numerous draw backs including rapid degradation of the insecticide during hot summer days, exposure of residues to animals and the environment, and non-discriminatory elimination of numerous beneficial arthropods (Appel and Smith 2002). In recent years the EPA has withdrawn registrations of many homeowner used insecticides. Newer compounds low in mammalian toxicity and environmentally friendly have replaced these older compounds. Insecticide granular baits have become an effective alternative to traditional liquid sprays in control of arthropods around the outside of the home (Koehler et al. 2007). For example, many homeowners are currently using a variety of fire ant baits around the home for control of the Red Imported Fire Ant, *Solenopsis invicta* Buren. For consumers these granular bait formulations offer an easier application approach to control of arthropods around the home. Typically these granules come in prepackaged jugs that have shaker tops so the consumer can just sprinkle the insecticide granular bait out onto the ground. These formulations are generally not selective in the arthropods they control.

Control of peridomestic cockroach species is different from that of domestic species because of effects of the environment such as rain, sun light, and humidity. Since the Asian cockroach lives outdoors it is in contact with animal feces and several soil pathogens. This species can mechanically vector pathogens such as *Salmonella spp.* by physically contaminating food or food preparation surfaces (Roth and Willis 1957, 1960, Kopanic et al. 1994, Tatfeng et al. 2005). Cockroach feces and body parts can be allergenic to sensitive individuals (Ebeling 1978, Schal and Hamilton 1990). In some

cases this can be life-threatening to sensitive individuals (Ebeling 1978, Schal and Hamilton 1990).

The objective of this study was to determine the toxicity of currently available insecticide granular baits for control of the Asian cockroach. We evaluated insecticide performance of these baits with and without competitive food since peridomestic cockroaches have many potential food choices around the home. Effective bait formulations must be palatable and relatively non-repellent, readily available, and toxic in the quantities consumed by the cockroach (Reiersen and Rust 1984, Appel 1990, 1992). Once the most toxic baits have been identified they can be incorporated into an Integrated Pest Management (IPM) program that would increase control of the Asian cockroach and reduce exposure of homeowners, animals, and environment to insecticidal residues.

## **Materials and Methods**

**Insects.** The Asian cockroaches used in this study were collected in Dothan (Houston County), Alabama (31°15'16.24"N, 85°24'52.56"W). Colonies were maintained in 3.8 L (1 gallon) glass jars with water oak, *Quercus nigra* L., leaves and 140 cm<sup>2</sup> cardboard harborages at 25 ± 2°C and 40-55% RH, exposed to a photoperiod of 12:12 (L:D) h, and supplied water and dry dog chow (Purina Dog Chow, Ralston Purina, St. Louis, MO.) ad libitum. Cockroaches were anesthetized with CO<sub>2</sub> to facilitate handling. Adult males were used for all tests because of their more uniform weight and physiology relative to nymphs or adult females (Appel et al. 1983).

**Insecticides.** The toxicity of nine granular consumer insecticides were evaluated; Amdro® (hydamethylnon 0.73%), Grant's® Kills Ants (arsenic trioxide 0.46%), InTice® (orthoboric acid 5.0%), MaxForce® (imidacloprid 0.50%), Mint Oil Granules (mint oil 2.0%), Mother Earth® (boric acid 5.0%), Niban® (orthoboric acid 5.0%), OverNOut® (fipronil 0.0103%), and Safer® Fire Ant Bait (spinosad 0.015%) (Table 1). Purina Dog Chow was used as a control and competitive food (Table 1).

**Continuous Exposure Test.** Six adult males were confined in a 0.95 L glass jar with a 75 ml vial of water with a cotton wick inserted through the cap, a 40 cm<sup>2</sup> cardboard harborage (Appel 1992), and starved for 24 h. Petroleum jelly was used to lightly coat the upper inside surface of the jar, and filter paper covers secured with metal bands prevented cockroach escape. Insecticide granular baits were placed in 1.5 ml microcentrifuge tubes (Fisherbrand®, 02-681-272) and introduced into the glass jar. We also included treatments that contained competitive food (dog chow) to estimate the palatability of the granular baits. Cockroaches were allowed to feed on insecticidal granular baits and mortality data was recorded every 12 h. Data were recorded for 14 h or until all the cockroaches in a jar died. There were six replicated jars for every bait and competitive food combination. The masses of each bait and any competitive food were recorded at the beginning of the experiment and again after 48 h. Bait mass losses in jars without cockroaches were used to correct consumption data. Control jars contained no insecticide. All test treatments and controls were replicated six times in a completely randomized design. Jars were kept in a room at 25 ± 2°C, 40-55% RH, and exposed to a photoperiod of 12:12 (L:D) h. The number of live and dead cockroaches in each jar was recorded daily 3-4 h into the photophase for 14 d.



**Data Analysis.** Mortality (LT<sub>50</sub>) in the continuous exposure tests were analyzed by probit analysis for correlated data (Throne et al. 1995) because multiple observations were taken on the same individuals (SAS 2011). Significant differences LT<sub>50</sub> values were based on non-overlap of the 95% confidence intervals (CI). Descriptive analysis was used to determine mean consumption of baits with and without competitive food (Systat Systems 2011). Analysis of variance was used to compare consumption among baits (Systat Systems 2011).

## RESULTS

**Continuous Exposure.** In continuous exposure experiments without competitive food LT<sub>50</sub> values for granular baits ranged from 1.07 to 63.21 d for MaxForce<sup>®</sup> and Safer<sup>®</sup> Fire Ant Bait, respectively (Table 2). In continuous exposure experiments with competitive food LT<sub>50</sub> values ranged from 1.37 d for OverNOut<sup>®</sup> to 452 d for mint oil granules (Table 2). The untreated control (without and with competitive food) had an LT<sub>50</sub> value of 1175 (107-3.24<sup>11</sup>) d or >3 yr. OverNOut<sup>®</sup> bait had the least difference in LT<sub>50</sub> values with and without competitive food (Table 2). Mint oil granules had the highest difference in LT<sub>50</sub> values with and without competitive food (Table 2). Most treatments had an increase in LT<sub>50</sub> value when the cockroaches were presented bait with a competitive food (Table 2). Evaporation of insecticidal granular baits at 48 h ranged from 0-2% for Dog Chow and Grant's<sup>®</sup> Ant Killer, respectively (Table 3). Evaporation was used to correct for water loss when calculating bait consumption. Consumption of granular baits without competitive food ranged from 0.0214 to 0.0839 g for Amdro<sup>®</sup> and Grant's<sup>®</sup> Ant Killer, respectively (Table 3). Consumption of granular baits with a

competitive food ranged from 0.0057 g for Amdro<sup>®</sup> to 0.0069 g for Safer<sup>®</sup> Fire Ant Killer (Table 3).

## **DISCUSSION**

Granular insecticidal baits have become an effective alternative to traditional liquid sprays in control of arthropods around the outside of the home (Koehler et al. 2007). For consumers, these granular bait formulations offer an easier application and effective control. The homeowner in the Southeastern United States can be faced with peridomestic cockroach species such as the smokybrown cockroach, *Periplaneta fuliginosa* (Serville), (Appel 1997, 1998) and the Asian cockroach, *Blattella asahinai* Mizukubo (Brenner et al. 1986, Koehler et al. 2007, Snoddy 2007, Snoddy and Appel 2008) can develop large populations outdoors and enter the home. Peridomestic species may venture indoors when foraging for food or attracted to lights. Control measures must be targeted outside for the peridomestic cockroach species where they live and reproduce. IPM programs are the most effective methods for peridomestic cockroach (Appel and Smith 2002, Koehler et al. 2007). IPM programs involve not only a chemical component but also biological, cultural, and mechanical components. For example, a homeowner can alter the type and placement of mulch around the home to help control peridomestic cockroaches (Koehler et al. 2007, Snoddy and Appel 2011, unpublished data).

The purpose of this study was to determine the effectiveness of several granular insecticide baits available to the homeowner for control of the Asian cockroach. Since this species is a relatively new and invasive pest (Snoddy and Appel 2008) there has been little research to evaluate the most effective and environmentally friendly insecticides and

formulations. We evaluated granular bait performance with and without a competitive food since peridomestic cockroaches have many potential food choices around the home such as pet food and feces, trash, flowers, etc. Effective bait formulations must be palatable and relative non-repellent, readily available, and toxic in the amounts consumed by the cockroach (Reierson and Rust 1984, Appel 1990, Appel 1992). Koehler (1999) reported that in Florida the Asian cockroach is susceptible to most insecticides which is in contrast to the closely related German cockroach, *B. germanica* (L.), which has developed resistance to numerous insecticides (Ebeling 1978, Cochran 1982, 1984). The Asian cockroach is closely related to the German cockroach, so it is quite likely that this species will also to develop insecticide resistance after repeated exposure; therefore, a multi-tactic IPM program is needed for long-term management of this pest.

OverNOut<sup>®</sup> (fipronil 0.0103%) granular insecticide bait had the most consistent control toxicity against the Asian cockroach when presented with or without competitive food (Table 2). This result is consistent with field experiments using OverNOut<sup>®</sup> conducted in two locations in Dothan, AL in 2011 for control of Asian cockroaches (Snoddy and Appel 2011, unpublished data). MaxForce<sup>®</sup> granular baits had the lowest LT<sub>50</sub> value when presented without competitive food, but when cockroaches were offered a competitive food, the LT<sub>50</sub> value increased six fold, indicating a lack of palatability to the bait. MaxForce<sup>®</sup> had a very pungent smell and it would be impracticable to consider it for use around the home. The boric acid compounds (Table 1, Table 2) also had LT<sub>50</sub> values that increased when cockroaches were offered competitive food. Although these boric acid compounds are environmentally friendly, they tend to break down quickly and leach in the soil; they would therefore not be a good choice in an IPM program. Mint oil

granules  $LT_{50}$  values were  $>8$  d and not acceptable as a fast kill control product. However, they would offer a homeowner an environmentally safe OMRI product that would have limited pesticide residues. Safer<sup>®</sup> Fire Ant Bait (spinosad 0.015%) had poor control of the Asian cockroach ( $LT_{50} = 63$  d) when presented alone and had a four-fold increase in  $LT_{50}$  value when offered competitive food. Although spinosad is a safe insecticide (no dermal or systemic toxicity in 21- d rabbit exposure of  $1000 \text{ mg kg}^{-1} \text{ d}^{-1}$ , U. S. EPA, Pesticide fact sheet, spinosad, May 1997) it would not be a good choice in an IPM program. We also examined starvation of Asian cockroaches where no water or dog chow was presented and starvation where only dog chow was presented. Where dog chow alone was presented the Asian cockroach had a lower  $LT_{50}$ , demonstrating the physiological need for water to digest food. As a peridomestic pest around homes it is impractical to consider trying to starve the Asian cockroach as a means of control or even incorporate it into an IPM program. But, elimination of as many possible food sources around the home is still advisable.

In conclusion, granular baits must be applied around the outside of the home in areas where they are accessible and in close proximity to populations the Asian cockroach (Koehler 1999, Appel and Smith 2002). Of the insecticides evaluated in this study the most effective was OverNOut<sup>®</sup> (fipronil 0.0103%), and could be incorporated into an IPM program that would increase control of the Asian cockroach. Since the OverNOut<sup>®</sup> (fipronil 0.0103%) has low mammalian toxicity (acute oral  $LD_{50} >5000$  mg/kg rat, U.S. EPA, Pesticide fact sheet, fipronil, May 1996); critical placement of the granular bait around the home could reduce exposure of homeowners, animals and the environment to insecticidal residues.

## References

- Appel, A. G. 1990.** Laboratory and field performance of consumer bait formulations for German cockroach (Dictyoptera: Blattellidae) control. J. Econ. Entomol. 83: 153-159.
- Appel, A. G. 1992.** Performance of gel and paste bait products for for German cockroach (Dictyoptera: Blattellidae) control: laboratory and field studies. J. Econ. Entomol. 85: 1176-1183.
- Appel, A. G. 1997.** Nonchemical approaches to cockroach control. J. Agric. Entomol. 14: 271-280.
- Appel, A. G. 1998.** Comparison of conventional and targeted insecticide application for control of smokybrown cockroaches (Dictyoptera: Blattidae) in three urban areas of Alabama. J. Econ. Entomol. 91: 473-479.
- Appel, A. G., D. A. Reirson and M. K. Rust. 1983.** Comparative water relations and temperature sensitivity of cockroaches. Comp. Biochem. Physiol. A Comp. Physiol. 74: 357-361.
- Appel, A. G., and L. M. Smith. 2002.** Biology and management of the smokybrown cockroach. Annu. Rev. Entomol. 47: 33-55.
- Brenner, R. J., P. G. Koehler, and R. S. Patterson. 1986.** A profile of America's newest import, the Asian Cockroach. U.S. Department of Agriculture, Agricultural Research Service. [Washington, D.C.: The Service] Nov/Dec p. 17-19.
- Brenner, R. J., P. G. Koehler, and R. S. Patterson. 1988.** Ecology, behavior and distribution of *Blattella asahinai* (Orthoptera: Blattellidae) in central Florida, USA. Ann. Entomol. Soc. Am. 81: 432-436.
- Cochran, D. G. 1982.** German cockroach resistance: new mode of action could stalemate resistance. Pest Control 50: 16, 18, 20.
- Cochran, D. G. 1984.** Insecticide resistance in cockroaches: is it at a crossroads? Pest Manage. 3: 26-31.
- Ebeling, W. 1978.** Urban Entomology. University of California.

**Hu, X. P., A. G. Appel, and R. Vester. 2005.** Asian cockroach “invades” Alabama. Pest Control. JAN: 41-42.

**Koehler, P.G. 1999.** Asian Cockroach. Entomology and Nematology Department, Florida Cooperative Extension Service, Institute of Food and Agricultural Sciences, University of Florida. Document ENY-202.

**Koehler, P. G., F. M. Oi, and D. Branscome. 2007.** Cockroaches and their management. University of Florida. ENY-214.

**Koehler, P. G., and R. S. Patterson. 1987.** The Asian roach invasion. Natural History. 96: 11, 28, 30, 32, 34-35.

**Kopanic, R. J., Jr., B. W. Sheldon, and C. G. Wright. 1994.** Cockroaches as vectors of Salmonella: laboratory and field trials. J. Food Prot. 57: 125-133.

**Mizukubo, T. 1981.** A revision of the genus *Blattella* (Blattaria: Blattellidae) of Japan. I. Terminology of the male genitalia and description of a new species from Okinawa Island. Esakia 17: 149-159

**Pfannenstiel, R. S., W. Booth, E. L. Vargo, and C. Schal. 2008.** *Blattella asahinai* (Dictyoptera: Blattellidae): A new predator of lepidopteran eggs in South Texas soybean. Ann. Entomol. Soc. Am. 101: 763-768.

**Reierson, D. A., and M. K. Rust. 1984.** Insecticidal baits and repellency in relation to control of the German cockroach, *Blattella germanica* (L.). Pest Manage. 3: 26-32.

**Roth, L. M. 1986.** *Blattella asahinai* introduced into Florida (Blattaria: Blattellidae). Psyche 93: 371-374.

**Roth, L. M., and E. R. Willis. 1957.** The medical and veterinary importance of cockroaches. Smithsonian Institution, Washington, DC.

**Roth, L. M., and E. R. Willis. 1960.** The biotic associations of cockroaches. Smithsonian Institution, Washington, DC.

**SAS Institute. 2011.** SAS 9.1 Statistical analysis software. SAS Institute, Cary, NC.

**Schal, C., and R. L. Hamilton. 1990.** Integrated suppression of synanthropic cockroaches. Annu. Rev. Entomol. 35: 521-551.

**Snoddy, E. T. 2007.** Distribution and population dynamics of the Asian cockroach (*Blattella asahinai* Mizukubo) in Southern Alabama and Georgia. Master of Science Thesis, Auburn University.

**Snoddy, E. T., and A. G. Appel. 2008.** Distribution of *Blattella asahinai* (Dictyoptera: Blattellidae) in Southern Alabama and Georgia. *Ann. Entomol. Soc. Am.* 101: 397-401.

**Systat Software, Inc. 2011.** SigmaPlot for Windows, version 12.2. Systat Software, Inc., San Jose, CA.

**Tatfeng, Y. M., M. U. Usuanlele, A. Orukpe, A. K. Digban, M. Okodua, F. Oviasogi, and A. A. Turay. 2005.** Mechanical transmission of pathogenic organisms: the role of cockroaches. *J. Vector Borne Diseases* 42: 129-134.

**Throne, J. E., D. K. Weaver, V. Chew, and J. E. Baker. 1995.** Probit analysis of correlated data: multiple observations over time at one concentration. *J. Econ. Entomol.* 88: 1510-1512.

**Table 1. Granular bait insecticides used in the evaluation of the Asian cockroach toxicity experiments.**

Treatment	Compound	% AI <sup>a</sup>	Manufacturer	City, State	EPA Reg. No. <sup>b</sup>
Amdro®	hydramethylnon	0.730%	BASF	St. Louis, MO	241-322
Grant's Kills Ants	arsenic trioxide	0.460%	Grant Laboratories	San Leandro, CA	1663-1
Intice	orthoboric acid	5.00%	Rockwell Labs	N. Kansas City, MO	73079-2
MaxForce	imidacloprid	0.50%	Bayer	Kansas City, MO.	432-1375
Mint Oil Granules	mint oil	2.00%	Spectrum Group	St. Louis, MO	67425-121
Mother Earth	boric acid	5.00%	BASF	St. Louis, MO	499-515
Niban	orthoboric acid	5.00%	Nisus Corp.	Rockford, TN	73071-1
OverNOut	fipronil	0.0103%	Garden Tech	Lexington, KY	7969-212-71004
Safer Ant Bait	spinosad	0.0150%	Woodstream Corp.	Lititz, PA	62719-291

<sup>a</sup> %AI = percentage of active ingredient.

<sup>b</sup> EPA Reg. No. = Environmental Protection Agency registration number.



**Table 2. Toxicity of granular insecticides with and without competitive food to adult male Asian cockroaches in continuous exposure experiments.**

Treatment	Food <sup>a</sup>	n	Slope $\pm$ SE	LT <sub>50</sub> (95% CI)	$\chi^2$	P
Amdro	No	6	2.97 $\pm$ 0.37	2.18 (1.69-2.63)	64.60	<0.0001
	Yes	6	3.98 $\pm$ 0.32	4.61 (4.19-5.04)	147.56	<0.0001
Dog Chow	No	6	0.59 $\pm$ 0.23	1175 (107-3.24 <sup>11</sup> )	6.38	0.0115
Grant's Ant Killer	No	6	1.7 $\pm$ 0.17	8.51 (7.36-10.16)	99.05	<0.0001
	Yes	6	0.68 $\pm$ 0.21	33.90 (14.91-767)	10.39	0.0013
Intice	No	6	4.13 $\pm$ 0.38	3.58 (3.19-3.96)	116.67	<0.0001
	Yes	6	1.58 $\pm$ 0.23	7.55 (6.11-9.89)	46.70	<0.0001
MaxForce	No	6	1.98 $\pm$ 0.19	1.07 (0.78-1.35)	99.70	<0.0001
	Yes	6	2.14 $\pm$ 0.27	7.60 (6.48-9.19)	62.76	<0.0001
Mint Oil	No	6	2.45 $\pm$ 0.27	8.01 (6.99-9.44)	80.02	<0.0001
Granules	Yes	6	0.81 $\pm$ 0.25	452 (86-3.43x10 <sup>5</sup> )	10.46	0.0011
	No	6	2.57 $\pm$ 0.25	3.03 (2.54-3.51)	102.37	<0.0001
Mother Earth 5%	Yes	6	2.19 $\pm$ 0.27	5.42 (4.57-6.42)	64.40	<0.0001
	No	6	3.06 $\pm$ 0.28	3.21 (2.78-3.63)	117.69	<0.0001
Niban 5% BA	Yes	6	2.95 $\pm$ 0.24	5.20 (4.70-5.74)	145.60	<0.0001
	No	6	1.35 $\pm$ 0.21	1.56 (0.91-2.18)	41.46	<0.0001
OverNOut	Yes	6	3.75 $\pm$ 0.41	1.37 (1.13-1.59)	81.73	<0.0001
	No	6	0.73 $\pm$ 0.16	63.21 (28.9-400.77)	21.65	<0.0001
Safer Ant Bait	No	6	0.73 $\pm$ 0.16	63.21 (28.9-400.77)	21.65	<0.0001

	Yes	6	0.91 ± 0.26	209.76 (57-23323)	11.70	0.0006
Starve	No	6	4.68 ± 0.59	7.25 (6.49-8.14)	61.86	<0.0001
	Yes	6	4.68 ± 0.36	2.92 (2.67-3.61)	167.61	<0.0001

---

<sup>a</sup> Food is defined as no = no competitive food source, yes = competitive food source (Dog Chow).

**Table 3. Mean ( $\pm$  SE) consumption of granular baits with and without competitive food to adult male Asian cockroaches in continuous exposure experiments.**

Treatment	Food <sup>a</sup>	n	% mass loss in first 48 h	Consumption (g) in first 48 h
Amdro	No	6	1.00 $\pm$ 0.00	0.0214 $\pm$ 0.0053
	Yes	6	1.00 $\pm$ 0.00	0.0057 $\pm$ 0.0283
Dog Chow	No	6	0.00 $\pm$ 1.00	0.0265 $\pm$ 0.0043
	Yes	6	0.00 $\pm$ 1.00	0.0265 $\pm$ 0.0043
Grant's Ant Killer	No	6	2.00 $\pm$ 3.10	0.0839 $\pm$ 0.0478
	Yes	6	2.00 $\pm$ 3.10	0.0629 $\pm$ 0.0359
Intice 5% BA	No	6	1.00 $\pm$ 0.00	0.0513 $\pm$ 0.0013
	Yes	6	1.00 $\pm$ 0.00	0.0385 $\pm$ 0.0009
MaxForce	No	6	2.00 $\pm$ 0.00	0.0393 $\pm$ 0.0004
	Yes	6	2.00 $\pm$ 0.00	0.0275 $\pm$ 0.0003
Mint Oil Granules	No	6	2.00 $\pm$ 0.00	0.0345 $\pm$ 0.0003
	Yes	6	2.00 $\pm$ 0.00	0.0069 $\pm$ 0.0001
Mother Earth 5%	No	6	0.00 $\pm$ 0.00	0.0555 $\pm$ 0.0031
	Yes	6	0.00 $\pm$ 0.00	0.0416 $\pm$ 0.0009
Niban 5% BA	No	6	1.00 $\pm$ 0.00	0.0524 $\pm$ 0.0015
	Yes	6	1.00 $\pm$ 0.00	0.0393 $\pm$ 0.0011
OverNOut	No	6	1.00 $\pm$ 0.00	0.0224 $\pm$ 0.0002
	Yes	6	1.00 $\pm$ 0.00	0.0220 $\pm$ 0.0002
Safer Ant Bait	No	6	2.00 $\pm$ 0.00	0.0348 $\pm$ 0.0006

Yes 6 2.00 ± 0.00 0.0069 ± 0.0001

---

<sup>a</sup>Food is defined as no = no competitive food source, yes = competitive food source (Dog Chow).

## Chapter 4

### Field and Laboratory Efficacy of Three Insecticides Against the Asian Cockroach (*Blattella asahinai*, Mizukubo) in an Urban Environment

#### Introduction

The Asian cockroach, *Blattella asahinai* Mizukubo, is an increasingly important peridomestic pest in the southeastern United States (Hu et al. 2005, Snoddy and Appel 2008, Appel et al. 2009). This species, from Okinawa, Japan was first described in 1981 (Mizukubo 1981), and introduced into Florida in 1986 (Roth 1986). At that time it was limited to three adjacent counties around Tampa Florida (Brenner et al. 1986, Koehler and Patterson 1987) but as of 2007, all 67 counties in Florida have established populations (P.G. Koehler, personal communication). The Asian cockroach was identified in Dothan, Alabama in 2003 (Hu et al. 2005) and has spread throughout that city (Appel et al. 2009). Currently Asian cockroaches are distributed in seven counties in Alabama and eight counties in Georgia (Snoddy and Appel 2008).

Brenner et al. (1988) examined behavior, and distribution of the Asian cockroach in a microhabitat, and found that it had preferences for leaf litter and shady areas. In laboratory studies, Snoddy and Appel (submitted) determined that Asian cockroaches prefer warmer and more humid mulches such as artificial rubber. In citrus groves in Florida several studies evaluated if it was a pest on citrus and thus could be controlled (Brenner et al. 1988, Wadleigh et al. 1989, Persad et al. 2004, Richman 2005). This species was reported in south Texas soybean fields in 2008 feeding on Lepidoptera eggs

(Pfannenstiel et al. 2008). There have been no studies outside of Florida (Koehler 1999) and no recent studies on insecticide control of the Asian cockroach in urban environments, nor IPM programs established for the home owner.

In south Alabama, populations of the Asian cockroach begin to increase in late May and reach their zenith in late August; populations sharply decline with the onset of cool fall weather (Snoddy 2007). Surviving cockroaches burrow into leaf litter and top soil during dry weather or extreme temperatures (Snoddy 2007). The Asian cockroach is a peridomestic pest because it lives outdoors and enters the home where it becomes a nuisance to homeowners. The Asian cockroach lives outdoors so it is in contact with animal feces and several pathogens. Peridomestic cockroaches live outdoors and can be an economic pest associated with the food industry and for homeowners. Cockroaches that live outdoors can come into contact with pathogens, which they can mechanically vector or transmit to the inside of homes or food establishments. Peridomestic cockroaches can vector pathogens such as *Salmonella spp.* by physically contaminating food or food preparation surfaces (Kopanic et al. 1994, Tاتفeng et. al. 2005). A cockroach infestation usually indicates poor sanitation practices. Infestations in homes do not necessarily imply poor housekeeping practices because peridomestic cockroaches can build up large populations outdoors, particularly large species such as the smokybrown cockroach (Appel and Smith 1996) and the smaller Asian cockroach, and move inside as they forage for food. Foodstuffs can be contaminated inside a house with cockroach feces, body parts, and pathogens (Tاتفeng et. al. 2005). In addition, humans can develop allergies from cockroaches, their feces, and body parts when populations increase inside

the home (Ebeling, 1978). Most of these allergies are asthmatic in nature and, in some cases, can be life threatening.

Large outdoor Asian cockroach populations around the home can be invasive and cause homeowners to treat indoors. Homeowners and pest control operators who are not familiar with the difference between the Asian cockroach and the closely related German cockroach, *B. germanica* (L.), may treat inside the home exposing residents to ineffective and unnecessary residues of pesticides. The conventional practice for peridomestic insect control is to treat a perimeter around the house (“zone of death”) with a broad-spectrum residual insecticide (Koehler 1999, Appel and Smith 2002). Since the Asian cockroach is a strong flyer and can fly more than 120 feet, it is unlikely that a perimeter treatment would be effective. Re-infestations are likely since it is such a stronger flyer. Perimeter sprays have numerous draw backs including rapid degradation of the insecticide, exposure of residues to animals and the environment, and non-discriminatory elimination of numerous beneficial arthropods (Appel and Smith 2002). The Environmental Protection Agency (EPA) has withdrawn registrations of many commonly used insecticides such as chlorpyrifos and diazinon. Two common insecticides now available for homeowner treatment of outdoor pests are  $\beta$ -cyfluthrin liquid and fipronil granules, both of which show low mammalian toxicity (Yu 2008) and long residual control (Yu 2008). Koehler (1999) reported that in Florida the Asian cockroach is susceptible to most insecticides, which is in stark contrast to the closely related German cockroach that has shown resistance to numerous insecticides (Ebeling 1978, Cochran 1982, 1984).

The objective of this study was to select several candidate insecticides using laboratory studies and then evaluate the efficacy of several insecticides against the Asian

cockroach in an outside urban environment. An IPM program using selected effective insecticides as one component, could manage Asian cockroaches around the home while reducing the exposure of pesticides to humans, animals, and the environment.

## **Materials and Methods**

### **Laboratory Insecticide Applications**

**Insects.** The Asian cockroaches used in this study were originally collected in Dothan (Houston County), Alabama (31°15'16.24"N, 85°24'52.56"W). Colonies were maintained in 3.8 L glass jars with water oak, *Quercus nigra* L., leaves and 140 cm<sup>2</sup> cardboard harborages at 25 ± 2°C and 40-55% RH, exposed to a photoperiod of 12:12 (L:D) h, and supplied water and dry dog chow (Purina Dog Chow, Ralston Purina, St. Louis, MO.) ad libitum. Cockroaches were briefly anesthetized with CO<sub>2</sub> to facilitate handling. We used adult male cockroaches for the laboratory experiments because of their uniform body size and mass relative to other stages.

**Insecticides.** Three insecticides were tested in the laboratory and field experiments: β-cyfluthrin, 2.5% EC, (Bayer<sup>®</sup>, EPA Reg # 72155-58), fipronil 0.0103 % granules, GardenTech<sup>®</sup> Over NOut<sup>®</sup> (GardenTech<sup>®</sup>, Lexington KY, EPA Reg # 7969-212-71004), and an organic essential oil formulation, 30% Cinnamon and 10% Thyme oil EC, TC-291 Formula Code 231-050, was supplied by BASF<sup>®</sup> (Whitmire Micro-Gen). The TC-291 concentrate was diluted in water to 31.25 ml per liter of water (4 oz/gallon) for a finished solution. The β-cyfluthrin EC was applied at a rate of 7.81 ml/L (1 oz/gallon) of water for a finished spray solution. Fipronil granules were applied at a rate of 9.76 g / m<sup>2</sup> (0.90 g / ft<sup>2</sup>).



**Continuous Exposure Tests.** Two ml  $\beta$ -cyfluthrin or TC-291 was pipetted onto an (15 x 30.5 x 0.5 cm) aluminum foil-covered glass sheet. Fipronil granules (0.45 g) were applied evenly onto (15 x 30.5 x 0.5 cm) aluminum foil-covered sheets. Liquids were pipetted onto the inserts and spread evenly with a glass microscope slide every 5 min until completely dried under a laboratory fume hood. Total drying time did not exceed 1 h. Three 9 cm diameter Pyrex Petri dishes with the insides coated with a light layer of mineral oil to confine the insects to the residue were placed open side down onto a the foil covered sheet. Six cockroaches were introduced under each Petri dish and allowed to move freely under each dish. Mortality was recorded every 10 min for the  $\beta$ -cyfluthrin treated, and every 20 min for the TC-291 and fipronil treatments for the first 4 h and then every 2 to 24 h. After 24 h, data were recorded every 8 h until 48 h, at which time the test was terminated.

**Ebeling Choice Box Tests.** Cockroach repellency and mortality were determined in Ebeling choice boxes (Ebeling et al. 1966) as described by Appel (1990, 1992). Food and water were placed in the lighted compartment of the choice box. The  $\beta$ -cyfluthrin (2 ml of stock solution) and TC-291 (2 ml of stock solution) was pipetted onto an aluminum foil-covered insert (15 x 30.5 x 0.5 cm) that fit snugly into the floor of the dark compartment. Fipronil granules (0.45 g) were applied evenly onto an aluminum foil-covered insert. Control boxes were also fitted with aluminum foil-covered inserts, but were treated with 2 ml of distilled water. Both the  $\beta$ -cyfluthrin and TC-291 liquid stock solutions were pipetted onto the inserts and spread evenly with a glass microscope slide every 5 min until completely dried under a laboratory fume hood. Total drying time did not exceed 1 h. Ten male Asian cockroaches were introduced into the untreated light side

of the Ebeling Choice Box. Cockroaches were allowed to move freely between the dark (treated) and light (non-treated) compartments of the choice box.

Choice boxes were exposed to a photoperiod of 12:12 (L:D) h at 25-28°C. Banks of white florescent lights were 1.6 m above the choice boxes and produced a light intensity of 300-500 lux (INS Digital Lux Meter, Markson Scientific, Phoenix, AZ) in the untreated compartment. The number of live and dead cockroaches in each compartment at 3 to 4 h into the light photophase was recorded daily for 7 d. Repellency was defined as the mean percentage of live cockroaches present in the light compartment during the photophase. Six replicates were used for each treatment in a completely randomized design.

**Data Analysis.** Mortality ( $LT_{50}$ ) in the continuous exposure tests were analyzed by probit analysis for correlated data (Throne et al. 1995) because multiple observations were taken on the same individuals. Probit analysis was also used to estimate insecticide toxicity ( $LT_{50}$ ) in the Ebeling choice box test. Significant differences  $LT_{50}$  values were based on non-overlap of the 95% CI (SAS Institute 2011). Repeated-measures analysis of variance (ANOVA) was used for repellency of adult males (SAS Institute 2011). For each type of insecticide, change in repellency of adult males in Ebeling choice boxes was plotted over time, and analyzed using linear regression (Systat Software, Inc. 2011). Cockroach field population data were analyzed using SAS Institute software (SAS Institute 2011). A split-plot repeated measures ANOVA was used to determine differences between sites and among insecticide treatments (Proc Mixed, SAS Institute 2011). Differences were considered significant using the lsmeans procedure at  $P \leq 0.05$ .

## **Field Insecticide Applications**

**Insects.** Based on Asian cockroach populations and availability of large infected plots, two field sites were selected in Dothan, Alabama. One site was Landmark Park (31° 17' 21.24" N 85° 22' 11.93" W, elevation 89 m); the other site was the Camelot Apartment complex (31° 13' 45.81" N 85° 26' 23.94" W, elevation 89 m). Three blocks, each consisting of four 7.62 m x 3.05 m (23.24 m<sup>2</sup>) deep plots, were established at each of the two field sites. Treatments were assigned randomly within blocks.

**Sampling Technique.** Asian cockroach populations were sampled using the method described by Snoddy (2007). Briefly, the bottom of a standard white 5-gallon (~19 L) plastic paint bucket (Lowe's, Opelika, AL) bucket was removed and sides sharpened. The modified bucket was placed on the ground and quickly driven into the leaf litter. This procedure allowed adult Asian cockroaches to fly from the enclosed 507 cm<sup>2</sup> leaf litter to the sides of the bucket and to run on the inside walls where they could be counted. Nymphs would also run up the side of the bucket and could be easily counted. Driving the bucket into the leaf litter assured an accurate count in a confined space (507 cm<sup>2</sup>) with a minimum of escapees. Each plot was sampled five times and the counts were combined.

**Insecticide Treatments.** We tested the three insecticides described above. The TC-291 concentrate was diluted in water to 31.25 ml/ L (4 oz/gallon) and applied at a rate of 15.14 L (4 gallons) of finished spray per 23.24 m<sup>2</sup> (250 ft<sup>2</sup>).  $\beta$ -cyfluthrin EC was applied at a rate of 7.81 ml/L (1 oz per gallon) of water and 0.45 L / 23.24 m<sup>2</sup> (0.12 gallon / 250 ft<sup>2</sup>). Fipronil granules were applied with a hand-held spreader at a rate of 227 g / 23.24 m<sup>2</sup> (250 ft<sup>2</sup>). The spray tank was cleaned between treatments using All Clear<sup>®</sup> Spray Tank Decontaminator (Loveland Products, Greeley, CO.).

Liquid formulations were mixed in a County Line<sup>®</sup> Tractor Supply Co. 94.62 L (25 gl.) ATV mounted boom-less sprayer with a hand wand. The hand wand was equipped with an adjustable brass tip with 100 mesh screen (Hamilton Power Jet Wand, Model # 1900-01-018; W. L. Hamilton Co., Marshall, MI.) and was mounted on 25 foot of 3/8 ID AG 200 braded rubber hose. The 94.62 L (25 gl.) tank was a 12 v powered sprayer that had a 14.5 L/min (3.8 g/m) capacity pump with recirculation for agitation. A 12 v PowerFlo<sup>™</sup> diaphragm pump (Delavan Pump Inc., model # 5836-201C-BP) was used to power the sprayer. The sprayer was mounted on a 1996 Honda<sup>®</sup> ATV (model # TRX400FWT) and was hard wired into the electrical system for continuous electrical supply to the pump.

The 94.62 L (25 gallon) tank was half-filled with clean water (City of Auburn, AL. water), liquid insecticides were introduced into the tank with full agitation, and the tank was then filled to 94.62 L (25 gallon) capacity. Insecticides were agitated for 5 min before application. Insecticides were applied to the test plots using the hand held wand at the rate of 3.785 L (1 gallon) per minute @ 40 psi pressure. After application of insecticides the tank was washed once with clean water, and the lines were flushed with clear water. The tank was then half filled with clean water and All Clear<sup>®</sup> Spray Tank Decontaminator was added at the rate of 473.12 ml (16 oz.) / 94.62 L (25 gallon) of water under agitation, and the tank was filled to the 94.62 L (25 gallon) capacity and allowed to agitate for 5 min, all lines were flushed with the All Clear<sup>®</sup> Spray Tank Decontaminator mixture during the agitation process and then emptied. The tank was then washed with clean water and all lines were flushed with clean water.

The number of Asian cockroaches was sampled on 7 September 2010 (Day 0) and treatments were applied the same day. Cockroach populations were sampled again 1, 7, 21, and 30 d after treatment using the same technique as described above.

## RESULTS

**Continuous Exposure.** There was significant mortality of adult male Asian cockroaches in the  $\beta$ -cyfluthrin and fipronil treatments ( $P>0.05$ ); however, there was no significant mortality in the control and TC-291 treatments. The  $LT_{50}$  (95% CI) value for  $\beta$ -cyfluthrin was 0.014 (0.013-0.015) d; slope of  $8.83 \pm 0.68$ ;  $\chi^2 = 169.61$  and  $P < 0.0001$ . For fipronil the  $LT_{50}$  value was 0.45 (1.32-4.22) d; slope of  $2.43 \pm 0.96$ ;  $\chi^2 = 12.47$  and  $P=0.0001$ . For TC-291 the  $LT_{50}$  value was 11.14 (4.84-42.17) d; slope of  $0.72 \pm 0.09$ ;  $\chi^2 = 63.76$  and  $P < 0.0001$ .

**Choice Box Insecticide Toxicity.**  $LT_{50}$  values for adult male cockroaches confined in Ebeling choice boxes ranged from 0.64-175.54 d for  $\beta$ -cyfluthrin and the control, respectively (Table 1). There was a significant treatment and time effect at  $P < 0.05$ , however there was no significant treatment by time interaction.

**Choice Box Insecticide Repellency.** Mean repellency of adult male Asian cockroaches ranged from 20.62 to 59.99% for the control and  $\beta$ -cyfluthrin, respectively (Table 2). There was not a significance difference between the mean repellency of the control, TC-291, and fipronil (Table 2). There was a significance difference between the mean repellency of  $\beta$ -cyfluthrin when compared to the control and TC-291 but not fipronil (Table 2).

**Field Insecticide Applications.** The mean number of Asian cockroaches sampled before treatment ranged between 4.8 cockroaches in the TC-291 plot to 6.5 cockroaches for the control plot (Table 3). However these numbers were not significantly different indicating approximately equivalent cockroach populations in all of the plots. Treatments were easily and efficiently applied. The mean number of Asian cockroaches sampled in all of the insecticide treatments declined 46-72% in 1 day; the number of cockroaches in the control, however, increased 69% probably due to the flushing activity of the TC-291 treatment (Fig. 1, Tables 1 and 2). At days 7 through 30, the number of Asian cockroaches in the control was similar to the pretreatment numbers (Table 3). In the insecticide treatments, the TC-291 reduced cockroach numbers ~69% and the granular fipronil and liquid  $\beta$ -cyfluthrin EC reduced cockroach numbers 100% (Fig. 1). There was no change in percentage reduction between days 7 and 21 for the insecticide treatments; there were still cockroaches present in the TC-291 treatment. Thirty days after treatment, cockroach numbers had increased to pretreatment values in the TC-291 treatment (and the control), but no cockroaches were detected in the fipronil granule or  $\beta$ -cyfluthrin EC spray treatments (Fig. 1. and Table 3). Split plot in-time analysis revealed significant ( $P < 0.05$ ) treatment, site, and treatment by site interactions. Adjusting for these fixed effects and combining all dates, the insecticide treatments resulted in significantly lower cockroach numbers than the control ( $P < 0.0001$ , Fig. 1).

## **DISCUSSION**

As it was first discovered in southern Alabama, the Asian cockroach has been a peridomestic pest around homes (Hu et al. 2005, Snoddy and Appel 2008). Populations

generally begin to increase in May and reach their zenith in early September; during this time, many of these cockroaches find their way into the home and become pests (Snoddy 2007). Brenner et al. (1988) found that the Asian cockroach preferred moist shady leaf mulch around homes. Snoddy and Appel (submitted for publication, Chapter 5) found that even inorganic rubber mulch is attractive to this species. Most homes in southern Alabama have some type of mulch landscaping around them, which could enhance populations of the Asian cockroach. Pest control operators not familiar with the Asian cockroach may misidentify it as a German cockroach and treat indoors unnecessarily exposing home owners to unnecessary and ineffective pesticide residues. The registration of numerous outdoor insecticides has been recently rescinded by the EPA. These compounds tended to have high mammalian toxicity and were not considered to be environmentally friendly. Newer environmentally friendly compounds with lower mammalian toxicity such as  $\beta$ -cyfluthrin and fipronil have become the most commonly marketed outdoor insecticides for the homeowner (Snoddy 2011 unpublished data).

There were no differences between the fipronil granular treatment and the liquid  $\beta$ -cyfluthrin EC spray treatments, and both the granular and spray treatments had significantly fewer cockroaches than the TC-291 treatment (Table 3). This is consistent with observations in the laboratory Ebeling choice box toxicity and continuous exposure experiments (Table 1). The increase in populations of the control was most likely due to the flushing action of the TC-291 on adults and nymphs. When we applied the TC-291 essential oil concentrate to the plots we observed the flushing action at both locations. This observation could indicate repellency of the TC-291 compound, although we did not observe repellency in the laboratory Ebeling choice box experiments when compared to

the control (Fig. 1). The differences between these two observations could be in the amount of TC-291 solution used. Although both in the laboratory experiments and the field applications, the exact same amount of active ingredient was used for our application solution. The amount of solution in the field was based on labeled rates and created a “past run off” result on the leaf litter whereas in the laboratory the TC-291 was allowed to dry before the adult male cockroaches were introduced.

The liquid  $\beta$ -cyfluthrin EC yielded the fastest reduction and knockdown of populations among all the insecticide treatments (Table 3 and Fig. 1), which was also consistent with observations in the laboratory Ebeling choice box toxicity and continuous exposure experiments (Table 1). S.F. Abd-Elghafar et. al. (1990) also found  $\beta$ -cyfluthrin EC to be the most toxic out of 10 different insecticides tested against the closely related and similar size German cockroach. The fipronil granules took just a few days longer to knockdown populations as is typical with granular insecticide applications (Table 3 and Fig. 1). There was a significant difference in the repellency of the fipronil and  $\beta$ -cyfluthrin treatments versus the control and TC-291 treatments in the laboratory Ebeling choice box experiments. This can be attributed to how fast the  $\beta$ -cyfluthrin treatment killed (100% mortality in <48 h). Efficacy of an insecticide not only includes how lethal it is as compound to insects but also on its repellency. There was greater repellency with fipronil and  $\beta$ -cyfluthrin treatments in laboratory experiments (Fig. 1), but this did not diminish the efficacy of the products in the field.

The TC-291 essential oil concentrate formulation reduced Asian cockroach numbers in this small plot field trial. Population reductions never exceeded ~69% and populations rebounded to pretreatment numbers by 30 d after treatment. The repellent



nature of this essential oil formulation and a shorter residual probably accounted for the results. TC-291 may be a useful formulation as part of a pest management system, but cannot be recommended as a stand-alone formulation for perimeter application against a peridomestic pest such as the Asian cockroach. This is consistent with the laboratory Ebeling box toxicity and continuous exposure experiments. In addition to the lack of control of TC-291 as an organic essential oil treatment, the product has an obvious odor and most likely would not be well accepted or tolerated by the homeowner. Both fipronil granules and liquid  $\beta$ -cyfluthrin EC spray were quite toxic to Asian cockroaches and resulted in 100% reductions at days 7, 21, and 30 after treatment. Clearly both formulations had superior residual and were more toxic than TC-291. Both fipronil granules and liquid  $\beta$ -cyfluthrin EC spray have a low mammalian toxicity and provide excellent residual activity to control the Asian cockroach. As both fipronil granules and liquid  $\beta$ -cyfluthrin EC spray were highly toxic to the Asian cockroach, these products should be considered in an IPM program when trying to control populations of Asian cockroaches around the home. Selection to use a liquid or granular product would depend upon the homeowner; granular products are the easiest to apply but tend to be slower in control, whereas liquid products take more effort but yield the fastest control results.

## References

- Abd-Elghafar, S. F., A. G. Appel, and T. P. Mack. 1990.** Toxicity of several insecticide formulations against adult German cockroaches (Dictyoptera: Blattellidae). *J. Econ. Entomol.* 83: 2290-2294.
- Appel, A. G. 1990.** Laboratory and field performance of consumer bait formulations for German cockroach (Dictyoptera: Blattellidae) control. *J. Econ. Entomol.* 83: 153-159.
- Appel, A. G. 1992.** Performance of gel and paste bait products for for German cockroach (Dictyoptera: Blattellidae) control: laboratory and field studies. *J. Econ. Entomol.* 85: 1176-1183.
- Appel, A. G., M. J. Eva, and E. T. Snoddy. 2009.** Distribution of the Asian cockroach, *Blattella ashinai* (Dictyoptera: Blattidae) in Dothan, Alabama. *J. of Alabama Academy of Science* Vol. 80, No. 1: 1-7.
- Appel, A. G., and L. M. Smith. 1996.** Harborage preferences of American and smokybrown cockroaches (Dictyoptera: Blattidae) for common landscape materials. *Env. Entomol.* 25: 817-824.
- Appel, A. G., and L. M. Smith. 2002.** Biology and management of the smokybrown cockroach. *Annu. Rev. Entomol.* 47: 33-55.
- Brenner, R. J., P. G. Koehler, and R. S. Patterson. 1986.** A profile of America's newest import, the Asian Cockroach. U.S. Department of Agriculture, Agricultural Research Service. [Washington, D.C.: The Service] Nov/Dec p. 17-19.
- Brenner, R. J., P. G. Koehler, and R. S. Patterson. 1988.** Ecology, behavior and distribution of *Blattella asahinai* (Orthoptera: Blattellidae) in central Florida, USA. *Ann. Entomol. Soc. Am.* 81: 432-436.
- Cochran, D. G. 1982.** German cockroach resistance: new mode of action could stalemate resistance. *Pest Control* 50: 16, 18, 20.
- Cochran, D. G. 1984.** Insecticide resistance in cockroaches: is it at a crossroads? *Pest Manage.* 3: 26-31.
- Ebeling, W. 1978.** *Urban Entomology.* University of California.

- Ebeling, W., R. E. Wagner, and D. A. Reiersen. 1966.** Influence of repellency on the blatticides. I. learned modification of behavior of the German cockroach. *J. Econ. Entomol.* 59: 1374-1388.
- Hu, X. P., A. G. Appel, and R. Vester. 2005.** Asian cockroach “invades” Alabama. *Pest Control.* JAN 41-42.
- Koehler, P.G. 1999.** Asian Cockroach. Entomology and Nematology Department, Florida Cooperative Extension Service, Institute of Food and Agricultural Sciences, University of Florida. Document ENY-202.
- Koehler, P. G., and R. S. Patterson. 1987.** The Asian roach invasion. *Natural History.* 96: 11, 28, 30, 32, 34-35.
- Kopanic, R. J., Jr., B. W. Sheldon, and C. G. Wright. 1994.** Cockroaches as vectors of Salmonella: laboratory and field trials. *J. Food Prot.* 57: 125-133.
- Mizukubo, T. 1981.** A revision of the genus *Blattella* (Blattaria: Blattellidae) of Japan. I. Terminology of the male genitalia and description of a new species from Okinawa Island. *Esakia* 17: 149-159.
- Persad, A. B., and M. A. Hoy. 2004.** Predation by *Solenopsis invicta* and *Blattella asahinai* on *Toxoptera citricida* parasitized by *Lysiphlebus testaceipes* and *Lipolexis oregmae* on citrus in Florida. *Biological Control* 30: 531-537.
- Pfannenstiel, R. S., W. Booth, E. L. Vargo, and C. Schal. 2008.** *Blattella asahinai* (Dictyoptera: Blattellidae): A new predator of lepidopteran eggs in South Texas soybean. *Ann. Entomol. Soc. Am.* 101: 763-768.
- Richman, D. L. 2005.** Asian Cockroach, *Blattella asahinai* Mizukubo (Insecta: Blattodea: Blattellidae). Entomology and Nematology Department, Florida Cooperative Extension Service, Institute of Food and Agricultural Sciences, University of Florida. Document ENY-277.
- Roth, L. M. 1986.** *Blattella asahinai* introduced into Florida (Blattaria: Blattellidae). *Psyche* 93: 371-374.
- SAS Institute. 2011.** SAS 9.1 Statistical analysis software. SAS Institute, Cary, NC.
- Snoddy, E. T. 2007.** Distribution and population dynamics of the Asian cockroach (*Blattella asahinai* Mizukubo) in Southern Alabama and Georgia. Master of Science Thesis, Auburn University.
- Snoddy, E. T., and A. G. Appel. 2008.** Distribution of *Blattella asahinai* (Dictyoptera: Blattellidae) in Southern Alabama and Georgia. *Ann. Entomol. Soc. Am.* 101: 397-401.

**Snoddy, E. T., X. P. Hu and A. G. Appel. 2008.** Asian Cockroach: New pest in urban environments. Alabama Cooperative Extension System, Auburn University. Document ANR-1322.

**Systat Software, Inc. 2011.** SigmaPlot for Windows, version 12.2. Systat Software, Inc., San Jose, CA.

**Tatfeng, Y. M., M. U. Usuanlele, A. Orukpe, A. K. Digban, M. Okodua, F. Oviasogi, and A. A. Turay. 2005.** Mechanical transmission of pathogenic organisms: the role of cockroaches. *J. Vector Borne Diseases* 42: 129-134.

**Throne, J. E., D. K. Weaver, V. Chew, and J. E. Baker. 1995.** Probit analysis of correlated data: multiple observations over time at one concentration. *J. Econ. Entomol.* 88: 1510-1512.

**Wadleigh, R. W., P. G. Koehler, and R. S. Patterson. 1989.** Comparative susceptibility of North American *Blattella* (Orthoptera: Blattellidae) species to insecticides. *J. Econ. Entomol.* 82: 1130-1133.

**Yu, S. J. 2008.** The toxicology and biochemistry of insecticides. CRC Press, FL.

**Table 1. Toxicity of insecticides to adult male Asian cockroaches exposed in either continuous or Ebeling choice box experiments.**

Exposure	Treatment	<i>n</i>	Slope ± SE	LT <sub>50</sub> d (95%CI)	$\chi^2$	<i>P</i>
Continuous	Control	36	-	-	-	-
	Cyfluthrin (0.75%)	36	8.83 ± 0.68	0.014 (0.013-0.015)	169.61	<0.0001
	Fipronil (0.0103%)	36	2.43 ± 0.96	0.45 (1.32-4.22)	12.47	0.0001
	BASF TC-291	36	0.72 ± 0.09	11.14 (4.84-42.17)	63.76	<0.0001
Choice box	Control	36	0.89 ± 0.40	175.54 (28.79-1.2x10 <sup>17</sup> )	4.89	0.0271
	Cyfluthrin (0.75%)	36	4.05 ± 0.96	0.64 (0.35-0.83)	17.77	<0.0001
	Fipronil (0.0103%)	36	4.74 ± 0.54	1.98 (1.71-2.24)	76.47	<0.0001
	BASF TC-291	36	1.18 ± 0.39	59.64 (19.46-9630)	9.21	0.0024

**Table 2. Repellency of male adult Asian cockroaches to insecticides in Ebeling choice boxes.**

Treatment	<i>n</i>	Estimate ± SE <sup>a</sup>	DF	<i>t</i>	<i>P</i>
Control	36	20.62 ± 6.81 b	14	3.03	0.0091
Cyfluthrin (0.75%)	36	59.99 ± 15.98 a	14	3.75	0.0021
Fipronil (0.0103%)	36	34.50 ± 7.54 ab	14	4.57	0.0004
BASF TC-291	36	20.69 ± 6.88 b	14	3.00	0.0095

<sup>a</sup> means followed by different letter are significantly different at  $P < 0.05$  using the lsmeans procedure (SAS Institute 2011)

**Table 3. Mean ( $\pm$  SE) number Asian cockroaches sampled at Dothan, AL field sites before and after insecticide treatments.**

Treatment	n	Day				
		0	1	7	21	30
Control	6	6.5 $\pm$ 2.4	11.0 $\pm$ 3.0	7.3 $\pm$ 1.1	5.5 $\pm$ 1.7	7.0 $\pm$ 1.4
TC291	6	4.8 $\pm$ 0.9	2.5 $\pm$ 1.0	1.5 $\pm$ 1.0	1.7 $\pm$ 1.3	4.7 $\pm$ 1.1
Fipronil	6	5.0 $\pm$ 1.5	2.7 $\pm$ 1.0	0	0	0
$\beta$ -Cyfluthrin	6	6.0 $\pm$ 1.1	1.7 $\pm$ 1.3	0	0	0

n = number of replications, Day 0 = pretreatment mean

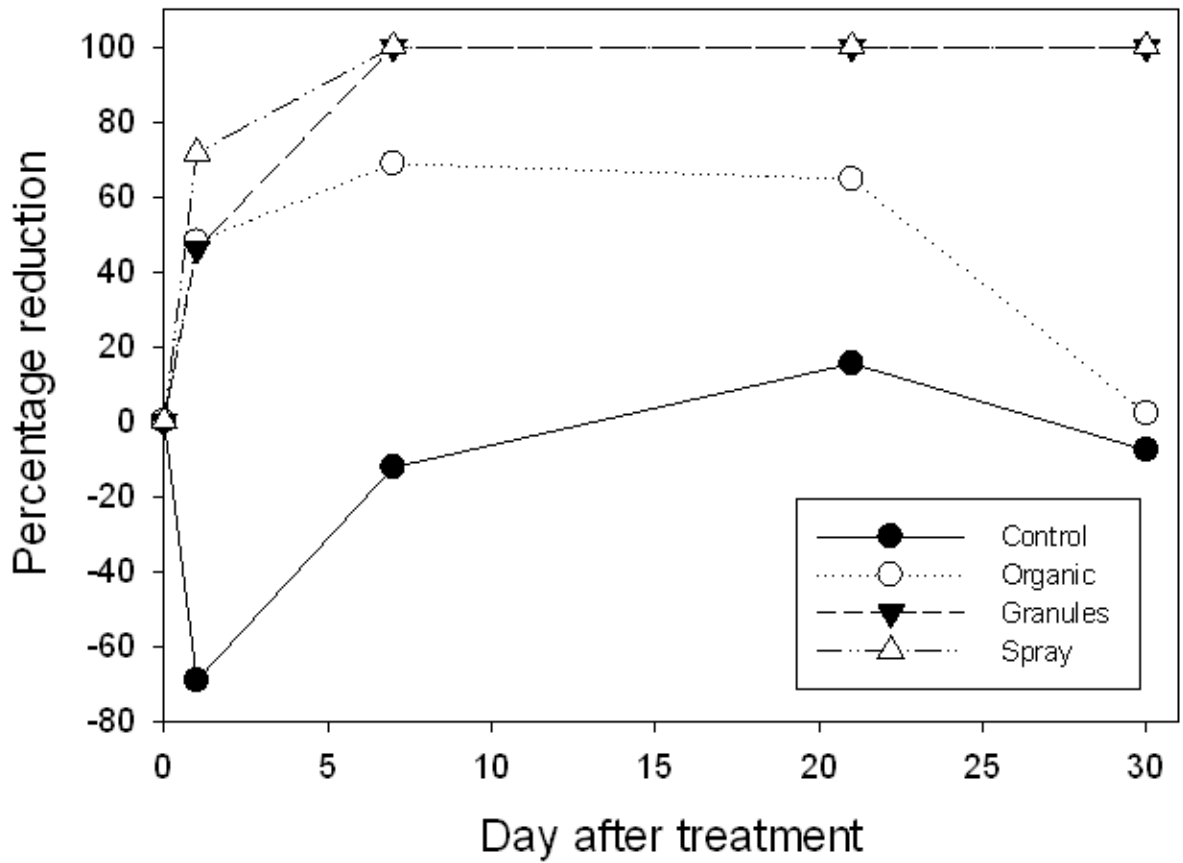

**Figure 1. Mean percentage reduction of Asian cockroach numbers following treatments. Note, negative percentage reduction indicates an increase in cockroach numbers.**



## Chapter 5

### **Mulch Preferences of the Asian Cockroach, *Blattella asahinai* Mizukubo (Dictyoptera: Blattellidae)**

#### **Introduction**

The Asian cockroach, *Blattella asahinai* Mizukubo, is a peridomestic pest species from Okinawa, Japan first described in 1981 (Mizukubo 1981), and introduced into Florida in 1986 (Roth 1986). The first account of the Asian cockroach was limited to three adjacent counties around Tampa Florida (Brenner et al. 1986; Koehler and Patterson 1987). By 2007, all 67 counties in Florida have established populations (Snoddy and Appel 2008). In early 2003, the Asian cockroach was identified for the first time outside of Florida in Dothan, Alabama (Hu et al. 2005). Currently Asian cockroaches are distributed in seven counties in Alabama reaching as far North as Barbour County; and eight counties in Georgia reaching as far North as Houston County (Snoddy and Appel 2008). In 2008, the cockroach was reported in south Texas soybean fields feeding on Lepidoptera eggs (Pfannenstiel et al. 2008).

Several basic biological studies have been conducted in the laboratory, but few field studies have been attempted (Ross and Mullins 1988, Brenner et al. 1988, Atkinson et al. 1999, Lawless 1999). The Asian cockroach is a small (< 25 mm) species that is similar to the German cockroach, *Blattella germanica* (L.). The German cockroach is a domestic pest that only lives indoors, does not fly, and is negatively phototaxic (Ebeling 1978, Rust et al. 1995). In contrast, Asian cockroaches live outdoors as a peridomestic

pest, is a strong flyer, and positively phototactic (Brenner et. al. 1988, Snoddy and Appel 2008). The Asian cockroach is attracted to the lights of a building and often enters homes. It can therefore be confused with a German cockroach if proper identification is not made. Misidentification can lead to unnecessary indoor treatments that can expose humans and pets to unnecessary pesticide residues, but do not control the Asian cockroach.

In southeastern Alabama, populations of the Asian cockroach begin to increase in late May, reach their zenith in late August to early September, and then sharply decline with the onset of cool fall weather (Snoddy 2007). Brenner et al. (1988) examined behavior, and distribution of the Asian cockroach in a microhabitat, and found that it preferred leaf litter and shady areas. Since many houses have leaf litter-type mulch around the home as landscaping, the Asian cockroach has abundant harborage areas and can develop large populations. Large outdoor populations can become pest problems indoors when the cockroaches are attracted to the lights of the home or foraging for food. The Asian cockroach burrows into leaf litter and soil interfaces during adverse weather conditions (e.g., dry weather or cold temperatures) (Snoddy 2007). Since the Asian cockroach lives outdoors it is in contact with animal feces and several soil pathogens, and can mechanically vector pathogens such as *Salmonella spp.* by physically contaminating food or food preparation surfaces (Roth and Willis 1957, 1960, Kopanic et al. 1994, Tاتفeng et al. 2005). Cockroach feces and body parts can be allergenic to sensitive individuals (Ebeling 1978, Schal and Hamilton 1990). Some type of mulch is almost always used in landscaping, so the Asian cockroach is not limited to homes, but can also affect hotels, office buildings, and restaurants.

There is little information on the harborage preferences of peridomestic cockroaches including the Asian cockroach. Harborage preferences of cockroach species such as the American, *Periplaneta americana* (L.), and the smokybrown, *P. fuliginosa* (Serville) are mediated by the physical characteristics of the harborage and the presence of conspecifics (Appel and Smith 1996). American and smokybrown cockroach small (1-10 mm) nymphs prefer harborages with smaller interstitial spaces than that of larger nymphs (20-30mm) and adult conspecifics (Appel and Smith 1996).

The objective of this study was to evaluate the preferences of the Asian cockroach to typical mulch materials that are commonly found in southern Alabama where this cockroach is a peridomestic pest. With mulch preference, repellency, and toxicity data it may be possible to incorporate mulch selection into an Integrated Pest Management (IPM) program for the homeowners. An IPM program could manage Asian cockroach populations around homes and reduce insecticide use and exposure.

## **Materials and Methods**

**Insects.** The Asian cockroaches used in this study were collected in Dothan (Houston County), Alabama (31°15'16.24"N, 85°24'52.56"W). Adults and nymphs were collected by hand and transferred to a 7.6 L glass jar that contained a round 5 cm diameter 140 cm<sup>2</sup> cardboard harborage and transported back to Auburn University and maintained for the last 3 y in the laboratory. Colonies were maintained in 7.6 L glass jars with water oak, *Quercus nigra* L., leaves and 140 cm<sup>2</sup> cardboard harborages at 25 ± 2°C and 40-55% RH, exposed to a photoperiod of 12:12 (L:D) h, and supplied water and dry dog chow (Purina Dog Chow, Ralston Purina, St. Louis, MO) ad libitum. Cockroaches

were collected from jars and anesthetized with CO<sub>2</sub> to facilitate handling. For the large arena tests, 10 females, 10 males, 25 small nymphs (1-3 mm in length), 25 medium nymphs (4-7 mm) and 30 large nymphs (8-12 mm) were used. Cockroaches were placed in 500 ml cardboard cylinders and then transferred to the arenas. For the Ebeling Choice Box repellency tests we transferred ten adult males directly into the choice boxes. Adult males were used in the choice box tests because of their uniformity in body size, behavior, and physiology.

**Mulches.** Five common mulches were selected for evaluation: cypress mulch from *Taxodium* spp. (Garick Company, Cleveland Ohio 44125), *Q. nigra* leaf litter from (Auburn, Alabama), pine straw, *Pinus* spp. (Baled Pine Straw, Home Depot, Opelika Alabama), red rubber mulch (Vigor Branded, Distributed by Home Depot, Atlanta Georgia), and topsoil (Auburn, Alabama).

**Large Arena Tests.** Harborage preference was determined in (76.2 x 76.2 x 29.2 cm high) wooden boxes painted white and covered with tight fitting window screens. Five cm-wide foil tape (Shurtape Technologies LLC, Hickory NC 28601) was applied to the upper inside walls of each box and coated with mineral oil to deter escape. Mulch materials were placed in clear 5.7-L plastic shoe boxes (Sterilite Product # 1851, Sterilite Corporation, Townsend, MA 01469) to a depth of 5 cm. Preliminary tests indicated that all developmental stages of the Asian cockroach could readily climb the sides of the boxes. All mulches were sprayed daily with 6 ml of water from a 710 ml spray bottle (The Bottle Crew, Product Item # E-24, West Bloomfield MI 48322) that produced a fine mist of water to simulate morning dew. Plastic boxes containing the mulch treatments were positioned, in a random order, in a circle on the floor of the arena. In the center of

the arena I placed ~3 g of dry dog chow (Purina Dog Chow, Ralston Purina, St. Louis, MO.) in an aluminum foil weigh pan, and a 75 ml vial of water with a cotton wick inserted through the cap. Cardboard cylinders containing 100 Asian cockroaches (see above distribution of life stages) were placed on the arena floor and the top removed; the cardboard cylinders were removed 8 h later. Arenas were kept in a room at  $25 \pm 2^\circ\text{C}$ , 40-55% RH, and exposed to a photoperiod of 12:12 (L:D) h. Treatments were replicated six times in a complete randomized design. The mulch and cockroaches were not disturbed for 7 d, after which time mulch treatments were covered and removed. The boxes were removed during daylight hours when the cockroaches were in the mulches. Each box containing a mulch treatment was filled with  $\text{CO}_2$  (to anesthetize the cockroaches) and the number of each stage was recorded.

**Continuous Exposure Test.** Six adult males were confined in a 0.95 L glass jar with ~3 g of dog food, a 75 ml vial of water with a cotton wick inserted through the cap, and a  $140 \text{ cm}^2$  cardboard harborage (Appel 1992). Petroleum jelly was used to lightly coat the upper inside surface of the jar, and filter paper covers secured with metal bands prevented cockroach escape. Jars were treated with one of each mulch material to a depth of 5 cm. Jars containing experimental controls contained no mulches. All test mulches and controls were replicated six times in a completely randomized design. Jars were kept in a room at  $25 \pm 2^\circ\text{C}$ , 40-55% RH, and exposed to a photoperiod of 12:12 (L:D) h. The number of live and dead cockroaches in each jar was recorded daily 3-4 h into the photophase for 7 d.

**Choice Box Tests.** Cockroach repellency and mortality were determined in Ebeling choice boxes (Ebeling et al. 1966) as described by Appel (1990, 1992). Food and

water were placed in the lighted compartment of the choice box. A treatment consisting of one mulch material was placed uniformly to a depth of 5 cm deep over the entire floor of the dark compartment. Control boxes had no mulch material in the dark compartment. Treatments were allocated randomly to the choice boxes. Ten male Asian cockroaches were released into the untreated compartment of each choice box. Cockroaches were able to move freely between the dark (treated) and the light side (untreated) compartments through a 13 mm diameter hole in the partition separating the sides. Five mulch treatments were used and replicated six times in a completely randomized design.

The choice boxes were exposed to  $25 \pm 2^\circ\text{C}$ , 25-40% RH, and a photoperiod of 12:12 (L:D) h. Banks of white florescent lights were  $\sim 1.6$  m above the choice boxes and produced a light intensity in the untreated (light side) compartment of 300-350 lux (INS Digital Lux Meter, Markson, Phoenix AZ.) The number of live and dead cockroaches in each compartment was recorded at 3-4 h into the photophase daily for 7 d. Repellency was defined as the mean percentage of live cockroaches present in the light compartment during the photophase.

**Physical Measurements.** Temperature, relative humidity, and interstitial spaces were measured 15 times at randomized depths ( $>0$  to 5 cm) in each of the mulches. Light intensity was measured 15 times at the depth of 5 cm. Temperature was measured with a bead-type copper-iron thermocouple; relative humidity was measured with a capacitive probe; and light intensity was measured using a light sensor. Temperature and relative humidity sensors were connected to a microprocessor (Tri-Sense, Cole-Parmer, Niles, IL.) that instantaneously recorded the environmental characteristics. Interstitial spaces within each mulch material were measured to the nearest 1 mm with a plastic ruler.

**Data Analysis.** Mulch preferences were analyzed for each stage and for all stages combined using a Kruskal-Wallis analysis of variance (ANOVA) on ranks followed by a Tukey pairwise multiple comparison test (Systat Software, Inc. 2011). Mortality ( $LT_{50}$ ) in the continuous exposure tests were analyzed by probit analysis for correlated data (Throne et al. 1995) because multiple observations were taken on the same individuals. Probit analysis was also used to estimate mulch toxicity ( $LT_{50}$ ) in the Ebeling choice box test. Significant differences  $LT_{50}$  values were based on non-overlap of the 95% confidence intervals (CI). Repeated-measures analysis of variance (ANOVA) was used for repellency of adult males (SAS 2011). For each type of mulch, change in repellency of adult males in Ebeling choice boxes was plotted over time, and analyzed using linear regression (Systat Software, Inc. 2011). Differences in physical characteristics among mulches were determined using Kruskal-Wallis analysis of variance (ANOVA) on ranks followed by Tukey pairwise multiple comparison tests (Systat Software, Inc. 2011).

## RESULTS

**Large Arena Mulch Preference.** Adult male Asian cockroaches preferred oak leaf litter ( $54.33 \pm 6.30\%$ ) and pine straw ( $33.00 \pm 6.33\%$ ) over all other mulches (Table 1), whereas adult females preferred oak litter ( $34.00 \pm 3.89\%$ ) and rubber mulch ( $32.00 \pm 4.84\%$ ) (Table 1). Small ( $48.33 \pm 13.08\%$ ), medium ( $62.50 \pm 6.51\%$ ), and large ( $55.17 \pm 8.39\%$ ) nymphs preferred the rubber mulch compared with other mulches (Table 1). Nymphs in general preferred rubber mulch over the other mulches regardless of their size. When stages of the Asian cockroach were combined, rubber mulch ( $45.33 \pm 5.21\%$ ) and oak litter ( $29.17 \pm 2.41\%$ ) were preferred over all other mulches (Table 1).

**Continuous Exposure.** There was no significant mortality of adult male Asian cockroaches in the control, oak litter, rubber, and topsoil treatments ( $P>0.05$ ); however, there was significant mortality in the cypress and pine straw treatments. The  $LT_{50}$  (95% CI) value for cypress was 37.36 (15.37-6,497) d; slope of  $1.81 \pm 0.66$ ;  $\chi^2 = 7.55$  and  $P=0.006$ . For pine straw the  $LT_{50}$  value was 12.54 (8.81-4.44x10<sup>5</sup>) d; slope of  $5.94 \pm 2.84$ ;  $\chi^2= 4.37$  and  $P=0.037$ .

**Choice Box Mulch Repellency.** Mean repellency of adult male Asian cockroaches ranged from 3.54 to 20.25% for oak mulch and the control, respectively (Table 2). Control boxes had the greatest means of  $20.25 \pm 3.09\%$  ( $P=0.0001$ ). Adult male Asian cockroaches were least repelled by the oak and pine straw mulch compared with the control, cypress, rubber, and topsoil mulches (Table 2). Repellency of all mulch treatments, except the pine straw and rubber declined linearly over time as they became acclimated in the Ebeling choice boxes (Fig. 1, Table 3). Repellency declined most rapidly in the top soil treatment (slope = -3.94) and least rapidly in the oak leaf mulch (slope = -0.70) (Table 3).

**Choice Box Mulch Toxicity.**  $LT_{50}$  values for adult male Asian cockroaches confined in Ebeling choice boxes ranged from 11.66-280.11 d for pine straw and topsoil, respectively (Table 4). However, there were no significant differences in toxicity among mulch and control treatments based on 95% CI overlap (Table 4).

**Physical Measurements.** Temperature ranged  $25.07 \pm 0.12$  to  $26.33 \pm 0.16^\circ\text{C}$  for pine straw and oak litter, respectively (Table 5). Relative humidity ranged from  $33.27 \pm 0.32\%$  for oak leaf litter to  $70.80 \pm 0.89\%$  for rubber mulch (Table 5). Light intensity ranged from 0.00 to  $4.53 \pm 1.20$  lux for topsoil and pine straw, respectively (Table 5).



Interstitial spaces ranged from 0 for topsoil to  $4.80 \text{ mm} \pm 0.93 \text{ mm}$  for pine straw (Table 5).

## **DISCUSSION**

The Asian cockroach has become a peridomestic pest around homes in southern Alabama (Hu et al. 2005, Snoddy and Appel 2008). Populations begin to increase in May and reach their zenith in early September; during this time, many of these cockroaches find their way into the home and become pests (Snoddy 2007). Brenner et al. (1988) found that the Asian cockroach preferred moist shady leaf mulch around homes. Most homes in southern Alabama have some type of mulch landscaping around them which could enhance populations of the Asian cockroach. Pest control operators not familiar with the Asian cockroach may misidentify it as a German cockroach and treat indoors, exposing home owners to unnecessary and ineffective pesticide residues. As with other peridomestic cockroaches such as the American and smokybrown, populations may be mediated by harborage preferences (Appel and Smith 1996). Appel and Smith (1996) examined the harborage preferences of larger peridomestic cockroaches (American, and smokybrown cockroaches) to several mulch and plant materials [juniper branches, *Juniperus horizontalis* L.; pine straw, *Pinus* spp.; soil; rocks; or grass, *Eremochola ophiuroides* (Muno) Hack, thatch, and dry soil]. They found none of the mulch treatments to be toxic to either cockroach, but in Ebeling choice boxes the smokybrown cockroach was significantly and consistently repelled by dry soil as opposed to the American cockroach that was not repelled by any mulch treatment (Appel and Smith 1996). Although the smokybrown cockroach preferred juniper branches, there were

significant proportions found in pine straw and under rocks. Humidity was greater under the juniper branches but light intensity was less under pine straw (Appel and Smith 1996). Smaller nymphs selected harborages with the smaller interstitial spaces than larger nymphs; pine straw had the smallest interstitial spaces of any of the mulches they tested (Appel and Smith 1996). Similarly, German cockroach nymphs prefer narrower harborages than larger individuals (Berthold 1967, Berthold and Wilson 1967, Koehler et al. 1994).

The objective of this research was to evaluate the mulch preferences of the Asian cockroach. With mulch preference, repellency, and toxicity data it is possible to incorporate mulch selection into an Integrated Pest Management (IPM) program for homeowners to reduce the populations of the Asian cockroach. The most common conventional practice is to treat a perimeter around the house or “zone of death” with a broad spectrum residual insecticide (Appel and Smith 2002). These insecticidal barriers have numerous draw backs which include rapid degradation of the insecticide during hot summer days, exposure of residues to animals and the environment, and non-discriminatory elimination of numerous beneficial arthropods (Appel and Smith 2002). An IPM program could manage Asian cockroach populations around homes and reduce insecticide use and exposure.

Nearly 90% of adult male Asian cockroaches preferred the pine straw and oak leaf litter in the large choice box arena after 7 d (Table 1). This is consistent with observations of field populations of the Asian cockroach (Hu et al. 2005, Snoddy and Appel 2008). Pine straw and oak leaf litter offer adult males larger interstitial spaces and lower light conditions (Table 5) as Appel and Smith (1996) found with American and

smokybrown cockroaches. Adult females (66%) preferred rubber mulch and oak leaf litter over most other mulches (Table 1). Adult females may favor the rubber mulch because it affords a safer, more protected environment for the nymphal stages. Rubber mulch would contain the largest number of conspecific nymphs and could promote the greatest survival and growth of their offspring. Kairomones and other pheromones may also influence the adult female cockroach preferences (Appel 1997). All nymphal stages of the Asian cockroach significantly preferred the rubber mulch (small, 48%; medium, 63%; and large, 55%) over all other mulches (Table 1). This is likely due in part to the smaller interstitial spaces (see e.g., Berthold 1967, Berthold and Wilson 1967, Koehler et al. 1994) and high relative humidity (Table 5) that result from the rubber mulch particles. These interstitial spaces could allow the nymphs to hide and become inaccessible to possible predators as well as providing darker harborage areas (Table 5) for this negatively phototactic species. Small interstitial spaces may also contain food giving the nymphs a competitive advantage by reducing competition with adults. The smaller interstitial spaces in the rubber mulch retained more moisture than most of the other mulches (Table 5).

Nymphal Asian cockroaches are much smaller and have significantly greater surface area to volume ratios than adults and would therefore desiccate more rapidly. Mulches with smaller interstitial spaces, and those that are composed of impermeable material such as rubber, retain greater humidity within the mulch (Table 5). Greater humidity and free moisture would decrease the saturation deficit and result in lower rates of desiccation of cockroaches within the mulch. In preliminary experiments, Appel determined (unpublished) Asian cockroaches to have significantly greater (up to 2-fold)

cuticular permeability values than German cockroaches and therefore desiccate more rapidly. Asian cockroaches probably select darker, more humid harborage areas to reduce their water loss.

In continuous exposure experiments, there was no significant mortality of adult male Asian cockroaches in the control, oak leaf litter, rubber, and top soil treatments ( $P>0.05$ ). There was significant mortality, however, in the cypress and pine straw mulches. This could be due to the essential oils present in these mulches. Essential oils are secondary plant substances (Isman 2006) that contain compounds such as monoterpenoids that give plants their aromatic characteristics. Phillips and Appel (2010) reported the toxicity of 12 essential oils to the closely related German cockroach. Cypress and pine contain two common essential oils [(+)- $\alpha$ -pinene and (-)- $\beta$ -pinene] that Phillips and Appel (2010) found to have fumigant toxicity against all cockroach stages. They suggest that essential oils could be used in an IPM program to control populations of German cockroaches inside homes. Cypress mulch and pine straw are used outdoors as landscaping materials where the peridomestic Asian cockroach occurs and are exposed to sunlight, temperature extremes, and humidity fluctuations. Therefore cypress mulch and pine straw would probably lose naturally occurring essential oils much faster than inside a home where the environment is consistently controlled. Cypress mulch is much larger and thicker mulch that would breakdown much more slowly than the thin, spindly pine straw mulch. Cypress mulch would therefore probably be a better choice for a landscaping mulch to be incorporate into an IPM program.

Ebeling choice box studies with adult male Asian cockroaches showed very little toxicity or repellency of the oak leaf litter and pine straw mulches (Tables 2 and 4). Adult

males were somewhat repelled by the control, rubber mulch, and topsoil (Table 2). Adult males preferred mulches that offered harborage areas where they could hide in interstitial spaces during the light photophase. Over time, repellency of the control, rubber mulch, and topsoil declined as the cockroaches acclimated and preferred the dark side of the Ebeling choice box (Fig. 1, Table 3). Although the Ebeling choice box experiments indicated that oak leaf litter and pine straw were significantly toxic, there were no significant differences between any of the mulch and control treatments based on overlap of the 95% CI (Table 4). These results indicate little biological significance to the choice box  $LT_{50}$  results and suggest that all of the treatments were relatively nontoxic. None of the mulches could therefore be used as insecticides.

From the standpoint of an IPM program it would be unwise to use oak leaf litter, pine straw, or the rubber mulch for landscaping around the home. Oak leaf litter and pine straw will surely attract and harbor large Asian cockroach populations. The synthetic rubber mulch would allow larger populations of nymphs to survive to adulthood resulting in large numbers of breeding adults. Although the bare topsoil showed the most repellency to the Asian cockroach it is impracticable to think a home owner would use bare ground around the home as landscaping. The cypress mulch was not preferred by any stage of the Asian cockroach and showed some toxicity to adult males. Of the materials we evaluated, cypress mulch would be the best choice in an IPM program designed to reduce the number of Asian cockroaches around the home.

## References

- Appel, A. G. 1990.** Laboratory and field performance of consumer bait formulations for German cockroach (Dictyoptera: Blattellidae) control. *J. Econ. Entomol.* 83: 153-159.
- Appel, A. G. 1992.** Performance of gel and paste bait products for for German cockroach (Dictyoptera: Blattellidae) control: laboratory and field studies. *J. Econ. Entomol.* 85: 1176-1183.
- Appel, A. G. 1997.** Nonchemical approaches to cockroach control. *J. Agric. Entomol.* 14: 271-280.
- Appel, A. G., and L. M. Smith. 1996.** Harborage preferences of American and smokybrown cockroaches (Dictyoptera: Blattidae) for common landscape materials. *Env. Entomol.* 25: 817-824.
- Appel, A. G., and L. M. Smith. 2002.** Biology and management of the smokybrown cockroach. *Annu. Rev. Entomol.* 47: 33-55.
- Atkinson, T. H., P. G. Koehler, and R. S. Patterson. 1999.** Reproduction and development of *Blattella asahinai* (Dictyoptera: Blattellidae). *Ann. Entomol. Soc. Am.* 84: 1251-1256.
- Berthold, R., Jr. 1967.** Behavior of the German cockroach, *Blattella germanica* (L.), in response to surface textures. *J. N.Y. Entomol.* 75: 148-153.
- Berthold, R., Jr. and B. R. Wilson. 1967.** Resting behavior of the German cockroach, *Blattella germanica* (L.). *Ann. Entomol. Soc. Am.* 60: 347-351.
- Brenner, R. J., P. G. Koehler, and R.S. Patterson. 1986.** A profile of America's newest import, the Asian Cockroach. U.S. Department of Agriculture, Agricultural Research Service. [Washington, D.C.: The Service] Nov/Dec p. 17-19.
- Brenner, R. J., P. G. Koehler, and R.S. Patterson. 1988.** Ecology, behavior and distribution of *Blattella asahinai* (Orthoptera: Blattellidae) in central Florida, USA. *Ann. Entomol. Soc. Am.* 81: 432-436.
- Ebeling, W. 1978.** Urban Entomology. University of California.

- Ebeling, W., R. E. Wagner, and D. A. Reiersen. 1966.** Influence of repellency on the blatticides. I. learned modification of behavior of the German cockroach. *J. Econ. Entomol.* 59: 1374-1388.
- Hu, X. P., A. G. Appel, and R. Vester. 2005.** Asian cockroach “invades” Alabama. *Pest Control. JAN* 41-42.
- Isman, M. B. 2006.** Botanical insecticides, deterrents, and repellents in modern agriculture and an increasingly regulated world. *Ann. Rev. Entomol.* 51: 45-66.
- Koehler, P. G., C. A. Strong, and R. S. Patterson. 1994.** Harborage width preferences of German cockroach (Dictyoptera: Blattellidae) adults and nymphs. *J. Econ. Entomol.* 87: 699-704.
- Koehler, P. G., and R. S. Patterson. 1987.** The Asian roach invasion. *Natural History.* 96: 11, 28, 30, 32, 34-35.
- Kopanic, R. J., Jr., B. W. Sheldon, and C. G. Wright. 1994.** Cockroaches as vectors of Salmonella: laboratory and field trials. *J. Food Prot.* 57: 125-133.
- Lawless, L. S. 1999.** Morphological comparisons between two species of *Blattella* (Dictyoptera: Blattellidae). *Ann. Entomol. Soc. Am.* 92: 139-143.
- Mizukubo, T. 1981.** A revision of the genus *Blattella* (Blattaria: Blattellidae) of Japan. I. Terminology of the male genitalia and description of a new species from Okinawa Island. *Esakia* 17: 149-159
- Pfannenstiel, R. S., W. Booth, E. L. Vargo, and C. Schal. 2008.** *Blattella asahinai* (Dictyoptera: Blattellidae): A new predator of lepidopteran eggs in South Texas soybean. *Ann. Entomol. Soc. Am.* 101: 763-768.
- Phillips, A. K., and A. G. Appel. 2010.** Fumigant toxicity of essential oils to the German cockroach (Dictyoptera: Blattellidae). *J. Econ. Entomol.* 103: 781-790.
- Ross, M. H., and D. E. Mullins. 1988.** Nymphal and oothecal comparisons of *Blattella asahinai* and *Blattella germanica* (Dictyoptera: Blattellidae). *J. Econ. Entomol.* 81: 1645-1647.
- Roth, L. M. 1986.** *Blattella asahinai* introduced into Florida (Blattaria: Blattellidae). *Psyche* 93: 371-374.
- Roth, L. M., and E. R. Willis. 1957.** The medical and veterinary importance of cockroaches. Smithsonian Institute, Washington, DC.
- Roth, L. M., and E. R. Willis. 1960.** The biotic associations of cockroaches. Smithsonian Institute, Washington, DC.

**Rust, M.K., J. M. Owens, and D. A. Reiersen. 1995.** Understanding and controlling the German cockroach. Oxford University Press.

**SAS Institute. 2011.** SAS 9.1 Statistical analysis software. SAS Institute, Cary, NC.

**Schal, C., and R. L. Hamilton. 1990.** Integrated suppression of synanthropic cockroaches. *Annu. Rev. Entomol.* 35: 521-551.

**Snoddy, E. T. 2007.** Distribution and population dynamics of the Asian cockroach (*Blattella asahinai* Mizukubo) in Southern Alabama and Georgia. Master of Science Thesis, Auburn University.

**Snoddy, E. T., and A. G. Appel. 2008.** Distribution of *Blattella asahinai* (Dictyoptera: Blattellidae) in Southern Alabama and Georgia. *Ann. Entomol. Soc. Am.* 101: 397-401.

**Systat Software, Inc. 2011.** SigmaPlot for Windows, version 12.2. Systat Software, Inc., San Jose, CA.

**Tatfeng, Y. M., M. U. Usuanlele, A. Orukpe, A. K. Digban, M. Okodua, F. Oviasogi, and A. A. Turay. 2005.** Mechanical transmission of pathogenic organisms: the role of cockroaches. *J. Vector Borne Diseases* 42: 129-134.

**Throne, J. E., D. K. Weaver, V. Chew, and J. E. Baker. 1995.** Probit analysis of correlated data: multiple observations over time at one concentration. *J. Econ. Entomol.* 88: 1510-1512.



**Table 1. Mulch preferences of different stages of the Asian cockroach in large arena experiments.**

Mulch	n	Stages <sup>a</sup>					
		Small	Medium	Large	Male	Female	Total
cypress	6	3.33 ± 3.33a	3.00 ± 3.00b	7.67 ± 2.80b	1.50 ± 1.50c	13.83 ± 5.29ab	6.33 ± 1.94cd
oak	6	6.67 ± 4.23ab	21.33 ± 4.06ab	21.67 ± 3.26ab	54.33 ± 6.30a	34.00 ± 3.89a	29.17 ± 2.41b
pine	6	8.33 ± 5.43ab	13.17 ± 5.59ab	15.50 ± 4.74ab	33.00 ± 6.33ab	20.17 ± 7.43ab	19.17 ± 3.72bc
rubber	6	48.33 ± 13.08a	62.50 ± 6.51a	55.17 ± 8.39a	9.83 ± 5.08bc	32.00 ± 4.84a	45.33 ± 5.21a
topsoil	6	0b	0b	0b	0c	0b	0d

<sup>a</sup>Means (± SE) within columns followed by different letters are significantly different (P<0.05; Kruskal-Wallis ANOVA on ranks, Tukey pairwise multiple comparison test).

**Table 2. Repellency of mulches to adult male Asian cockroaches in Ebeling choice boxes.**

Treatment	<i>n</i>	Mean $\pm$ SE <sup>a</sup>	DF	<i>t</i>	<i>P</i>
control	60	20.25 $\pm$ 3.09a	27	6.53	0.0001
cypress	60	6.07 $\pm$ 3.55b	27	1.71	0.0988
oak	60	3.54 $\pm$ 3.55b	27	1.00	0.3278
pine	60	3.97 $\pm$ 3.58b	27	1.11	0.2774
rubber	60	15.72 $\pm$ 3.55a	27	4.42	0.0001
topsoil	60	17.84 $\pm$ 3.55a	27	5.02	0.0001

<sup>a</sup>Repeated measures ANOVA followed by a least squares means test.

**Table 3. Linear regressions of the repellency of mulches and untreated control to adult male Asian cockroaches tested in Ebeling choice boxes.**

Treatment	<i>n</i>	Slope ± SE	Intercept ± SE	<i>r</i> <sup>2</sup>	F	<i>P</i>
control	7	-2.09 ± 0.75	27.166 ± 3.327	0.61	7.961	0.0370
cypress	7	-2.85 ± 1.08	17.134 ± 4.850	0.58	6.903	0.0467
oak	7	-0.70 ± 0.26	5.983 ± 1.158	0.59	7.251	0.0432
pine	7	- <sup>a</sup>	-	-	-	0.7686
rubber	7	-1.78 ± 0.73	21.741 ± 3.266	0.54	5.928	0.0590
topsoil	7	-3.94 ± 0.38	32.586 ± 1.694	0.96	107.972	0.0001

<sup>a</sup>Regression not significant at *P*<0.05.

**Table 4. Toxicity of mulches to adult male Asian cockroaches confined in Ebeling choice boxes.**

Treatment	<i>n</i>	Slope ± SE	LT <sub>50</sub> d (95%CI)	$\chi^2$	<i>P</i>
control	36	1.23 ± 0.37	66.39 (23.55-3183)	11.27	0.0008
cypress	36	1.86 ± 0.64	34.06 (15.04-2144)	8.36	0.0038
oak	36	4.39 ± 1.14	12.38 (8.91-58.75)	9.16	0.0025
pine	36	2.32 ± 1.07	11.66 (6.62-1.1x10 <sup>6</sup> )	4.67	0.0307
rubber	36	1.39 ± 0.39	32.37 (15.29-380.17)	12.93	0.0003
topsoil	36	0.72 ± 0.35	280.11 (33.02-9.02x10 <sup>52</sup> )	4.14	0.0418

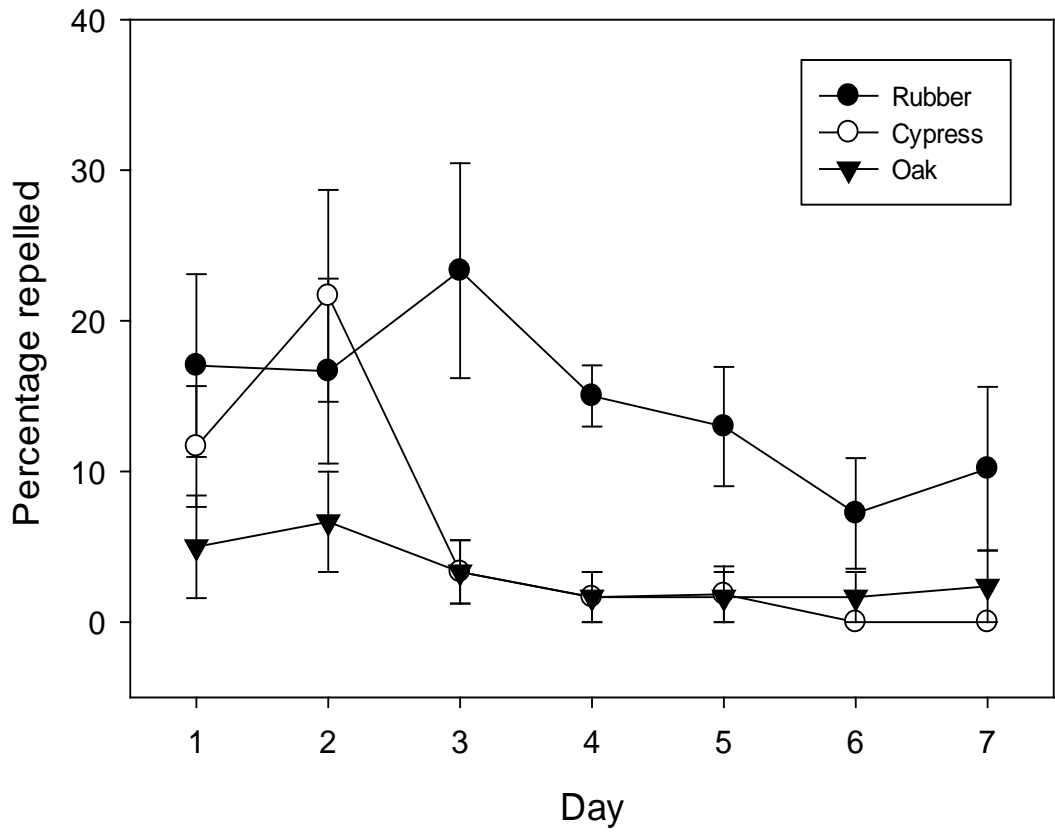
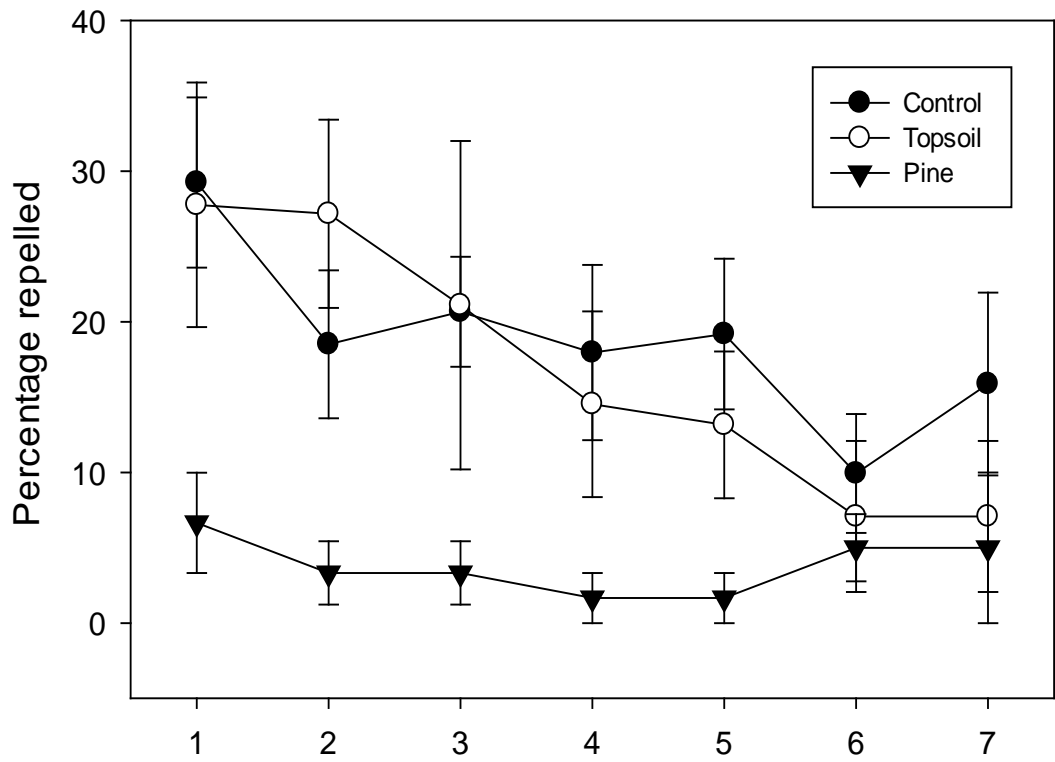

**Figure 1. Repellency of mulches and untreated control to adult male Asian cockroaches tested in Ebeling choice boxes.**

## Chapter 6

### Light Preferences of the Asian Cockroach *Blattella asahinai* Mizukubo (Dictyoptera: Blattellidae)

#### Introduction

The Asian cockroach, *Blattella asahinai* Mizukubo, is a peridomestic pest from Okinawa, Japan first described in 1981 (Mizukubo, 1981), and introduced into Florida in 1986 (Roth 1986). The first account of the Asian cockroach in the United States was limited to three adjacent counties around Tampa Florida (Brenner et al. 1986, Koehler and Patterson 1987); by 2007, all 67 counties in Florida had established populations (P.G. Koehler, personal communication). The Asian cockroaches were first identified outside of Florida in 2003 in Dothan, Alabama (Hu et al. 2005). These cockroaches are currently distributed in seven counties in Alabama and eight counties in Georgia (Snoddy and Appel, 2008). This species was reported in south Texas in 2008 (Pfannenstiel et al. 2008). The Asian cockroach is very similar in size and appearance to the German cockroach, *Blattella germanica* (L.) (Roth 1986). The German cockroach is a domestic pest which only lives indoors, does not fly, and is negatively phototaxic (Ebeling 1978, Rust et al. 1995). In contrast, Asian cockroaches live outdoors as a peridomestic pest, is a strong flyer, and positively phototaxic (Brenner et al. 1988, Snoddy and Appel 2008). The Asian cockroach is attracted to lights at night and often enters homes (Snoddy 2007).

Populations of the Asian cockroach start to increase in late May and reach their zenith in late August and then sharply decline with the onset of cool fall weather (Snoddy

2007). This peridomestic pest becomes a nuisance to homeowners when they enter the home. Since the Asian cockroach lives outdoors it is in contact with animal feces and a plethora of pathogens from its mulch harborages, it can mechanically vector these pathogens such as *Salmonella* spp. to food work surfaces, plates, silverware, and food stuffs when it enters the home (Roth and Willis 1957, 1960, Kopanic et al. 1994, Tattfeng et al. 2005). Cockroach feces and body parts can be allergenic to sensitive individuals (Ebeling 1978, Ebeling et al. 1966, Schal and Hamilton 1990). Most of these allergies are asthmatic in nature and, in some cases, can be life threatening (Ebeling 1978, Ebeling et al. 1966, Schal and Hamilton 1990).

Several basic biological studies have been conducted in the laboratory, but few field studies have been attempted (Ross and Mullins 1988, Brenner et al. 1988, Lawless 1999, Atkinson et al. 1999). Asian cockroaches prefer moist leaf litter and shady areas (Brenner et al. 1988). Most homes have some type of landscape mulch around it and thus ideal conditions exist for large populations of the Asian cockroach to build up and find their way into the home. Most homes also have outside lighting which attracts the Asian cockroach because it is positively phototaxic (Brenner et al. 1986, Brenner et al. 1988, Koehler et al. 1987, Snoddy 2007). This species is a strong flyer and may be attracted to certain types of lights (Brenner et al. 1986, Brenner et al. 1988, Koehler et al. 1987, Snoddy 2007) and not be controlled by an insecticidal barrier. An IPM program which incorporates lights not preferred by the Asian cockroach could manage populations around homes and reduce insecticide use and exposure.

The objective of this study was to evaluate the light preferences of the Asian cockroach in an outdoor urban environment. Light preference data could be used as part



of an IPM program for homeowners. By changing the kind of lights used around a home to ones that are not preferred, populations of the Asian cockroach may be reduced.

## **Materials and Methods**

**Insects and Field Site.** A field population of Asian cockroaches in Landmark Park, Dothan, Alabama (31° 17' 18.93" N, 85° 22' 11.91" W) was used in this study. Landmark Park is dominated by pine straw mulch and oak leaf litter which harbors consistent populations of the Asian cockroach (Hu et al. 2005, Snoddy 2007, Snoddy and Appel 2008, Appel et al. 2009). Data were collected on five consecutive nights in June 2011. Weather conditions were similar each night, and each night had a dark moon phase as so not to interfere with the light treatments. Temperature, relative humidity, and wind speed was used from hourly data recorded at the Dothan Regional Airport which is located 5 km west of Landmark Park.

**Light Treatments.** Lights consisted of a red, yellow or "bug light", LED, compact fluorescent lamp (CFL), and incandescent light bulb (Table 1). Lights were placed in a 110 v aluminum reflector light base (Home Depot, Atlanta GA.) and clamped to the top of a 1 m tall, 0.60 m by 1.2 m wide, wooden pole (non- treated lumber) mounted to a 0.6 m x 0.6 m plywood base (12.7 mm thickness, sanded, non-treated plywood). The pole and base were painted white with Krylon<sup>®</sup> multi-purpose satin spray paint (The Sherwin-Williams Company, Cleveland, Ohio 44115-1075) and was placed at the rear of a 0.83 m x 1.2 m white (200 thread count) sheet (Walmart, Bentonville, Arkansas 72716-8611). The light treatment was projected onto the sheet and base. Light treatments were set up in a randomized complete block design. Light treatments were

placed 7.62 m apart from one another. Treatments were randomized each night for five nights ensuring that a light treatment was never placed where it had been before. In preliminary studies we found that Asian cockroaches were attracted to lights just after dark and no longer were observed after 23:00 hours. Lights were turned on at 19:00 h and turned off at 1:00 h.

**Sampling Method.** Treatments were examined every 15 min and the number and stage (male, female, nymphs) of the Asian cockroach was recorded. If an Asian cockroach was on the light pole, base, or sheet it was recorded for that light treatment.

**Data Analysis.** Data were collected between 19:00 to 01:00 h and the number of cockroaches attracted to each treatment plotted over time. Data from most active periods were used for further analysis. The goal of the experiment was to determine the attractiveness of the Asian cockroach to various types of lights irrespective of the activity period therefore we collapsed the data for 20:30 to 23:00 h. Data were totaled by light type each night and subjected to a one-way analysis of variance (ANOVA) to determine if there were differences in the lights (Systat 2011); days were considered replicates. Data did not meet the assumptions of a regular parametric test so a Kruskal-Wallis one-way ANOVA on ranks was performed (Systat 2011). Weather data were subjected to description analysis (Systat 2011) to determine the mean (minimum and maximum) temperature, relative humidity, and wind speed during the time of the data collection. A Pearson correlation (Systat 2011) was used to determine if there was a relationship between cockroach numbers and weather.

## RESULTS

Only adult females and males of the Asian cockroach were attracted to the light treatments, no nymphal stages were ever observed. Asian cockroaches first appeared at the light treatments at 20:30 h and none were observed after 23:15 h. No cockroaches were observed at any time period at the red or LED light treatments. Only one cockroach was observed at the yellow light during the entire 5 d study (Table 1, Fig. 1, Fig. 2). The mean number of adults ranged from 0 to  $11.00 \pm 4.30$  in the red and incandescent light treatments, respectively (Table 1). The Asian cockroach was most attracted to the incandescent light bulb ( $10.20 \pm 6.06$ ) and the compact fluorescent lamp ( $11.00 \pm 4.30$ ) compared with all other light treatments (Table 1). Weather conditions ranged from a maximum temperature of  $36.7^{\circ}\text{C}$  to a minimum of  $24.4^{\circ}\text{C}$ , average RH between  $48.3 \pm 4.1\%$  and  $71.9 \pm 7.9\%$ , and wind speed of  $7.6 \pm 3.2$  kph to  $14.5 \pm 1.2$  kph during 19:00 to 01:00 h. Correlation analysis showed attraction of Asian cockroaches positively correlated with relative humidity ( $0.333$ ,  $P=0.0009$ ), but negatively correlated with temperature ( $-0.442$ ,  $P>0.0001$ ) and wind speed ( $-0.232$ ,  $P=0.0238$ ).

## DISCUSSION

The Asian cockroach has been a peridomestic pest in southern Alabama since its discovery (Hu et al. 2005, Snoddy and Appel 2008). Populations begin to increase in late May and reach their zenith in early September; during this time, many of these cockroaches find their way into homes and become pests (Snoddy 2007). Brenner et al. (1988) found that the Asian cockroach prefers shady and moist leaf litter mulch around homes. Other mulches such as inorganic shredded rubber and pine straw is also attractive (Snoddy and Appel, submitted). Some type of landscaping mulch is used around most

homes so there is close proximity between cockroaches and houses. Most homes have outside lighting which will attract the Asian cockroach because it is positively phototactic during the scotophase.

The most common practice for control of peridomestic cockroaches is to treat a narrow perimeter around the outside of the house with a broad spectrum residual insecticide (Appel and Smith 2002). These insecticidal barriers have numerous drawbacks which include rapid degradation of the insecticide during hot summer days, exposure of residues to animals and the environment, and non-discriminatory elimination of numerous beneficial arthropods (Appel and Smith 2002).

The Asian cockroach is a strong flyer and is attracted to lights (Snoddy 2007) and therefore may not be controlled by an insecticidal barrier. Because Asian cockroaches are attracted to lights, adults tend to congregate around outside porch lamps by doors and enter homes when doors are opened at night (Koehler et al. 1987). Flying adults are also attracted to lighted windows where they venture indoors and fly to reading lamps, television sets, and kitchen lights (Koehler et al. 1987) becoming a nuisance. An IPM program which incorporates non attractive lighting around the outside of the home could reduce the number of adults entering the home and reduce insecticide use and exposure. Asian cockroaches were not attracted to red or LED lights, and only one cockroach was attracted to the yellow light (Table1, Fig. 1, Fig. 2). This result is consistent with that of Appel and Rust (1986) who found that red light does not affect the behavior of the smokybrown cockroach, *Periplaneta fuliginosa* (Fab.), which is also a peridomestic pest. Guthrie and Tindal (1968) reported that the American cockroach, *P. americana* (L.), does not detect red light either. Koehler et al. (1987) found that the closely related German

cockroach could not detect red or gold lights. Agee (1973) also found that adult bollworms, *Heliothis zea*, and Tobacco budworms, *H. virescens* (Fab.), were not responsive to red light. Rust et al. (1995) noted that red light could be detrimental to the closely related German cockroach based on work by Ball (1958). Insects in the order Hymenoptera are not believed to be able to see the wavelength of the LED lights either (Dr. Charles Ray, personal communications). The order Hymenoptera contains bees and wasps which have highly developed eyesight and see across most light spectrums (Triplehorn and Johnson 2005). Since most cockroaches are believed to be unable to see the red or LED light spectrum this explains the results for those two light treatments.

Attractiveness was recorded for adult cockroaches if they were observed on the ground cloth, pole, and light itself. It has been hypothesized that in warm humid habitats sex pheromones tend to rise along thermal gradients (Schal 1982). Adult male smokybrown cockroaches tend to perch higher than females (Appel and Rust 1986) supporting Schal's hypothesis. Gemeno and Schal (2004) found that in cockroaches that are good flyers, such as many peridomestic species, females release long as well as short-range sex pheromones. Sex pheromones rise on thermal gradients in warm humid areas it would be to the male cockroach's advantage to perch as high as possible to detect these long range pheromones (Schal 1982). Therefore any adult cockroach that was on the pole or lights itself was counted.

Maximum activity of the Asian cockroach was 2-4 h after the onset of the scotophase, and then declined sharply (Fig. 1) which is consistent with the smokybrown cockroach (Appel and Rust 1986). The closely related German cockroach exhibits similar activity that begins at dusk and reaches its maximum activity several hours after the onset

of the scotophase (Metzger 1995). Adult male German cockroaches had a longer activity period than that of females or nymphs (Metzger 1995). Asian cockroaches, particularly in the field should have a natural circadian rhythm of activity similar to that of the German cockroach (Driesig and Nielson 1971, Beck 1980, Koehler et al. 1987, Leppla et al. 1989, Metzger 1995) and other peridomestic cockroach species (Guthrie and Tindal 1968, Appel and Rust 1986).

Weather data was collected and analyzed for any correlation between adult Asian cockroach activity and weather conditions (Table 2). More adult Asian cockroaches were attracted to lights when the temperature was declining. There was no significant correlation between the number of adult Asian cockroaches and either RH or wind speed. Temperature could also be a factor in the activity periods adult Asian cockroaches. Daytime temperatures during the test dates were  $> 37^{\circ}\text{C}$ . Snoddy (2007) found that Asian cockroaches will burrow into leaf litter and soil to escape extreme weather conditions (temperature and relative humidity), it is possible that temperatures needed to decline before cockroaches would emerge from their harborages before flying to lights.

Asian cockroaches were most attracted to incandescent and compact fluorescent lights (Table 1, Fig. 2). Since most homes in southern Alabama have these types of lights it is plausible that lighting is compounding the Asian cockroach pest problem. If a homeowner is using landscaping mulch that is favorable to the Asian cockroach coupled with lights that are attractive, it is likely that the homeowner is creating an unnecessary pest problem around the home. By replacing incandescent and compact fluorescent lights with red, yellow, or LED lights the homeowner could reduce the number of Asian cockroaches entering the home and being attracted to nearby mulch. This would be a vital

part of an IPM program that could reduce populations of cockroaches around the home without the negative impacts of insecticides.

## References

- Agee, H. R. 1973.** Spectral sensitivity of the compound eyes of field-collected adult bollworms and tobacco budworms. *Ann. Entomol. Soc. Am.* 66: 613-615.
- Appel, A. G., M. J. Eva, E. T. Snoddy. 2009.** Distribution of the Asian cockroach, *Blattella ashinai* (Dictyoptera: Blattidae) in Dothan, Alabama. *J. of Alabama Academy of Science* Vol. 80, No. 1: 1-7.
- Appel, A. G., and M. K. Rust. 1986.** Time-activity budgets and spatial distribution patterns of the smokybrown cockroach, *Periplaneta fuliginosa* (Dictyoptera: Blattidae). *Ann. Entomol. Soc. Am.* 79: 104-108.
- Appel, A. G., and L. M. Smith. 2002.** Biology and management of the smokybrown Cockroach. *Annu. Rev. Entomol.* 47: 33-55.
- Atkinson, T. H., P. G. Koehler, and R. S. Patterson. 1999.** Reproduction and development of *Blattella asahinai* (Dictyoptera: Blattellidae). *Ann. Entomol. Soc. Am.* 84: 1251-1256.
- Ball, H. J. 1958.** The effect of visible spectrum irradiation on growth and development in several species of insects. *J. Econ. Entomol.* 51:573-578.
- Beck, S. D. 1980.** Insect photoperiodism, 2<sup>nd</sup> ed. Academic, New York.
- Brenner, R. J., P. G. Koehler, and R. S. Patterson. 1986.** A profile of America's newest import, the Asian Cockroach. U.S. Department of Agriculture, Agricultural Research Service. [Washington, D.C.: The Service] Nov/Dec p. 17-19.
- Brenner, R. J., P. G. Koehler, and R. S. Patterson. 1988.** Ecology, behavior and distribution of *Blattella asahinai* (Orthoptera: Blattellidae) in central Florida, USA. *Ann. Entomol. Soc. Am.* 81: 432-436.
- Dreisig, H. and E. T. Nielson. 1971.** Circadian rhythms of locomotion and its temperature dependence in *Blattella germanica*. *J. Exp. Biol.* 54: 187-189.
- Ebeling, W. 1978.** Urban Entomology. University of California.
- Ebeling, W., R. E. Wagner, and D. A. Reiersen. 1966.** Influence of repellency on the blatticides. I. learned modification of behavior of the German cockroach. *J. Econ. Entomol.* 59: 1374-1388.



**Gemeno, C., and C. Schal. 2004.** Sex pheromones of cockroaches, pp. 179-247, *In* R. T. Cadre and J. G. Millar, *Advances in Insect Ecology*. Cambridge University Press, Cambridge, UK.

**Guthrie, D. M., and A.R. Tindall. 1968.** *The biology of the cockroach*. Edward and Arnold Publishers Ltd., London.

**Hu, X. P., A. G. Appel, and R. Vester. 2005.** Asian cockroach “invades” Alabama. *Pest Control*. JAN 41-42.

**Koehler, P. G., H. R. Agee, N. C. Leppla, and R. S. Patterson. 1987.** Spectral sensitivity and behavioral response to light quality in the German cockroach (Dictyoptera: Blattellidae). *Ann. Entomol. Soc. Am.* 80: 820-822.

**Koehler, P. G., and R. S. Patterson. 1987.** The Asian roach invasion. *Natural History*. 96: 11, 28, 30, 32, 34-35.

**Kopanic, R. J., Jr., B. W. Sheldon, and C. G. Wright. 1994.** Cockroaches as vectors of Salmonella: laboratory and field trials. *J. Food Prot.* 57: 125-133.

**Lawless, L. S. 1999.** Morphological comparisons between two species of *Blattella* (Dictyoptera: Blattellidae). *Ann. Entomol. Soc. Am.* 92: 139-143.

**Leppla, N. C., P. G. Koehler, H. R. Agee. 1989.** Circadian rhythms of the German cockroach (Dictyoptera: Blattellidae): Locomotion in response to different photoperiods and wavelengths of light. *J. Insect Phys.* Vol. 35: 63-66.

**Metzger, R. 1995.** Behavior, pp. 49-76, *In* M. K. Rust, J. M. Owens, and D. A. Reieson, *Understanding and controlling the German cockroach*. Oxford University Press, New York.

**Mizukubo, T. 1981.** A revision of the genus *Blattella* (Blattaria: Blattellidae) of Japan. I. Terminology of the male genitalia and description of a new species from Okinawa Island. *Esakia* 17: 149-159

**Pfannenstiel, R. S., W. Booth, E. L. Vargo, and C. Schal. 2008.** *Blattella asahinai* (Dictyoptera: Blattellidae): A new predator of lepidopteran eggs in South Texas soybean. *Ann. Entomol. Soc. Am.* 101: 763-768.

**Ross, M. H., and D. E. Mullins. 1988.** Nymphal and oothecal comparisons of *Blattella asahinai* and *Blattella germanica* (Dictyoptera: Blattellidae). *J. Econ. Entomol.* 81: 1645-1647.

**Roth, L. M. 1986.** *Blattella asahinai* introduced into Florida (Blattaria: Blattellidae). *Psyche* 93: 371-374.

- Roth, L. M., and E. R. Willis. 1957.** The medical and veterinary importance of cockroaches. Smithsonian Institution, Washington, DC.
- Roth, L. M., and E. R. Willis. 1960.** The biotic associations of cockroaches. Smithsonian Institution, Washington, DC.
- Rust, M. K., J. M. Owens, and D. A. Reiersen. 1995.** Understanding and controlling the German cockroach. Oxford University Press.
- Schal, C. 1982.** Intraspecific vertical stratification as a mate-finding mechanism in tropical cockroaches. *Science* 215: 1405-1407.
- Schal, C., and R. L. Hamilton. 1990.** Integrated suppression of synanthropic cockroaches. *Annu. Rev. Entomol.* 35: 521-551.
- Snoddy, E. T. 2007.** Distribution and population dynamics of the Asian cockroach (*Blattella asahinai* Mizukubo) in Southern Alabama and Georgia. Master of Science Thesis, Auburn University.
- Snoddy, E. T., and A. G. Appel. 2008.** Distribution of *Blattella asahinai* (Dictyoptera: Blattellidae) in Southern Alabama and Georgia. *Ann. Entomol. Soc. Am.* 101: 397-401.
- Systat Software, Inc. 2011.** SigmaPlot for Windows, version 12.2. Systat Software, Inc., San Jose, CA.
- Tatfeng, Y. M., M. U. Usuanlele, A. Orukpe, A. K. Digban, M. Okodua, F. Oviasogi, and A. A. Turay. 2005.** Mechanical transmission of pathogenic organisms: the role of cockroaches. *J. Vector Borne Diseases* 42: 129-134.
- Triplehorn, C. A., and N. F. Johnson. 2005.** Borror and DeLong's Introduction to the Study of Insects. 7<sup>th</sup> ed. Thompson-Brooks/Cole. Belmont, CA.

**Table 1. Type of lights and mean number of Asian cockroaches**

Light Color	Light Type	Company	Wavelength (nm)	Watts/Lumens	Mean $\pm$ SE <sup>a</sup>
Red	Incandescent	Phillips Inc. Somerset, NJ.	610- 760	100/1690	0 b
Yellow	Fluorescent	EcoSmart Atlanta, GA.	570-590	14/600	0.20 $\pm$ 0.48 b
LED	LED	Petzl Clearfield, UT.	Broad Spectrum	3/60	0 b
CFL	Fluorescent	Phillips Inc. Somerset, NJ.	Broad Spectrum	23/1600	10.20 $\pm$ 6.06 a
INC	Incandescent	Sylvania Inc. St. Marys, PA.	Broad Spectrum	100/1690	11.00 $\pm$ 4.30 a

<sup>a</sup> Mean  $\pm$  SE = average number of adult Asian cockroaches observed per night over 5 consecutive nights.

**Table 2. Weather data for light preference experiments at Landmark Park, Houston County, Dothan, AL.**

Date	Max Temp, °C	Min Temp, °C	Avg ( $\pm$ SE) Temp, °C	Avg ( $\pm$ SE), % RH	Wind speed ( $\pm$ SE), kph
3 JUN 2011	36.7	25.6	30.3 $\pm$ 3.6	48.3 $\pm$ 4.1	14.5 $\pm$ 1.2
4 JUN 2011	26.7	24.4	25.3 $\pm$ 0.3	71.9 $\pm$ 7.9	7.6 $\pm$ 3.2
5 JUN 2011	34.4	27.2	29.9 $\pm$ 2.5	49.9 $\pm$ 3.8	12.7 $\pm$ 1.1
6 JUN 2011	36.1	24.4	29.9 $\pm$ 4.8	49.1 $\pm$ 7.6	14.2 $\pm$ 2.6
7 JUN 2011	28.3	24.4	26.1 $\pm$ 1.4	63.5 $\pm$ 1.2	10.0 $\pm$ 2.9

Weather data recorded at the Dothan Regional Airport less than 3 km from study sight.

## Light Preference of Adult Asian Cockroaches

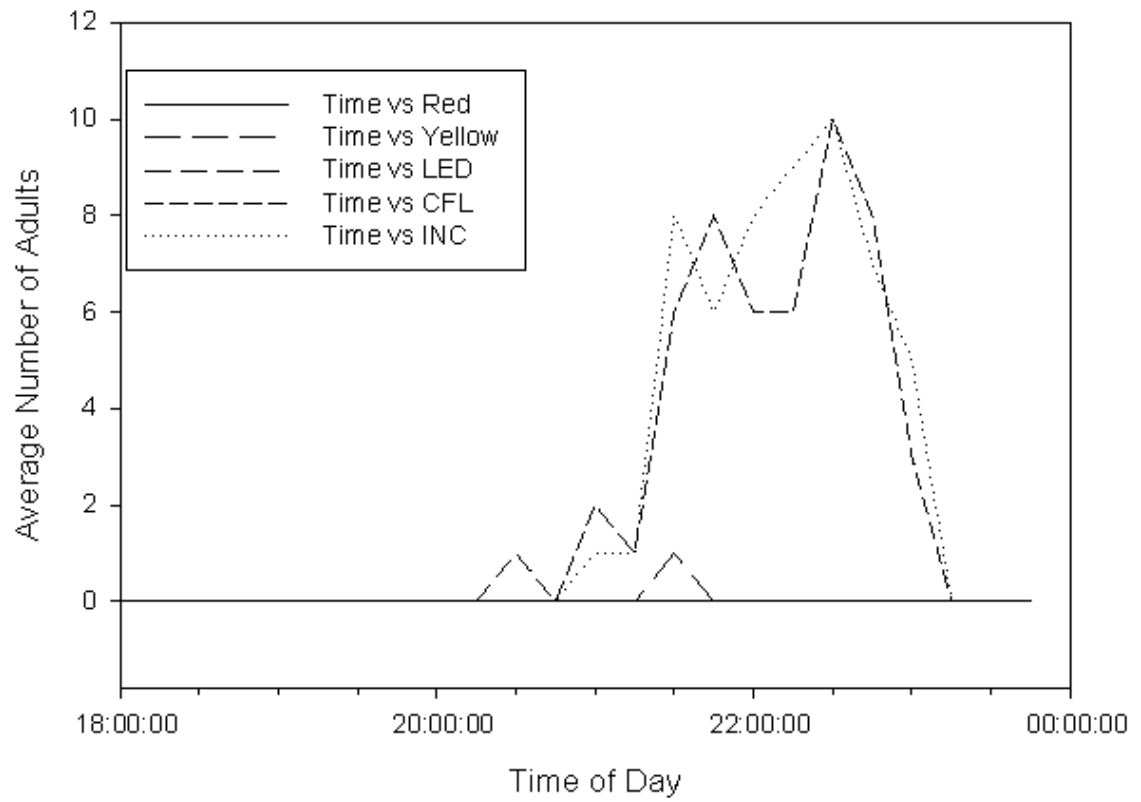

**Figure 1. Average number of adult Asian cockroaches by light and time period.**

Average Number of Adults by Light Treatment

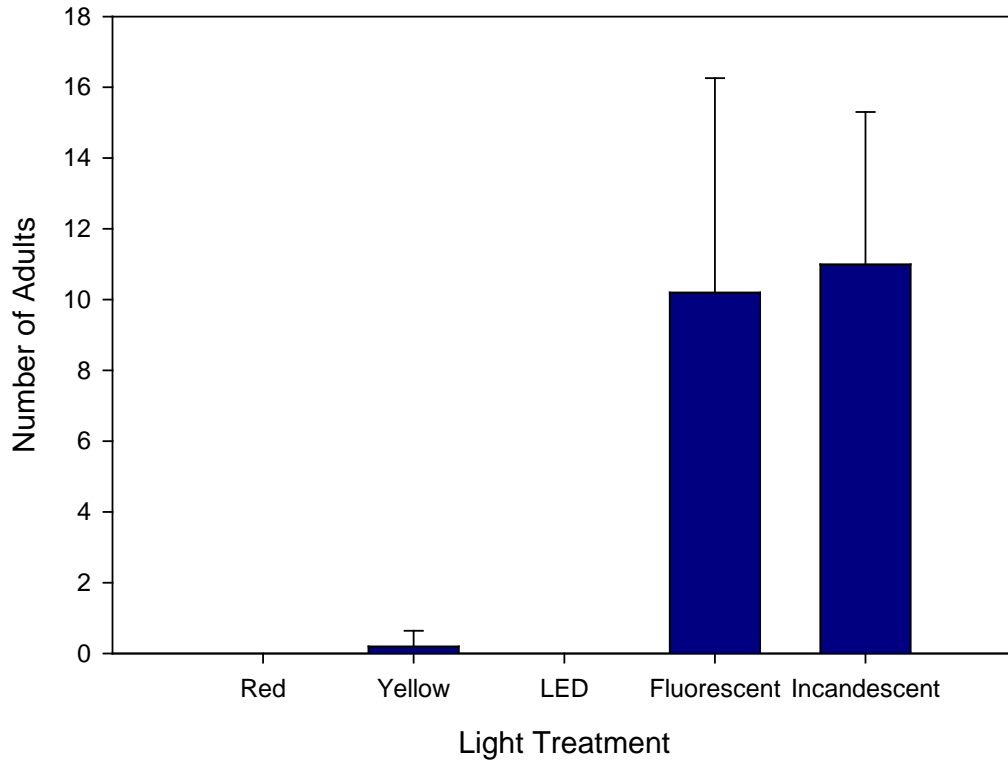

Figure 2: Average number of Asian cockroach adults by light treatment.