

AN EVALUATION OF THE USE OF SELF-CONSOLIDATING CONCRETE (SCC)
FOR DRILLED SHAFT APPLICATIONS

Except where reference is made to the work of others, the work described in this thesis is my own or was done in collaboration with my advisory committee. This thesis does not include proprietary or classified information.

Joseph Donald Bailey

Certificate of Approval:

Dan A. Brown
Gottlieb Associate Professor
Civil Engineering

Anton K. Schindler
Assistant Professor
Civil Engineering

George E. Ramey
Professor
Civil Engineering

Stephen L. McFarland
Dean
Graduate School

AN EVALUATION OF THE USE OF SELF-CONSOLIDATING CONCRETE (SCC)
FOR DRILLED SHAFT APPLICATIONS

Joseph Donald Bailey

A Thesis

Submitted to

The Graduate Faculty of

Auburn University

In Partial Fulfillment of the

Requirements for the

Degree of

Master of Science

Auburn University

August 8, 2005

AN EVALUATION OF THE USE OF SELF-CONSOLIDATING CONCRETE (SCC)
FOR DRILLED SHAFT APPLICATIONS

Joseph Donald Bailey

Permission is granted to Auburn University to make copies of this thesis at its discretion, upon the request of individuals or institutions and at their expense. The author reserves all publication rights.

Signature of Author

Date

Copy sent to:

Name

Date

AN EVALUATION OF THE USE OF SELF-CONSOLIDATING CONCRETE (SCC)
FOR DRILLED SHAFT APPLICATIONS

Joseph Donald Bailey

Master of Science, August 8, 2005
(B.S. Auburn University 2002)

234 Typed Pages

Directed by Dr. Anton K. Schindler and Dr. Dan. A. Brown

In drilled shaft construction, the recent development of sophisticated techniques for integrity and load testing has lead to the ability to asses the quality of drilled shaft foundations in terms of integrity and load carrying capabilities after they have been cast. Although this ability has lead to better assessment of drilled shaft foundations, it has also given insight to problems that are associated with materials and construction practices that has lead to defects or less than optimal performance for drilled shaft foundations.

This study examines the more common problems associated with drilled shaft foundations to emphasize the importance of constructability in design and workability in the construction materials. The majority of these problems consist of the failure to adequately consider one or more of the following issues:

- Workability of concrete for the duration of the pour
- Compatibility of the highly congested rebar cages and concrete being placed
- Bleeding and segregation

The main purpose of this study is to evaluate the use of self-consolidating concrete (SCC) as a viable material to overcome these issues due to its high flowability, passing ability, resistance to segregation, and reduced bleeding. A laboratory study will examine the difference between ordinary drilled shaft concrete and self-consolidating concrete (SCC) for both fresh and hardened properties. The fresh properties include filling ability, passing ability, segregation resistance, workability over time, bleeding characteristics, and controlled setting, while the hardened properties include the comparison of the compressive strength, elastic modulus, drying shrinkage, and permeability.

The laboratory results for both the ordinary drilled shaft concrete (ODSC) and SCC mixtures were evaluated and compared. The results show that SCC can be used to address many of the problems associated with drilled shaft construction because of the inherent workability, passing ability, resistance to segregation, and reduced bleeding of this type of concrete. Furthermore, the data suggest that the use of SCC in drilled shaft applications can provide similar or improved hardened concrete properties, which includes the compressive strength, elastic modulus, drying shrinkage, and permeability. However, some potential concerns for this material in drilled shaft applications include the general and overall lack of experience and research, lack of standardized tests, lack of well-defined mixture proportioning, and larger changes in workability compared to ODSC mixtures.

Style manual or journal used The Chicago Manual of Style _____

Computer software used Microsoft Word, Microsoft Excel, Microsoft Powerpoint _____

TABLE OF CONTENTS

LIST OF TABLES	x
LIST OF FIGURES	xii
CHAPTER ONE: INTRODUCTION.....	1
1.1 Statement of problem.....	1
1.2 Research Objectives.....	3
1.3 Research Scope.....	4
CHAPTER TWO: SELF-CONSOLIDATING CONCRETE.....	5
2.1 Introduction.....	5
2.2 SCC Testing Procedures.....	7
2.2.1 Slump Flow Test	
2.2.2 L- Box Test	
2.2.3 J-Ring Test	
2.2.4 Segregation Column Test	
2.3 Fresh Concrete Properties.....	18
2.3.1 Rheology	
2.3.2 Filling Ability	
2.3.3 Passing Ability	
2.3.4 Segregation Resistance	
2.4 Hardened Concrete Properties.....	29
2.4.1 Compressive Strength	
2.4.2 Modulus of Elasticity	
2.4.3 Drying Shrinkage	
2.4.4 Permeability	
2.5 Summary and Conclusions.....	48
CHAPTER THREE: EXPERIENCES WITH DRILLED SHAFT CONCRETE.....	52
3.1 Introduction.....	52
3.2 Workability of Drilled Shaft Concrete.....	53
3.3 Compatibility between Congested Rebar Cages and Concrete.....	74

3.4 Segregation and Bleeding.....	81
3.5 Summary and Conclusions.....	87
CHAPTER FOUR: LABORATORY TESTING PROGRAM AND MATERIALS	89
4.1 Introduction	89
4.2 Requirements for ODSC and SCC Mixtures	89
4.3 Laboratory Testing Program	91
4.3.1 Phase I – Effect of Type and Dosage of HRWRA	
4.3.2 Phase II – Effect of Retarder Dosage	
4.3.3 Phase III – Appropriate SCC Mixing Procedure	
4.3.4 Phase IV – Selection of SCC Properties	
4.3.5 Phase V – Methods to Modify the Viscosity of SCC Mixtures	
4.4 Raw Material Sources.....	112
4.4.1 Cementitious Materials	
4.4.2 Aggregates	
4.4.3 Chemical Admixtures	
CHAPTER FIVE: LABORATORY EQUIPMENT, SPECIMENS, AND PROCEDURES	126
5.1 Introduction	126
5.2 Batching and Mixing Procedure	127
5.3 Fresh Property Testing	129
5.3.1 Slump Test	
5.3.2 Slump Flow Test	
5.3.3 J-Ring Test	
5.3.4 L-Box Test	
5.3.5 Segregation Column Test	
5.3.6 Bleeding	
5.3.7 Unit Weight and Air Content	
5.3.8 Making and Curing Specimens	
5.3.9 Time of Set	
5.4 Hardened Concrete Properties	145
5.4.1 Compressive Strength	
5.4.2 Modulus of Elasticity	
5.4.3 Drying Shrinkage	
5.4.4 Permeability	

CHAPTER SIX: PRESENTATION AND ANALYSIS OF RESULTS	151
6.1 Introduction	151
6.2 Phase I - Selection of Type and Dosage of HWRWA	151
6.3 Phase II – Effect of Retarder Dosage	153
6.4 Phase III - Appropriate SCC Mixing Procedure	156
6.5 Phase IV - Selection of SCC Properties	158
6.5.1 Fresh Concrete Properties and Workability	
6.5.2 Segregation and Bleeding Results	
6.5.3 Passing Ability: J-Ring and L-Box	
6.5.4 Compressive Strength	
6.5.5 Modulus of Elasticity	
6.5.6 Drying Shrinkage	
6.5.7 Permeability	
6.5.8 Comparison between Laboratory and Field Conditions	
6.6 Phase V - Methods to Modify the Viscosity of SCC Mixtures	190
6.6.1 Fresh Concrete Properties	
6.6.2 Hardened Concrete Properties	
6.6.3 Effect of VMA on Fresh Concrete Properties	
6.7 Summary of Research Findings.....	210
CHAPTER SEVEN: PROPOSED EXPERIMENTAL FIELD STUDY.....	214
7.1 Introduction	214
7.2 Test Shafts	215
7.3 Fresh Concrete Property Testing	215
7.4 Hardened Concrete Property Testing	216
7.5 Placement Monitoring	217
7.6 Testing of Non-exhumed Shafts	217
7.7 Testing of Exhumed Shafts	218
7.8 Instrumentation	218
CHAPTER EIGHT: SUMMARY, CONCLUSIONS, AND RECOMMENDATIONS.	219
8.1 Introduction.....	219
8.2 Summary and Conclusions	219
8.3 Recommendations.....	222

LIST OF TABLES

Table 2.1	Visual Stability Index (VSI) Rating.....	12
Table 2.2	J-Ring Passing Ability Rating.....	15
Table 2.3	Compressive Strength Results from Turcry et al.(2003).....	35
Table 2.4	Mixture Proportions (Kim et al. 1998).....	43
Table 4.1	Concrete Mixture Proportions for Phase I	93
Table 4.2	Concrete Mixture Proportions for Phase II	95
Table 4.3	Concrete Mixture Proportions for Phase III	98
Table 4.4	Concrete Mixture Proportions for Phase IV	103
Table 4.5	Concrete Mixture Proportions for Phase V	110
Table 4.6	Chemical Analysis Results for the Giant Type I Cement	113
Table 4.7	Chemical Analysis Results for the SEFA Group Class F Fly Ash	114
Table 4.8	Chemical Analysis Results for the Micron 3 Fly Ash	115
Table 4.9	Specific Gravities for Cementitious Materials	116
Table 4.10	Specific Gravities and Absorption Capacities for Aggregate Sources	120
Table 5.1	Visual Stability Index (VSI) Rating	133
Table 5.2	J-Ring Passing Ability Rating	136
Table 6.1	Fresh Concrete Properties for Phase I	152
Table 6.2	Fresh Concrete Properties for Phase II	155
Table 6.3	Fresh Concrete Properties for Phase III	157
Table 6.4	Fresh Concrete Properties for ODSC Mixtures	159

Table 6.5	Fresh Concrete Properties for SCC Mixtures	160
Table 6.6	Segregation and Bleeding Results	167
Table 6.7	Passing Ability Results for SCC Mixtures	168
Table 6.8	Fresh Concrete Properties for both Laboratory and Field Conditions ...	185
Table 6.9	Fresh Concrete Properties for Phase V	194
Table 6.10	Tabulated Results of the Effect of VMA on Fresh Concrete Properties..	209

LIST OF FIGURES

Figure 2.1	Upright Slump Cone Method	9
Figure 2.2	Inverted Slump Cone Method	9
Figure 2.3	Visual Stability Index Rating	12
Figure 2.4	L-Box Testing Apparatus	14
Figure 2.5	J-Ring Testing Apparatus	15
Figure 2.6	Segregation Column Testing Apparatus	17
Figure 2.7	Bingham Fluid Model	19
Figure 2.8	Mechanism of Blocking	24
Figure 2.9	Blocking Ratios versus Reinforcement Spacing for Different Size Aggregate	25
Figure 2.10	Strength versus Cement-to-Water Ratio	30
Figure 2.11	Compressive Strength versus Porosity	31
Figure 2.12	Strength versus Gel-to-Space Ratio Based on Tested Mortar Cubes.....	33
Figure 2.13	Average Compressive Strengths of SCC and Conventional Bridge Concretes with w/c of 0.40	34
Figure 2.14	Elastic Modulus versus Sand-to-Aggregate Ratio	38
Figure 2.15	Aggregate Content versus Water-to-Cement Ratio	40
Figure 2.16	Shrinkage Modification Factor for Different Sand-to-Aggregate Ratios	41
Figure 2.17	Shrinkage versus Cement Content	42
Figure 2.18	Drying Shrinkage versus Age (Kim et al. 1998)	43

Figure 2.19	SCC versus Normal Concrete.....	44
Figure 2.20	Drying Shrinkage versus Sand-to-Aggregate Ratio.....	45
Figure 2.21	Coefficient of Permeability versus Capillary Porosity	46
Figure 2.22	Coefficient of Permeability versus Water-to-Cement Ratio	46
Figure 2.23	RCPT Values of SCC and Normal Concrete	48
Figure 3.1	Drilled Shaft Mixture with a Slump of Approximately 6.5 Inches	55
Figure 3.2	Drilled Shaft Mixture with a Slump of 8-9 Inches	56
Figure 3.3	Illustration of Tremie Placement	59
Figure 3.4	Illustration of Entrapped Debris due to the Eruption of Fresh Concrete through Stiff Concrete	60
Figure 3.5	Illustration of Entrapped Debris Seams due to Extraction of the Tremie..	61
Figure 3.6	Example 1 of Shaft Defects due to the Loss of Workability	62
Figure 3.7	Example 2 of Shaft Defects due to the Loss of Workability	62
Figure 3.8	Example 3 of Shaft Defects due to the Loss of Workability	63
Figure 3.9	Example 4 of Shaft Defects due to the Loss of Workability	63
Figure 3.10	Example 5 of Shaft Defects due to the Loss of Workability.....	64
Figure 3.11	Illustration of a Cased Hole	65
Figure 3.12	Necking and Arching due to the Extraction of the Casing when Workability is Lost	66
Figure 3.13	Shaft Defects due to the Extraction of the Casing	67
Figure 3.14	Slump Loss versus Time Relationship	68
Figure 3.15	Slump Loss at 70° F for Two Different Brands of Type I Cement	69
Figure 3.16	Shaft Defects due to the Loss of Workability (left), After Removal of Surface Flaws for Repairs	70
Figure 3.17	Shaft Defects due to the Loss of Workability from Construction Delays..	72

Figure 3.18	Screening of the Concrete due to Heavily Reinforced Rebar Cages	76
Figure 3.19	Elevation Difference between the Inside and Outside of a Rebar Cage due to Screening of the Concrete Flow	77
Figure 3.20	Shaft Defects due to the Screening of the Concrete Flow	77
Figure 3.21	Oval Shaped Column with Figure 8 Rebar Cage	79
Figure 3.22	Shaft Defect due to Double Reinforcement Cages	80
Figure 3.23	Illustration of Bleeding in Freshly Placed Concrete	84
Figure 3.24	Example 1 of Bleed Channels and Surface Streaks due to Bleed Water Traveling along the Casing	84
Figure 3.25	Example 2 of Bleed Channels and Surface Streaks due to Bleed Water Traveling along the Casing	85
Figure 3.26	Shaft Defect due to Bleed Water Traveling along the Casing	86
Figure 4.1	Flow Chart for Phase I	94
Figure 4.2	Flow Chart for Phase II	96
Figure 4.3	Flow Chart for Phase III	100
Figure 4.4	Example of Identification System for Ordinary Drilled Shaft Concrete	102
Figure 4.5	Example of Identification System for SCC Mixtures	102
Figure 4.6	Flow Chart for Phase IV	106
Figure 4.7	Example of Identification System for Phase V	108
Figure 4.8	Flow Chart for Phase V	111
Figure 4.9	Particle Size Analyzer	117
Figure 4.10	Laser Particle Size Analyzer Results	118
Figure 4.11	Raw Material being Delivered from South Carolina	119
Figure 4.12	No. 67 Coarse Aggregate Gradation for South Carolina Material	121
Figure 4.13	No. 789 Coarse Aggregate Gradation for South Carolina Material	121

Figure 4.14	Fine Aggregate Gradation for South Carolina Material	122
Figure 4.15	No. 67 Coarse Aggregate Gradation for Alabama Material	122
Figure 4.16	No. 89 Coarse Aggregate Gradation for Alabama Material	123
Figure 4.17	Fine Aggregate Gradation for Alabama Material	123
Figure 5.1	New Indoor Mixing Facility	127
Figure 5.2	12 ft ³ Concrete Mixer used for this Research	129
Figure 5.3	Testing Equipment for Slump Test	130
Figure 5.4	Testing Equipment for Slump Flow Test	132
Figure 5.5	Visual Stability Index Rating	133
Figure 5.6	Testing Equipment for J-Ring Test	135
Figure 5.7	L-Box Dimensions	137
Figure 5.8	Testing Equipment for L-Box Test	137
Figure 5.9	Testing Equipment for Segregation Column Test	139
Figure 5.10	Testing Equipment for Bleeding Test	142
Figure 5.11	Testing Equipment for Unit Weight and Air Content	143
Figure 5.12	Testing Equipment for Time of Setting	145
Figure 5.13	600 Kip Forney Compression Machine	146
Figure 5.14	Concrete Specimen with Compressometer Attached	148
Figure 5.15	Humboldt Length Comparator, Mold, and Concrete Specimen	149
Figure 5.16	Model 164 Test Set and Prove' It Cells	150
Figure 6.1	Slump Flow vs. Concrete Age for Phase I	153
Figure 6.2	Slump Flow vs. Concrete Age for Phase II	155
Figure 6.3	Penetration Resistance vs. Concrete Age for Phase II	156

Figure 6.4	Slump Flow vs. Concrete Age for Phase III	158
Figure 6.5	Workability of ODSC Mixture (approximately 8.25 inches)	161
Figure 6.6	Workability of SCC Mixture (approximately 20 inch slump flow)	161
Figure 6.7	Slump vs. Concrete Age	163
Figure 6.8	Slump Flow vs. Concrete Age	164
Figure 6.9	Slump vs. Concrete Age for all Concrete Mixtures	164
Figure 6.10	Penetration Resistance vs. Concrete Age	165
Figure 6.11	Compressive Strength vs. Concrete Age for Phase IV	171
Figure 6.12	Modulus of Elasticity vs. Concrete Age for Phase IV	173
Figure 6.13	Predicted vs. Measured Elastic Modulus according to ACI 318 (2002) Equation for Phase IV	174
Figure 6.14	Predicted vs. Measured Elastic Modulus According to ACI 363 (2002) Equation for Phase IV	174
Figure 6.15	Drying Shrinkage vs. Concrete Age	176
Figure 6.16	91-Day Permeability Results	179
Figure 6.17	365-Day Permeability Results	179
Figure 6.18	Attaining Raw Materials from Stock Piles	182
Figure 6.19	Unloading Raw Materials onto Conveyer Belt	183
Figure 6.20	Raw Materials being Delivered to Hopper via Conveyer Belt	183
Figure 6.21	Raw Materials being Mixed by Ready Mix Truck	184
Figure 6.22	Slump Flow vs. Mixing Time under Laboratory and Field Conditions ..	186
Figure 6.23	Temperature Profile Obtained from I-Button	188
Figure 6.24	Penetration Resistance vs. Concrete Age under Laboratory and Field Conditions	188

Figure 6.25	Compressive Strength vs. Concrete Age under Laboratory and Field Conditions	189
Figure 6.26	Modulus of Elasticity vs. Concrete Age under Laboratory and Field Conditions	190
Figure 6.27	Compressive Strength vs. Concrete Age for VMA Mixtures.....	201
Figure 6.28	Modulus of Elasticity vs. Concrete Age for VMA Mixtures	201
Figure 6.29	Compressive Strength vs. Concrete Age for Fly Ash Mixtures.....	202
Figure 6.30	Modulus of Elasticity vs. Concrete Age for Fly Ash Mixtures.....	202
Figure 6.31	Compressive Strength vs. Concrete Age for Silica Fume Mixtures	203
Figure 6.32	Modulus of Elasticity vs. Concrete Age for Silica Fume Mixtures.....	203
Figure 6.33	Compressive Strength vs. Concrete Age for GGBFS Mixtures	204
Figure 6.34	Modulus of Elasticity vs. Concrete Age for GGBFS Mixtures	204
Figure 6.35	Compressive Strength vs. Concrete Age for Micron 3 Mixtures.....	205
Figure 6.36	Modulus of Elasticity vs. Concrete Age for Micron 3 Mixtures	205
Figure 6.37	Compressive Strength vs. Concrete Age for Limestone Mixtures	206
Figure 6.38	Modulus of Elasticity vs. Concrete Age for Limestone Mixtures	206
Figure 6.39	Predicted vs. Measured Elastic Modulus According to ACI 318 (2002) Equation for Phase V	207
Figure 6.40	Predicted vs. Measured Elastic Modulus According to ACI 363 (2002) Equation for Phase V	207
Figure 6.41	Graphical Results of the Effect of VMA on Fresh Concrete Properties .	210
Figure 7.1	Proposed Field Site	215

CHAPTER 1

INTRODUCTION

1.1 STATEMENT OF PROBLEM

In recent years, drilled shaft concrete mixtures are facing increasing demands for fluidity. One of the primary reasons for this increased need for fluidity is the utilization of larger diameter shafts, deeper shafts, and congested rebar cages. The use of larger diameter shafts that are designed for large bending moments and seismic conditions require high amounts of reinforcement to be placed within the shaft. Consequently, the rebar cages have become progressively more congested and resistive to concrete flow. The addition of numerous access tubes for integrity testing has also lead to increased congestion in the rebar cages. These heavily congested rebar cages have lead to increased blockage due to the contact within the aggregates when the concrete is forced through the rebar cage. Even when a concrete mixture has sufficient workability, blockage could occur due to the bridging of the coarse aggregate at the vicinity of the reinforcement bars. In addition, tremie placement of drilled shaft concrete may require prolonged periods for concrete placement, which may result in a loss of concrete workability before the shaft is completed. It has been observed by experienced engineers that this loss of workability has lead to structural defects due to the entrapment of debris within the shaft. These large diameter and deep shafts also call for large amounts of concrete to be placed. Case studies have shown that with these massive concrete pours

large amounts of bleed water can be generated and begins to rise up in the column. The rising bleed water can result in larger interfacial transition zones, loss of bond between the reinforcement and concrete, surface streaking, and vertical bleed channels in the interior of the shaft.

Many state DOT specifications have not kept appropriate workability considerations as a special aspect of drilled shaft concrete to meet these increasing demands for fluidity. For this reason, other viable materials such as self-consolidating concrete (SCC) could be possible solutions for this increased need for fluidity. Although the use of SCC has been largely implemented in the precast/prestressed industry, the potential benefits in drilled shaft construction are enormous. SCC has the potential to address many of the problems associated with drilled shaft construction because of the inherent workability, passing ability, resistance to segregation, and reduced bleeding of this type of concrete. The general requirements for SCC mixtures are as follows:

- Reduced volume of coarse aggregate: as the size and amount of coarse aggregate plays an important role on the passing ability of the concrete mixture.
- Increased volume of paste: the friction between the aggregate controls the spreading and the filling ability of the concrete.
- Increased volume of very fine material: this ensures sufficient workability while reducing the risk of segregation and bleeding.
- High dosage of high-range water reducing admixtures: these provide the necessary fluidity.
- Viscosity modifying admixture (VMA): these admixtures can potentially reduce bleeding and coarse aggregate segregation.

SCC has not currently been used for drilled shaft construction in North America. Some of the potential impediments include the general and overall lack of experience and research with these concrete mixtures for drilled shaft construction. As a result, extensive research must be conducted to generate interest in the construction community and to develop DOT acceptance of the use of SCC in drilled shaft construction, especially when inspection is difficult.

1.2 RESEARCH OBJECTIVES

The primary objectives of this research are to evaluate the use of SCC in drilled shaft construction, identify appropriate testing techniques and characteristics for this specific application, and potential problems or concerns with the use of SCC in drilled shaft construction. A laboratory testing program as well as a later full-scale field study will examine the difference between ordinary drilled shaft concrete and SCC for both fresh and hardened properties. The fresh properties include filling ability, passing ability, segregation resistance, workability over time, bleeding characteristics, and controlled setting, while the hardened properties include the comparison of the compressive strength, elastic modulus, drying shrinkage, and permeability. It is anticipated that this research will lead to additional interest in this topic from state and national transportation agencies. While there is considerable research being directed toward SCC as a material, this research will be primarily focused upon the application of this technology to the drilled shaft industry.

1.3 RESEARCH SCOPE

This research project was subject to a literature review of published material related to SCC. Chapter 2 of this thesis contains information regarding the factors that influence both the fresh and hardened concrete properties of SCC. These fresh properties primarily consist of the filling ability, passing ability, and segregation resistance, while the hardened concrete properties include compressive strength, modulus of elasticity, drying shrinkage, and permeability. Chapter 3 will address several aspects of design and construction that are essential for high-quality drilled shaft concrete and problems that are encountered in drilled shaft construction that leads to poor quality drilled shaft foundations. Selected examples of more common problems associated with drilled shaft concrete are cited in this chapter so that these problems can be understood.

Chapters 4 and 5 present the laboratory testing program, raw materials, and testing procedures for both fresh and hardened concrete properties utilized for this research project. Chapter 6 provides an in-depth discussion and analysis of the laboratory testing program as well as providing for a comparison between ordinary drilled shaft concrete and SCC for fresh and hardened concrete properties.

Chapter 7 presents a proposed field study to be conducted in South Carolina. This proposed field study will examine the difference between ordinary drilled shaft concrete and SCC for both fresh and hardened properties under simulated field conditions. Finally, Chapter 8 offers conclusions and recommendations based on the results and analysis provided in Chapter 6.

CHAPTER 2

LITERATURE REVIEW OF SELF-CONSOLIDATING CONCRETE

A review of literature pertaining to relevant research topics associated with self-consolidating concrete (SCC) is presented in this chapter. The topics covered include a background of SCC, SCC testing procedures, fresh concrete properties of SCC, and hardened concrete properties of SCC.

2.1 INTRODUCTION

In the early 1980s, durability issues related to concrete structures were a major concern and topic of interest in Japan. The gradual reduction in high-quality construction practice and concrete placement by unskilled labor resulted in deficient concrete structures (Okamura and Ouchi 1999). In an effort to produce durable concrete structures independent of the quality of construction practice, Professor Hajime Okamura at the University of Tokyo developed self-consolidating concrete that would be able to consolidate under its own weight without the need for external vibration.

Self-consolidating concrete is able to fill formwork, encapsulate reinforcement bars, and consolidate under its own weight. At the same time it is cohesive enough to maintain its homogeneity without segregation or bleeding. This makes SCC useful in applications where placing concrete is difficult, such as heavily-reinforced concrete structures or where formwork is complex. Rilem Report 23 from Technical Committee 174-SCC (Skarendahl 2000) suggests that three main functional requirements of SCC are as follows:

- 1. Filling Ability:** The ability of the concrete to completely fill formwork and encapsulate reinforcement without the use of external vibration.
- 2. Passing Ability:** The ability of the concrete to pass through restrictive sections of formwork and tightly spaced reinforcement bars without blockage due to interlocking of aggregate.
- 3. Segregation Resistance:** The ability of the concrete to keep particles in a homogenous suspension throughout mixing, transportation, and placement.

The objective with the development of SCC is to overcome problems associated with conventional concrete that include improper consolidation, inability to pass and encapsulate reinforcement bars, and the incapability to adequately fill formwork.

However, the acceptance and application of SCC in North America requires an orderly and conscious approach because suppliers, contractors, engineers, and architects are concerned with different aspects of the concrete's performance (Khayat and Daczko 2003). In addition, this approach is imperative because SCC is being developed by multiple agencies with different approaches, and there is a lack of standardized tests to assess the quality of SCC. This has led well-known organizations, such as ASTM and RILEM, to address this issue and develop standardized testing procedures.

As standardized tests and well-defined mixture proportioning become available, the familiarity and use among suppliers, contractors, engineers, and architects will increase with confidence allowing the user to quantify the benefits of SCC. Some of these benefits include reduced labor cost, superior finish, reduced need for surface patching, no vibration, and reduction in noise pollution.

2.2 SCC TESTING PROCEDURES

The **Filling Ability**, **Passing Ability**, and **Segregation Resistance** of a SCC mixture must be evaluated through appropriate test methods to determine its quality. These properties are not independent from each other, but interrelated in some aspect. For example, the deformation capacity or filling ability is in part related to the viscosity, where the viscosity is strongly related to the segregation resistance. For that reason, some of the tests developed for SCC evaluate one or more of the fresh properties. Numerous tests have been developed for the evaluation of the fresh properties of SCC; however, a review of test methods that are relevant to this research and drilled shaft applications is presented in this section. The tests covered include the slump flow test, L-Box, J-Ring, and segregation column. The information presented in this section is offered only as a guide until standardized tests are developed for SCC testing.

2.2.1 Slump Flow Test

The assessment of SCC to flow involves the evaluation of the filling ability or deformation capacity. The slump flow test is one of the most common and popular test to evaluate the deformation capacity of SCC because the procedure and apparatus are relatively simple (Takada and Tangtermsirikul 2000). The slump flow test is used to assess the filling ability of SCC in the absence of obstructions. The rate of deformability can be assessed by determining the T_{50} time while the segregation resistance can to a certain degree be visually inspected. The T_{50} time corresponds to the time that it takes for the concrete to flow 20 inches during the slump flow test.

The slump flow test consists of filling an ordinary slump cone with SCC without any rodding. The cone is then lifted and the mean diameter is measured after the

concrete has ceased flowing. The apparatus for the slump flow test can be seen in Figure 2.1. The PCI (2003) states that it can be argued that because the slump flow test only assesses the free flow, unrestricted by boundaries, it is not representative of what happens in concrete construction. However, the slump flow test is useful in evaluating the consistency of SCC as delivered to the job site, and it gives some indication of segregation resistance by visual observation (PCI 2003).

The slump flow test can be performed in the upright or inverted position, and the method utilized should be used consistently without switching from one to the other. The upright and inverted methods can be seen in Figures 2.1 and 2.2, respectively. The inverted method allows the slump cone to be easily filled by pouring the sample into a larger opening, which reduces the amount of spillage. Furthermore, the inverted method does not require a person to stand on the slump flow table because the weight of the concrete holds the cone downward onto the table. Ramsburg (2003) reports that it is possible that only one technician can conduct the slump flow by either method, though most users state that two technicians are needed for the upright position. However, one may argue that the two methods will produce different slump flow values. A recent study conducted by Oldcastle Inc. evaluated the difference in slump flow values between the two methods using three different mix designs with three different levels of performance (Ramsburg 2003). The three different levels of performance were slump flows less than 25 inches, slump flows over 25 inches, and slump flows over 25 inches with noted segregation and bleeding. The results indicate that there is only a minimal difference in the slump flow between the two methods.

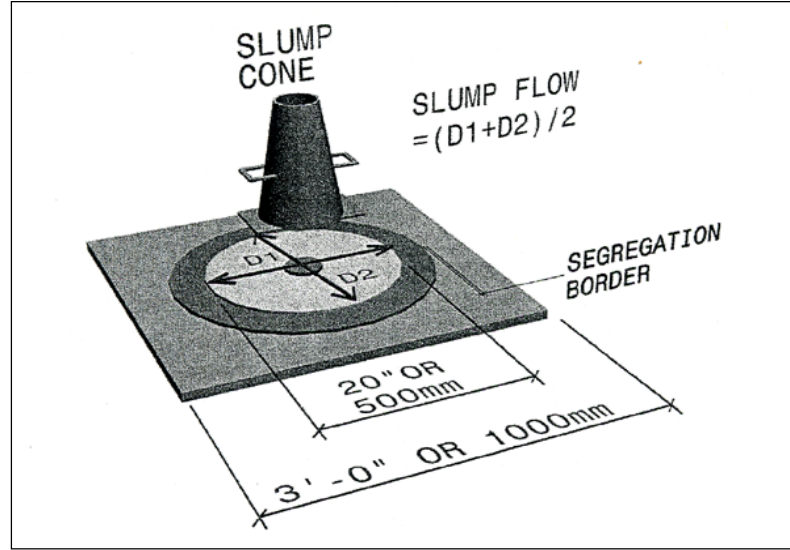


Figure 2.1 – Upright Slump Cone Method (PCI 2003)

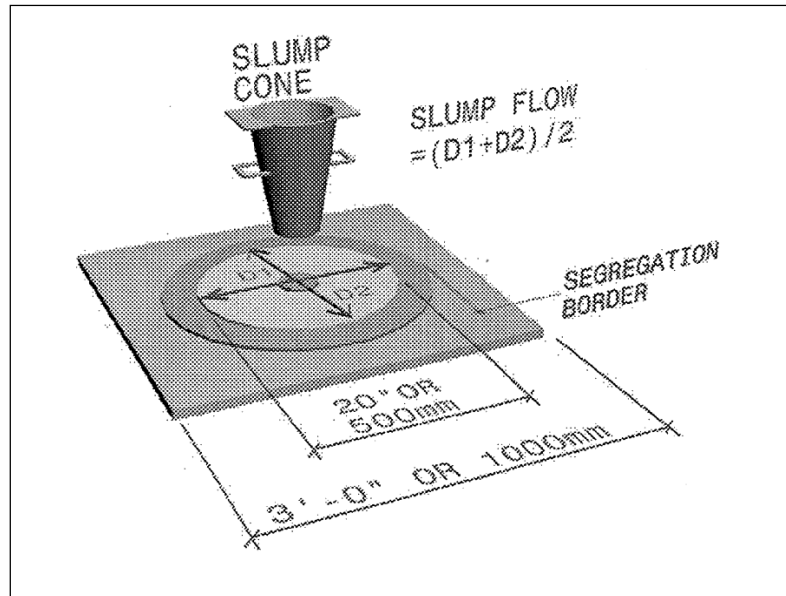


Figure 2.2 – Inverted Slump Cone Method (PCI 2003)

As previously reported, the T_{50} time corresponds to the time that it takes for the concrete to flow 20 inches during the slump flow test. The T_{50} time is often used to evaluate the viscosity or rate of deformability of SCC. However, Takada and Tangtermsirikul (2000) reported that the T_{50} time is not a direct measure of the viscosity of the mix independent of the slump flow value. For instance, a larger slump flow value will produce a lower T_{50} time when the viscosity of the mix is constant. The T_{50} time can be used to evaluate the difference in viscosity of mixtures only when the slump flow value is constant (Takada and Tangtermsirikul 2000). Additionally, the T_{50} time can be used as an indication of production uniformity of a given SCC mixture. The PCI (2003) states that the T_{50} time should not be used as a factor to reject a batch of SCC, but rather as a quality control test. However, recent provisions provided by the FDOT state that the T_{50} time should be between 2 and 7 seconds for acceptance purposes (Mujtaba 2004).

Ramsburg (2003) reports that the T_{50} times are somewhat arbitrary due to the difficulty of starting and stopping a clock while conducting the slump flow test. This issue is more of a concern as the T_{50} times become lower, where the possible intervals are less than 1.5 seconds. Furthermore, the tests conducted by Oldcastle Inc. show an increase in T_{50} times when performing the inverted slump flow test (Ramsburg 2003). It was further determined that as the slump values increased, the difference in T_{50} times were found to be less obvious between the two methods. Moreover, the inverted method could possibly improve the accuracy of the T_{50} times when the intervals are only a few seconds; thus, a small difference in viscosity could be more noticeable with the inverted method (Ramsburg 2003).

One of the most critical requirements for SCC is that it must not segregate during or after placement. The slump flow test provides an indication of the segregation resistance by visual observation. Therefore, the visual stability index (VSI) was developed to determine the ability of a SCC mixture to resist segregation. The VSI procedure is to assign a numerical rating from 0 to 3, in increments of 0.5, based on the homogeneity of the mixture after the slump flow test has been conducted. To differentiate the textural properties of SCC, it should be ranked according to Table 2.1 and Figure 2.3.

The basis for the VSI is that when the segregation resistance is not sufficient, the coarse aggregate will tend to stay in the center of the slump flow patty and mortar at the SCC border (Takada and Tangtermsirikul 2000, and PCI 2003). In the case of minor segregation, a border of mortar without coarse aggregate can occur at the edge of the slump flow patty (PCI 2003). Since the slump flow patty has no significant depth through which settlement of aggregate can occur, the visual inspection of SCC in the wheelbarrow or mixer should be part of the process in determining the VSI rating (PCI 2003). In fact, Bonen and Shah (2004) state that visual evaluation of segregation from the slump flow patty is an inadequate measure for predicting segregation resistance in the static state. Khayat et al. (2004) reports that the VSI rating of the slump flow patty is considered part of the **dynamic** stability given the fact the concrete can exhibit some non-uniform texture following some mixing and transport; whereas, the VSI can be considered as a **static** stability index when it is observed in the wheelbarrow or mixer following some period of rest time.

Table 2.1 – Visual Stability Index (VSI) Rating (Khayat et al. 2004)

Rating	Criteria
0	No evidence of segregation in slump flow patty, mixer drum, or wheelbarrow
1	No mortar halo in slump flow patty, but some slight bleeding on surface of concrete in mixer drum and/or wheelbarrow
2	Slight mortar halo (<10mm) in slump flow patty and noticeable layer of mortar on surface of testing concrete in mixer drum and wheelbarrow
3	Clearly segregating by evidence of large mortar halo (>10mm) and thick layer of mortar and/or bleed water on surface of testing concrete in mixer drum or wheelbarrow

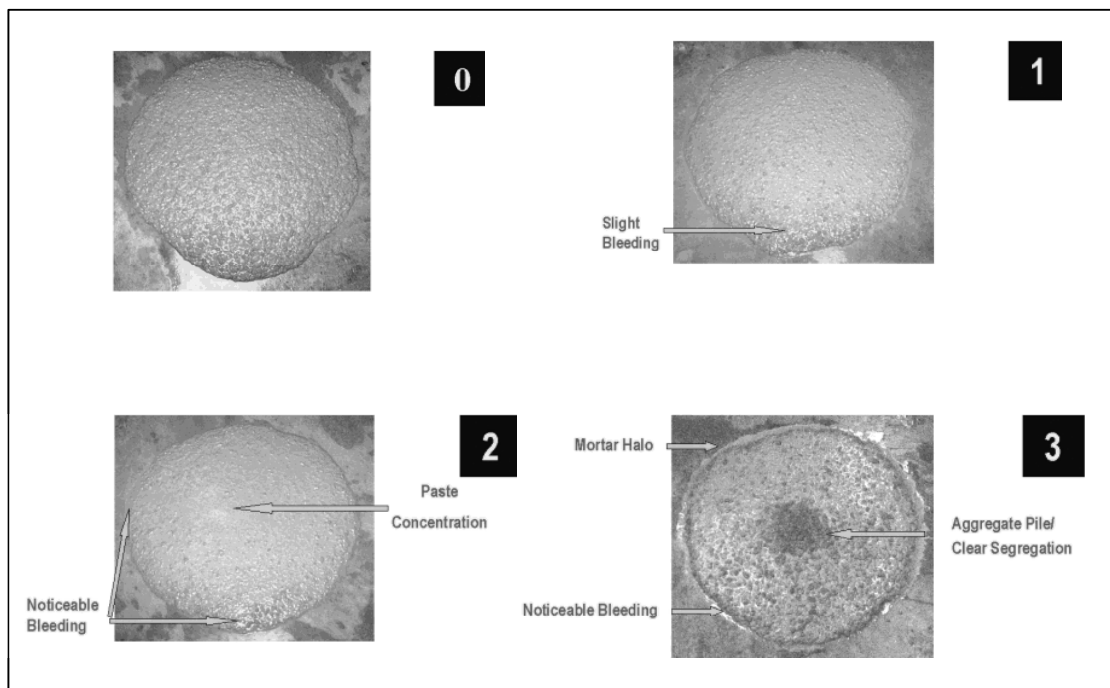


Figure 2.3 - Visual Stability Index Rating (Degussa Construction Chemicals 2004)

2.2.2 L- Box Test

The L-Box is used to assess the passing ability of a SCC mixture. This test is suitable for laboratory and perhaps for site purposes (PCI 2003). The apparatus consist of a rectangular-section box in shape of an “L” with a vertical and horizontal section separated by a removable gate as shown in Figure 2.4. The L-Box is equipped with reinforcement bars separated by narrow openings that are designed to evaluate the passing ability of a SCC mixture. The reinforcement bars can be different diameters and spaced at different intervals (PCI 2003). The PCI (2003) suggests that three times the maximum aggregate size may be appropriate for the reinforcement spacing.

The L-Box test is conducted by filling the vertical section of the L-Box with SCC, and then the removable gate is lifted to allow the SCC to flow into the horizontal section (PCI 2003). After the flow has ceased, the height of the SCC at the end of the horizontal section (H_2) and the remaining SCC in the vertical section (H_1) is measured and expressed as a blocking ratio. This blocking ratio (H_2/H_1) is an indication of the passing ability of a SCC mixture. The closer the blocking ratio is to 1, the better the passing ability of the SCC mixture. Petersson (2000) reports that according to Swedish experience, a blocking ratio of 0.80- 0.85 is an acceptable range of values.

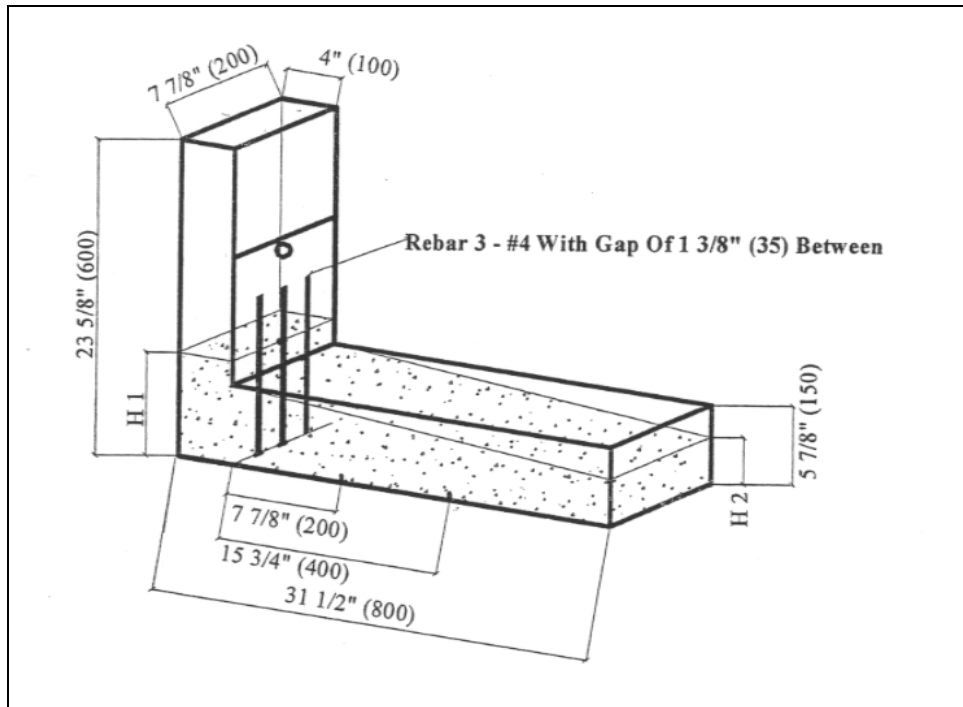


Figure 2.4 – L-Box Testing Apparatus (PCI 2003)

2.2.3 J-Ring Test

The J-Ring test is used to determine the passing ability of a SCC mixture. This test is suitable for laboratory and perhaps for site purposes (PCI 2003). The equipment consists of an open steel circular ring, drilled vertically to accept sections of reinforcement bars as shown in Figure 2.5. The rods can be different diameters and spaced at different intervals (PCI 2003). The PCI (2003) suggests that three times the maximum size aggregate may be appropriate for the reinforcement spacing. The spacing of the rods at different intervals will impose a more or less severe test of the passing ability depending on the application.

The J-Ring test is used in conjunction with the slump flow test. The combination of the two tests will allow the assessment of the passing ability of the SCC mix design.

This test is performed in the same manner as the slump flow test with the addition of the J-Ring. The difference between the slump flow and the J-Ring flow is compared, and then a passing ability rating is assigned according to Table 2.2. The larger the difference between the slump flow and the J-Ring flow indicates less passing ability. Recent provisions provided by the FDOT state that the difference between the slump flow and the J-Ring flow should be no more than 2 inches (Mujtaba 2004).

Table 2.2 - J-Ring Passing Ability Rating (ASTM J-Ring Draft 2004)

Difference between Slump Flow and J-Ring Flow	Passing Ability Rating	Remarks
$0 \leq X \leq 1$ inch	0	No visible blocking
$1 < X \leq 2$ inches	1	Minimal to noticeable blocking
$X > 2$ inches	2	Noticeable to extreme blocking

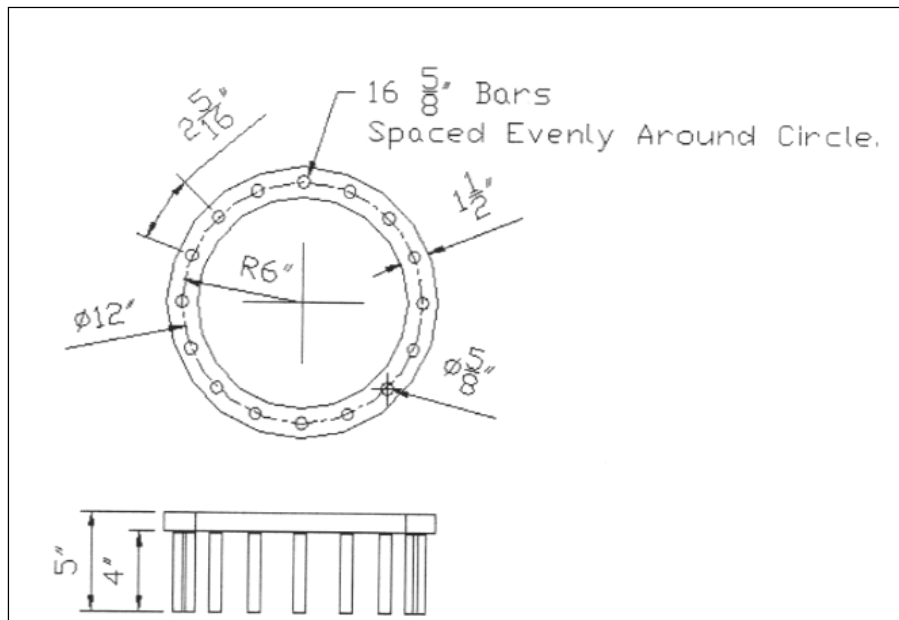


Figure 2.5 - J-Ring Testing Apparatus (ASTM J-Ring Draft 2004)

2.2.4 Segregation Column Test

The segregation column test is used to determine the stability and segregation resistance of a SCC mixture. This test can be used for both laboratory and perhaps site purposes (ASTM Segregation Column Draft 2004). The equipment consists of an 8-inch diameter by 26-inch tall schedule 40 PVC pipe. The PVC pipe is separated into 4 equal sections each measuring 6.5-inches in height. A collector plate measuring 20-in. x 20-in. is used to collect the concrete from the different sections of the column. The segregation column and the collector plate can be seen in Figure 2.6.

The segregation column test is conducted by placing a sample of concrete in the cylinder mold in one lift without any means of mechanical vibration. After the concrete is allowed to sit for 15 minutes, the concrete column is separated into four equal sections using the collector plate. The concrete from the top and bottom section is wet-washed through a No. 4 sieve leaving the coarse aggregate on the sieve. The mass of aggregate from these sections of the column is obtained, and a segregation index is determined using Equation 2.1.

$$SI = \frac{(CA_B - CA_T)}{CA_{BM}} \quad \text{Eq. 2.1}$$

In Equation 2.1, SI is the segregation index, CA_T is the mass of coarse aggregate in the top section, CA_B is the mass of coarse aggregate in the bottom section, and CA_{BM} is the mass coarse aggregate per section of the column according to Equation 2.2.

$$CA_{BM} = 0.007 * CA_M [0.0052 * CA_M] \quad \text{Eq. 2.2}$$

In Equation 2.2, CA_M is the mass of coarse aggregate in 1 yd³ of concrete.

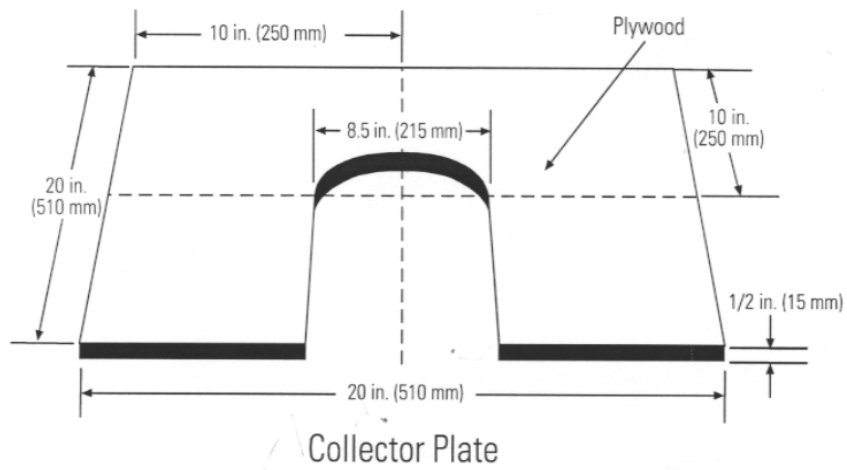
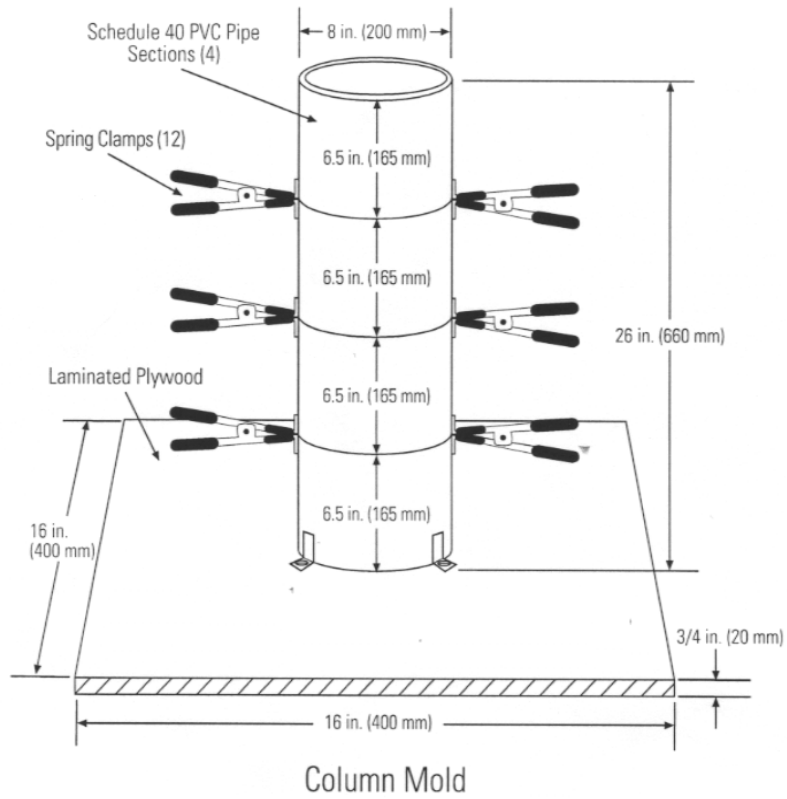


Figure 2.6 - Segregation Column Testing Apparatus (ASTM Segregation Column Draft 2004)

2.3 FRESH CONCRETE PROPERTIES

SCC is characterized by its filling ability, passing ability, and segregation resistance. SCC has to have a low yield stress value to ensure high flowability, small aggregate particles to prevent blockage, and adequate viscosity to prevent segregation. Thus, these characteristics must be discussed in further detail to allow the user to develop a well-designed SCC mixture.

2.3.1 Rheology

Before discussing the various ways to modify SCC characteristics, it is helpful to discuss a few basic principles of rheology. Rheology can be described as the study of deformation and flow of matter under stress (Mindess et al. 2003). Understanding and knowledge of rheology behavior has been essential in the development of self-consolidating concrete and influences the performance of the fresh concrete properties. The rheology of concrete, paste, or mortar may be characterized by its yield stress and plastic viscosity. The rheology of fresh concrete, including self-consolidating concrete, is most often defined by the Bingham Fluid Model using Equation 2.3 (Mindess et al. 2003).

$$\tau = \tau_0 + \mu * \gamma \quad \text{Eq. 2.3}$$

In Equation 2.3, τ is the shear stress in psi, τ_0 is the yield stress in psi, μ is the plastic viscosity in psi · seconds, and γ is the shear strain in 1/seconds. Figure 2.7 shows that the Bingham Fluid Model requires a yield stress to obtain a strain that is followed by increasing shear stress with increasing shear strain (Khayat and Tangtermsirikul 2000). Khayat and Tangtermsirikul (2000) report that the target rheological properties for SCC are a low yield stress value together with an adequate plastic viscosity.

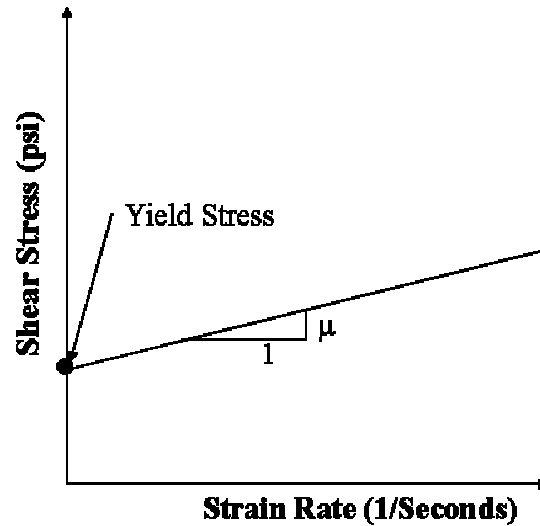


Figure 2.7 - Bingham Fluid Model

A number of rheometers, e.g. BML viscometer and BTRHEOM rheometer, have been developed to measure the true rheological properties of fresh concrete. Rheometers provide two parameters, namely the initial yield stress value and the plastic viscosity, to characterize the fresh properties. These rheometers are useful in evaluating what the effects of different materials, such as cements, fillers, aggregates, mineral admixtures, and chemical admixtures have on the yield stress and plastic viscosity. According to Emborg (1999), rheometers are considered to be the most accurate way to describe the real behavior of fresh concrete. However, rheometers are based on different principles, and the results from different rheometers can not be easily compared. While it is likely that the use of rheology tests and rheometers will increase in the future, rheometers are expensive to purchase and existing tests are primarily used for initial mixture proportioning, testing, and research efforts.

2.3.2 Filling Ability

Self-consolidating concrete must be able to fill formwork and encapsulate reinforcement without the use of external vibration. The high deformation capacity of SCC is related to the yield stress; thus, the yield stress must be reduced in order to ensure that SCC can flow around obstacles and achieve good filling ability. The deformation capacity can be increased by the reduction of interparticle friction between the solid particles, which include the paste, coarse aggregate, and fine aggregate (Khayat and Tangtermsirikul 2000). The interparticle friction between the paste particles requires the dispersion of fine material by superplasticizers. Khayat and Tangtermsirikul (2000) state that unlike water that reduces both the yield stress and viscosity, superplasticizers reduce the yield stress and cause a limited decrease in viscosity. As a result, the addition of superplasticizers can provide highly flowable concrete without a significant reduction in cohesiveness. In order to reduce interparticle friction due to aggregate-aggregate contact, Khayat and Tangtermsirikul (2000) recommend that the interparticle distance between the aggregate be increased. This is achieved by reducing the total aggregate content and increasing the paste content. Thus, the following actions should be taken to achieve adequate filling ability (Khayat and Tangtermsirikul 2000):

1. Increase the deformability of the paste

- Balanced water-to-cementitious materials ratio (Balanced so that adequate deformability and deformation velocity can be achieved)
- Superplasticizers

2. Reduced interparticle friction

- Low coarse aggregate volume
- Higher paste contents

Although different superplasticizers are available in the market today, almost all new and innovative superplasticizers are polycarboxylate based mixtures (Bonen and Shah 2004). It must be noted that the following discussion is based on the work of Bury and Christensen (2003). These polycarboxylate based superplasticizers are characterized by their strong dispersing action, controlled slump retention, enhanced concrete stability, enhanced pumping ability, and enhanced finishing ability. These superplasticizers function by imparting a negative charge on the cement particles that cause them to repel from one another. Traditional superplasticizers also function in this manner, but the new polycarboxylate based superplasticizers have side chains with varying lengths that aid in keeping the cement particles apart allowing water to surround more surface area of the cement particle (steric hindrance).

The effectiveness of superplasticizers last only as long as there is sufficient molecules available to cover the surface area of the cement particles. Therefore, it is likely that with time and prolonged mixing the effectiveness of the superplasticizers will become inadequate and the workability of the mix will be lost. Repeated addition of superplasticizers may be beneficial from the standpoint of workability; however, it may increase bleeding, segregation, and change the amount of entrained air (Neville 1996). Neville (1996) goes on to suggest that the workability regained from the re-dosage may decrease at a faster rate. Therefore, the re-dosage should be applied immediately prior to placement according to the recommendations of the admixture supplier.

Bonen and Shah (2004) state that the use of fine material, such as silica fume, will increase the yield stress because of greater water absorbance. Thus, it would be expected that the superplasticizer dosage should be increased to obtain the same slump flow.

Ferraris et al. (2001) reported that with a constant amount of water and cementitious material, the addition of 8% and 12% silica fume increased the superplasticizer dosage by 30% and 50% over the control mix. In fact, it is usually reported that if the volume concentration of solids is held constant, the addition of a fine material will decrease the workability (Ferraris et al. 2001). The most common reason for this reduction in workability is due to increased surface area of the fine material, which will increase the superplasticizer demand for the same water content. However, it is reported in some cases that the addition of fine material can decrease the water demand. Ferraris et al. (2001) states that the reduction of water demand for fine material, especially fly ash, is due to spherical particles that easily move past each other reducing the interparticle friction.

The aggregate shape also influences the filling ability to a certain degree. It is reported that flat and elongated particles will lead to a decrease in the workability (Hodgson 2003). This is due to the fact that angular aggregate will have more mechanical interlocking and will need more work to overcome interparticle friction. For example, Petersson (1999) states that when crushed sand is used, the fluidity is decreased for the same amount of superplasticizer. Conversely, rounded aggregates will act like “ball bearings” allowing the particles to easily move past each other, which will increase the workability for a constant paste and water content. It is generally considered that rounded and smaller aggregate particles will increase the filling ability of concrete.

2.3.3 Passing Ability

The level of passing ability of SCC is a function of the stability, coarse aggregate content, coarse aggregate size, and reinforcement spacing. SCC with excellent deformability but with insufficient cohesiveness will lead to local aggregate segregation between the paste and coarse aggregate at the vicinity of the reinforcement that could lead to severe blockage (Khayat et al. 2004). This will not only lead to decreased passing ability, but it will also lead to an increase in the concentration of coarse aggregate at the reinforcement. The passing ability is also affected when the coarse aggregate size is large and/or the coarse aggregate content is high. This mechanism of blocking can be explained by the two dimensional model shown in Figure 2.8 (Khayat and Tangtermsirikul 2000). Figure 2.8 illustrates that the aggregate particles around an opening must change their path of travel to properly pass through the reinforcement. As a result, aggregate particles may collide at the reinforcement opening. This aggregate interaction may cause the aggregate to form a stable arch at the vicinity of the reinforcement opening (Khayat and Tangtermsirikul 2000). Therefore, to achieve suitable passing ability the following steps should be considered (Khayat and Tangtermsirikul 2000):

1. Enhance the cohesiveness to reduce segregation of aggregate

- Low water-to-cementitious materials ratio
- Viscosity modifying admixture

2. Compatible clear spacing and aggregate characteristics

- Low coarse aggregate contents
- Smaller maximum aggregate size

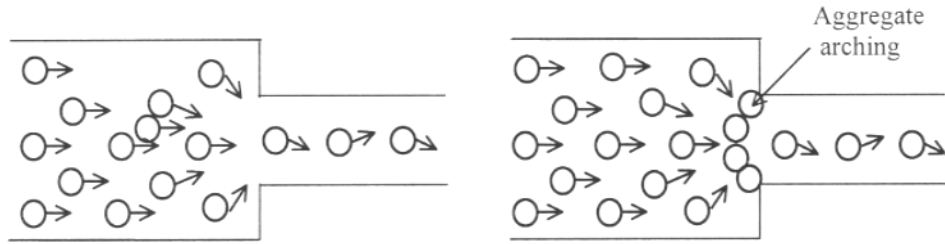


Figure 2.8 - Mechanism of Blocking (Khayat and Tangtermsirikul 2000)

Khayat et al. (2004) conducted studies on the passing ability by evaluating the dynamic stability of SCC using the L-Box and J-Ring apparatus. It was reported that SCC mixtures prepared with 843 lb/yd³ of cement with relatively low viscosity exhibited greater passing ability than SCC mixtures prepared with 650 lb/yd³ of cement. Khayat et al. (2004) reported that the concrete mixtures prepared with 650 lb/yd³ contained more coarse aggregate that increased the risk of collision and interaction among solid particles, which lead to a reduced ability to flow between the reinforcement bars. The greater tendency of aggregate blockage resulted in lower passing ability in both the J-Ring and L-Box tests. Studies conducted by Kim et al. (1998) also indicate that the passing ability was increased with decreasing coarse aggregate content. The results further indicate that SCC mixtures prepared with volume ratios of coarse aggregate-to-concrete of 0.27 and 0.31 demonstrated a higher passing ability than volume ratios of 0.35 and 0.39 at a constant water-to-binder ratio.

Studies conducted at the Swedish Cement and Concrete Institute investigated the blocking in the L-Box apparatus using different maximum size aggregates and reinforcement spacing (Pettersson 1999). The paste content in the mixes remained constant with slump flow values ranging from 25.5 to 28.5 inches. The results in Figure

2.9 indicate that as the reinforcement spacing increases relative to the maximum aggregate size the passing ability is also increased. Furthermore, closer examination of Figure 2.9 reveals that for the same reinforcement spacing the use of smaller aggregates produced higher blocking ratios. Thus, it can be concluded that the maximum size aggregate and reinforcement spacing has an effect on the passing ability of SCC.

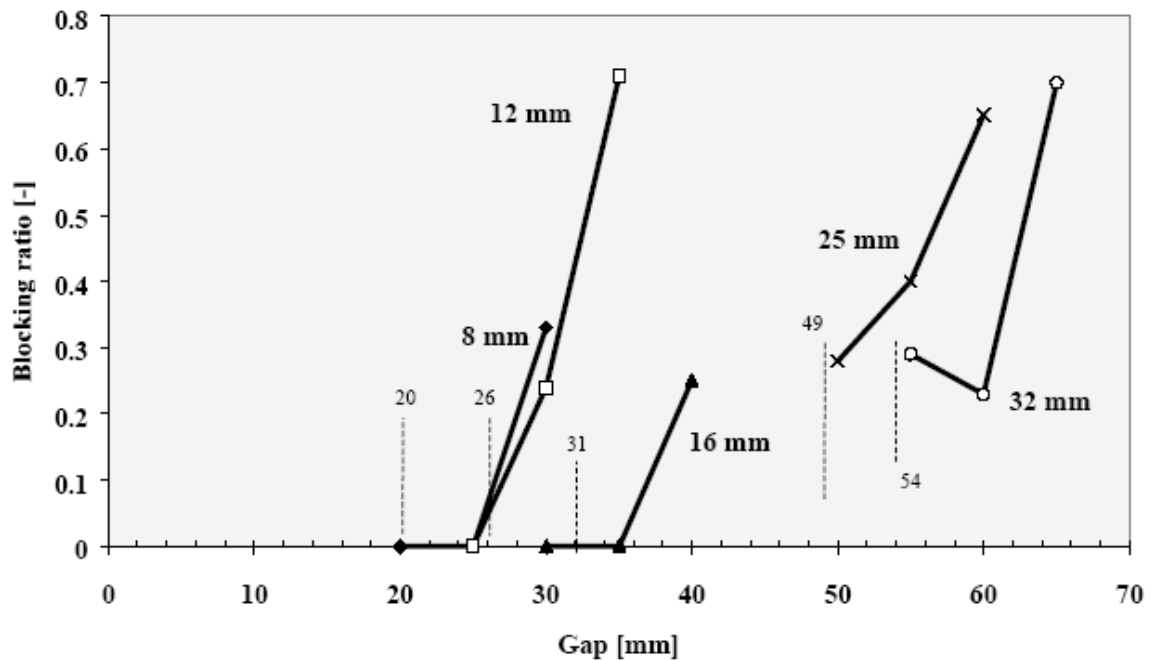


Figure 2.9 - Blocking Ratios versus Reinforcement Spacing for Different Size Aggregate (Pettersson 1999)

2.3.4 Segregation Resistance

One of the most important requirements of SCC is that it must not segregate during or after placement. SCC is much more prone to segregation than normal concrete due to the sharp reduction in viscosity caused by the high dosages of superplasticizers. Thus, it is essential that SCC have a high resistance to segregation so that there is

homogenous distribution of materials in the hardened concrete. Khayat and Tangtermsirikul (2000) report that SCC should not show signs of segregation in static or dynamic conditions, which include bleeding of water, paste and aggregate segregation, and non-uniformity in air pore size distribution. Thus, the following steps should be considered to produce sufficient segregation resistance (Khayat and Tangtermsirikul 2000):

1. Reduce the segregation of solid particles

- Reduced maximum size aggregate
- Low water-to-cementitious materials ratio
- Viscosity modifying admixture

2. Minimize bleeding due to free water

- Low water content
- Low water-to-cementitious materials ratio
- Powders with high surface area
- Viscosity modifying admixture

Segregation of aggregate is related to a number of variables that consist of the particle size, particle specific gravity, and the proportions of the mixture. Bonen and Shah (2004) report that the use of larger coarse aggregates will settle much faster than smaller coarse aggregates when the density and viscosity of the suspension is held constant. Additionally, gradation is also an important factor in determining the proper coarse aggregate, especially where reinforcement is highly congested and/or the formwork has small dimensions. Hodgson (2003) reports that a gap-graded coarse aggregate promotes a greater degree of segregation than well-graded coarse aggregate. Thus, the coarse aggregate chosen for SCC is typically round in shape, well-graded, and smaller in maximum size than that used for conventional concrete.

Another method to increase the segregation resistance besides reduction in aggregate size is to increase the cohesiveness of the mixture. This is typically done by one of the three methods listed below. All three methods use superplasticizers to increase the fluidity of the mixture, but the difference between them is the method used to prevent the segregation (Hodgson 2003).

1. Powder method

2. Viscosity modifying admixture method, “VMA” method

3. Combination method

The **powder method** utilizes an increase in the volume of fines and low water content to reduce the amount of free water. Free water is defined as water that is not adhered to the solid particles and move independently from the solids in a mixture. Furthermore, Khayat and Tangtermsirikul (2000) state that it is essential to reduce the amount of free water in the mixture because an increase in free water content will decrease the viscosity of a SCC mixture. The most common methods for reducing the amount of free water is to use powder materials with a high surface area, use a low water-to-binder ratio, or both. For example, for a constant water content, the addition of high surface area material can absorb a greater amount of free water compared to cement particles. Thus, the plastic viscosity of the mix is increased due to greater water absorbance. Furthermore, the reduction of the water-to-binder ratio will increase the phase-to-phase cohesion that will increase the segregation resistance. Khayat et al. (1999) states that fine powder includes cement and supplementary cementitious material that is combined to enhance grain-size distribution, packing density, and reduced interparticle friction to lower the water demand for a necessary viscosity.

The **VMA method** utilizes lower cement contents, a superplasticizer, and a viscosity modifying admixture (VMA). The addition of a VMA may increase the viscosity of a mix to the extent that the water-to-cementitious ratio need not be increased (Bonen and Shah 2004). VMAs can provide adequate stability, reduce bleeding, and segregation resistance over a wider range of fluidity. There are two basic types of VMAs that are available in the market, and each VMA is based on the mechanism in which they function (Degussa Construction Chemicals 2004):

1. **Thickening Type VMA**- This VMA functions by thickening the concrete, making it cohesive without significantly affecting the fluidity. By increasing the viscosity of the mixture, the VMA makes the mixture more stable and less prone to segregation (Degussa Construction Chemicals 2004). These are typically polyethylene glycol (PEG) based VMAs.
2. **Binding Type VMA**- This VMA functions by binding the water within the concrete mixture. This VMA not only increases the viscosity of the mixture, but it also reduces bleeding. The binding type VMA is more potent in modifying the viscosity of the mixture than the thickening type (Degussa Construction Chemicals 2004). Welan Gum is an example of this type of VMA.

Bury and Christensen (2003) state that the use of a VMA also increases the number of applications for SCC because more mixtures can be proportioned for a wider range of applications. For example, a VMA can be used with mixtures made with gap-graded materials. In fact, Berke et al. (2003) suggests that when poorly graded material and low powder contents are used, the use of a VMA can prove invaluable. In addition, because moisture contents in fine aggregate can change throughout daily operation, the use of a

VMA has been proven to be very valuable in overcoming deficiencies due to uncontrolled moisture (Bury and Christensen 2003).

The **combination approach** utilizes a VMA with limited water content. The VMA in this method primarily is used to reduce the variability of the SCC that can arise from uncontrolled moisture and placement conditions. The VMA also controls bleeding and renders the concrete more robust, while the low water content provides the necessary viscosity (Khayat et al. 1999).

2.4 HARDENED CONCRETE PROPERTIES

The hardened properties of concrete are often the most valued by design and quality control engineers. It has become evident that SCC can have a large variation in mechanical properties due to the different formulations used. Despite these variations, literature has shown that the mechanical properties of well-designed SCC are comparable or better than the corresponding properties of conventional concrete (Bonen and Shah 2004). Although many mechanical properties can be evaluated and compared, only the mechanical properties that are relevant to this research will be discussed in this section.

2.4.1 Compressive Strength

The property that is most often specified for concrete design and quality control is the compressive strength. The testing of the compressive strength is relatively easy to perform in the laboratory, and the compressive strength is universally accepted as a general index of concrete strength. There are many determining factors that influence the

compressive strength of concrete; however, the compressive strength is best described by the water-to-cementitious ratio and the porosity relationship.

When fully compacted, the concrete strength is taken to be inversely proportional to the water-to-cementitious ratio. In 1919, Duff Abrams established the following relationship between the water-to-cementitious ratio and the compressive strength (Neville 1996).

$$f_c = \frac{K_1}{K_2^{w/c}} \quad \text{Eq. 2.4}$$

In Equation 2.4, f_c is the compressive strength, w/c is the water-to-cementitious ratio, and K_1 and K_2 are empirical constants. However, at water-to-cementitious ratios less than 0.38 the maximum possible hydration of the cement is less than 100%. Therefore, the slope of strength gain rate is slowed as the water-to-cementitious ratio is reduced as shown in Figure 2.10.

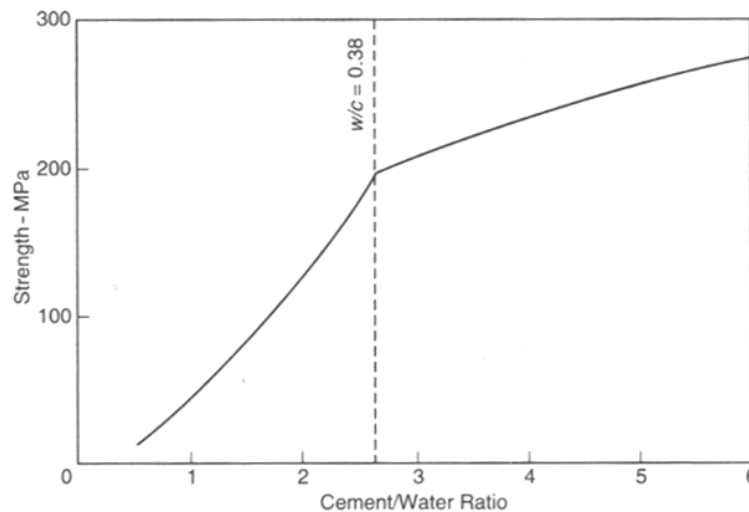


Figure 2.10 - Strength versus Cement-to-Water Ratio (Neville 1996)

The influence of the water-to-cementitious ratio on compressive strength is not truly a constitutive law because the water-to-cementitious ratio rule does not include all factors that influence the compressive strength (Neville 1996). Neville (1996) suggests that it may be more appropriate to relate the compressive strength of concrete to the concentration of solid products of hydration of cement in the space available for these products.

The porosity relationship can be considered one of the most important factors in cement based material because it affects both the cement paste matrix and the interfacial transition zone (ITZ). In general, there exist a relationship between the porosity and the strength of solids that can be described by Equation 2.5 (Neville 1996).

$$f_c = f_{c,0} (1 - p)^n \quad \text{Eq. 2.5}$$

In Equation 2.5, f_c is the strength of the material, $f_{c,0}$ is the strength at zero porosity, n is a coefficient, and p is the porosity. The coefficient n depends on factors that include the cement composition, paste age, and temperature. This relationship between porosity and compressive strength can be seen in Figure 2.11.

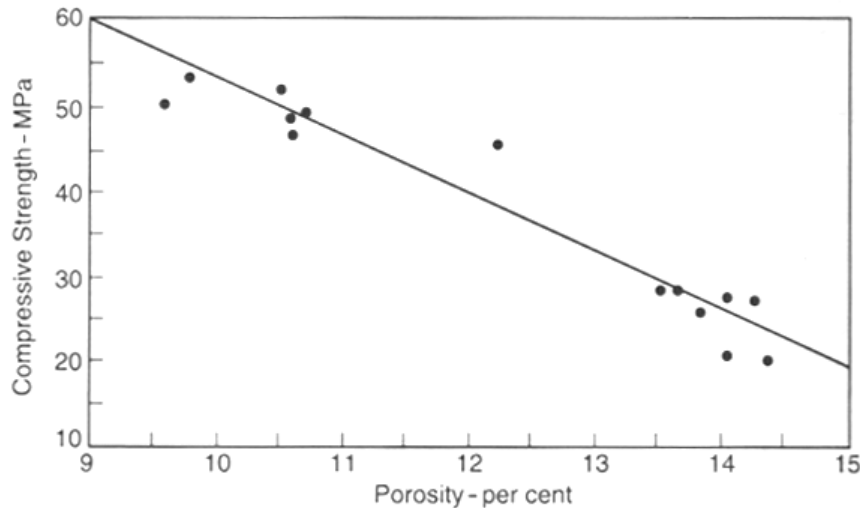


Figure 2.11 – Compressive Strength versus Porosity (Neville 1996)

Powers and Brownyard determined that the compressive strength is related to the gel-to-space ratio (Mindess et al. 2003). The gel-to-space ratio is defined as the ratio of the gel volume over the summation of the volume of the gel, capillary pores, and air voids. Powers and Brownyard concluded that the compressive strength of the hydrated cement is closely related to the following equation:

$$f_c = a * X^3 \quad \text{Eq. 2.6}$$

In equation 2.6, f_c is the strength of the material at a given porosity (p), a is the intrinsic strength of the material at zero porosity, and x is the gel-to-space ratio. Where this ratio is defined as the summation of the hydrated cement paste to the sum of the volume of the hydrated cement and capillary pores. The relationship between the gel-to-space ratio and the compressive strength can be seen in Figure 2.12. Bonen and Shah (2004) report that the compressive strength of SCC is also best approximated by the porosity content. They further suggest that similar to the Powers and Brownyard formulation, the compressive strength of SCC is defined in terms of the binder-to-space ratio, b rather than the gel-to-space ratio, x . The binder-to-space ratio is defined as the binder volume over the summation of the volume of the binder, capillary pores, and air voids. The binder volume is the sum of the gel volume, filler volume, and the solid volume of the superplasticizers and VMA.

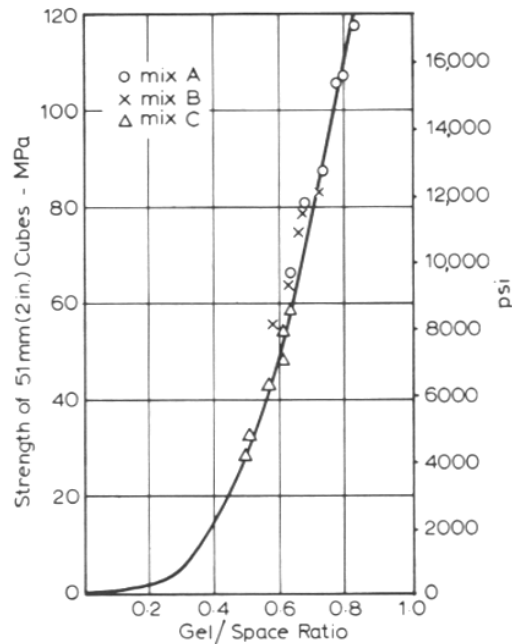


Figure 2.12 - Strength versus Gel-to-Space Ratio Based on Tested Mortar Cubes (Neville 1996)

In most cases, high contents of fine material are placed within SCC to increase segregation resistance. This addition of fine material can be capable of producing a denser microstructure that will decrease both the porosity of the cement paste matrix and interfacial transition zone of SCC. A study conducted at the Swedish Cement and Concrete Research Center investigated the microstructure in SCC and conventional bridge concretes using image analyzing and light microscopy techniques (Tragardh 1999). It was concluded that the porosity of the bulk paste and the ITZ was significantly higher in the conventional concrete compared to SCC with the same water-to-cementitious ratio (Tragardh 1999). It must be noted that although the SCC and conventional concrete had the same water-to-cementitious ratio, the SCC incorporated high amounts of fine inert limestone filler that produced a low water-to-binder ratio. The incorporation of fine material in the SCC allowed particles to pack more efficiently

around the aggregates; therefore, leading to a decrease in porosity around the ITZ. Tragardh (1999) further concluded that pores were more evenly distributed between the ITZ and bulk paste, and the effect of microbleeding, which leads to an increase of the local water-to-cementitious ratio at the interfacial zone, was found to be much less in SCC. It was further determined that the compressive strength for SCC was higher than the conventional concrete at the same water-to-cementitious ratio due to this improvement in the microstructure (Tragardh 1999). The results from the compressive strength test can be seen in Figure 2.13. This investigation determined that the microstructure properties not only improved in SCC, but shows a strong correlation between these microstructure properties and the measured properties (Tragardh 1999).

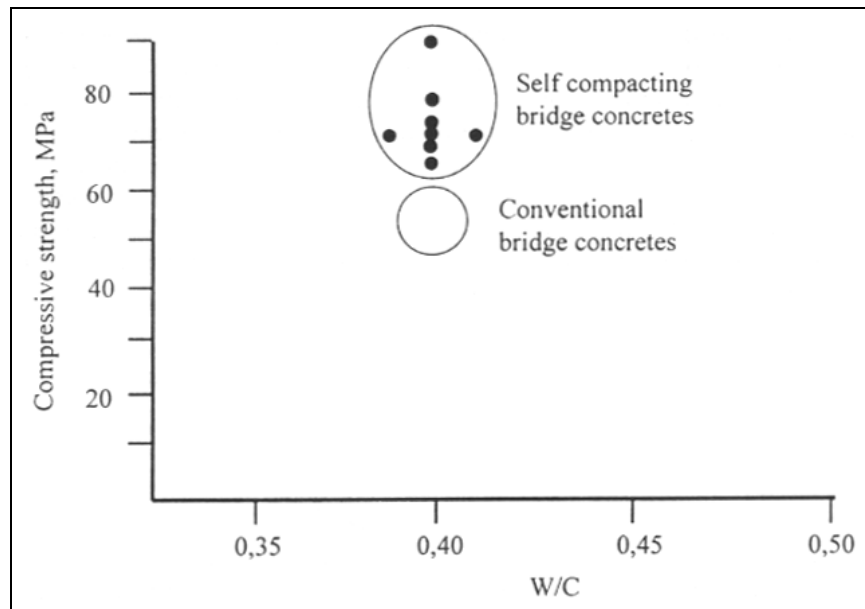


Figure 2.13 – Average Compressive Strengths of SCC and Conventional Bridge Concretes with w/c of 0.40 (Tragardh 1999)

A study conducted at the Master Builders Research and Development Center also compared the engineering properties of SCC and conventional concrete (Attiogbe et

al. 2003). The study used both conventional concrete and SCC with a cement content of 640 lb/yd³ and 160 lb/yd³ of fly ash with a water-to-cementitious ratio of 0.37. The specimens were either steamed or air cured in molds for 24 hours. Compressive tests were then conducted at the ages of 1 and 28 days. The research indicated that the early-age porosity was lower in the SCC than the conventional concrete (Attiogbe et al. 2003). Attiogbe et al. (2003) reported that the compressive strengths for 1 day and 28 day of the steamed-cured SCC were comparable to the steamed-cured conventional concrete. It was further reported that the compressive strength for the air-cured SCC exceeded the strengths of the air-cured conventional concrete. Furthermore, Turcry et al. (2003) reported on values that indicate that at similar water-to-cementitious ratios, the compressive strength of SCC is comparable or higher than conventional concrete. The results from this study can be seen by looking at Table 2.3.

Table 2.3 - Compressive Strength Results from Turcry et al. (2003)

	SCC 1	OC 1	SCC 2	OC 2
Gravel (lb/yd³)	1331	1803	1424	1912
Sand (lb/yd³)	1449	1314	1364	1348
Cement (lb/yd³)	590	607	590	665
Limestone Filler (lb/yd³)	253	0	421	0
Water (lb/yd³)	315	286	269	295
Water/Cement Ratio	0.53	0.47	0.46	0.44
Water/Powder Ratio	0.37	0.47	0.27	0.44
Sand/Aggregate Ratio (by mass)	0.52	0.41	0.48	0.41
Compressive Strength (psi)	6960	7400	8700	7251
Modulus of Elasticity (1 x 10⁶ psi)	4.35	5.50	5.20	5.20

OC = Ordinary Concrete

2.4.2 Modulus of Elasticity

For structural design, the modulus of elasticity of concrete increases approximately with the square root of its strength. According to the ACI 318 (2002), the modulus of elasticity of concrete can be best approximated by Equation 2.7.

$$E_c = 33 w_c^{1.5} \sqrt{f'_c} \quad \text{Eq 2.7}$$

In Equation 2.7, E_c is the modulus of elasticity in psi, w_c is the unit weight in lb/ft³, and f'_c is the compressive strength in psi. It is suggested that this formulation is valid for density ranging from 90 to 155 pcf and compressive strengths up to 6000 psi. The ACI Committee 363 (2002) “State-of-the-Art- Report on High Strength Concrete” also found that the equation used by ACI 318 (2002) was valid only up to compressive strengths up to 6000 psi. According to the ACI Committee 363 (2002) “State-of-the-Art- Report on High Strength Concrete”, high strength concrete has compressive strengths ranging from 6,000 to 12,000 psi. By comparing stress-strain curves for normal and high strength concrete, high strength concrete has a more linear and steeper slope in the ascending portion of the curve as well as a higher strain at the maximum stress (Jones 2004). Therefore, the ACI Committee 363 (2002) recommends the following equation for estimating the modulus of elasticity for high strength concrete, which is valid for compressive strengths ranging from 3,000 to 12,000 psi. In Equation 2.8, E_c is the modulus of elasticity in psi and f'_c is the compressive strength in psi.

$$E_c = 40,000\sqrt{f'_c} + 1,000,000 \quad \text{Eq. 2.8}$$

In contrast to the compressive strength, the modulus of elasticity of concrete is significantly affected by the modulus and volume fraction of the aggregate (Bonen and Shah 2004). Bonen and Shah (2004) report that as the volume fraction of aggregate is increased, the modulus of elasticity is increased. This is an important factor for SCC since the aggregate volume fraction is typically lower compared to conventional concrete. It is then expected that the elastic modulus of SCC would be lower than conventional concrete with the same strength (Bonen and Shah 2004). In addition to the limited aggregate volume fraction, SCC typically incorporates a higher sand-to-aggregate ratio to increase its segregation resistance and passing ability. Therefore, a closer examination must be presented to determine how the sand-to-aggregate ratio and aggregate volume fraction influence the modulus of elasticity.

Su et al. (2002) investigated the effect of the sand-to-aggregate ratio on the elastic modulus of SCC. Their study consisted of varying the sand-to-aggregate ratio of SCC from 0.30 to 0.55 while maintaining a constant aggregate volume fraction of 0.6 and a water-to-cementitious ratio of 0.39. By maintaining a constant water-to-cementitious ratio and aggregate volume fraction, only the varying sand-to-aggregate ratio should influence the elastic modulus. Su et al. (2002) also investigated how the elastic modulus of the fine and coarse aggregate influence the modulus of elasticity. The results from this study can be seen by looking at Figure 2.14. Su et al. (2002) reported that when the elastic modulus of the fine aggregate was 2 times that of the coarse aggregate, the elastic modulus of concrete increased from 4.05×10^6 psi to 4.3×10^6 psi when the sand-to-aggregate ratio increased from 30% to 47.5%. It is further reported that when the elastic modulus of the fine aggregate was half of the coarse aggregate, the elastic modulus

decreased from 3.26×10^6 psi to 3.05×10^6 psi when the sand-to-aggregate ratio increased from 30% to 47.5%. Su et al. (2002) concluded that when the elastic modulus of the fine and coarse aggregate are not much different and the total volume fraction of aggregate is constant, the elastic modulus of SCC is not significantly affected by the sand-to-aggregate ratio (Su et al. 2002).

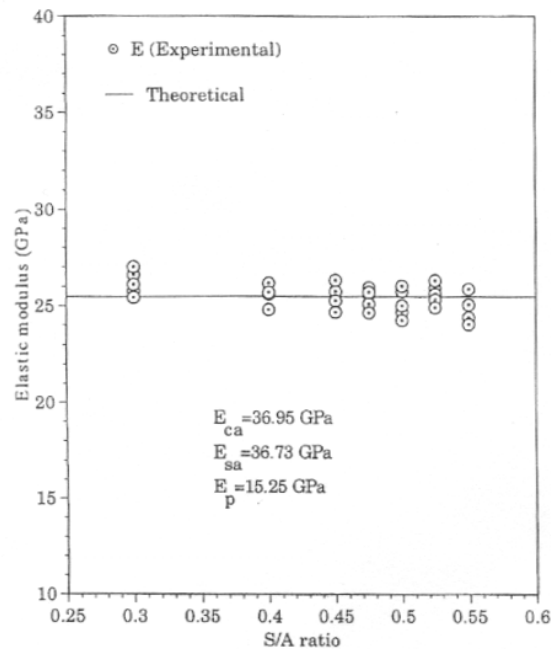


Figure 2.14 - Elastic Modulus versus Sand-to-Aggregate Ratio (Su et al. 2002)

Turcry et al. (2003) further compared the elastic modulus of SCC to conventional concrete using two SCC mixtures and two conventional concrete mixtures. Turcry et al. (2003) maintained a sand-to-aggregate ratio of 0.41 for the conventional concrete and sand-to-aggregate ratios of 0.52 and 0.48 for the SCC mixtures. Table 2.3 indicates that the conventional concrete had a higher aggregate fraction as well as a lower sand-to-aggregate ratio. Turcry et al. (2003) concluded that due to the higher paste volume for SCC, the elastic modulus for SCC was lower than conventional concrete at the same

compressive strengths. On the other hand, Attiogbe et al. (2003) reported that the modulus of elasticity for the SCC mixtures corresponded well with the conventional concrete when the strength was held constant. The study conducted by Attiogbe et al. (2003) used the same water-to-cementitious ratio of 0.37 with sand-to-aggregate ratios by mass of 0.44 for conventional concrete and 0.53 for the SCC mixtures. The concrete mixtures contained cement and fly ash of 650 lb/ft³ and 160 lb/yd³, respectively. Therefore, both the conventional concrete and SCC has comparable aggregate volume fractions with varying sand-to-aggregate ratios (Table 2.3).

2.4.3 Drying Shrinkage

Shrinkage is a term that represents the strain caused by the loss of water from hardened concrete (Mindess et al. 2003). Shrinkage of concrete is a function of the paste properties, and the response of the paste to moisture loss is modified by several parameters. However, the most important parameter is exerted by the aggregate, which will restrain the shrinkage (Neville 1996). Equation 2.9 states that the ratio of shrinkage of concrete, S_c , to the shrinkage of neat cement, S_p , depends on the aggregate content, a , and the experimental values of n range from 1.2 to 1.7 (Neville 1996).

$$S_c = S_p (1 - a)^n \quad \text{Eq. 2.9}$$

Since SCC incorporates high paste volumes and reduced aggregate content, Equation 2.9 reveals that SCC is prone to an increase in drying shrinkage compared to conventional concrete. Neville (1996) suggest that for a constant water-to-cementitious ratio, the reduction in aggregate content will cause an increase in drying shrinkage. This relationship between water-to-cementitious ratio and aggregate content can be seen in Figure 2.15.

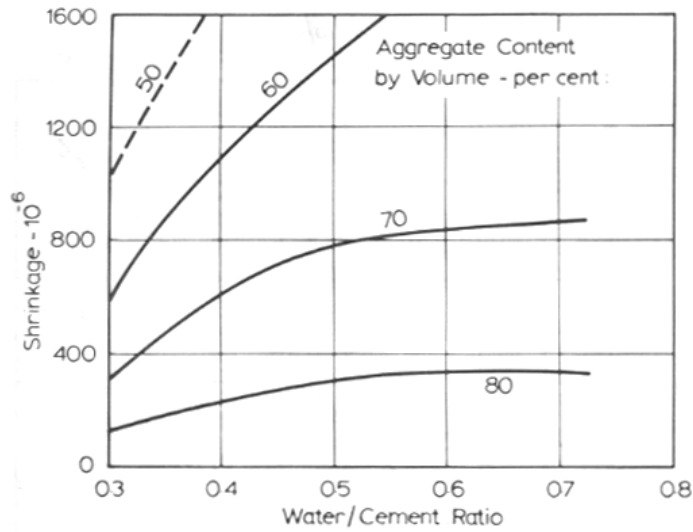


Figure 2.15 - Aggregate Content versus Water-to-Cement Ratio (Neville 1996)

Neville (1996) reports that the size and gradation of aggregate *per se* does not influence the magnitude of shrinkage, but the use of larger aggregate permits a leaner mix that results in lower shrinkage. On the other hand, the ACI Committee 209 (2002) suggests that the gradation of the aggregate may have an effect on the drying shrinkage. According to ACI Committee 209 (2002), for different sand-to-aggregate ratios the shrinkage should be modified according to Equation 2.10 and 2.11. It can be seen from Equation 2.10 and 2.11 and Figure 2.16 that as the sand-to-aggregate ratio is increased, which indicates more fine aggregate, the shrinkage will also increase. In Equation 2.10 and 2.11, ψ is the sand-to-aggregate ratio.

$$\text{Shrinkage} = 0.30 + 0.014\psi \quad \psi < 50\% \quad \text{Eq. 2.10}$$

$$\text{Shrinkage} = 0.9 + 0.002\psi \quad \psi \geq 50\% \quad \text{Eq. 2.11}$$

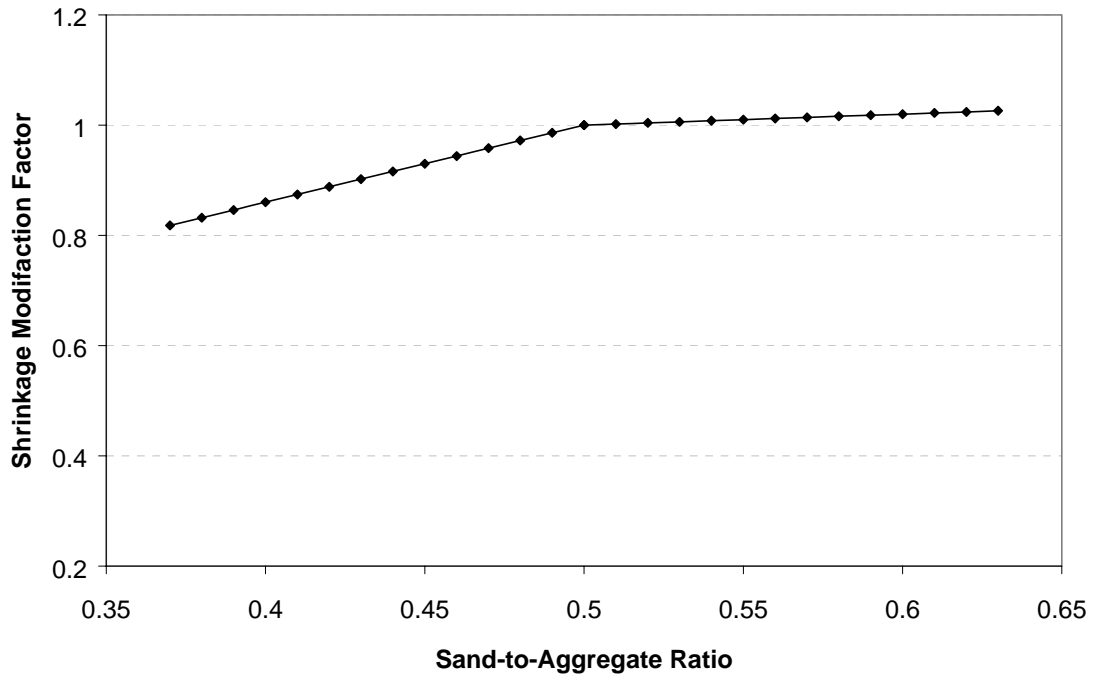


Figure 2.16 – Shrinkage Modification Factor for Different Sand-to-Aggregate Ratios (ACI Committee 209 2002)

Neville (1996) goes on to report that at constant water contents, the shrinkage is decreased with increasing cement content. In the same manner, at constant cement contents, the shrinkage is decreased with decreasing water content. This is due to the fact that as the water-to-cementitious ratio is decreased it is able to better resist shrinkage; therefore, the drying shrinkage is decreased as shown in Figure 2.17. Since SCC typically has a lower water-to-cementitious ratio compared to conventional concrete, it may be possible that the increase in shrinkage caused by the reduction in aggregate content or increase in sand-to-aggregate ratio can, to a certain degree, be compensated by the reduction of the water-to-cementitious ratio.

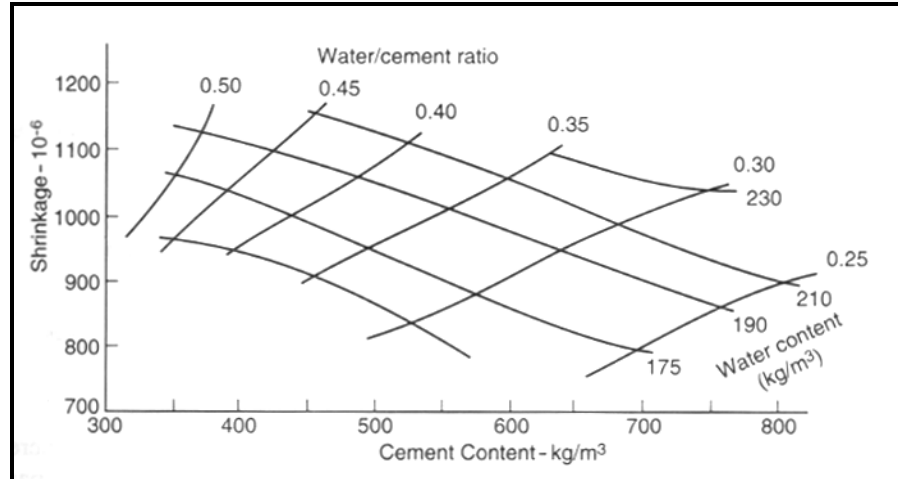


Figure 2.17 – Shrinkage versus Cement Content (Neville 1996)

Kim et al. (1998) studied the drying shrinkage of SCC and conventional concrete made with fly ash in which the paste fraction and volume ratio of coarse aggregate-to-concrete varied. The basic mixture proportions and experimental results are shown in Table 2.4 and Figure 2.18. Kim et al. (1998) concludes that the experimental results show the effects of the water weight and volume ratio of coarse aggregate-to-concrete on drying shrinkage. It was determined that with increasing unit water weight and decreasing volume ratio of coarse aggregate-to-concrete, the drying shrinkage was increased (Kim et al. 1998). The reported results from this experiment indicate that the drying shrinkage for SCC was 30% to 50% greater than conventional concrete. Kim et al. (1998) concludes that the higher drying shrinkage for the SCC mixtures is due to the higher paste volumes, higher water contents, and less coarse aggregate. Additionally, Rols et al. (1999) reported that for their research the drying shrinkage values for SCC were 50% higher than conventional concrete containing the same amount of cement. It was determined that the increase in drying shrinkage was due to the increase in the paste fraction and decrease in coarse aggregate.

Table 2.4 - Mixture Proportions (Kim et al. 1998)

Mix ID	Water lb/yd ³	Binder		Aggregate		Total Aggregate ft ³	W/C Ratio	Sand/Aggregate Ratio (By Volume)
		Cement lb/yd ³	Fly Ash lb/yd ³	Fine lb/yd ³	Coarse lb/yd ³			
Self-Consolidating Concrete								
SF 1-1	328	657	281	1371	1235	16.1	0.35	0.53
SF 1-2	311	623	267	1317	1381	16.7	0.35	0.49
SF 1-3	295	590	253	1245	1545	17.2	0.35	0.45
SF 1-4	278	556	238	1142	1739	17.8	0.35	0.40
SF 2	320	505	337	1311	1380	16.6	0.38	0.49
Ordinary Concrete								
NC 2	295	674	0	1305	1744	18.8	0.44	0.43
NC 3	295	843	0	1141	1739	17.8	0.35	0.40

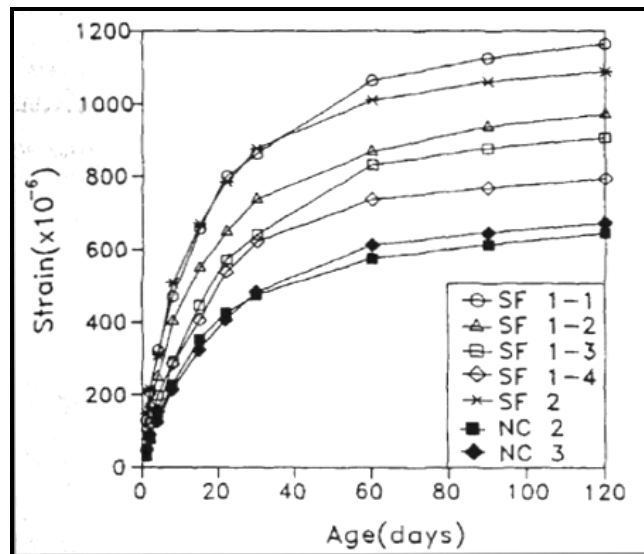


Figure 2.18 - Drying Shrinkage versus Age (Kim et al. 1998)

In contrast, experiments performed by Raghavan et al. (2003) indicate that for their research the conventional concrete specimens exhibited more drying shrinkage than the SCC specimens. The materials used for SCC were the same as conventional concrete with material proportions for SCC consisting of a lower water-to-binder ratio and a

higher sand-to-aggregate ratio. In addition, the water weight for the conventional concrete and the SCC was the same in all cases. A summary of the results from this study can be seen in Figure 2.19. The results indicate that the drying shrinkage of SCC was 25% less than conventional concrete. It is suggested that this reduction in shrinkage can be attributed to the effect of paste volume and decreased water-to-binder ratio. Raghavan et al. (2003) reports that for the same water content and decreased water-to-binder ratio, the drying shrinkage is reduced in SCC.

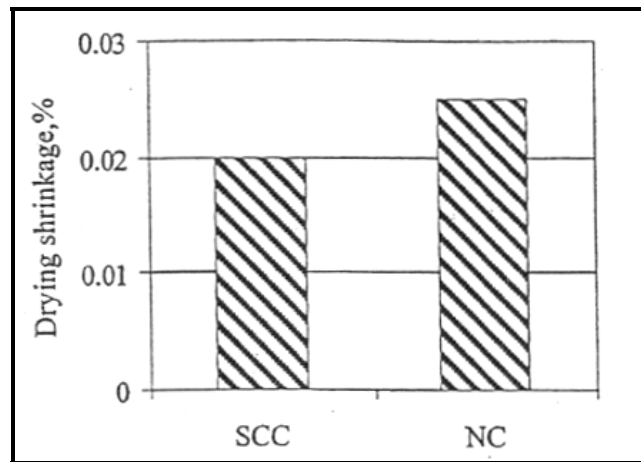


Figure 2.19 - SCC versus Normal Concrete (Raghavan et al. 2003)

Further studies conducted by Attiogbe et al. (2003) evaluated the effect of the sand-to-aggregate ratio on drying shrinkage of SCC. SCC mixtures were prepared at a cement content of 850 lb/yd³, water-to-cementitious ratio of 0.34, and sand-to-aggregate ratios of 0.58, 0.48, and 0.39, respectively. It can be seen from Figure 2.20 that as the sand-to-aggregate ratio increased the drying shrinkage also increased. This report indicates that increasing the sand-to-aggregate ratio can have an effect on the drying shrinkage.

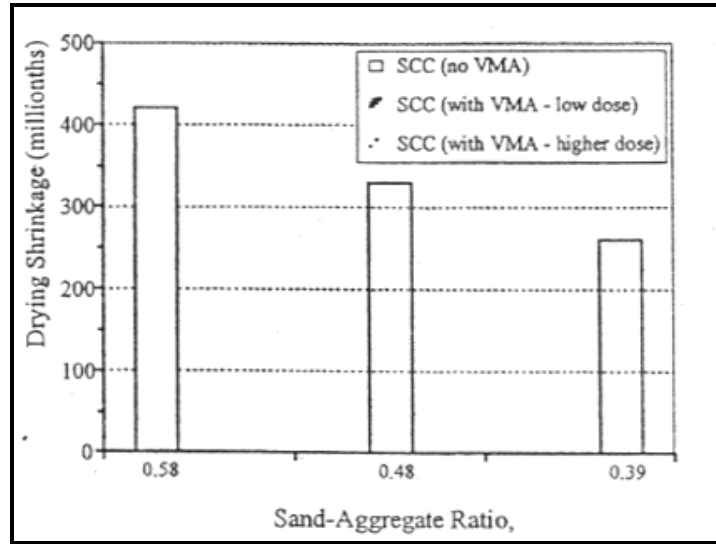


Figure 2.20 - Drying Shrinkage versus Sand-to-Aggregate Ratio (Attiogbe et al. 2003)

2.4.4 Permeability

Permeability is an important factor in the durability of concrete structures because it controls the entry rate and the movement of moisture that may contain aggressive chemicals (Mindess et al. 2003). The permeability of concrete is related to the pore system within the bulk of the hardened cement paste and the zone near the interface between the cement paste and the aggregate (Neville 1996). Thus, the permeability of concrete is not just a simple function of the porosity, but depends on the size, shape, distribution, and continuity of the pores within the paste (Neville 1996). Neville (1996) suggests that the permeability of hardened cement paste is controlled by its capillary porosity as shown in Figure 2.21. Furthermore, Figure 2.22 shows that the capillary volume increases rapidly for water-to-cementitious ratios greater than 0.42.

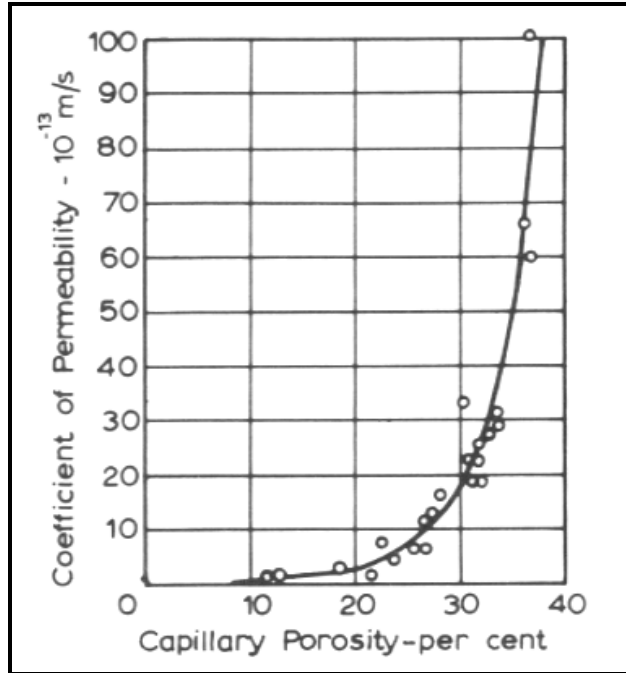


Figure 2.21 – Coefficient of Permeability versus Capillary Porosity (Neville 1996)

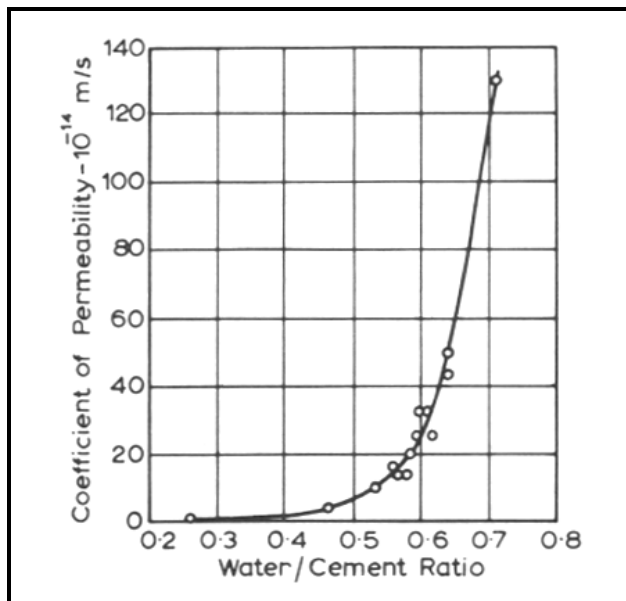


Figure 2.22 – Coefficient of Permeability versus Water-to-Cement Ratio (Neville 1996)

The permeability of concrete is also influenced by the properties of the cementitious materials and presence of aggregate. The interfacial transition zone, which has a different microstructure than the bulk paste as well as a locus of microcracking, can make up one-third to one-half of the total volume of the hardened cement paste (Neville 1996). As a result, the interfacial transition zone can be expected to contribute to the permeability of concrete. However, it is argued that if the aggregate has low permeability, its presence reduces the effective area that flow may take place and the effective flow path becomes longer so that the permeability of concrete may be reduced (Neville 1996). Thus, the presence of the interfacial transition zone on the permeability still remains uncertain. Nevertheless, SCC typically incorporates high amounts of fine material and low water-to-binder ratios, which may lead to a denser microstructure within the bulk paste as well as the interfacial transition zone. Thus, it would be expected that SCC has a lower permeability compared to conventional concrete.

Research conducted by Raghavan et al. (2003) reported on rapid chloride penetration tests (RCPT) values of SCC ranging from 1100-1500 coulombs and an average of 4000 coulombs for conventional concrete. Figure 2.23 shows the results from this study. Raghavan et al. (2003) concludes that the reduction in permeability is due to the high filler material and lower water-to-binder ratio for the SCC mixtures. This allowed the SCC to develop a denser microstructure than the conventional concrete with higher water-to-cementitious ratios. Studies conducted by Attiogbe et al. (2003) also indicate that the porosity of SCC was found to be lower than conventional concrete, indicating the potential for better long-term durability for SCC compared to conventional concrete. Thus, it can be determined that even at the same water-to-cementitious ratios,

SCC mixtures can produce a denser microstructure than conventional concrete due to better particle packing.

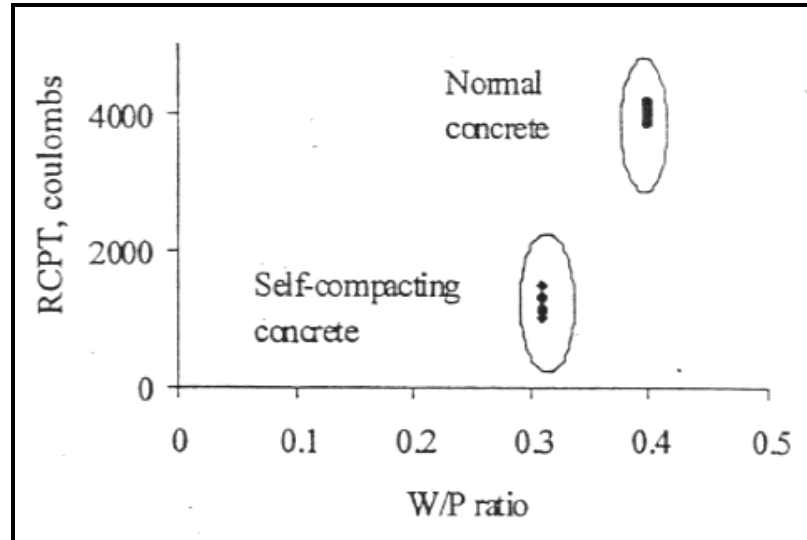


Figure 2.23 - RCPT Values of SCC and Normal Concrete (Raghavan et al. 2003)

2.5 SUMMARY AND CONCLUSIONS

- Self-consolidating concrete is able to fill formwork, encapsulate reinforcement bars, and consolidate under its own weight. At the same time it is cohesive enough to maintain its homogeneity without segregation or bleeding.
- Rilem Report 23 from Technical Committee 174-SCC (Skarendahl 2000) suggests that three main functional requirements of SCC are as follows:
 - a. **Filling Ability:** The ability of the concrete to completely fill formwork and encapsulate reinforcement without the use of external vibration.
 - b. **Passing Ability:** The ability of the concrete to pass through restrictive sections of formwork and tightly spaced reinforcement bars without blockage due to interlocking of aggregate.

- c. **Segregation Resistance:** The ability of the concrete to keep particles in a homogenous suspension throughout mixing, transportation, and placement.
- The slump flow test is one of the most common and popular test to evaluate the deformation capacity of SCC because the procedure and apparatus is relatively simple.
 - One of the most critical requirements for SCC is that it must not segregate during or after placement.
 - The VSI rating of the slump flow patty is considered part of the **dynamic** stability given the fact the concrete can exhibit some non-uniform texture following some mixing and transport; whereas, the VSI can be considered as a **static** stability index when it is observed in the wheelbarrow or mixer following some period of rest time.
 - The L-Box and J-Ring is used to assess the passing ability of a SCC mixture.
 - The segregation column test is used to determine the stability and segregation resistance of a SCC mixture.
 - The following actions should be taken to achieve adequate filling ability (Khayat and Tangtermsirikul 2000):
 - **Increase the deformability of the paste.**
 1. Balanced water/powder ratio (Balanced so that adequate deformability and deformation velocity can be achieved)
 2. Superplasticizers

- **Reduced interparticle friction.**
 1. Low coarse aggregate volume
 2. Higher paste content

- To achieve suitable passing ability the following steps should be considered (Khayat and Tangtermsirikul 2000):
 - **Enhance the cohesiveness to reduce segregation of aggregate.**
 1. Low water/binder ratio
 2. Viscosity modifying admixture

 - **Compatible clear spacing and aggregate characteristics.**
 1. Low coarse aggregate content
 2. Small maximum aggregate size

- The following steps should be considered to produce sufficient segregation resistance (Khayat and Tangtermsirikul 2000):
 - **Reduce the segregation of solid particles.**
 1. Reduced maximum size aggregate
 2. Low water/powder ratio
 3. Viscosity modifying admixture

 - **Minimize bleeding due to free water**
 1. Low water content
 2. Low water/powder ratio
 3. Powders with high surface area
 4. Viscosity modifying admixture

- The porosity relationship can be considered one of the most important factors in cement based materials because it affects both the cement paste matrix and the interfacial transition zone (ITZ).

- The modulus of elasticity of concrete is affected by the modulus and volume fraction of the aggregate.
- When the elastic modulus of the fine and coarse aggregate are not much different and the total volume fraction of aggregate is constant, the elastic modulus of SCC is not significantly affected by the sand-to-aggregate ratio.
- Shrinkage of concrete is a function of the paste properties, and the most important parameter is exerted by the aggregate, which will restrain the shrinkage.
- Even at the same water-to-cementitious ratios, SCC mixtures can produce a denser microstructure than conventional concrete due to better particle packing resulting in lower permeability values.

CHAPTER 3

EXPERIENCES WITH DRILLED SHAFT CONCRETE

A review of literature relevant to experiences with drilled shaft concrete is presented in this chapter. This chapter will address several aspects of design and construction that are essential for high-quality drilled shaft concrete and problems that are encountered in drilled shaft construction that may lead to poor quality drilled shaft foundations. Selected examples of more common problems associated with drilled shaft concrete are cited in this chapter so that the mechanisms that cause these problems can be understood. The literature presented in the FHWA Drilled Shaft Manual, “Construction Procedures and Design Methods” (O’Neill and Reese 1999) is considered to be the current state of practice for drilled shaft design and construction. Therefore, it is recommended that the FHWA Drilled Shaft Manual, “Construction Procedures and Design Methods” (O’Neill and Reese 1999) be reference material for the reader not familiar with drilled shaft concrete, construction procedures, and design. It must be noted that the problems associated with drilled shaft concrete and cited examples in this chapter are not based on the author’s experience. Rather they are based on observations and experience of other experienced engineers.

3.1 INTRODUCTION

Recently developed techniques in integrity and load testing have given engineers and contractors the ability to assess the quality of drilled shaft foundations after they have

been cast. These techniques have also provided insight to problems that are associated with materials and construction practices that have lead to defects or less than optimal performance in drilled shaft foundations. Some of the most common issues that comprise the quality of drilled shaft foundations due to drilled shaft concrete come from the failure to consider one or more of the following:

1. Retained workability of the concrete mixture for the duration of the pour
2. Blockage of the coarse aggregate due to congested rebar cages
3. Segregation and bleeding of the drilled shaft concrete

3.2 WORKABILITY OF DRILLED SHAFT CONCRETE

A number of terms are commonly used to describe a different aspect of concrete behavior: consistency, flowability, pumpability, and compactability (Mindess et al. 2003). Workability is often used to represent all the terms mentioned above; however, these terms are often subjective and mean different things to different people. Therefore, a more precise definition should be given to describe this property of a concrete mixture. Mindess et al. (2003) states that workability is described in terms of the amount of mechanical work or energy required to achieve full compaction of a concrete mixture without segregation. Other definitions provided by ASTM and ACI suggest that workability can be defined as the effort required to manipulate the fresh concrete without the loss of homogeneity (ASTM) or the ease in which concrete can be mixed, placed, consolidated, and finished (ACI) (Neville 1996). In drilled shaft construction, full compaction or consolidation of a concrete mixture must be achieved without the use of external energy. For drilled shaft concrete, O'Neill and Reese (1999) describe the

workability in terms of the ability of a concrete mixture to readily flow through the tremie, flow laterally through rebar cage, and impose a high lateral stress against the sides of the borehole wall without the use of external vibration. As a result, high workability is one of the most important characteristics for drilled shaft concrete.

There have been many methods developed over the years to determine the workability of concrete mixture: slump test, compaction test, flow test, and Vebe test. However, the slump test, ASTM C 143 (1998), is the oldest and most widely used test for determining the workability of a concrete mixture for drilled shaft construction (O'Neill and Reese 1999). Although some organizations such as the California Department of Transportation (Caltrans) use ASTM C 360 (1998) "*Standard Test Method for Ball Penetration in Freshly Mixed Hydraulic Cement Concrete*" in lieu of the slump test. ASTM C 360 (1998) correlates the depth of penetration of 30 ± 0.1 lb cylinder with a hemispherical shaped bottom with results of ASTM C 143 (1998). It should be noted that these tests do not measure the true workability of concrete mixture, but rather is a measure of consistency. However, a concrete mixture with the same consistency may vary in workability. Nevertheless, these tests are very useful in detecting variations in a concrete mixture, and it gives an indication of how a drilled shaft concrete mixture will perform.

FHWA recommendations for drilled shaft concrete state that a slump of 6 inches or higher should be used for the dry method, and 8 inches when the wet or casing method is used (O'Neill and Reese 1999). The FHWA guidelines go on to advise that good drilled shaft concrete should have an appearance of collapsible concrete that will fall freely when the slump cone is removed (O'Neill and Reese 1999). Brown (2004)

suggests that experienced workers often describe quality drilled shaft concrete as having a creamy paste rather than a boney texture. Figure 3.1 shows a drilled shaft concrete mixture that is on the lower end of allowable slump values that may be suitable for dry-hole construction. Figure 3.2 shows a drill shaft concrete mixture that may be suitable for both dry and wet-hole construction.



Figure 3.1 – Drilled Shaft Mixture with a Slump of Approximately 6.5 Inches (Annual ADSC Short Course)



Figure 3.2 – Drilled Shaft Mixture with a Slump of 8-9 Inches (O’Neill and Reese 1999)

O’Neill and Reese (1999) state that to achieve the high workability that is needed for drilled shaft concrete, a high water-to-cementitious ratio ranging from 0.5 to 0.6 can be used without the use of water reducers or incorporation of water reducers with a water-to-cementitious ratio of 0.45 or less. The former relies on more than half the water provided to lubricate the mix during concrete placement that is not necessarily needed for hydration. The latter relies on water reducers to reduce the amount of mixing water required to produce concrete of a certain slump by reducing the interparticle friction between the cement particles and water. Low-, mid-, and high-range water reducers (superplasticizers) have been used in drilled shaft construction. O’Neill and Reese (1999) suggest that with high-range water reducers, water-to-cementitious ratio as low as 0.3 can be used while maintaining a high slump.

Another important aspect of drilled shaft concrete in terms of workability is the consideration of the aggregate type and gradation. In general, rounded aggregate is typically preferred over crushed aggregate due to the increased workability for a given water content. Rounded aggregates will act like “ball bearings” while crushed aggregates will have more mechanical interlock and require more work to overcome internal friction (Mindess et al. 2003). The FHWA guidelines recommend that a well-graded coarse aggregate with a maximum size aggregate of $\frac{3}{4}$ in. be used (O’Neill and Reese 1999). The main reasons for these recommendations are to minimize the amount of paste in the mix, provide a concrete mixture that can readily flow through the rebar cage without any bridging of the aggregate at the vicinity of the reinforcement, and to prevent segregation of the concrete mixture (O’Neill and Reese 1999, and Brown 2004).

When tremie placement or temporary casing is utilized it is not only important to have sufficient workability initially, but it is also critical to maintain the workability for the duration of the pour. Controlled setting of the concrete mixture is necessary to allow for any construction delays in concreting, and to allow the temporary casing to be removed after concreting is completed. In general, set-retarding admixtures are used to control the setting that is necessary to complete the construction sequence. Set-retarding admixtures can be classified into 5 major categories (Mindess et al. 2003):

- Lignosulfonic acids and their salts
- Hydroxycarboxylic acids and their salts
- Sugars and their derivatives
- Phosphates and organic phosphate salts
- Salts and amphoteric metals such as lead, zinc, and tin

Set-retarding admixtures slow down the rate of early hydration of C_3S by extending the length of the induction stage which extends the setting times as determined by ASTM C 403 (1998) (Mindess et al. 2003). Mindess et al. (2003) states that organic retarders are able to absorb into the nuclei of the calcium hydroxide and inhibit their growth; however, once the acceleration stage of the hydration process begins the hydration proceeds as normal. Mindess et al. (2003) goes on to report that when inorganic retarding admixtures are utilized, they can form a coating around the C_3S particles that can severely reduce the rate of reaction. The extended length of the induction stage will depend on the effectiveness of the retarder and the amount added. Furthermore, replacement of cement by less reactive supplementary cementitious materials, such as fly ash, can also increase the time in which the concrete will remain workable.

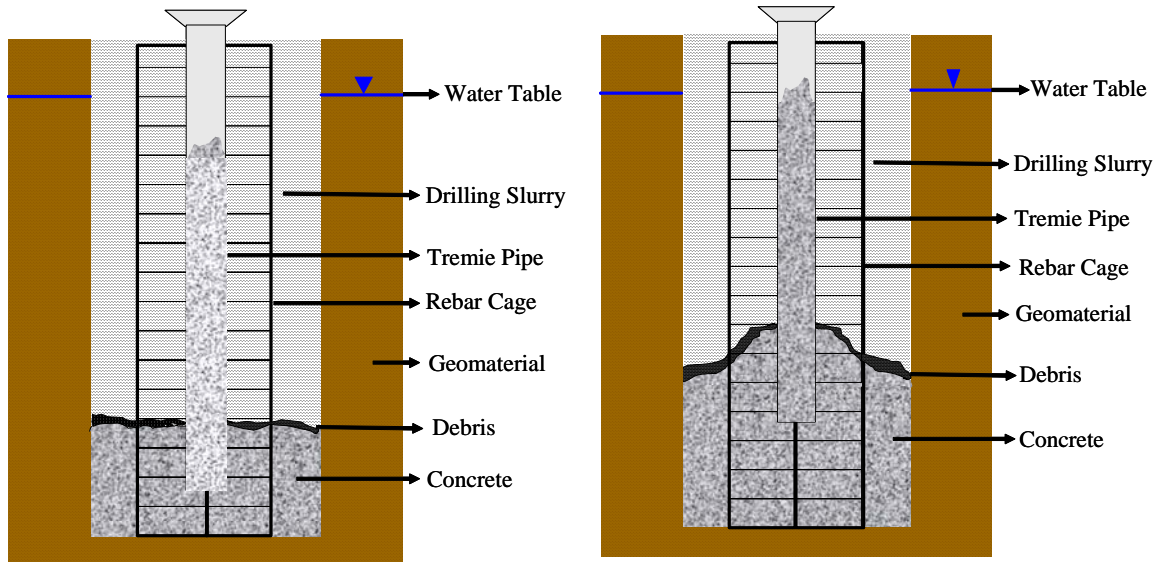
Recent results from integrity and load testing have shown that inadequate workability or loss of workability during the duration of concrete placement can lead to defects that are unfavorable for drilled shaft foundations. When drilled shaft concrete has insufficient workability the following problems can arise:

PROBLEM NO. 1- When tremie placing concrete as shown in Figures 3.3, the concrete should readily flow through the tremie, rebar cage, and displace the drilling slurry upward in one uniform horizontal layer. However, if workability is not maintained for the duration of the pour there is a probability that debris can become entrapped causing structural defects within the shaft as shown in Figure 3.4. The debris can come from suspended particles in drilling slurry, sloughed soil, and laitance settling onto the top of

the rising column of concrete. This debris can become entrapped when the concrete has sufficient workability when delivered to the job site, but over time loses its workability within the shaft. In this case, while the oldest concrete is riding on top of the rising column of concrete its beginning to have insufficient workability that may potentially lead to a difference in head between the outside of the rebar cage and the inside of the rebar cage. The fresh concrete being placed in the shaft will tend to erupt through this stiff concrete and trap debris that is on the outside of the rebar cage leading to structural defects. Furthermore, the loss of workability may also result in plugging of the tremie pipe because the oldest concrete has become too stiff to allow the fresh concrete to readily flow out of the tremie pipe. The contractor may make aggressive attempts to clear the tremie pipe and unintentionally or purposely extract the tremie resulting in debris seams to become entrapped or cause contamination of the concrete as shown in Figure 3.5. These construction issues are illustrated in Figures 3.4-3.10.

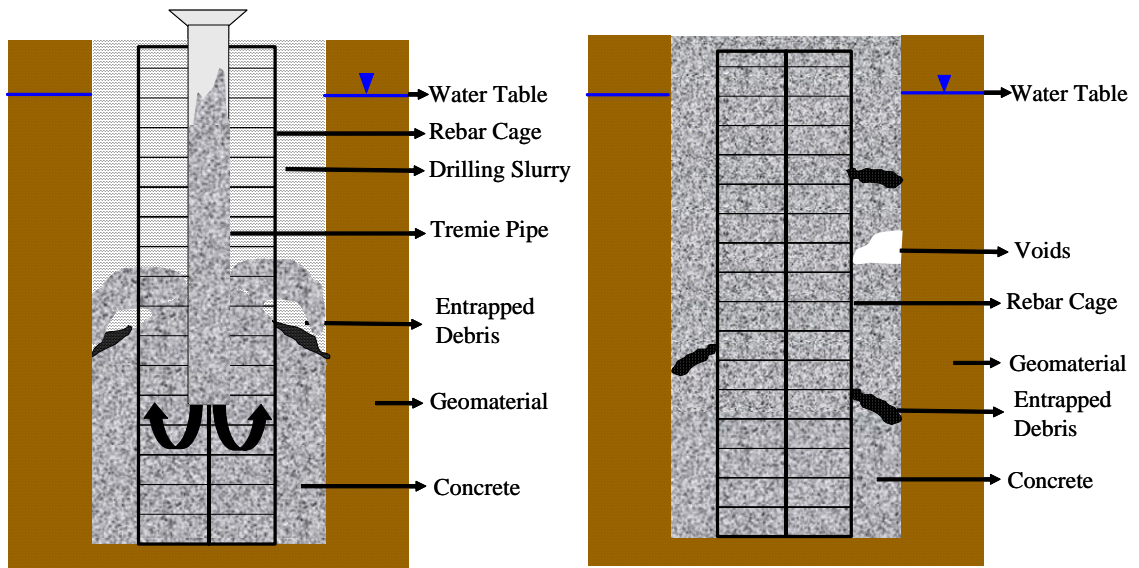


Figure 3.3 - Illustration of Tremie Placement (O'Neill and Reese 1999)



(A) Fresh concrete with sufficient workability being placed within the shaft.

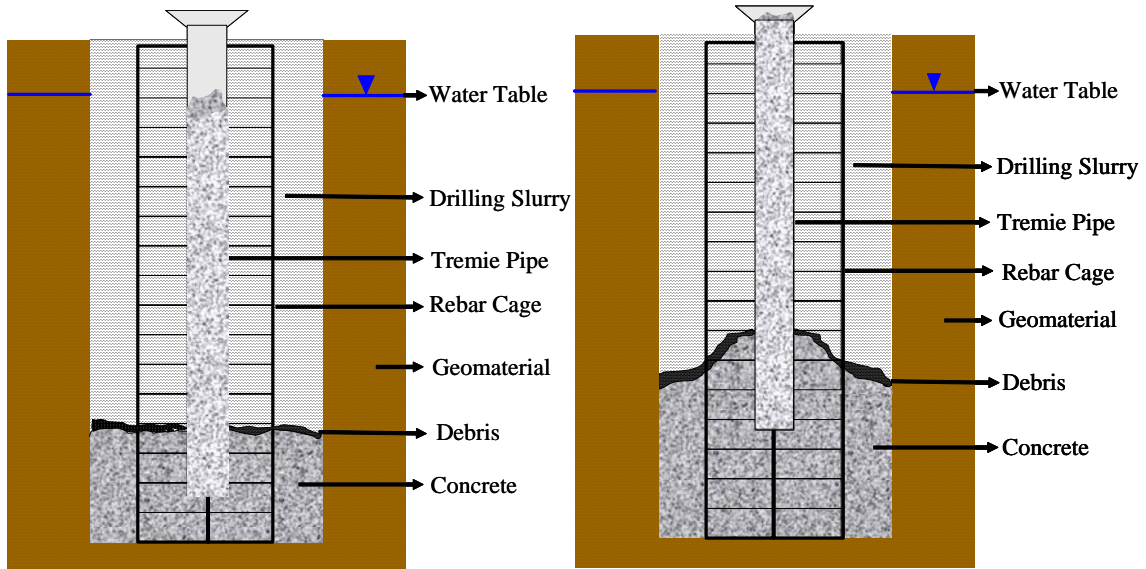
(B) Interruption in concrete supply allows concrete to lose its workability within the shaft.



(C) After concrete placement resumes, the fresh concrete that is introduced erupts through the stiff concrete and entraps debris on the outside of the rebar cage.

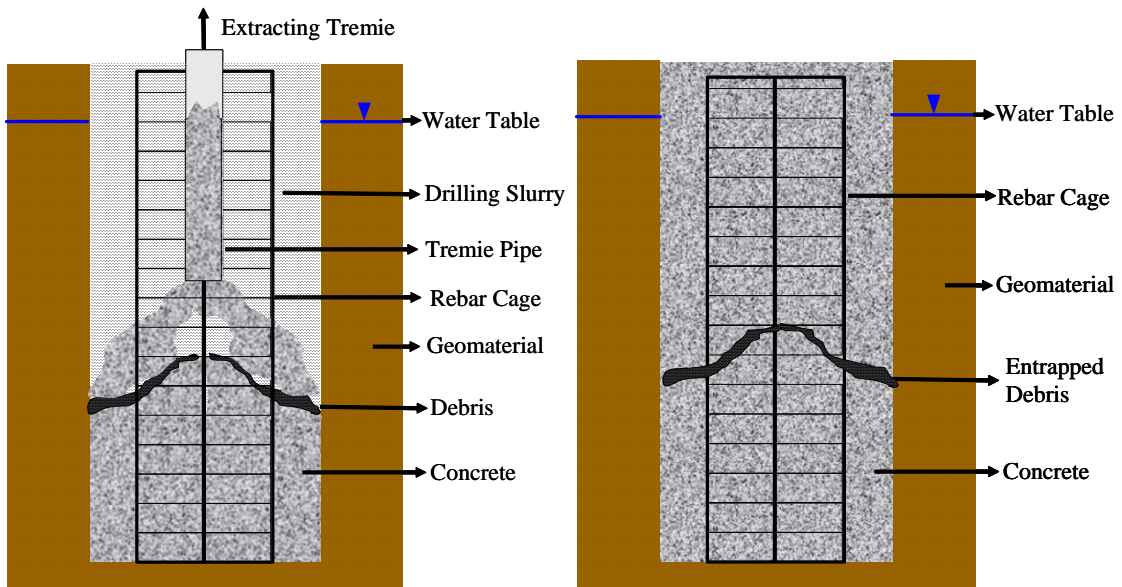
(D) Completed shaft with large pockets of entrapped debris and voids.

Figure 3.4 - Illustration of Entrapped Debris due to the Eruption of Fresh Concrete through Stiff Concrete



(A) Fresh concrete with sufficient workability being placed within the shaft.

(B) Interruption in concrete supply allows concrete to lose its workability within the shaft. As concrete placement resumes, the tremie becomes plugged.



(C) The contractor accidentally or purposely extracts the tremie to restart the flow again.

(D) Completed shaft with debris seams due to the extraction of the tremie.

Figure 3.5 – Illustration of Entrapped Debris Seams due to Extraction of the Tremie



Figure 3.6 - Example 1 of Shaft Defects due to the Loss of Workability (photograph courtesy of Dr. Dan Brown)



Figure 3.7 - Example 2 of Shaft Defects due to the Loss of Workability (TxDOT)



Figure 3.8 - Example 3 of Shaft Defects due to the Loss of Workability (TxDOT)



Figure 3.9 - Example 4 of Shaft Defects due to the Loss of Workability (Caltrans)



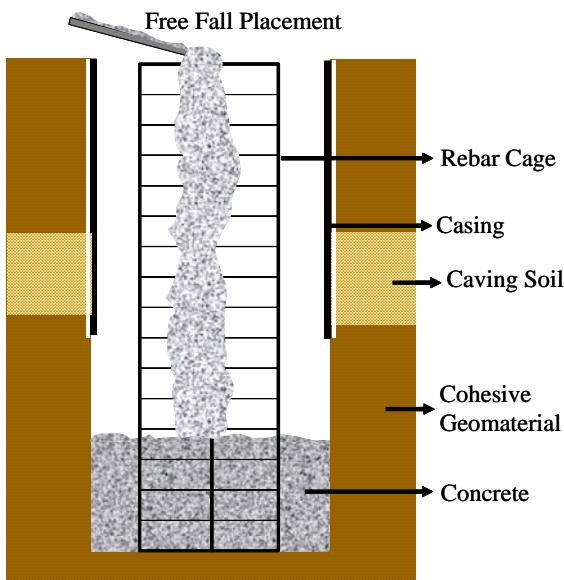
Figure 3.10 - Example 5 of Shaft Defects due to the Loss of Workability (TxDOT)

PROBLEM NO. 2- When concrete is placed into a cased hole as shown in Figure 3.11, there is a need for the concrete to maintain its workability throughout the duration of the pour. This maintained workability is essential because when the casing is removed the concrete must be able to flow laterally to displace any water that is present outside the casing, and produce a high lateral stress on the soil or rock so that there is adequate bond between the concrete and surrounding bearing stratum. Furthermore, if the concrete workability is lost before the casing is pulled, the casing may be very difficult to remove or in some cases not be able to be removed at all. If the casing is able to be removed, the concrete can tend to arch and be lifted with the casing causing a neck to be formed. Figure 3.13 shows an example when the concrete workability was lost before the casing was extracted. As a result, the concrete on the outside of the rebar cage was lifted along with casing leaving the rebar cage exposed. Even if no necking occurs, a stiff column of concrete has essentially been “slipped formed” into an oversized hole. As a result, the

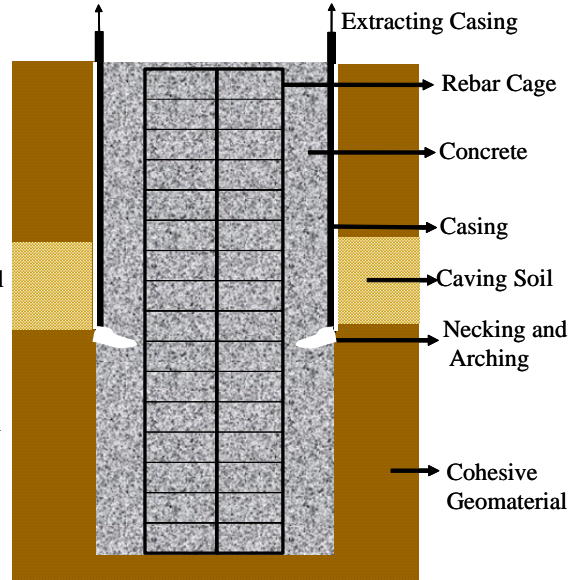
concrete can impose little or no lateral stress on surrounding soil or rock, and it can be expected that adequate bond between the concrete and bearing stratum will not be present. In addition, the presence of heavily congested rebar cages may also make matters worse because the concrete can be restricted by the cage after the casing is removed. The mechanism that may lead to poor defects when the casing is pulled is schematically shown in Figure 3.12.



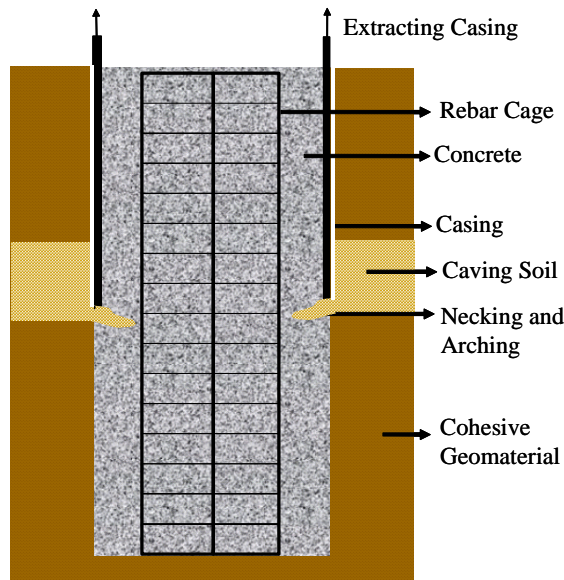
Figure 3.11 – Illustration of a Cased Hole (FDOT)



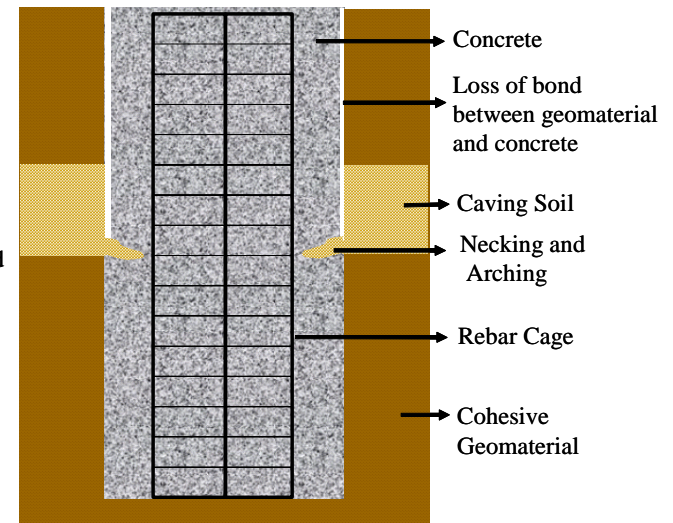
(A) Concrete being placed using casing method.



(B) Concrete placement is complete, but due to long periods of placement or construction delays the concrete workability has been lost. The casing is extremely difficult to remove and causes arching and necking to occur



(C) As casing is being extracted, loose material may slough into the neck and entrap debris.



(D) After the casing is pulled, the shaft has pockets of entrapped debris and loss of bond between the bearing stratum and concrete.

Figure 3.12 – Necking and Arching due to the Extraction of the Casing when Workability is Lost



Figure 3.13 - Shaft Defects due to the Extraction of the Casing (Annual ADSC Short Course)

One can infer from the discussion and illustrations above that the loss of concrete workability can have detrimental effects on drilled shaft foundations. Therefore, careful attention must be exercised by contractors and engineers to ensure that concrete workability be maintained. To ensure that proper workability and slump retention is achieved, O'Neill and Reese (1999) recommend that trial mixes should be conducted with the cementitious materials, aggregates, and additives that will be used for a particular application. They further state that a trial mix study for drilled shaft concrete should consist of constructing a graph of slump loss versus time after batching as shown in Figure 3.14. Figure 3.14 illustrates a slump loss relationship in which the slump loss diminishes slowly and exceeds 4 inches after 4 hours. Figure 3.14 also demonstrates an

undesirable slump loss wherein the initial workability is sufficient, but slump loss occurs rapidly after batching.

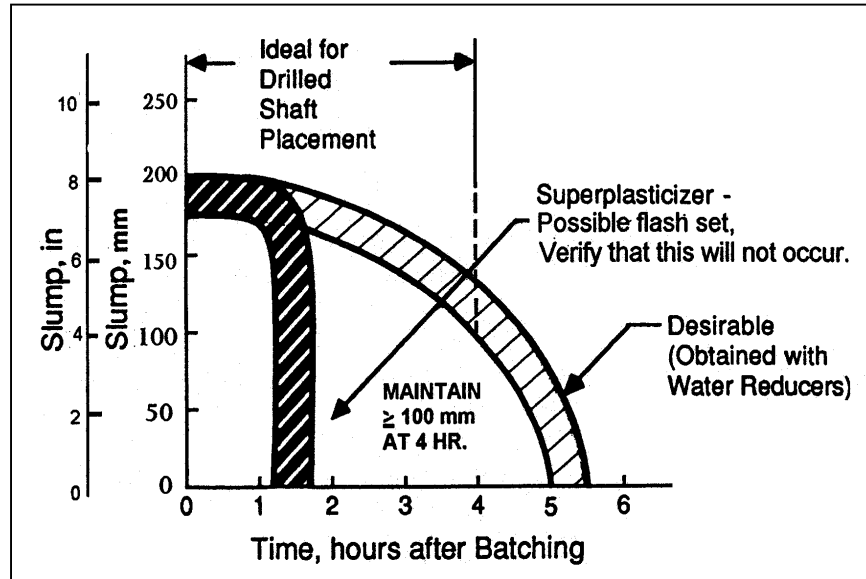


Figure 3.14 – Slump Loss versus Time Relationship (O’Neill and Reese 1999)

When constructing the slump loss graph, contractors and engineers should exercise care to make certain that the conditions that existed for the trial mixes continue to exist during construction. If any conditions change, such as cementitious materials, aggregate source, or ambient temperature, new trial mixes should be conducted to ensure the proper slump loss is achieved (O’Neill and Reese 1999). For example, the use of different cementitious materials, whether it be using the same type of cement from a different company or change in cement type all together, may increase or decrease the rate of slump loss depending on the fineness and chemical composition. Figure 3.15 shows that for constant mixture proportions, a change in cement brand can increase or decrease the rate of slump loss over time. Reconstruction of the slump loss graph versus time is particularly important when the laboratory temperatures do not reflect field

temperatures, which strictly speaking the concrete temperature itself is the most important. If the field temperatures are higher than laboratory temperatures, the slump loss graph is misleading since slump loss is accelerated in hot weather conditions. O'Neill and Reese (1999) report that an increase in 18 deg. F will increase the rate of slump loss by a factor of approximately 2.

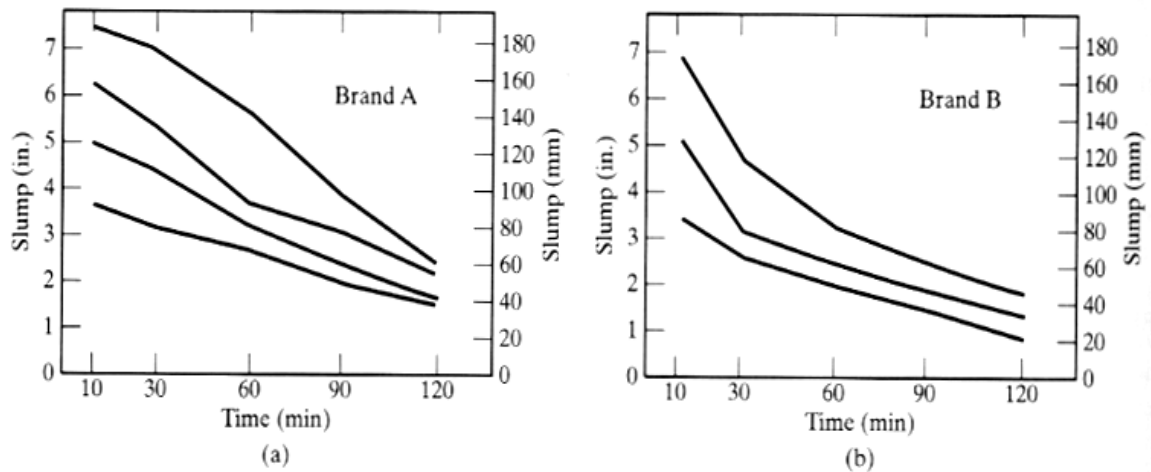


Figure 3.15 – Slump Loss at 70°F for Two Different Brands of Type I Cement (Mindess et al. 2003)

O'Neill and Reese (1999) determined that 4 inches after 4 hours would be appropriate because ordinarily this is the maximum amount of time that is required for concrete placement. However, drilled shafts today are being constructed with larger diameters at deeper depths that require long periods of time for concrete placement. Long periods for concrete placement may also be required where the construction site is difficult to access or unforeseen construction delays occur. Unfortunately, many state DOT's still use this specification that routinely calls for a slump of 4 inches be maintained after 4 hours. For that reason, Brown (2004) suggests that based on his

experience and observations that this recommendation is not adequate for many conditions. For example, if contractual documents require a contractor to maintain 4 inches of slump after 4 hours, but the drilled shaft requires 6 hours for concrete placement, the requirement of 4 inches after 4 hours will be insufficient for that application. Although the contractor may have supplied a mixture that maintained 4 inches of slump after 4 hours, by the time concrete placement is complete the workability of the concrete mixture has diminished greatly below 4 inches, which may produce undesirable results. Brown (2004) proposes that the concrete mixture maintain a high workability, a slump loss of no more than 2 inches, for the duration of the concrete placement no matter what that period may be. In that case, not only will the concrete maintain high workability for the duration of the concrete placement, it will also prevent two very dissimilar fluids from interacting.

Case Study 1 (after Brown 2004)



Figure 3.16 - Shaft Defects due to the Loss of Workability (left), After Removal of Surface Flaws for Repairs (photograph courtesy of Dr. Dan Brown)

In this example, drilled shafts were used to support individual columns for a bridge over a lake in the southwest United States. The upper portions of the shafts were

formed by using removable casing that was extended through the lake. It can be seen from Figure 3.16 that the rebar cage had reasonably large openings that typically measured 8 inches between the transverse and longitudinal reinforcement. In this instance the rebar cage was not restrictive to concrete flow. The concrete was placed using a gravity-fed tremie. Each shaft required 5 to 6 concrete trucks with each shaft taking 4 to 6 hours to complete the concrete pour.

After the removal of the forms, the shaft appeared to have weak pockets of cemented materials. The cemented material seemed to be mortar-like with no presence of coarse aggregate within the pockets. The pockets were easily chipped away using a hammer revealing large voids within the shaft. Figure 3.16 illustrates these weak pockets before they were chipped away for repairs (left), and the voids that were present after the mortar-like material was removed (right). After close examination of the shafts it was determined that the concrete did not maintain sufficient workability for the duration of the pour during the hot summer months. As the concrete moved up in the shaft, the tremie would be lifted from the bottom of the shaft, but always maintained at least 7 feet below the surface of the concrete. However, the previously placed concrete began to lose its workability and became stiff within the shaft. The fresh concrete placed in the shaft through the tremie pipe that was below the surface of this stiff concrete erupted through the stiff concrete rather than lifting the concrete in one uniform layer. When this occurred, the debris that had been riding on top of the column of concrete became entrapped on the outside of the rebar cage causing the surface flaws.

Case Study 2 (after O'Neill and Reese 1999)



***Figure 3.17 - Shaft Defects due to the Loss of Workability from Construction Delays
(O'Neill and Reese 1999)***

In this example, concrete was being placed by a gravity-fed tremie with the concrete being delivered to the tremie by means of pumping. Figure 3.17 reveals that rebar cage had relatively large openings that were not particularly resistive to concrete flow. While concrete placement was taking place there was an interruption in the concrete supply. The interruption in concrete delivery allowed the previously placed concrete to become stiff within the shaft. When the concrete placement resumed the fresh concrete that was introduced below this now stiff concrete erupted through the stiff concrete. As a result, the debris that was riding on top of the rising column of concrete became entrapped on the outside of the rebar cage. As the entrapped debris was removed for repair, large voids within the shaft were revealed as shown in Figure 3.17.

Case Study 3 (after Gerwick 2004)

Gerwick (2004) illustrates an instance where several thousand yards of concrete was to be tremie placed. The night supervisor was rushing to complete the job in record time. In an effort to speed up the concrete placement, the night supervisor opened the concrete buckets rapidly so that the tremie pipe can be moved up at a rapid rate to get the concrete to flow faster. However, when plugging of the tremie pipe occurred, the night supervisor made aggressive attempts to free the plugs by raising and dropping the tremie. Although the project was completed rapidly, a subsequent diver investigation revealed that seams of gravel and trapped pockets of laitance were buried under sound structural concrete. By extracting the tremie pipe out of the concrete to restart the flow again, the night supervisor consequently entrapped the laitance and debris that was riding on top of the column of concrete.

Case Study 4 (after Brown 2004)

In this example, a drilled shaft was constructed through approximately 40 feet of soil and socketed into approximately 10 feet of underlying rock formation using casing for the full depth. The casing was utilized to allow downhole visual inspection of the bottom of the shaft. The drilled shaft was to be load tested using an Osterberg cell that was placed at the base of the rock socket. After inspection was completed, the Osterberg cell and rebar cage was placed in the shaft, concrete was then placed in the rock socket and the casing removed. After the concrete was allowed to cure for some period, the shaft was load tested using this Osterberg cell. The Osterberg cell mobilized 112.4 kips of side shear resistance. This side shear resistance was found to be only a small fraction

of what was expected. For comparison, another drilled shaft was constructed in the same manner. However, this time the wet-hole method was utilized without casing into the rock. The concrete was then placed into the drilled shaft using a tremie pipe. After the concrete was allowed to cure for some period, the shaft was load tested and the Osterberg cell was found to mobilize over 2248 kips of side shear resistance.

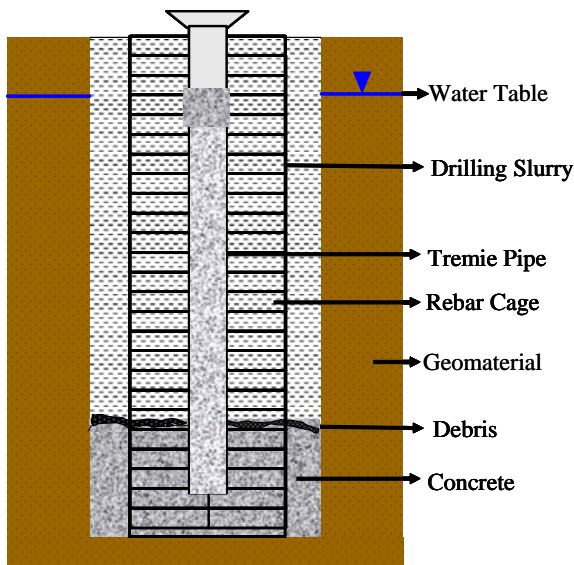
It can be seen from the information provided above that the two different methods of placement provided very different results. It was concluded that the time required for removal of the casing after concrete placement allowed the concrete to lose its workability to a point that the concrete was essentially “slip formed” into an oversized hole within the rock socket. As a result, the concrete did not provide sufficient lateral pressure against the rock socket when the casing was removed resulting in low side shear resistance. It was also believed that because the concrete could not provide sufficient lateral pressure on the rock socket that the debris behind the casing could not be displaced when the casing was removed, which consequently could have contaminated the bond between the concrete and rock.

3.3 COMPATIBILITY BETWEEN CONGESTED REBAR CAGES AND CONCRETE

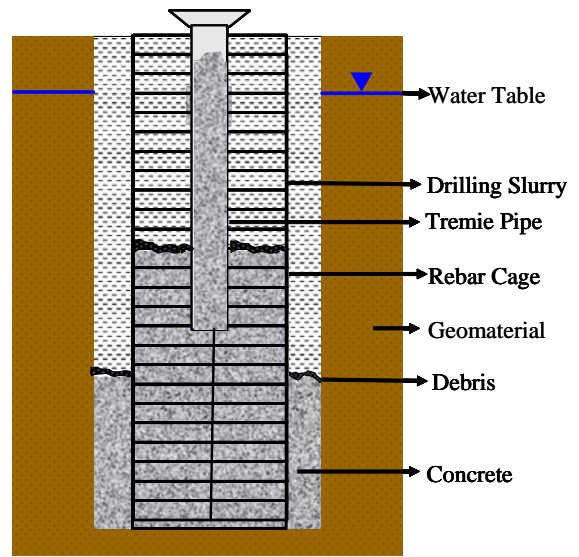
Improved equipment and appropriate construction techniques have allowed contractors to construct very large diameter drilled shafts at great depths. These large diameter shafts have advantages for structures that experience large lateral and overturning loads that are produced by seismic loads, vessel impacts, and wind. Single large drilled shafts produce smaller footprints than piled footings, a benefit in terms of constructability when working in congested construction sites or nearby existing

structures (Brown 2004). As a result, designers and engineers have increasingly designed and specified large diameter shafts. The use of larger diameter shafts that are designed for large bending moments require high amounts of reinforcement bars to be placed within the shaft. Consequently, the rebar cages have become progressively more congested and resistive to concrete flow. The addition of numerous access tubes for integrity testing has also lead to increased congestion in the rebar cages. Although these large diameter shafts have numerous advantages; problems from resistive rebar cages can occur in the following ways:

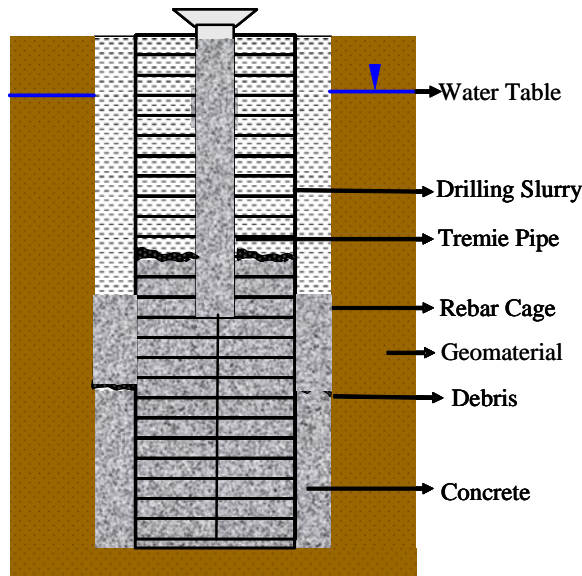
PROBLEM NO. 1- When closely spaced reinforcement bars are utilized, there is an increased probability that debris will be entrapped in the annular space outside the rebar cage. The debris is entrapped when the lateral flow of the concrete is significantly impeded, which Gerwick (2004) describes as screening of the concrete, resulting in an elevation difference between the inside and outside of the rebar cage. As a result, any debris that is accumulated on top of the rising column of concrete has a natural tendency to slough off into the annular space outside the rebar cage. As additional fresh concrete is placed into the shaft, the fresh concrete will eventually flow laterally through rebar cage entrapping the debris as shown in Figure 3.18. Figure 3.19 illustrates the elevation difference due to screening of the concrete flow, while Figure 3.20 shows shaft defects that can occur when the concrete flow is impeded by heavily congested rebar cages.



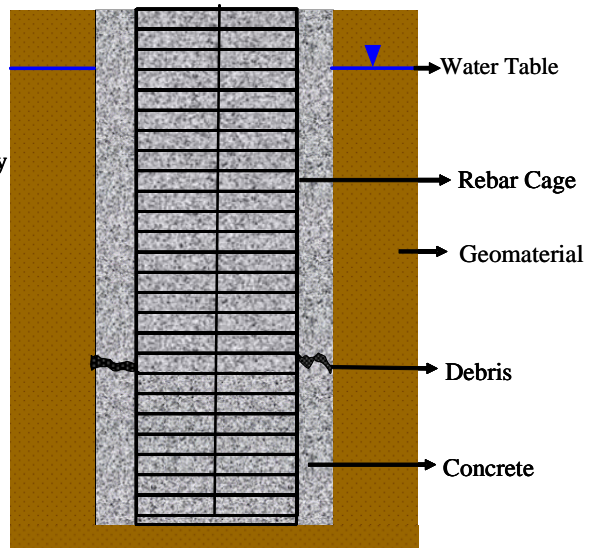
(A) Fresh concrete being placed within the shaft.



(B) Heavily congested rebar cage begins to screen the concrete causing an elevation difference between the inside and outside rebar cage.



(C) Fresh concrete placed in the shaft flows laterally entrapping debris.



(D) Completed shaft with entrapped debris due to heavily congested rebar cage.

Figure 3-18 Screening of the Concrete due to Heavily Reinforced Rebar Cages



Figure 3.19 - Elevation Difference between the Inside and Outside of a Rebar Cage due to Screening of the Concrete Flow (photograph courtesy of Dr. Dan Brown)



Figure 3.20 – Shaft Defects due to the Screening of the Concrete Flow (photograph courtesy of Dr. Dan Brown)

PROBLEM NO. 2 – Even if tremie placement with clean slurry or placement by freefall is utilized; the concrete flow can become impeded to such an extent that large voids form outside the rebar cage. This can occur when the reinforcement bars are so closely spaced that there is interlocking and bridging of the aggregate at the vicinity of the rebar cage. Interlocking and bridging of the aggregate may be increased when crushed stones are utilized or when the aggregate size is too large for the reinforcement spacing. In other cases, the flow may become impeded to a standpoint that the lateral stress imposed by the concrete on the bearing stratum is diminished.

The rebar cages for drilled shaft foundations consist of longitudinal bars that are distributed evenly around the outside and transverse (ties or spirals) reinforcement that is placed around the longitudinal bars. The FHWA guidelines recommend that the clear spacing between bars be at least 5 times the maximum size aggregate (O'Neill and Reese 1999). Gerwick (2004) proposes that the largest possible bars be used, and spaced 3 to 4 times the maximum size aggregate. Brown (2004) expresses the fact that he has routinely seen these recommendations violated in practice. Brown (2004) goes on to suggest that these recommendations are sometimes disregarded where seismic loads are significant. When seismic conditions exist, designers may use tight spiral confinement with a small pitch. The FHWA guidelines would advise the use of pea sized gravel in such circumstances (O'Neill and Reese 1999). The use of pea-sized gravel gives the mixture enhanced workability over crushed aggregate and decreases the probability of bridging of the aggregate at the vicinity of the rebar cage. Brown (2004) suggests it is common practice that agencies allow the use of pea gravel, but does not specifically require the use of pea gravel in contractual documents. Since pea gravel mixtures are more expensive on

a material basis, in many cases contracts may be allotted to contractors that may utilize a less expensive mix that uses crushed stones. The result of such practice is that a concrete mixture may be chosen based on the lowest cost, rather than the one that is most appropriate for the conditions. Designers should consider the consequences of tight reinforcement spacing and emphasize the workability in construction material so that constructability problems are minimized.

Case Study 5 (after Brown 2004)

Single 13 foot diameter shafts were to be used to support oval shaped columns for a bridge in the western United States. The shafts were to be socketed through overlaying alluvial sandy soil into sandstone. The contractor cased through the overlaying sandy soil with temporary casing. In order for the rebar cage in the shaft to match the shape of the column, designers used two rebar cages in which the two reinforcement cages overlap each other in a form of a fat figure 8 as shown in Figure 3.21. In this application, the concrete mixture had to flow through two rebar cages that were heavily congested due the transverse reinforcement, which was rather restrictive to concrete flow.

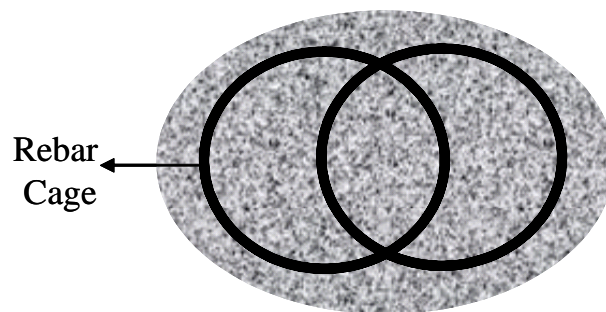


Figure 3.21 –Oval Shaped Column with Figure 8 Rebar Cage (not to scale)

Subsequent integrity testing indicated large anomalies around the perimeter of several shafts. Access shafts were constructed along side the drilled shafts where the anomalies were thought to be present. The examination of the shafts revealed that large pockets of sand were entrapped where the two rebar cages overlapped. After removal of the sand pockets, large voids remained in the outer perimeter of the shaft as shown in Figure 3.22. Coring samples indicated that sound concrete with consistent compressive strengths within the center of the shaft, but unsound concrete with erratic compressive strengths was found to be around the perimeter of the shafts.



Figure 3.22 – Shaft Defect due to Double Reinforcement Cages (photograph courtesy of Dr. Dan Brown)

Case Study 6 (after Brown 2004)

In this example test shafts were constructed for a new bridge in the eastern United States. The test shafts were 8 feet in diameter and up to 160 feet deep with a rebar cage that consisted of heavy longitudinal reinforcement and spiral reinforcement at a 3.5 inch pitch. The concrete mixture incorporated the use of crushed stone with a maximum size aggregate of ½ inch and a slump of 8 inches. As the concrete was being tremie placed, measurement and observations were made on the concrete behavior (Camp et al. 2002). The measurements taken indicated that a head difference between the inside and outside of the rebar cage of at least 4.5 feet. Although small aggregate and a high slump concrete mixture were used in this project, observation from the concrete behavior showed there was still a potential for debris to become entrapped in annular space outside the rebar cage. Therefore, designers and engineers should be cautious in such circumstances to ensure that the probability of entrapped debris is reduced, which may include the use of rounded pea gravel.

3.4 SEGREGATION AND BLEEDING

In Section 3.2 it was stated that drilled shaft concrete should have excellent workability so that it can readily flow through the tremie, rebar cage, and the annular space between the rebar cage and borehole wall. In addition to having high workability, drilled shaft concrete should exhibit sufficient cohesiveness to prevent segregation of the concrete mixture. Segregation can be described as the separation of the constituents of a heterogeneous mixture so that the mixture is no longer uniform (Neville 1996). The main

factors that contribute to the segregation of concrete mixture are listed below: (Mindess et al. 2003)

- Larger maximum particle size over 1 inch and proportions of larger particles
- High specific gravity of the coarse aggregate compared to that of the fine aggregate
- A decreased amount in fines (sand or cement)
- Changes in the particle shape away from well-rounded particles to crushed stones
- Mixes that are too wet or dry

In the case of drilled shaft concrete, the probability of segregation is increased due to the fact that dropping concrete from considerable heights by free fall or tremie placement, changes in direction of flow, discharging against obstacles, and considerable amount of handling all encourage segregation (Neville 1996). In drilled shaft construction, segregation by handling may if the concrete must be delivered to a remote location without the continuous mixing of the concrete mixture for the entire time. Furthermore, any delay in concrete delivery during tremie placement can result in segregation within the concrete column inside the tremie, which can lead to plugging of the tremie and inclusions of non-uniform concrete within the shaft (Brown 2004). Since these circumstances mentioned above frequently arise in drilled shaft construction, it is pertinent that designers ensure that a highly cohesive mixture with proper gradation of aggregate is used. The use of smaller-rounded aggregate and a highly cohesive mixture will help to prevent sedimentation of aggregate particles in a concrete mixture (Neville 1996, and Mindess et al. 2003).

Bleeding is commonly regarded as a special form of segregation. It is defined as the upward movement of mixing water to the surface of freshly placed concrete (Neville

1996). Bleeding can be caused by the settlement of aggregate particles, and the inability of the concrete to hold the mixing water. Since water has the lowest specific gravity, it segregates from the concrete mixture by rising to the surface of the freshly placed concrete (Mindess et al. 2003). Although some bleeding is unavoidable and normal for good concrete, a significant amount of bleeding can result in inferior concrete. This is true especially for tall elements such as columns and drilled shaft foundations. As the bleed water moves upward to the surface of the shaft, the water-to-cementitious materials ratio in the lower portion of the shaft is decreased, but the bleed water trapped in the upper portion of the shaft causes an increase in the water-to-cementitious ratio, which may result in a reduction in strength (Neville 1996).

The rising bleed water can also become trapped on the underside of coarse aggregate and reinforcement; thus, resulting in larger interfacial transition zones and loss of bond between the reinforcement and concrete as shown in Figure 3.23. Furthermore, bleed water can travel upwards along the surface of casings forming a channel due to imperfections in the casing. Neville (1996) reports that a preferred channel is formed resulting in surface streaking and distinct localized channels as shown in Figures 3.24 and 3.25. In Figures 3.24 and 3.25, drilled shafts were cast through a lake in the underlying soil using removable casing. After the removable casing was removed, it was observed that bleed channels and surface streaks were formed along the outer perimeter of the shaft due to bleed water. In other cases, vertical bleed channels are formed in the interior of the shaft. These vertical bleed channels commonly form along the longitudinal reinforcement resulting in loss of bond between the reinforcement and concrete.

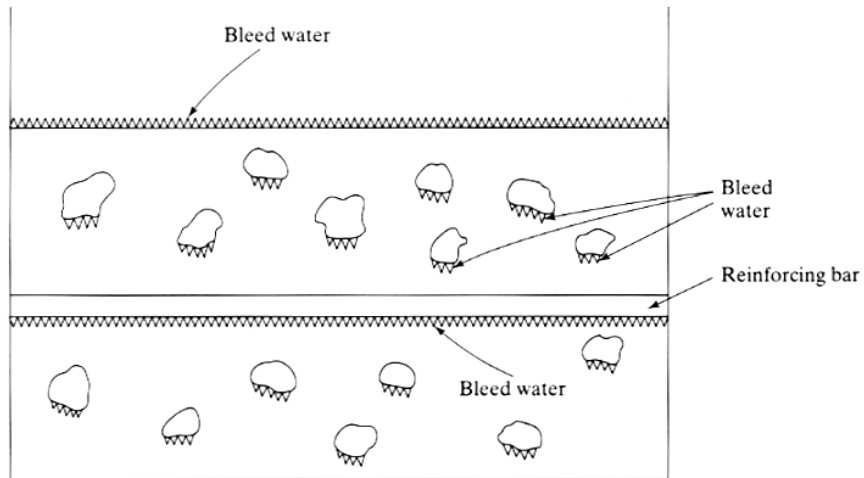


Figure 3.23 – Illustration of Bleeding in Freshly Placed Concrete (Mindess et al. 2003)



Figure 3.24 – Example 1 of Bleed Channels and Surface Streaks due to Bleed Water Traveling along the Casing (photograph courtesy of Dr. Dan Brown)



Figure 3.25 – Example 2 of Bleed Channels and Surface Streaks due to Bleed Water Traveling along the Casing (photograph courtesy of Dr. Dan Brown)

This high generation of bleed water can lead to increased porosity, reduced strength, increased permeability, reduced durability, and plastic shrinkage cracks. Therefore, it is necessary to control or limit the amount of bleed water generated. This is especially true for large shafts at deep depths, where temporary casing is utilized, and when the wet-hole method is used in low-permeable soils. In such cases, the generated bleed can not escape laterally as in highly permeable soils. As a result, bleed water will escape vertically through bleed channels. Under these circumstances, the use of high water-to-cementitious ratio concrete mixtures with high water contents may lead to low cohesive concrete mixtures that promote both segregation and bleeding. In order to reduce the amount of bleeding Mindess et al. (2003) and Neville (1996) suggest that the following steps be taken to reduce the amount of bleed water generated:

- Increase the cement fineness or by using other finely divided supplementary cementitious materials
- Through air entrainment, which is very effective
- By reducing the water content or water-to-cementitious ratio
- Presence of an adequate proportion of very fine aggregate particles, especially less than the #100 sieve

Case Study 7



Figure 3.26 - Shaft Defect due to Bleed Water Traveling along the Casing (TxDOT)

In this example, drilled shafts were used to support columns over a bridge in the southwest United States. The drilled shafts were cast through the lake into the underlying soil that consisted of sedimentary rock using approximately 60 feet of removable casing. Each shaft was approximately 6 feet in diameter and 80 feet deep. After the removable

forms were removed, inspectors noticed bleed channels and surface streaks had formed along the outer perimeter of the shaft.

The use of removable casing and considering the fact that the shaft was placed into sedimentary rock forced the bleed water to travel vertically creating bleed channels and surface streaks as shown in Figure 3.26. It can be determined from looking at Figure 3.26 that the creation of bleed channels may result in a reduction in durability and increased permeability. Careful attention must be exercised to ensure that bleeding is reduced by incorporating actions previously stated.

3.5 SUMMARY AND CONCLUSIONS

- Recently developed techniques in integrity and load testing have provided engineers and contractors with insight to problems that are associated with materials and construction practices that have lead to defects or less than optimal performance in drilled shaft foundations.
- Some of the most common issues that comprise the quality of drilled shaft foundations due to drilled shaft concrete come from the failure to consider one or more of the following:
 1. Retained workability of the concrete mixture for the duration of the pour
 2. Blockage of the coarse aggregate due to congested rebar cages
 3. Segregation and bleeding of the drilled shaft concrete
- In drilled shaft construction, full compaction or consolidation of a concrete mixture must be achieved without the use of external energy.
- Workability is one of the most important characteristics for drilled shaft concrete.

- Another important aspect of drilled shaft concrete in terms of workability is the consideration of the aggregate type and gradation.
- When tremie placement or casing is utilized it is not only important to have sufficient workability initially, but it is also critical to maintain the workability for the duration of the pour.
- If workability is not maintained for the duration of the pour there is a probability that debris can become entrapped causing structural defects within the shaft.
- To ensure that proper workability and slump retention is achieved, trial mixes should be conducted with the cementitious materials, aggregates, and additives that will be used for a particular application.
- When closely spaced reinforcement bars are utilized the lateral flow of the concrete is significantly impeded resulting in an elevation difference and interlocking and bridging of the aggregate at the vicinity of the rebar cage. Debris accumulated on top of the rising column of concrete has a possibility of becoming entrapped on the outside of the rebar cage.
- Drilled shaft concrete should exhibit sufficient cohesiveness to prevent segregation of the concrete mixture.
- Rising bleed water can become trapped on the underside of coarse aggregate and reinforcement; thus, resulting in larger interfacial transition zones and loss of bond between the reinforcement and concrete.
- Bleed water can travel upwards along the surface of casings forming a preferred channel resulting in surface streaking and distinct localized channels resulting in loss of bond between the reinforcement and concrete.

CHAPTER 4

LABORATORY TESTING PROGRAM AND MATERIALS

4.1 INTRODUCTION

The objective of this research project is to evaluate the use of self-consolidating concrete as a viable material to be used in drilled shaft construction. The laboratory testing program developed will examine the difference between ordinary drilled shaft concrete (ODSC) and self-consolidating concrete (SCC) for both fresh and hardened properties. The fresh properties include filling ability, passing ability, segregation resistance, workability over time, bleeding characteristics, and setting. The hardened properties include the comparison of the compressive strength, elastic modulus, permeability, and drying shrinkage. Based on the results of the laboratory testing program, mixture proportions will be recommended for further evaluation during the construction of full-scale shafts in South Carolina.

4.2 REQUIREMENTS FOR ODSC AND SCC MIXTURES

According to SCDOT specifications (2003), concrete for drilled shaft construction should be Class 4000 DS. The specification for Class 4000 DS states that the concrete mixture shall meet the following criteria:

- Minimum Cement per cubic yard.....625 lbs.
- Slump.....7-9 inches
- Maximum water-to-cementitious ratio....0.43
- 28-Day minimum compressive strength...4000 psi

- Air entrainment.....not required
- Nominal coarse aggregate size.....3/4 inch
- No. 67 aggregate gradationrequired

Since a proposed field study will be conducted in South Carolina, all ordinary drilled shaft concrete (ODSC) mixtures prepared in the laboratory shall also conform to the above criteria. However, due to the nature of this research the SCC mixtures will not conform to the above criteria set forth by the SCDOT with the exception of the required 28-day minimum compressive strength of 4,000 psi. Instead, the quality control limits for the SCC mixtures were based on past research and careful consideration of the drilled shaft construction issues discussed in Chapter 3.

Yao and Gerwick (2004) report that slump flow value requirements for drilled shafts applications typically range from 14 to 18 inches. In order to provide a concrete mixture with an increase in workability compared to the typical requirements provided above, it was determined that no SCC mixture should exhibit a slump flow less than 18 inches at placement. Research conducted at Auburn University by Hodgson (2003) indicates that when SCC is used in drilled shaft applications, a slump flow of approximately 24 inches can provide sufficient workability while showing limited signs of segregation. Based upon this literature, it was concluded that a slump flow of 18 inches would provide an increase in workability compared to ODSC and displace the drilling slurry upward in one uniform horizontal layer. It was further determined that the upper slump flow value should be limited to 24 inches in order to prevent severe segregation, and slump flow values over 24 inches would not be needed to provide the necessary workability. Moreover, a VSI rating of 1 or less was established in order to limit possible segregation of the concrete mixture during or after placement. It must be

noted that mixture proportions for the base line SCC mixture utilized in Phases I-IV (3:41-48-FA) were based on recommendations provided by Su et al. (2001) “*A Simple Design Method for Self-Compacting Concrete*”.

All concrete mixtures prepared in the laboratory shall meet the ACI 318 (2002), “*Building Code Requirements for Reinforced Concrete*”, recommendations that specifies that the concrete mixtures should be proportioned to provide an average compressive strength (f'_{cr}) which is higher than the required strength (f'_c). When adequate data are not available to establish a standard deviation it is recommended that the specified compressive strength (f'_c), when ranging from 3,000 to 5,000 psi, be increased by 1,200 psi. Therefore, all concrete mixtures should have a critical average compressive strength (f'_{cr}) of no less than 5,200 psi at 28-days to be considered acceptable.

4.3 LABORATORY TESTING PROGRAM

The laboratory testing program was developed to investigate the use of self-consolidating concrete as a viable material to be used in drilled shaft construction. This research was separated into five separate phases to evaluate or compare an aspect of the concrete’s performance. In this research project the following five phases were evaluated:

- Effect of Type and Dosage of HRWRA
- Effect of Retarder Dosage
- Appropriate SCC Mixing Procedure
- Selection of SCC Properties
- Methods to Modify the Viscosity of SCC Mixtures

4.3.1 Phase I – Effect of Type and Dosage of HRWRA

In view of the fact that the recommended concrete mixture will eventually be used for a full-scale field study, it is essential to assess the effect of continuous mixing imposed by a ready mix truck during transportation. Experience has indicated the slump or slump flow will decrease with continuous mixing. Therefore, the primary objective of Phase I was to determine the type and approximate dosage of high-range water reducing admixture (HRWR) required to produce the necessary slump flow characteristics following some period of mixing time.

Preliminary investigations indicated that the approximate transportation time from the batch plant located in Marion, South Carolina to the proposed field site located 1.25 miles southeast of Nichols, South Carolina would be approximately 30 minutes. Upon arrival at the field site, the slump flow should be within the quality control limits of 18 to 24 inches with a VSI rating of 1 or less. Batch sizes of two cubic feet with the mixture proportions shown in Table 4.1 were utilized for this phase of the research. A slump flow test was performed on each concrete mixture directly after the completion of the mixing procedure, which would represent the slump flow at the batch plant. The concrete mixture would subsequently be mixed for an additional 30 minutes to simulate the transportation time. Afterwards, the slump flow test was performed once more, which represented the slump flow at the job site. Figure 4.1 shows the flow chart used for Phase I of this research project.

Table 4.1 - Concrete Mixture Proportions for Phase I

Item	SCC Mixture
Coarse Aggregate (No. 67) (lb/yd ³)	1082
Coarse Aggregate (No. 789) (lb/yd ³)	394
Fine Aggregate (lb/yd ³)	1366
Water (lb/yd ³)	306
Type I Cement (lb/yd ³)	500
Class F Fly Ash (lb/yd ³)	250
Target Air (%)	2
High-Range Water Reducer (PCE) (oz/cwt)	8 to 12
Retarder (oz/cwt)	8
Viscosity Modifying Admixture (oz/cwt)	2

PHASE I

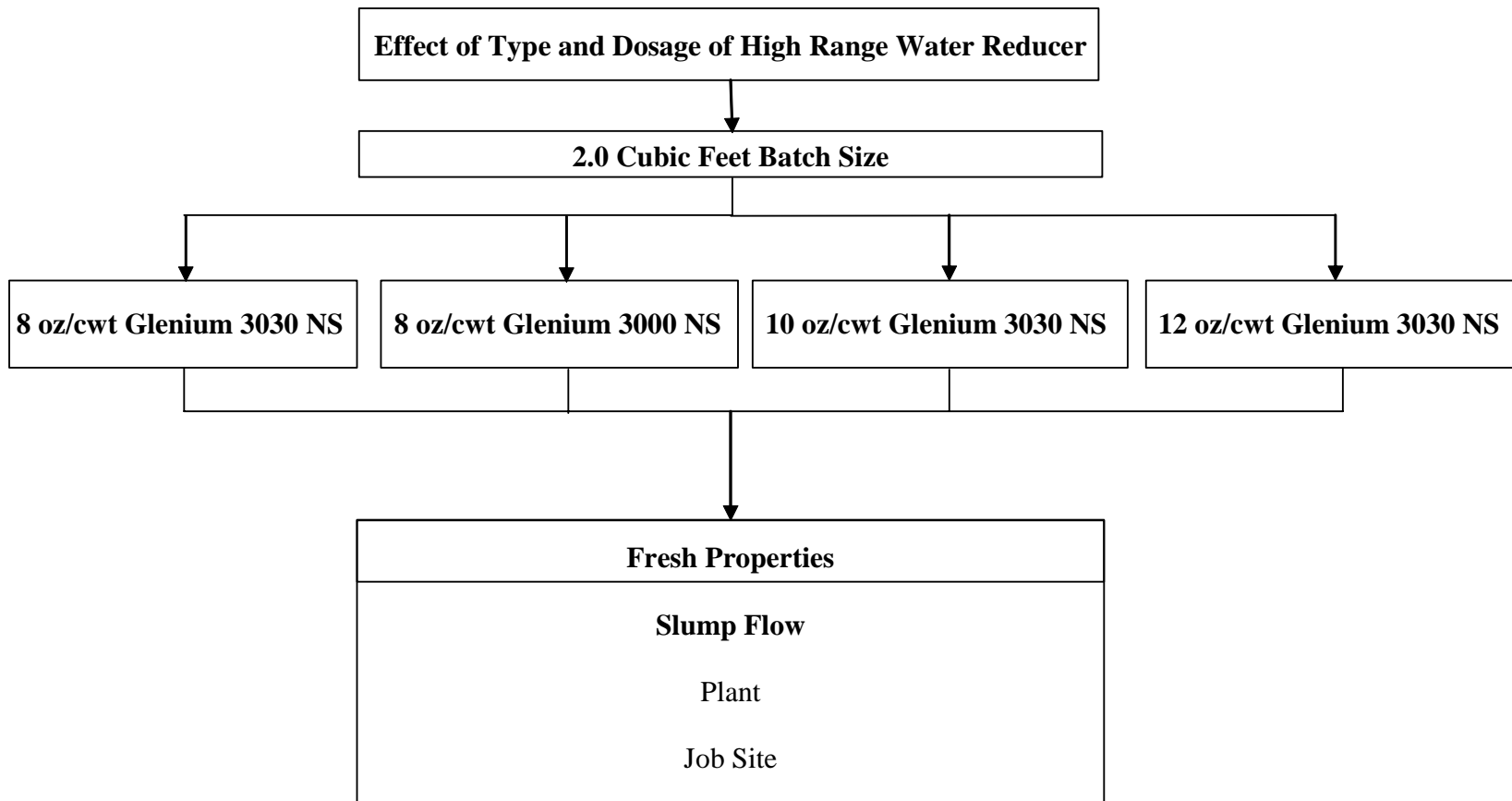


Figure 4.1 – Flow chart for Phase I

4.3.2 Phase II – Effect of Retarder Dosage

When tremie placement or temporary casing is utilized for drilled shaft foundations it is not only important to have sufficient workability initially, but it is also critical to maintain the workability for the duration of the pour. Controlled setting of the concrete mixture is necessary to allow for any construction delays in concreting, and to allow the temporary casing to be removed after concreting is completed. In most cases, retarding admixtures are used to provide the controlled setting that is necessary to complete the construction sequence.

The primary objective of Phase II was to determine the effect of retarding admixtures on the retained workability over some duration of time. Batch sizes of two cubic feet with the mixture proportions shown in Table 4.2 were used for this phase of the research project. Therefore, only the effect of the delayed hydration due to the retarder dosage was examined in the phase. Slump flow tests were performed over time as well as setting tests for each batch. Figure 4.2 shows the flow chart used for this phase of the research project.

Table 4.2 - Concrete Mixture Proportions for Phase II

Item	SCC Mixture
Coarse Aggregate (No. 67) (lb/yd ³)	1082
Coarse Aggregate (No. 789) (lb/yd ³)	394
Fine Aggregate (lb/yd ³)	1366
Water (lb/yd ³)	306
Type I Cement (lb/yd ³)	500
Class F Fly Ash (lb/yd ³)	250
Target Air (%)	2
Retarder (oz/cwt)	0 to 8
High-Range Water Reducer (PCE) (oz/cwt)	10
Viscosity Modifying Admixture (oz/cwt)	2

PHASE II

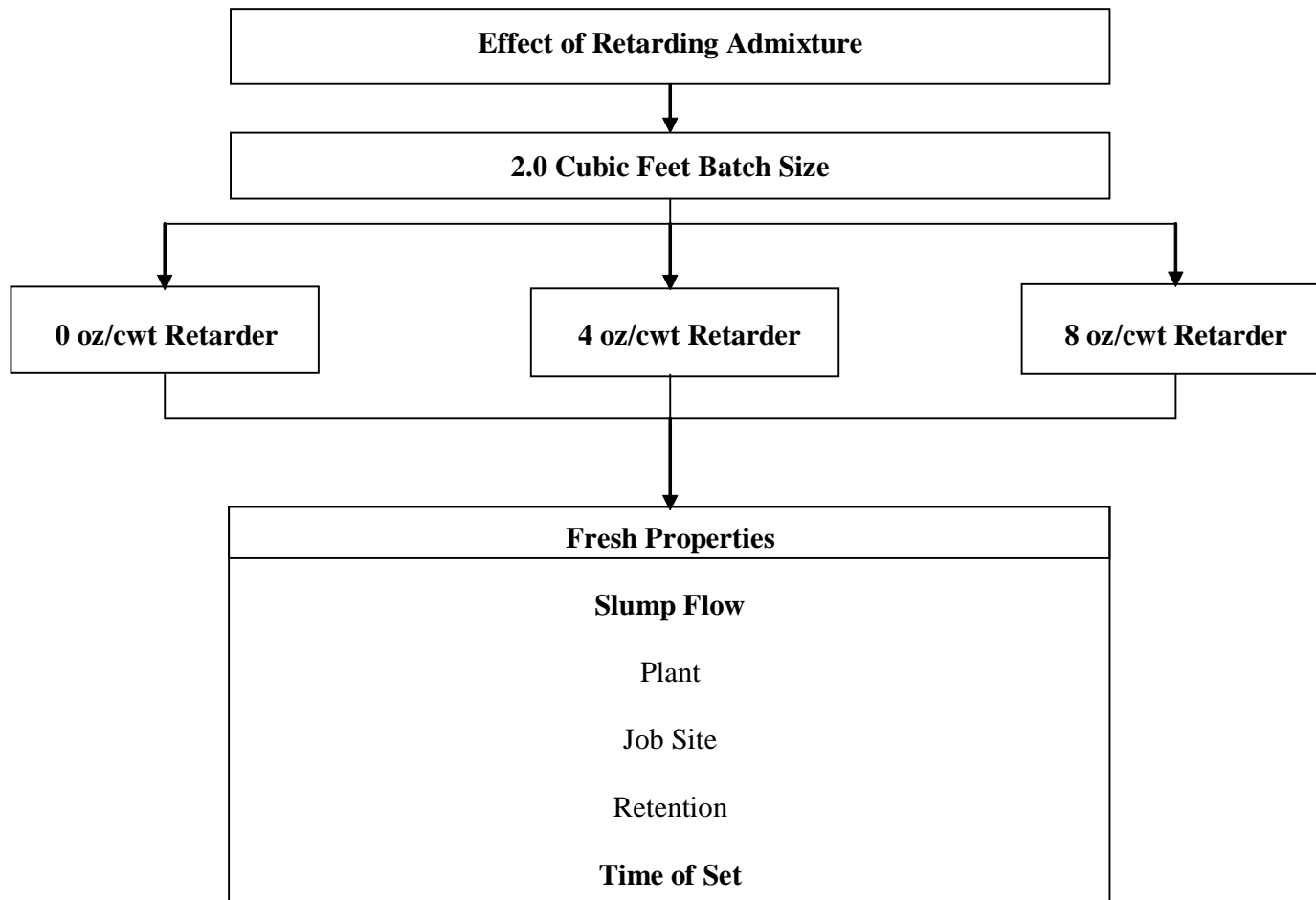


Figure 4.2 – Flow chart for Phase II

4.3.3 Phase III – Appropriate SCC Mixing Procedure

The purpose of Phase III was to determine an appropriate SCC mixing procedure to be used throughout the remaining research project as well as the field study. It should be noted that the standardized mixing procedure provided by ASTM C 192 (1998) is not appropriate for SCC. Two suggestions were provided by either chemical admixture representatives or ready mix concrete suppliers as to when the HRWR admixture should be added. One suggestion indicated that adding the HRWR admixture before the addition of the cementitious materials may improve the effectiveness of the HRWR admixture. The other suggestion preferred that the HRWR admixture be added after the addition of the cementitious materials so that a “water slump” can be obtained. The purpose of this water slump is to give an indication of the concrete’s consistency due to the net mixing water alone. Furthermore, the water slump can be an indicator to determine if the moisture corrections performed on the aggregate was correct. Thus, two mixing procedures were developed to determine the effect of timing of HRWR admixture addition. Batch sizes of two cubic feet with the mixture proportions shown in Table 4.3 were mixed according to the mixing procedures listed below. In addition, slump flow tests were performed over time to determine the effect of the mixing process on the slump flow retention. Figure 4.3 shows the flow chart used for this phase of the project.

Table 4.3 – Concrete Mixture Proportions for Phase III

Item	SCC Mixture
Coarse Aggregate (No. 67) (lb/yd ³)	1082
Coarse Aggregate (No. 789) (lb/yd ³)	394
Fine Aggregate (lb/yd ³)	1366
Water (lb/yd ³)	306
Type I Cement (lb/yd ³)	500
Class F Fly Ash (lb/yd ³)	250
Target Air (%)	2
Retarder (oz/cwt)	8
Viscosity Modifying Admixture (oz/cwt)	2

Mixing Procedure 1 – Early Addition of HRWRA

1. Add 50% of mixing water into the concrete mixer.
2. Add coarse and fine aggregates.
3. Add any retarding admixtures onto aggregates.
4. Mix for 1 minute.
5. Add the rest of the mixing water.
6. Add HRWR while concrete is mixing.
7. Mix for 2 minutes.
8. Stop the mixer and add cementitious materials.
9. Add any VMA while concrete is mixing.
10. Run the mixer for 3 minutes.
11. Rest for 3 minutes.
12. Run the mixer for an additional 2 minutes.
13. Stop the mixer and take a slump or slump flow reading. This represents testing at the batch plant.
14. Run the mixer for 50 minutes. This accounts for transportation time that will be required.

15. Stop the mixer and take a slump or slump flow reading. This represents the testing at the job site.
16. Proceed to make all fresh and hardened specimens for testing.

Mixing Procedure 2 – Delayed Addition of HRWRA

1. Add 80% of the mixing water into the mixer.
2. Place the coarse and fine aggregate into the mixer.
3. Add any retarding admixtures onto aggregates.
4. Mix for 1 minute.
5. Stop the mixer and add cementitious materials.
6. Add the rest of the mixing water.
7. Add any VMA while the concrete is mixing.
8. Mix concrete for 2 minutes.
9. Stop the mixer and take a water slump reading.
10. Add any water reducing admixtures.
11. Run the mixer for 3 minutes.
12. Rest for 3 minutes.
13. Run the mixer for an additional 2 minutes.
14. Stop the mixer and take a slump or slump flow reading. This represents testing at the batch plant.
15. Run the mixer for an additional 50 minutes. This accounts for the transportation time that will be required.
16. Stop the mixer and take a slump or slump flow reading. This represents testing at the job site.
17. Proceed to make all fresh and hardened concrete specimens for testing.

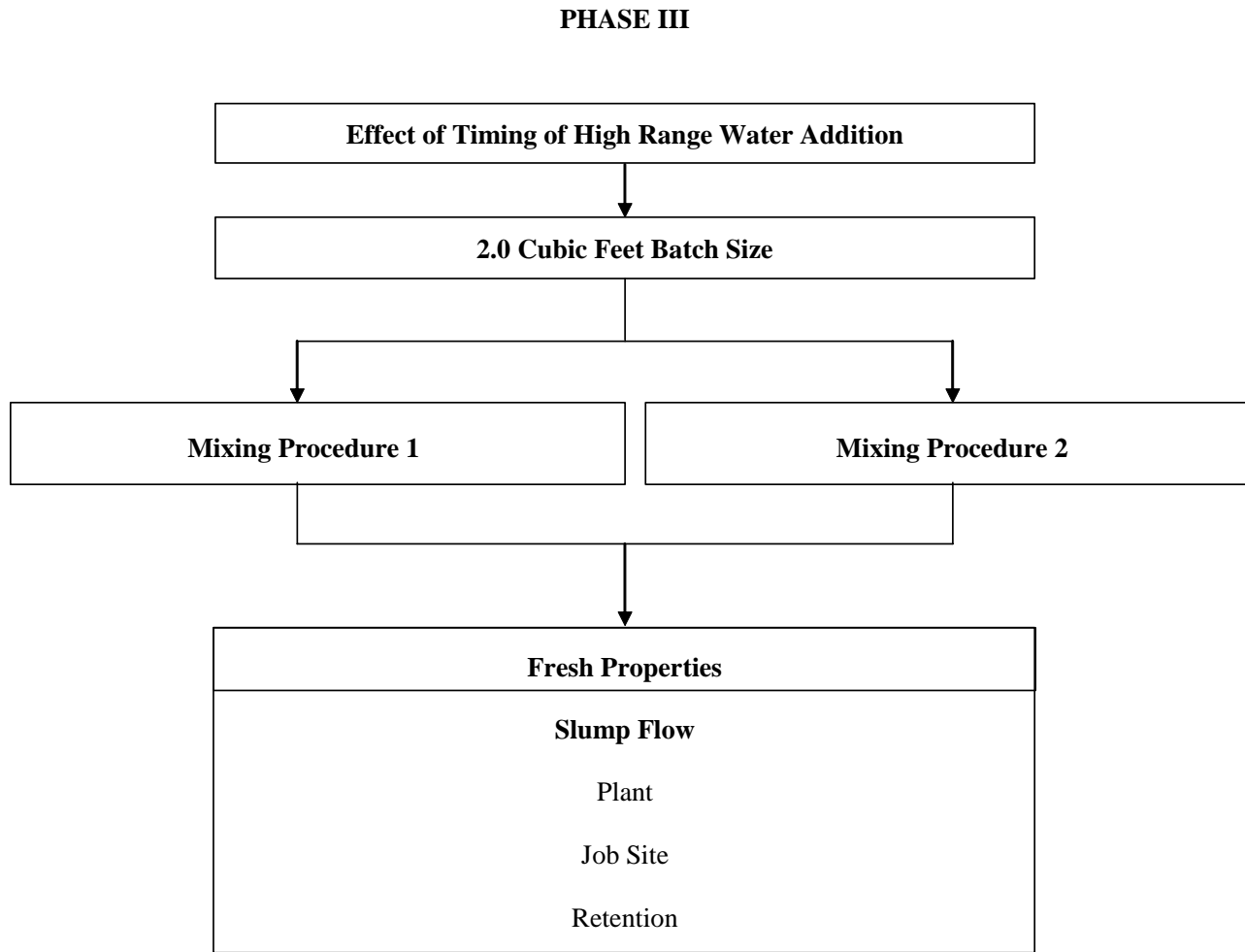


Figure 4.3 – Flow chart for Phase III

4.3.4 Phase IV – Selection of SCC Properties

Phase IV can be considered the most important component and primary focus of this research project. It was determined that the most influential parameters that would affect the fresh and hardened properties of self-consolidating concrete compared to ordinary drilled shaft concrete were the sand-to-aggregate ratio, water-to-cementitious materials ratio, and the use of various type of supplementary cementitious materials. As a result, these were the factors selected to be varied for the SCC mixtures within this phase of the research. This phase of the research project will not only examine different aspects of self-consolidating concrete (SCC) using various mixtures, but will also compare the fresh and hardened concrete properties of SCC and ordinary drilled shaft concrete (ODSC). Figure 4.6 shows the flow chart used for this phase of the project.

There were a total of nine different concrete batches prepared for Phase IV. All of these mixtures were made from materials obtained from South Carolina that will most likely be used during the field project. Two of the concrete mixtures were of ODSC, while the other seven were various SCC mixtures. Table 4.4 presents the mixture proportions and dosages of chemical mixtures used for each concrete mixture. One important point that needs to be considered is that the two ordinary drilled shaft concrete mixtures were not designed by the researcher or the research advisors, rather these concrete mixtures were provided by a ready mix concrete supplier in South Carolina. It was expressed that these concrete mixtures met all requirements for wet-hole construction in South Carolina and are routinely accepted by the South Carolina Department of Transportation (SCDOT) for drilled shaft construction. The use of the two ordinary drilled shaft mixtures will not only provide a means of evaluating the

differences between ordinary drilled shaft concrete and self-consolidating concrete for both fresh and hardened properties, but also assist in the decision of which SCC mixture will be suitable for further evaluation during the construction of full-scale shafts in South Carolina.

A specific identification system for this phase was developed to clearly distinguish each mixture and assist in logging of the test results. The identification system for the ordinary drilled shaft concrete consisted of the mix number followed by ODSC as shown below.

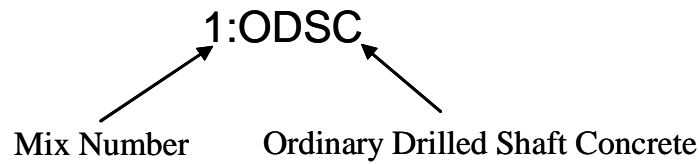


Figure 4.4 – Example of Identification System for Ordinary Drilled Shaft Concrete

The identification system for the SCC mixtures is slightly more complex due to the fact that there are more mixtures with greater discrepancies. The identification system for the SCC mixtures was named in order of the mix number, water-to-cementitious materials ratio, sand-to-aggregate ratio, and supplementary cementitious material type. For example, a SCC mixture with the identity 3:41-48-FA would be the third mixture with a water-to-cementitious materials ratio of 0.41, sand-to-aggregate ratio of 0.48, and comprised of fly ash (FA) as the supplementary cementing material.

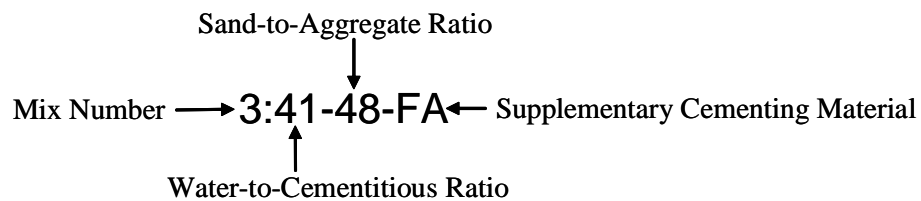


Figure 4.5 – Example of Identification System for SCC Mixtures

Table 4.4 - Concrete Mixture Proportions for Phase IV

Item	Ordinary DSC		Self-Consolidating Concrete Mixtures						
	1:ODCS	2:ODCS	3:41-48-FA	4:41-44-FA	5:41-40-FA	6:36-40-FA	7:36-40-SG	8:36-40-SF	9:36-44-FA
Coarse Aggregate (No. 67) (lb/yd ³)	1458	1778	1082	1191	1304	1300	1326	1286	1208
Coarse Aggregate (No. 789) (lb/yd ³)	320	0	394	434	460	463	478	470	442
Fine Aggregate (lb/yd ³)	1181	1181	1366	1285	1190	1175	1195	1164	1289
Water (lb/yd ³)	289	289	306	293	284	270	270	270	270
Type I Cement (lb/yd ³)	560	560	500	477	465	500	450	442	500
Class F Fly Ash (lb/yd ³)	140	140	250	238	230	250	0	248	250
GGBF Slag (lb/yd ³)	0	0	0	0	0	0	300	0	0
Silica Fume (lb/yd ³)	0	0	0	0	0	0	0	60	0
Target Air (%)	2	2	2	2	2	2	2	2	2
Mid-Range Water Reducer (NP) (oz/cwt)	8	8	0	0	0	0	0	0	0
Mid-Range Water Reducer (PCE) (oz/cwt)	0	0	0	0	0	4	4	4	4
High-Range Water Reducer (PCE) (oz/cwt)	0	0	10	10	10	10	12	12.5	10
Retarder (oz/cwt)	4	4	8	8	8	8	12	12	10
Viscosity Modifying Admixture (oz/cwt)	0	0	2	2	2	2	0	0	2
Water-to-Cementitious Materials Ratio	0.41	0.41	0.41	0.41	0.41	0.36	0.36	0.36	0.36
Sand-to-Aggregate Ratio	0.40	0.40	0.48	0.44	0.40	0.40	0.40	0.40	0.44
Aggregate Volume Fraction (% By Volume)	67	67	64	65	66	66	67	66	66
Paste Volume Fraction (% By Volume)	14	14	16	15	15	16	15	16	16

A batch size of 6.5 ft³ was utilized for the ordinary drilled shaft concrete mixtures and 8.0 ft³ for SCC mixtures. These batch sizes were established based on the required volume of concrete to perform all fresh and hardened concrete tests with the addition of 20% extra volume for waste. The following is a list of the fresh and hardened concrete properties to be tested as well as some specific requirements for this phase of the research.

A. Fresh Concrete Properties

1. Slump Test ASTM C 143 (1998)
 - a. Performed on all ordinary drilled shaft concrete mixtures directly after mixing and at the time of placement
 - b. Performed on all SCC mixtures directly before the addition of the high-range water reducing admixture
 - c. Performed periodically on all ordinary drill shaft concrete mixtures for a duration of no less than 5 hours after batching (slump retention)
2. Slump Flow Test
 - a. Performed on SCC mixtures directly after mixing and at time of placement
 - b. Performed periodically on all self-consolidating concrete mixtures for a duration of no less than 5 hours after batching (slump flow retention)
3. Total Air Content and Unit Weight ASTM C 138 (1998)
 - a. Performed on all concrete mixtures
4. L-Box Test
 - a. Performed on all SCC mixtures at time of placement
5. J-Ring Test
 - a. Performed on all SCC mixtures at time of placement
6. Segregation Column
 - a. Performed on all SCC mixtures at time of placement

7. Bleeding Test ASTM C 232 (1998)
 - a. Performed on all concrete mixtures
 - b. Performed until bleeding of the concrete mixtures has seized
8. Setting by Penetration Resistance ASTM C 403 (1998)
 - a. Performed on all concrete mixtures
 - b. 6 x 6 inch cylindrical specimens of mortar obtained by wet sieving

B. Hardened Concrete Properties

1. Compressive Strength ASTM C 39 (1998) and Elastic Modulus ASTM C 469 (1998)
 - a. 6 x 12 inch cylindrical specimens
 - b. Test 3 cylinders at ages of 3, 7, 14, 28, and 56 days
2. Drying Shrinkage ASTM C 157 (1998)
 - a. 3 concrete prisms 3 x 3 x 12 inch
 - b. Test at ages 1, 2, 3, 7, 14, 28, 56, 91, 180, and 365 days after curing
3. Permeability ASTM C 1202 (1998)
 - a. 4 x 8 inch cylindrical specimens
 - b. Test 3 specimens at ages of 91 and 365 days

C. Requirements

1. The slump of the ordinary drilled shaft concrete mixtures, at the time of placement, shall be 8 ± 1 inches.
2. The slump flow of the SCC mixtures, at the time of placement, shall be 21 ± 3 inches.
3. A 28-day required compressive strength (f_{cr}') of 5,200 psi is needed.
4. No segregation of the concrete mixtures may occur at time of placement. The visual stability index (VSI) of the SCC mixtures, at the time of placement, shall be 1.0 or less.

PHASE IV

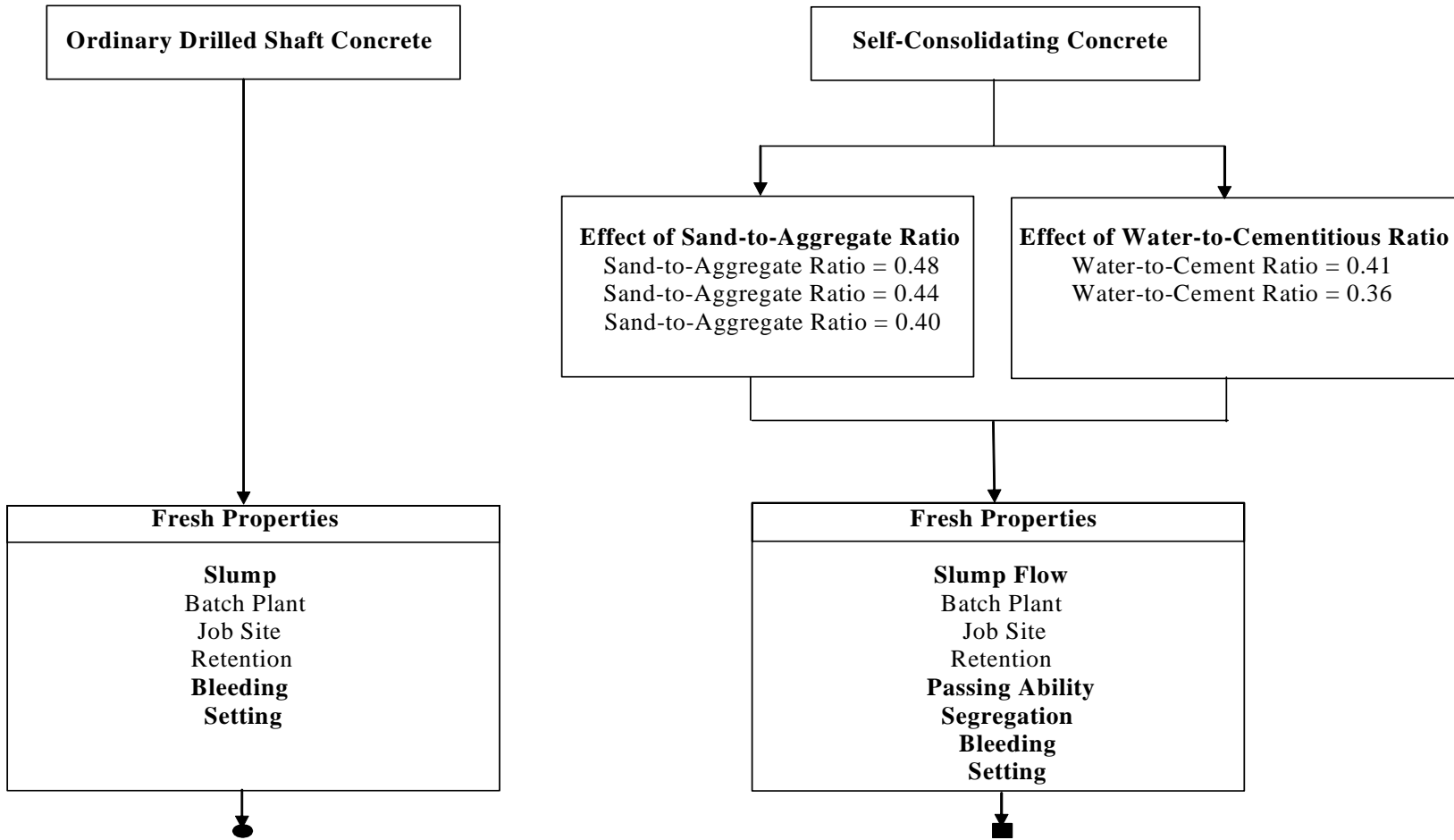


Figure 4.6 – Flow Chart for Phase IV (continued on next page)

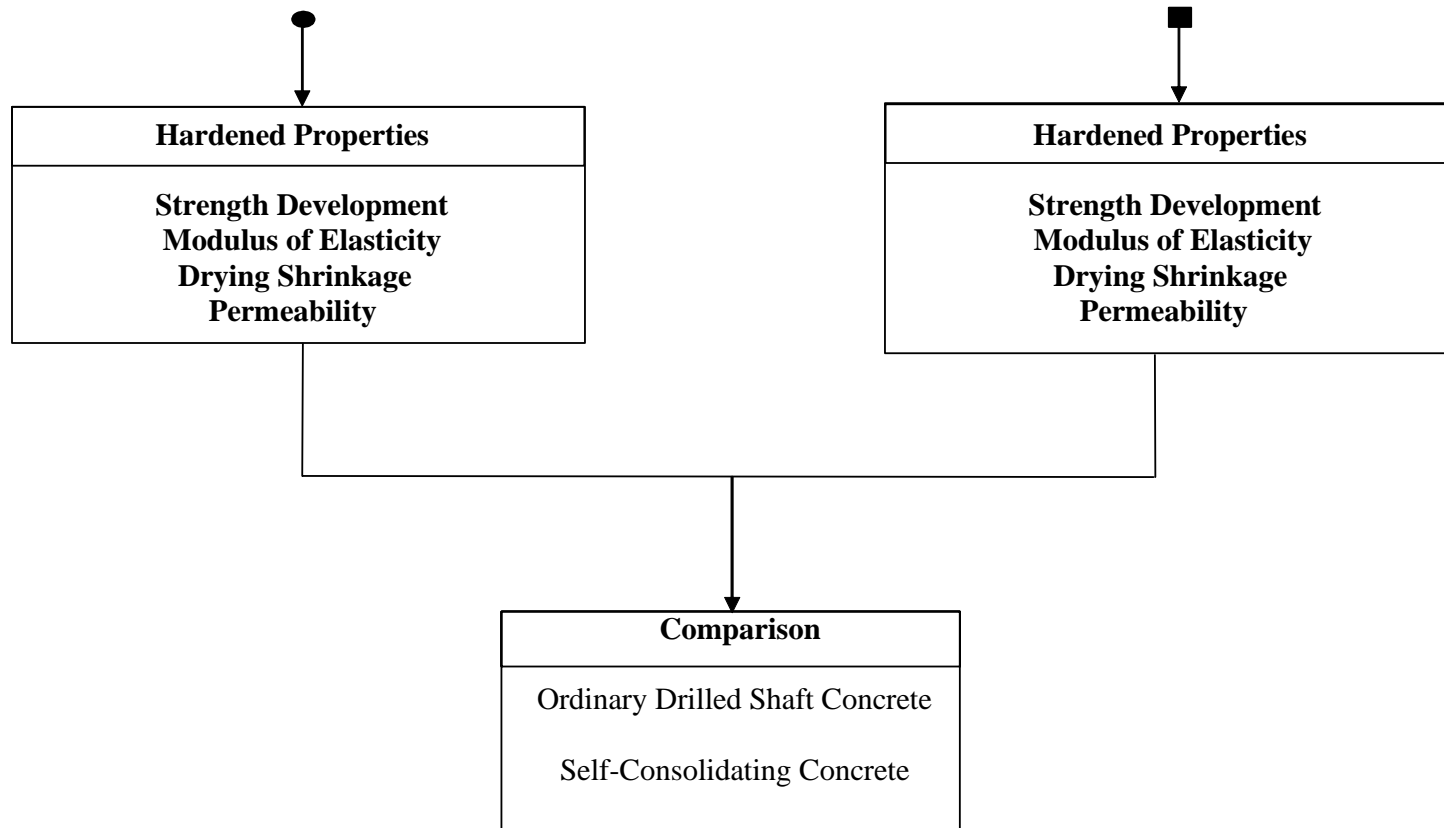


Figure 4.6 – Flow Chart for Phase IV

4.3.5 Phase V – Methods to Modify the Viscosity of SCC Mixtures

Phase V will examine the various methods to modify the viscosity of a SCC mixture. There were a total of 21 different concrete batches prepared for Phase V. Each batch was designed to evaluate a distinct method of modifying the viscosity as identified during the literature review of this research project. These methods included one or more of the following: reduction in water-to-cementitious materials ratio, change in type of supplementary cementing material, and/or VMA dosage. The sand-to-aggregate was held constant at 0.40 for all concrete batches; therefore, only the effect of the different viscosity modifiers will be examined. It was determined that a sand-to-aggregate ratio of 0.40 would be the worst case scenario for not only increasing the viscosity of a concrete mixture, but also increasing the stability of the mixture at higher slump flows. Table 4.5 presents the appropriate mixture proportions and approximate dosages of chemical mixtures used for each concrete mixture.

The identification system for the SCC mixtures was named in order of the mix number, material source, water-to-cementitious materials ratio, and viscosity modifying method. For example, a SCC mixture with the identity 6:AL-36-33 FA would be the sixth mixture with the materials being from a local source in Alabama, water-to-cementitious materials ratio of 0.36, and comprised of 33% fly ash as the viscosity modifying method.

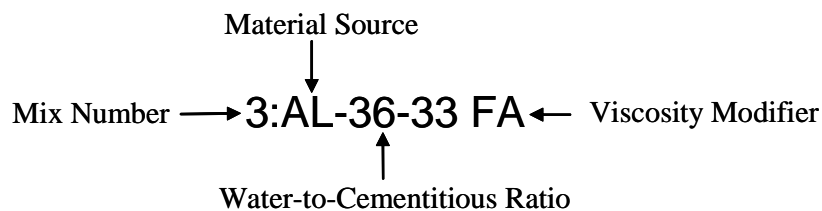


Figure 4.7 – Example of Identification System for Phase V

A batch size of 3 ft³ was established based on the required volume of concrete to perform all fresh and hardened concrete tests with the addition of 20% extra volume for waste for all SCC mixtures. The following is a list of the fresh and hardened concrete properties to be tested as well as some specific requirements for this phase of the research. Figure 4.8 illustrates the flow chart used for this phase of the project.

A. Fresh Concrete Properties

1. Slump Flow Test
 - a. Performed on SCC mixtures directly after mixing and at time of placement
2. Total Air Content and Unit Weight ASTM C 138 (1998)

B. Hardened Concrete Properties

1. Compressive Strength ASTM C 39 (1998) and Elastic Modulus ASTM C 469 (1998)
 - a. 6 x 12 inch cylindrical specimens
 - b. Test 3 cylinders at ages of 7, 28, and 56 days

C. Requirements

1. The slump flow of the SCC mixtures, at the time of placement, shall be 21 ± 3 inches.
2. A 28-day required compressive strength (f_{cr}') of 5,200 psi is needed.
3. No segregation of the concrete mixtures may occur at time of placement. The visual stability index (VSI) of the SCC mixtures, at the time of placement, shall be 1.0 or less.

Table 4.5 - Concrete Mixture Proportions for Phase V

Self-Consolidating Concrete Mixtures	ITEM																		
	Coarse Aggregate (No. 67) (lb/yd ³)	Coarse Aggregate (No. 89) (lb/yd ³)	Fine Aggregate (lb/yd ³)	Water (lb/yd ³)	Type I Cement (lb/yd ³)	Class F Fly Ash (lb/yd ³)	GGBF Slag (lb/yd ³)	Silica Fume (lb/yd ³)	Micron 3 (lb/yd ³)	Lime stone (lb/yd ³)	Target Air (%)	Mid-Range Water Reducer (PCE) (oz/cwt)	High-Range Water Reducer (PCE) (oz/cwt)	Retarder (oz/cwt)	Viscosity Modifying Admixture (oz/cwt)	Water-to-Cementitious Materials Ratio	Sand-to-Aggregate Ratio	Aggregate Volume Fraction (% By Volume)	Paste Volume Fraction (% By Volume)
1:AL-41-0 VMA	1300	463	1188	284	465	230	0	0	0	0	2	0	10	8	0	0.41	0.40	66	15
2:AL-41-2 VMA	1300	463	1188	284	465	230	0	0	0	0	2	0	10	8	2	0.41	0.40	66	15
3:AL-41-10 VMA	1300	463	1188	284	465	230	0	0	0	0	2	0	10	8	10	0.41	0.40	66	15
4:AL-41-18 VMA	1300	463	1188	284	465	230	0	0	0	0	2	0	10	8	18	0.41	0.40	66	15
5:AL-36-33*2FA	1283	461	1192	270	500	250	0	0	0	0	2	4	10	8	2	0.36	0.40	66	16
6:AL-36-33 FA	1264	450	1148	284	529	260	0	0	0	0	2	0	10	8	0	0.36	0.40	64	17
7:AL-36-40 FA	1246	450	1150	284	473	315	0	0	0	0	2	0	10	8	0	0.36	0.40	64	17
8:AL-36-50 FA	1220	450	1150	284	394	395	0	0	0	0	2	0	10	8	0	0.36	0.40	63	18
9:AL-36-6 SF	1225	470	1158	284	497	245	0	47	0	0	2	0	12	8	0	0.36	0.40	64	17
10:AL-36-8 SF	1235	460	1155	284	486	239	0	63	0	0	2	0	13	8	0	0.36	0.40	64	17
11:AL-36-10 SF	1232	460	1155	284	475	234	0	79	0	0	2	0	13	8	0	0.36	0.40	64	17
12:AL-36-15 SF	1228	450	1160	284	449	221	0	118	0	0	2	0	15	8	0	0.36	0.40	64	17
13:AL-36-40 SG	1330	478	1188	270	450	0	300	0	0	0	2	0	12	8	0	0.36	0.40	67	15
14:AL-36-50 SG	1303	468	1150	284	394	0	395	0	0	0	2	0	12	8	0	0.36	0.40	66	15
14:AL-36-50 SG (LA)	1303	468	1150	284	394	0	395	0	0	0	2	20	0	8	0	0.36	0.40	66	15
15:AL-36-60 SG	1292	470	1154	284	316	0	473	0	0	0	2	0	12	8	0	0.36	0.40	66	16
16:AL-36-8 M3	1252	452	1148	284	465	260	0	0	63	0	2	0	10	8	0	0.36	0.40	64	17
17:AL-36-12 M3	1245	452	1148	284	435	260	0	0	94	0	2	0	10	8	0	0.36	0.40	64	17
18:AL-36-16 M3	1244	448	1148	284	403	260	0	0	126	0	2	0	10	8	0	0.36	0.40	64	17
19:AL-36-8 LS	1285	470	1173	270	442	248	0	0	0	60	2	0	10	8	0	0.36	0.40	66	16
20:AL-36-15 LS	1289	465	1168	270	389	248	0	0	0	112	2	0	10	8	0	0.36	0.40	66	16
21:AL-36-20 LS	1275	461	1180	270	352	248	0	0	0	150	2	0	10	8	0	0.36	0.40	66	16

PHASE V

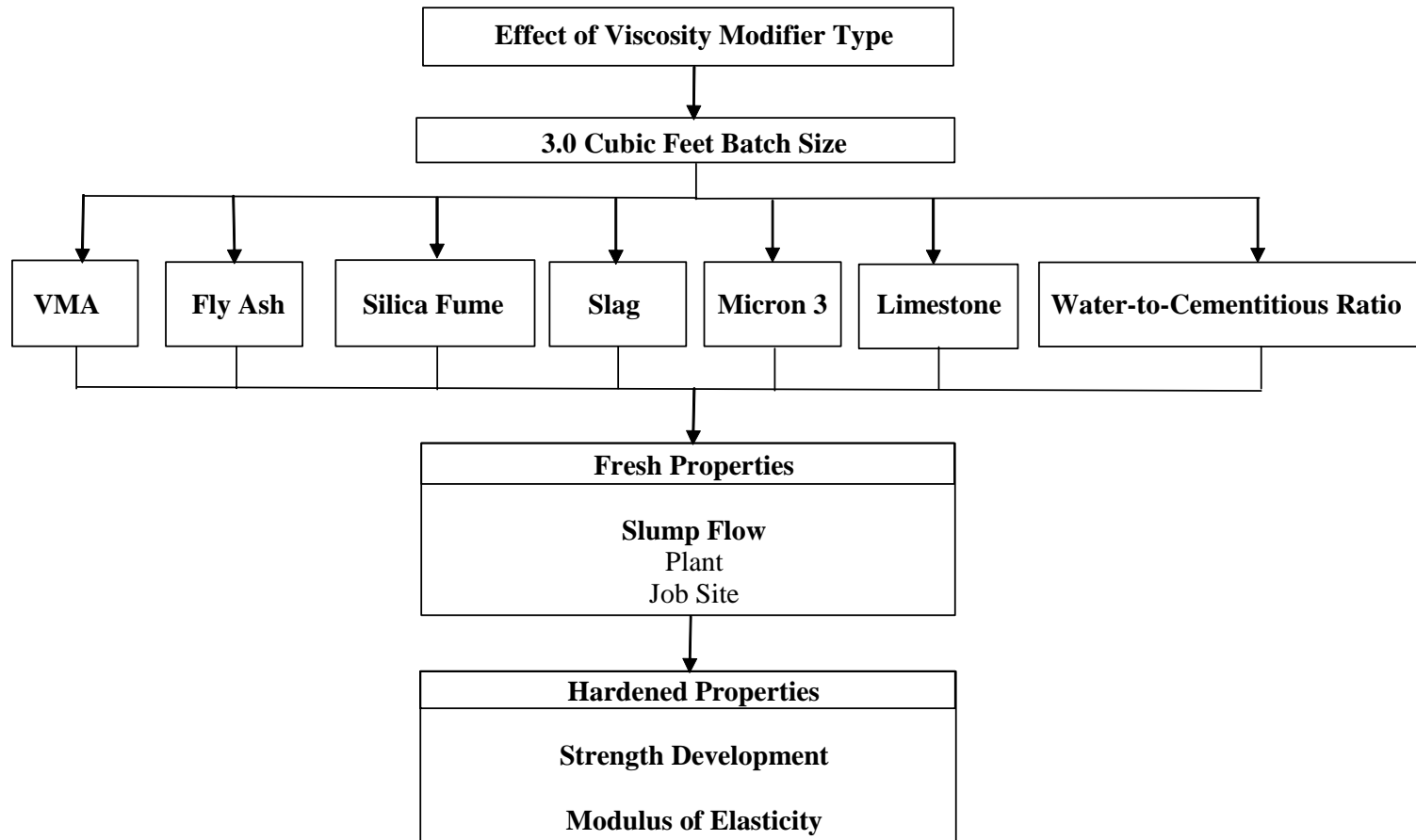


Figure 4.8 – Flow Chart for Phase V

4.4 RAW MATERIAL SOURCES

Section 4.4 will present the raw materials that were used for this research program. The material part is separated into three separate subsections. These subsections include cementitious materials, aggregates, and chemical admixtures. Two sources of aggregates, two different cement sources, and two different sources of fly ash were used in this research. One source of cement, fly ash, and aggregates was imported from South Carolina, which was used for Phases I through IV. Phase V incorporated another source of cement, fly ash, and aggregates that was obtained from a local source located in Alabama. It is important to mention that the raw materials from Alabama were carefully selected to match, as closely as possible, that of the imported raw materials from South Carolina. Due to the limited amount of South Carolina material, it was not feasible to consume the South Carolina material for Phase V since it was not the primary focus of this research. However, closely matching the material sources allowed any valuable information obtained from Phase V to be easily transferable to the South Carolina materials. As a result of this exercise, some mix designs were obtained from Phase V and incorporated in Phase IV using South Carolina materials.

4.4.1 Cementitious Materials

- Type I Portland Cement: There were two different sources of cement used for this research project. The first source of Type I cement was manufactured by Giant Cement Company located in Harleyville, South Carolina. The Giant Type I cement was utilized for Phases I through IV of this research project. The chemical analysis was performed by Analytical Laboratories, Inc. Table 4.6 presents the chemical analysis results performed on this brand of cement.

Furthermore, the Giant Type I cement had a Blaine Fineness of 367 m²/kg as determined by ASTM C 204 (1998). The second source of Type I cement was manufactured by Lafarge Cement, Inc. The Lafarge cement was exclusively utilized for Phase V. In addition, the Lafarge Type I cement had a Blaine Fineness of 398 m²/kg as determined by ASTM C 204 (1998).

Table 4.6 – Chemical Analysis Results for the Giant Type I Cement

Item	% by Weight
Silicon Dioxide, SiO ₂	20.46
Aluminum Oxide, Al ₂ O ₃	4.78
Iron Oxide, Fe ₂ O ₃	3.54
Calcium Oxide, CaO	65.28
Magnesium Oxide, MgO	1.31
Sodium Oxide, Na ₂ O	0.08
Potassium Oxide, K ₂ O	0.1
Total Alkalies as Na ₂ O	0.14
Titanium Dioxide, TiO ₂	0.37
Manganic Oxide, Mn ₂ O ₃	0.04
Phosphorus Pentoxide, P ₂ O ₅	0.1
Strontium Oxide, SrO	0.08
Barium Oxide, BaO	0.03
Sulfur Trioxide, SO ₃	2.57
Tricalcium Silicate, C ₃ S	65.76
Tricalcium Aluminate, C ₃ A	6.69
Dicalcium Silicate, C ₂ S	9.03
Tetracalcium Aluminoferrite, C ₄ AF	10.77

- Class F Fly Ash: As with the cement, there were two main sources of Class F fly ash. One source of Class F fly ash was provided by the SEFA Group in Wateree, South Carolina. The SEFA Group fly ash was utilized for Phases I through IV.

Table 4.7 shows the results of the chemical analysis on this brand of fly ash as performed by Analytical Laboratories, Inc. The second source of fly ash was manufactured by Boral Material Technologies. This brand of fly ash cement was exclusively used for Phase V.

Table 4.7 – Chemical Analysis Results for the SEFA Group Class F Fly Ash

Item	% by Weight
Silicon Dioxide, SiO ₂	52.19
Aluminum Oxide, Al ₂ O ₃	27.83
Iron Oxide, Fe ₂ O ₃	9.06
Calcium Oxide, CaO	1.7
Magnesium Oxide, MgO	0.94
Sodium Oxide, Na ₂ O	0.6
Potassium Oxide, K ₂ O	2.58
Titanium Dioxide, TiO ₂	1.52
Manganese Oxide, MnO ₂	0.05
Phosphorus Pentoxide, P ₂ O ₅	0.37
Strontium Oxide, SrO	0.14
Barium Oxide, BaO	0.19
Sulfur Trioxide, SO ₃	0.24

- Ground Granulated Blast Furnace Slag (GGBFS): The GGBFS used throughout this entire research project was provided by Buzzi Unicem USA, Inc. This slag meets specifications set forth by ASTM C 989 (1998) for a Grade 120 Ground Granulated Blast Furnace Slag.
- Condensed Silica Fume: The silica fume used in this research project was manufactured by Simicala, Inc. located in Mt. Meigs, Alabama.

- Limestone Filler: The limestone filler used in this research project was provided by Sanco, Inc. at their plant in Dalton, Georgia. It is important to note that limestone filler is an inert filler rather than cementitious material. However, it is best to introduce the limestone filler at this point since it is part of the binder content.
- Micron 3: The Micron 3, or commonly know as ultra fine fly ash, used in this research project was provided by Boral Material Technologies, Courtesy of Mr. Russel Hill. Table 4.8 presents the chemical analysis results for the Micron 3.

Table 4.8 – Chemical Analysis Results for the Micron 3 Fly Ash

Item	% by Weight
Silicon Dioxide, (SiO ₂)	49.21
Aluminum Oxide, (Al ₂ O ₃),	26.71
Iron Oxide, (Fe ₂ O ₃)	4.62
Sum of SiO ₂ , Al ₂ O ₃ , Fe ₂ O ₃	80.54
Calcium Oxide, (CaO),	11.72
Magnesium Oxide, (MgO)	2.07
Sulfur Trioxide, (SO ₃)	1.36
Sodium Oxide, (Na ₂ O)	0.48
Potassium Oxide, (K ₂ O)	1.12
Total Alkalies, (as Na ₂ O)	1.22
Available Alkalies, (as Na ₂ O)	0.30

The particle size distribution for all cementitious materials including the limestone filler was determined by a laser particle size analyzer at the Alabama Department of Transportation as shown in Figure 4.9. The particle size distribution

results are illustrated on Figure 4.10. It is important to note that all materials were tested and analyzed in a dry condition. Since the silica fume was tested in a dry condition, the laser particle size analyzer tested the silica fume in its condensed state rather than its individual particles. As a result, the data on Figure 4.10 indicates that the silica fume produced one of the largest particle size distributions. However, if the silica fume was tested in a non-condensed state the particle size distribution would be significantly smaller. Table 4.9 presents the specific gravities for the cementitious materials and limestone filler used throughout this research project.

Table 4.9 – Specific Gravities for Cementitious Materials

Raw Material	Specific Gravity
Giant Type I Cement	3.15
Lafarge Type I Cement	3.15
SEFA Class F Fly Ash	2.28
Boral Class F Fly Ash	2.28
Boral Micron 3 Class F Fly Ash	2.58
GGBFS	2.93
Silica Fume	2.30
Limestone Filler	2.71



Figure 4.9 – Particle Size Analyzer

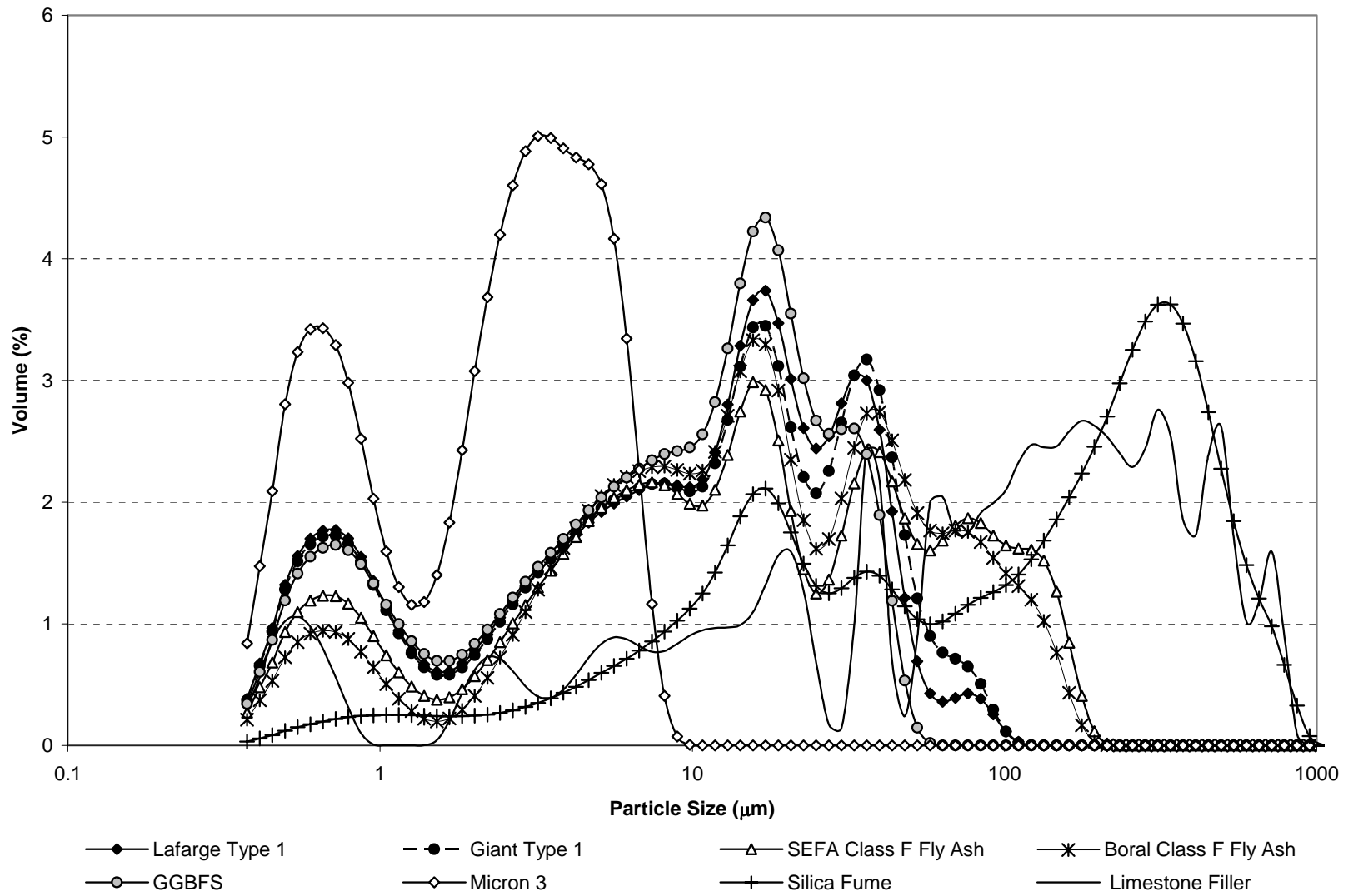


Figure 4.10 – Laser Particle Size Analyzer Results

4.4.2 Aggregates

As previously stated, there were two different aggregate sources used for this research project. One source of aggregate was supplied by the Marlboro Quarry located in South Carolina. The fine and coarse aggregate from South Carolina was placed into “super sacs” and delivered to Auburn University by means of a transfer truck as shown in Figure 4.11. The local source of fine and coarse aggregate was supplied by the Shorter Plant and stocked by Twin City Concrete. Both sources of coarse and fine aggregates were selected to provide necessary aggregate characteristics needed for this research. The nature of river gravel is important because it is composed of particles having a round shape that will provide greater workability as compared to crushed gravel.



Figure 4.11 – Raw Material being Delivered from South Carolina

The coarse aggregate from the Marlboro Quarry consisted of a No. 67 and No. 789 gradation while the fine aggregate classified as FA-10 sand. The coarse aggregate from the Shorter Plant consisted of a No. 67 and No. 89 gradation. It is important to mention that this research originally called for the use of a No. 7 gradation for the SCC mixtures; however, this gradation could not be supplied by a quarry in South Carolina. The No. 7 aggregate was preferred, since it would provide a SCC mixture with higher passing ability. As a result, an aggregate blend comprised of a No.67 and No. 789 was developed. Upon arrival, the aggregates were tested to determine their gradation, absorption capacity, and specific gravities. All aggregates were tested in accordance to ASTM C 33 (2002). Table 4.10 presents the absorption capacities and specific gravities (saturated surface dry). Figures 4.12 through 4.17 show the gradations of the fine and coarse aggregates for both sources.

Table 4.10 – Specific Gravities and Absorption Capacities for Aggregate Sources

Raw Material	Absorption Capacity (%)	Specific Gravity (SSD)
Fine Aggregate (SC)*	0.5	2.63
Fine Aggregate (AL)**	0.68	2.64
No. 67 River Gravel (SC)*	0.4	2.65
No. 67 River Gravel (AL)**	0.57	2.64
No. 789 River Gravel (SC)*	0.4	2.64
No. 89 River Gravel (AL)**	0.62	2.63

* SC = South Carolina Material

** AL = Alabama Material

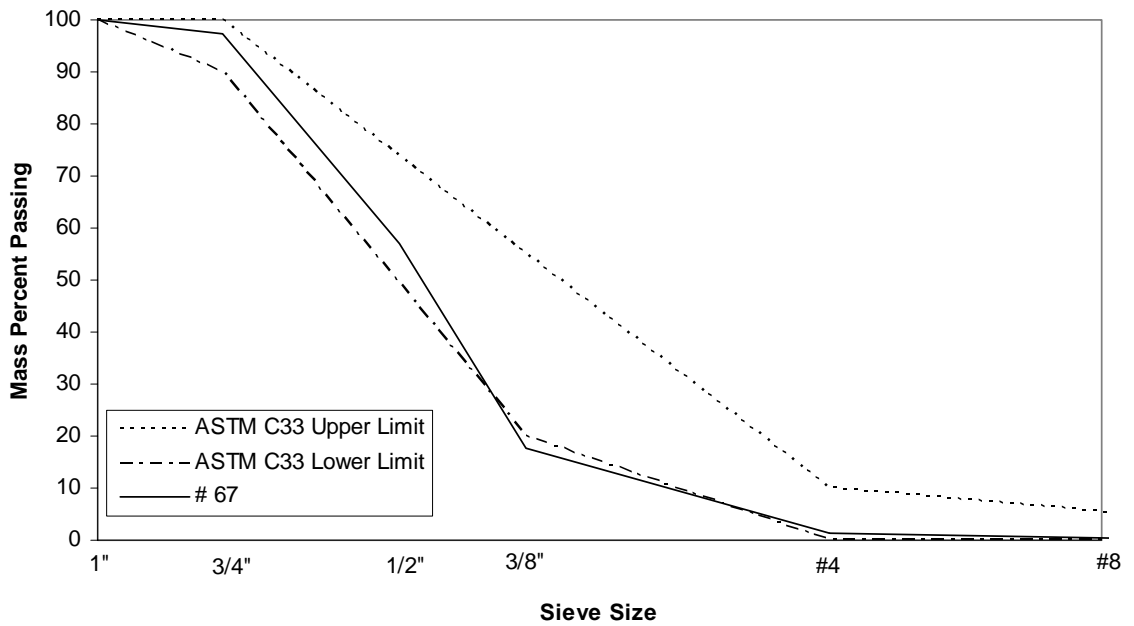


Figure 4.12 – No. 67 Coarse Aggregate Gradation for South Carolina Material

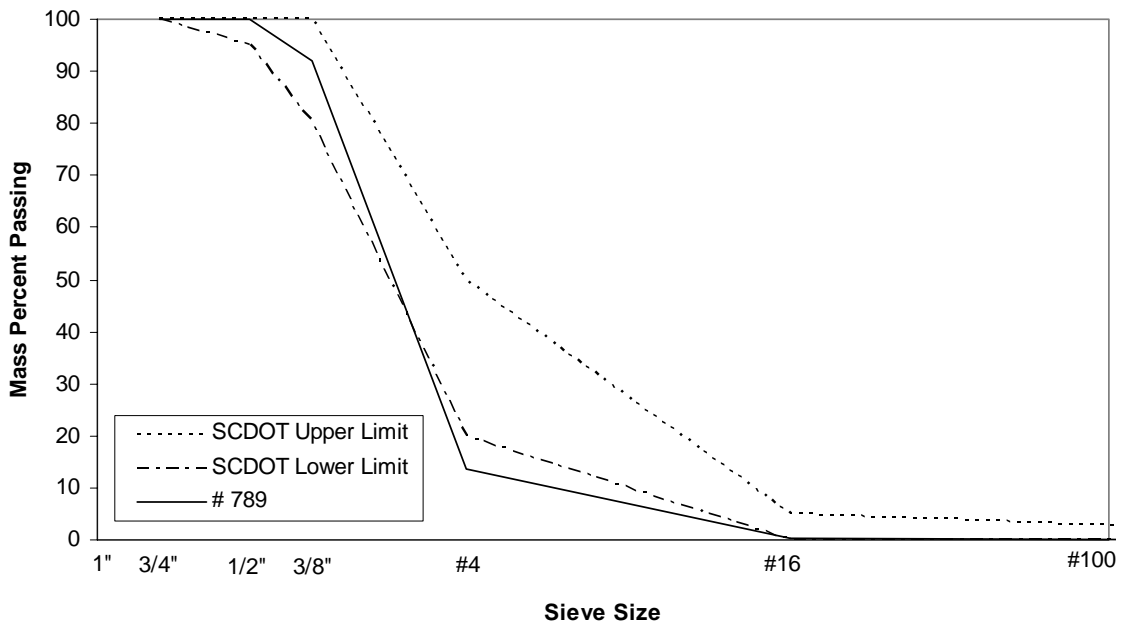


Figure 4.13 – No. 789 Coarse Aggregate Gradation for South Carolina Material

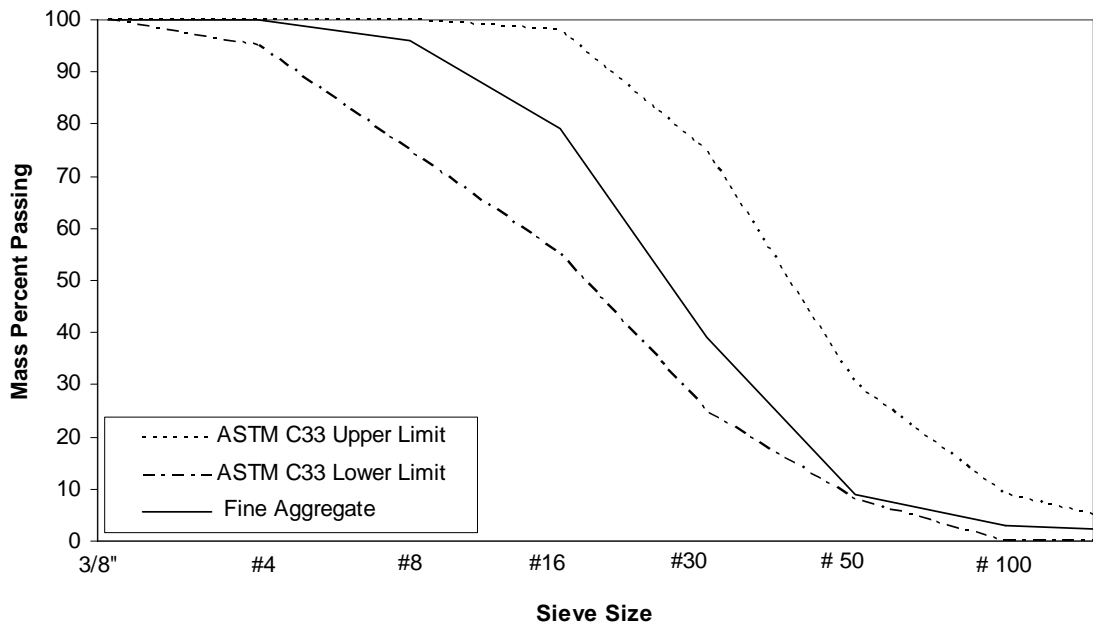


Figure 4.14 – Fine Aggregate Gradation for South Carolina Material

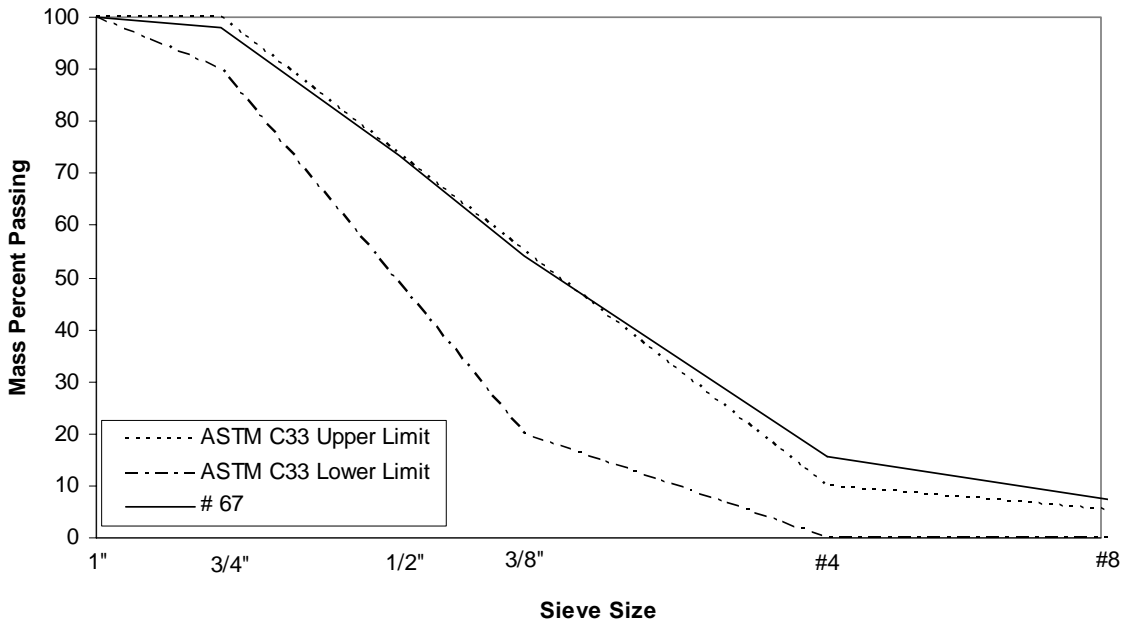


Figure 4.15 – No. 67 Coarse Aggregate Gradation for Alabama Material

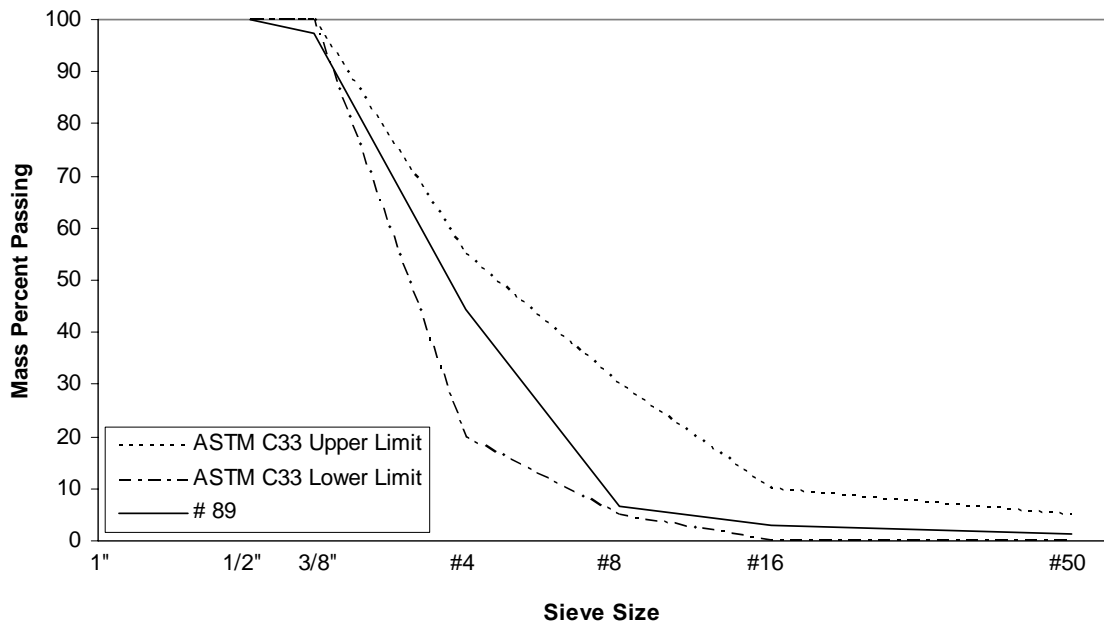


Figure 4.16 – No. 89 Coarse Aggregate Gradation for Alabama Material

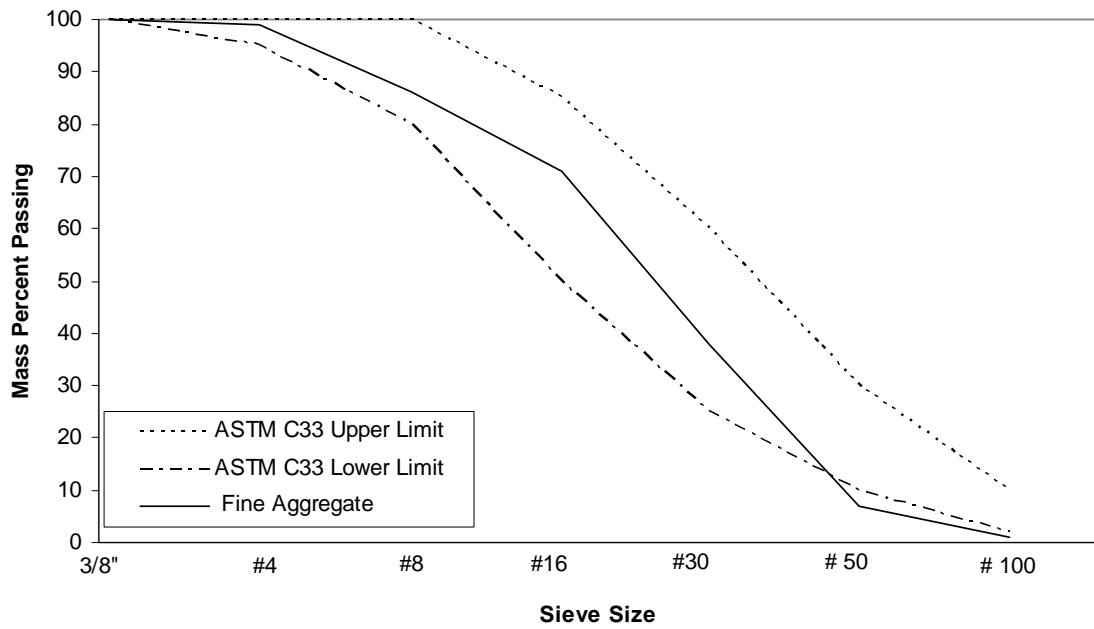


Figure 4.17 – Fine Aggregate Gradation for Alabama Material

4.4.3 Chemical Admixtures

- Supplier: All chemical admixtures were provided by Degussa Admixtures, Inc., which was formally known as Master Builders Technologies.
- Mid-Range Water Reducing Admixture (MRWRA): There were two main types of mid-range water reducing admixtures used for this research project. The first type of MRWR admixture was PolyHeed N, which was only used for the ordinary drilled shaft concrete mixtures. This admixture was not selected by the researcher or the research advisors, instead this admixture type and dosage was provided by a ready mix concrete supplier as described early in Section 4.3.4. PolyHeed N is a chloride bearing mid-range water reducing admixture that meets requirements set forth by ASTM C 494 (1998) for a Type A water reducing admixture. The second type of MRWR admixture used in this research was PolyHeed 1025. This type of MRWR admixture is based on polycarboxylate ester (PCE) technology that meets requirements set forth by ASTM C 494 (1998) for a Type A water reducing as well as a Type F high-range water reducing admixture.
- High-Range Water Reducing Admixture (HRWRA): The HRWR admixtures used for this research project were Glenium 3000 NS and Glenium 3030 NS. Glenium 3000 NS was only utilized for Phase I of the research project. Glenium 3030 NS was used for Phases I through V. This type of HRWR admixture is a chemical admixture based on polycarboxylate ester (PCE) technology. Glenium 3000 NS and 3030 NS meets requirements set forth by ASTM C 494 (1998) for a Type F high-range water reducing admixture.

- Retarding Admixtures: There were two main types of retarding admixtures used for this research project. The first type of retarding admixture was Pozzolith 100 XR, which was only used for the ordinary drilled shaft concrete mixtures. This admixture was not selected by the researcher or the research advisors, instead this admixture type and dosage was provided by a ready mix concrete supplier as described early in Section 4.3.4. Pozzolith 100 XR meets requirements set forth by ASTM C 494 (1998) for a Type B retarding and Type D water reducing and retarding admixture. The second type of retarding admixture utilized in this research was Delvo Stabilizer. Delvo Stabilizer meets requirements set forth by ASTM C 494 (1998) for a Type B retarding and Type D water reducing and retarding admixture.
- Viscosity Modifying Admixture (VMA): The VMA used in this research project was Rheomac 358. Rheomac 358 is a polyethylene glycol based or “thickening type” viscosity modifying admixture.

CHAPTER 5

LABORATORY EQUIPMENT, SPECIMENS, AND PROCEDURES

5.1 INTRODUCTION

Before discussing the laboratory equipment, specimens, and procedures it may be beneficial to describe in short detail the recently acquired equipment relevant to this research obtained by Auburn University. Prior to the summer of 2003, all concrete mixing was completed outside. The outside environment was subject to ambient conditions that produced significant temperature and moisture variations. A new state of the art mixing facility was built inside the Harbert Engineering Center. The new mixing facility consists of an elevated platform with easy access by stairs or ramp, new 12 ft³ concrete mixer, drainage tank, storage area for materials, and moisture corrections area. Furthermore, the facility eliminated the temperature and moisture variations associated with the outside mixing facility, and it now forms one of the most important components of the concrete research conducted at Auburn University. The new mixing facility is shown on Figure 5.1. The addition of a new 600-kip Forney compression machine, rapid chloride permeability cells, compressometer, and length comparator apparatus has allowed more accurate measurements to be taken for the assessment of various fresh and hardened concrete properties that may affect the concrete's performance.



Figure 5.1 – New Indoor Mixing Facility

5.2 BATCHING AND MIXING PROCEDURE

The batching procedure for this research began by obtaining an estimated weight amount of coarse or fine aggregate, which was then carefully placed on a plastic sheet. The fine or coarse aggregate was thoroughly mixed using a shovel to ensure that the aggregate was of homogeneous moisture content. The aggregate was then placed into 5 gallon buckets that were tightly sealed with a lid and moved into the mixing room. Afterwards, moisture corrections were conducted by obtaining small samples (300-500g) of coarse and fine aggregate, which was then placed in a small microwavable dish. The samples were subsequently placed into a microwave and dried to constant weight using a small digital scale. After the moisture content in the coarse and fine aggregate was obtained, the mixing water and aggregate weights were adjusted to account for the

moisture condition of the aggregates. The weight of the coarse aggregate, fine aggregate, cementitious material, and mixing water was then measured into 5 gallon buckets using a balance. The chemical admixtures were measured and obtained using 10 and 50 cc syringes.

Before the mixing procedure began, the concrete mixer was prepared using a “butter batch”. The butter batch typically consisted of placing a small amount of cement, sand, and water inside the concrete mixer that would thoroughly coat the mixer’s wall. The purpose of this exercise was to ensure that no cement or free water would be lost or soaked up by the concrete mixer wall. The 12 ft³ concrete mixer that was used for this project can be seen in Figure 5.2. After the preparation of the mixer was complete, the following mixing procedure was followed. This mixing procedure for the SCC mixtures was based on results from Phase II of the research project.

1. Add 80% of the mixing water into the mixer.
2. Place the coarse and fine aggregate into the mixer.
3. Add any retarding admixtures.
4. Mix for 1 minute.
5. Add cementitious materials.
6. Add the rest of the mixing water.
7. Add any VMA while the concrete is mixing.
8. Mix concrete for 2 minutes.
9. Stop the mixer and take a water slump reading.
10. Add any water reducing admixtures.
11. Run the mixer for 3 minutes.
12. Rest for 3 minutes.
13. Run the mixer for an additional 2 minutes.
14. Stop the mixer and take a slump or slump flow reading. This represents testing at the batch plant.

15. Run the mixer for an additional 50 minutes. This accounts for the transportation time that will be required.
16. Stop the mixer and take a slump or slump flow reading. This represents testing at the job site.
17. Proceed to make all fresh and hardened concrete specimens for testing.



Figure 5.2 – 12 ft³ Concrete Mixer used for this Research

5.3 FRESH PROPERTY TESTING

The fresh concrete properties tested for this research include the slump test, slump flow test, J-Ring test, L-Box test, bleeding test, unit weight, air content, and time of set. It is important to observe that the determination of the filling ability of SCC by the slump flow test, determination of passing ability of SCC by means of the J-Ring and/or L-Box, and determination of segregation resistance by the segregation column test has not yet been standardized by organizations such as ASTM. As a result, it may be useful to describe these tests in more detail so that the reader can become familiar with the

equipment and methodology. It must be noted that the procedures presented in the following sections are only an interim guideline until a fully detailed procedure is standardized.

5.3.1 Slump Test

Slump tests were performed on the concrete mixtures via the procedure in ASTM C 143 (1998), *Standard Test Method for Slump of Hydraulic-Cement Concrete*. The purpose of this test is to determine consistency of the concrete mixtures. All equipment used met the requirements of this specification. The mold, base plate, tape measure, 5/8 inch tamping rod, funnel, and scoop can be seen in Figure 5.3. The slump test was performed on the SCC mixtures before the addition of superplasticizers. Therefore, there was no modification to this test to account for SCC characteristics. The slump tests were conducted by one technician so that any variability in results could be reduced.



Figure 5.3 – Testing Equipment for Slump Test

5.3.2 Slump Flow Test

The slump flow test was performed on all SCC mixtures via the procedure recommend by the PCI (2003). The purpose of this test was to determine the filling ability of a SCC mixture in the absence of obstructions, and to provide a measure of segregation resistance by assigning a stability rating. The equipment and procedure required to perform the slump flow test are listed below. Figure 5.4 demonstrates the equipment used to perform the slump flow test.

Equipment:

1. Mold similar to the one required by ASTM C 143 (1998), *Standard Test Method for Slump of Hydraulic-Cement Concrete*
2. Base plate consisting of a non-absorbing stiff material measuring at least 36 inches square marked with a concentric circle marking the central location of the mold and at least one further circle 20 inches in diameter indicating the T₅₀ location
3. 5/8 inch tamping rod
4. Scoop
5. Tape measure
6. Funnel
7. Stop watch



Figure 5.4 – Testing Equipment for Slump Flow Test

Procedure (PCI 2003):

1. Moisten all equipment and place on a flat and rigid surface.
2. After the mixture procedure is complete, sample approximately 0.2 ft³ of SCC in accordance with ASTM C 172 (1998).
3. Position the mold, with the base downwards, in the center of the base plate.
4. Place the SCC sample into the mold by means of a bucket and funnel. The mold needs to be kept in position.
5. Strike off any excess SCC by means of rolling the tamping rod over the surface.
6. Remove any excess SCC around the base of the mold by means of an absorbent sponge.
7. Lift the mold vertically a distance of 12 inches in approximately 5 seconds without lateral movement allowing the concrete to flow out freely.
8. Simultaneously start a stop watch when the cone is lifted, and record the time taken for the SCC to reach the 20 inch diameter circle (T₅₀ time).
9. Measure the final diameter of the SCC in two perpendicular directions.

10. Calculate the average of the two diameters and report the result to the nearest ¼ inch.
11. After the flow has ceased, assign a stability rating to the SCC mixture according to Table 5.1 and Figure 5.5.

Table 5.1 – Visual Stability Index (VSI) Rating (Khayat et al. 2004)

Rating	Criteria
0	No evidence of segregation in slump flow patty, mixer drum, or wheelbarrow
1	No mortar halo in slump flow patty, but some slight bleeding on surface of concrete in mixer drum and/or wheelbarrow
2	Slight mortar halo (<10mm) in slump flow patty and noticeable layer of mortar on surface of testing concrete in mixer drum and wheelbarrow
3	Clearly segregating by evidence of large mortar halo (>10mm) and thick layer of mortar and/or bleed water on surface of testing concrete in mixer drum or wheelbarrow

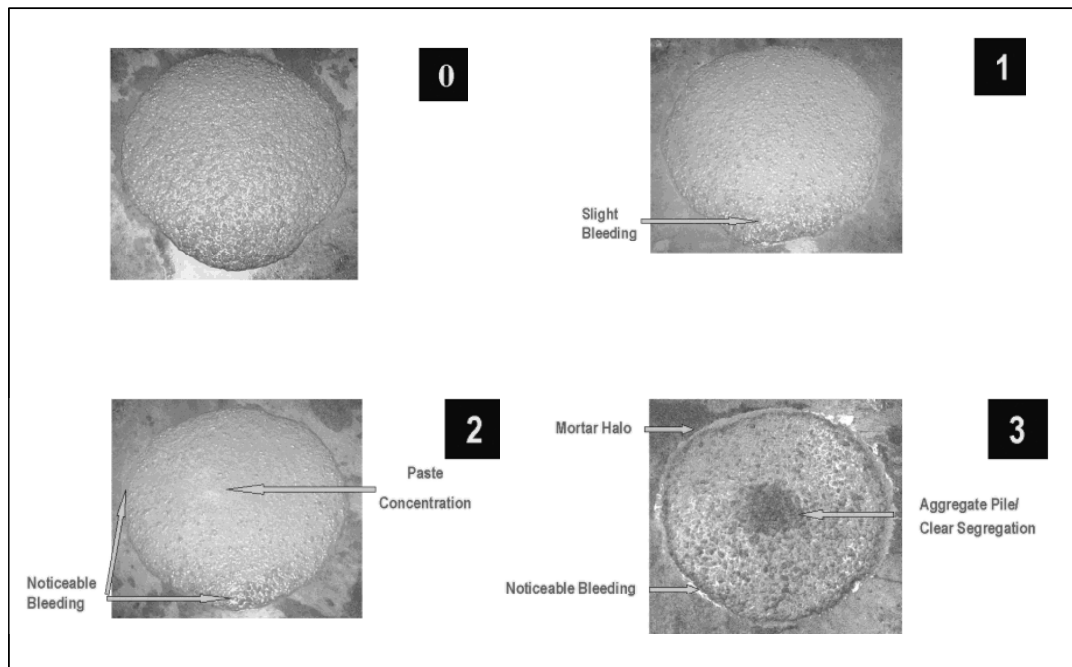


Figure 5.5 - Visual Stability Index Rating (Degussa Construction Chemicals 2004)

The slump flow test was frequently performed in the inverted position in conjunction with the J-Ring test. Under these circumstances, the mold was placed on the base plate with its 4 inch diameter facing downward. Furthermore, the slump flow tests were conducted by two technicians. The second technician timed the test while the other lifted the mold. The use of such practice helped reduce the operator error and improve the accuracy of the T_{50} times.

5.3.3 J-Ring Test

The J-Ring test was performed on the SCC mixtures via the procedure recommended by the PCI (2003). The purpose of this test was to determine the passing ability of a SCC mixture by comparing the slump flow diameter to the J-Ring diameter. Since the slump flow test was used in conjunction with the J-Ring test, the equipment required to perform the J-Ring test is similar to the slump flow test with the addition of the J-Ring as shown in Figure 5.6. The J-Ring apparatus consisted of a rectangular section $1 \frac{1}{8}$ by 1 inch open steel circular ring that measured approximately 12 inches in diameter. The open steel circular ring was drilled vertically to accept $16\text{-}\frac{5}{8}$ inch diameter reinforcement bars measuring 4 inches in height with a center to center spacing of approximately $2 \frac{5}{16}$ inches.



Figure 5.6 – Testing Equipment for J-Ring Test

Procedure (PCI 2003):

1. Moisten all equipment and place on a flat and rigid surface.
2. After the mixture procedure is complete, normally sample approximately 0.2 ft³ of SCC in accordance with ASTM C 172 (1998).
3. Position the mold, with its 4 inch diameter facing downwards, in the center of the base plate.
4. Place the SCC sample into the mold by means of a bucket.
5. Strike off any excess SCC by means of rolling the tamping rod over the surface.
6. Remove any excess SCC around the base of the mold by means of an absorbent sponge.
7. Lift the mold vertically a distance of 9 +/- 3 inches in 3 seconds without lateral movement allowing the concrete to flow out freely.
8. Measure the final diameter of the SCC in two perpendicular directions.
9. Calculate the average of the two diameters and report the result to the nearest 1/4 inch.

10. Conduct the slump test using the inverted method with the provided procedure in Section 5.2.2.
11. Calculate the difference between the J-Ring diameter and the slump flow diameter of the companion test.
12. Assign a passing ability rating according to Table 5.2.

Table 5.2 - J-Ring Passing Ability Rating (ASTM J-Ring Draft 2004)

Difference between Slump Flow and J-Ring Flow	Passing Ability Rating	Remarks
$0 \leq X \leq 1$ inch	0	No visible blocking
$1 < X \leq 2$ inches	1	Minimal to noticeable blocking
$X > 2$ inches	2	Noticeable to extreme blocking

5.3.4 L-Box Test

The L-Box test was performed on the SCC mixtures via the procedure recommended by the PCI (2003). The purpose of this test was to determine the passing ability of a SCC mixture by determining the extent of blocking by reinforcement. The equipment required to perform the L-Box test is listed below and can be seen in Figure 5.7 and 5.8.

Equipment:

1. L-Box made of non-absorbing material with the dimensions shown in Figure 5.7
2. 5/8 inch tamping rod
3. Scoop
4. Tape measure

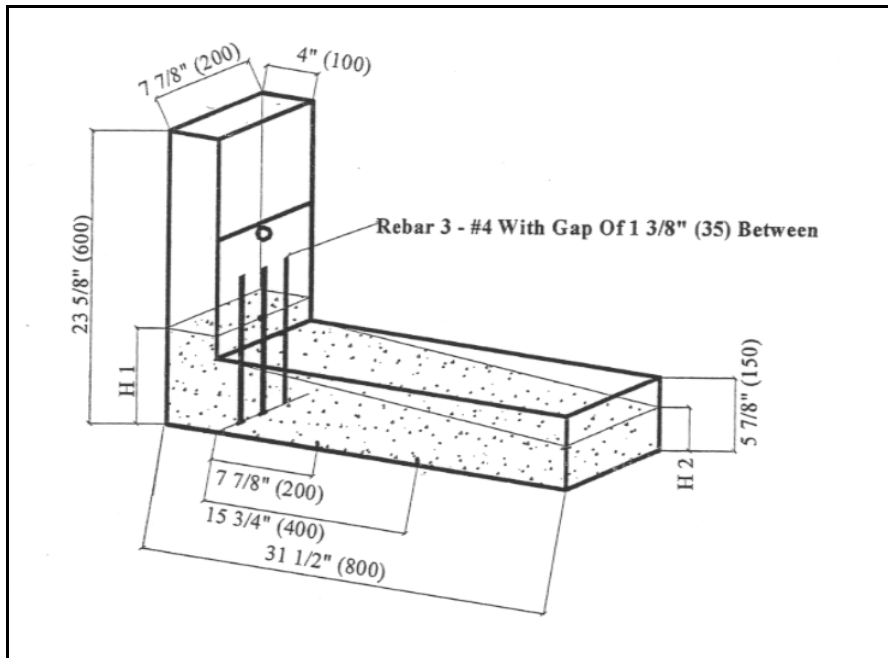


Figure 5.7 – L-Box Dimensions (PCI 2003)



Figure 5.8 – Testing Equipment for L-Box Test

Procedure (PCI 2003):

1. Moisten all equipment and place on flat and rigid surface.
2. After the mixture procedure is complete, sample approximately 0.5 ft³ of SCC in accordance with ASTM C 172 (1998).
3. Ensure that the sliding gate can open freely and then close the gate.
4. Fill the vertical section of the L-Box with the SCC mixture.
5. Let the SCC mixture stand for approximately 1 minute.
6. Strike off any excess SCC by means of rolling the tamping rod over the surface.
7. Lift the gate and allow the SCC mixture to flow into the horizontal section.
8. When the flow has ceased, measure and record the “H1” and “H2” dimensions, shown in Figure 5.7.
9. Calculate the blocking ratio, H2/H1.

5.3.5 Segregation Column Test

The segregation column test was performed on the SCC mixtures via the procedure recommended by an ASTM Segregation Column draft (2004). The purpose of this test was to determine the stability and segregation resistance of a SCC mixture. The equipment required to perform the segregation column test is listed below and can be seen in Figure 5.9.

Equipment:

1. Balance or scale accurate to 0.1 lb. or to within 0.3% of the test load
2. Column mold made of schedule 40 PVC pipe measuring 8 inches in diameter and 26 inches in height and separated into 4 equal sections each measuring 6.5 inches in height

3. Collection plate made of a non-absorbent material measuring 20 inches square containing a semi-circular cut out section in the center measuring 8.5 inches across
4. 5/8 inch tamping rod
5. No. 4 Sieve



Figure 5.9 – Testing Equipment for Segregation Column Test

Procedure (ASTM Segregation Column Draft 2004):

1. Assemble and moisten all equipment, then place on flat and rigid surface.
2. After the mixture procedure is complete, sample approximately 0.8 ft³ of SCC in accordance with ASTM C 172 (1998).

3. Immediately fill the column mold in one continuous lift allowing the concrete to over fill the top.
4. Strike off any excess SCC by means of rolling the tamping rod over the surface.
5. Allow the SCC to set for 1 hour. This time was extended to 1 hour from the 20 minute recommendation provided by the ASTM Segregation Column draft (2004). It was expected that due to the extended set times for drilled shaft concrete that the segregation would be more pronounced after 1 hour.
6. Place the collection plate around the mold and firmly hold the top section of mold while removing the spring clamps.
7. Screed the SCC onto the collection plate by using a horizontal twisting motion of the PVC pipe.
8. Place the obtained SCC from the collection plate into a No. 4 Sieve. Wet wash the sample leaving only the coarse aggregate on the No. 4 sieve.
9. Repeat steps 7 and 8 for the bottom section of the column.
10. Calculate the segregation index using the Equation 5.1 and 5.2.

$$SI = \frac{(CA_B - CA_T)}{CA_{BM}} \quad \text{Eq. 5.1}$$

Where:

SI is the segregation index,

CA_T is the mass of coarse aggregate in the top section (lbs),

CA_B is the mass of coarse aggregate in the bottom section (lbs), and

CA_{BM} is the mass coarse aggregate (lbs) per section of the column according to Equation 5.2.

$$CA_{BM} = 0.007 * CA_M [0.0052 * CA_M] \quad \text{Eq. 5.2}$$

Where:

CA_M is the mass of coarse aggregate (lbs) in 1 yd³ of concrete.

5.3.6 Bleeding Test

Bleeding tests were performed on all SCDOT concrete mixtures via the procedure in ASTM C 232 (1998), *Standard Test Method for Bleeding of Concrete* using Method A. The purpose of this test was to determine the relative quantity of mixing water that will bleed from a freshly mixed concrete sample. All equipment used met the requirements of this specification. The ½ cubic foot container, scale, pipet, mallet, and glass graduate can be seen in Figure 5.10. After placement of the concrete mixture into the ½ cubic foot container, the accumulated bleed water was drawn off the surface until cessation of bleeding. The accumulated bleed water was placed into a 100-mL graduate and recorded after each transfer. The total amount of bleed water was recorded and expressed as a percentage of the net mixing water contained in the test specimen. This procedure was followed as closely as possible for all SCC mixtures with the following modifications. These modifications were necessary to account for SCC characteristics.

1. The SCC mixtures were placed in the container in one continuous lift without any rodding.
2. The tapping of the sides 10 to 15 times with the approximate mallet was not conducted for the SCC mixtures.



Figure 5.10 – Testing Equipment for Bleeding Test

5.3.7 Unit Weight and Air Content

The unit weight and air content was determined for all concrete mixtures via the procedure in ASTM C 138 (1998), *Standard Test Method for Unit Weight, Yield, and Air Content*. The purpose of this test was to determine the weight per cubic foot and air content of freshly mixed concrete. All equipment used met the requirements of this specification. The balance, 5/8 inch tamping rod, measure, strike off plate, and mallet can be seen in Figure 5.11. This procedure was followed as closely as possible for all SCC mixtures with the following modifications. These modifications were necessary to account for SCC characteristics.

1. The SCC mixtures were placed in the measure in one continuous lift without any rodding.
2. The tapping of the sides 10 to 15 times with the approximate mallet was reduced to no more than 5 soft taps by hand or mallet for all SCC mixtures. The purpose of this exercise was to help alleviate any large

entrapped air pockets that remained along the cylinder walls while providing little or no consolidation effort.



Figure 5.11 – Testing Equipment for Unit Weight and Air Content

5.3.8 Making and Curing Specimens

The making and curing of concrete specimens were performed according to ASTM C 192 (1998), *Standard Practice for Making and Curing Concrete Test Specimens in the Laboratory*. After strike off, all specimens were capped with a tightly sealed lid. The cylinders remained in the mixing room for a period of 24 hours or until 2 times the initial set was achieved due to extended setting times of the drilled shaft concrete mixture. Cylinders were then relocated from the mixing room, stripped of their molds, and placed in a moist curing room. The conditions of the moist cure room were held constant at a temperature of 73° F and relative humidity of 100%. The cylinders remained in the curing room until testing. This procedure was followed as closely as

possible for all SCC mixtures with the following modifications. These modifications were necessary to account for SCC characteristics.

1. The SCC mixtures were placed into the cylinder molds in one continuous lift without any rodding.
2. The tapping of the sides 10 to 15 times with the approximate mallet was reduced to no more than 5 soft taps by hand or mallet for all SCC mixtures. The purpose of this exercise was to help alleviate any large entrapped air pockets that remained along the cylinder walls while providing little or no consolidation effort.

5.3.9 Time of Set

Setting tests were performed on all SCDOT concrete mixtures via the procedure in ASTM C 403 (1998), *Standard Test Method for Time of Setting of Concrete Mixtures by Penetration Resistance*. The purpose of this test was to determine the time of setting for freshly mixed concrete mixture by means of penetration resistance. All equipment used met the requirements of this specification. The mortar container, penetration needles, pipet, and loading apparatus can be seen in Figure 5.12. Each mortar sample was obtained by vibrating a portion of the concrete mixture over a No. 4 sieve, and then placing the mortar into the metal container shown in Figure 5.12. The specimens were kept sealed by a tightly placed lid to prevent the occurrence of evaporation. Prior to the removal of the bleed water, a wedge was inserted under the container to facilitate the collection of bleed water. The lid was then removed for bleed water draw off and testing. The testing consisted of making no less than six penetrations until at least one penetration

resistance reading equaled or exceeded 4,000 psi. The specimens were maintained at mixing room temperature for the entire period until final set was achieved. There were no necessary modifications to this test to account for SCC characteristics.



Figure 5.12 - Testing Equipment for Time of Setting

5.4 HARDENED CONCRETE PROPERTIES

5.4.1 Compressive Strength

The compressive strength of the 6 x 12 inch cylindrical concrete specimens was tested in accordance with ASTM C 39 (1998), *Standard Test Method for Compressive Strength of Cylindrical Concrete Specimens*. The equipment used in the laboratory to determine the compressive strength of the specimens met all requirements set forth by this standard. The specimens were tested using unbonded caps that consisted of a steel

retaining ring and neoprene pads. The unbonded caps meet all requirements described by ASTM C 1231 (1998), *Standard Practice for use of Unbonded Caps in Determination of Compressive Strength of Hardened Concrete Specimens*. The load rate utilized for the 6 x 12 inch specimens was 35 psi/sec., which corresponds to a value of 60,000 lbs/min. Each specimen was loaded in a 600 kip Forney compression machine as shown in Figure 5.13 until failure occurred.



Figure 5.13 – 600 Kip Forney Compression Machine

5.4.2 Modulus of Elasticity

The modulus of elasticity of the 6 x 12 inch cylindrical concrete specimens was tested in accordance with ASTM C 469 (1998), *Standard Test Method for Static Modulus of Elasticity and Poisson's Ratio Strength of Concrete in Compression*. The purpose of this test was to determine the chord modulus of 6 x 12 inch specimens. The equipment used in the laboratory to determine the elastic modulus of the concrete specimens met all

requirements set forth by this standard. The specimens were tested using unbonded caps that consisted of a steel retaining ring and neoprene pads. The unbonded caps meet all requirements described by ASTM C 1231 (1998), *Standard Practice for use of Unbonded Caps in Determination of Compressive Strength of Hardened Concrete Specimens*. A Humboldt compressometer equipped with a digital dial gauge was used to determine the elastic modulus of the concrete specimen. The researcher ensured that the compressometer was positioned evenly from the top, bottom, and sides. The concrete specimen was subsequently placed in the 600 kip Forney compression machine and tested as shown in Figure 5.14. The load rate utilized for the 6 x 12 inch concrete specimens was 35 psi/sec., which corresponds to a value of 60,000 lbs/min. Each specimen was first loaded to 40% of the ultimate strength without recording any data. The purpose of this exercise was to ensure that all equipment was properly seated and working correctly. The load was re-applied while recording the appropriate data. After the data was recorded, the modulus of elasticity was determined according to Equation 5.3.

$$E = \frac{(S_2 - S_1)}{(\varepsilon_2 - 0.00005)} \quad \text{Eq. 5.3}$$

Where,

E = Chord modulus of elasticity, psi,

S₂ = Stress corresponding to 40% of the ultimate load, psi,

S₁ = Stress corresponding to a longitudinal strain of 50 millionths, psi,

ε₂ = longitudinal strain produce by S₂



Figure 5.14 – Concrete Specimen with Compressometer Attached

5.4.3 Drying Shrinkage

The length change of 3 x 3 x 12 inch concrete specimens was tested in accordance with ASTM C 157 (1998), *Standard Test Method for Length Change of Hardened Hydraulic-Cement Mortar and Concrete*. The purpose of this test was to determine the length change of the concrete specimens due to drying shrinkage. The equipment used in the laboratory to determine the length change of the concrete specimens met all requirements of this specification. The concrete specimens were allowed to cure for 28 days in a lime saturated bath. Afterwards, the concrete specimens were removed and placed into air storage. The air storage room met all requirements stated in this specification. A Humboldt length comparator equipped with a digital dial gauge was used to determine the length change of the concrete specimens. The use of a digital

gauge helped reduce operator error and allowed more accurate measurements to be taken. The length comparator can be seen by looking at Figure 5.15.



Figure 5.15 – Humboldt Length Comparator, Mold, and Concrete Specimen

5.4.4 Permeability

The permeability of 4 x 8 inch concrete specimens was tested in accordance with ASTM C 1202 (1998), *Standard Test Method for Electrical Indication of Concrete's Ability to Resist Chloride Ion Penetration*. The purpose of this test was to give an indication of the concrete's permeability by determining the resistance to chloride ion penetration by electrical conductance. The equipment used in the laboratory to determine the permeability of the concrete specimens met all requirements set forth by this standard. Proove[®] It cells and a Model 164 Test Set with LED read outs, automatic shut off, and automatic processing equipment was used to determine the resistance of ion penetration

by electrical conductance. The Model 164 Test Set and Proove' It cells can be seen by looking at Figure 5.16.

The concrete specimens were allowed to cure in moist curing room until time of testing. Afterwards, the concrete specimens were removed from the moist cure room and a 2 +/- 1/8 inch slice was cut from the 4 x 8 inch specimen using a water-cooled diamond saw. The cut specimens were subsequently conditioned for testing according to requirements set forth by this standard. After conditioning was completed, the specimens were removed from the vacuum desiccator and placed into the Proove' It cells. The use of Proove' It cells allowed the rapid preparation of the concrete specimens after the removal from the desiccator. Furthermore, the Proove' It cells did not require the use of cell sealant, which further decreased the preparation time after removal from the desiccator. Each specimen was tested for a period of 6 hours as required by this standard.



Figure 5.16 – Model 164 Test Set and Proove' It Cells

CHAPTER 6

PRESENTATION AND ANALYSIS OF RESULTS

6.1 INTRODUCTION

The presentation and analysis of results is presented in this chapter in the following order:

- Phase I – Selection of Type and Dosage of HRWRA
- Phase II – Effect of Retarder Dosage
- Phase III – Appropriate SCC Mixing Procedure
- Phase IV – Selection of SCC Properties
- Phase V – Methods to Modify the Viscosity of SCC Mixtures

6.2 PHASE I – SELECTION OF TYPE AND DOSAGE OF HRWRA

The appropriate type and dosage of HRWRA was selected to provide a concrete mixture that was within the proposed quality control limits and that showed adequate fresh concrete properties after 30 minutes of continuous mixing. Table 6.1 and Figure 6.1 presents the results obtained from Phase I. Figure 6.1 shows that the slump flow increased as the dosage of Glenium 3030 NS increases; this is expected since the fluidity of a concrete mixture will increase as the HRWRA dosage increases. It can also be concluded from this figure that the Glenium 3000 NS appeared to be more effective at the same dosage amount of Glenium 3030 NS. Although the Glenium 3000 NS was more effective than the Glenium 3030 NS at the same dosage amount, it produced an undesirable thick-flakey film on top of cured specimens.

Table 6.1 and Figure 6.1 demonstrate that the slump flow decreased with continuous mixing. Thus, transportation time must be taken into consideration when

determining the appropriate HRWRA dosage. The results further indicate that dosages of 8 oz/cwt of Glenium 3000 NS and 10 oz/cwt Glenium 3030 NS were within the specified range of slump flow values of 21 ± 3 inches upon completion of mixing. The dosage of 8 oz/cwt of Glenium 3000 NS produced a concrete mixture with a VSI rating of 1.5 at a slump flow value of $23 \frac{3}{4}$ inches, a VSI rating that is not acceptable for this research project. On the other hand, a dosage amount of 10 oz/cwt of Glenium 3030 NS produced a concrete mixture that had appropriate fresh concrete properties after 30 minutes of continuous mixing. Based upon these results, it was determined that the appropriate type of HRWRA to be used throughout this research project should be Glenium 3030 NS, with a dosage amount of 10 oz/cwt to produce desirable fresh concrete properties after 30 minutes of continuous mixing under controlled laboratory conditions.

Table 6.1 – Fresh Concrete Properties for Phase I

Item		Batch ID			
		8 oz/cwt Glenium 3030 NS	8 oz/cwt Glenium 3000 NS	10 oz/cwt Glenium 3030 NS	12 oz/cwt Glenium 3030 NS
Plant	Slump Flow (inches)	21	31.5	27	30.5
	VSI	0	3	1.5	2.5
	T50 (sec.)	2.65	0.68	1.1	0.91
Job Site	Slump Flow (inches)	14	23.75	21	25
	VSI	0	1.5	1	1.5
	T50 (sec.)	>30	1.09	1.31	1.22
	Air Content (%)	3	3	*	*
	Temp. (°F)	77	77	75	81
	Unit Weight (lb/ft ³)	144.9	145.6	144	146.9

*The air content meter was not available for use.

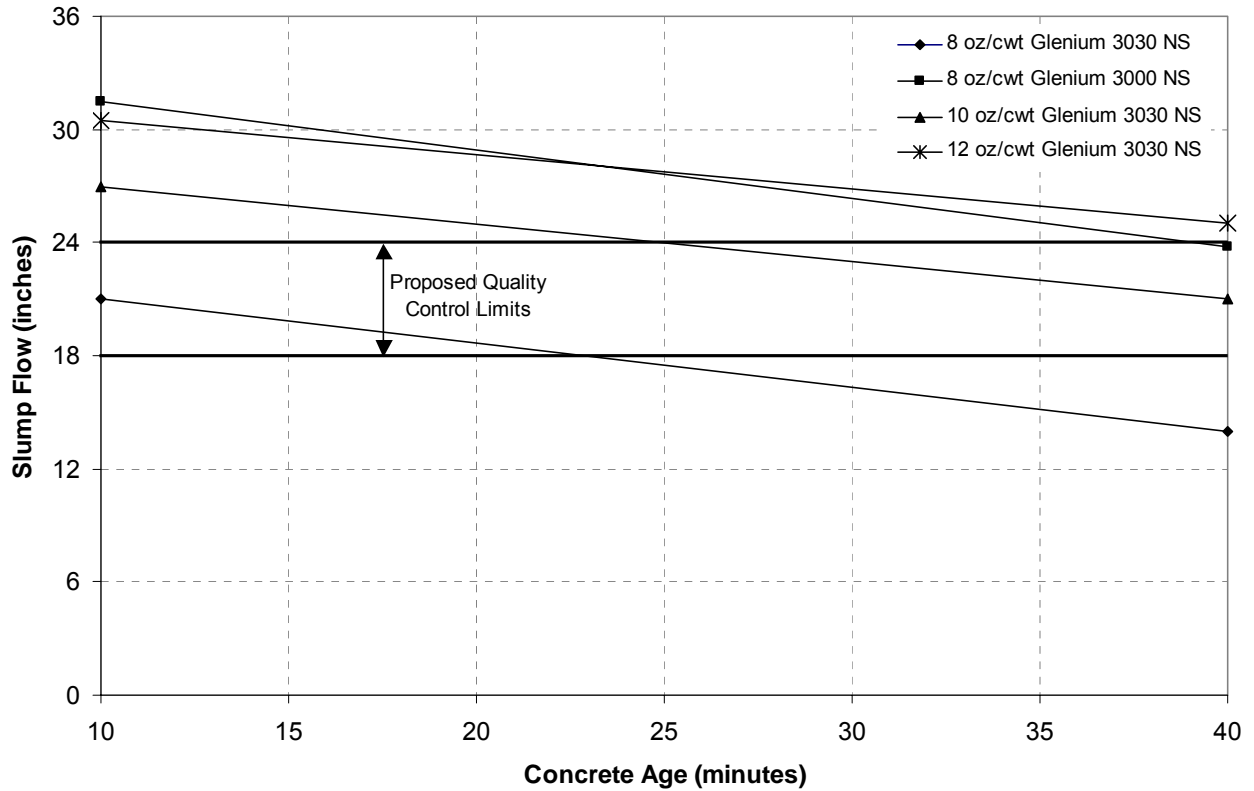


Figure 6.1 – Slump Flow vs. Concrete Age for Phase I

6.3 PHASE II – EFFECT OF RETARDER DOSAGE

In this phase, the effect of the retarding admixture on the retained workability was examined by varying the Delvo dosage from 0 oz/cwt to 8 oz/cwt in increments of 4 oz/cwt. Table 6.2 presents the fresh concrete properties obtained for Phase II. Figure 6.2 demonstrates how the slump flow varied with concrete age for each concrete batch, while Figure 6.3 shows the results obtained from the setting test.

From Figure 6.2, it is clear that retarding admixtures have an effect on the retained workability on the concrete mixtures. It can be seen that the concrete mixture that contained no retarding admixtures lost its workability at an incredibly rapid rate from a slump flow of 16 inches to a slump flow of 8 inches, which corresponds to a slump of 0

inches, within 3 hours after the first batch would have been placed. This rapid loss is undesirable for a drilled shaft concrete mixture in applications where retained workability is required. Figure 6.2 further reveals that the addition of 4 oz/cwt of Delvo was quite effective in increasing the time in which the concrete mixture remained workable. Figure 6.3 shows that 4 oz/cwt of Delvo extended the initial set of the concrete mixture from 364 minutes to 552 minutes (~ 3 hours). This corresponded to a slump increase from 0 inches after 3 hours to 5 inches (slump flow \approx 9.5 in.) after 4 $\frac{3}{4}$ hours.

By looking at Figure 6.3, the increase of Delvo dosage from 4 oz/cwt to 8 oz/cwt extended the initial set time from 552 minutes to 783 minutes (3 hours and 50 minutes). This increase in initial set corresponded to an increase of slump from 5 inches (slump flow \approx 9.5 in.) to 7 inches (slump flow \approx 11 in.) at approximately the same concrete age. Although the retained workability was increased, the change was less compared to the change from 0 oz/cwt to 4 oz/cwt or from 0 oz/cwt to 8 oz/cwt of Delvo.

It must be emphasized that the retained workability of concrete is not only a function of the extended initial set, but it is also a function of other factors such as temperature effects, long-term effectiveness of the HRWRA, and the effect of different supplementary cementitious materials on the hydration rate. Therefore, the dosage of retarding admixture should be sufficient to compensate for these effects and provide the extended initial necessary for the duration of the pour so that retained workability and shaft completion can be achieved. This phase has shown that the use of retarding admixtures can be very effective in extending the time in which the concrete mixture will remain workable.

Table 6.2 – Fresh Concrete Properties for Phase II

Item		Batch ID		
		0 oz/cwt Delvo	4 oz/cwt Delvo	8 oz/cwt Delvo
Plant	Slump Flow (inches)	25	28	29
	VSI	1	2	2
	T50 (sec.)	1.59	0.53	0.68
Job Site	Slump Flow (inches)	16	17.5	19
	VSI	0	1	1
	T50 (sec.)	>30	>30	>30
	Air Content (%)	2.7	2.8	2.8
	Temp. (°F)	71	72	71
	Unit Weight (lb/ft ³)	144	144.6	144

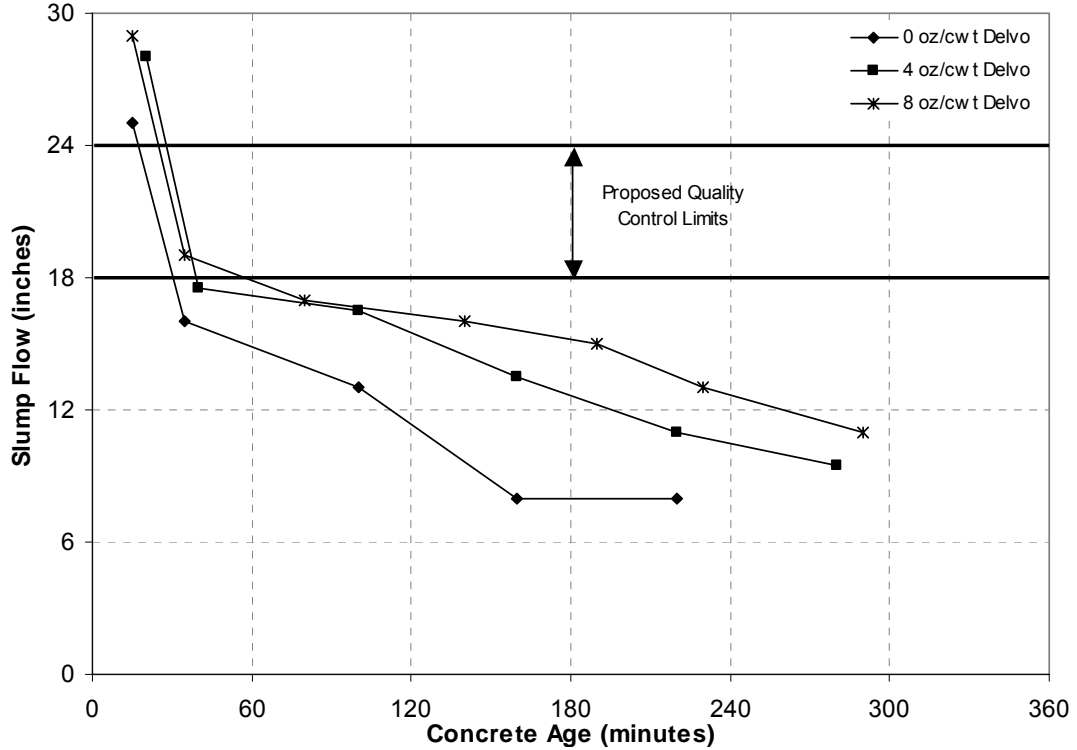


Figure 6.2 – Slump Flow vs. Concrete Age for Phase II

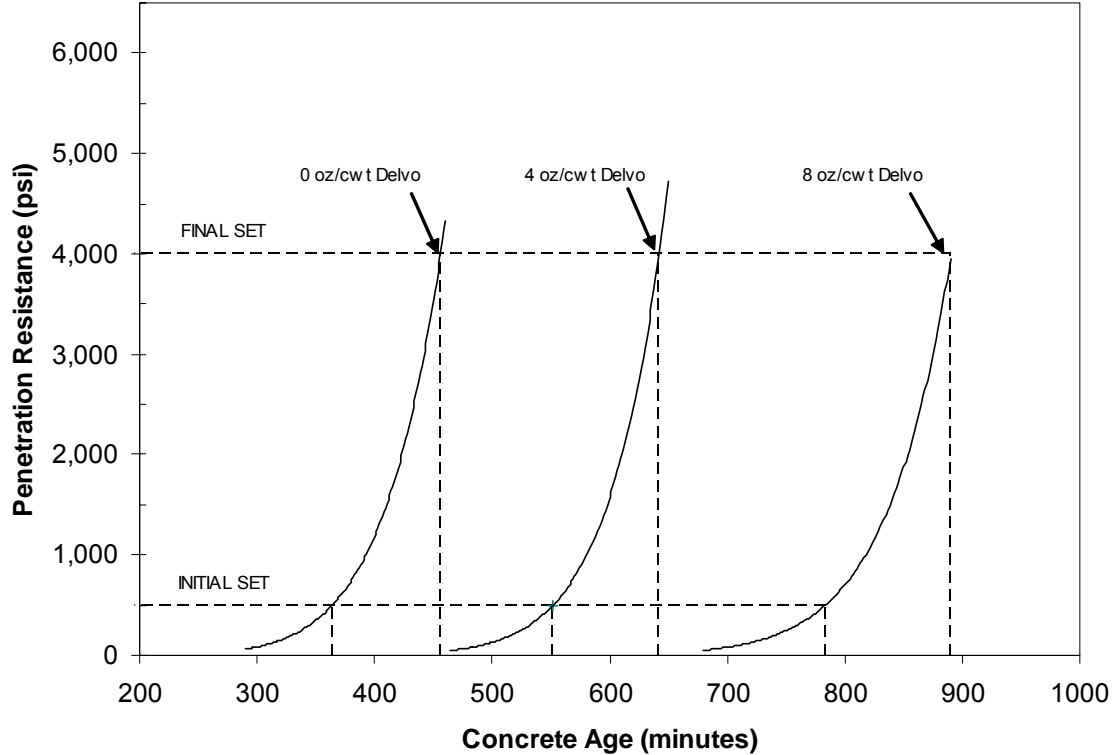


Figure 6.3 – Penetration Resistance vs. Concrete Age for Phase II

6.4 PHASE III - APPROPRIATE SCC MIXING PROCEDURE

In order to determine an appropriate SCC mixing procedure to be used throughout this research project, two different mixing procedures were compared in this phase. Table 6.3 presents the fresh concrete properties, while Figure 6.4 illustrates how the slump flow varied with concrete age for Phase III. It can be seen from these results that addition of the HRWRA before (mixing process 1) or after (mixing process 2) the addition of cementitious materials had no significant affect on the short or long term concrete workability. Based on these results, it was determined that mixing procedure 2 was the appropriate mixing procedure to be used throughout the laboratory portion of this research project. This decision was based on several factors that included the following:

- The determination of the water slump was relatively easy and quick to perform under laboratory conditions.
- By obtaining a water slump any excess free water due to inaccurate moisture corrections could be avoided.
- The water slump was an indicator of the concrete mixture’s consistency due to the mixing water alone. Later observations found that the stability of the SCC mixtures were sensitive to free water. Due to this fact, the water slump assisted in determining the appropriate mixture proportions to be used for several SCC mixtures.

Table 6.3 – Fresh Concrete Properties for Phase III

Item		Batch ID	
		Mixing Process 1	Mixing Process 2
Plant	Wet Slump (inches)	NA	4 3/4
	Slump Flow (inches)	27	26
	VSI	1.5	1.5
	T50 (sec.)	1.23	1.44
Job Site	Slump Flow (inches)	16	16.5
	VSI	0	0.5
	T50 (sec.)	>30	>30
	Air Content (%)	3.3	3.4
	Temp. (°F)	73	79
	Unit Weight (lb/ft ³)	145.2	144.5

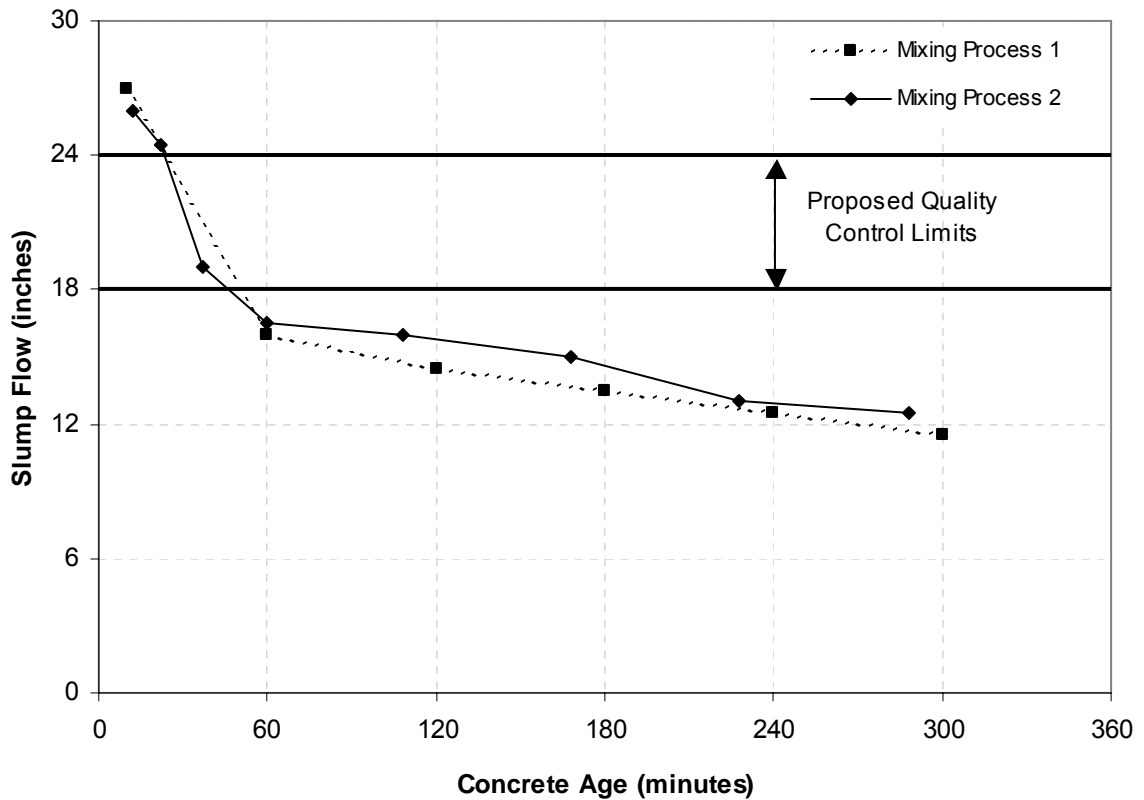


Figure 6.4 – Slump Flow vs. Concrete Age for Phase III

6.5 PHASE IV - SELECTION OF SCC PROPERTIES

6.5.1 Fresh Concrete Properties and Workability

The fresh concrete properties for both the ordinary drilled shaft concrete (ODSC) and SCC mixtures are presented in Tables 6.4 and 6.5. The data in Table 6.4 indicates that the ODSC mixtures were found to be within the specified range of slump values at placement in addition to demonstrating typical workability characteristics for wet-hole construction. As seen in Tables 6.4 and 6.5 the SCC mixtures typically contained more entrapped air than the ODSC mixtures. It is hypothesized that the HRWR admixture Glenium 3030 NS increased the entrapped air compared to the MRWR admixture PolyHeed N. Table 6.5 shows that no SCC mixtures possessed appropriate workability characteristics at the batch plant location. The SCC mixtures exhibited signs of

segregation by evidence of the VSI rating at higher slump flow values. However, after 50 minutes of continuous mixing the SCC mixtures were found to be within the specified quality control limits set forth in this research. The results further indicate that the stability of the SCC mixtures tends to increase as the water slump was reduced, as indicated by the differences among the VSI ratings for the SCC mixture, and especially for the silica fume and GGBFS mixtures at higher slump flow values.

Tables 6.4 and 6.5 reveal that the ODSC mixtures did not show an excessive loss of workability due to continuous mixing compared to the SCC mixtures. For instance, after 50 minutes of continuous mixing, the highest slump loss experienced by the ODSC mixtures was ½ inch compared to the least amount of slump flow loss by any SCC mixture of 6.5 inches. Thus, it is obvious that the SCC mixtures were more sensitive and experienced more workability loss when subjected to the same mixing conditions. Despite this issue, the SCC mixtures were capable of providing an increase in workability at placement compared to the ODSC mixtures. This enhanced workability is apparent in Figures 6.5 and 6.6.

Table 6.4 – Fresh Concrete Properties for ODSC Mixtures

Item		ODSC Mixtures	
		1:ODSC	2:ODSC
Plant	Slump (inches)	9	9
	Slump (inches)	8.5	8.75
Job Site	Air Content (%)	2.4	2
	Temp. (°F)	73	73
	Unit Weight (lb/ft ³)	146.7	146.5

Table 6.5 – Fresh Concrete Properties for SCC Mixtures

Item		Self-Consolidating Concrete Mixtures						
		3:41-48-FA	4:41-44-FA	5:41-40-FA	6:36-40-FA	7:36-40-SG	8:36-40-SF	9:36-44-FA
Plant	Slump Flow (inches)	29	30	30	30	27.5	26	28
	VSI	2.5	3	3	2	2	1.5	2
	T50 (sec.)	0.97	1.41	1.13	1.31	1.59	1.25	1.60
	Wet Slump (inches)	4	5	6	1.5	3/4	3/4	1.0
Job Site	Slump Flow (inches)	16.5	19.0	18.0	20.5	19.0	19.5	20.0
	VSI	1.0	1.0	1.0	0.5	0.5	0.5	0.5
	T50 (sec.)	>30	>30	>30	2.31	>30	>30	2.47
	Air Content (%)	3.8	3.5	4.2	3.5	4.5	5.1	3.8
	Temp. (°F)	73	71	74	77	77	79	76
	Unit Weight (lb/ft ³)	143.6	144.4	144.6	146.8	146	143.7	145.3



Figure 6.5 – Workability of ODSC Mixture (approximately 8.25 inches)



Figure 6.6 – Workability of SCC Mixture (approximately 20 inch slump flow)

Figures 6.7 and 6.8 present the slump or slump flow loss versus concrete age for the ODSC and SCC mixtures. Figure 6.7 shows that the ODSC mixtures displayed desirable slump retention characteristics in which the slump slowly diminished and exceeded 5.5 inches after 6 hours. This corresponded to a slump loss of 3 inches for 1:ODSC and 2:ODSC after placement. On the other hand, the slump flow loss for the SCC mixtures ranged from 6.5 to 10 inches after placement, which corresponds to a slump loss of more than 5 inches. Therefore, the SCC mixtures were more inclined to have a larger change in workability for the same amount of time compared to the ODSC mixtures. Although the SCC mixtures experienced larger changes in workability, the workability of the SCC mixtures was generally similar or higher than those of the ODSC mixtures after 5.5 to 6.5 hours as shown in Figure 6.9. It can be concluded from Figures 6.7 through 6.9 that at a concrete age of 5.5 to 6.5 hours both the ODSC and SCC mixtures would have complied with the recommendation provided by O'Neill and Reese (1999) that states that the drilled shaft concrete should have at least 4 inches of slump after 4 hours, but neither mixture would have met the recommendation provided by Brown (2004) that suggests that the drilled shaft concrete mixture should not experience a slump loss of no more than 2 inches for the duration of the pour. This is considering the fact that the duration of the pour was over 6 hours.

The data on Figure 6.8 indicate that the SCC mixtures that incorporated 4 oz/cwt of the mid-range water reducing admixture PolyHeed 1025 seem to maintain their workability better than those that contained only the Glenium 3030 NS. The SCC mixture 6:36-40-FA seems to be an outlier among this trend. Two primary factors are thought to have contributed to this outcome. Firstly, it is believed that the decrease in set

time for 6:36-40-FA mixture seen in Figure 6.10 may have increased the rate of slump flow loss. Moreover, after the mixing for the 6:36-40-FA mixture was complete, it was found that slump flow of the 6:36-40-FA mixture was very low. The mixture was re-dosed with 3 oz/cwt of Glenium 3030 NS to achieve a slump flow 20.5 inches, and as reported in Section 2.3.2 the workability regained from the re-dosage by HRWRA may decrease at a faster rate.

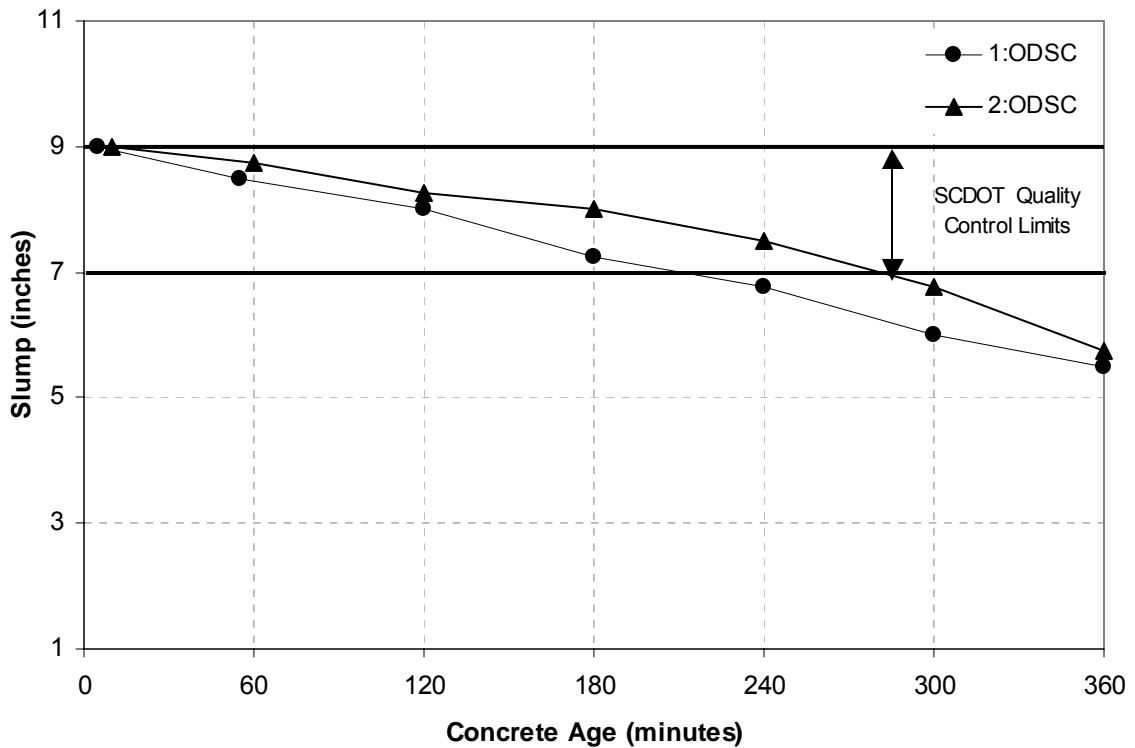


Figure 6.7 – Slump vs. Concrete Age

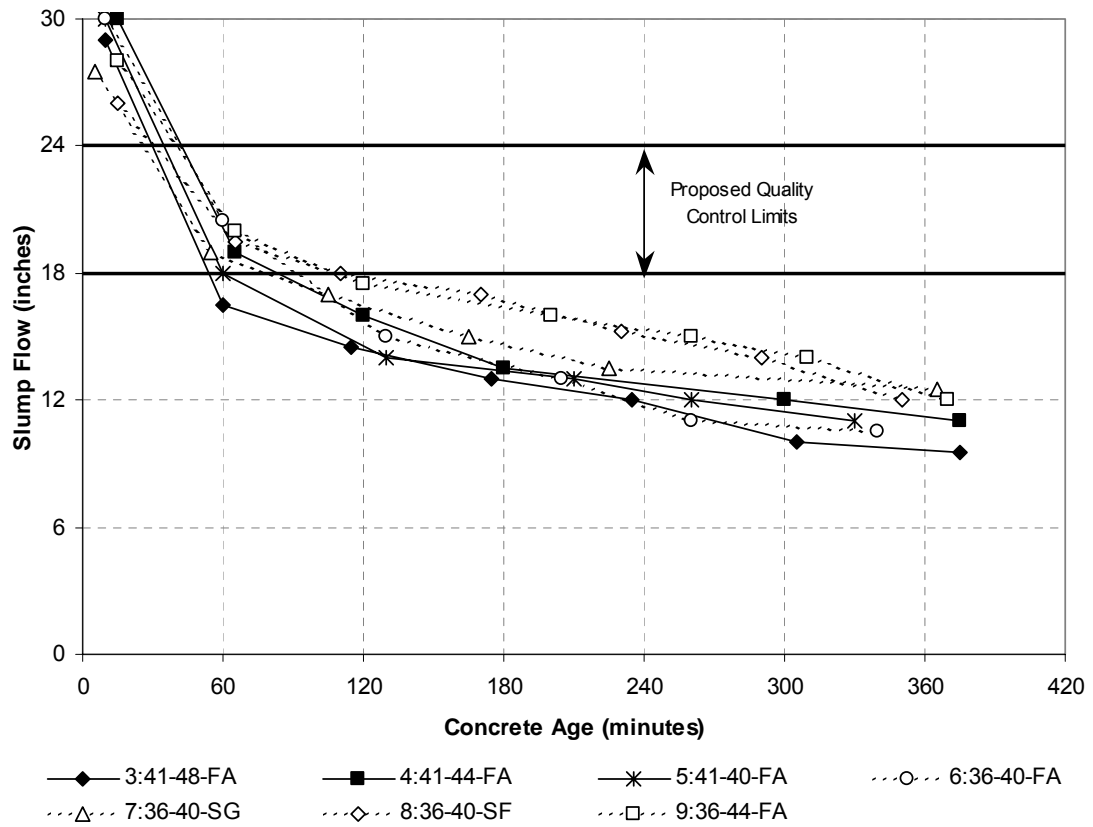


Figure 6.8 – Slump Flow vs. Concrete Age

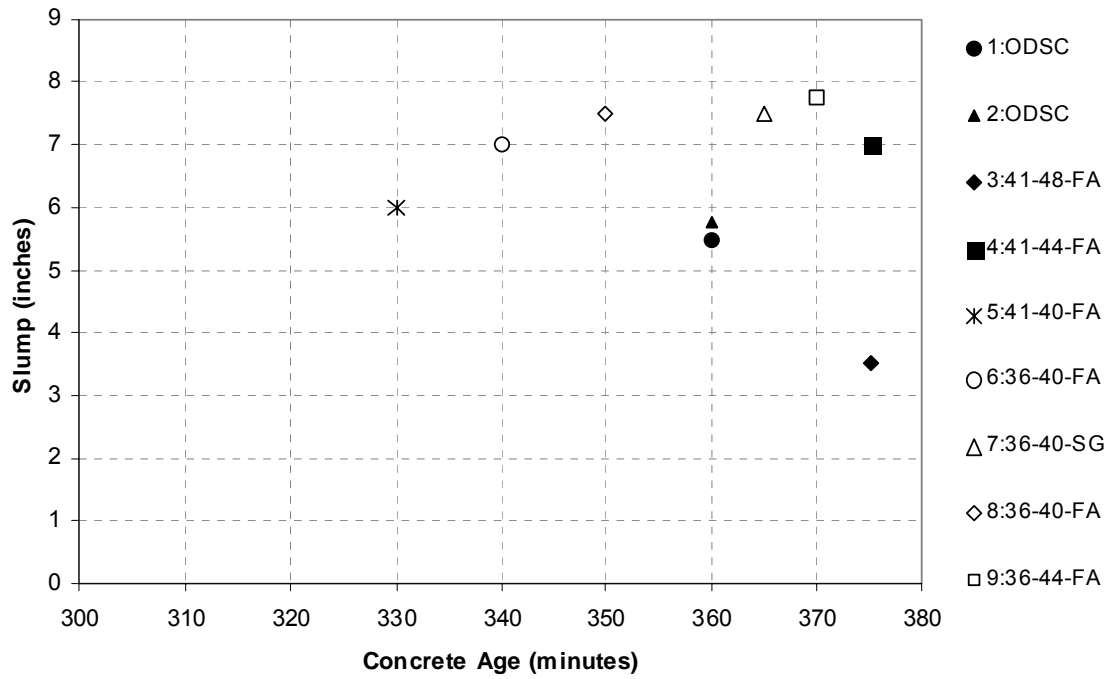


Figure 6.9 – Slump vs. Concrete Age for all Concrete Mixtures

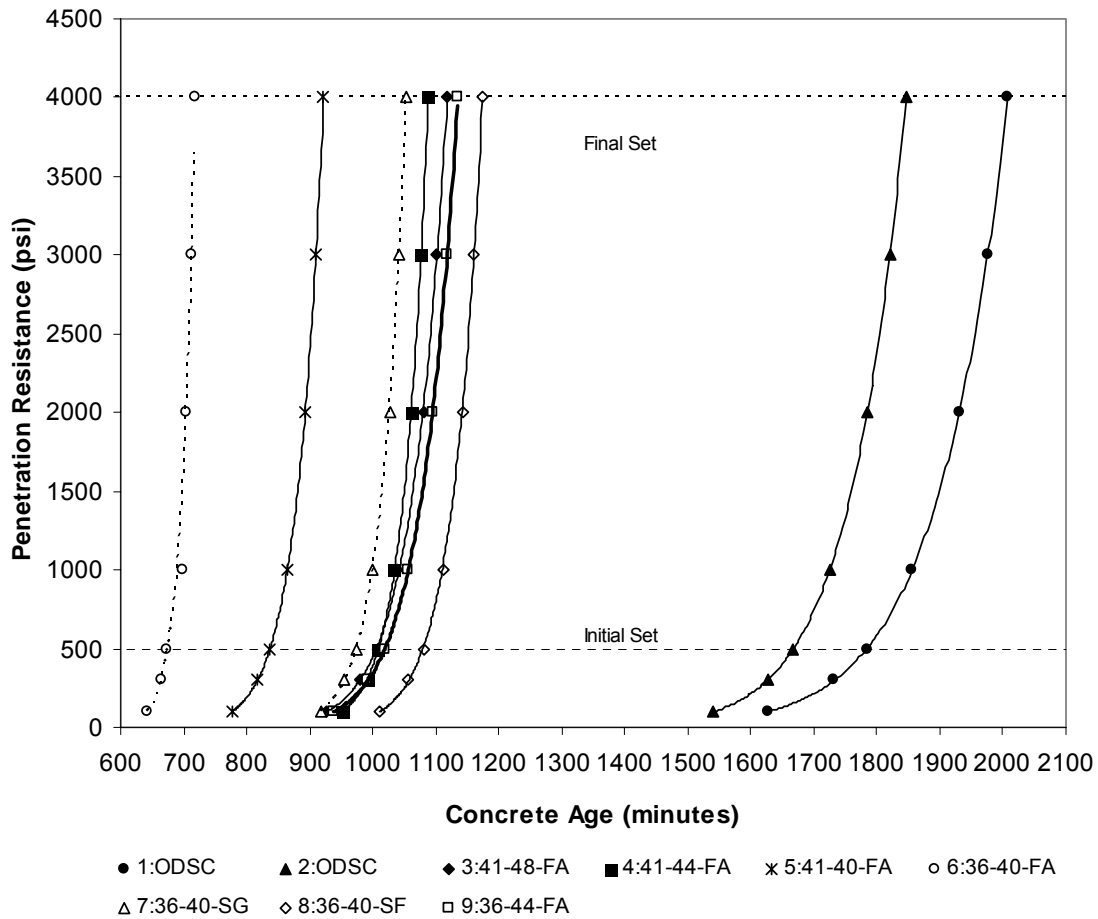


Figure 6.10 – Penetration Resistance vs. Concrete Age

6.5.2 Segregation and Bleeding Results

The results from the segregation column and bleeding tests are summarized in Table 6.6. The data on Tables 6.5 and 6.6 indicate that the SCC mixtures were placed into the column mold at the lower end of the proposed quality control limits and at a VSI rating of 1 or less. Under such conditions the SCC mixtures were stable and exhibited minimal segregation. However, the observed behavior of the SCC mixtures suggests that at higher values of slump flows and VSI ratings above 1 that the SCC mixtures would demonstrate a higher degree of segregation. For example, Table 6.5 shows that the fly ash (FA) SCC mixtures tested at the batch plant showed signs of segregation at higher

slump flow values. This segregation was evident by a thick mortar layer on the surface of the tested concrete in the mixing drum as well as clear evidence of segregation in the flow patty. Thus, it is reasonable to believe that if segregation column tests were performed under these conditions, the coarse aggregate concentration in the bottom sections would be higher, and the values of the segregation index would be increased.

Regarding the bleeding test, the ODSC mixtures demonstrated a higher degree of bleeding compared to the SCC mixtures prepared at the same water-to-cementitious materials ratio. It is thought that this higher degree of bleeding could possibly be due to the fact that the initial set for the ODSC mixtures was extended at least 9 hours compared to the SCC mixtures as shown in Figure 6.10. This allowed a much longer time frame in which the ODSC mixtures could bleed. Furthermore, the SCC mixtures typically contained a higher percentage of entrapped air, which is very effective in reducing bleeding. Lastly, the incorporation of the VMA for the SCC mixtures may have assisted in the reduction of bleed water. However, it should be noted that the influence of the new polyethylene glycol based VMAs on bleeding is not well known. Further evaluation of Table 6.6 reveals that the SCC mixtures prepared at a water-to-cementitious materials ratio of 0.36 limited the amount of bleeding.

Table 6.6 – Segregation and Bleeding Results

Mixture	Slump or Slump Flow (inches)	Segregation Index (%)	Bleeding (%)
1:ODSC	8.50	*	2.05
2:ODSC	8.75	*	2.34
3:41-48-FA	16.5	0.0379	0.33
4:41-44-FA	19	0.51	0.54
5:41-40-FA	18	0.41	0.77
6:36-40-FA	20.5	0.53	0**
7:36-40-SG	19	0.15	0**
8:36-40-SF	19.5	0.56	0**
9:36-44-FA	20	0.54	0**

* Not Conducted for ODSC Mixtures

**Bleeding was difficult to measure. Any water present at the surface was not clear and consisted primarily of cementitious materials.

6.5.3 Passing Ability: J-Ring and L-Box

The test results of the J-Ring and those of the L-Box are summarized in Table 6.7. Regarding the (FA) SCC mixtures, those prepared with sand-to-aggregate ratios of 0.44 and 0.48 exhibited greater passing ability among closely spaced reinforcement using the J-Ring than those prepared with a sand-to-aggregate ratio of 0.40. This could be due to the fact that the (FA) mixtures prepared at a sand-to-aggregate ratio of 0.40 contained a higher amount of coarse aggregate that increased the collision and interaction among the solid particles at the vicinity of the reinforcement that resulted in a greater tendency of blockage. The (SF) and (SG) mixtures prepared with a sand-to-aggregate ratio of 0.40 demonstrated a passing ability similar to the fly ash (FA) mixtures prepared with sand-to-aggregate ratios of 0.44 and 0.48. However, no other (SF) and (SG) mixtures were prepared at varying sand-to-aggregate ratio. Therefore, no conclusion can be drawn in

regards to if (SF) and (SG) mixtures prepared at higher sand-to-aggregate ratios would show greater passing ability at similar slump flows. It can be seen from Table 6.7 that all SCC mixtures demonstrated very low passing ability using the L-Box apparatus. This is due to the fact that the maximum size aggregate size of $\frac{3}{4}$ inch used for this research project was simply too large for the clear spacing between the reinforcement in the L-Box apparatus. For example, the clear spacing between the reinforcement for the L-Box as recommended by the PCI (2003) was 1.375 inches, which corresponds to less than 2 times the maximum aggregate size. This spacing is unrealistic for most drilled shaft applications, but if very congested reinforcement cages exist the L-Box could be used to ensure high passing ability of the SCC mixture. In case of this research, the L-Box apparatus was found to be ineffective in determining the passing ability of SCC mixtures designed for drilled shaft applications. As a result, the blocking ratios determined from the L-Box should be disregarded for this research.

Table 6.7 – Passing Ability Results for SCC Mixtures

	Slump Flow			J-Ring			L-Box
	Diameter (inches) Inverted	T ₅₀ (sec) Inverted	VSI	J-Ring Flow (inches) Inverted	Ratio of J-Ring Flow to Slump Flow	Passing Ability Rating	h ₂ /h ₁
3:41-48-FA	20	1.28	1	17.5	0.88	2	0.27
4:41-44-FA	20.5	2.13	1	18	0.88	2	0.3
5:41-40-FA	20	1.91	1	16	0.8	2	0.078
6:36-40-FA	20	3.9	0.5	16	0.8	2	0.059
7:36-40-SG	20.5	5.03	1	18	0.88	2	0
8:36-40-SF	22	1.69	0.5	20.5	0.93	1	0.087
9:36-44-FA	20.5	2.25	0.5	18	0.88	2	0.036

6.5.4 Compressive Strength

The results for the compressive strength testing for the ordinary drilled shaft concrete (ODSC) and SCC mixtures are given in Figure 6.11. Regarding the (FA) SCC mixtures, Figure 6.11 indicates that regardless of the water-to-cementitious materials ratio, it appears that the sand-to-aggregate ratio did not influence the strength development. Figure 6.11 further reveals that the SCC mixtures prepared at a water-to-cementitious materials ratio of 0.41 demonstrated slightly lower compressive strengths compared to those of the ODSC mixtures. However, the average difference among the compressive strengths is reduced as the SCC mixtures continue to hydrate. The average difference between the compressive strengths are 15.5%, 12%, 10.5%, 9%, and 6.5% at ages of 3, 7, 14, 28, and 56-day, respectively. It is thought that the slightly lower compressive strengths can be attributed to the following:

- The SCC mixtures contained 8% higher replacement percentage of cement by fly ash compared to the ODSC mixtures. Therefore, the amount of early heat evolution is decreased and in turn reduces the early age strength, but not the long term strength.
- Secondly, Mindess et al. (2003) reports that there is only enough calcium hydroxide in the paste in which the Class F fly ash can react to form calcium silicates. This would suggest higher replacement percentages of fly ash may result in unreacted ash causing a slight reduction in compressive strengths.

Further evaluation of Figure 6.11 shows that the reduction in water-to-cementitious materials ratio from 0.41 to 0.36 for the (FA) SCC mixtures increased the

compressive strength, on average, by 1600 psi at 28-days. This is expected since it is a well known fact that the compressive strength is increased as the water-to-cementitious materials ratio decreases. Furthermore, the use of the silica fume or ground granulated blast furnace slag (GGBFS) was found to increase the compressive strength compared to the (FA) SCC mixtures.

In addition to the continuing pozzolanic reaction between the amorphous silica in the silica fume and the calcium hydroxide, the high fineness of the silica fume allows the particles to pack densely between the cement particles and improves the interfacial transition zone. As a result, the silica fume greatly reduces the void spaces within the cement paste, and the bond of the cement paste with the aggregate is improved allowing the aggregate to better participate in stress transfer (Neville 1996). These contributions provided by the silica fume can be capable of generating higher compressive strength compared to the use of fly ash alone as in the case of this research.

Unlike fly ash, high replacements of GGBFS, with values ranging from 25-65%, can be utilized since GGBFS have cementitious properties of their own and only 10-20% of cement is needed for activation. The hydration of GGBFS produces primarily calcium silicates and produces less calcium hydroxide than portland cement alone in addition to showing some pozzolanic behavior (Neville 1996). Neville (1996) reports that progressive release of alkalis by the GGBFS along the formation calcium hydroxide by portland cement results in a continuing reaction of GGBFS over a long period of time. Thus, there is a long term strength gain associated with the GGBFS. For these reasons, high compressive strengths at higher replacement values of portland cement by GGBFS can be achieved as in the case of this research.

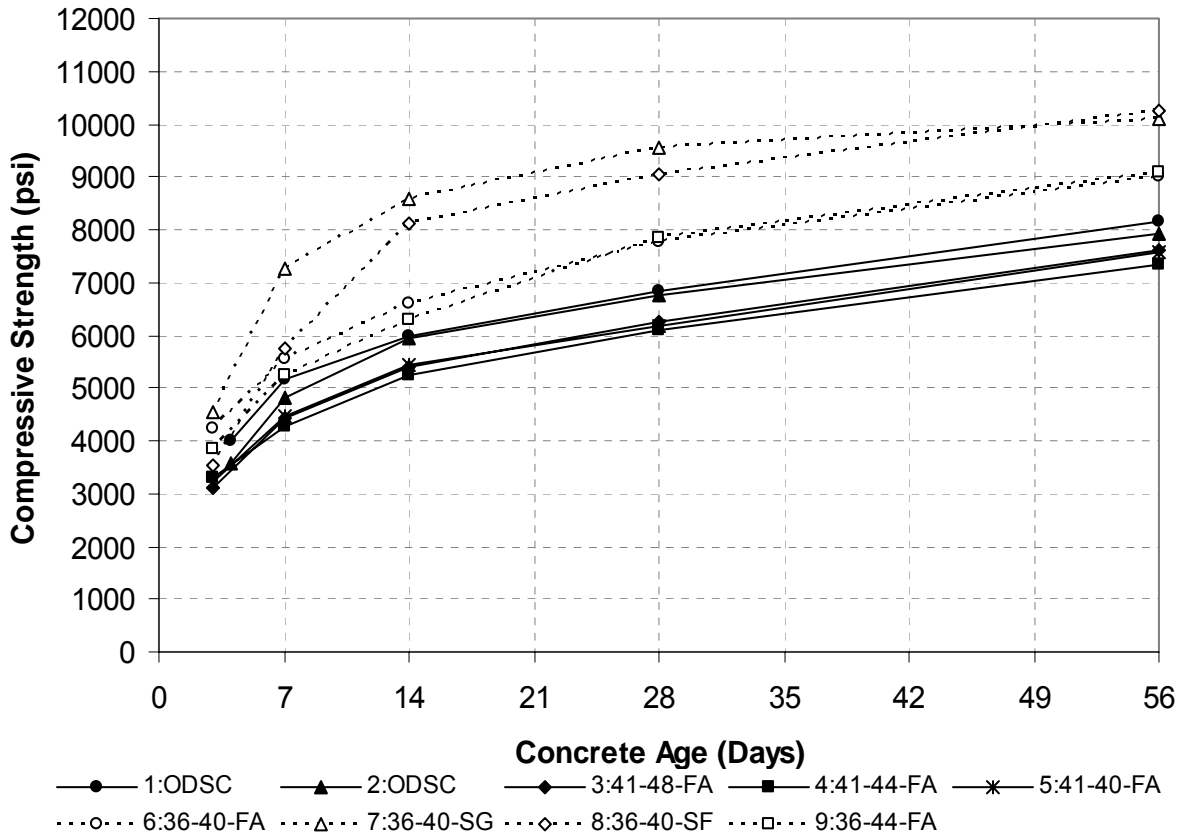


Figure 6.11 – Compressive Strength vs. Concrete Age for Phase IV

6.5.5 Modulus of Elasticity

The modulus of elasticity was determined for all concrete mixtures in conjunction with the compressive strength tests. Figure 6.12 presents the results obtained for the ordinary drilled shaft concrete (ODSC) and SCC mixtures. Generally speaking, the development for the modulus of elasticity is similar to the strength development provided in Figure 6.11. For example, the SCC mixtures prepared at a water-to-cementitious materials ratio of 0.41 demonstrated slightly lower elastic modulus values at early ages compared to those for the ODSC mixtures, and as the SCC mixtures continue to hydrate the difference among these mixtures are decreased. This should be expected

since the modulus of elasticity is a function of the compressive strength. This relationship between compressive strength and modulus of elasticity can further be seen by examining the silica fume and GGBFS mixtures. Figure 6.12 shows that the silica fume and GGBFS mixtures that exhibited higher compressive strengths also show higher modulus of elasticity values compared to the fly ash (FA) SCC mixtures at the same water-to-cementitious materials ratio. Furthermore, it appears from Figure 6.12 that the modulus of elasticity for the fly ash SCC mixtures was not significantly affected by the varying sand-to-aggregate ratio.

In order to determine if the calculated elastic modulus for the concrete mixtures is of typical sound concrete; the calculated modulus of elasticity in this research was compared with the ACI 318 (2002) Building Code ($E_c (psi) = 33 * W_c^{1.5} \sqrt{f'_c}$) and the ACI Committee 363 (2002) “State-of the-Art Report on High-Strength Concrete” ($E_c (psi) = 40,000\sqrt{f'_c} + 1,000,000$) models (see Chapter 2). These results are presented in Figures 6.13 and 6.14. Figure 6.13 reveals that the ACI 318 (2002) overestimated the modulus of elasticity for both the ODSC and SCC mixtures. Furthermore, the ACI 318 (2002) was found to increasingly overestimate the modulus of elasticity as the compressive strength increased. This finding coincides with ACI Committee 363 (2002) that found that the equation used by the ACI 318 (2002) was only valid for compressive strengths up to 6,000 psi. On the other hand, the ACI Committee 363 (2002) equation provided an improved and typically a conservative estimate for the modulus of elasticity for both the ODSC and SCC mixtures as shown in Figure 6.14. It is believed that the improved and conservative estimation for the modulus of elasticity lies in the fact that the

equation provided by the ACI Committee 363 (2002) is valid for compressive strengths from 3,000 to 12,000 psi.

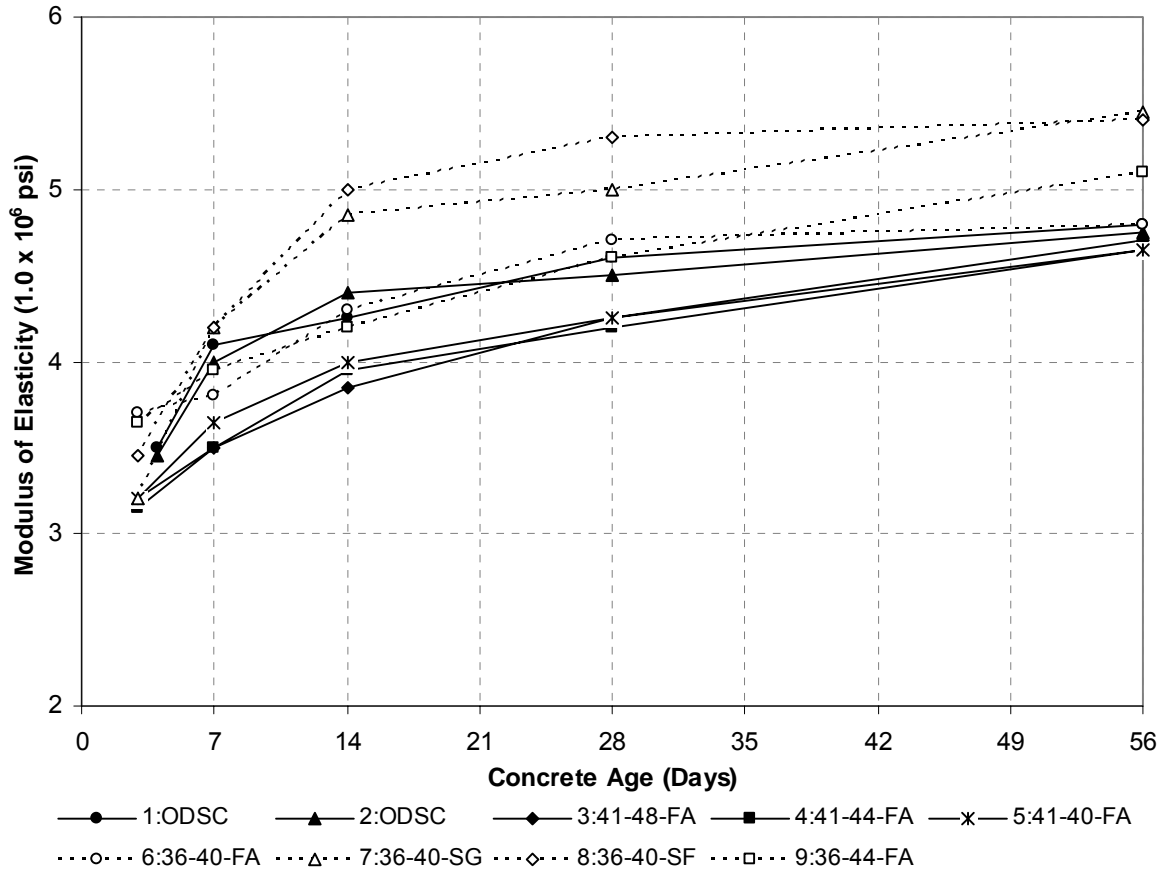


Figure 6.12 – Modulus of Elasticity vs. Concrete Age for Phase IV

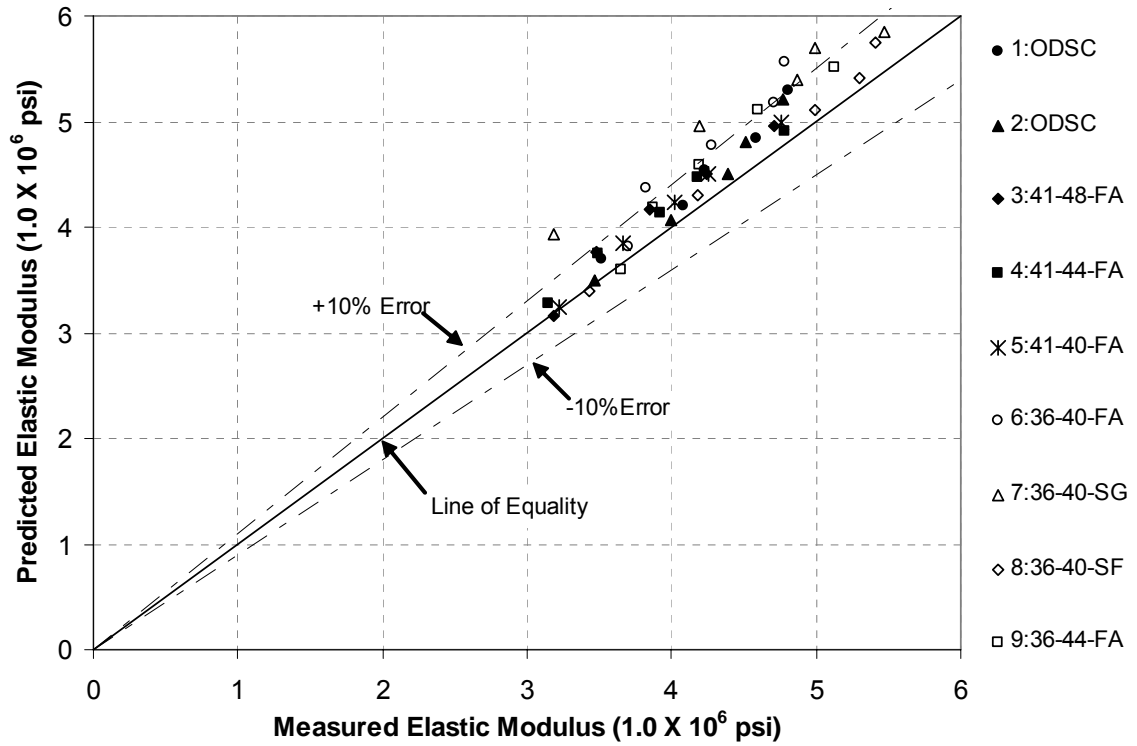


Figure 6.13 – Predicted vs. Measured Elastic Modulus according to ACI 318 (2002) Equation for Phase IV

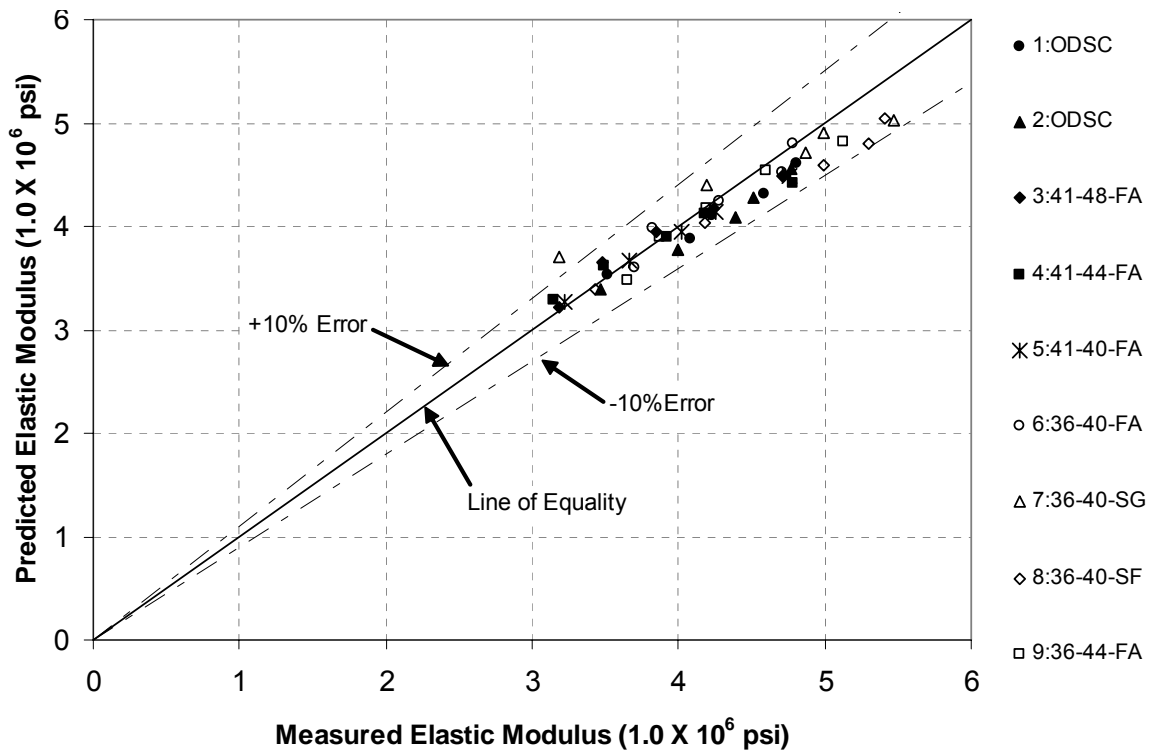


Figure 6.14 – Predicted vs. Measured Elastic Modulus According to ACI 363(2002) Equation for Phase IV

6.5.6 Drying Shrinkage

The drying shrinkage results for the ordinary drilled shaft concrete (ODSC) and SCC mixtures are presented in Figure 6.15. The data on Figure 6.15 indicate that the water-to-cementitious materials ratio appears to be the main factor influencing the amount of drying shrinkage. The results show that the reduction in water-to-cementitious materials ratio from 0.41 to 0.36 decreased the specimen's tendency to shrink. This trend should be expected since the drying shrinkage is known to be reduced as the water-to-cementitious materials ratio is decreased. However, it appears that the mixture prepared with ground granulated blast furnace slag (SG mixture) produced slightly higher drying shrinkage values compared to the other mixtures prepared at a water-to-cementitious materials ratio of 0.36.

Among the SCC mixtures prepared at a water-to-cementitious materials ratio of 0.41, the results indicate the SCC mixture prepared at sand-to-aggregate ratio of 0.48 shows evidence of higher drying shrinkage than those prepared at 0.40 and 0.44 as well as the highest drying shrinkage overall. However, the difference in drying shrinkage values among these SCC mixtures is actually quite minimal and operator or equipment error could very easily alter this outcome. This data suggest that the SCC mixtures prepared at a water-to-cementitious materials ratio of 0.41 exhibited drying shrinkage values similar to the ODSC mixtures. This outcome is reasonable given the fact that the paste volume fraction and aggregate volume fraction did not significantly vary compared to the SCC mixtures. Furthermore, Figure 6.15 indicates that the two ODSC mixtures showed practically the same drying shrinkage characteristics throughout the test. This

indicates that use of the #789 coarse aggregate gradation for 1: ODSC had no significant effect on the drying shrinkage values.

Unfortunately, no absolute conclusion can be made at this time concerning the effect of the sand-to-aggregate ratio on the drying shrinkage, due to the lack of drying shrinkage data for 9:36:44-FA. It must be noted that this research will be updated as soon as additional test results are available.

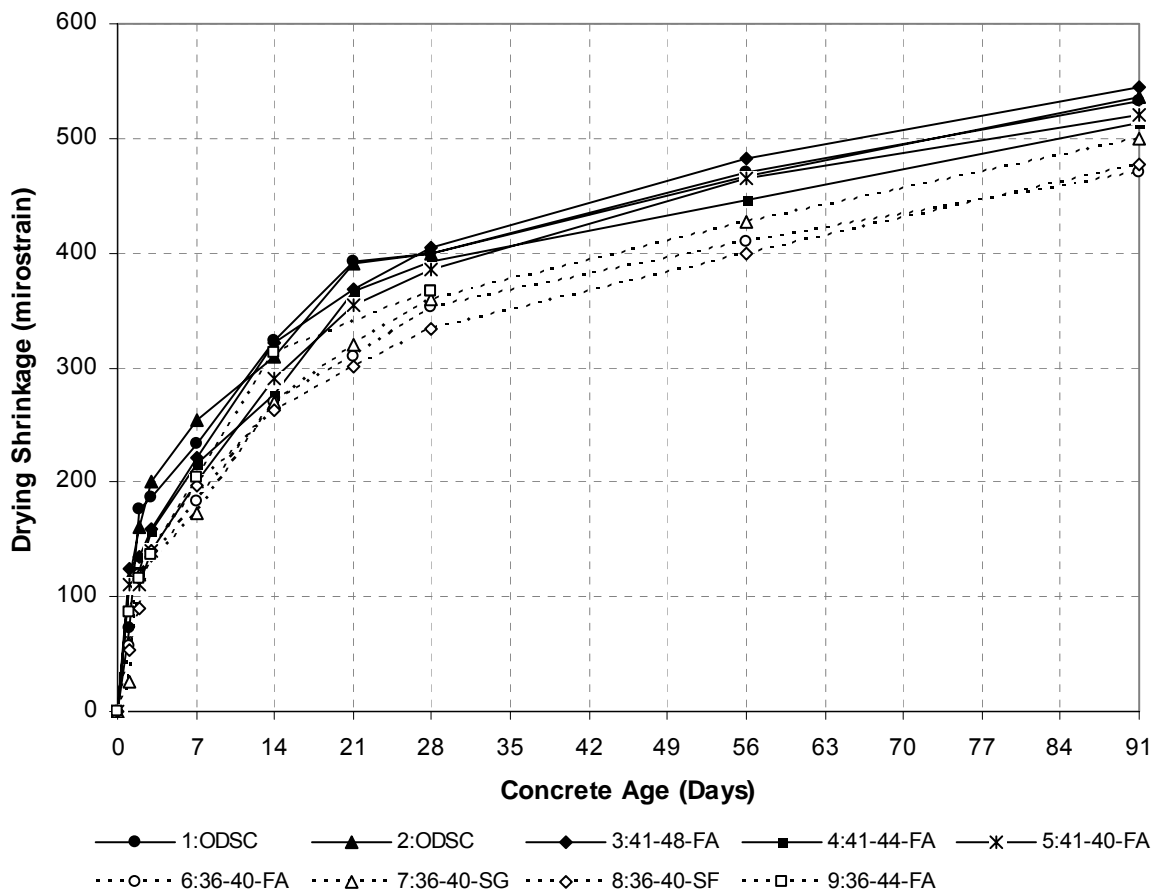


Figure 6.15 – Drying Shrinkage vs. Concrete Age

6.5.7 Permeability

Results of the rapid chloride permeability tests (RCPT) for the ordinary drilled shaft concrete (ODSC) and SCC mixtures are given in Figures 6.16 and 6.17. The RCPT values at 91-days for the ordinary drilled shaft concrete mixtures were 4530 and 4562 as compared to 2584, 2773, and 3067 for the SCC mixtures at the same water-to-cementitious materials ratio. This reduction in RCPT values for the SCC mixtures can be attributed to the fact the SCC mixtures contained a higher replacement percentage of fly ash (FA). For example, the SCC mixtures with a water-to-cementitious materials ratio of 0.41 consisted of 33% replacement of cement by fly ash, where as the ODSC mixtures only contained 25% replacement of cement by fly ash. Since fly ash is notably more spherical than cement, the additional replacement of fly ash may have allowed the particles to pack more tightly within the pore spaces creating a denser microstructure.

Figures 6.16 and 6.17 indicate that the RCPT values were found to decrease from 91 to 365-days. As the hydration process proceeds, the interconnected pores that were present at 91-days are being filled by the continuous formation of C-S-H and the continuous growth of the calcium hydroxide within the capillaries pores. As a result, the porosity of the paste will decrease with time lowering the RCPT values. It is also important to notice that the trends from Figure 6.16 are also present in Figure 6.17. At 365-days the ODSC mixtures still exhibited higher RCPT values compared to the SCC mixtures at the same water-to-cementitious materials ratio.

As discussed in Section 2.4.4, the coefficient of permeability decreases as the water-to-cementitious materials ratio is reduced. The reduction in RCPT values for the fly ash (FA) SCC mixtures (particularly 3:41-48-FA, 6:36-40-FA, and 9:36-44-FA) due

to the decrease in water-to-cementitious materials ratio is evident on Figure 6.16. The reduction in water-to-cementitious materials ratio from 0.41 to 0.36 decreased the RCPT values, on average, 1500 coulombs at the same concrete age.

It is also important to emphasize the effect of the supplementary cementitious material on the RCPT values at a water-to-cementitious materials ratio of 0.36. Figure 6.16 indicates that the introduction of silica fume considerably reduced the RCPT values compared to the (FA) mixtures. This reduction in RCPT values comes from the ability of the silica fume to pack tightly between pore spaces creating a very dense microstructure. However, the introduction of ground granulated blast furnace slag (GGBFS) increased the RCPT values compared to the fly ash (FA) SCC mixtures. The increase in RCPT values for the (SG) mixture may stem from the angular shape of the GGBFS compared to the spherical nature of the fly ash. Due to this fact, the particles may have not been able to pack as closely causing an increase in the interconnected capillary pores.

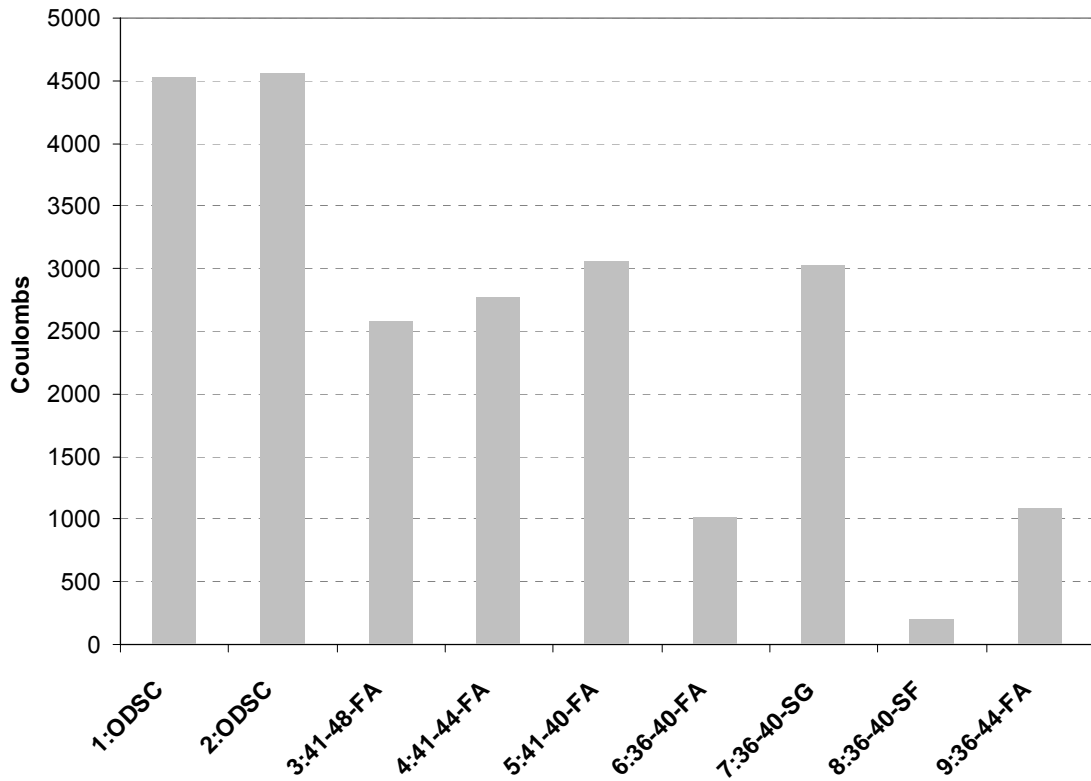


Figure 6.16 – 91-Day Permeability Results

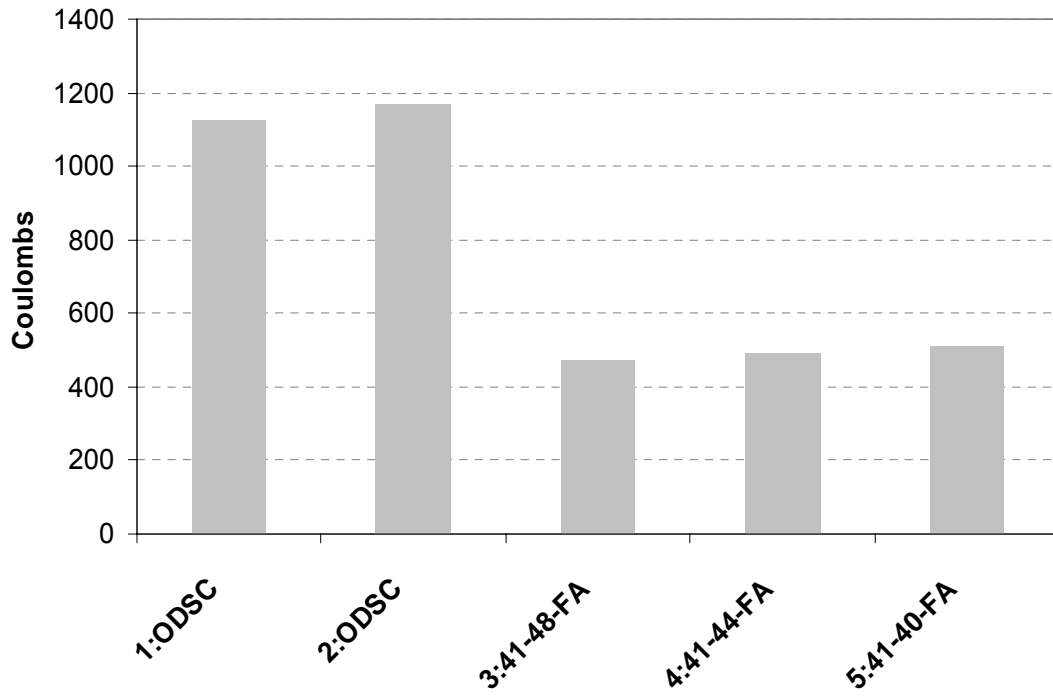


Figure 6.17 – 365-Day Permeability Results

6.5.8 Comparison between Laboratory and Field Conditions

A small scale field study was conducted at APAC Ready Mix Concrete in Marion, South Carolina. The primary objectives of this field study were three fold:

1. To ensure that the chemical admixture dosages determined for laboratory conditions remain sufficient for field conditions.
2. To evaluate the effect of mixing imposed by a ready mix truck on the slump flow after 50 minutes of continuous mixing.
3. To compare the compressive strength and modulus of elasticity values obtained from the field specimens to that of the laboratory specimens.

The two SCC mixtures selected to be used for this field study were 3:41-48-FA and 6:36-40-FA. The SCC mixtures were selected based upon the fact that at the time of this field study these mixtures were considered to be the most likely utilized for the full-scale field project. The only modification to these mixtures was that an additional 2 oz/cwt of Delvo was added to account for the effect of hot weather conditions on slump retention and time of setting. No ODSC mixtures were selected to be tested for this field study considering the fact that the ODSC mixtures used for laboratory purposes have been routinely accepted in South Carolina. The raw materials and chemical admixtures used for this small scale field study were provided by the same suppliers as those from the laboratory materials.

Batching and Mixing: Each SCC mixture consisted of two cubic yards of concrete that was batched and mixed according to normal operations of the plant with the exception of the chemical admixtures. Figures 6.18 through 6.21 demonstrate how the raw materials were obtained and batched at this ready mix concrete plant. The chemical admixtures

were added to the SCC mixtures after the ready mix truck exited the material hopper and wash down was performed. This was done for two primary reasons. Firstly, the chemical admixtures needed for the SCC mixtures were not available for automated dispensing since they were not used in everyday operation. Secondly, the chemical admixtures were added after the wash down process was performed in order to obtain a water slump. Generally, 3 to 5 gallons of water is typically used for the wash down process. This extra water must be taken into account in the batching process since the stability of the SCC mixtures was found to be sensitive to excessive free water. The researcher requested that the plant operator withhold 5 gallons of batching water to account for the wash down process.

A water slump was taken after the batching and wash down process was completed. It was found that obtaining a water slump under field conditions required a significant increase in time compared to laboratory conditions. Under laboratory conditions the water slump could be obtained no more than 5 minutes after water-to-cementitious materials contact; however, under field conditions obtaining the water slump required no less than 30 minutes after water-to-cementitious materials contact. This was primarily due to the time required to perform the wash down process and obtaining a concrete sample for testing. Unlike laboratory conditions where the concrete sample is very accessible and easy to obtain from the mixer, obtaining the concrete sample from the ready mix truck required more equipment, people, time, and attentiveness to detail due to safety precautions. Alternatives to this approach could be employed in order to reduce the time in which the accuracy of the moisture corrections can be determined. The following procedure could be utilized to accomplish this goal:

1. The use of wash down water could be prohibited in cases where SCC mixtures are used in order to control unwanted water. By implementing this suggestion no water will have to be withheld to account for the wash down process, and the time required to check the accuracy of the moisture corrections can be reduced.
2. It may be possible to check the accuracy of the moisture corrections without having to obtain a concrete sample. This can be accomplished by rotating the concrete mixture toward the concrete chute and make a water slump estimate based on the observation of the wetness or dryness of the concrete mixture. Most experienced quality control individuals can provide a reasonable estimate of the water slump, typically within +/- 1 inch of the actual water slump.



Figure 6.18 – Attaining Raw Materials from Stock Piles



Figure 6.19 – Unloading Raw Materials onto Conveyer Belt



Figure 6.20 - Raw Materials being Delivered to Hopper via Conveyer Belt



Figure 6.21 – Raw Materials being Mixed by Ready Mix Truck

Fresh Concrete Properties: The fresh concrete properties for the field study are presented in Table 6.8 and Figure 6.22. The fresh concrete properties for the plant location were very similar to those of the laboratory, suggesting that the batch sizes utilized for laboratory evaluation were sufficient to simulate the performance of the chemical admixtures in large batches. However, the slump flow characteristics for the job site location between the laboratory and field conditions produced very different results. It must be noted that in Figure 6.22 the mixing time represents the time of mixing after the first slump flow was taken. This was necessary due to the substantial difference in times for obtaining the water slump. The data in Table 6.8 and Figure 6.22 indicate that the slump flow loss due to continuous mixing was much less under field conditions compared to the laboratory. The primary reason for this outcome is likely due to the rotational speed of the mixing drum for the ready mix truck compared to laboratory

mixer. The laboratory mixer was rotated at a higher speed, providing heavy agitation of the concrete mixture. Where as, the mixing drum for the ready mix truck was set to 4-5 rotations per minute. The larger batch size used for the field study may have also contributed to lower slump loss for the field study.

After 50 minutes of continuous mixing, the slump flow was found to be outside the proposed quality control limits. The SCC mixtures were allowed to rotate at an increased rotational speed for a short duration until the slump flow was found to be within the proposed quality control limits. The slump flow at which cylindrical specimens were made for the hardened concrete properties was 20 inches for 3:41-48-FA and 21 inches for 6:36-40-FA.

Table 6.8 - Fresh Concrete Properties for both Laboratory and Field Conditions

Item		Self-Consolidating Concrete Mixture			
		3:41-48-FA (Lab)	3:41-48-FA (Field)	6:36-40-FA (Lab)	6:36-40-FA (Field)
Plant	Slump Flow (inches)	29	30	30	28
	VSI	2.5	2.5	2	2.5
	T50 (sec.)	0.93	1.53	1.31	2.53
	Wet Slump (inches)	4	≈ 3	1.5	≈ 1
Job Site	Slump Flow (inches)	16.5	27.5	20.5	26
	VSI	1	1.5	0.5	1.5
	T50 (sec.)	>30	1.62	2.31	3.5
	Air Content (%)	3.8	3.1	3.46	3.1
	Temp. (°F)	73	96	75	100

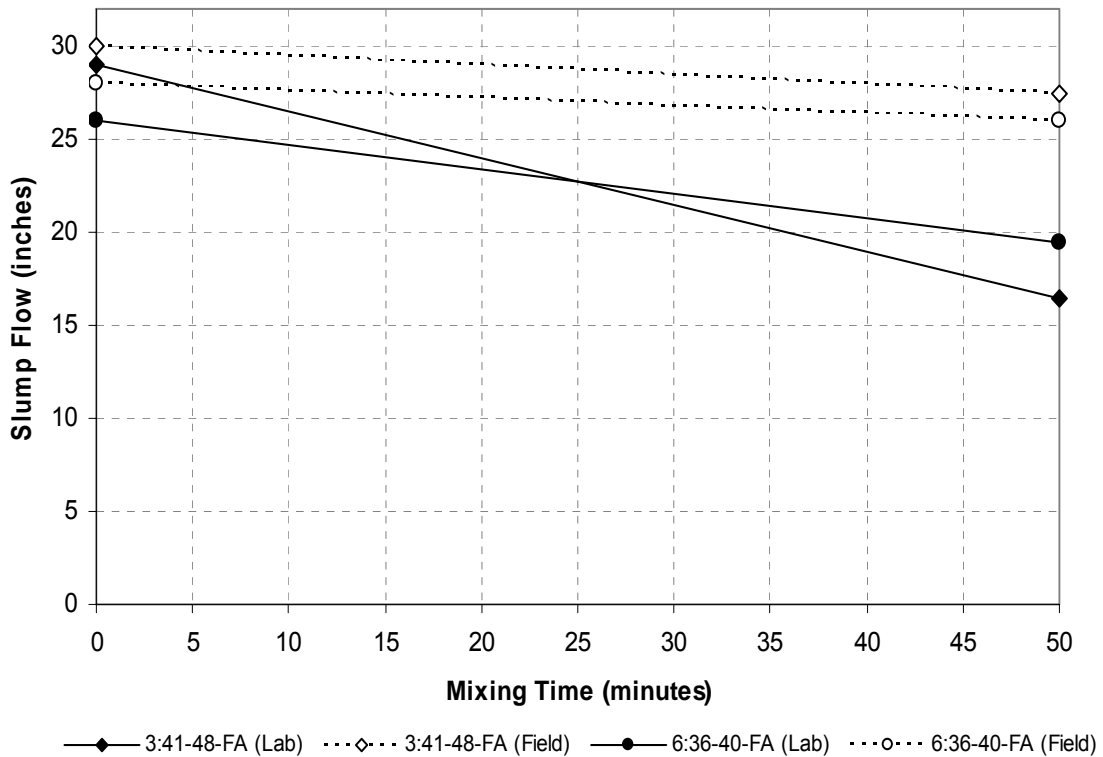


Figure 6.22 – Slump Flow vs. Mixing Time under Laboratory and Field Conditions

The concrete temperatures in the field were higher than those for the laboratory as indicated in Table 6.8. Prolonged exposure to high temperatures can be detrimental to the slump retention and can significantly decrease setting times. In order to monitor the temperatures for the concrete samples for the slump retention and setting test, an I-Button was placed beside the samples until testing was complete. The temperature profile attained from the I-Button is presented in Figure 6.23. The times specified on Figure 6.23 are of those in which the first SCC mixture was made until the last setting test was complete. The SCC mixture 3:41-48-FA was batched on 7/27/04 at 10:45 AM and 6:36-40-FA on 7/27/04 at 2:35 PM. Figure 6.23 further reveals that the concrete samples were exposed to temperatures ranging from 76 to 113 degrees °F. The corresponding setting test results for the field specimens are presented in Figure 6.24. From this figure it can be determined that the SCC mixture 3:41-48-FA under field conditions experienced much

faster setting times as compared to the laboratory conditions. The SCC mixture 6:36-40-FA demonstrated similar set times under field conditions compared to laboratory conditions. The faster set time for 3:41-48-FA may be due to longer exposure to high temperatures compared to 6:36-40-FA that experienced high temperatures for a short duration followed by a sharp decrease in temperature.

The slump retention for 3:41-48-FA was also affected by the high temperatures and faster set times. The slump flow retention for 3:41-48-FA was determined to be 8 inches after four hours, which corresponded to a slump of approximately 3 ½ inches. This slump was found to be much less than the laboratory specimen at approximately the same concrete age. On the other hand, the slump flow for 6:36-40-FA was determined to be 10 inches after 4 hours, which corresponded to a slump of 6 inches. This slump flow was found to be slightly less than under laboratory conditions even with similar set times. These results would suggest that even with similar set times the rate of slump loss is increased when exposed to high temperatures. These results further indicate the need for testing to determine the amount of additional retarder needed to account for high temperatures to ensure that proper retained workability and set times are achieved.

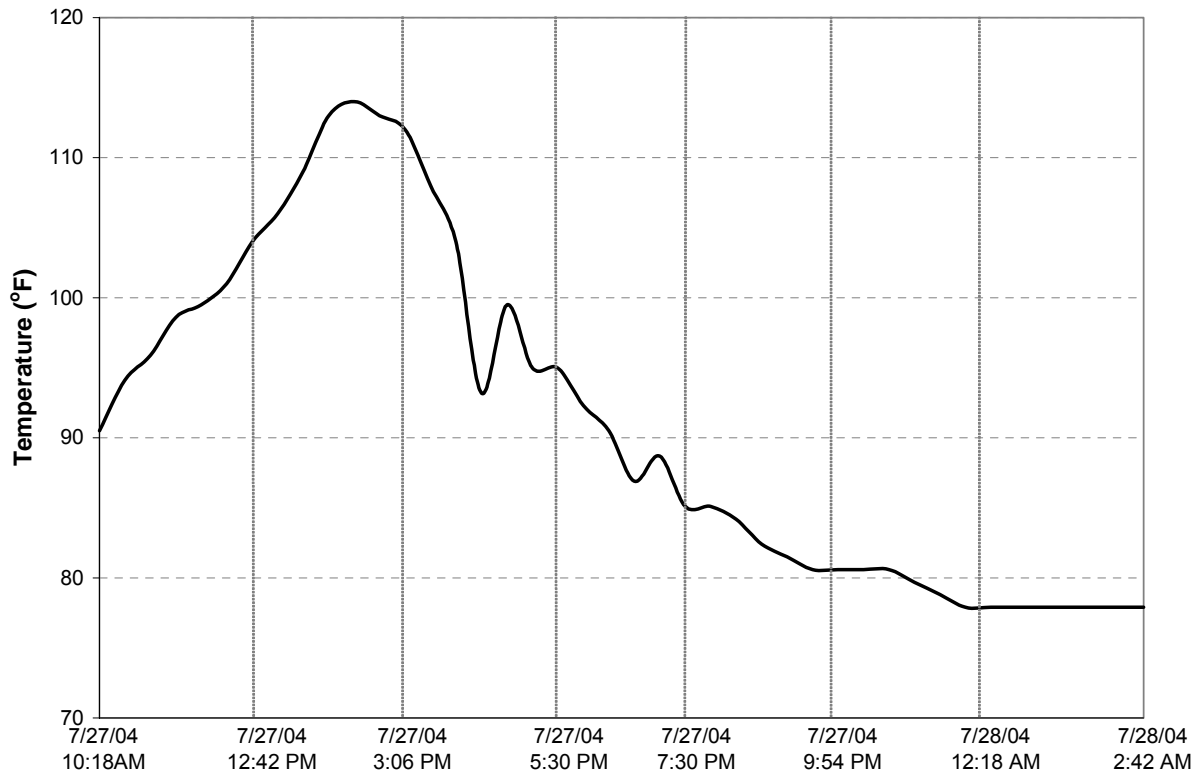


Figure 6.23 – Temperature Profile Obtained from I-Button

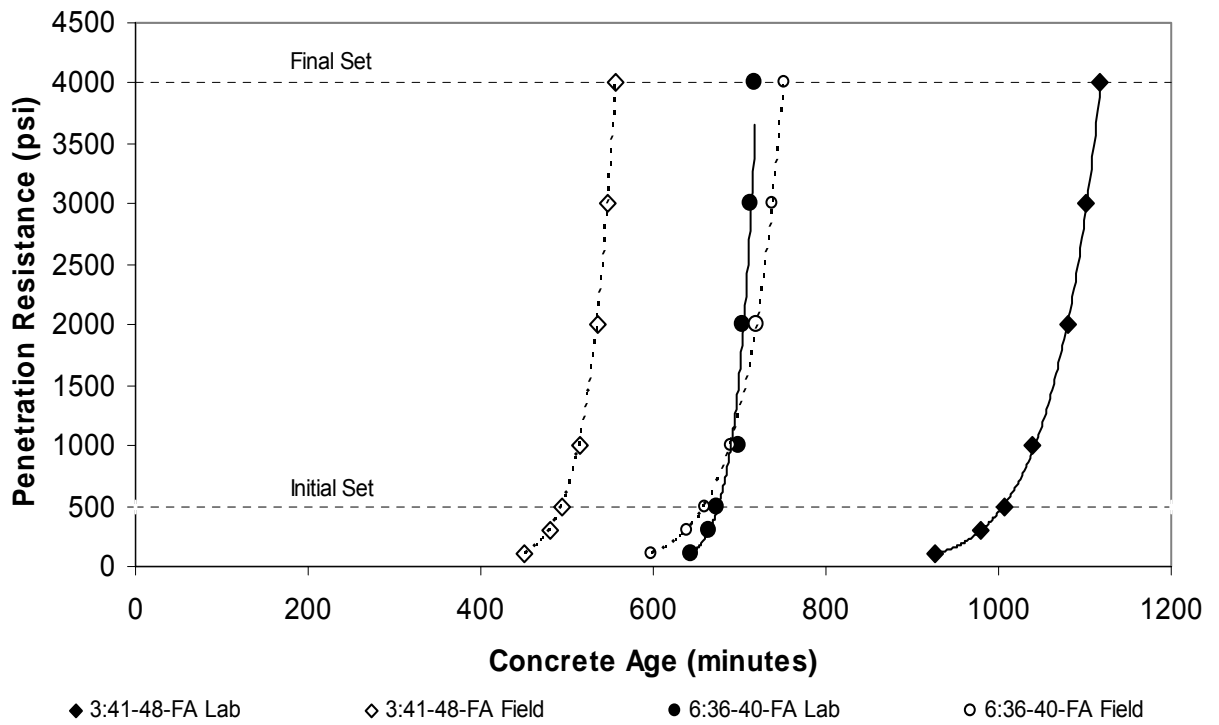


Figure 6.24 – Penetration Resistance vs. Concrete Age under Laboratory and Field Conditions

Hardened Concrete Properties: The results for the compressive strength and modulus of elasticity for both SCC mixtures are given in Figures 6.25 and 6.26. The data collected from the compressive strength and modulus of elasticity allowed for a comparison between field and laboratory conditions. It was found that the field specimens exhibited slightly higher compressive strengths compared to the laboratory specimens. It is thought that the higher compressive strengths are due to possibly withholding extra water for the wash down process, which may have caused a reduction in water-to-cementitious materials ratio. Nevertheless, the compressive strength and modulus of elasticity values obtained from the field specimens corresponded well to those obtained from the laboratory.

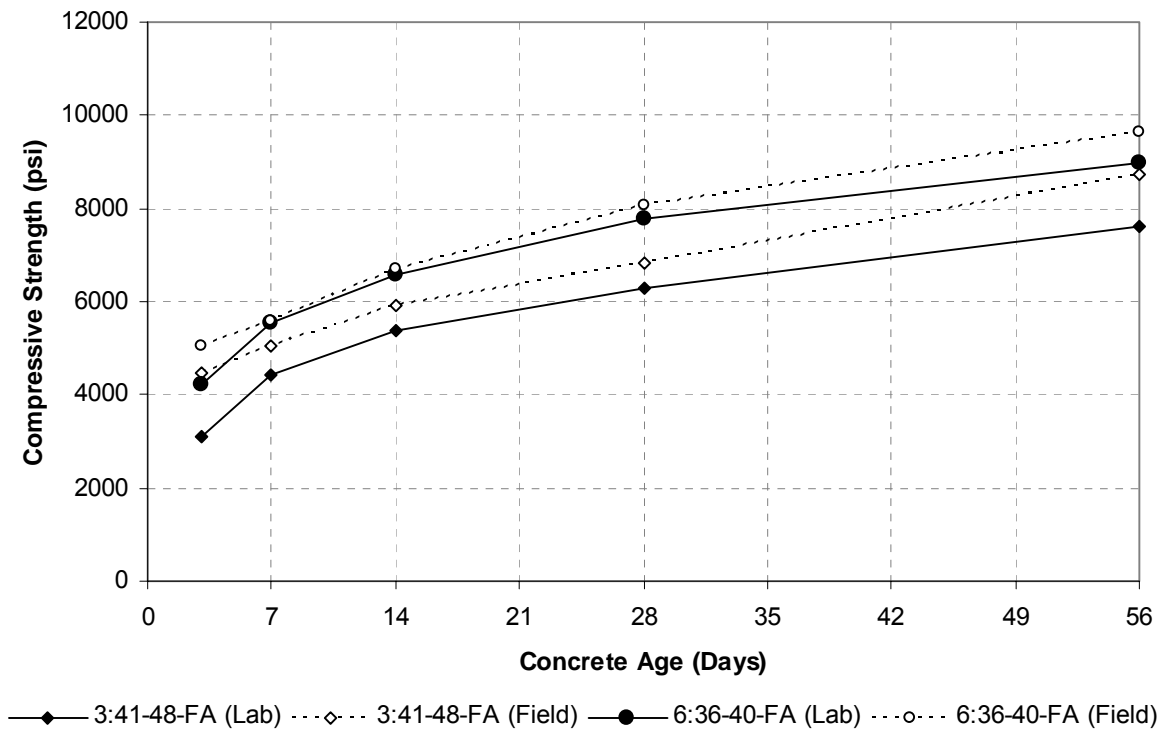


Figure 6.25 – Compressive Strength vs. Concrete Age under Laboratory and Field Conditions

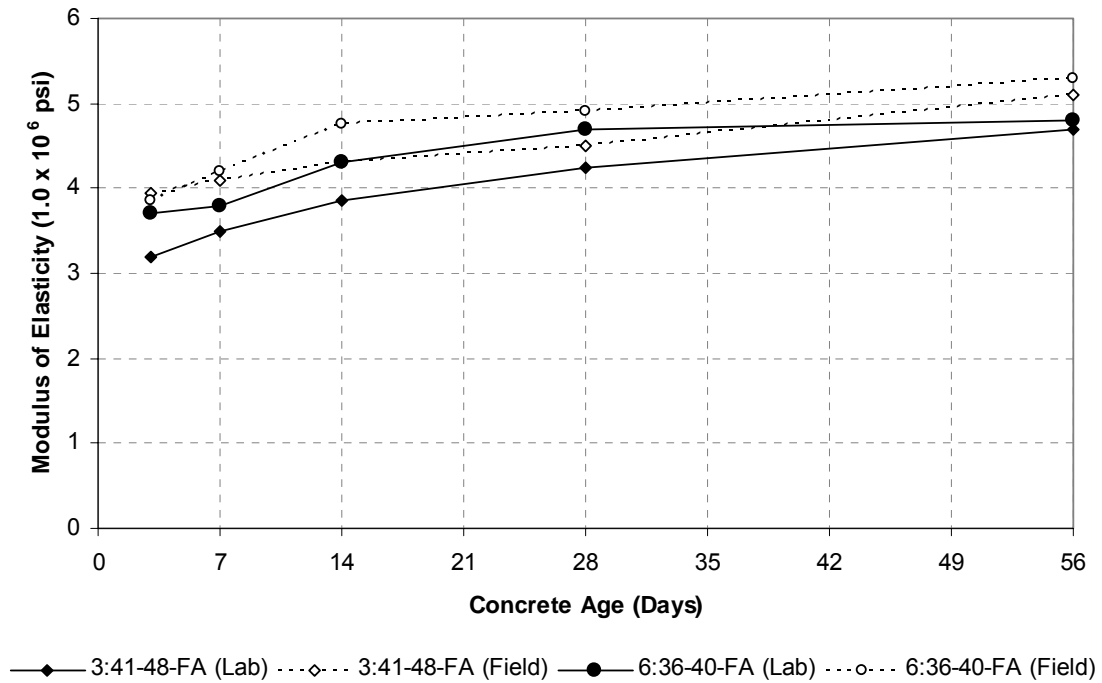


Figure 6.26 – Modulus of Elasticity vs. Concrete Age under Laboratory and Field Conditions

6.6 PHASE V - METHODS TO MODIFY THE VISCOSITY OF SCC MIXTURES

6.6.1 Fresh Concrete Properties

Phase V was formulated to clarify the effects of different methods to modify the viscosity of SCC mixtures. Among the SCC mixtures prepared with VMA as the method to modify the viscosity, the results indicate at similar slump flow values the viscosity of the SCC mixtures was not increased even at high dosage amounts of VMA. However, to some extent the results suggest that the VMA may provide a slight increase in stability at higher values of slump flow with increasing VMA dosage. This is according to the VSI ratings provided in Table 6.9 for those mixtures at higher slump flow values. At lower slump flow values the VMA appeared to have no profound effect on the stability of the SCC mixtures.

The results for the SCC mixtures prepared with high dosages of fly ash as the method to modify the viscosity reveal that an increase in fly ash percentage did not correspond to an increase in viscosity. In fact, the water slump of the SCC mixtures increased as the percentage of fly ash was increased, which resulted in a higher degree of segregation at the batch plant locations. This higher degree of segregation is not evident by the VSI ratings provided in Table 6.9 since 3 is the highest VSI rating, but it is an observational behavior made by the researcher. Neither the stability nor the viscosity of these SCC mixtures seemed to be significantly affected by the higher percentages of fly ash at lower slump values such as those that represent job site testing.

The results in Table 6.9 show that the incorporation of the silica fume provided no increase in viscosity by evidence of the T_{50} times. However, the utilization of the silica fume was found to improve the stability of the SCC mixtures as can be seen by the decreased VSI ratings. It is believed that this stability can be attributed to the reduction of the water slump and absorption of free water due to the high fineness of the silica fume. Replacement percentages of silica fume above 8% were found not to provide a considerable increase in stability at similar slump flow values nor a considerable reduction in water slump. Thus, replacement percentages above 8% would not be necessary and only result in increased cost. Furthermore, Table 4.5 indicates that the required dosage of HRWRA was increased as the replacement percentage of silica fume was increased.

The incorporation of GGBFS provided results similar to the silica fume mixtures. For example, the GGBFS provided a reduction in the water slump and showed a higher degree of stability at the batch plant compared to 6:AL-36-33 FA. In addition, the

incorporation of the GGBFS seems to slightly increase the T_{50} times compared to the silica fume and fly ash mixtures at similar slump flow values. As with the silica fume mixtures, the required dosage of HRWRA was increased with the incorporation of the GGBFS.

The amount of entrapped air for the GGBFS mixtures was increased with higher replacement percentages of GGBFS. The amount of entrapped air was 4.1% for 13:AL-36-40 SG, 10.5% for 14:AL-36-50 SG, and 17% for 15:AL-36-60 SG. These results indicate that the amount of entrapped air nearly doubled for every 10% increase in GGBFS. An experiment was conducted to determine if the Glenium 3030 NS was in fact the primary cause of this entrapped air. In this experiment, mixture 14:AL-36-50 SG was remade with exactly the same mixture proportions with the Glenium 3030 NS being replaced by PolyHeed 1025. Table 4.5 shows that the required dosage amount of PolyHeed 1025 to achieve similar slump flow values at the batch plant was 20 oz/cwt. This high dosage amount was necessary due to the fact that the PolyHeed 1025 is a mid-range water reducing admixture. The results of this experiment can be seen by examining mixture 14:AL-36-50 SG (LA) in Table 6.9, where (LA) stands for low air. The results show that when only the PolyHeed 1025 was utilized the amount of entrapped air was reduced from 10.5% to 2.6%, respectively. Based upon these results it was determined that the Glenium 3030 NS was the main reason for the increase in entrapped air.

These results in Table 6.9 show that the Micron 3 did not provide an increase in stability or viscosity compared to the fly ash mixtures even at high replacement percentages. This outcome was unexpected since the Micron 3 was considerably finer

than both the cement and the traditional fly ash. However, it is believed that this outcome is due to the fact that the Micron 3 was in replacement of the cement and not the fly ash. Since the Micron 3 is notably more spherical than the cement it provided an increase in workability. This can be seen by observing the increase in water slump for 16:AL-36-8 M3 compared to 6:AL-36-33 FA. Earlier results illustrated that as the water slump was increased the stability of the mixture was decreased, especially at higher slump flow values. The stability of the Micron 3 mixtures was reduced in spite of the fact that the Micron 3 was finer. Furthermore, the results in Table 6.9 show that the introduction of the limestone filler provided no considerable increase in stability, but exhibited a reduction in water slump for a constant dosage of HRWRA. This reduction in water slump at the batch plant is most likely due to the reduction of water content from 284 lb/yd³ for the fly ash mixtures to 270 lb/yd³ for the limestone filler mixtures as shown in Table 4.5.

Table 6.9 – Fresh Concrete Properties for Phase V (cont. on next page)

Item		Self-Consolidating Concrete Mixtures							
		1:AL-41-0 VMA	2:AL-41-2 VMA	3:AL-41-10 VMA	4:AL-41-18 VMA	5:AL-36-33 (2) FA	6:AL-36-33 FA	7:AL-36-40 FA	8:AL-36-50 FA
Plant	Slump Flow (inches)	29	31	29	29	28	32	33	32
	VSI	3	3	2.5	2	2	3	3	3
	T50 (sec.)	1.1	0.98	0.85	0.9	0.88	0.76	0.62	1.5
	Wet Slump (inches)	7	6	6	6.5	2.25	3.75	4.00	5
Job Site	Slump Flow (inches)	18.0	23.0	18.0	22.0	17.5	21.0	20.0	21
	VSI	0.0	1.0	0.0	1.0	0.0	0.5	0.0	0.5
	T50 (sec.)	>30	1.52	>30	1.4	>30	1.86	2.10	1.09
	Air Content (%)	3	3.2	4	3.4	4.4	3.4	3.0	3.7
	Temp. (°F)	72	73	76	72	79	74	74	75
	Unit Weight (lb/ft ³)	146.8	146.6	146.1	145.3	145.68	145.5	146.4	145

Table 6.9 - Fresh Concrete Properties for Phase V (cont. on next page)

Item		Self-Consolidating Concrete Mixtures							
		9:AL-36-6 SF	10:AL-36-8 SF	11:AL-36-10 SF	12:AL-36-15 SF	13:AL-36-40 SG	14:AL-36-50 SG	14:AL-36-50 SG (LA)	15:AL-36-60 SG
Plant	Slump Flow (inches)	29	29.5	29	29	26	29	28	30
	VSI	1.5	1.5	1.5	1.5	1.5	2.0	1.5	2
	T50 (sec.)	1.16	0.76	0.94	1.16	2.29	1.50	1.56	1.12
	Wet Slump (inches)	1	0.25	0.25	0	0	0.25	0.50	0.75
Job Site	Slump Flow (inches)	22.0	21.5	20.75	22.0	16.0	18.0	21.0	20
	VSI	0.0	0.0	0.5	0.5	0.0	1.0	0.5	0.5
	T50 (sec.)	1.2	1.01	1.22	1	>30	>30	2.62	2.37
	Air Content (%)	3.4	3.7	3.5	5.0	4.1	10.5	2.6	17
	Temp. (°F)	75	76	74	75	83	75	76	76
	Unit Weight (lb/ft ³)	145.6	145.2	145.68	144.2	147.8	137.4	148.0	136.92

Table 6.9 – Fresh Concrete Properties for Phase V (cont.)

Item		Self-Consolidating Concrete Mixtures					
		16:AL-36-8 M3	17:AL-36-12 M3	18:AL-36-16 M3	19:AL-36-8 LS	20:AL-36-15 LS	21:AL-36-20 LS
Plant	Slump Flow (inches)	32	34	31	27.5	27	28
	VSI	3	3	3	2	2	2.5
	T50 (sec.)	1.15	0.72	0.9	1.44	1.69	1.56
	Wet Slump (inches)	6	7	6	2	2.5	3.25
Job Site	Slump Flow (inches)	22.0	24.0	22.0	17.5	19.5	21.0
	VSI	1.0	1.5	1.0	0.5	0.5	0.5
	T50 (sec.)	1.06	0.75	1.09	>30	>30	1.16
	Air Content (%)	2.9	2.6	2.8	4.5	5	3.7
	Temp. (°F)	76	77	78	77	76	77
	Unit Weight (lb/ft ³)	147.16	145.68	147.4	144.8	144.2	145.6

6.6.2 Hardened Concrete Properties

Compressive Strength: The hardened concrete properties determined for Phase V can be seen by looking at Figures 6.27 through 6.38. Each SCC mixture was compared to a base line mixture in order to determine the effect of each method to modify the viscosity on the hardened concrete properties. SCC mixture 1:AL-41-0 VMA was determined to be the appropriate base line mixture for all SCC mixtures prepared at a water-to-cementitious materials ratio of 0.41, while 6:AL-36-33 FA will be used as the base line mixture for all SCC mixtures prepared at a water-to-cementitious materials ratio of 0.36.

Figure 6.27 indicates that the base line mixture with no VMA showed higher values of compressive strength at all ages, while the SCC mixture 2:AL-41-2 VMA and 3:AL-41-10 VMA produced the lowest compressive strength results. However, this is most likely due to the influence of other external factors rather than the incorporation of the VMA. The compressive strengths for these mixtures ranged from 6,800 to 7,500 psi at 56-days.

By comparing the SCC mixtures 1:AL-41-0 VMA and 2:AL-41-2 VMA to 5:AL-36-33 (2) FA and 6:AL-36-33 FA in Figure 6.29 it can be seen that the reduction in water-to-cementitious materials ratio from 0.41 to 0.36 increased the compressive strengths, on average, 2,300 psi at 56-days. This is expected since it is a well known fact that the strength is increased as the water-to-cementitious materials ratio decreases. Furthermore, the results indicate that compressive strength decreased as the percentage of fly ash increased. This is primarily due to the fact there is only enough calcium hydroxide in the paste in which the Class F fly ash can react to form calcium silicates. Therefore, higher replacement percentages of fly ash may result in unreacted ash that

may cause a reduction in the compressive strength. Additionally, Figure 6.29 shows that replacement percentages of fly ash above 50% should not be utilized due to the fact the critical 28-day compressive strength of 5,200 psi would not be achieved.

The results obtained from the compressive strength tests for both the silica fume and GGBFS mixtures can be seen in Figures 6.31 and 6.33. Unlike Phase IV where the incorporation of the silica fume produced a clear increase in compressive strength, the incorporation of the silica fume for these materials did not indicate a significant increase in compressive strength at 56-days. This was unexpected since silica fume is known to typically improve the microstructure and increase compressive strengths. Furthermore, Figure 6.31 reveals that the SCC mixture with 15% replacement of silica fume showed a decrease in compressive strength compared to the base line mixture. This decrease in compressive strength can be possibly attributed to the fact that the SCC mixture contained a higher percentage of entrapped air compared to the base line mixture.

As discussed in Section 6.6.1, unusually high amounts of entrapped air of 10.5% and 17% were obtained at replacement percentages of 50% and 60% GGBFS, respectively. It was determined that as the porosity increased the compressive strength was decreased as shown in Figure 6.33. For example, mixtures 14:AL-36- 50 SG and 14:AL-36-50 SG (LA) was comprised of exactly the same mixture proportions with the exception of the water reducing admixture. According to Figure 6.33, the reduction in entrapped air from 10.5% to 2.6% corresponded to an increase of compressive strength of at least 4,800 psi at 28 and 56-day. This is a remarkable increase in compressive strength, and it shows the significance of the porosity-compressive strength relationship. By examining mixtures 13:AL-36-40 SG and 14:AL-36-50 SG (LA) it appears that as the

replacement of GGBFS increased from 40% to 50%, the compressive strength was increased by 1,400 psi and 1,800 psi at 28 and 56-days, respectively. This is considering the fact that both mixtures contained reasonably low air contents. Moreover, the utilization of GGBFS was found to increase the compressive strength compared to the base line mixture of no less than 1,300 psi at 56-days.

Figure 6.35 indicates that the use of Micron 3 produced a decrease in compressive strengths compared to the base line mixture. The SCC mixtures with Micron 3 demonstrated an average compressive strength loss of 1,000 psi at 28 and 56-days. However, it is thought that this decrease in compressive strength is not a result of the Micron 3, but is due to the fact that the Micron 3 was in replacement of cement instead of fly ash. As the replacement percentage of Micron 3 was increased the total percentage of fly ash within the SCC mixture increased accordingly. As higher replacement percentages of Micron 3 was introduced into the SCC mixtures, it is probable that the amount of unreacted fly ash was increased resulting in a decrease in compressive strength. This is analogous to the high fly ash mixtures shown in Figure 6.29. However, all Micron 3 mixtures were well above the required critical 28-day compressive strength of 5,200 psi despite the reduced compressive strength.

Figure 6.37 shows that the introduction of the limestone filler caused a reduction in compressive strength compared to the base line mixture. Figure 6.37 further reveals that the compressive strength of the SCC mixtures is lower as the percentage of limestone filler increases. The reduction in compressive strength is a direct result of the limestone filler being inert. The replacement of cementitious materials by limestone filler is in

effect raising the water-to-cementitious materials ratio resulting in lower compressive strengths.

Modulus of Elasticity: Figures 6.28, 6.30, 6.32, 6.34, 6.36, and 6.38 present the calculated modulus of elasticity values obtained for all SCC mixtures for Phase V. The development for the modulus of elasticity is similar to the strength development provided in Figures 6.27, 6.29, 6.31, 6.33, 6.35, and 6.37. Furthermore, Figures 6.27 through 6.38 indicate that higher modulus of elasticity values were achieved for higher values of compressive strengths. In order to determine if the calculated elastic modulus for the concrete mixtures is of typical sound concrete; the calculated modulus of elasticity in this phase of the research was compared with the ACI 318 (2002) Building Code ($E_c (psi) = 33 * W_c^{1.5} \sqrt{f'_c}$) and the ACI Committee 363 (2002) “State-of-the-Art Report on High-Strength Concrete” ($E_c (psi) = 40,000\sqrt{f'_c} + 1,000,000$) models. Figure 6.39 reveals that the ACI 318 (2002) overestimated the modulus of elasticity for both the ODSC and SCC mixtures. Furthermore, the ACI 318 (2002) was found to increasingly overestimate the modulus of elasticity as the compressive strength increased. This finding coincides with ACI Committee 363 (2002) that found that the equation used by the ACI 318 (2002) was only valid for compressive strengths up to 6,000 psi. On the other hand, the ACI Committee 363 (2002) equation provided an improved and typically conservative estimate for the modulus of elasticity for both the ODSC and SCC mixtures as shown in Figure 6.40. It is believed that the improved and conservative estimation for the modulus of elasticity lies in the fact that the equation provided by the ACI Committee 363 (2002) is valid for compressive strengths from 3,000 to 12,000 psi.

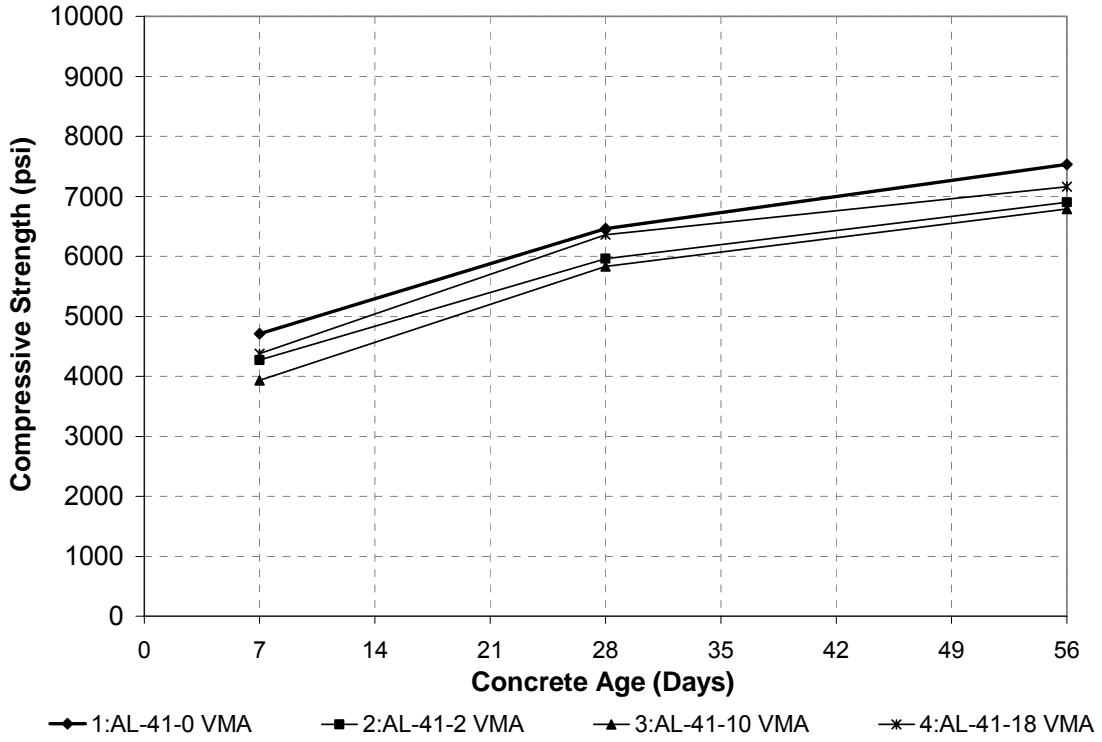


Figure 6.27 – Compressive Strength vs. Concrete Age for VMA Mixtures

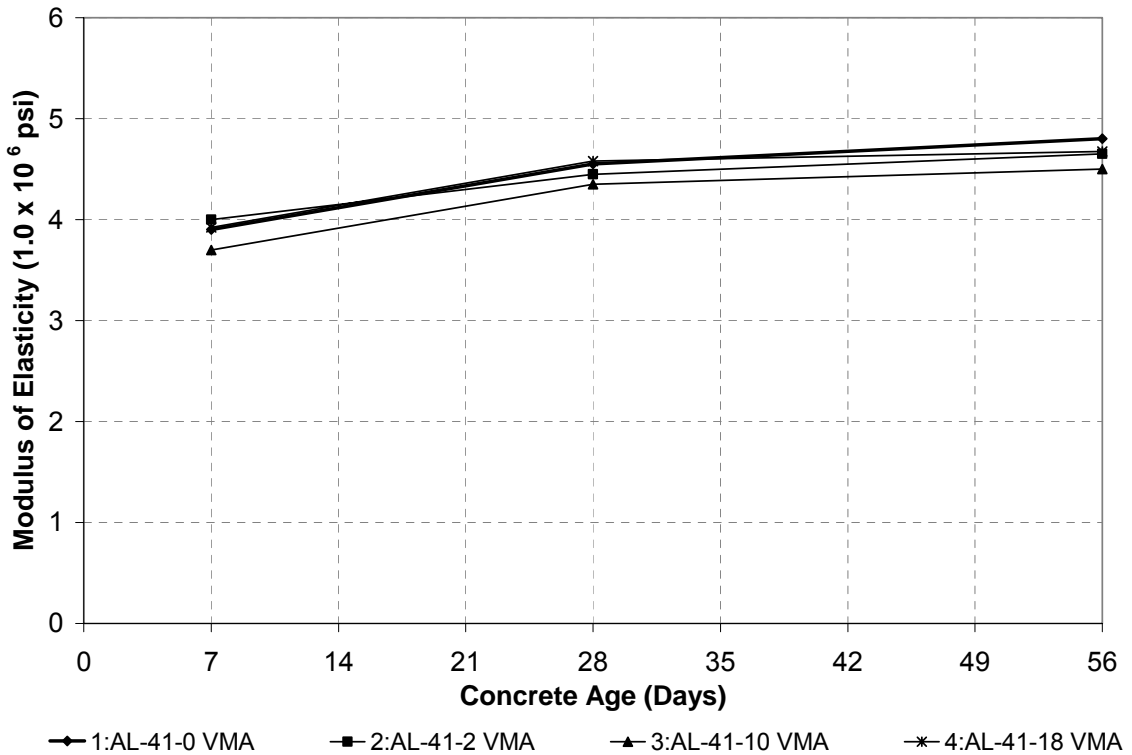


Figure 6.28 – Modulus of Elasticity vs. Concrete Age for VMA Mixtures

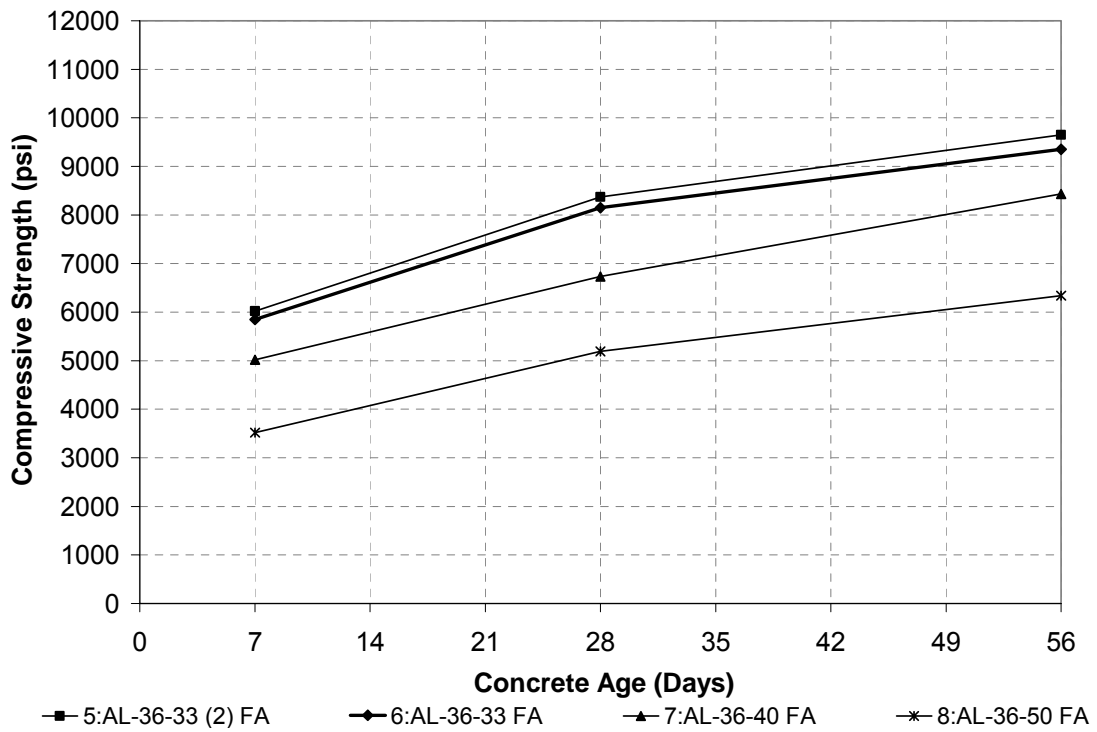


Figure 6.29 – Compressive Strength vs. Concrete Age for Fly Ash Mixtures

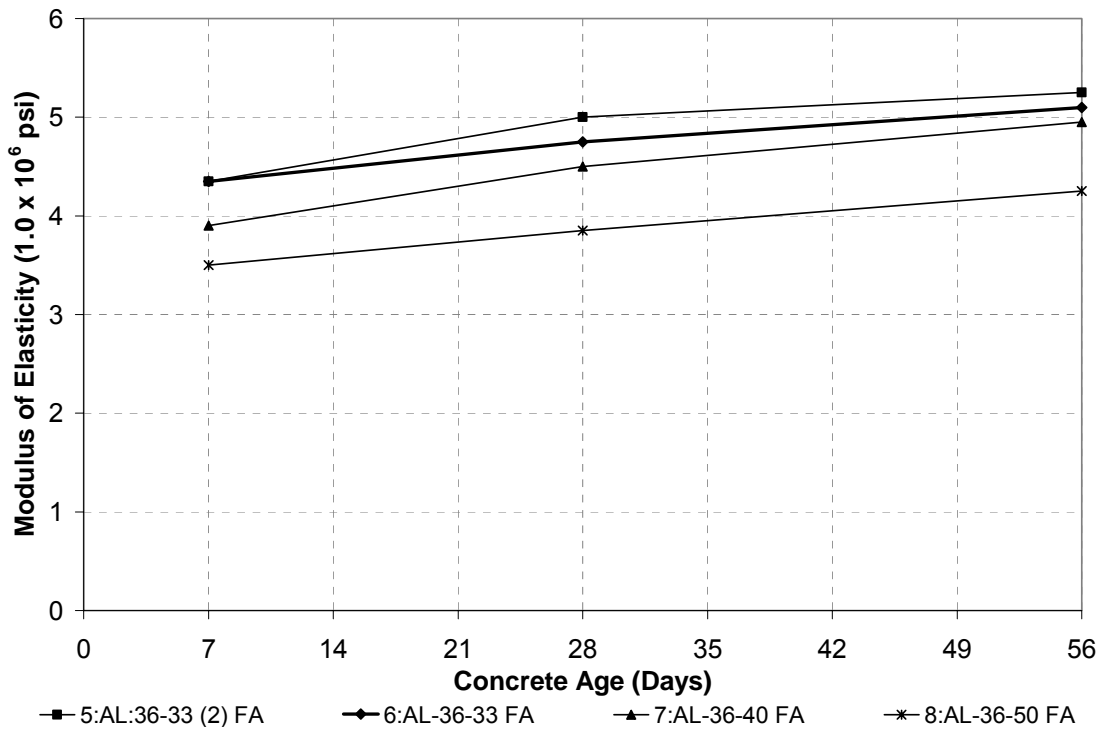


Figure 6.30 – Modulus of Elasticity vs. Concrete Age for Fly Ash Mixtures

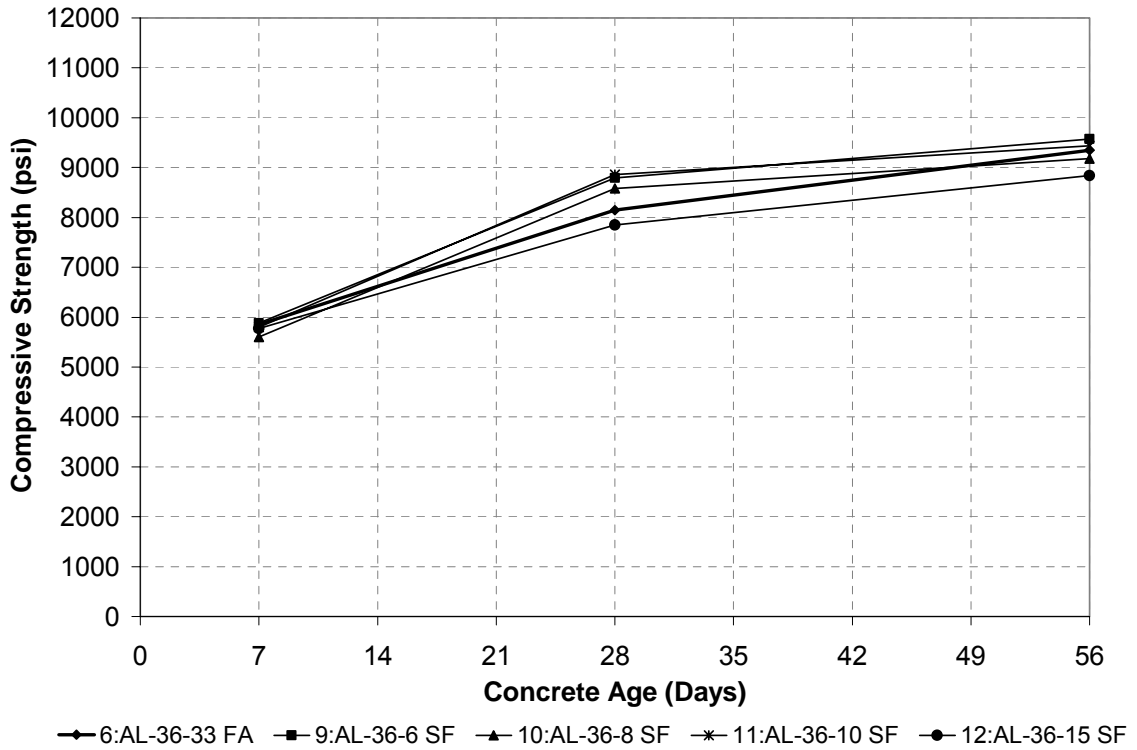


Figure 6.31 – Compressive Strength vs. Concrete Age for Silica Fume Mixtures

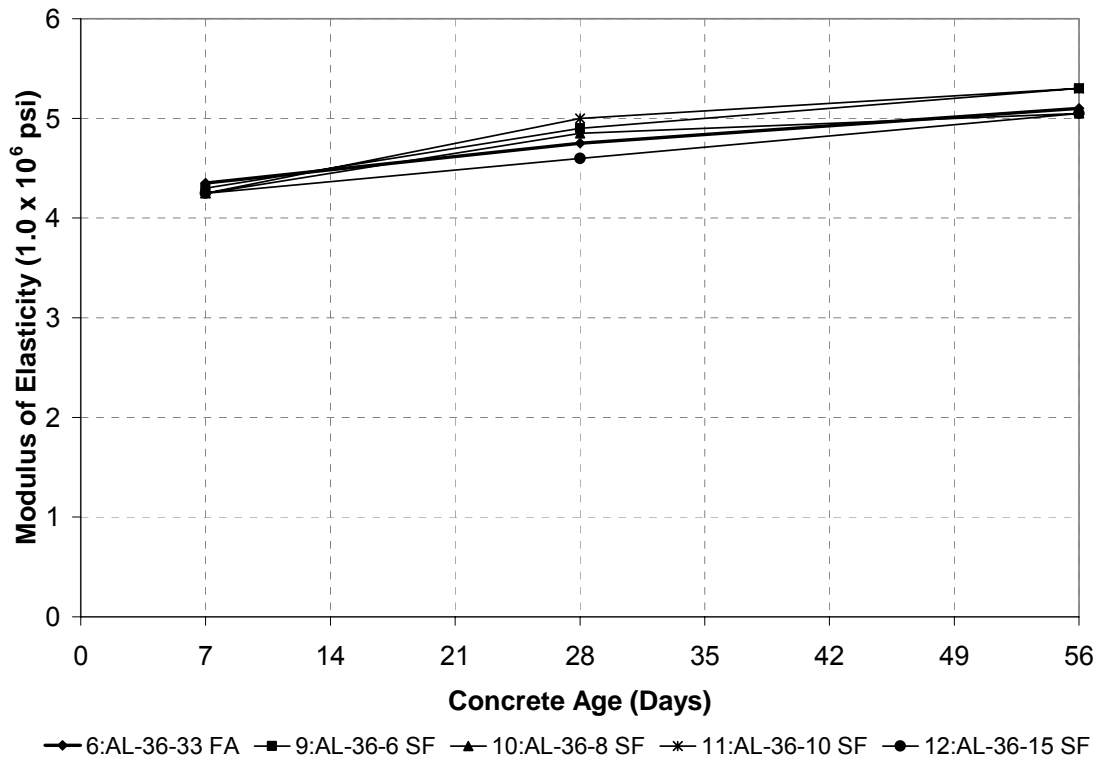


Figure 6.32 – Modulus of Elasticity vs. Concrete Age for Silica Fume Mixtures

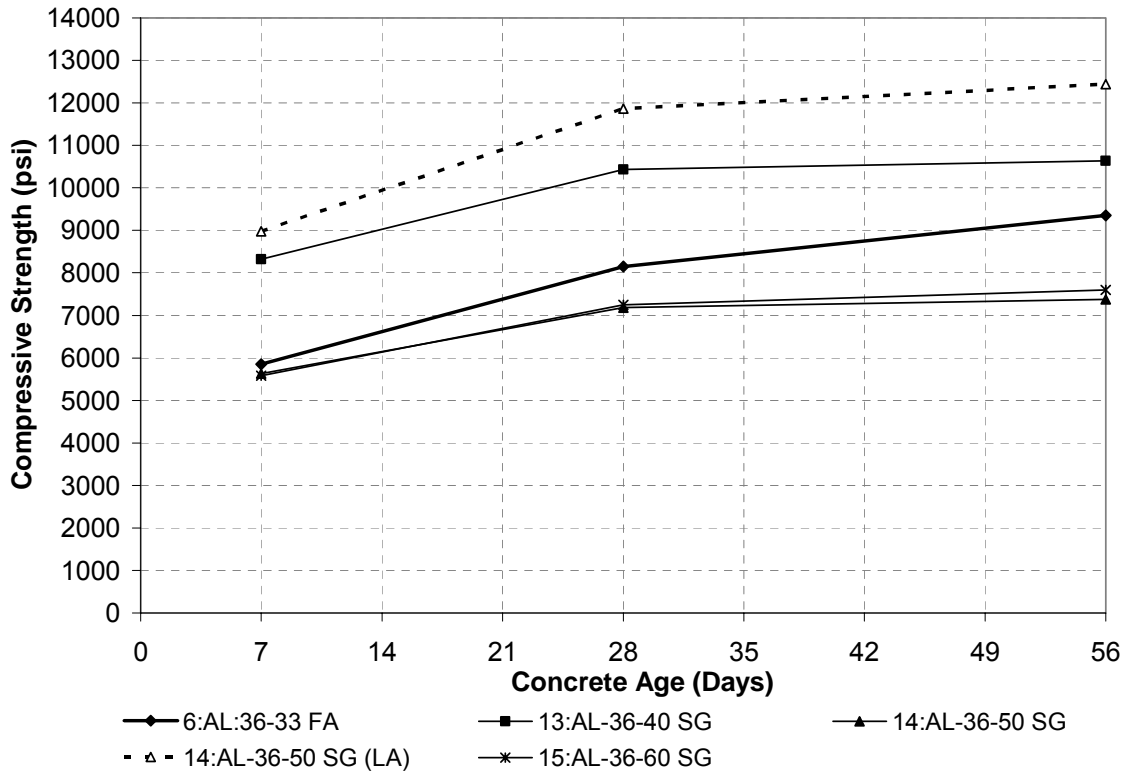


Figure 6.33 – Compressive Strength vs. Concrete Age for GGBFS Mixtures

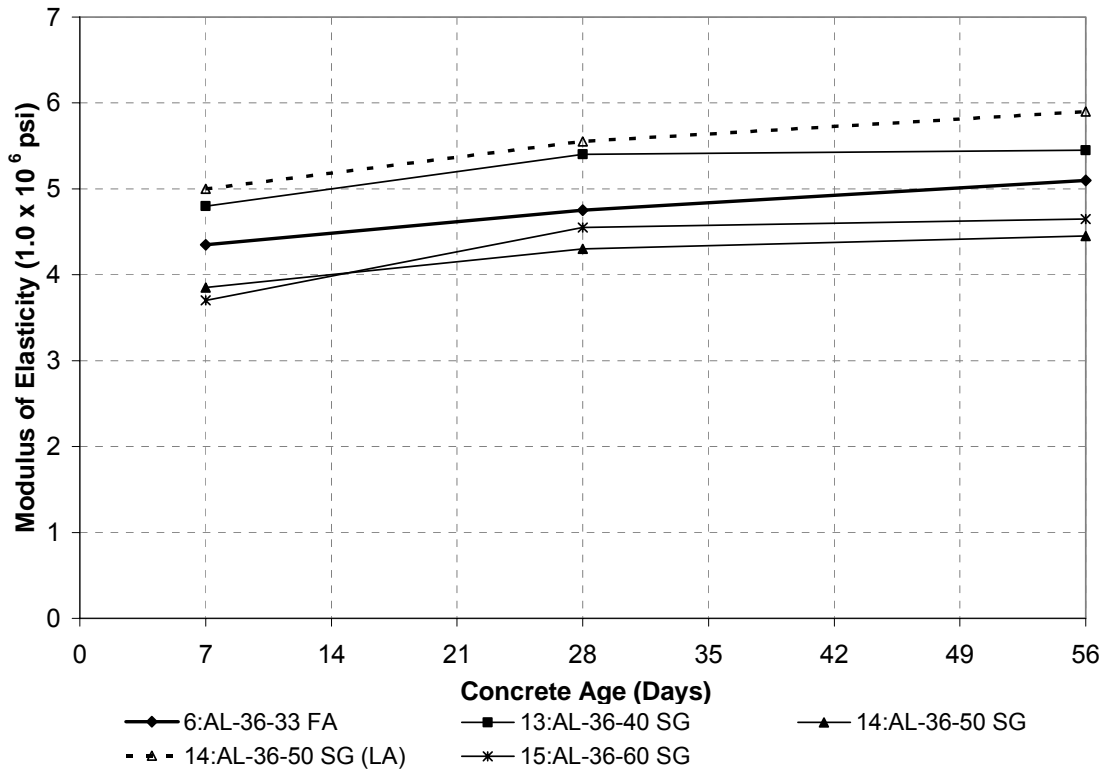


Figure 6.34 – Modulus of Elasticity vs. Concrete Age for GGBFS Mixtures

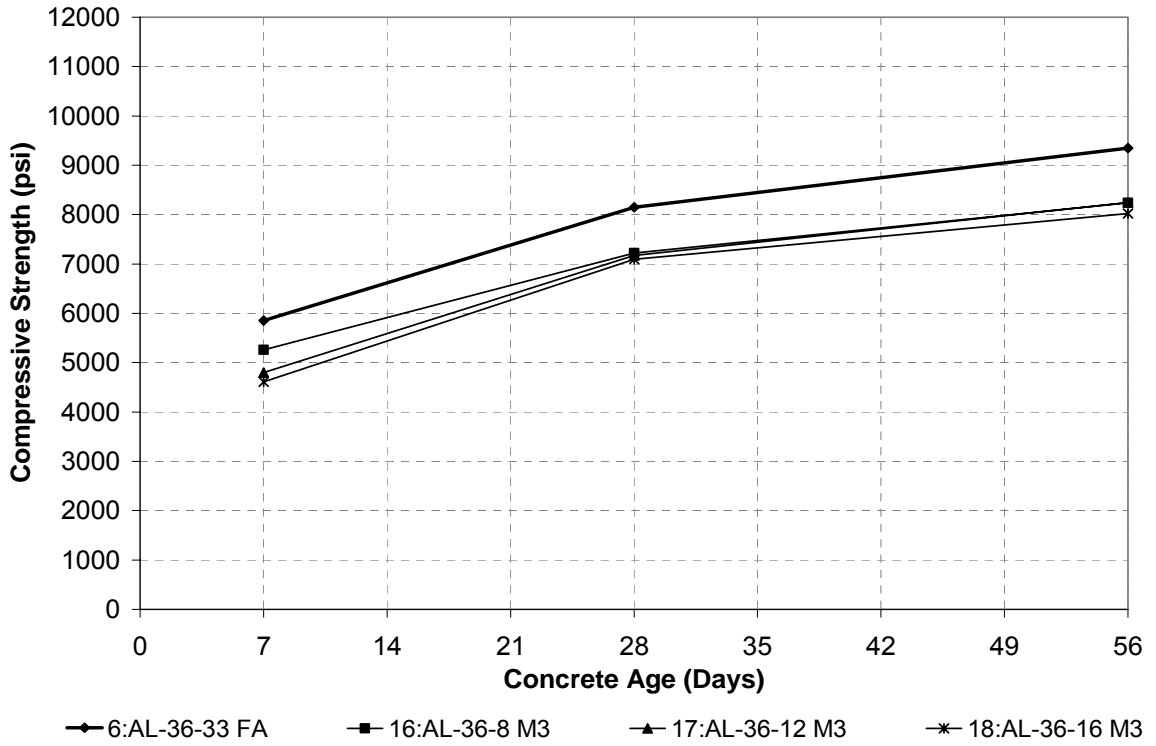


Figure 6.35 - Compressive Strength vs. Concrete Age for Micron 3 Mixtures

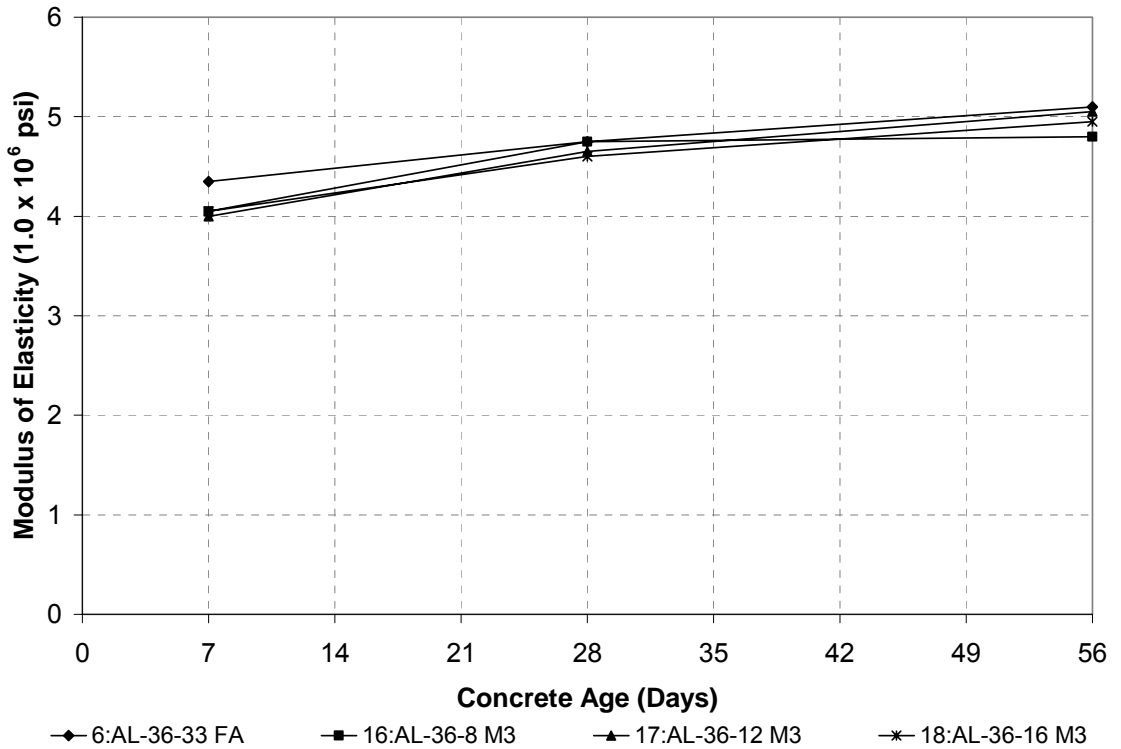


Figure 6.36 - Modulus of Elasticity vs. Concrete Age for Micron 3 Mixtures

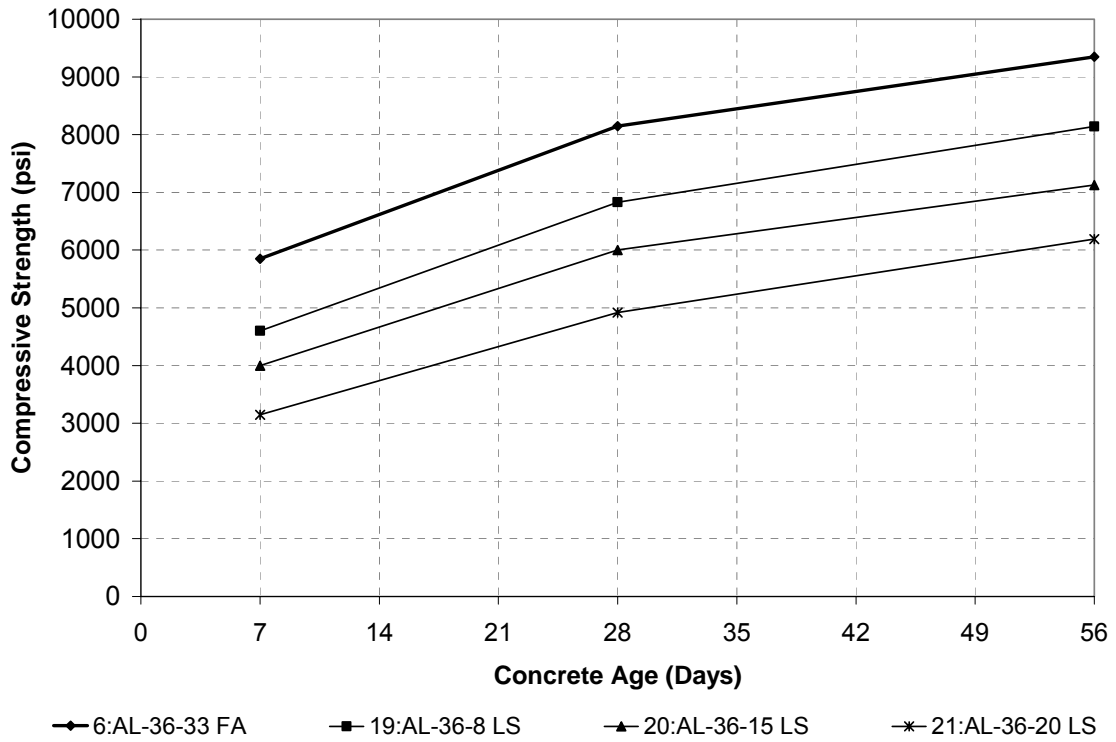


Figure 6.37 – Compressive Strength vs. Concrete Age for Limestone Mixtures

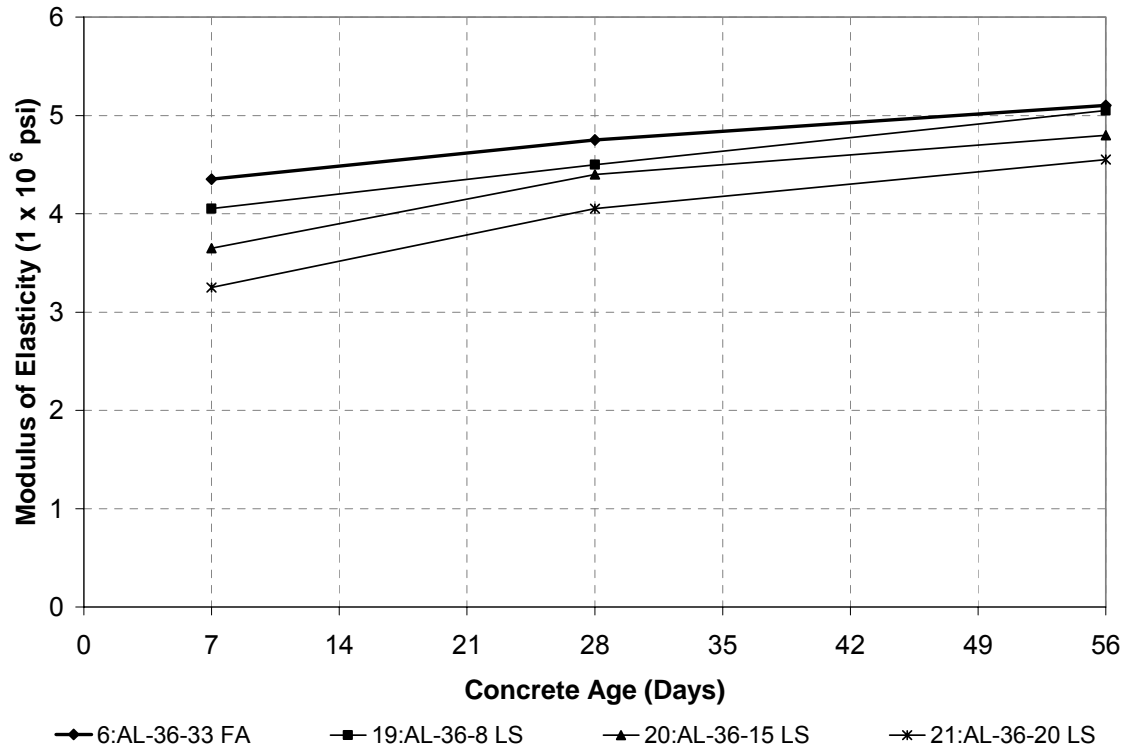


Figure 6.38 – Modulus of Elasticity vs. Concrete Age for Limestone Mixtures

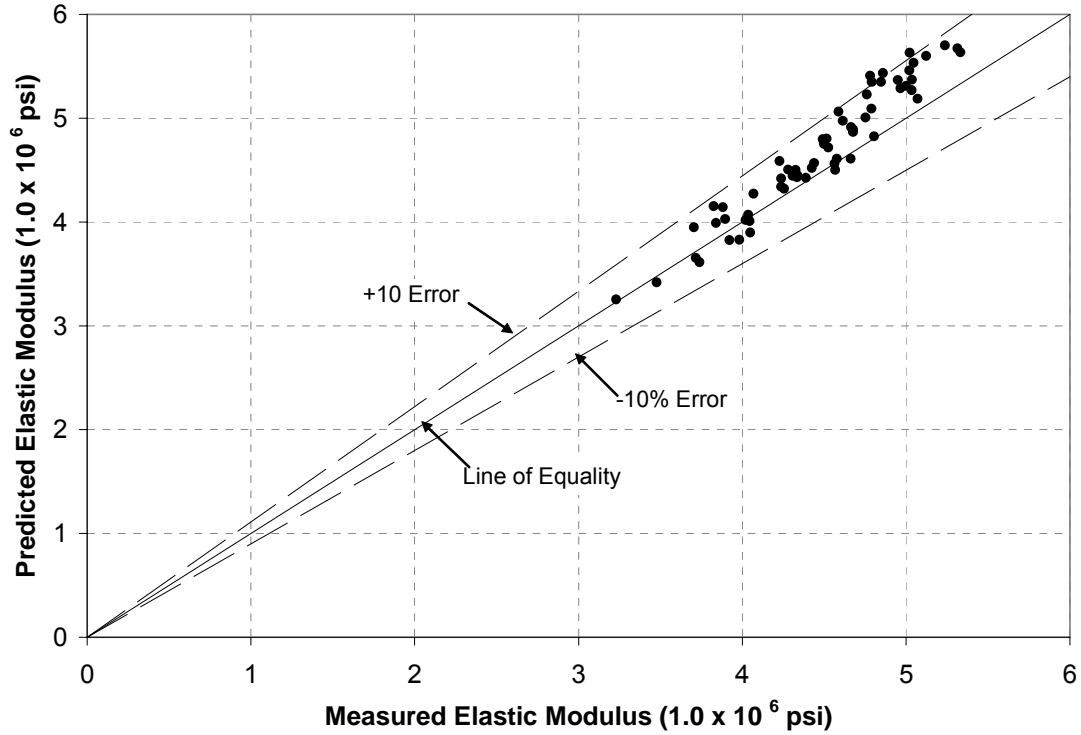


Figure 6.39 – Predicted vs. Measured Elastic Modulus According to ACI 318 (2002) Equation for Phase V

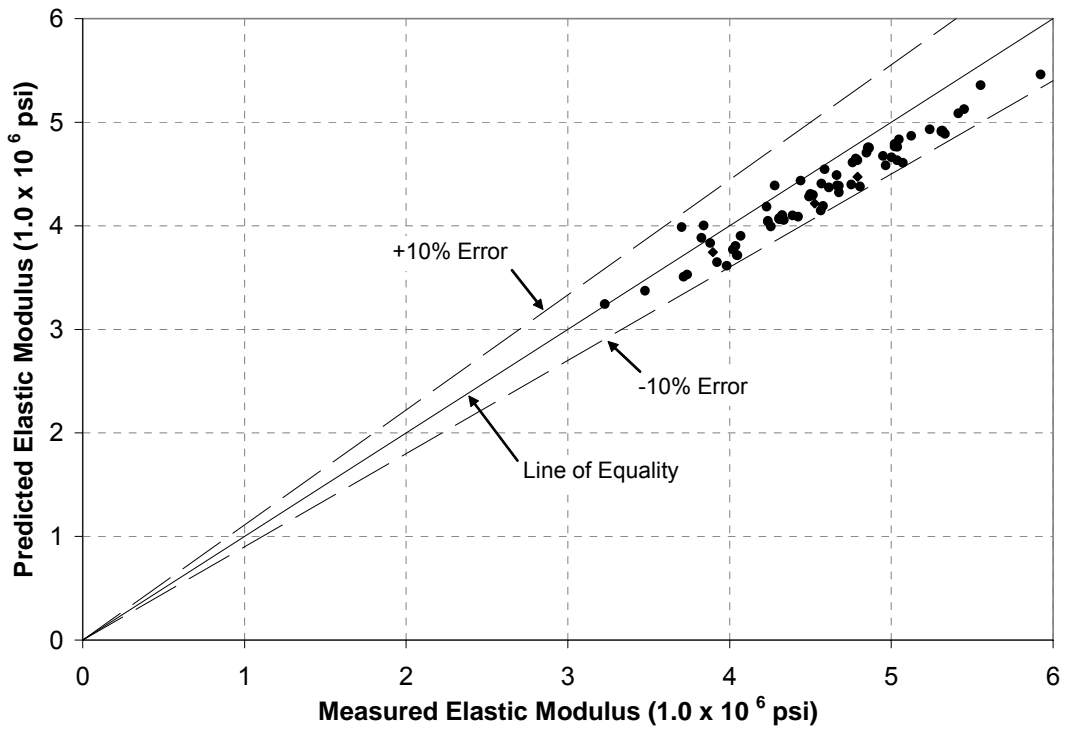


Figure 6.40 – Predicted vs. Measured Elastic Modulus According to ACI 363 (2002) Equation for Phase V

6.6.3 Effect of VMA on Fresh Concrete Properties

The results in Table 6.9 indicate that the polyethylene glycol VMA was found not to significantly influence the viscosity of the SCC mixtures even at high dosage amounts. However, results may suggest that the incorporation of the polyethylene glycol VMA provided a slight increase in stability compared to the SCC mixtures with similar mixture proportions without VMA at higher values of slump flow. Furthermore, this VMA could possibly be used to overcome deficiencies in mixture constituents in everyday batch plant operations. To study the effects of this viscosity agent on the stability of SCC mixtures when subjected to inaccurate moisture corrections, mixing water was added to or deducted from a base line mixture. This base line mixture was 5:AL-36-33 2'FA with the following modifications. The first modification is the incorporation of the VMA. Each testing point consisted of one mixture that incorporated the 2 oz/cwt of VMA and one mixture without the VMA. Secondly, the HRWR admixture dosage was reduced from 10 oz/cwt to 8 oz/cwt for all concrete mixtures. The results in Table 6.10 and Figure 6.41 indicate that at the water content equal to the base line mixture the VMA appears to have minimal effect on the slump flow, stability, or viscosity. However, as additional water was added to the base line mixture, the stability of the mixture was found to be increased with the addition of VMA. The increase in stability can be attributed to the lower slump flow values for the SCC mixtures with VMA at +10 and +20 lb/yd³. This decrease in slump flow values for the SCC mixtures that incorporated VMA is most likely due to the fact the VMA is rendering the mixture more robust as excess water is released by the HRWRA. At lower slump flow values and lower free water contents the VMA was found to be ineffective in increasing the stability of the SCC mixtures. The results from

the study indicate that the use of this type of VMA can decrease the sensitivity of the SCC mixtures due to inaccurate moisture corrections. However, at lower slump flow values the use of the polyethylene glycol VMA may not provide an increase in stability. When low water-to-cementitious materials ratios are used and the SCC mixtures are placed at lower slump flow values, the incorporation of this type of VMA may not be necessary. On the other hand, if moisture variability can not be properly controlled and the SCC mixtures are placed at higher slump flow values the use of a VMA can be beneficial.

Table 6.10 – Tabulated Results of the Effect of VMA on Fresh Concrete Properties

	Fresh Properties				Slump Flow		
	Wet Slump (inches)	Unit Weight (lb/yd ³)	Air Content (%)	Temp. (°F)	Diameter (inches)	T50 (sec)	VSI
+20 lb/yd³ without VMA	9	147.9	2.7	75	31	0.44	3
+20 lb/yd³ with VMA	8	146.8	4	75	28	0.9	2
+10 lb/yd³ without VMA	5	143.64	5	76	27.5	0.96	2.5
+10 lb/yd³ with VMA	5	142.2	3.5	74	26	1.38	2
+0 lb/yd³ without VMA	2 1/2	144.6	5.1	75	25.25	1.56	1.5
+0 lb/yd³ with VMA	2	145.4	3.9	75	25	1.69	1
-10 lb/yd³ without VMA	1 1/4	145.5	3.9	73	24.5	1.47	1
-10 lb/yd³ with VMA	1/4	144.9	4.2	74	23	2.35	1
-20 lb/yd³ without VMA	0	143.7	5	74	21.5	4.75	0
-20 lb/yd³ with VMA	0	145	4	76	20.5	3.97	0

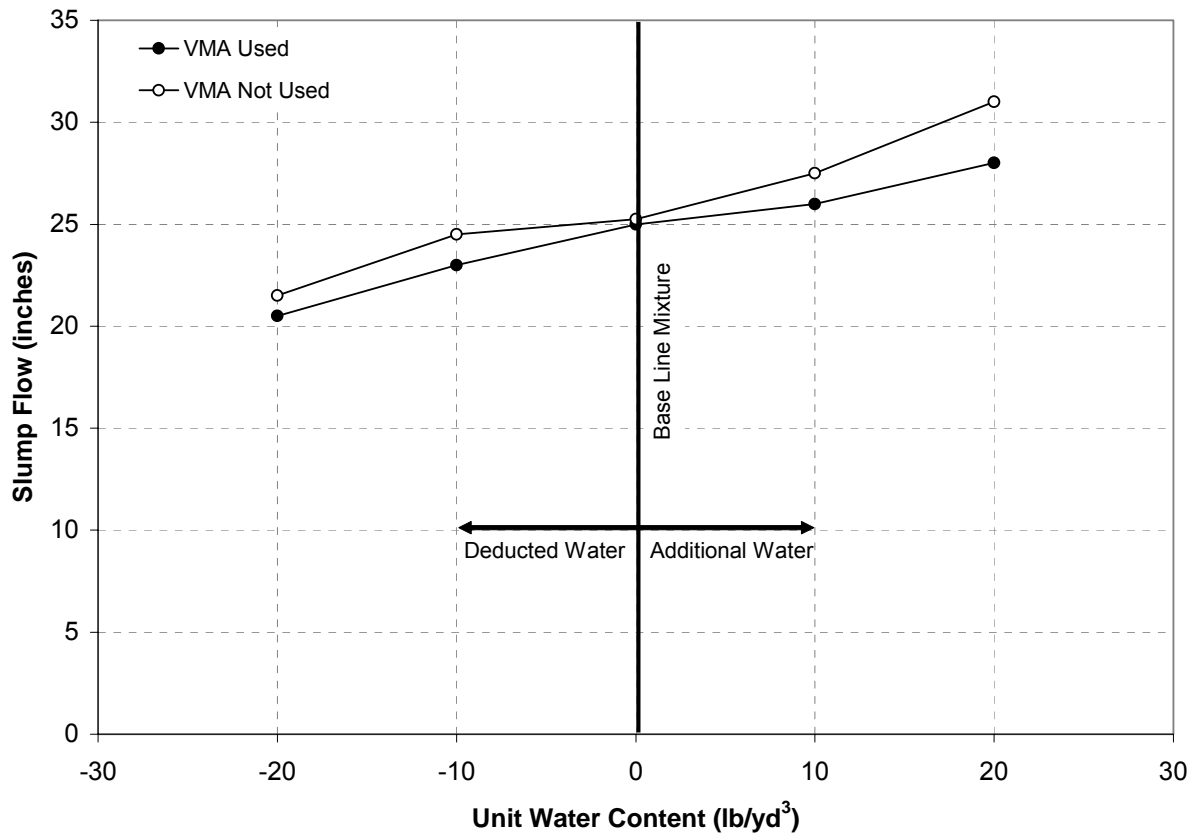


Figure 6.41 – Graphical Results of the Effect of VMA on Fresh Concrete Properties

6.7 SUMMARY OF RESEARCH FINDINGS

- Based on the results of this research, it is concluded that the early or delayed addition of the HRWRA has no considerable effect on the workability characteristics of the SCC mixtures.
- It was determined that obtaining a water slump before the addition of the HRWRA was suitable for not only ensuring correct moisture corrections, but also in determining appropriate mixture proportions for the SCC mixtures.
- It was found that obtaining a water slump under real field conditions required a considerable increase in time compared to laboratory conditions.

- The ODSC mixtures prepared for this research were found to be within the specified range of slump values at placement in addition to demonstrating typical workability characteristics for wet-hole construction.
- The incorporation of the 4 oz/cwt mid-range water reducing admixture PolyHeed 1025 seems to help maintain the workability of the SCC mixtures better than those that contained only Glenium 3030 NS.
- The ODSC mixtures demonstrated a higher degree of bleeding compared to the SCC mixtures prepared at the same water-to-cementitious materials ratio.
- It was concluded that the HRWRA Glenium 3030 NS was the primary cause of the increased air content for the SCC mixtures.
- The results from this research indicate that at similar slump flow values the viscosity of the SCC mixtures was not increased at high dosage amounts of VMA. However, the results suggest that the VMA may provide a slight increase in stability at higher values of slump flow with increasing VMA dosage.
- At lower slump flow values such as those representing the job site testing; the VMA appears to have no effect on the stability of the SCC mixtures.
- The results show that the use of VMA could possibly be used to overcome deficiencies in mixture constituents in everyday batch plant operations, which mainly consist of inaccurate moisture corrections.
- Based on the materials and mixtures proportions used for Phase V, the incorporation of high amounts of fly ash, Micron 3, or limestone filler as the method to modify the viscosity was found not to increase the viscosity of the SCC mixtures by evidence of the T_{50} times.

- The incorporation of the silica fume provided no increase in viscosity by evidence of the T_{50} times. However, the utilization of the silica fume was found to improve the stability of the mixtures.
- The incorporation of GGBFS provided a reduction in the water slump and showed a higher degree of stability at the batch plant compared to mixtures prepared with fly ash and at the same water-to-cementitious materials ratio. In addition, the incorporation of the GGBFS seems to slightly increase the T_{50} times compared to the silica fume mixtures and the fly ash mixtures at similar slump flow values.
- The SCC mixtures prepared at a water-to-cementitious materials ratio of 0.41 demonstrated slightly lower compressive strengths compared to those of the ODSC mixtures. It is concluded that this is a result of the higher replacement percentage of cement by fly ash for those mixtures.
- At a constant water-to-cementitious materials ratio the use of the silica fume or ground granulated blast furnace slag (GGBFS) can provide an increase the compressive strength.
- High replacement percentages of fly ash may result in unreacted ash that may cause a reduction in the compressive strength.
- The introduction of the limestone filler caused a reduction in compressive strength compared to the base line mixture. The primary reason for the reduction in compressive strength is a direct result of the limestone filler being inert. The replacement of cementitious materials by limestone filler is in effect raising the water-to-cementitious materials ratio resulting in lower compressive strengths.

- The SCC mixtures prepared at the same water-to-cementitious materials ratio as the ODSC mixtures demonstrated a reduction in RCPT values at 91 and 365-days.
- The RCPT values obtained at 91-days for the SCC and ODSC mixtures were found to decrease with time. This is because as the hydration process proceeds, the interconnected pores that were present at 91-days are being filled by the continuous and overall increase in volume due to the formation of C-S-H and the continuous growth of the calcium hydroxide within the capillaries pores, which lowered the RCPT values at 365-days.
- The introduction of ground granulated blast furnace slag (GGBFS) was found to increase the RCPT values compared to the (FA) SCC mixtures.

CHAPTER 7

PROPOSED EXPERIMENTAL FIELD STUDY

7.1 INTRODUCTION

The primary purpose of the field study is to evaluate the use of SCC as a viable material to be used in drilled shaft construction. This field study will provide a means of comparison between self-consolidating concrete and ordinary drilled shaft concrete for both fresh and hardened properties under simulated field conditions. A brief discussion of the proposed field study is shown below. This discussion includes test shafts, fresh concrete property testing, hardened concrete property testing, placement monitoring, testing of non-exhumed shafts, testing of exhumed shafts, and instrumentation. The proposed site for this field study is located approximately 1.25 miles southeast of Nichols, South Carolina as shown in Figure 7.1. Unfortunately, due to long construction delays and design set backs the researcher will have very limited involvement in the field study. As a result, changes to this proposed field study below will almost certainly occur without the researcher's knowledge. It is recommended that the actual construction details and concrete testing that occurred for this field study be obtained from the research advisors. Furthermore, all testing procedures listed in this chapter should be conducted using current ASTM standards.

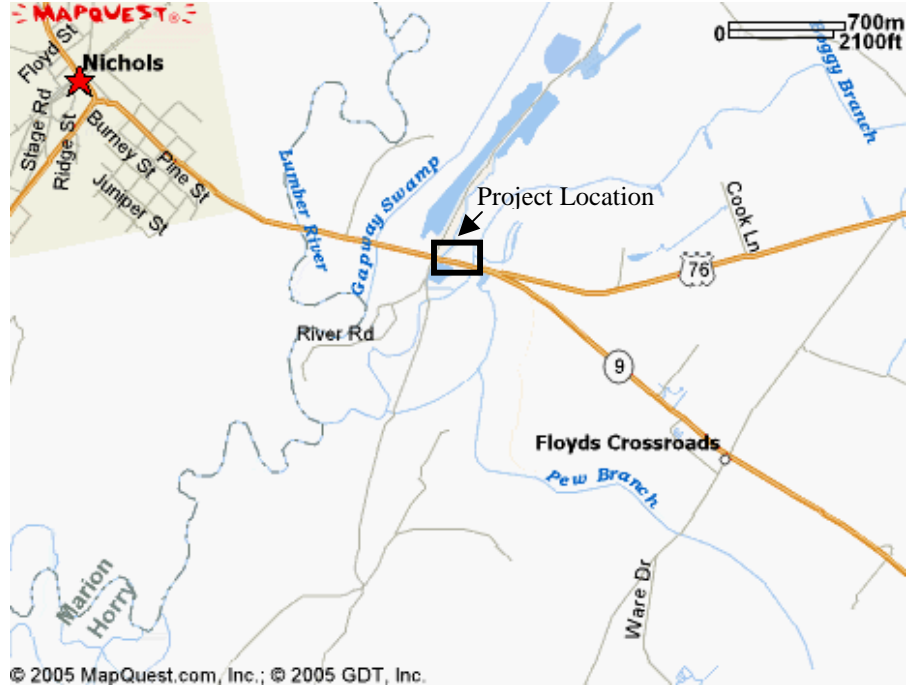


Figure 7.1 – Proposed Field Site (courtesy of Mapquest 2005)

7.2 TEST SHAFTS

- Day 1 Experimental Casting: 2 - 6.0 Ø X 30 ft test shafts made with ordinary drilled shaft concrete. One test shaft consisting of ordinary drilled shaft concrete shall be exhumed at 28 days or later after placement for visual inspection and testing.
- Day 2 Experimental Casting: 2 - 6.0 Ø X 30 ft test shafts made with self-consolidating concrete (SCC). One test shaft consisting of SCC shall be exhumed at 28 days or later after placement for visual inspection and testing.

7.3 FRESH CONCRETE PROPERTY TESTING

- Slump Test ASTM C 143 (1998)
 - Performed on all ordinary drilled shaft concrete mixtures directly after mixing and time of placement.

- The slump of the ordinary drilled shaft concrete mixtures, at the time of placement, shall be 8 ± 1 inches.
- Performed periodically on all ordinary drill shaft concrete mixtures for a duration of no less than 5 hours after batching (slump retention).
- Slump Flow Test
 - Performed on SCC mixtures directly after mixing and time of placement.
 - The slump flow of the SCC mixtures, at the time of placement, shall be 21 ± 3 inches.
 - Performed periodically on all self-consolidating concrete mixtures for a duration of no less than 5 hours after batching (slump flow retention).
- Total Air Content and Unit Weight ASTM C 138 (1998)
- J-Ring Test
- Segregation Column
- Bleeding Test ASTM C 232 (1998)
- Setting by Penetration Resistance ASTM C 403 (1998)
 - 6 Ø x 6 inch cylindrical specimens of mortar shall be obtained by wet sieving.

7.4 HARDENED CONCRETE PROPERTY TESTING

- Compressive strength, (f_c): ASTM C 39 (1998) and Elastic Modulus, (E_c): ASTM C 469 (1998)
 - 3 – 6 Ø x 12 inch molded specimens shall be cast per testing age.
 - The curing of the specimens shall be done in accordance with ASTM C 31 (1998).
 - The specimens are to be demolded no earlier than 2 x initial set.
 - The specimens should be tested at ages of 3, 7, 14, 28, and 56 days.
- Drying Shrinkage: ASTM C 157 (1998)
 - 3 – 3 x 3 x 12 inch molded specimens shall be cast per mixture.
 - The shrinkage bars shall be placed in a lime saturated bath for the first 28 days. Afterwards, the specimens shall be removed from the lime bath and placed in air storage.

- The specimens are to be demolded no earlier than 2 x initial set.
- The specimens should be tested at 1, 2, 3, 7, 14, 28, 56, 91, 180, and 365 days after removal from lime saturated bath.
- Permeability: ASTM C 1202 (1998)
 - 3- 4 Ø x 8 inch molded specimens shall be cast per testing age.
 - The specimens are to be demolded no earlier than 2 x initial set.
 - The curing of the specimens shall be done in accordance with ASTM C 31 (1998).
 - The specimens should be tested at ages of 91 and 365 days.

7.5 PLACEMENT MONITORING

- The elevation difference between the inside and outside of the rebar cage shall be determined by the use of plumb-bobs.
- Coloring of various concrete loads for the exhumed shafts shall be as follows:
 - 1st load shall be of normal color followed by red then black loads.
 - The red load shall be placed normally followed by a 60 minute delay simulating construction difficulties.

7.6 TESTING OF NON-EXHUMED SHAFTS

- Cores
 - Location: Cores should be taken at locations of 5, 15, and 25 feet below the surface of the non-exhumed test.
- Compressive strength, (f_c): ASTM C 39 (1998), Elastic Modulus, (E_c): ASTM C 469 (1998),
 - Testing Age: 56 days (Coring should occur at 51 days)
 - Size: 4 inch core diameter
 - Specimens: 4 x 8 inch
 - Treatment: In accordance with ACI 318 (2002) Section 5.6.5
- Permeability ASTM C 1202 (1998)
 - 3 specimens
 - Cored at 51 days and tested at 91 day

- Size: 4 Ø x 2 inch disks

7.7 TESTING OF EXHUMED SHAFTS

- Cut Cross-Sections:
 - Cross sections shall be cut at locations of 5, 15, and 25 below the surface of the exhumed shaft by means of a specialized wire saw.
 - Visual Assessment of aggregate, coloring of loads, and void distribution shall be conducted for all cut cross-sections.
 - Impact-echo mapping of cross-section's density shall be performed for all cut cross-sections.
 - Extract one 4 Ø x 8 inch core from each cut face for calibration of impact-echo.

7.8 INSTRUMENTATION

- Temperature Profiles using I-Buttons (non-exhumed shafts)
 - I-Buttons should be fixed firmly to steel dowels and placed in 5 feet intervals vertically.
 - The location of the steel dowels shall be 2.5, 7.5, 12.5, 17.5, 22.5, and 27.5 feet below the surface of the shaft.
 - There shall be 9 I-Buttons per dowel and 54 I-Buttons per shaft (Total = 108).
 - Data Collection: The sample interval for the I-Buttons shall be 15 minutes for the first 28 days after placement. After the data has been collected for the first 28 days, the I-Buttons are to be reset at a sample interval of 4 hours for a year.
- Pressure Profile using Load Cells (non-exhumed shafts)
 - There shall be 6 load cells per shaft located at 2.5, 7.5, 12.5, 17.5, 22.5, and 27.5 feet below the surface of the shaft.
- Cross-Hole Sonic Logging (non-exhumed shafts)
 - Cross-hole sonic logging should be conducted at locations of 5, 15, and 25 feet below the surface of the shaft.

CHAPTER 8

SUMMARY, CONCLUSIONS, AND RECOMMENDATIONS

8.1 INTRODUCTION

The laboratory testing program was executed to determine if self-consolidating concrete can be used as a viable material for drilled shaft construction. The primary objectives of this research were to identify appropriate testing techniques, identify characteristics for this specific application, and potential problems or concerns with the use of SCC in drilled shaft construction. Furthermore, the laboratory testing program examined the difference between ordinary drilled shaft concrete and SCC for both fresh and hardened properties. The fresh properties include filling ability, passing ability, segregation resistance, workability over time, bleeding characteristics, and controlled setting, while the hardened properties included the comparison of the compressive strength, elastic modulus, and drying shrinkage. It is hopeful that this research will lead to additional interest in this topic from state and national transportation agencies so that further research in this area can be conducted. This chapter will present the summary and conclusions drawn from this research while offering recommendations based on the summary and conclusions.

8.2 SUMMARY AND CONCLUSIONS

The laboratory testing of the fresh and hardened properties for both the ODSC and SCC mixtures provided insight into the use of SCC for drilled shaft applications.

The results provided in Chapter 6 were thoroughly examined and conclusions were drawn from these results. The following section presents the summary conclusions drawn from this research testing program.

- The use of set-retarding admixtures can significantly increase the time in which a concrete mixture will remain workable. For drilled shaft applications, the dosage of set-retarding admixture should be adjusted to provide an extended initial set necessary to ensure that the workability of the concrete mixture is maintained for the duration of the pour and to allow for any construction delays in concreting and removal of the temporary casing after concreting is completed.
- For a given dosage of set-retarding admixture, concrete mixtures can experience faster initial set times and increased slump loss when exposed to higher temperatures compared to the laboratory conditions.
- This research shows that merely estimating the additional amount of set-retarding admixture needed in hot weather conditions is not a sufficient measure to ensure that proper retained workability and set times are achieved. The amount of retarding admixture should be based on trial mixes under simulated conditions.
- Results indicate that SCC mixtures can experience an increased workability loss compared to ODSC mixtures when subject to similar mixing conditions. The rate and amount of workability loss depends on the initial workability conditions, degree of agitation, rotational speed of the mixing drum, and duration of mixing.
- The SCC mixtures prepared for this research provided a considerable increase in workability at placement compared to the ODSC mixtures. This enhanced

workability may be capable of overcoming placement difficulties associated with tremie placing concrete and congested rebar cages.

- SCC mixtures are more inclined to have a larger change in workability for the same amount of time compared to the ODSC mixtures.
- The Slump Flow, T_{50} , and J-Ring tests were deemed acceptable quality control procedures for both laboratory and field conditions for drilled shaft applications.
- It is a must that the static stability of the SCC mixture be part of the determination of the VSI rating. This should be done by observing the SCC mixture in the wheelbarrow or mixing drum directly after the completion of the slump flow test.
- It is concluded that the segregation column can be used to provide a quick and valuable testing procedure for laboratory purposes to determine the probability of a SCC mixture to segregate, especially at higher values of slump flow.
- The critical sand-to-aggregate ratio for these materials for passing ability and segregation resistance is 0.44 or higher. The possibility of blockage and segregation may be increased at sand-to-aggregate ratios below 0.44.
- The SCC mixtures exhibited increased stability as the water slump and water-to-cementitious materials ratio was reduced, which is more apparent at higher values of slump flow.
- The ODSC mixtures demonstrated a higher degree of bleeding compared to the SCC mixtures prepared at the same water-to-cementitious materials ratio.
- If the moisture variability at the batch plant can be properly controlled and since the SCC mixtures for this research are placed at lower values of slump flow (18 to

24 inches), it is the opinion of the author that very workable and stable SCC mixtures can be achieved without the use of the polyethylene glycol VMA.

- It was concluded for this research that since the fine and coarse aggregates were high quality and the aggregate volume fraction was not drastically different, the modulus of elasticity of the SCC mixtures was not significantly affected by the varying sand-to-aggregate ratio, which ranged from 0.40 to 0.48.
- The results from this research indicate that with these materials and mixture proportions, the equation provided by ACI 318 (2002) typically overestimated the modulus of elasticity especially at higher values of compressive strengths. Conversely, the equation provided by the ACI Committee 363 (2002) was found to provide an improved and conservative estimate of the modulus of elasticity.
- The water-to-cementitious materials ratio appeared to be the main factor influencing the drying shrinkage. The results indicate that the reduction in water-to-cementitious materials ratio decreased the concrete specimen's tendency to shrink.
- It can be concluded that the coefficient of permeability decreases as the water-to-cementitious materials ratio is reduced.
- It can be concluded that the introduction of silica fume can considerably reduce the permeability of concrete.

8.3 RECOMMENDATIONS

- Due to the time-dependent effects of the HRWR admixture, it is recommended that laboratory mixing procedures account for transportation time and the HRWR

admixture be adjusted to account for the transportation time so that SCC mixture will meet the specified quality control limits upon arrival to the job site.

- It is recommended that field adjustments to the chemical admixtures at the job site be avoided; rather all efforts should be made to correctly batch the chemical admixtures at the source of mixing.
- It is highly suggested that trial mixes be conducted under simulated conditions in order to determine the appropriate set-retarding admixture dosage and proper workability retention is achieved.
- It is suggested that the slump flow and J-Ring test be used as quality control test for the SCC mixtures in both the laboratory and field settings. The segregation column test can be used for laboratory purposes.
- In order to overcome placement problems associated with ODSC mixtures it is recommended that the SCC mixtures be placed at a slump flow ranging from 18 to 24 inches with a VSI rating of 1 or less. It is the opinion of the author that these quality control limits will provide a SCC mixture with sufficient flowability, workability, and stability for both dry and wet-hole construction.
- The following suggestions are offered to overcome issues associated with congested rebar cages. Firstly, the use of small well-graded rounded river gravel should be utilized in applications where the rebar cages are congested. In regards to the SCC mixtures, it is suggested that the use of a small well-graded rounded river gravel with a #7 gradation be used to ensure high passing ability and reduced possibility of segregation.

- It is recommended that water-to-cementitious materials ratios of 0.36 to 0.40 be utilized for drilled shaft applications.
- In order to help reduce the amount of bleed water generated the following suggestions are offered:
 1. Use large amounts of supplementary cementitious materials to reduce the amount of free water
 2. Air entrainment
 3. By reducing the free water content or water-to-cementitious materials ratio
 4. Utilizing of new polycarboxylate ester based mid and high range water reducing admixtures
 5. Presence of adequate proportions of very fine aggregate particles, which can consist of raising the sand-to-aggregate ratio
 6. The use of a binding type VMA
- If a low permeability-high durability drilled shaft concrete mixture is required in areas prone to chemical attack, a low water-to-cementitious materials ratio and/or the incorporation of fine material, such as silica fume, should be used to provide the necessary durability.
- It is recommended that the SCC mixture 9:36-44 FA be utilized for the field study to be conducted in South Carolina.
- Establish a “high performance concrete criteria” for drilled shaft construction based on the following:
 1. Workability requirements
 2. Shaft size
 3. Congestion of the rebar cages
 4. Typical aggregate size and type
 5. Retained workability requirements
 6. Avoidance of segregation & bleeding

REFERENCES

- ACI Committee 209. 2002. Prediction of Creep, Shrinkage, and Temperature Effects in Concrete Structures. In *ACI Manual of Concrete Practice 2002: Part 1*. 209R-1-209R-47. Farmington Hills, Missouri: American Concrete Institute.
- ACI Committee 318. 2002. Building Code Requirements for Structural Concrete. In *ACI Manual of Concrete Practice 2002: Part 4*. 363R-1-363R-55. Farmington Hills, Missouri: American Concrete Institute.
- ACI Committee 363. 2002. State-of-the-Art Report on High-Strength Concrete. In *ACI Manual of Concrete Practice 2002: Part 5*. 363R-1-363R-55. Farmington Hills, Missouri: American Concrete Institute.
- ASTM C 31. 1998. Standard Practice for Making and Curing Concrete Test Specimens in the Field. *Annual Book of ASTM Standards* 1998 Section 04, V. 4.02: Concrete and Aggregates.
- ASTM C 33. 2002. Standard Specification for Concrete Aggregates. *Annual Book of ASTM Standards* 2002. Section 04, V. 4.02: Concrete and Aggregates.
- ASTM C 39. 1998. Standard Test Method for Compressive Strength of Cylindrical Concrete Specimens. *Annual Book of ASTM Standards* 1998. Section 04, V. 4.02: Concrete and Aggregates.

- ASTM C 138. 1998. Standard Test Method for Unit Weight, Yield, and Air Content. *Annual Book of ASTM Standards* 1998. Section 04, V. 4.02: Concrete and Aggregates.
- ASTM C 143. 1998. Standard Test Method for Slump of Hydraulic-Cement Concrete. *Annual Book of ASTM Standards* 1998. Section 04, V. 4.02: Concrete and Aggregates.
- ASTM C 157. 1998. Standard Test Method for Length Change of Hardened Hydraulic-Cement Mortar and Concrete. *Annual Book of ASTM Standards* 1998. Section 04, V. 4.02: Concrete and Aggregates.
- ASTM C 172. 1998. Standard Practice for Sampling Freshly Mixed Concrete. *Annual Book of ASTM Standards* 1998. Section 04, V. 4.02: Concrete and Aggregates.
- ASTM C 192. 1998. Standard Practice for Making and Curing Concrete Test Specimens in the Laboratory. *Annual Book of ASTM Standards* 1998. Section 04, V. 4.02: Concrete and Aggregates.
- ASTM C 204. 1998. Standard Test Method for Fineness of Hydraulic Cement by Air Permeability Apparatus. *Annual Book of ASTM Standards* 1998. Section 04, V. 4.02: Concrete and Aggregates.
- ASTM C 232. 1998. Standard Test Method for Bleeding of Concrete using Method A. *Annual Book of ASTM Standards* 1998. Section 04, V. 4.02: Concrete and Aggregates.
- ASTM C 360. 1998. Standard Test Method for Ball Penetration in Freshly Mixed Hydraulic Cement Concrete. *Annual Book of ASTM Standards* 1998. Section 04, V. 4.02: Concrete and Aggregates.

- ASTM C 403. 1998. Standard Test Method for Time of Setting of Concrete Mixtures by Penetration Resistance. *Annual Book of ASTM Standards* 1998. Section 04, V. 4.02: Concrete and Aggregates.
- ASTM C 469. 1998. Standard Test Method for Static Modulus of Elasticity and Poisson's Ratio Strength of Concrete in Compression. *Annual Book of ASTM Standards* 1998. Section 04, V. 4.02: Concrete and Aggregates.
- ASTM C 494. 1998. Standard Specification for Chemical Admixtures for Concrete. *Annual Book of ASTM Standards* 1998. Section 04, V. 4.02: Concrete and Aggregates.
- ASTM C 618. 1998. Standard Specification for Coal Fly Ash and Raw or Calcined Natural Pozzolan for Use in Concrete. *Annual Book of ASTM Standards* 1998. Section 04, V. 4.02: Concrete and Aggregates
- ASTM C 989. 1998. Specification for Ground Granulated Blast Furnace Slag for Use in Concrete and Mortars. *Annual Book of ASTM Standards* 1998. Section 04, V. 4.02: Concrete and Aggregates.
- ASTM C 1202. 1998. Standard Test Method for Electrical Indication of Concrete's Ability to Resist Chloride Ion Penetration. *Annual Book of ASTM Standards* 1998. Section 04, V. 4.02: Concrete and Aggregates.
- ASTM C 1231. 1998. Standard Practice for use of Unbonded Caps in Determination of Compressive Strength of Hardened Concrete Specimens. *Annual Book of ASTM Standards* 1998. Section 04, V. 4.02: Concrete and Aggregates.

- ASTM C XXXX/CXXX. 2004. Standard Test Method for Segregation of Hydraulic-Cement Self-Consolidating Concrete using Column Technique. Proposed ASTM Draft submitted to ASTM for acceptance.
- ASTM C XXXX/CXXX. 2004. Standard Test Method for Passing Ability of Self-Consolidating Concrete by J-Ring and Slump Cone. Proposed ASTM Draft submitted to ASTM for acceptance.
- Attigbe E.K., H.T. See, and Joseph Daczko. 2003. Engineering Properties of Self-Consolidating Concrete. In *First North American Conference on the Design and Use of Self-Consolidating Concrete 12-13 November 2002*, edited by Surendra Shah, Joseph Daczko, and James Lingscheit, 331-336. Addison, Illinois: Hanley-Wood.
- Berke, N.S., C.R. Cornman, A.A. Jeknavorian, G.F. Knight, and O. Wallevik. 2003. The Effective Use of Superplasticizers and Viscosity-Modifying Agents in Self-Consolidating Concrete. In *First North American Conference on the Design and Use of Self-Consolidating Concrete 12-13 November 2002*, edited by Surendra Shah, Joseph Daczko, and James Lingscheit, 165-170. Addison, Illinois: Hanley-Wood.
- Bonen, David and Surendra Shah. 2004. The Effects of Formulation on the Properties of Self-Consolidating Concrete. In *Concrete Science and Engineering: A Tribute to Arnon Bentur: Proceedings of the International RILEM Symposium held in Evanston, USA 24 March 2004*, edited by K. Kovler, J. Marchand, S. Mindess, and J. Weiss, 43-56. Cachan Cedex, France: RILEM Publications s.a.r.l

- Brown, Dan A. 2004. Zen and the Art of Drilled Shaft Construction. In *Geotechnical Special Publication 124*, ASCE, Vol. 124: 19-33.
- Brown, Dan A. 2004. Concrete. Presentation presented as part of the ADSC Short Course for Drilled Shaft Foundations.
- Brown, Dan A. 2004. Personal Commutation.
- Bury, M.A. and B.J. Christensen. 2003. The Role of Innovative Chemical Admixtures in Producing Self-Consolidating Concrete. In *First North American Conference on the Design and Use of Self-Consolidating Concrete 12-13 November 2002*, edited by Surendra Shah, Joseph Daczko, and James Lingscheit, 137-140. Addison, Illinois: Hanley-Wood.
- California Department of Transportation (Caltrans). 2004. Manual and Forms. <http://www.dot.ca.gov>
- California Department of Transportation (Caltrans). 2004. Photographs taken by Caltrans (Chapter 3) were provided by Dr. Dan Brown with permission. <http://www.dot.ca.gov>
- Camp, W.M, Dan A. Brown, and P.W Mayne. 2002. Construction Methods Effects on Axial Drilled Shaft Performance. *Geotechnical Special Publication 116*, ASCE: 193-208.
- Degussa Construction Materials. 2004. Master Builders Admixture Systems. <http://www.masterbuilders.com>
- Emborg, Mats. 1999. Rheology Tests for Self-Compacting Concrete-How Useful are they for the Design of Concrete Mix for Full Scale Production? In *Self-Compacting Concrete: Proceedings of the First International RILEM Symposium*

- held in Stockholm, Sweden 13-14 September 1999*, edited by A. Skarendahl and O. Petersson, 95-105. Cachan Cedex, France: RILEM Publications s.a.r.l
- Ferraris, Chiara F., Karthik H. Obla, and Russell Hill. 2001. The Influence of Mineral Admixtures on the Rheology of Cement Paste and Concrete. *Cement and Concrete Research* 31: 245-255.
- Florida Department of Transportation (FDOT). 2004. Photographs taken by FDOT (Chapter 3) were provided by Dr. Dan Brown with permission.
<http://www.dot.state.fl.us>
- Gerwick Jr., Ben C. 2004. Placement of Tremie Concrete. *Concrete International* (January): 41-52.
- Hodgson, Donald (Trey) Nelson. 2003. Laboratory and Field Investigations of Self-Consolidating Concrete. M.S. Thesis., University of Auburn.
- Jones, Krista. 2004. The Age-Dependent Stiffness Development of Concrete. M.S. Thesis., University of Auburn.
- Khayat, Kamal, C. Hu, and H. Monty. 1999. Stability of Self-Consolidating Concrete, Advantages, and Potential Applications. In *Self-Compacting Concrete: Proceedings of the First International RILEM Symposium held in Stockholm, Sweden 13-14 September 1999*, edited by A. Skarendahl and O. Petersson, 143-152. Cachan Cedex, France: RILEM Publications s.a.r.l
- Khayat, Kamal, Joseph Assaad, and Joseph Daczko. 2004. Comparison of Field-Oriented Test Methods to Assess Dynamic Stability of Self-Consolidating Concrete. *ACI Materials Journal* v. 101, n. 2, (March-April): 168-172.

- Khayat, Kamal and Joseph Daczko. 2003. The Holistic Approach to Self-Consolidating Concrete. In *First North American Conference on the Design and Use of Self-Consolidating Concrete 12-13 November 2002*, edited by Surendra Shah, Joseph Daczko, and James Lingscheit, 9-14. Addison, Illinois: Hanley-Wood.
- Khayat, Kamal and Somnuk Tangtermsirikul. 2000. Fresh Concrete Properties. In *State-of-the-Art Report (23) of RILEM Technical Committee 174-SCC*, edited by A. Skarendahl and O. Petersson, 17-22. Cachan Cedex, France: RILEM Publications s.a.r.l.
- Kim, Jin-Keun, Sang Hun Han, Yon Dong Park, and Jae Ho Noh. 1998. Materials Properties of Self-Flowing Concrete. *Journal of Materials in Civil Engineering*. (July): 244-249.
- Mapquest. 2005. Mapquest.com Maps, Directions and more.
<http://www.mapquest.com>
- Mindess, Sidney, J. Francis Young, and David Darwin. 2003. *Concrete*, 2nd edition. Upper Saddle River, NJ: Prentice Hall.
- Mujtaba, Ghulam. 2004. *Supplemental Technical Special Provisions for use of Flowing Concrete and Self-Consolidating Concrete for Manufacturing of Precast/Prestressed Concrete Products*, Florida Department of Transportation. Gainesville, Florida: State Materials Office.
- Neville, A.M. 1996. *Properties of Concrete*, 4th edition. New York: John Wiley & Sons, Inc.

- O'Neill, Michael W. and Lymon C. Reese. 1999. *Drilled Shafts: Construction Procedures and Design Methods*, FHWA Report No. FHWA-IF-99-025, Vol. I, Chapters 1-8: Dallas, Texas: ADSC: The International Association of Foundation Drilling.
- Okamura, Hajime and Masahiro Ouchi. 1999. Self-Compacting Concrete. Development, Present Use and Future. In *Self-Compacting Concrete: Proceedings of the First International RILEM Symposium held in Stockholm, Sweden 13-14 September 1999*, edited by A. Skarendahl and O. Petersson, 3-14. Cachan Cedex, France: RILEM Publications s.a.r.l
- Petersson, Orjan. 1999. Workability. In *Final Report of Task2: Brite-EuRam project BRPR-CT96-0366*, <http://scc.ce.luth.se/public/report/workability>
- Petersson, Orjan. 2000. L-Shape Box Test. In *State-of-the-Art Report (23) of RILEM Technical Committee 174-SCC*, edited by A. Skarendahl and O. Petersson, 126-128. Cachan Cedex, France: RILEM Publications s.a.r.l.
- Precast/Prestressed Concrete Institute (PCI). 2003. *Interim Guidelines for the Use of Self-Consolidating Concrete in Precast/Prestressed Concrete Institute Member Plants*, 1st edition. Chicago Illinois: Precast/Prestressed Concrete Institute.
- Raghavan, K.P., Sivarama Sarma, and D. Chattopadhyay. 2003. Creep, Shrinkage and Chloride Permeability Properties of Self-Consolidating Concrete. In *First North American Conference on the Design and Use of Self-Consolidating Concrete 12-13 November 2002*, edited by Surendra Shah, Joseph Daczko, and James Lingscheit, 307-312. Addison, Illinois: Hanley-Wood.

- Ramsburg, Paul. 2003. The SCC Test: Inverted or Upright. *Concrete Producer* v 21, n 7, (July): 34-38.
- Rols, Sebastien, Jean Ambroise, and Jean Pera. 1999. Effect of Different Viscosity Agents on the Properties of Self-Leveling Concrete. *Cement and Concrete Research* 29: 261-266.
- Sedran, T. 2000. Rheology. In *Final Report of Task 3: Brite-EuRam project BRPR-CT96-0366*, <http://scc.ce.luth.se/public/report/rheology>
- Skarendahl, Ake. 2000. Definitions. *Self-Compacting Concrete*, In *State-of-the-Art Report (23) of RILEM Technical Committee 174-SCC*, edited by A. Skarendahl and O. Petersson, 3-5. Cachan Cedex, France: RILEM Publications s.a.r.l.
- Sonebi, M., and P.J.M. Bartos. 1999. Hardened SCC and its Bond with Reinforcement. In *Self-Compacting Concrete: Proceedings of the First International RILEM Symposium held in Stockholm, Sweden 13-14 September 1999*, edited by A. Skarendahl and O. Petersson, 275-289. Cachan Cedex, France: RILEM Publications s.a.r.l
- South Carolina Department of Transportation. 2004. Standard Specifications. <http://www.dot.state.sc.us>
- Su, J.K., S.W. Cho, C.C. Yang, and R. Huang. 2002. Effect of Sand Ratio on the Elastic Modulus of Self-Compacting Concrete. *Journal of Marine Science and Technology*, V.10, N.1: 8-13.
- Su, Nan, Kung-Chung Hsu, and His-Wen Chai. 2001. A Simple Mix Design Method for Self-Compacting Concrete. *Cement and Concrete Research* V. 31. (December 2001): 1799-1807.

- Takada, Kazunori and Somnuk Tangtermsirikul. 2000. Testing of Fresh Concrete. *Self-Compacting Concrete*, In *State-of-the-Art Report (23) of RILEM Technical Committee 174-SCC*, edited by A. Skarendahl and O. Petersson, 25-39. Cachan Cedex, France: RILEM Publications s.a.r.l.
- Texas Department of Transportation (TxDOT). 2004. Photographs taken by TxDOT (Chapter 3) were provided by Dr. Dan Brown with permission.
<http://www.dot.state.tx.us>
- Tragarch, J. 1999. Microstructural Features and Related Properties of Self-Compacting Concrete. In *Self-Compacting Concrete: Proceedings of the First International RILEM Symposium held in Stockholm, Sweden 13-14 September 1999*, edited by A. Skarendahl and O. Petersson, 175-186. Cachan Cedex, France: RILEM Publications s.a.r.l
- Turcry, P., A. Loukili, and K. Haidar. 2003. Mechanical Properties, Plastic Shrinkage and Free Deformation of Self-Consolidating Concrete. In *First North American Conference on the Design and Use of Self-Consolidating Concrete 12-13 November 2002*, edited by Surendra Shah, Joseph Daczko, and James Lingscheit, 301-306. Addison, Illinois: Hanley-Wood.
- Yao, Sam X. and Ben C. Gerwick, Jr. 2004. Underwater Concrete: Part 2 Proper Mixture Proportioning. *Concrete International* (February): 77-82.