

# **Stability of Timber Bridges Subject to Scour**

by

Mary Eudora Schambeau

A thesis submitted to the Graduate Faculty of  
Auburn University  
in partial fulfillment of the  
requirements for the Degree of  
Master of Science in Civil Engineering

Auburn, Alabama  
August 4, 2012

Keywords: scour, timber, bridges, structural health monitoring

Copyright 2012 by Mary Eudora Schambeau

Approved by

James S. Davidson, Ph.D., Associate Professor of Civil Engineering  
Mary L. Hughes, Ph.D., Instructor of Civil Engineering  
G. Ed Ramey, Ph.D., Professor Emeritus of Civil Engineering  
Justin D. Marshall, Ph.D., Assistant Professor of Civil Engineering

## **ABSTRACT**

Because scour is responsible for most disastrous bridge failures, bridge scour monitoring is necessary for the safety of public roads. While much attention is paid to the amount of bridge scour at a foundation, the structural stability implications of the loss of embedment due to scour are not easily assessed. To fill this need, an automated screening tool for the evaluation of timber pile bents was developed. The tool examines five failure modes of timber piles and timber bents: kick-out of a bent due to zero or negligible embedment after scour; pile plunging due to soil failure; pile buckling failure in either the longitudinal or transverse direction; bent pushover failure due to the combined effects of superstructure gravity loading and loading from the lateral debris raft load; and beam-column failure of the upstream pile due to the combined lateral debris raft load and axial gravity loading. The automated screening tool was programmed using Visual Studio 2005 and 2010 software package. A series of forms allow the user to input bent geometry and scour conditions for the bent under assessment, then the program will internally evaluate the structural stability. A printable report is also provided to supply documentation of the stability analyses.

## **ACKNOWLEDGEMENTS**

I would like to thank my advisors, Dr. Davidson, Dr. Hughes, and Dr. Ramey for all their help on this project. Without their experience, this work could not have been completed. As this research was prepared under cooperative agreement between the Alabama Department of Transportation (ALDOT) and the Highway Research Center (HRC) at Auburn University, I am grateful to the ALDOT and HRC for their sponsorship and support of the work in addition to the assistance and guidance of several ALDOT engineers during the execution of the research work. Specifically, thanks are due to James Bearrentine, Eric Christie, George Connor, and Ashley Mock of ALDOT. Also, this work could not have been completed without assistance from members of Engineering Network Services, specifically Nabeel Rawajfih and Jamie Jones.

## TABLE OF CONTENTS

Abstract .....	ii
Acknowledgments .....	iii
List of Tables.....	vii
List of Figures.....	x
List of Nomenclature .....	xiii
Chapter 1 Introduction.....	1
1.1 Problem Statement .....	1
1.2 Research Objective .....	2
1.3 Work Plan .....	5
Chapter 2 Literature Review.....	4
2.1 National Bridge Inspection Standards .....	4
2.2 Scour Failure of Bridges .....	6
2.3 Scour Monitoring Practices .....	8
2.4 Structural Analysis of Scour Critical Bridges .....	11
2.5 Material Properties of Timber Piles .....	15
2.6 Review of Visual Studio and Visual Basic Code Writing (VBA) .....	21
Chapter 3 Scour Monitoring of Country Bridges Supported on Timber Pile Bents .....	22
3.1 General .....	22
3.2 Bridge Parameter Values Needed to Assess Bridge Stability .....	24

3.3 Possible Failure Modes of Timber Pile Bents .....	24
3.4 Typical Value Ranges of Alabama County Bridges .....	25
3.5 Material Assumption Used in Screening Tool .....	27
3.6 Debris Raft Consideration for Small Span Bridges .....	30
Chapter 4 Failure Modes for Timber Bents Subject to Scour .....	33
4.1 General .....	33
4.2 Kick-out Failure .....	33
4.3 Pile Plunging by Soil Failure .....	35
4.4 Bent Pile Buckling Failure .....	46
4.5 Bent Pushover Failure .....	59
4.6 Beam-Column Failure .....	72
Chapter 5 Screening Tool Flowcharts .....	80
5.1 General .....	80
5.2 Screening Tool Macro-Flowchart .....	80
5.3 Screening Tool Micro-Flowcharts .....	82
Chapter 6 Automation of the Screening Tool Using Visual Studio .....	89
6.1 General .....	89
6.2 Preliminary Input Analysis .....	92
6.3 Kick-out and Plunging Analysis .....	97
6.4 Buckling Evaluation .....	103
6.5 Pushover Evaluation .....	105
6.6 Beam-Column Evaluation .....	108
6.7 Conclusions and Output Report .....	109

Chapter 7 Automatic Screening Tool Post-Analyses.....	115
7.1 General .....	115
7.2 Buckling Post-Analyses .....	115
7.3 Plunging Post-Analysis .....	133
7.4 Bent Pushover Post-Analyses .....	139
7.5 Beam-Column Post-Analyses .....	141
Chapter 8 Conclusions .....	143
References .....	146
Appendix A: X-Braced Timber Pile Bent $F_t$ vs. $\Delta$ Pushover Curves.....	150
Appendix B: Unbraced Timber Pile Bent $F_t$ vs. $\Delta$ Pushover Curves .....	224
Appendix C: Beam Column Analyses.....	279
Appendix D: Automated Screening Tool Visual Basic Code .....	296

## LIST OF TABLES

Table 2.1 Critical Ratings for Item 113 of SI&A Guide: Scour Critical Bridges (FHWA 1995) .....	6
Table 2.2 Typical Limiting Dimensions for Piles, Inches (Chellis 1961).....	16
Table 2.3 Approximate Elastic Modulus and Strengths of Woods Commonly Used for Timber Piles in Alabama (Chellis 1961) .....	18
Table 2.4 Load Duration Modification Factors for Timber (Schaeffer 1980).....	18
Table 2.5 Timber Pile Material Properties Used in Screening Tool .....	19
Table 2.6 Geometric Properties of Select Timber Utility Poles (Quintero 1980).....	20
Table 3.1 Timber Pile Material Properties Used in Screening Tool .....	28
Table 3.2 Typical Effective Section Properties for Common Pile Sizes.....	30
Table 4.1 Common Driving Resistance Ranges (Bowles 1968).....	38
Table 4.2 Estimated Hammer Efficiencies.....	38
Table 4.3 Predicted Pile Capacities Based on Modified Gates Formula for Timber Piles with F.S. = 1.25.....	43
Table 4.4 Assumed Fixity Conditions Based on Embedment Length.....	47
Table 4.5 Critical Longitudinal Buckling Lengths and Critical Scour for Various Bent Parameters (E = 1,800 ksi, F.S. = 1.33).....	51
Table 4.6 Critical Transverse Sidesway Buckling Lengths and Critical Scour for Various Braced Bent Parameters (E = 1,800 ksi, F.S. = 1.33) .....	56

Table 4.7 Critical Transverse Sidesway Buckling Lengths and Critical Scour for Various Unbraced Bent Parameters ( $E = 1,800$ ksi, $F.S. = 1.33$ ) .....	58
Table 4.8 Equations for Buckling for Braced and Unbraced Bents.....	59
Table 4.9 Timber Pile Bent Cases Analyzed for Pushover.....	65
Table 4.10 Pushover Loads $F_t$ for Braced, 12" Pile Butt Diameter Bents .....	66
Table 4.11 Pushover Loads $F_t$ for Braced, 14" Pile Butt Diameter Bents .....	68
Table 4.12 Pushover Loads $F_t$ for Unbraced, 12" Pile Butt Diameter Bents.....	70
Table 4.13 Pushover Loads $F_t$ for Unbraced, 14" Pile Butt Diameter Bents.....	71
Table 4.14 Beam-Column Analysis Evaluations for Multiple Bent Geometries .....	78
Table 7.1 Critical Transverse Sidesway Buckling Lengths and Scour Depths for Braced Bents, 12 in. Pile Butt Diameter, 20 ft Pile Embedment .....	116
Table 7.2 Critical Scour Values for Transverse and Longitudinal Buckling for Braced Bents, 12 in. Pile Butt Diameter, 20 ft Pile Embedment .....	117
Table 7.3 Corresponding Allowable Loads based on Critical Scour for Braced Bents, 12 in. Pile Butt Diameter, 20 ft Pile Embedment .....	119
Table 7.4 Difference in Effective Moment of Inertia Based on Buckling Mode .....	120
Table 7.5 Critical Bent Heights for Longitudinal Buckling Control .....	122
Table 7.6 Critical Scour Values for Transverse and Longitudinal Buckling for Braced Bents, 12 in Pile Butt Diameter, 18 ft Pile Embedment .....	125
Table 7.7 Corresponding Allowable Loads based on Critical Scour for Braced Bents, 12 in. Pile Butt Diameter, 18 ft Pile Embedment .....	126
Table 7.8 Critical Scour Depths for Buckling for Braced and Unbraced Bents (16 ft Bent Height, 14 in. Pile Butt Diameter, 20 ft Pile Embedment).....	128



Table 7.9 Effective Moment of Inertia for Varying Scour Depths.....	129
Table 7.10 Critical Scour Depths for Buckling for Braced Bent (20 ft Bent Height, 12 in. Pile Butt Diameter, 20 ft Pile Embedment.....	131
Table 7.11 Iteration Example for Most Conservative Critical Scour Depth (14 ft Bent Height, 12 in. Pile Butt Diameter, 30 ft Pile Embedment, 50 kip P-Load, Braced Bent) .....	133
Table 7.12 Pile Plunging Capacities and Critical Scours for Plunging Failure (4 bpi Driving Resistance, 13,000 lb-ft Drop Hammer, 20 ft Pile Embedment) .....	134
Table 7.13 Pile Plunging Capacities and Critical Scours for Plunging Failure (5 bpi Driving Resistance, 13,000 lb-ft Drop Hammer, 20 ft Pile Embedment) .....	136
Table 7.14 Pile Plunging Capacities and Critical Scours for Plunging Failure (5 bpi Driving Resistance, 13,000 lb-ft Drop Hammer, 15 ft Pile Embedment) .....	137
Table 7.15 Pile Plunging Capacities and Critical Scours for Plunging Failure (5 bpi Driving Resistance, 13,000 lb-ft Diesel Hammer, 15 ft Pile Embedment) .....	138
Table 7.16 Percent Increase in Plunging Capacity Based on Hammer Efficiency.....	138
Table 7.17 Pushover Forces for 4-pile Unbraced Steel and Timber Bents, kips .....	140
Table 7.18 Bent Pushover Forces for Unbraced 4-pile <b>HP<sub>12x42</sub></b> Steel Bent, kips .....	141
Table 7.19 Allowable Scour Depths and Allowable Loads for Beam-Column Evaluation for Braced Timber Bents and Large Debris Rafts .....	142

## LIST OF FIGURES

Figure 2.1 Plan and Elevation View of Local Scour (Maddison 2012) .....	7
Figure 2.2 Typical Timber Pile (Quintero 1980).....	15
Figure 3.1 Typical Timber Pile Bents (provided by ALDOT).....	22
Figure 3.2 Transverse Section of Typical Timber Bridges with Information Needed to Assess Adequacy During an Extreme Scour Event .....	24
Figure 3.3 Alabama County Timber Pile Bent Ranges of Critical Assessment Parameters .....	27
Figure 3.4 Effective Section of Embedded Timber Pile (Ramey et al. 2011).....	28
Figure 3.5 Variation of Pile Effective Moment of Inertia versus Pile Diameter.....	29
Figure 3.6 Debris Raft Force Calculation for Small Span Bridges.....	32
Figure 4.1 Pile Tip Kick-out Failure .....	34
Figure 4.2 Pile Axial Resistance.....	36
Figure 4.3 Elevations Schematics of Timber and Steel Wide Flange Piles .....	37
Figure 4.4 Plunging Capacity Curves for 12,000 k-ft Driving Energy, 4 bpi Driving Resistance by Modified Gates Formula .....	44
Figure 4.5 Buckled Shape and Coordinate Axes.....	46
Figure 4.6 Longitudinal Buckling Failure Mode for Braced and Unbraced Bents .....	49
Figure 4.7 Critical Scour ( $S_{cr}$ ) versus Bent Height (H) for Longitudinal Buckling for	

Timber Pile Bent (F.S. = 1.33).....	52
Figure 4.8 Buckling in the Transverse Directions for Braced Bents .....	53
Figure 4.9 Critical Buckling Lengths for Braced Bents over Water .....	54
Figure 4.10 Sidesway Buckling of Unbraced Timber Bents.....	57
Figure 4.11 Stress-Strain Curve for Nonlinear Pushover of Timber Bents .....	60
Figure 4.12 Typical Braced Bent Pushover Failure .....	61
Figure 4.13 Critical Debris Raft Location for Pushover Failure.....	62
Figure 4.14 Bent Pushover Curve for 3-pile, 12 ft Bent Height, 14 in. Pile Butt Diameter, 20 kip P-Load, and No Scour .....	64
Figure 4.15 Beam-Column Failure for Typical Braced Bent .....	72
Figure 4.16 Assumed Ultimate and Allowable Load Interaction Equations .....	73
Figure 4.17 Beam-Column Analysis for 3-Pile Braced Bent (Bent Height = 12 ft, Scour = 20 ft, Pile Butt Diameter = 12 in.) .....	77
Figure 5.1 Screening Tool (ST) Macro-Flowchart .....	81
Figure 5.2 Screening Tool (ST) Micro-Flowchart Schematic.....	83
Figure 5.3 Screening Tool Flowchart Block 1 – Preliminary Evaluation .....	84
Figure 5.4 Screening Tool Flowchart Block 2 – Kick-out and Plunging Evaluation .....	85
Figure 5.5 Screening Tool Flowchart Block 3 – Buckling Evaluation.....	86
Figure 5.6 Screening Tool Flowchart Block 4 – Bent Pushover Evaluation.....	87
Figure 5.7 Screening Tool Flowchart Block 5 – Beam-Column Evaluation .....	88
Figure 6.1 Opening Form for Timber Stability Tool .....	90
Figure 6.2 General Help Dialog Box.....	91
Figure 6.3 Preliminary Evaluation Form .....	93

Figure 6.4 Preliminary Evaluation Help Dialog Box .....	94
Figure 6.5 Example Critical Section Loss Alert Dialog Box .....	95
Figure 6.6 Input Form for Maximum Pile and Bent Loads .....	96
Figure 6.7 Pile and Bent Applied Loads Help Dialog Box.....	97
Figure 6.8 Plunging Evaluation Form Showing Input .....	98
Figure 6.9 Plunging Help Dialog Box.....	99
Figure 6.10 Kick-out Evaluation Dialog Box for All Piles Safe .....	100
Figure 6.11 Kick-out Evaluation Dialog Box for Certain Piles Unsafe .....	101
Figure 6.12 Plunging Evaluation Form Showing Input and Output.....	102
Figure 6.13 Buckling Evaluation Form.....	104
Figure 6.14 Bent Pushover Evaluation Form.....	106
Figure 6.15 Beam-Column Evaluation Form .....	108
Figure 6.16 Final Conclusions Form.....	109
Figure 6.17 Conclusions and Printing Help Dialog Box.....	110
Figure 6.18 Printing Form.....	111
Figure 6.19 Print Preview of Printable Output Report.....	112
Figure 6.20 Example Output Report (Page 1 of 2) .....	113
Figure 6.21 Example Output Report (Page 2 of 2) .....	114
Figure 7.1 Estimated Scour Effect on Effective Section Selection .....	130

## LIST OF NOMENCLATURE

ALDOT	Alabama Department of Transportation
bpi	blows per inch
C	buckling coefficient
$C_D$	drag coefficient
$d_{butt}$	pile diameter at butt location, inches
$d_{eff}$	pile diameter at effective section location, inches
$d_{tip}$	pile diameter at tip location, inches
$d_w$	depth of water under bent, feet
E	modulus of elasticity (Young's modulus), ksi
F.S.	factor of safety
$F_t$	lateral debris raft force or pushover force, kips
ft	feet
ft-lb	foot-pound
FHWA	Federal Highway Administration
H	bent height from top of cap to the new ground line, feet
HB	horizontal brace
HWL	high water line during flood event
$I_{eff}$	moment of inertia of effective section, in <sup>4</sup>
$I_{eff_L}$	effective moment of inertia for longitudinal buckling of braced bent, in <sup>4</sup>

$I_{eff_T}$	effective moment of inertia for transverse buckling of braced bent, in <sup>4</sup>
in.	inch
k-ft	kip-feet
ksi	kips per square inch
L	total pile length including embedment below ground line, feet
$l_{cr}$	critical buckling length that will cause failure, feet
$L_{ag}$	length of pile above ground after scour event (from pile cap to NGL), feet
$L_{as}$	length of pile below ground after scour event (from NGL to pile tip), feet
$L_{bg}$	length of pile below ground before scour event (from OGL to pile tip), feet
$M_{max}$	maximum moment on pile, k-ft
$M_{rupture}$	moment that will cause rupture of the pile, k-ft
NBIS	National Bridge Inventory System
NGL	new ground line elevation after scour event
OGL	original ground line elevation before scour event
P	gravity concentrated load on pile from superstructure, kips
$P_{allowable}$	gravity concentrated load pile can carry without failure, kips
$P_{cr}$	critical gravity concentrated load that will cause failure, kips or tons
$P_{crL}$	critical gravity load that will cause longitudinal buckling failure, kips
$P_{crT}$	critical gravity load that will cause transverse buckling failure, kips
$P_{crusing}$	critical gravity concentrated load that will cause crushing failure, kips or tons
$P_{allowable}$	gravity load pile can carry without failure with included factory of safety, kips
$P_{end-bear}$	gravity load pile can carry in end-bearing without plunging failure, tons

$P_{friction}$	gravity load pile can carry in friction without plunging failure, tons
$L_{bg}$	length of pile below ground before scour event (from OGL to pile tip), feet
S	scour value, feet
$S_{cr}$	critical scour value that will cause failure, feet
$S_{eff}$	section modulus at effective section location, in <sup>3</sup>
SI&A	Structural Inventory and Appraisal
$S_{max}$	maximum estimated scour value at bent or pile, feet
ST	screening tool
VBA	Visual Basic Code
$\sigma_{crushing}$	pile stress that will cause crushing failure, ksi
$\Phi$	diameter of pile, inches

# **CHAPTER 1**

## **INTRODUCTION**

### **1.1 Problem Statement**

For bridges over water, extreme flood events must be considered when assessing the safety of the structure. Excessive scour at the ground line can produce a significant loss of embedment, leading to stability failure. In addition, debris collected by the flood waters can accumulate on bents, producing a lateral force. Timber pile bents are a common substructure utilized by counties for bridges over water. These bridges are used on low-volume roads, but the quantity of them is much greater than that of highway bridges that generally use concrete or steel piles.

A screening tool for the evaluation of bridges subject to scour has been created by Auburn University for the Alabama Department of Transportation (ALDOT) for bridges that have steel piles. By directive of the federal government, ALDOT is also tasked with the scour evaluation of county bridges. Since this includes a large number of bridges, an automated screening tool for timber pile bents was thought to be exceptionally beneficial to ALDOT as they complete this obligation.

### **1.2 Research Objective**

The possible failure modes of timber pile bents were identified and the calculation of critical scour depths associated with those failure modes was accomplished. Failure modes and investigative procedures used in the manual (non-



automated) version of the screening tool were previously outlined in the Milestone No. 1 report (Ramey et al. 2010). The discussion is continued in this thesis to include a description of the automation of the screening tool. While the manual tool is useful, a computer-automated tool is more beneficial for ALDOT. With a computerized tool, they can screen timber bents more rapidly, and with a printable output report, documentation will be streamlined. When an atypical bent is encountered, the manual tool procedures can be referenced in order to screen the bent.

### **1.3 Work Plan**

The automation of the screening tool adhered to the following work plan:

- (1) Familiarization with stability failure modes outlined in the manual screening tool, especially the manual screening tool flowcharts that provide a basis for code procedures;
- (2) Familiarization with Visual Studio 2005 /2010 and Visual Basic code including tutorials outlined in *Microsoft Visual Basic 2005: Step by Step* (Halvorson 2006) to prepare for coding process;
- (3) Familiarization with the previous screening tool for steel piles to gain an understanding of the type of presentation expected by ALDOT and to pinpoint areas that could be updated for the tool to become more accessible;
- (4) Coding of the timber screening tool using Visual Basic (VBA) code;
- (5) Collaboration with ALDOT employees for feedback to better suit the tool for their needs;
- (6) Development of a printable output report with assistance from personnel in the Engineering Network Services Department at Auburn University;

- (7) Preparation of a final report for ALDOT, in conjunction with a final seminar, to present the finished product.

## **CHAPTER 2**

### **LITERATURE REVIEW**

Bridge scour is the erosion of bed material around bridge foundations due to water flow typically associated with granular stream or river beds (Maddison 2012). A literature review focusing on the current research in bridge scour monitoring was conducted to develop a full understanding of the scour problem. Because a federal mandate was the driving force behind this research, the applicable legislation related to all state highway departments' bridge monitoring programs was reviewed. The mechanics of scour and current scour monitoring practices were considered. The current analysis procedures of scour-affected bridges was reviewed, including those procedures previously employed by Auburn University personnel for the development of a steel stability screening tool. A smaller literature review was also conducted focusing on the material properties of timber in order to distinguish reasonable material assumptions for use in the screening tool. Finally, because the ultimate goal of the research was to produce a computer-automated screening tool, a review of Visual Basic code writing was necessary.

#### **2.1 National Bridge Inspection Standards**

The inspection and upkeep of all bridges on public roads is mandated by the Federal Highway Administration (FHWA), with the responsibility falling on each state's department of transportation to comply according to the Code of Federal Regulations, Title 23, Part 650 "Bridges, Structures, and Hydraulics" (2004). Bridge inspection,

specifically, is covered under Subpart C, National Bridge Inspection Standards (NBIS) of the Code. According to the Code, “each State transportation department must inspect, or cause to be inspected, all highway bridges located on public roads that are fully or partially located within the State’s boundaries”. The Alabama Department of Transportation (ALDOT), as of April 2012, is in charge of 2,217 state and county bridges. ALDOT must provide a bridge inspection section accountable for proper inspection of bridges, compilation of a comprehensive bridge inventory, and determination of up-to-date load rating of its bridges. This team is comprised of hydraulic, geotechnical, and structural engineers (Hunt 2005).

Inspection of bridges is the section’s first priority. According to FHWA, routine inspections of bridges should occur on minimum 24-month (2 year) intervals, while underwater inspections should occur on 60-month (5 year) intervals. During inspection, problems such as “scour critical” bridges should be identified. After identification, a strategy must be formed to attend to the scour issues and to observe the bridge for further scour issues. In addition, the safe load-rating of the bridge must be determined. While a bridge with severe scour problems may need to be closed, some affected bridges may remain open under a load restriction.

In addition to an inspection, an inventory of the State’s bridges must be produced and maintained. The inventory should contain Structural Inventory and Appraisal (SI&A) data as defined by the “Recording and Coding Guide for the Structure Inventory and Appraisal of the Nation’s Bridges” (1995). Required data include logistical information such as location, geometrical information such as span and deck widths, load rating information, et cetera, in addition to the structural evaluation of the bridge.

Maintenance of such a database allows for successful bridge supervision and therefore public safety. Many past bridge failures were preventable, but improper inspection and inadequate repairs led to a catastrophe (Maddison 2012).

“Scour Critical Bridges” are designated as Item 113 of the SI&A guide. If a bridge review produces a rating of 4 or less, the load-rating of the bridge must be reevaluated. A summary of the critical road ratings can be seen in Table 2.1.

**Table 2.1 Critical Ratings for Item 113 of SI&A Guide:  
Scour Critical Bridges (FHWA 1995)**

Rating	Description
4	Bridge foundations determined to be stable for calculated scour conditions; field review indicates action is required to protect exposed foundations from effects of additional erosion and corrosion.
3	Bridge is scour critical; bridge foundations determined to be unstable for calculated scour conditions: scour within limit of footing or piles or scour is below spread-footing base or pile tips.
2	Bridge is scour critical; field review indicates that extensive scour has occurred at bridge foundations. Immediate action is required to provide scour countermeasures.
1	Bridge is scour critical; field review indicates that failure of piers/abutments is imminent. Bridge is closed to traffic.
0	Bridge is scour critical; bridge has failed and is closed to traffic.

Due to the large volume of bridges under ALDOT jurisdiction, it was thought that a screening tool would greatly alleviate some of the difficulty in maintaining the NBIS bridge inventory. The automated screening tool’s help would be twofold: to streamline the inspection process and to provide printable documentation for the bridge inventory.

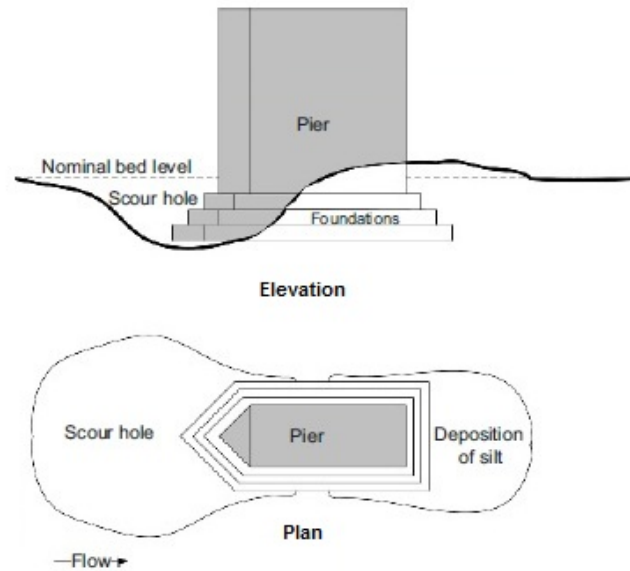
**2.2 Scour Failure of Bridges**

According to FHWA, of the 590,000 bridges in their inventory, 26,472 bridges are scour critical. In addition, scour related problems are responsible for over 60% of bridge failures (Hunt 2005). An average annual cost of bridge repairs related to scour damage

is \$50 million (Bennett et al. 2009). Due to this economic and safety hazard, scour and its effects are heavily-researched topics.

Scour can be categorized into three major types: channel instability, contraction scour, and local scour (Maddison 2012). Channel instability, or natural scour, is the normal amount of erosion all flowing water bodies experience. However, because the amount of scour increases with increases in water flow, severe scour can occur during flooding or periods of extreme runoff. A dramatic increase in flow, and consequently scour, can also occur due to dredging near the bridge site, formation of debris rafts, or collapse of other structures local to the bridge site.

Contraction scour occurs when the stream or river experiences a dramatic decrease in cross-section. When the cross-section decreases, the flow velocity increases, thereby generating more scour. Finally, local scour is attributed to the incidence of an obstruction, such as a pile, in the channel. Because the water must flow around the pier, turbulence is created. This turbulence uplifts the bed material upstream of the pile and deposits the material behind the pile as shown in Figure 2.1 (Maddison 2012).



**Figure 2.1 Plan and Elevation View of Local Scour (Maddison 2012)**

Maddison (2012) also outlines several United Kingdom bridge failures attributed to scour. A fatal 1987 bridge collapse in Glanrhyd during heavy rainfall was attributed to local scour in addition to minor channel instability. It was determined in the post-failure investigation that the engineers did not fully understand the flow of the channel, foundation depths were unknown, and previous repairs had actually increased scour (Maddison 2012).

In a separate case study, a railway bridge in Bighton partially collapsed in 2003 due to contraction scour. A very deep scour hole developed around the bridge pier, resulting in a much shallower foundation than was originally present. The center pier collapsed into the hole, while the arch being supported by the pier partially fell in. Underwater inspections had been conducted by maintenance personnel, but no scour hole had been reported prior to collapse. Also, it was noted that the scour most likely took place during winter flooding, but the failure was not reported until the summer (Maddison 2012).

These oversights illustrate the necessity of maintaining a comprehensive bridge monitoring program executed by trained personnel. Maddison concludes that while extensive time and effort are put into forensic investigations after a bridge failure, “if that same effort could be put into bridge management regimes, collapses could be avoided.” It was also noted that while extensive documentation on a structure exists, it is not often readily available to the engineers during the bridge design process or to the engineers conducting the underwater investigations. The prevalence of computers, however, should “now make it easy to rectify this problem” (Maddison 2012).

### **2.3 Scour Monitoring Practices**

Because of the safety risk associated with the failure of bridges, in addition to the federal mandate, countermeasures must be employed to manage or impede scour. Counter measures are typically either hydraulic, structural, or monitoring countermeasures (Hunt 2005). Hydraulic measures may consist of redirecting flow, while structural measures incorporate amendments made to the bridge substructure. Scour monitoring, however, is more of a preventative measure than a countermeasure. Monitoring can be achieved by either instrumentation or by visual inspections (Hunt 2005).

Because the repair, or entire replacement, of a scour critical bridge is expensive and requires substantial effort on the part of the state department, early detection is preferred (Hunt 2005). Monitoring can occur after periods of high rainfall, flow, or flood events in addition to the required regularly-scheduled bridge inspection mandated by FHWA.



This research is focused on visual monitoring of a scour susceptible bridge. A visual inspection is required to provide basic bent geometry and scour conditions at a site before using the screening tool. Visual inspection, however, is not the only avenue for scour countermeasure. Therefore, a review of current scour monitoring measures was conducted.

In addition to visual monitoring, many departments have installed fixed instrumentation to monitor scour at bridge foundations (Hunt 2005). The most obvious benefit of installing fixed monitors is the continuous observation of scour. There are currently two types of fixed monitors: sonic fathometer and magnetic sliding collar monitors. Sonic fathometers, when attached to a pier, provide measurements at user-defined intervals of the bed material depth, which are collected into a database. From the database, the rise and fall of scour over time can be determined. Magnetic sliding collars, when fitted to a pile, fall with the stream bed during scour. Maximum scour depth, then, can be determined, but the changes in scour over time cannot be determined (Hunt 2005).

“Float out” devices can be buried at critical depths in the stream bed. When scour reaches this critical depth, the device is unearthed and then emits a warning (Hunt 2005). Presently, 32 states utilize scour monitoring systems covering a total of 120 bridge foundations, including pile foundations, spread footings, and drilled shafts (Yu and Zheng 2012).

Currently, new scour instrumentation is being developed. Tilt sensors, which monitor the structural movements of the bridge rather than the scour depth, are a relatively new product. McConnell and Cann (2011) reviewed the tilt sensor scour

monitoring system using a case study at the Indian River Inlet Bridge in Sussex County, Delaware. Scour exposes more pile length, thereby generating movement of the bridge assembly that the attached tilt sensors detect.

Monitors using mobile wireless technology, in conjunction with ground-penetrating radar (GPR), have also been researched in Seoul, South Korea. The scour depth, in addition to a geophysical assessment of the filling of scour holes via the GPR, can be sent to an offsite monitor, conducting safety evaluations instantaneously (Yu and Zheng 2012).

Computer programs specifically designed for screening bridge failure susceptibility after scour events are also used as part of an effective scour monitoring program. For example, a program for evaluating pile corrosion in marine environments has been developed (Zmeu 2012). While corrosion is not a direct effect of scour, as compared to the increased exposed pile length, the high water associated with scour events is favorable for pile degradation issues. Therefore, the effects of corrosion and marine borer presence are often included in scour investigations. The engineer may input estimated section losses into the computer program, which then evaluates the pile for localized buckling at critical sections, and global buckling of the entire pile. An output report is also produced by the program for documentation of the inspection (Zmeu 2012).

ALDOT presently uses an automated screening tool for the stability of steel bridge bents. This comprehensive tool checks for kick-out, plunging, buckling, pushover, and beam-column failures of piles and bents subject to scour. Because this steel tool has been well-received, the present research effort is concerned with the

development of a comparable automated timber screening tool for ALDOT's scour monitoring program.

## **2.4 Structural Analysis of Scour Critical Bridges**

Much research related to scour deals with the hydraulic component, i.e., it is mainly focused on describing the scour mechanism. Less research is concerned with the structural implications of scour (Bennett et al. 2009). The main structural failure types related to scour are as follows: pile plunging, pile buckling, pile corrosion, kick-out failure, and pushover failure (McConnell and Cann 2011). A useful stability screening tool, then, should at least evaluate all of these failure modes. The present timber screening tool, in addition to these failure modes, also includes a less-researched failure mode: upstream pile beam-column failure. Past analysis procedures for typical failure modes were reviewed in order to determine the best approach for the development of the timber screening tool.

### **2.4.1 Pushover Analysis of Scour Critical Bridges**

To establish the maximum tolerable displacement for tilt sensors at the Indian River Inlet Bridge (McConnell and Cann 2011), a finite element model was created to perform pushover analyses. Using Capacity Analysis Pushover Program (CAPP), a one-dimensional model of a single bent was created and then was laterally loaded in the direction of water flow. The lateral load was a combination of hydrostatic pressure due to water flow at the pier and wind acting on the bridge face, represented by a line load along the submerged pile portions. This load was much less than the load required to yield the concrete reinforcement, therefore it was expected that all piles would remain elastic.

Because bridge bents may act separately, it was assumed that modeling a single bent instead of an entire bridge would be sufficient. The concrete piles were modeled using beam elements connected by a rigid link serving as the pile cap. A pile batter could not be directly input into the finite element software so an increase in the pile moment of inertia was used to account for the increased stiffness due to pile batter. The soil profile at the Indian River Inlet Bridge consisted of a layer of clay overlaying a dense layer of sand. Soil properties needed for the program were estimated using like soil profiles rather than by direct soil testing. Soils were conservatively assumed to have no post-yield plastic behavior (McConnell and Cann 2011).

According to the current AASHTO limit states for bridges, the maximum tolerable displacement for strength is 13 mm (0.53 in.), while the maximum tolerable displacement for serviceability is 6 mm (0.23 in.) (McConnell and Cann 2011). The tilt sensors, then, would be installed such that displacement past this criterion would alert the engineers to potential failure. The sensors, however, can only indicate pushover failure, while neglecting the other major failure modes. In addition, the authors noted that, based on the finite element models, bents displacing more than 6 mm (0.23 in.) were, in fact, behaving inelastically (McConnell and Cann 2011). Therefore, for a quality pushover analysis, it was concluded that post-yield behavior of piles should be included.

Another bent pushover analysis was completed for Kansas Bridge 45 utilizing the Group Equivalent Pile (GEP) method (Bennett et al. 2009). Nonlinear behavior of both the piles and soil were included in the analysis. The soil profile was modeled using nonlinear springs at the base of the piles. Instead of modeling the entire pile group, an

“equivalent” pile which represented the entire group’s behavior was used. This was accomplished by using a pile with an unchanged cross-sectional area, but with an increased moment of inertia equal to the sum of the entire pile group. This pile was then loaded with a fraction of the lateral load on the entire pile group. The behavior of the entire pile group was then extrapolated from the single equivalent pile pushover analysis using a constant referred to as a “p-multiplier” (Bennett et al. 2009).

#### **2.4.2 Computer Modeling Approaches for Scour Critical Bridges**

It has been proposed that a specific computer model for a scour critical bridge is an effective and accurate monitoring approach. Yu and Zheng propose a model that can be continuously updated based on on-site sensor measurements of scour (2012). For the case study, SAP2000 (a commonly-used structural modeling software) was used to create a model of the No. 127.9 Bridge located on U.S. Highway 61. Pile bents were represented by a single pile connected by frame elements. The soil was represented by springs, analogous to a beam on a Winkler foundation, where the removal of springs imitated scour (Yu and Zheng 2012).

Lin et al. took a different approach to the modeling: combining structural and foundation analysis software to produce an integrated bridge model (2012). Playing to each software’s strength, *FB-MultiPier* was used to complete a nonlinear substructure analysis while *STAAD Pro* was used to complete a nonlinear superstructure analysis. The *FB-MultiPier* results were converted to a stiffness matrix that could describe spring supports for the *STAAD Pro* model. Loads were then applied to the integrated *STAAD Pro* bridge model, producing pile cap loads which could be integrated back into the *FB-MultiPier* model. After iteration, the two models reached equilibrium. To demonstrate

the modeling approach for scour critical bridges, the Kansas Bridge 45 was modeled using the integrated method, then buckling capacities and lateral responses after scour were determined (Lin et al. 2012).

While both Yu and Zheng and Lin et al. methods are accurate for the modeling of scour critical bridges, the methods are both time- and labor-consuming. Lin et al. especially made an effort to use software familiar to bridge design engineers so that the method could have practical applications. This method could be very beneficial for high-profile or vital scour critical bridges, however, due to the large number of bridges under ALDOT supervision requiring monitoring, computer models completed on a per-bridge basis is not a feasible state-wide scour monitoring practice. A screening tool, covering a wide range of bridges, is more valuable to ALDOT.

#### **2.4.3 Steel Screening Tool**

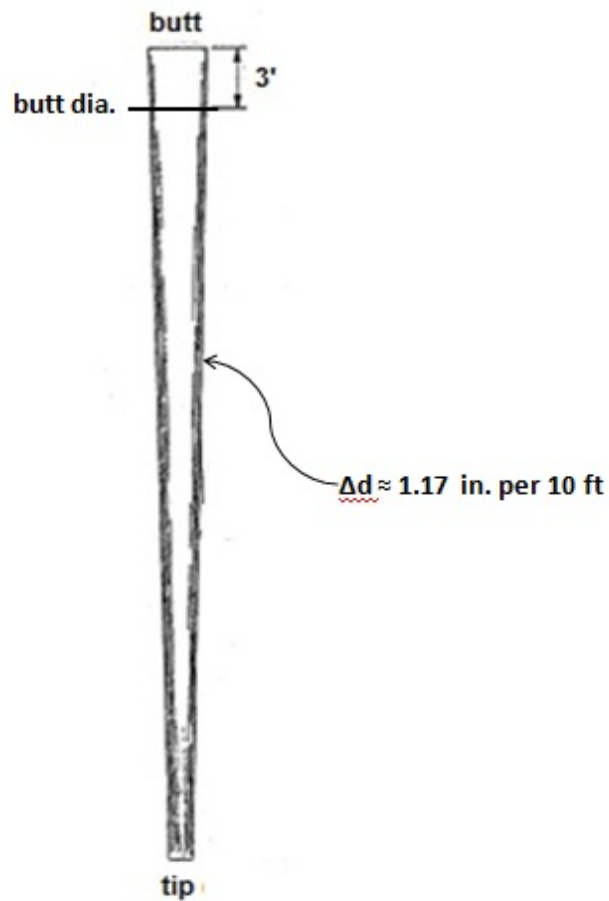
In order to develop a comparable timber stability screening tool, the previous steel screening tool analyses were used as a framework. While pushover analyses separate from the steel tool were necessary due to considerable differences in geometry and material properties, the equations for kick-out, plunging, buckling, and beam-column needed only to be tailored to the new tool. Discussion of the specific equations, and their tailoring, is presented in Chapter 4.

#### **2.5 Material Properties of Timber Piles**

The previous screening tool was concerned with bridges constructed using steel pile bents. Therefore, to develop the present tool, it was necessary to conduct investigations of timber as a construction material. Timber piles, in addition to having different material properties, have inherent geometric differences from steel piles, most

notably the timber pile taper. Adjustments were made to the previous screening tool analyses to account for these differences.

A schematic drawing of a typical timber pile is shown in Figure 2.2. Note the significant pile taper, or change in diameter, that is characteristic of timber piles. Timber piles must be tapered in order to drive them into soil. For the pile shown, the taper corresponds to a 1.17 inch decrease in diameter per 10 feet of pile. The pile is from a set of timber utility poles investigated by P.S. Quintero (1980) in a region of Birmingham, Alabama hit by a severe tornado in 1977. Note the designation that the butt diameter value is typically taken as the diameter 3 feet from the top of the pile.



**Figure 2.2 Typical Timber Pile (Quintero 1980)**

Typical limiting dimensions of common timber piles are summarized below in Table 2.2, adapted from R.D. Chellis (1961).

**Table 2.2 Typical Limiting Dimensions of Piles, Inches (Chellis 1961)**

Place measured	Timber Species										
	Southern pine and Douglas fir					Oak, cypress, and chestnut			Cedar		
	< 40 ft long	40-50 ft long	51-70 ft long	71-90 ft long	> 90 ft long	< 30 ft long	30-60 ft long	> 60 ft long	< 30 ft long	30-60 ft long	> 60 ft long
<b>ASTM, ASA, and CESA Class A piles for railway bridges</b>											
Butt* (min.)	14	14	14	14	14	14	14	14	14	14	14
Butt* (max.)	18	18	18	20	20	18	18	18	22	22	22
Tip (min.)	10	9	8	7	6	10	9	8	10	9	8
<b>ASTM, ASA, and CESA Class B piles for highway bridges</b>											
Butt* (min.)	12	12	13	13	13	12	13	13	12	13	13
Butt* (max.)	20	20	20	20	20	18	20	20	22	22	22
Tip (min.)	8	7	7	6	5	8	8	7	8	8	7
<b>ASTM, ASA, and CESA Class C piles for second-class construction</b>											
Butt* (min.)	12	12	12	12	12	12	12	12	12	12	12
Butt* (max.)	20	20	20	20	20	20	20	20	22	22	22
Tip (min.)	8	6	6	6	5	8	8	6	8	8	7

\* Butt dimensions taken 8 ft from end.

It should be noted that alternate wetting and drying of piles that occurs near the water line for timber piles supporting bridges over water subject the piles to wood rot, fungus growth, and marine animal or insect attack. The severity of the wood decay due



to these factors can be greatly reduced by chemical treatment of the wood piles, but such treatment will not entirely prevent decay. This is especially critical in situations where the pile is exposed to the air and alternately to wet and dry periods, as is typical for timber bridges over water (Ramey et al. 2011). Rot or insect attack will result in the loss of cross section, therefore the loss of section modulus, which is required for bending capacity.

The approximate modulus of elasticity (E), crushing strength, and bending strengths of timber piles most commonly used in Alabama are shown in Table 2.3. The values are extracted from Chellis (1961).

**Table 2.3 Approximate Elastic Modulus and Strengths of Woods Commonly Used for Timber Piles in Alabama (Chellis 1961)**

Wood Species	Green (Untreated)			Air-Seasoned (Untreated)		
	Elastic Modulus, E (psi)	Crushing Strength (psi)	Bending Strength (psi)	Elastic Modulus, E (psi)	Crushing Strength (psi)	Bending Strength (psi)
Pine-Longleaf	1,600,000	4,300	8,700	1,990,000	8,440	14,700
Pine – Shortleaf	1,390,000	3,430	7,300	1,760,000	7,070	12,800
Douglas Fir	1,550,000	3,890	7,600	1,920,000	7,420	11,700
Southern Cypress	1,180,000	3,580	6,600	1,440,000	6,360	10,600
Oak - White	1,200,000	3,520	8,100	1,620,000	7,040	13,900

In timber design, nominal strength capacities, such as those shown in Table 2.3, are adjusted for the effect of load, environment, and construction. Shaeffer (1980) states that when the duration of loading is known, the allowable stresses for timber may be increased by the following factors:

**Table 2.4 Load Duration Modification Factors for Timber (Schaeffer 1980)**

<b>Load Duration</b>	<b>Modification Factor</b>
Two Months (Snow)	1.15
Seven Days	1.25
Wind or Earthquake	1.33
Impact	2.00

Based on these values, it was assumed for extreme scour that an allowable stress modification factor of 1.30 is appropriate. Schaeffer states that the modulus of elasticity values are not subject to such modifications. Based on common timber species and with application of the load duration modification factor, the following material properties were used in the screening tool:

**Table 2.5 Timber Pile Material Properties Used in Screening Tool**

<b>Material Property</b>	<b>Value used in ST</b>
Young's Modulus, E (ksi)	1,800
Crushing Strength (ksi)	7.00
Bending Strength (ksi)	12.0

In order to determine buckling length, the end conditions of the pile must be estimated. To help gain a sense of depth of pile embedment required to achieve a “fixed” end condition for checking bent pile buckling after a major scour event, timber utility pole embedment specifications of the Alabama Power Company were examined. Table 2.6 shows some select geometrical properties of ground-embedded timber utility poles. This table was adapted from select circa-1980 tables of the Alabama Power Company Specifications and Standards (Quintero 1980). Note that the length of pile above ground is designated as  $L_{ag}$  and the embedment length below ground as  $L_{bg}$ . The symbol “D” designates the diameter and “S” the section modulus.

**Table 2.6 Geometric Properties of Select Timber Utility Poles\* (Quintero 1980)**

Pole	Pile Length, L (ft)	Pile Embedment, L <sub>bg</sub> (ft)	L <sub>ag</sub> /L	Pile Height, L <sub>ag</sub> (ft)	D <sub>base</sub> (in)	D <sub>top</sub> (in)	D <sub>avg</sub> (in)	S <sub>base</sub> (in <sup>3</sup> )
30/7	30	5.5	0.183	24.5	7.54	4.78	6.16	42
30/6					8.01	5.41	6.71	50
30/5					8.81	6.05	7.43	67
35/6	35	6.0	0.171	29.0	8.59	5.41	7.00	62
35/5					9.23	6.05	7.64	77
35/4					10.0	6.68	8.36	99
40/6	40	6.0	0.150	34.0	9.07	5.41	7.24	73
40/5					9.87	6.05	7.96	94
40/4					10.7	6.68	8.67	119
45/6	45	6.5	0.144	38.5	9.50	5.41	7.46	84
45/4					11.1	6.68	8.88	134
45/2					12.8	7.96	10.4	207
50/4	50	7.0	0.140	43.0	11.5	6.68	9.10	150
50/3					12.3	7.32	9.81	183

**\*From Alabama Power Company Distribution Standard Drawing A-194823**

Note that the diameter, and therefore section modulus, is the largest at the base for timber utility poles since they are embedded with the diameter increasing from top to bottom. Timber bridge piles, however, are embedded with a decreasing taper. For piles, the larger diameter is at the cap because high axial loads and smaller lateral loads are typical for bridge design. However, the depth of embedment of utility poles gives an approximation of percentage embedment required to develop a reasonable moment resistant fixity at the ground line. This is important because for an unbraced bent, piles require a significant fixity at the ground for stability.

During the development of the previous steel stability screening tool, soil-pile interaction was also considered. According to Hughes et al. (2007), the soil subgrade modulus does not have any real effect on the deflection of steel piles. Pile “fixity” was determined to occur at 1.5 meters (or 5 feet) of pile embedment (Hughes et al. 2007).

## **2.6 Review of Visual Studio and Visual Basic Code Writing (VBA)**

While the author already had some experience in Visual Basic (VBA) code writing, more education was required for the development of the automated timber screening tool. A Visual Studio 2005 guide by Halvorson (2006), including example problems and techniques, was consulted in addition to the previous steel stability screening tool. Its code was often used as a learning tool or as a base template for the timber screening tool.

**CHAPTER 3**

**SCOUR MONITORING OF COUNTY BRIDGES  
SUPPORTED ON TIMBER PILE BENTS**

**3.1 General**

The need for an automated screening tool to evaluate the stability of bridges subject to scour was established in Chapter 2. While a steel stability screening tool has been produced by Auburn University personnel and is currently in use by ALDOT personnel, the bridge inventory does not consist solely of steel-pile-supported bridges. In the past, two-lane highway timber-bent-supported bridges were commonly used by counties, as well as by some state departments of transportation, in the United States. A typical timber pile bent in Alabama is shown in Figure 3.1. Note the cross-bracing that is typical for timber bents.



**Figure 3.1 Typical Timber Pile Bents (provided by ALDOT)**

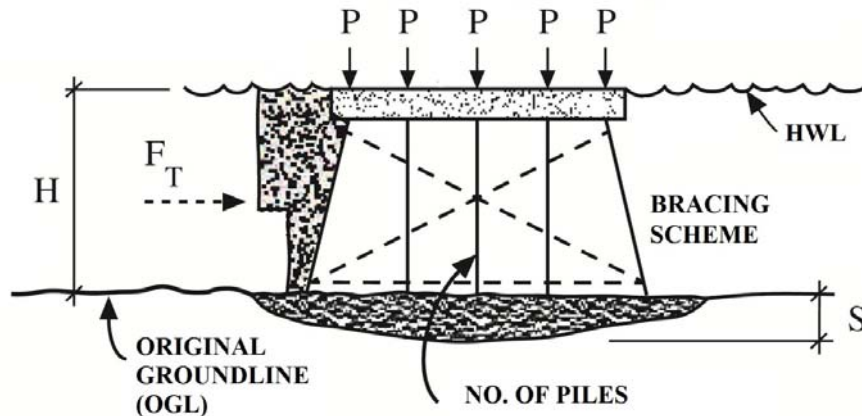
Some of these bridges are still in existence, in addition to bridges that have had their timber superstructure replaced with combinations of steel or concrete girders with a concrete deck, while continuing to use the original timber pile bent substructure.

The volume of timber-pile-supported bridges under ALDOT jurisdiction is extensive. Therefore an automated timber screening tool comparable to its current steel screening tool was requested by ALDOT personnel. The tool was envisioned as using visual inspection data to perform structural stability analyses. These analyses should indicate whether the bridge is scour critical. In addition, the scour value at which failure becomes imminent, also called the critical scour depth, should also be determined by the tool. A printable report was also requested for documentation in the National Bridge Inventory System (NBIS).

It is important to stress that the tool is meant only “screen” to scour susceptible bents and therefore generic assumptions must be made to cover a wide range of timber bridges. All geometric and material assumptions made by the screening tool are identified in this chapter. In order to effectively use the tool, an understanding of these assumptions is required. ALDOT performed a survey of timber structures to provide a realistic range of bent configurations for the purpose of creating a generic stability screening tool. The parameters needed for assessment and the resulting values are discussed in this chapter. In addition, the timber material property assumptions made in the development of the screening tool are outlined. The computation of the debris raft forces assumed by the screening tool is also discussed.

### 3.2 Bridge Parameter Values Needed to Assess Bridge Stability

In order to assess the adequacy of a bridge during a major flood or scour event, bridge engineers must know vital information pertaining to the bridge superstructure and live loads acting thereon, such as support pile bent geometry and member sizes; pile driving and support soil conditions; river or stream high water level, flow velocity, level of possible scour. The most basic information needed is presented graphically in Figure 3.2. The parameters include the following: the bent height,  $H$ ; the lateral force acting on the bent,  $F_t$ ; the location of the high water line, HWL; the gravity loads,  $P$ ; the diameter of the piles,  $\Phi$ ; the number of piles; the bracing configuration; the elevation of the original ground line, OGL; and the maximum depth of scour,  $S$ .



**Figure 3.2 Transverse Section of a Typical Timber Bridge with Information Needed to Assess Adequacy During an Extreme Scour Event**

### 3.3 Possible Failure Modes of Timber Pile Bents

Based on past experience in screening ALDOT bridges as indicated in the Phase I through III Reports (Ramey et al. 2004; 2006; 2008), possible failure modes of bridge pile bents during extreme scour events are as follows:

- (1) Kick-out of the pile bent due to zero or negligible embedment after scour;

- (2) Plunging due to soil failure;
- (3) Buckling failure in either the longitudinal or transverse direction;
- (4) Bent pushover failure due to the combined superstructure gravity and lateral debris raft loadings;
- (5) Beam-column failure of the upstream pile due to the combined lateral debris raft and axial gravity loadings.

It should be noted that crushing of a pile during an extreme scour event is not a viable failure mode for timber piles. Recalling that 7.0 ksi is assumed to be the crushing stress for a timber pile, even for the smallest considered diameter (6 inches) the minimum crushing load, as determined in the following equation, is 198 kips, which is much greater than the maximum pile applied load considered in the screening tool of 60 kips.

$$P_{crushing} = \sigma_{crushing} \cdot Area = 7.0 \text{ ksi} \left( \frac{\pi 6^2}{4} \right) = 198^k \gg P_{max\ applied} = 60^k$$

In addition,  $P_{max\ applied}$  and  $P_{crushing}$  of the piles are unaffected by a scour event, therefore crushing will not be affected by an extreme scour event.

Buckling, plunging, bent pushover, kick-out, and beam-column failures are the only realistic catastrophic failure modes, and therefore are the only five modes of failure that require consideration. Each of these possible failure modes and the manner for checking each of them is discussed in detail in the following chapter.

### 3.4 Typical Value Ranges of Alabama County Bridges

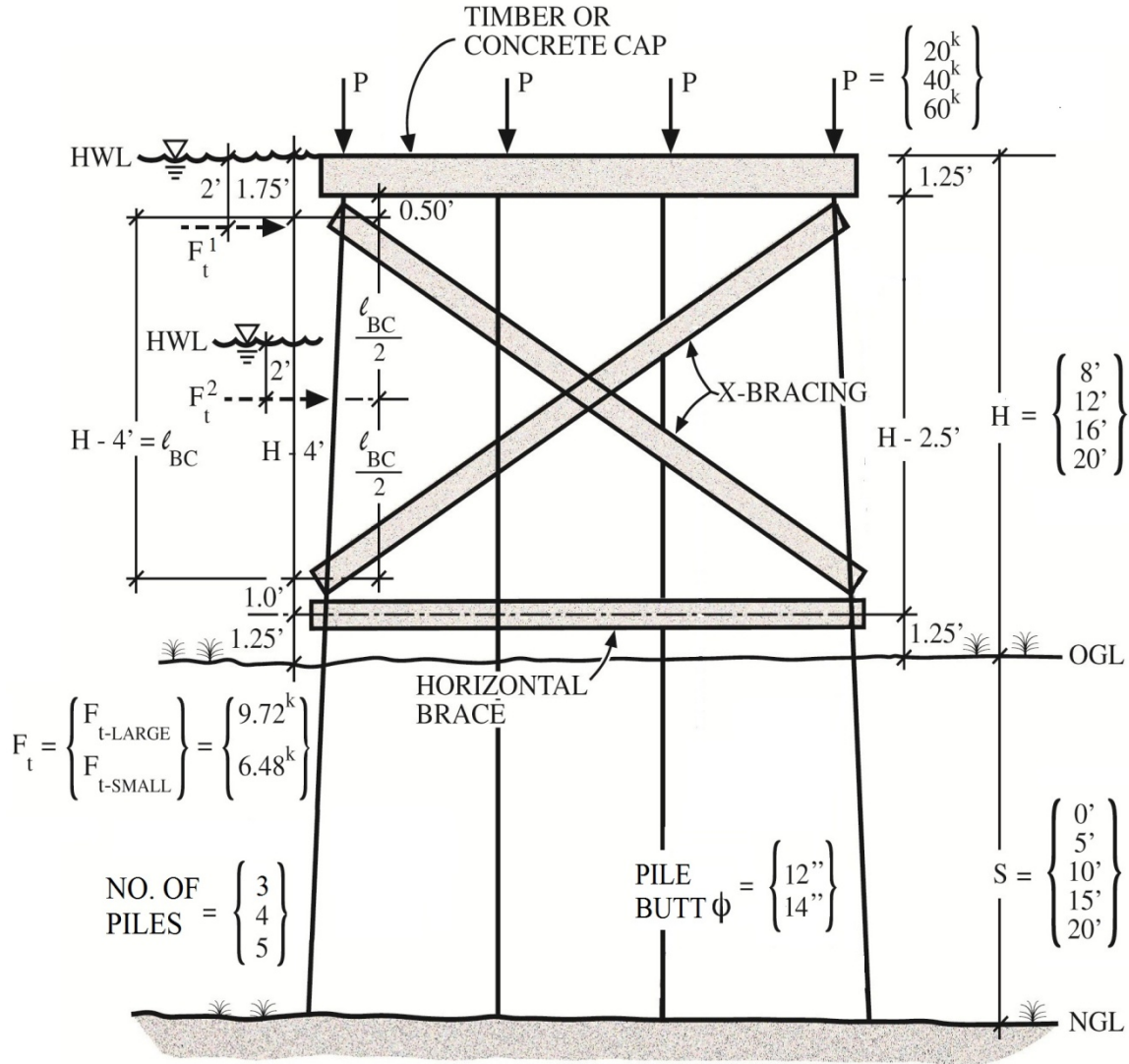
After completing a survey of timber bridges, ALDOT personnel determined that the following typical values and ranges of values were appropriate for the screening tool. First, hydrologic data indicated scour depths of 5, 10, 15, and 20 feet are expected. The average estimated high water line is 10 feet from the ground line. A



review of typical bent geometries yielded bent height ranges from 6 to 22 feet with an average of a 10 foot bent height. Therefore, bent heights of 8, 12, 16, and 20 feet were considered in the screening tool. The number of piles per bent was found to be 3, 4, or 5, with 4 piles per bent being the most common configuration. Piles are spaced at distances ranging from 5.3 feet to 7.8 feet, therefore an average value of 6.5 feet was assumed for this effort. Piles, if battered, use a 1:12 batter. Both one-story and two-story bracing was observed for timber pile bents; however, this screening tool only considers one-story bracing. Note that because two-story bracing is stiffer than one-story bracing, this limitation is conservative.

Pile driving data was also investigated. Pile lengths varied from 15 to 40 feet with an average of 31 feet. Pile tip diameters were 7, 9, and 10 inches, while pile butt diameters were 12, 13, and 14 inches. The screening tool considers 12 and 14 inch diameter butts. Probable final driving resistances ranged from 2.5 to 8 blows per inch (bpi) with 4 bpi being the average. Most piles were driven using a drop hammer with 10,000 to 15,000 ft-lb of driving energy. Embedment varied from 9 to 32 feet with an average of 22 feet.

It is also necessary that superstructure characteristics be known to determine loading and end conditions. Bridge spans lengths ranged from 15 to 26 feet. Bridge caps were either timber caps ranging from 10 in. by 10 in. to 12 in. by 14 in., or concrete caps ranging from 12 in. by 16 in. to 24 in. by 24 in. Pile loads were determined to vary substantially, but all were assumed less than 60 kips. Roadways were considered one-way for all widths less than 18 feet. Figure 3.3 summarizes the value ranges considered, along with the geometric assumptions used in the screening tool.



**Figure 3.3 Alabama County Timber Pile Bent  
Ranges of Critical Assessment Parameters**

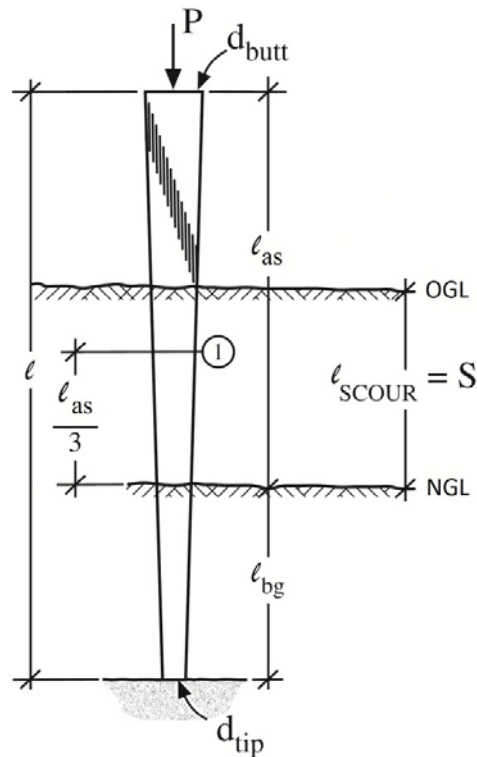
### 3.5 Material Assumptions Used in Screening Tool

As discussed in the literature review, material assumptions were needed for the screening tool. To review: based on common timber species and with application of the load duration modification factor, the material properties summarized in Table 3.1 were used in the screening tool.

**Table 3.1 Timber Pile Material Properties Used in Screening Tool**

Material Property	Value used in ST
Young's Modulus, E (ksi)	1,800
Crushing Strength (ksi)	7.00
Bending Strength (ksi)	12.0

Due to pile taper, an effective section must be used to determine section properties of a particular pile. For the screening tool, the section corresponding to two-thirds of the pile height after scour measured from the top of the pile was deemed the appropriate effective section as shown in Figure 3.4 below. In this figure, the length of scour is designated as  $S$ , the length of embedment below ground after the scour event is  $l_{bg}$ , and the length of pile above ground after the scour event is  $l_{as}$ .



**Figure 3.4 Effective Section of Embedded Timber Pile (Ramey et al. 2011)**

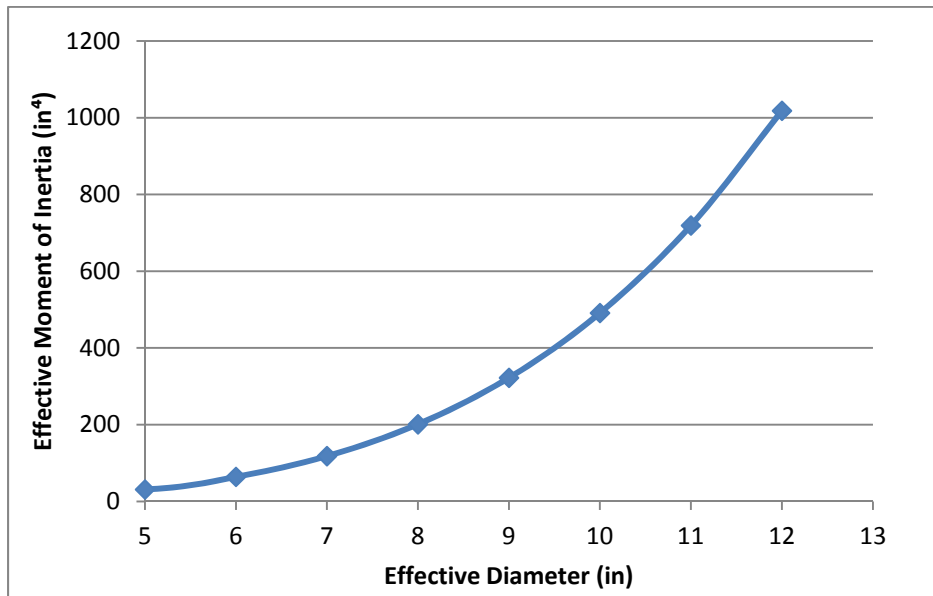
The moment of inertia for a circular pile was determined as follows:

$$I_{eff} = \frac{\pi d_{eff}^4}{64}, \quad (3-1)$$

where  $d_{eff}$  is the diameter of the pile corresponding to two-thirds of the pile height measured from the pile cap after scour. The effective section modulus for bending was determined to be the following:

$$S_{eff} = \frac{\pi d_{eff}^3}{32} \quad (3-2)$$

A plot illustrating the exponential increase in effective moment of inertia for timber piles with an increase in the pile effective diameter is shown in Figure 3.5. Note that the timber pile buckling load consequently exhibits this same dramatic increase with increasing pile effective diameter.



**Figure 3.5 Variation of Pile Effective Moment of Inertia versus Pile Diameter**

For example, for a 50 foot pile with a diameter taper of 1.2 inches per 10 feet, the following effective section properties shown in Table 3.2 would be used by the screening tool:

**Table 3.2 Typical Effective Section Properties for Common Pile Sizes**

$d_{\text{butt}}$ (in)	$d_{\text{tip}}$ (in)	$d_{\text{eff}}$ (in)	$I_{\text{eff}}$ (in <sup>4</sup> )	E (ksi)	$EI_{\text{eff}}$ (k-in <sup>2</sup> )
12	6	8.8	294	1,800	529,200
14	8	10.8	668	1,800	1,202,000

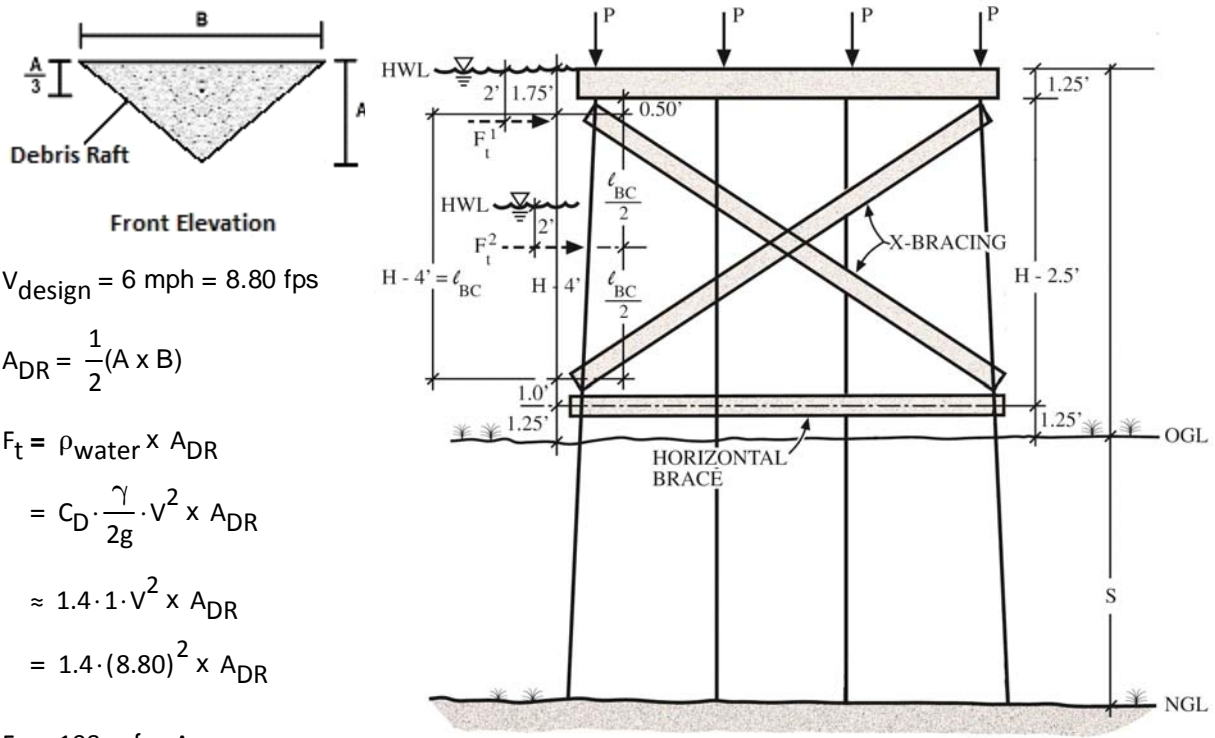
Notice that the effective moment of inertia for the 14 inch pile diameter is more than twice that of the 12 inch pile. A pile taper is 0.12 inches per foot is assumed in the screening tool.

### 3.6 Debris Raft Consideration for Small Span Bridges

In addition to conducting background research of timber as a construction material for bridge piles, it was necessary to reevaluate the debris raft calculation included in the previous screening tool for smaller span bridges. In the previous steel screening tool, a single design raft force of 12.15 kips was used (Donnee et al. 2008). This lateral force corresponds to the size of debris raft that could accumulate on a bridge bent during flood events. Steel bridges, however, are typically longer-span bridges as compared to low-volume timber county bridges.

The same process used to calculate the design lateral debris raft force in the steel screening tool was followed to calculate the timber screening tool design lateral forces. Figure 3.6 illustrates this calculation. Note that two raft forces, one corresponding to shorter bridge spans (less than 25 feet) and one corresponding to longer spans (25 to 36 feet) were employed by the screening tool. The inclusion of the smaller raft force for shorter spans makes the screening tool more realistic for smaller

span bridges. Without it, these small span bridges would be evaluated using an overly conservative debris raft force. The raft force values are 6.48 and 9.72 kips for the small and large rafts, respectively. After applying a factor of safety of 1.33, these forces are amplified to 8.62 and 12.93 kips.



$$V_{\text{design}} = 6 \text{ mph} = 8.80 \text{ fps}$$

$$A_{\text{DR}} = \frac{1}{2}(A \times B)$$

$$\begin{aligned} F_t &= \rho_{\text{water}} \times A_{\text{DR}} \\ &= C_D \cdot \frac{\gamma}{2g} \cdot V^2 \times A_{\text{DR}} \\ &\approx 1.4 \cdot 1 \cdot V^2 \times A_{\text{DR}} \\ &= 1.4 \cdot (8.80)^2 \times A_{\text{DR}} \end{aligned}$$

$$F_t = 108 \text{ psf} \times A_{\text{DR}}$$

**Bridge Span Lengths: 15 ft ≤ L ≤ 36 ft**

$$\text{If } 15 \text{ ft} \leq L < 25 \text{ ft use } B = 20 \text{ ft and } A = 6 \text{ ft} \rightarrow A_{\text{DR}} = 60 \text{ ft}^2$$

$$\text{If } 25 \text{ ft} \leq L \leq 36 \text{ ft use } B = 30 \text{ ft and } A = 6 \text{ ft} \rightarrow A_{\text{DR}} = 90 \text{ ft}^2$$

Therefore,

$$F_t^{\text{smaller}} = 108 \text{ psf} \times 60 \text{ ft}^2 = 6,480 \text{ lbs} = 6.48 \text{ kips}$$

$$F_t^{\text{larger}} = 108 \text{ psf} \times 90 \text{ ft}^2 = 9,720 \text{ lbs} = 9.72 \text{ kips}$$

**Using a FS = 1.33**

$$\left( F_t^{\text{smaller}} \right)_{\text{Design}} = \text{FS} \times F_t = 1.33 \times 6.48 \text{ kips} = \mathbf{8.62 \text{ kips}}$$

$$\left( F_t^{\text{larger}} \right)_{\text{Design}} = \text{FS} \times F_t = 1.33 \times 9.72 \text{ kips} = \mathbf{12.93 \text{ kips}}$$

**Application of Pushover Force through Centroid of Debris Raft:**

$F_t^1$  acting as shown above for **bent pushover analysis**, while

$F_t^2$  acting as shown above is used in check of upstream pile as a **beam column**

**Figure 3.6 Debris Raft Force Calculation for Small Span Bridges**

## CHAPTER 4

### FAILURE MODES FOR TIMBER BENTS SUBJECT TO SCOUR

#### 4.1 General

As indicated in Chapter 3, the five failure modes considered for timber pile bents during an extreme scour event are as follows:

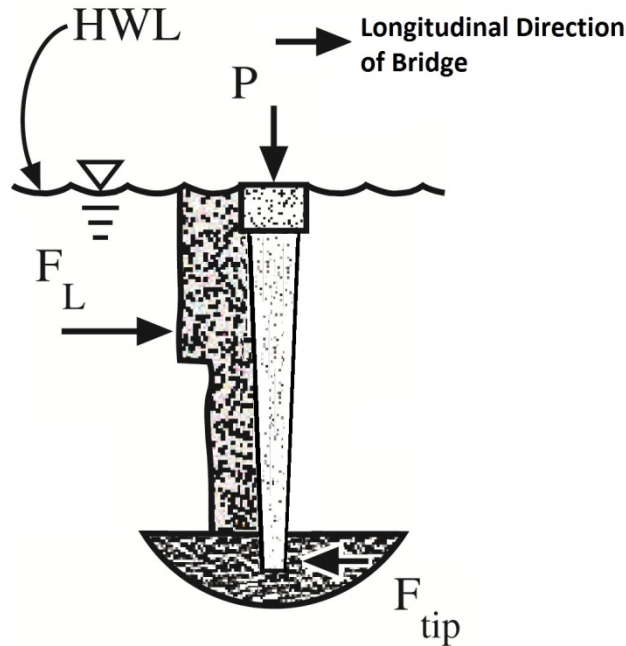
- (1) Kick-out of the pile bent due to zero or negligible embedment after scour;
- (2) Plunging due to soil failure;
- (3) Buckling failure in either the longitudinal or transverse direction;
- (4) Bent pushover failure due to the combined superstructure gravity loading and lateral debris raft load;
- (5) Beam-column failure of the upstream pile due to the combined lateral debris raft load and axial gravity loading.

The theoretical analysis procedures for each of these failure modes are outlined in this chapter.

#### 4.2 Kick-out Failure

Lateral forces created by water flow and debris rafts, shown as  $F_L$  in Figure 4.1, induce a lateral force at the tip of the pile, shown as  $F_{tip}$ . “Kick-out” failure will occur if the passive earth pressures of the soil at the tip cannot overcome the force induced at the tip (Ramey et al. 2006).





**Figure 4.1 Pile Tip Kick-Out Failure**

Because the passive earth pressure resistance is provided by the pile embedment, excessive scour will reduce kick-out capacity. In the preceding steel screening tool, it was determined that for a remaining embedment of less than 3 feet, kick-out was possible (Donnee et al. 2008). This minimum value included a factor of safety of 1.50. However, this assumption cannot necessarily be made for timber piles due to differences in drag coefficients. The drag force on a pile is proportional to the pile drag coefficient; a larger coefficient corresponds to a larger drag force that may develop to kick-out the pile. For a steel pile, a drag coefficient of 2.0 was used, whereas for a timber pile, a drag coefficient of 1.2 is more correct. Therefore, a timber pile would develop 40 percent less drag force.

Because of the differences in drag coefficients, it was assumed that for 40 percent less drag force, 40 percent less minimum embedment would be required for a

timber pile to prevent kick-out. Therefore, the minimum length after scour required for the timber screening tool can be computed as

$$l_{as}^{minimum} = 3.0 \text{ ft} \times 0.6 = 1.8 \text{ ft}.$$

Since embedment lengths of piles will be estimated, the minimum embedment length should be rounded up to 2.5 feet to account for error. Accordingly,

$$l_{as}^{allowable \ minimum} = 2.5 \text{ ft}.$$

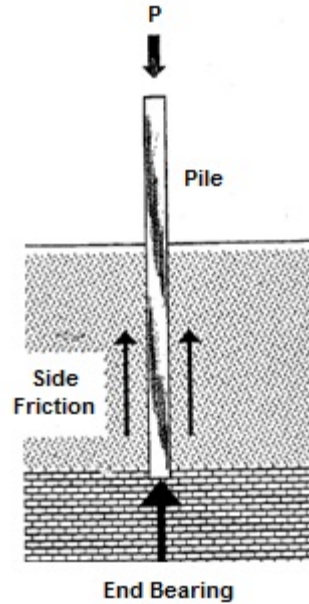
For an embedment less than 2.5 feet, kick-out failure is imminent. Corrective action such as the placement of riprap around pile bases should be taken immediately.

In order to ensure continual protection against kick-out during subsequent flood events, it is recommended that preventative measures be taken for any embedment length less than 5 feet, i.e.

$$l_{as} \leq 5.0 \text{ ft} \rightarrow \textit{Take Preventative Action Against Kick - out}$$

### **4.3 Pile Plunging by Soil Failure**

Excessive scour can alter a pile's soil profile and can result in failure by plunging. Plunging failure occurs when pile bearing and side friction capacity do not provide enough resistance to support axial loads and the pile "plunges" into the soil. The axial resistance of a pile as provided by side friction and end bearing is illustrated in Figure 4.2. The magnitudes of these load-resisting forces are functions of both geometry and surface characteristics of the pile, as well as soil properties.



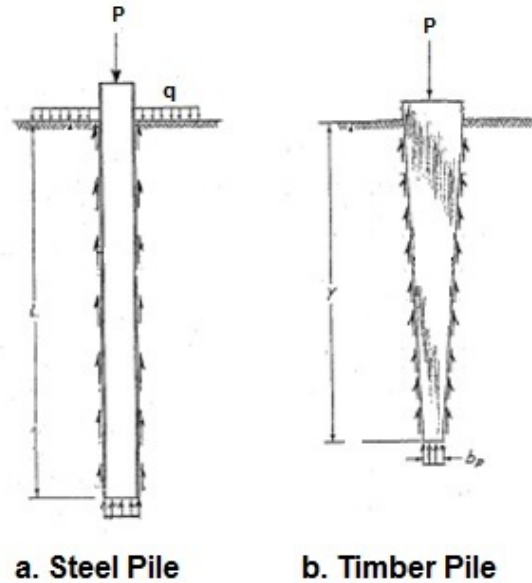
**Figure 4.2 Pile Axial Resistance**

It should be noted that the ability of the soil to support the load transmitted by the pile generally determines the adequacy of pile foundations, rather than the stresses on the pile itself. The permissible working stresses for piles of any material are seldom fully utilized in a bent. For example, if the maximum load  $P_{max} = 60^k$  is applied to a timber pile and the minimum pile tip diameter is 6 in., the maximum stress is 2.12 ksi, determined as follows:

$$\sigma_{axial}^{pile} = \frac{60^k}{\frac{\pi \cdot 6^2}{4}} = \frac{60^k}{28.3 \text{ in}^2} = 2.12 \text{ ksi}$$

Even if the full P-load is carried down to the pile tip, disregarding soil properties, the pile would be considered safe because its maximum stress is quite low.

It should also be noted that because of their taper, timber piles develop significant wedge action and reactive side pressures from the soil and thus induce large skin friction resistance forces. Relative to steel piles, timber piles act more like friction piles, as illustrated in Figure 4.3.



**Figure 4.3 Elevation Schematics of Timber and Steel Wide-Flange Piles**

The major variables affecting the axial resistance of a timber pile after scour are as follows:

- (1) The driving resistance at the end of pile driving;
- (2) The energy of the hammer used to drive the pile;
- (3) The soil profile surrounding the pile;
- (4) The amount and nature of scour that has occurred.

Information on soil properties at each specific bent is typically inadequate or incomplete. However, the driving resistance (blows per foot of penetration during pile driving) of the pile at the time of construction provides a crude, but reasonably reliable indication of soil resistance that has been mobilized. Common required final driving resistance ranges are shown in Table 4.1 (Bowles 1968). Often, piles may be driven to a commonly accepted final resistance without detailed recording of the blow counts. In such a case, a conservative, or low, estimated final driving resistance is recommended for use in the screening tool.

**Table 4.1 Common Required Final Driving Resistance Ranges (Bowles 1968)**

<b>Pile Material</b>	<b>Final Driving Resistance (blows per inch)</b>
Timber	4-5
Concrete	6-8
Steel	12-15

The energy of the hammer, in kip-feet, is expressed by the rated energy, which is equal to the weight of the ram (kips) multiplied by the height of the drop (feet); the values are often taken from a driving log. For the screening tool, the driving system used for installing the pile must be known or estimated. The rated energy must then be reduced to account for losses due to inefficiency, such as inherent friction losses, in the driving system. Piles for small bridges in Alabama have typically been driven by one of several types of hammers with estimated efficiencies that are summarized below in Table 4.2.

**Table 4.2 Estimated Hammer Efficiencies**

<b>Hammer Type</b>	<b>Estimated Efficiency</b>
Single Acting Air/Steam	67%
Double Acting Air/Steam	50%
Diesel	80%
Drop Hammer	50%

Note that drop hammers can vary widely and are not currently used on ALDOT projects. However, these have been used on many older bridges. Note that with very high drop heights (more than 5 feet) and low ram weights, the energy losses for a drop hammer can result in an efficiency significantly lower than 50%.

The soil profile can be used to determine whether piles are acting primarily as friction or end-bearing piles. Dense sand strata, hard clays or marl, or rock underlying

soft alluvial soil are likely to represent a case where end bearing is the dominant mode of resistance. Similarly, pile driving records that show relatively low blow counts followed by a dramatic increase in the driving resistance at some depth just prior to the end of driving would suggest a strong bearing layer. Friction piles would likely be used where there are deep clay strata with no hard bearing layer; in such cases the pile embedded lengths would likely be great.

Reduction in capacity is also related to the nature of the scour event. Local scour, which is confined to a small area around the pile, will reduce the amount of soil in contact with the sides of the pile and will thereby reduce the side friction. However, local scour does not have a major effect on the magnitude of the confining pressures on the soil at the tip and therefore does not significantly reduce the end-bearing capacity. General scour of the entire streambed around the bent would likely reduce the confining pressures in the ground at the pile tip and could therefore reduce the end bearing resistance as well as the side-shearing resistance.

Correlations of pile driving resistance to axial static pile capacity have been developed using a number of simple pile driving formulas. The current AASHTO specifications (2007) recognize and allow the use of the Modified Gates formula when insufficient information is available to create a wave equation model. For timber bridges, which are often older structures without ample reliable data, the Modified Gates formula is well suited. The equation, shown as Equation 4-1, correlates pile capacity with hammer driving energy and driving resistance at the end of driving (EOD) for a given pile hammer energy.

$$P_{Nominal} = 0.875 E^{0.5} \text{Log} (10N_b) - 50 \quad (4-1)$$

$P$  is defined as the nominal resistance in tons,  $E$  the energy produced by the hammer per blow in foot-pounds, and  $N_b$  the blow count in blows per inch. Applying a factor of safety of 1.25 for plunging, the allowable resistance is

$$P_{Allowable} = \frac{P_{Nominal}}{1.25} \quad (4-2)$$

For the screening tool, the axial resistance prior to scour is assumed to be represented by one of two cases: (a) predominantly end-bearing action in which 75% of the axial resistance of the pile would be provided by end bearing and 25% by side shear or (b) predominantly friction resistance in which 25% of the axial resistance is provided by end bearing and 75% by side shear. The latter case is more susceptible to scour since removal of the soil has a greater effect on side shear than on end bearing, as previously discussed.

The proportion side shearing resistance lost is assumed to be proportional to the percent loss of embedment after scour. In a homogenous soil profile with general scour of the streambed (as opposed to localized scour) it is conceivable that the reduction in side-shearing resistance could be greater than the proportional percentage loss of embedment, due to the reduction in confining stress associated with scour. However, it is anticipated that a significant proportion of the scour loss will usually be due to localized scour, which will not have a significant effect on confining pressure. It is also expected that, more commonly, side-shearing resistance actually increases with increasing depth, and therefore a linearly proportional reduction in side shear is conservative. In equation form, the percent loss of pile capacity in friction can be written as the following:

$$\%LOSS_{Friction} = \%Loss\ Embedment \quad (4-3)$$

In order to account for the reduction in confining stress at the pile tip associated with scour, the end-bearing resistance is reduced by an amount equal to half of the proportional loss of embedment due to scour. This reduction is realistic for piles bearing in cohesionless sand and conservative for cemented bearing strata that have significant cohesion. The following equation accounts for percent loss of pile capacity in end-bearing:

$$\%LOSS_{End-Bearing} = \frac{\%Loss\ Embedment}{2} \quad (4-4)$$

Using these capacity loss equations, the plunging capacity for timber piles can be expressed by the following equations:

$$P_{Friction} = P_{Allowable} \cdot [1 - (0.75 \cdot \%LOSS_{Friction} + 0.25 \cdot \%LOSS_{End-Bearing})] \quad (4-5)$$

$$P_{End-Bearing} = P_{Allowable} \cdot [1 - (0.25 \cdot \%LOSS_{Friction} + 0.75 \cdot \%LOSS_{End-Bearing})] \quad (4-6)$$

Equation 4-5 and Equation 4-6 were applied repeatedly for a multitude of driving hammer energies, driving resistances, and scour depths; the results are presented in Table 4.3. Note that interpolation between values in the table is permitted. In order to maintain a degree of conservatism, a value of 6 bpi was used as a maximum estimation of final driving resistance in Table 4.3. Note also that hammer energy in Table 4.3 is the hammer rated energy multiplied by hammer efficiency. Two sets of predicted pile capacity are provided in the table, one for piles that derive capacity from predominantly end-bearing action and one for piles that derive capacity from predominantly side friction action.

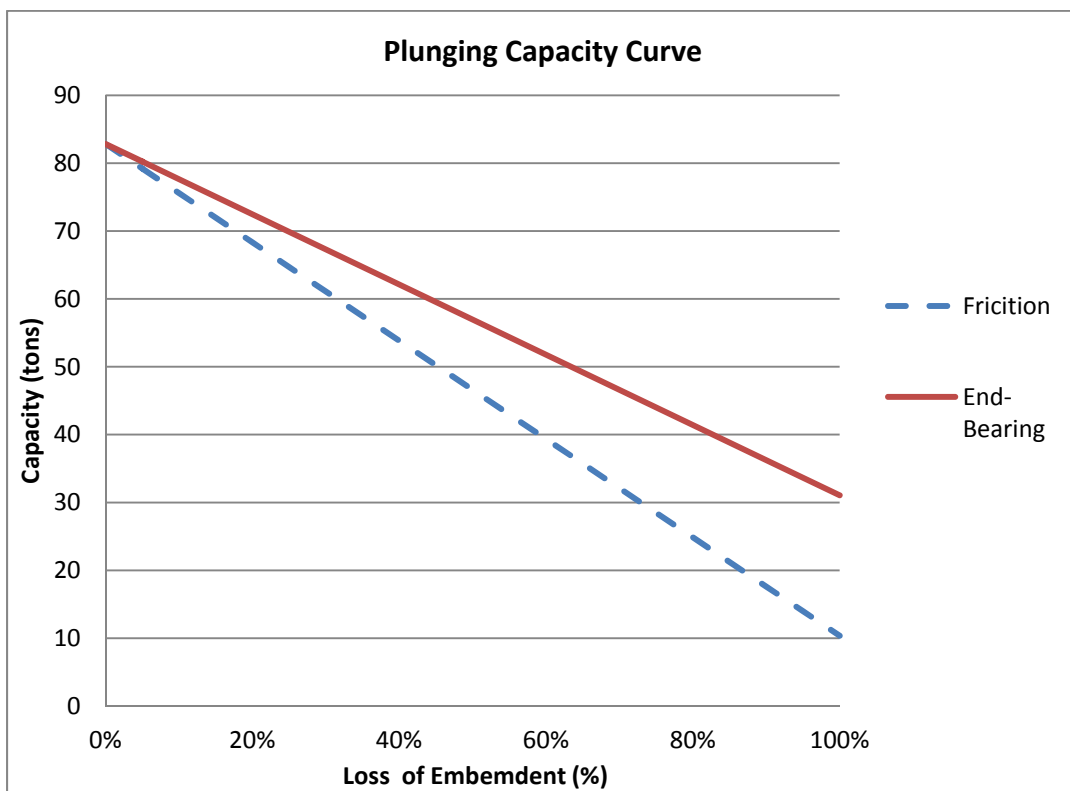


Values in Table 4.3 reflect a factor of safety of 1.25 used for pile plunging capacity. This factor of safety was used because the variable properties of timber do not affect pile plunging. Rather, the strength properties of the soil profile primarily govern pile plunging.

**Table 4.3 Predicted Pile Capacities Based on Modified Gates Formula for Timber Piles with F.S. = 1.25**

Hammer Energy (ft-lb)	Final Driving Resistance (blows/inch)	Allowable Resistance (tons)	End Bearing Pile Load Capacity (tons) (assume 75% tip resistance)					Friction Pile Load Capacity (tons) (assume 25% tip resistance)				
			% loss of embedment					% loss of embedment				
			0	20	40	60	80	0	20	40	60	80
2000	2	1	1	1	1	0	0	1	1	0	0	0
4000	2	18	18	15	13	11	9	18	15	12	9	5
6000	2	30	30	26	22	19	15	30	25	19	14	9
8000	2	41	41	36	31	26	20	41	34	27	19	12
10000	2	51	51	44	38	32	25	51	42	33	24	15
12000	2	60	60	52	45	37	30	60	49	39	28	18
15000	2	71	71	62	53	44	35	71	59	46	34	21
2000	4	10	10	9	7	6	5	10	8	6	5	3
4000	4	31	31	27	23	19	15	31	26	20	15	9
6000	4	47	47	41	35	29	23	47	39	31	22	14
8000	4	60	60	52	45	37	30	60	50	39	28	18
10000	4	72	72	63	54	45	36	72	59	47	34	22
12000	4	83	83	73	62	52	41	83	68	54	39	25
15000	4	97	97	85	73	61	48	97	80	63	46	29
2000	6	16	16	14	12	10	8	16	13	10	8	5
4000	6	39	39	34	29	24	19	39	32	25	19	12
6000	6	56	56	49	42	35	28	56	46	36	27	17
8000	6	71	71	62	53	44	35	71	59	46	34	21
10000	6	84	84	73	63	52	42	84	69	55	40	25
12000	6	96	96	84	72	60	48	96	79	62	46	29
15000	6	112	112	98	84	70	56	112	92	73	53	34

Assuming that the loss of plunging capacity is proportional to the loss of pile embedment as previously discussed, the critical scour value for which the pile will plunge can be determined for a given gravity load of  $P_{MaxApplied}$ . The critical percent loss of scour will be equal to the slope of the pile plunging capacity curve. An example plunging capacity curve is shown below for a 12,000 hammer energy (including hammer efficiency) and 4 bpi driving resistance. Note that the slopes of the curves are linear.



**Figure 4.4 Plunging Capacity Curves for 12,000 k-ft Driving Energy, 4 bpi Driving Resistance by Modified Gates Formula**

Therefore,

$$Slope = \frac{P_{After\ Scour} - P_{Allowable}}{\%Loss\ Embedment} \quad (4-7)$$

where the percent loss of embedment used corresponds to the value used to determine  $P_{After\ Scour}$  determined by Equation 4-5 or 4-6 for a friction or end-bearing pile, respectively.

Because the relationship is linear, any percent loss of embedment may be used to determine the slope of the curve. For the screening tool, the pile capacity for 80% loss of embedment is used. Therefore, Equation 4-7 becomes

$$\%Loss\ Embedment_{Critical} = \frac{P_{80\%Loss} - P_{Allowable}}{0.80} . \quad (4-8)$$

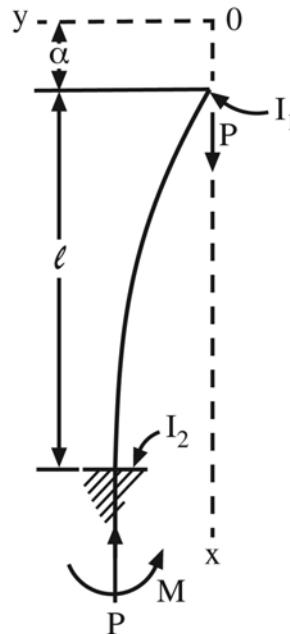
Critical scour, then, is

$$S_{cr} = \%Loss\ Embedment_{Critical} \cdot l_{bs} \quad (4-9)$$

where  $l_{bs}$  is the length of pile embedded in the soil before the scour event.

#### 4.4 Bent Pile Buckling Failure

The third failure mode in need of investigation is buckling. The generic buckled shape with coordinate axes is shown below in Figure 4.5. Recall that to account for the effects of varying moments of inertia, shown as  $I_1$  and  $I_2$  in the figure, an effective moment of inertia will be used.



**Figure 4.5 Buckled Shape and Coordinate Axes (Ramey et. al 2011)**

While bracing should be provided for timber pile bents due to the lack of moment resistant connections at the cap, both unbraced and braced bents are considered. Timber bent piles are not embedded in the bent cap, which is usually timber or concrete, but are approximately pinned to the cap. The screening tool conservatively assumes a pinned connection at the cap. For the pile-to-ground connection, fixity is based on the length of embedment. A total fixity (100%), partial fixity (50%), or pinned (0%) fixity condition is assigned based on the following ranges of embedment presented in Table 4.4:

**Table 4.4 Assumed Fixity Conditions Based on Embedment Length**

Embedment After Scour (ft)	Assumed Fixity	Buckling Coefficient, C
≥ 8 ft	100%	2.0
4 - 8 ft	50%	1.5
< 4 ft	0%	1.0

Recall that due to the presence of bridge abutments and the connectivity of the bridge superstructure to these abutments, bent piles cannot buckle in a sidesway mode in the longitudinal direction of the bridge. Owing to their circular cross-section, timber piles have the same moment of inertia,  $I$ , in both the longitudinal and transverse buckling directions. Therefore, non-sidesway buckling in the longitudinal direction typically controls buckling failure for smaller scour values.

Due to taper, flexural stiffness of a timber pile decreases exponentially along its length. Therefore, after excessive scour, sidesway buckling in the transverse direction below the cross-bracing can occur. In summary, the following buckling modes are considered in the screening tool:

- (1) Non-sidesway buckling in the longitudinal direction of braced and unbraced bents;
- (2) Sidesway buckling in the transverse direction of braced bents below cross-bracing;
- (3) Sidesway buckling in the transverse direction of unbraced bents.

For all buckling modes, the critical buckling mode equation will be a variation of the Euler buckling equation.

$$P_{cr} = \frac{C\pi^2 EI}{L^2} \quad (4-10)$$

The buckling coefficient, C, and buckling length, L, will vary for each mode based on the assumed buckling shape and embedment length. Recall that an effective moment of inertia must be used to account for the pile taper, as described in Chapter 3.

It should be noted that bridge spans are assumed to be simply supported, as is usual for timber bridges. Because of the possibility of transverse sidesway buckling in the lower unbraced regions of pile bents after scour, simply supported bridge spans will have smaller values of transverse buckling critical loads,  $P_{cr}$ , than continuous span bridges because the continuous span superstructure will prevent transverse sidesway buckling of the bents. Also, due to adjacent piles in a bent providing lean-on support to other piles in the bent, it is conservative to assume that the critical load for a bent is equal to the summation of the critical loads on all piles in that bent

$$P_{CR}^{Bent} = \sum_{n=1}^{No.Piles} P_{CR}^{Piles} \quad (4-11)$$

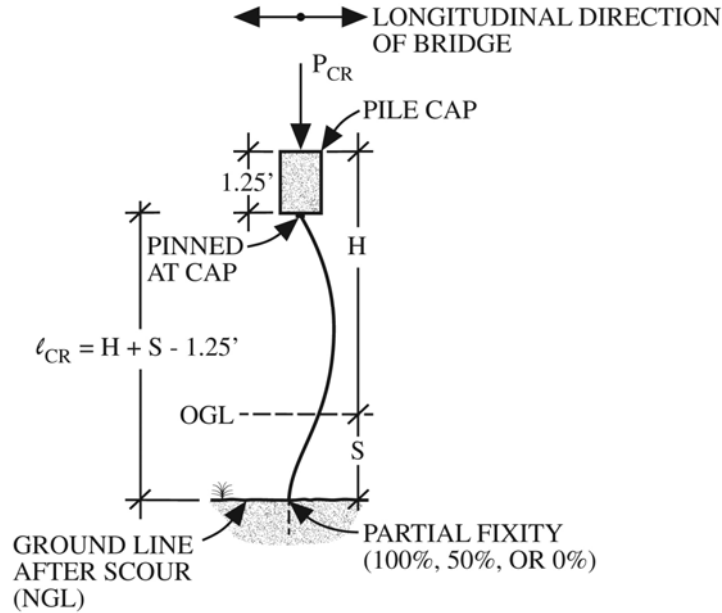
For purposes of the screening tool, it was assumed that bridge spans are simply supported and that if the most heavily loaded pile in a bent will not buckle, the entire bent will not buckle.

#### 4.4.1 Non-Sidesway Buckling in the Longitudinal Direction

For pile buckling in the longitudinal direction for both braced and unbraced bents, the following version of Equation 4-10 is used:

$$P_{cr} = \frac{C\pi^2EI_{eff}}{(H+S-1.25)^2} \quad (4-12)$$

The buckling length, L, is assumed to extend from the pile cap to the new ground line (NGL). This length is the addition of the bent height and the scour, minus the pile cap height, as shown in Figure 4.6. The depth of the pile cap is assumed to be 1.25 feet.



**Figure 4.6 Longitudinal Buckling Failure Mode for Braced and Unbraced Bents**

For ALDOT engineers, the critical buckling length and corresponding critical scour value is of more interest than the critical load. These values can be determined by rearranging Equation 4-12 as follows:

$$l_{cr} = \sqrt{\frac{C\pi^2 E I_{eff}}{1.33 P_{max}^{Pile}}} \quad (4-13)$$

$$s_{cr} = l_{cr} + 1.25 - H \quad (4-14)$$

The maximum unfactored load on a pile,  $P_{max}^{Pile}$ , is assumed to be known for a particular pile. Note that Equation 4-13 includes a factor of safety of 1.33.

The critical scour values and buckling lengths were determined for various pile sizes and applied loads, and the results can be seen in Table 4.5. These results were plotted to illustrate their relationship as shown in Figure 4.7. Note that with increasing bent height, the critical scour length decreases. Therefore, the taller bents will be the



most critical in buckling. In addition, the critical scour depth is less for a pile with a smaller effective diameter.

**Table 4.5 Critical Longitudinal Buckling Lengths and Critical Scour for Various Bent Parameters (E = 1,800 ksi, F.S. = 1.33)**

Pile Fixity, C	Geometric Parameters															
	$d_{eff}$ (in.)	6		7		8		9		10		11		12		
	$I_{eff}$ (in <sup>4</sup> )	64		118		201		322		491		719		1018		
	$EI_{eff}$ (k-in <sup>2</sup> )	144,500		212,400		361,800		579,600		883,800		1,294,200		1,832,400		
$P_{max}$ (kips)	Critical Values (ft)															
	$l_{cr}$	$s_{cr}$	$l_{cr}$	$s_{cr}$	$l_{cr}$	$s_{cr}$	$l_{cr}$	$s_{cr}$	$l_{cr}$	$s_{cr}$	$l_{cr}$	$s_{cr}$	$l_{cr}$	$s_{cr}$	$l_{cr}$	$s_{cr}$
1.0 (Pinned)	20	17.2	18.4-H	23.4	24.6-H	30.5	31.7-H	38.7	39.9-H	47.7	48.9-H	57.8	59.0-H	68.6	69.8-H	
	30	14.0	15.2-H	19.1	20.3-H	25.0	26.2-H	31.5	32.7-H	39.0	40.2-H	47.2	48.4-H	56.1	57.3-H	
	40	12.1	13.3-H	16.6	17.8-H	21.6	22.8-H	27.3	28.5-H	33.8	35.0-H	40.8	42.0-H	48.5	49.7-H	
	50	10.8	12.0-H	14.9	16.1-H	19.3	20.5-H	24.4	25.6-H	32.0	33.2-H	36.5	37.7-H	43.4	44.6-H	
	60	9.89	11.1-H	13.5	14.7-H	17.6	18.8-H	22.3	23.5-H	27.6	28.8-H	33.3	34.5-H	39.7	41.0-H	
1.5 (Partial)	20	21.1	22.3-H	28.7	29.9-H	37.4	38.6-H	47.4	48.6-H	58.4	59.6-H	70.7	71.9-H	84.1	85.3-H	
	30	17.2	18.4-H	23.4	24.6-H	30.6	31.8-H	38.7	39.9-H	47.7	48.9-H	57.8	59.0-H	68.7	69.9-H	
	40	14.9	16.1-H	20.3	21.5-H	26.4	27.6-H	33.5	34.7-H	41.3	42.5-H	50.0	51.2-H	59.5	60.7-H	
	50	13.3	14.5-H	18.2	19.4-H	23.7	24.9-H	29.9	31.1-H	37.0	38.2-H	44.7	45.9-H	53.2	54.4-H	
	60	12.1	13.3-H	16.6	17.8-H	21.6	22.8-H	27.3	28.5-H	33.8	35.0-H	40.9	42.1-H	48.6	49.8-H	
2.0 (Fixed)	20	24.4	25.6-H	33.1	34.3-H	43.1	44.3-H	54.7	55.9-H	81.7	68.6-H	97.1	82.9-H	68.6	98.3-H	
	30	19.9	21.1-H	27.0	28.2-H	35.3	36.5-H	44.6	45.8-H	66.7	56.2-H	79.3	67.9-H	56.1	80.5-H	
	40	17.2	18.4-H	23.4	24.6-H	30.5	31.7-H	38.6	39.8-H	57.8	48.9-H	68.6	59.0-H	48.5	69.8-H	
	50	15.3	16.5-H	20.9	22.1-H	27.3	28.5-H	34.6	35.8-H	51.6	43.9-H	61.4	52.8-H	43.4	62.6-H	
	60	14.0	15.2-H	19.1	20.3-H	24.8	26.0-H	31.5	32.7-H	47.1	40.2-H	56.2	48.3-H	39.7	57.4-H	

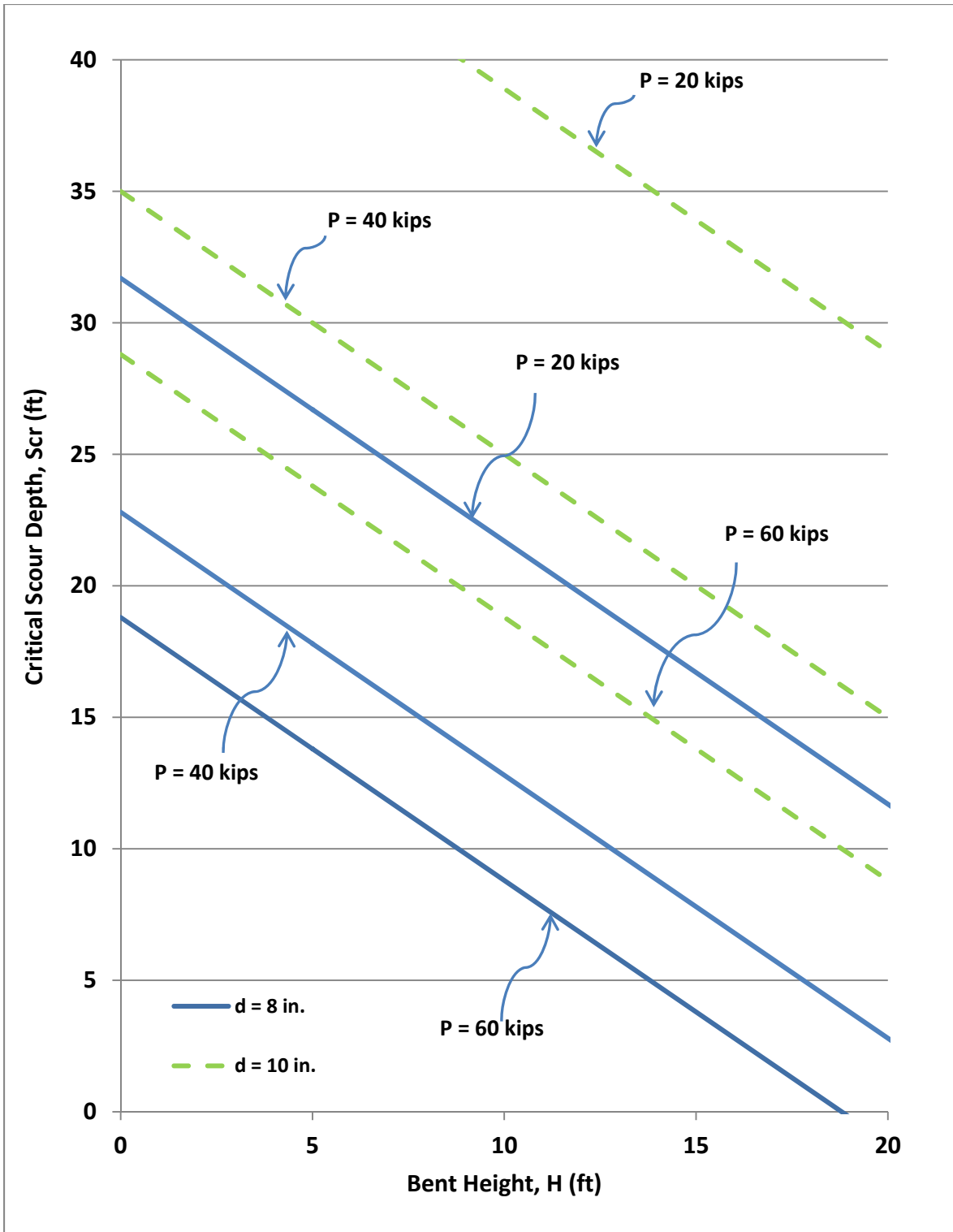


Figure 4.7 Critical Scour ( $S_{cr}$ ) versus Bent Height ( $H$ ) for Longitudinal Buckling of Timber Pile Bents (F.S. = 1.33)

#### 4.4.2 Buckling in the Transverse Direction for Braced Bents

For bents with low levels of scour, the bracing will prevent sidesway buckling in the transverse direction of the bridge. Therefore, if the piles buckle, it will be non-sidesway buckling shown as Mode 1 as shown in Figure 4.7. However, with excessive scour, a large length of pile can become exposed below the cross-bracing, allowing for sidesway buckling as shown as Mode 2 in Figure 4.8. By comparing Figure 4.6, non-sidesway buckling in the longitudinal direction, and Figure 4.8 Mode 1, non-sidesway buckling in the transverse direction, it can be determined that for non-sidesway buckling, the longitudinal direction will control because its critical buckling length will always be longer.

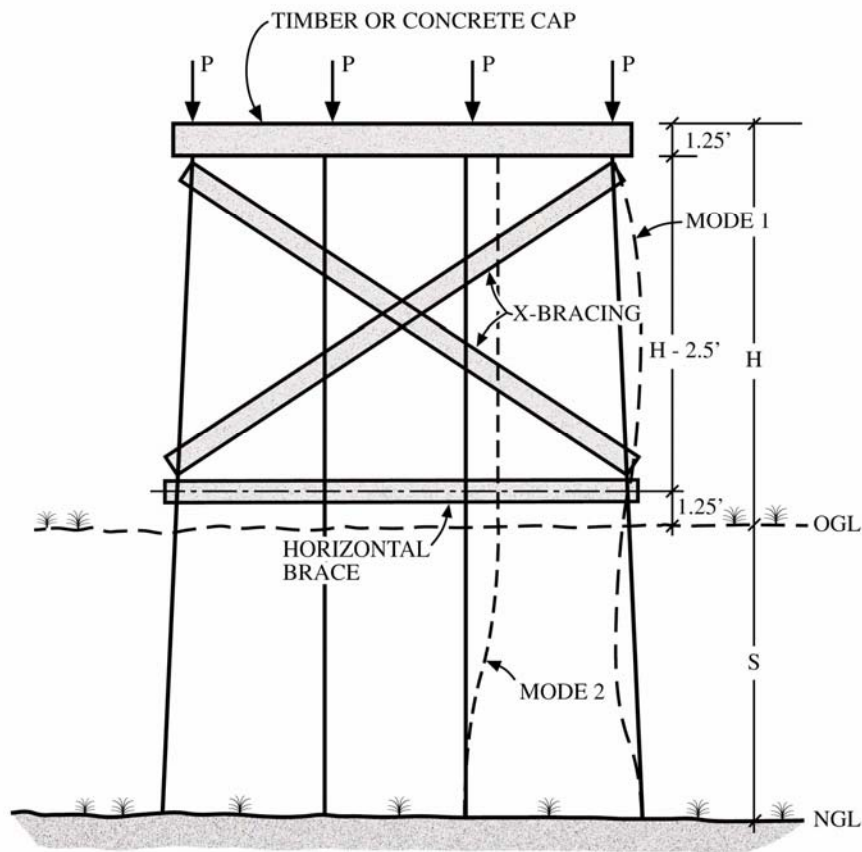
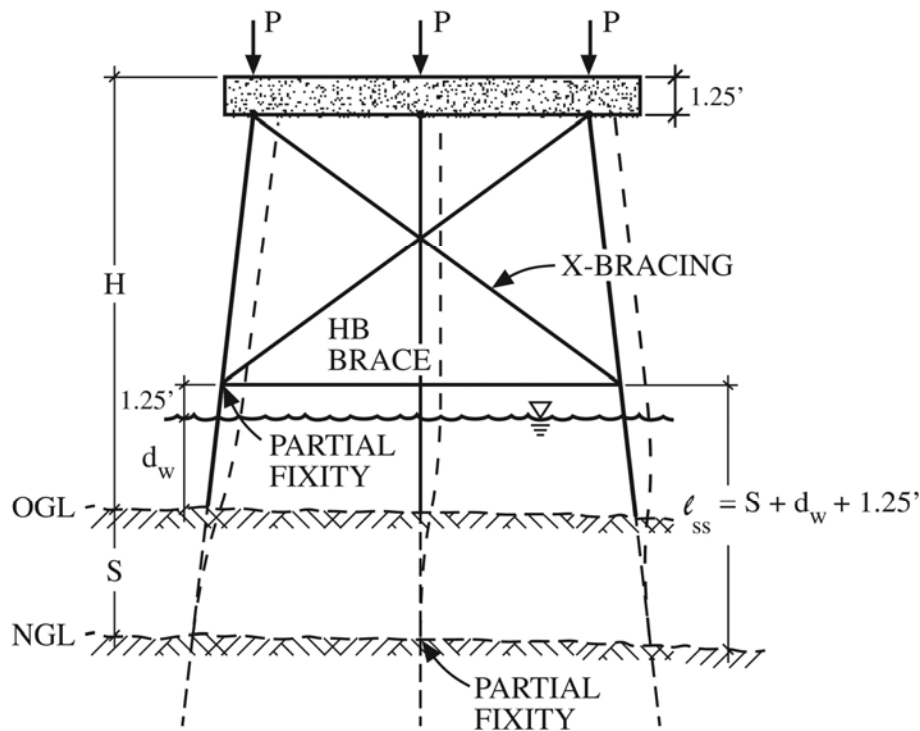


Figure 4.8 Buckling in the Transverse Direction for Braced Bents

In bents constructed over water, the bottom horizontal brace is located approximately 1.25 feet above the water line, rather than 1.25 feet directly above the ground line, as shown in Figure 4.9. In these cases, the buckling length below the bracing will include the scour depths, original water depth,  $d_w$ , and the 1.25 feet between the water line and the horizontal brace.



**Figure 4.9 Critical Buckling Lengths for Braced Bents over Water**

Equations for determining critical loads for sidesway buckling below the cross-bracing use another variation of the Euler buckling equation. The buckling coefficient is assumed as 0.5. The buckling length,  $L$ , also only includes the region below the horizontal cross-brace. In addition, the effective section height must be chosen to represent the different critical buckling length. Instead of taking the two-thirds height of

the entire pile length, as with longitudinal buckling, only the transverse critical buckling length below the bracing should be used when determining the effective section height. This will result in a smaller effective moment of inertia when compared to the longitudinal buckling mode. Therefore, for a bent out of water, the critical load for sidesway buckling below the horizontal brace is as follows:

$$P_{cr} = \frac{0.50\pi^2 EI_{eff}}{(S+1.25)^2} \quad (4-15)$$

Likewise, the critical load for sidesway buckling below the horizontal brace for a bent over water is as follows:

$$P_{cr} = \frac{0.5\pi^2 EI_{eff}}{(S+d_w+1.25)^2} \quad (4-16)$$

The previous two critical load equations were rearranged to determine the critical buckling lengths and corresponding critical scour depths for ALDOT screening purposes, as was done with buckling in the longitudinal direction. The resulting equation for the critical buckling length is as follows:

$$\ell_{cr} = \sqrt{\frac{0.5\pi^2 EI}{1.33 P_{max}^{Pile}}} \quad (4-17)$$

A factor of safety of 1.33 is placed on the maximum unfactored pile applied load. The critical scour length is then determined from the following equations. For a bent out of water the critical scour depth is

$$s_{cr} = \ell_{cr} - 1.25. \quad (4-18)$$

For a bent over water, the critical scour depth is

$$s_{cr} = \ell_{cr} - (1.25 + d_w). \quad (4-19)$$

If the maximum estimated scour at the bent is less than the critical scour, the bent is assumed safe.

The critical buckling lengths and scour depths for various pile geometries and applied loads were determined, and are tabulated in Table 4.6.

**Table 4.6 Critical Transverse Sidesway Buckling Lengths and Critical Scour Values for Various Braced Bent Parameters (E = 1800 ksi and F.S. = 1.33)**

Pile Parameters	Pile $d_{eff}$ , $I_{eff}$ , $EI_{eff}$ Values						
	6	7	8	9	10	11	12
$d_{eff}$ (in)	6	7	8	9	10	11	12
$I_{eff}$ (in <sup>4</sup> )	64	118	201	322	491	719	1018
$EI_{eff}$ (kin <sup>2</sup> )	114,500	212,400	361,800	579,600	883,800	1,294,200	1,832,400
$P_{max\ applied}$ (kips)	$\ell_{CR2}$ (ft) Values						
	20	12.1	16.6	21.6	27.3	33.8	40.9
30	9.92	13.5	17.6	22.3	27.5	33.3	39.7
40	8.59	11.7	15.3	19.3	23.9	28.9	34.4
50	7.68	10.5	13.7	17.3	21.3	25.8	30.7
60	7.01	9.55	12.4	15.8	19.4	23.6	28.0
$P_{max\ applied}$ (kips)	$S_{CR2}$ (ft) Values						
	20	10.8	15.3	20.3	26.1	32.6	39.7
30	8.67	12.2	16.3	21.1	26.3	32.1	38.5
40	7.34	10.4	14.1	18.1	22.7	27.7	33.2
50	6.43	9.25	12.5	16.1	20.1	24.6	29.5
60	5.76	8.30	11.3	14.7	18.2	22.4	26.8

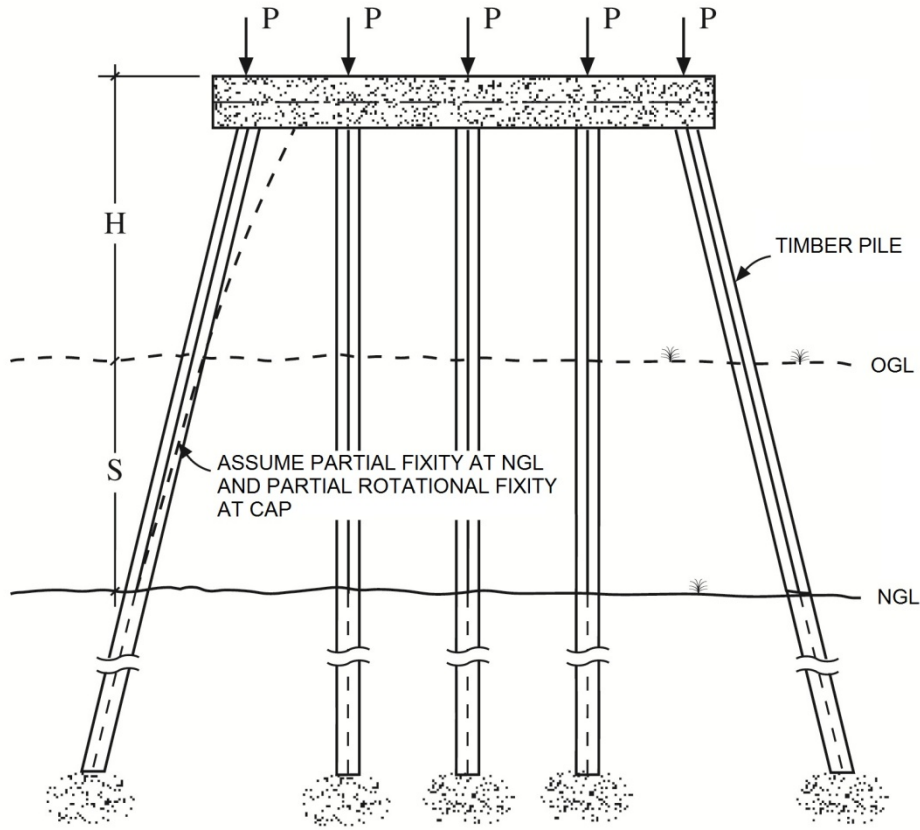
#### 4.4.3 Buckling in the Transverse Direction for Unbraced Bents

While timber bents should be cross-braced, some bents are reported as unbraced, as shown in Figure 4.10. In these cases, the critical buckling load is determined from the following equation:

$$P_{cr} = \frac{0.167\pi^2 EI_{eff}}{(S+H-1.25)^2} \quad (4-20)$$

The buckling coefficient, C, is assumed to be 0.167 to account for the weak partial fixity at the new ground line and the partial rotational resistance at the cap. The buckling

length is the same as for non-sideways buckling in the longitudinal direction. The effective section height, then is also determined in the same manner as longitudinal buckling, i.e. using the full length of exposed pile after scour.



**Figure 4.10 Sidesway Buckling of Unbraced Timber Bents**

Again, the critical load equation was rearranged to determine critical buckling length and scour depth. The resulting equation, including a factor of safety of 1.33 is as follows:

$$\ell_{cr} = \sqrt{\frac{0.167 \pi^2 E I_{eff}}{1.33 P_{max}^{pile}}} \quad (4-21)$$

The corresponding critical depth of scour is

$$s_{cr} = \ell_{cr} + 1.25 - H \quad (4-22)$$



The critical scour and buckling lengths for transverse sidesway buckling of unbraced bents were determined for various pile sizes and applied loads. The results can be seen in Table 4.7.

**Table 4.7 Critical Transverse Sidesway Buckling Lengths and Critical Scour for Various Unbraced Bent Parameters (E = 1,800 ksi and F.S. = 1.33)**

Pile Parameters	Pile $d_{eff}$ , $I_{eff}$ , $EI_{eff}$ Values						
	6	7	8	9	10	11	12
$d_{eff}$ (in)	6	7	8	9	10	11	12
$I_{eff}$ (in <sup>4</sup> )	64	118	201	322	491	719	1018
$EI_{eff}$ (k-in <sup>2</sup> )	114,500	212,400	361,800	579,600	883,800	1,294,200	1,832,400
$P_{max\ applied}$ (kips)	$\ell_{CR}$ (ft) Values						
	20	7.01	9.55	12.5	15.8	19.4	23.6
30	5.72	7.80	10.2	12.8	15.9	19.2	22.9
40	4.96	6.75	8.81	11.1	13.8	16.7	19.8
50	4.44	6.04	7.88	9.98	12.3	14.9	17.7
60	4.05	5.51	7.20	9.11	11.2	13.6	16.1
$P_{max\ applied}$ (kips)	$S_{CR}$ (ft) Values						
	20	8.26 - H	10.8 - H	13.8 - H	17.0 - H	20.6 - H	24.8 - H
30	6.97 - H	9.05 - H	11.4 - H	14.0 - H	17.1 - H	20.4 - H	24.1 - H
40	6.21 - H	8.00 - H	10.1 - H	12.3 - H	15.0 - H	17.9 - H	21.0 - H
50	5.69 - H	7.29 - H	9.13 - H	11.2 - H	13.5 - H	16.1 - H	19.0 - H
60	5.30 - H	6.76 - H	8.45 - H	10.4 - H	12.4 - H	14.8 - H	17.3 - H

#### 4.4.4 Summary of Buckling Modes

All the equations of buckling for braced and unbraced bents are summarized below in Table 4.8. By comparison of Equation 4-12 (for non-sidesway buckling in the longitudinal direction) with Equation 4-20 (for sidesway buckling in the transverse direction), it can be determined that transverse sidesway buckling will control for unbraced bents due to its identical buckling lengths, but lower C value. Therefore, the screening tool does not consider longitudinal buckling for unbraced bents.

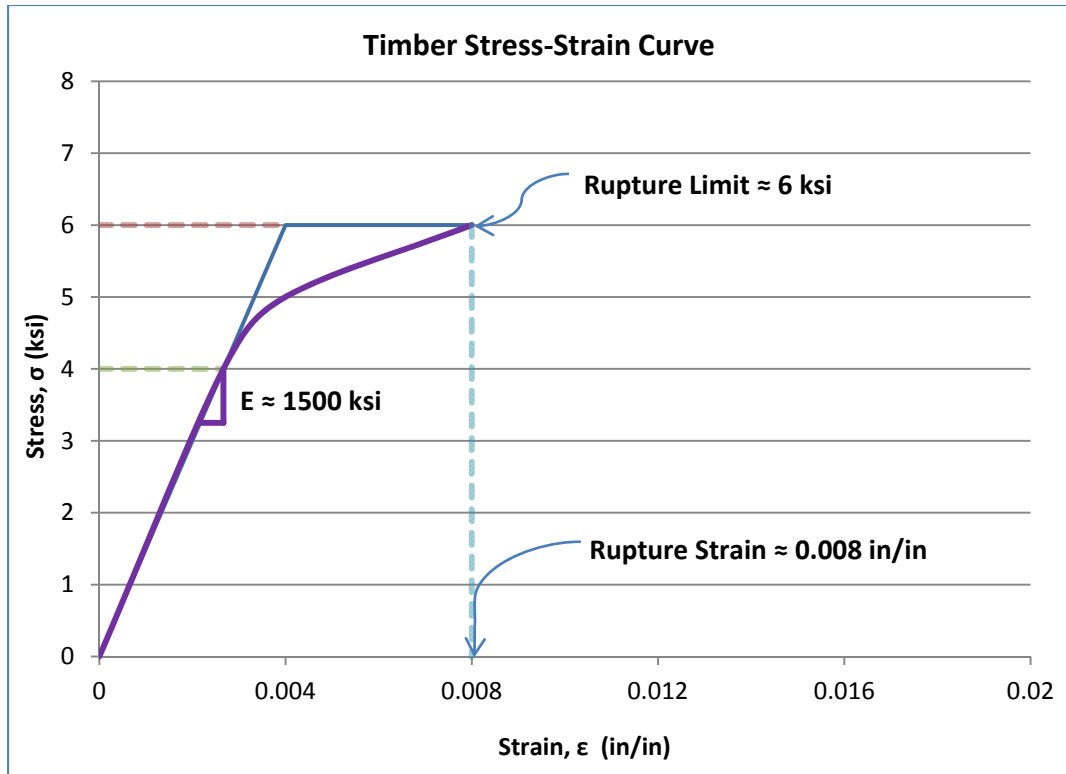
**Table 4.8 Equations of Buckling for Braced and Unbraced Bents**

Bracing Scheme	Buckling Mode	Buckling Coefficient, C	Critical Buckling Length	
			Bent Not Over Water	Bents Over Water
Braced	Longitudinal Non-sidesway	1.0 - 2.0	H + S - 1.25 ft	Same
	Transverse Sidesway	0.5	S + 1.25 ft	S + d <sub>w</sub> + 1.25 ft
Unbraced	Longitudinal Non-sidesway	1.0 - 2.0	H + S - 1.25 ft	Same
	Transverse Sidesway	0.167	H + S - 1.25 ft	Same

Note that the effective section height is dependent on the critical buckling length. For both non-sidesway buckling in the longitudinal direction and sidesway buckling in the transverse direction for unbraced bents, the entire pile length exposed after scour is used to determine the effective moment of inertia. Therefore, the same effective moment of inertia would be used. For sidesway buckling in the transverse direction below the horizontal brace (for braced bents) only the pile length below the horizontal brace is used to determine the effective moment of inertia. Therefore, calculations for sidesway buckling below the bracing will use a smaller effective moment of inertia.

#### 4.5 Bent Pushover Failure

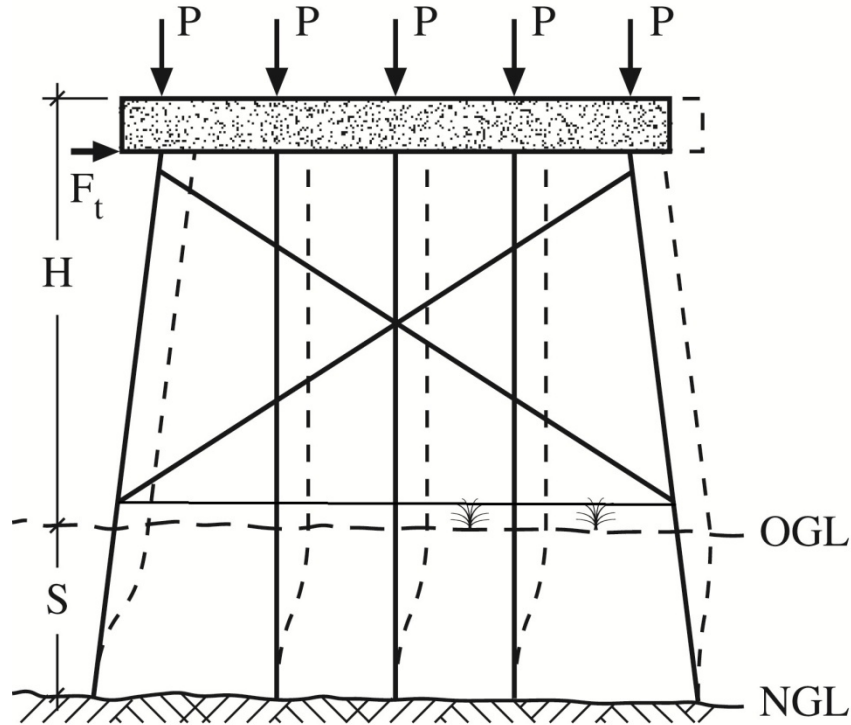
Pushover analysis is a nonlinear analysis procedure first used in seismic analyses based on a conventional displacement method of analysis (Daniels et al. 2007). Standard elastic and geometric stiffness matrices for the structural elements are progressively modified to account for geometric and material non-linearity under constant gravity loads and incrementally increasing lateral loads. For this screening tool, the stress-strain curve shown in Figure 4.11 was used to describe the nonlinear material behavior of timber.



**Figure 4.11 Stress-Strain Curve for Nonlinear Pushover of Timber Bents**

Note that with increases in stress above the approximately 4 ksi, the material begins to soften before rupture. An accurate nonlinear analysis must include this material nonlinearity.

Extreme flood water loadings, in conjunction with ever-present gravity loads on a bridge pile bent, can be a controlling loading condition if the bent transverse load,  $F_t$ , and scour,  $S$ , are large as shown in Figure 4.12. Even for bents that are braced in the transverse direction, a significant  $P-\Delta$  effect can occur which can induce a bent pushover failure in the region from the new ground line (NGL) to the lower horizontal brace as indicated in Figure 4.12.

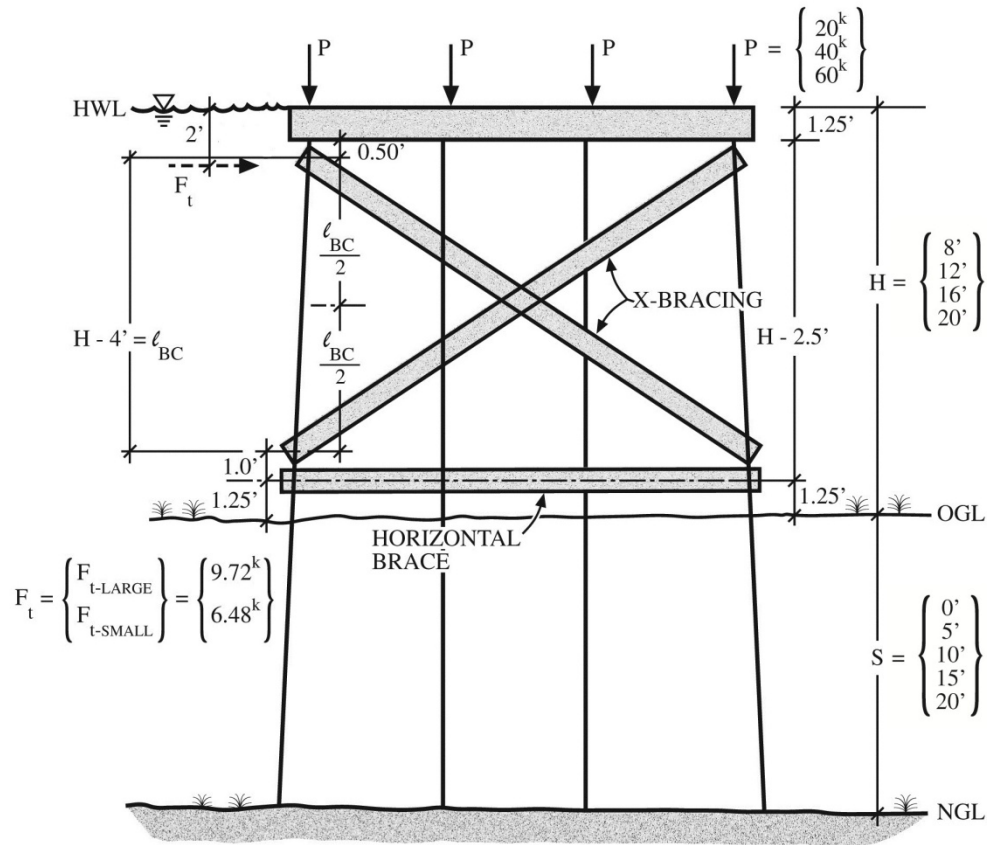


**Figure 4.12 Typical Braced Bent Pushover Failure**

In simple cases, linear eigenvalue analyses may be sufficient for design evaluation. However, the failure of timber bridges subjected to scour may be defined by a combination of large deflection instability and material softening or rupture. Therefore, nonlinear incremental analyses were performed using the Riks method to solve for the nonlinear equilibrium path (Simulia 2007). This approach provides solutions regardless of whether the response is stable or unstable.

For this screening tool, the critical pushover load location was assumed to correspond to the high water line (HWL) located at the top of the bent, as shown in Figure 4.13. Recall that while the raft is assumed at the top of the bent, the force is assumed to act through the centroid of the raft, or 2 feet below the top of the bent. Recall that the small and large debris raft forces,  $F_t$ , are 9.72 and 6.48 kips, as

previously determined in Chapter 3. The assumed typical bent geometry is shown in Figure 4.13.

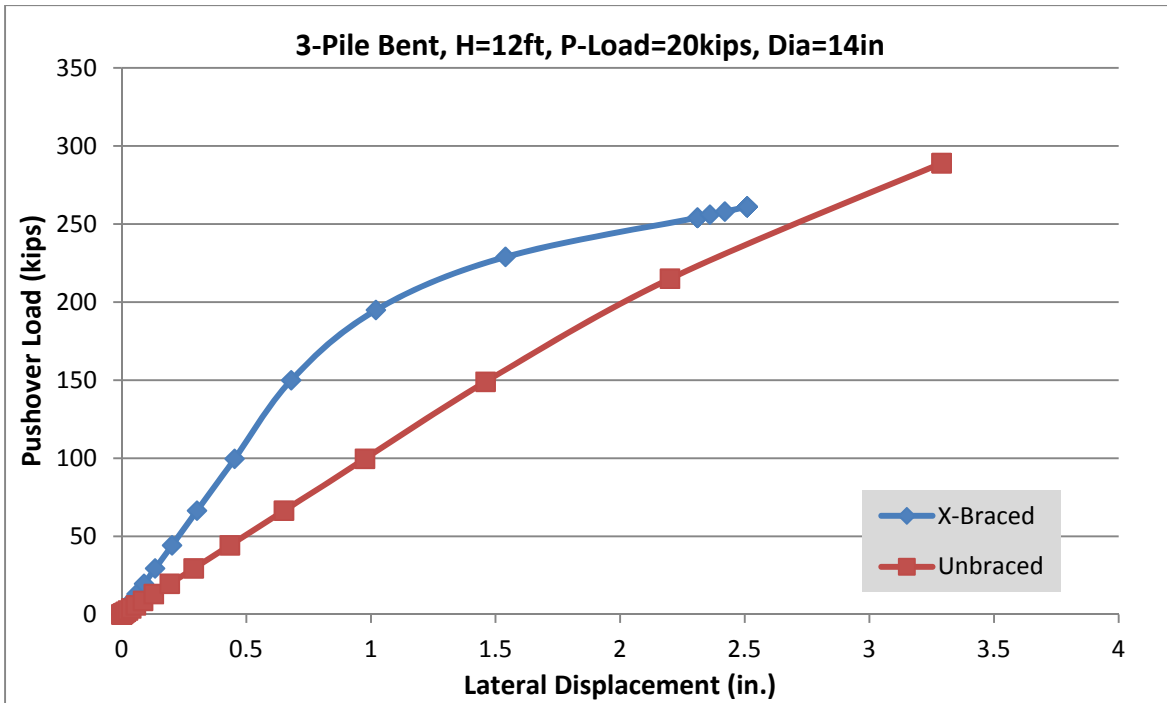


**Figure 4.13 Critical Debris Raft Location for Pushover Failure**

A typical pushover load-displacement curve for a braced and unbraced timber pile bent is shown in Figure 4.14. The gravity (P-loads) on the bents are applied before the Riks procedure begins, and are held constant through each analysis. After application of the P-loads, the lateral flood water load,  $F_t$ , is incrementally increased until the system becomes unstable. After the initial lateral load increment is provided, subsequent iterations and load increments are computed automatically. After each load increment, the bent stiffness matrix is modified to account for changes in geometry due

to deformations of the members of the bent, and to account for the varying stress-strain levels occurring in the members. Thus, both geometric and material nonlinearity of the members are included in the analysis; this method provides an accurate evaluation of the capacity of the bents. All the pushover curves produced by the finite element software can be seen in Appendix A and B for braced and unbraced bents, respectively.

Figure 4.14 shows example pushover curves for a 3-pile, 14 in. diameter timber pile bent in both the braced and unbraced condition. The gravity concentrated pile load is 20 kips and scour is not present ( $S = 0$  ft). For the braced pile bent, the pushover force (the asymptotic value) is 260 kips. In the screening tool, then, if the expected lateral force from the debris raft is less than 260 kips, the bent is safe from pushover failure. For the unbraced bent, the pushover force is 289 kips. Note that while the unbraced bent reaches a higher pushover load, it withstands 1 inch more deflection than the braced bent. This is indicative of the stiffness provided by braced bents.



**Figure 4.14 Bent Pushover Curve for 3-Pile, 12 ft Bent Height, 14 in. Pile Butt Diameter, 20 kip P-load, and No Scour**

The lateral force, produced by a debris raft, is a function of the span length which accumulates debris. The larger the span length, the larger the debris raft that may accumulate on a bent. Depending on the bridge span lengths, the factored maximum applied lateral load will be taken as either 8.62 or 12.93 kips for short and long spans, respectively.

Bent pushover loads obtained from the finite element method analyses are presented in Tables 4.10 through Table 4.13 as a set of  $F_t^{Pushover}$  tables. The bent scenarios that were analyzed are presented in Table 4.9.

**Table 4.9 Timber Pile Bent Cases Analyzed for Pushover**

<b>Parameter</b>	<b>Scenarios Considered</b>
Bracing Condition	Braced and Unbraced
Number of Piles in Bent	3, 4, 5
Height (ft)	8, 12, 16, 20
Pile Butt Diameter (in)	12, 14
P-Load Applied (kips)	20, 40, 60
Scour (ft)	0, 5, 10, 15, 20



**Table 4.10 Pushover Loads  $F_t$  for Braced, 12 in. Pile Butt Diameter Bents**

Number of Piles in Bent	Bent Height (ft)	Scour (ft)	Pushover Loads (kips)		
			Pile Load (kips)		
			20	40	60
3	8	0	250	249	247
		5	150	149	148
		10	113	112	110
		15	99.9	97.7	93.2
		20	85.5	82.9	80.3
	12	0	256	255	254
		5	167	167	166
		10	108	107	112
		15	122	118	108
		20	98.0	81.4	101
	16	0	228	227	226
		5	180	191	178
		10	145	137	143
		15	135	132	130
		20	113	109	102
	20	0	228	227	153
		5	143	174	146
		10	138	127	145
		15	113	110	109
		20	101	97.2	90.1
4	8	0	258	255	253
		5	166	163	160
		10	127	123	121
		15	88.3	86	83.9
		20	72.8	74.1	71.6
	12	0	278	271	275
		5	166	164	179
		10	146	144	142
		15	109	107	105
		20	91.8	91.4	88.7
	16	0	284	283	280
		5	166	162	191
		10	155	162	159
		15	105	111	102
		20	118	114	110
	20	0	198	196	195
		5	189	188	186
		10	156	153	147
		15	147	143	137
		20	128	118	109

**Table 4.10 (Continued) Pushover Loads  $F_t$  for Braced,  
12 in. Pile Butt Diameter Bents**

Number of Piles in Bent	Bent Height (ft)	Scour (ft)	Pushover Loads (kips)		
			Pile Load (kips)		
			20	40	60
5	8	0	256	248	243
		5	162	157	152
		10	97.2	108	99.3
		15	80.2	77.5	74.8
		20	70.2	67.1	64.0
	12	0	257	253	274
		5	160	158	178
		10	131	131	132
		15	112	105	103
		20	94.1	90.9	87.5
	16	0	236	230	234
		5	206	191	190
		10	147	159	158
		15	108	106	103
		20	90.7	87.5	84.2
	20	0	263	247	248
		5	207	206	207
		10	165	158	114
		15	101	146	143
		20	117	109	77.3

**Table 4.11 Pushover Loads  $F_t$  for X-Braced, 14 in. Pile Diameter Bents**

Number of Piles in Bent	Bent Height (ft)	Scour (ft)	Pushover Loads (kips)		
			Pile Load (kips)		
			20	40	60
3	8	0	250	249	247
		5	162	161	159
		10	123	122	120
		15	89.3	99.4	86.7
		20	78.7	77.6	76.6
	12	0	261	260	253
		5	192	191	190
		10	135	130	136
		15	115	113	114
		20	104	99.3	97.9
	16	0	228	227	226
		5	159	158	157
		10	155	154	155
		15	134	142	140
		20	107	106	104
	20	0	229	228	227
		5	171	173	178
		10	140	100	138
		15	136	135	133
		20	115	113	119
4	8	0	258	255	252
		5	165	163	160
		10	126	123	121
		15	86.7	85.6	84.1
		20	75.3	73.9	72.0
	12	0	280	278	277
		5	205	202	202
		10	135	134	133
		15	114	113	111
		20	101	99.1	97.2
	16	0	283	281	280
		5	190	186	186
		10	162	160	159
		15	119	115	106
		20	103	103	101
	20	0	215	251	250
		5	149	183	182
		10	161	162	160
		15	147	145	144
		20	134	133	131

**Table 4.11 (Continued) Pushover Loads  $F_t$  for-Braced,  
14 in. Pile Butt Diameter Bents**

Number of Piles in Bent	Bent Height (ft)	Scour (ft)	Pushover Loads (kips)		
			Pile Load (kips)		
			20	40	60
5	8	0	253	248	243
		5	162	131	131
		10	97.3	99.3	97.7
		15	85.8	84.4	75.5
		20	69.6	66.9	64.6
	12	0	254	234	244
		5	172	203	166
		10	130	127	127
		15	123	108	106
		20	96.8	94.7	92.5
	16	0	236	232	221
		5	238	236	233
		10	147	146	157
		15	123	121	119
		20	105	103	101
	20	0	275	273	248
		5	228	194	166
		10	163	161	160
		15	114	112	111
		20	131	128	125

**Table 4.12 Pushover Loads  $F_t$  for Unbraced, 12 in. Pile Butt Diameter Bents**

Number of Piles in Bent	Bent Height (ft)	Scour (ft)	Pushover Loads (kips)		
			Pile Load (kips)		
			20	40	60
3	8	0	289	289	288
		5	163	162	164
		10	104	102	98.3
		15	69.4	64.9	61.0
		20	46.8	41.3	37.0
	12	0	183	181	164
		5	115	108	99.9
		10	75.6	71.0	61.5
		15	50.5	46.0	40.7
		20	29.5	28.8	23.1
	16	0	122	120	107
		5	80.3	78.1	67.5
		10	53.3	50	44.9
		15	37.1	31.8	26.3
		20	19.9	18.4	12.3
4	8	0	411	231	408
		5	224	222	221
		10	133	131	135
		15	95.2	92.7	88.1
		20	68.5	47.0	59.4
	12	0	289	231	230
		5	152	153	148
		10	104	100	95.9
		15	73.6	68.8	60.0
		20	55.2	47.0	43.8
	16	0	164	155	154
		5	113	109	103
		10	63.4	62.7	68.4
		15	65.3	59.7	53.5
		20	43.8	38.5	31.9
5	8	0	501	231	230
		5	287	153	149
		10	180	100	95.9
		15	73.6	68.8	60.0
		20	55.2	47.0	43.8
	12	0	291	290	288
		5	191	188	186
		10	132	128	123
		15	94.5	89.2	83.8
		20	70.1	63.4	56.7
	16	0	210	202	193
		5	142	139	148
		10	101	97.4	61.3
		15	75.5	67.4	61.3
		20	58.3	47.3	42.4

**Table 4.13 Pushover Loads  $F_t$  for Unbraced, 14 in. Pile Butt Diameter Bents**

Number of Piles in Bent	Bent Height (ft)	Scour (ft)	Pushover Loads (kips)		
			Pile Load (kips)		
			20	40	60
3	8	0	495	451	450
		5	277	276	275
		10	180	178	174
		15	121	119	116
		20	86.7	83.3	78.6
	12	0	289	288	283
		5	198	187	186
		10	131	129	125
		15	92.1	89.8	86.0
		20	67.5	55.2	58.3
	16	0	203	208	206
		5	142	138	136
		10	97.3	95	92.4
		15	72.2	64.9	54.7
		20	46.2	47.2	41.0
4	8	0	644	643	642
		5	376	374	364
		10	242	240	238
		15	166	164	161
		20	88.9	85.5	115.0
	12	0	410	409	408
		5	258	258	257
		10	142	160	159
		15	129	126	122
		20	69.0	91.9	87.0
	16	0	281	279	277
		5	191	189	187
		10	139	136	131
		15	118	110	106
		20	54.2	48.7	68.9
5	8	0	744	743	741
		5	440	470	468
		10	289	302	297
		15	212	206	203
		20	155	136	145
	12	0	501	499	504
		5	329	327	324
		10	228	221	218
		15	166	161	153
		20	125	119	111
	16	0	340	354	351
		5	231	229	227
		10	178	172	163
		15	134	126	118
		20	104	95.4	88.7

#### 4.6 Beam-Column Failure

The final failure mode that is evaluated is failure of the upstream pile as a beam-column. As previously discussed in Section 4.5 for bent pushover, in extreme scour events a debris raft may form at a bent, inducing a lateral load. This lateral load causes bending in the upstream pile, while the gravity loads on the bridge cause an axial column load. Thus, the upstream pile functions as a beam-column. As shown in Figure 4.15, the critical location for the lateral raft load was determined to be located at the center of the cross-bracing (Ramey et al. 2006). At this section, the stiffness provided by the bracing has its least influence and the most bending would be produced by the lateral raft force.

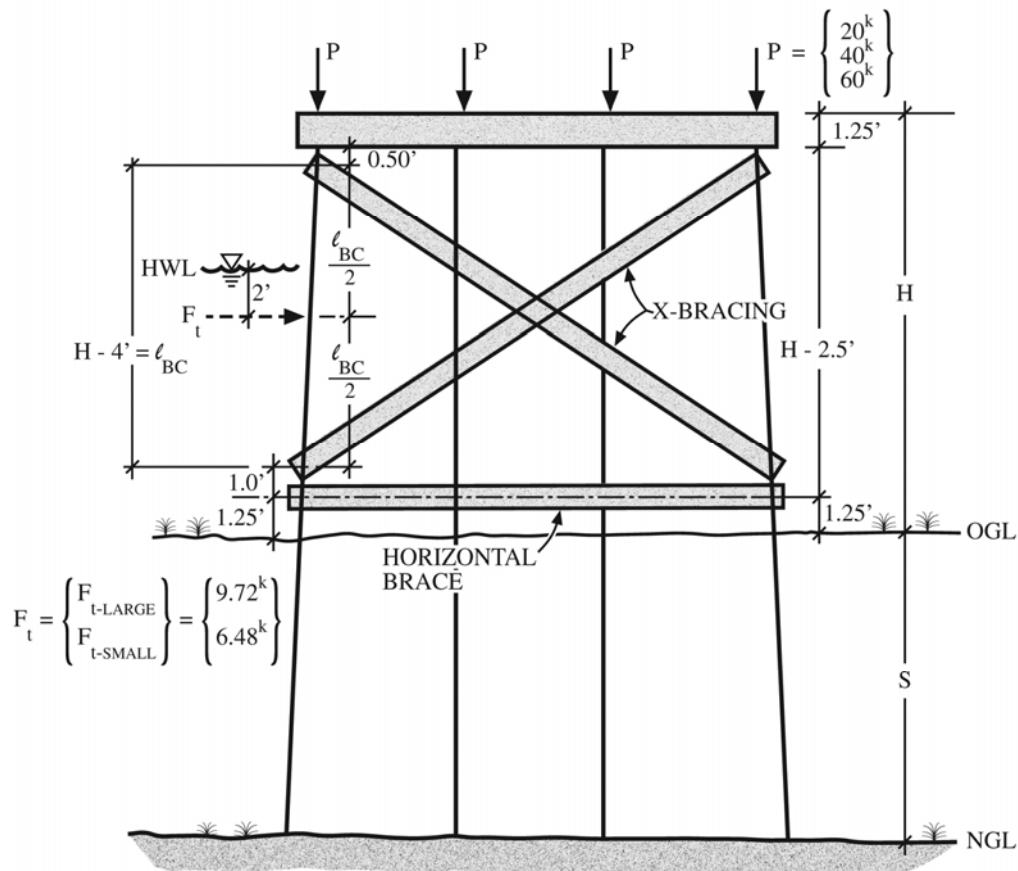
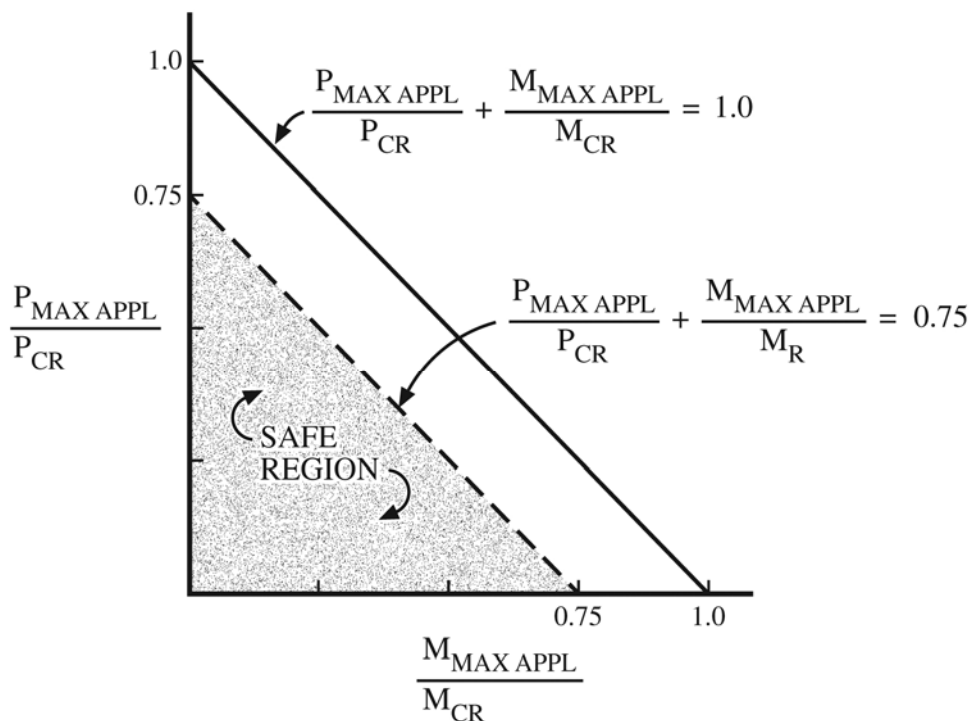


Figure 4.15 Beam-Column Failure for Typical Braced Bent

In checking the adequacy of the upstream pile as a beam-column, a straight-line interaction equation was used:

$$\frac{P_{applied}}{P_{capacity}} + \frac{M_{applied}}{M_{capacity}} \leq \frac{1.0}{F.S.} \quad (4-23)$$

Figure 4.16 shows a plot of straight-line ultimate interaction Equation 4-23 without applying a factor of safety, in addition to an allowable loading straight-line interaction equation with a factor of safety of 1.33. The latter equation is used in the screening tool. Note the factor of safety is not then applied directly to the debris raft as previously discussed with the bent pushover analyses.



**Figure 4.16 Assumed Ultimate and Allowable Load Interaction Equations**

The axial capacity,  $P_{CR}$ , is governed by either the crushing or buckling load of the pile. The bending capacity,  $M_R$ , is governed by the stress at rupture. Due to multiple



possible bent geometries and loading conditions, extreme cases for braced and unbraced bents were investigated and then the safety of all other cases were extrapolated from the results. These derivations are discussed in this section and may also be seen in Appendix C.

#### 4.6.1 Beam-Column Failure Analysis

As previously described, the capacities for bending and axial loads are first determined, then compared to the applied loads. For axial capacity it must be determined whether crushing or buckling will control. The crushing stress was assumed as 7.0 ksi. The critical buckling load is determined by the following equation for braced bents:

$$P_{cr} = \frac{2\pi^2 E I_{eff}}{L^2} \quad (4-24)$$

For unbraced bents, the critical buckling load is determined by the following:

$$P_{cr} = \frac{0.25\pi^2 E I_{eff}}{L^2} \quad (4-25)$$

Because buckling is a global phenomenon, the effective moment of inertia is used to take the taper into account.

If the critical buckling stress is less than 7.0 ksi, buckling is assumed to control axial capacity. To convert the crushing stress to a crushing load, the following relationship is used:

$$P_{crushing} = \sigma_{crushing} \cdot A_{base} \quad (4-26)$$

Note that crushing load is determined using the cross-sectional area of the pile at the base. Using the base diameter is conservative, due to the decreasing taper. The minimum value of the crushing versus buckling critical load is assumed to control. For

all timber pile bent cases, buckling controls. As discussed in Chapter 3, the crushing load is 198 kips for even the smallest diameter possible, 6 inches. The maximum considered pile applied load is 60 kips, much lower than the minimum crushing load.

For the bending capacity term of the interaction equation, a maximum bending moment is produced by the application of the lateral debris raft loading. For the most conservative approach, the smallest cross-section (i.e. at the new ground line) is used to determine the rupture moment as follows:

$$M_{rupture} = \sigma_{rupture} \cdot S_{base} \quad (4-27)$$

where  $S_{base}$  is the section modulus of the pile at the new ground line. Recall that the bending strength of timber is assumed as 12.0 ksi for the purposes of the screening tool. Following this analysis and applying the 1.33 factor of safety, Equation 4-23 was rewritten in the following manner:

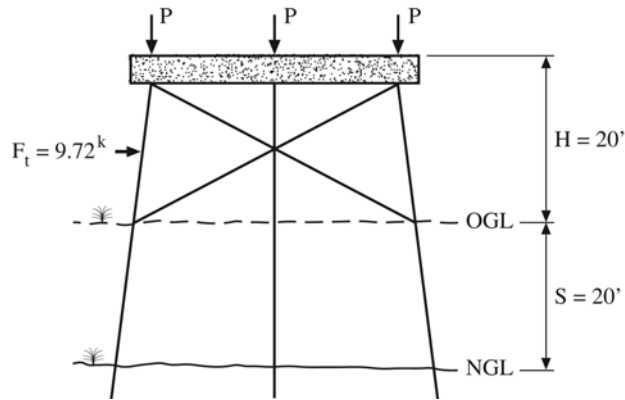
$$\frac{P_{load}}{P_{cr}} + \frac{M_{Max}}{M_{rupture}} \leq 0.75 \quad (4-28)$$

Multiple bent geometries were considered in order to determine the critical scour leading to beam-column failure. The larger debris raft force was initially used for the analysis. If a pile was deemed safe after applying the larger force, it was automatically deemed safe for the smaller raft force. If the pile was found unsafe for the larger raft, the smaller raft force case was then investigated. Note that the unfactored raft loads, 6.48 kips and 9.72 kips, were used in the analysis since a factor of safety is applied in the interaction equation.

#### **4.6.2 Analysis of Braced Bents**

The assumed maximum possible scour and the minimum scour (none) were investigated for the tallest and heaviest-loaded braced bent considered in the screening

tool. The analyses for a 20 foot, 3-pile, 12 inch pile diameter bent with a 60 kip load and 20 feet of scour may be seen in Figure 4.17 (and in Appendix C). This is the tallest braced bent height that is considered in the screening tool, as well as the heaviest gravity loading and maximum considered scour value. Note that the pile is determined to be safe; therefore all braced timber bents are considered safe from beam-column failure for the screening tool. The extra stiffness provided by the bracing is effective for stability; hence it is recommended that all newly-constructed timber bents be cross-braced.



From the moment diagram:

$$M_{F_t} = \frac{13}{64} \cdot 9.72 \text{ kips} \cdot 16 \text{ ft} = 31.6 \text{ kip} \cdot \text{ft} = M_{\text{Max}} \quad M_{\text{HB}} = \frac{3}{32} \cdot 9.72 \text{ kips} \cdot 16 \text{ ft} = 14.6 \text{ kip} \cdot \text{ft}$$

Checking at the location of debris raft force  $F_t$ :

$$d_{F_t} = 12 \text{ in} - \left( 8.5 \text{ ft} \cdot 0.12 \frac{\text{in}}{\text{ft}} \right) = 10.98 \text{ in} \quad A_{F_t} = \frac{\pi \cdot (10.98 \text{ in})^2}{4} = 94.7 \text{ in}^2$$

$$S_{F_t} = \frac{\pi \cdot (10.98 \text{ in})^3}{32} = 130 \text{ in}^3$$

Checking at horizontal brace using effective section properties:

$$d_{\text{eff}} = 12 \text{ in} - \left( 25.83 \text{ ft} \cdot 0.12 \frac{\text{in}}{\text{ft}} \right) = 8.90 \text{ in} \quad I_{\text{eff}} = \frac{\pi \cdot (8.90 \text{ in})^4}{64} = 308 \text{ in}^4$$

Also must check  $P_{\text{cr}}$  for buckling in unbraced region exposed due to scour:

$$P_{\text{cr}} = \frac{2 \cdot \pi^2 \cdot E \cdot I_{\text{eff}}}{L^2} = \frac{2 \cdot \pi^2 \cdot 1800 \text{ ksi} \cdot 308 \text{ in}^4}{(21.5 \text{ ft} \cdot 12)^2} = 168.3 \text{ kips}$$

Recall,

$$\sigma_{\text{rupture}} = 12.0 \text{ ksi} \quad \rightarrow \quad M_{\text{rupture}} = \sigma_{\text{rupture}} \cdot S_{F_t} = 12 \text{ ksi} \cdot 97.8 \cdot \text{in}^3 = 97.8 \text{ kip} \cdot \text{ft}$$

$$\sigma_{\text{crushing}} = 7.0 \text{ ksi} \quad \rightarrow \quad P_{\text{crushing}} = \sigma_{\text{crushing}} \cdot A_{F_t} = 7 \text{ ksi} \cdot 94.7 \cdot \text{in}^2 = 662.9 \text{ kips}$$

Therefore section is controlled by buckling, rather than crushing.

$$\frac{P_{\text{axial}}}{P_{\text{cr}}} + \frac{M_{\text{Max}}}{M_{\text{rupture}}} = \frac{60 \cdot \text{kips}}{168.3 \cdot \text{kips}} + \frac{31.6 \cdot \text{kip} \cdot \text{ft}}{97.8 \cdot \text{kip} \cdot \text{ft}} = 0.35 + 0.32 = 0.67 < 0.75 \rightarrow \text{OK!}$$

**Figure 4.17 Beam-Column Analysis for 3-Pile Braced Bent (Bent Height = 20 ft, Scour = 20 ft, Pile Butt Diameter = 12 in.)**

### 4.6.3 Analysis of Unbraced Bents

It was necessary to analyze multiple cases to determine the critical scour for unbraced piles considered as beam-columns. The results of all the beam-column analyses are summarized in Table 4.14. The maximum gravity load,  $P_{allow}$ , that can be applied to the pile without beam-column failure is shown in the rightmost column. A “FAIL” designation means the pile is unstable as a beam-column without any gravity load.

**Table 4.14 Beam-Column Analysis Evaluations for Multiple Bent Geometries**

Braced Cases				
Bent Height (ft)	Pile Butt Diameter (in.)	Scour Depth (ft)	Raft Force (kips)	$P_{allow}$ (kips)
20	12	20	9.72	60
Unbraced Cases				
Bent Height (ft)	Pile Butt Diameter (in.)	Scour Depth (ft)	Raft Force (kips)	$P_{max}$ (kips)
8	12	5	9.72	60
	12	10	9.72	FAIL
	14	10	9.72	60
	12	10	6.48	26
12	12	0	9.72	60
	12	5	9.72	20
	14	5	9.72	60
	12	5	6.48	32
	12	10	9.27	8.3
	14	10	9.72	36
	14	10	6.48	44
	12	15	9.72	FAIL
14	15	9.72	FAIL	

The calculation of all considered cases may be seen in Appendix C.

Investigations were limited to unbraced bents less than 12 feet in height and scour

values less than 15 feet. Because all unbraced bents failed in the beam-column mode at 15 feet of scour, it was not necessary to investigate greater depths. If unbraced bents with a height greater than 12 feet are encountered, the engineer may determine beam-column adequacy by following the procedure shown in Appendix C using the pertinent geometry.

## CHAPTER 5

### SCREENING TOOL FLOWCHARTS

#### 5.1 General

A more global perspective of the investigative process is useful to understand the screening tool. Flowcharts are included in the chapter to better inform the user of the most important calculations needed to determine adequacy and the order these calculations will be conducted in the automated screening tool.

#### 5.2 Screening Tool Macro-Flowchart

A macro-flowchart (seen in Figure 5.1) is first included to highlight the five possible failure modes and their order of investigation in the screening tool.

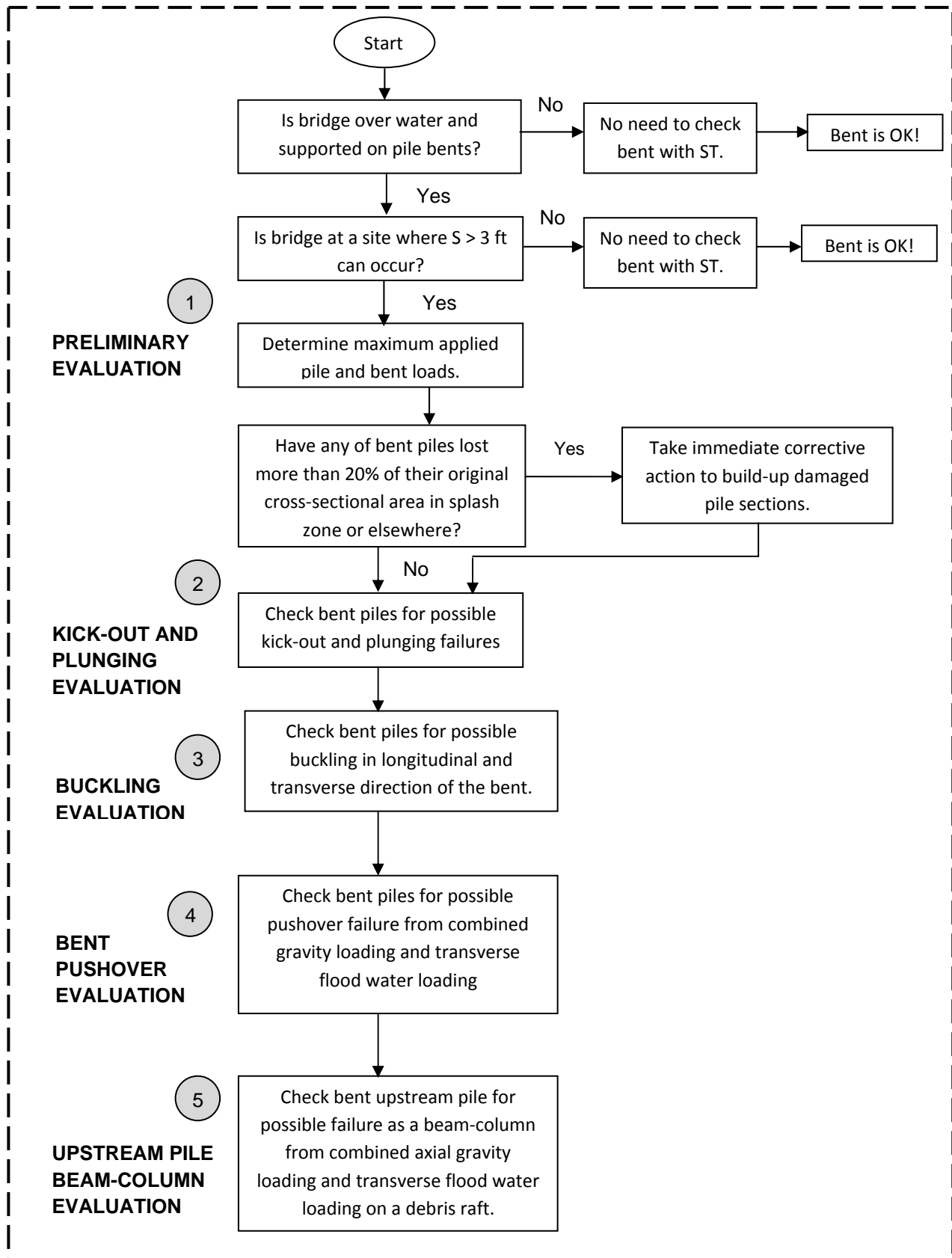


Figure 5.1 Screening Tool (ST) Macro-Flowchart



### **5.3 Screening Tool Micro-Flowcharts**

Micro-flowcharts detailing the procedure for checking each failure mode are included in this section. A schematic of all the flowcharts is shown in Figure 5.2, while enlargements of each of the five major blocks of the screening tool are shown in Figures 5.3 through 5.7 for easier reading.

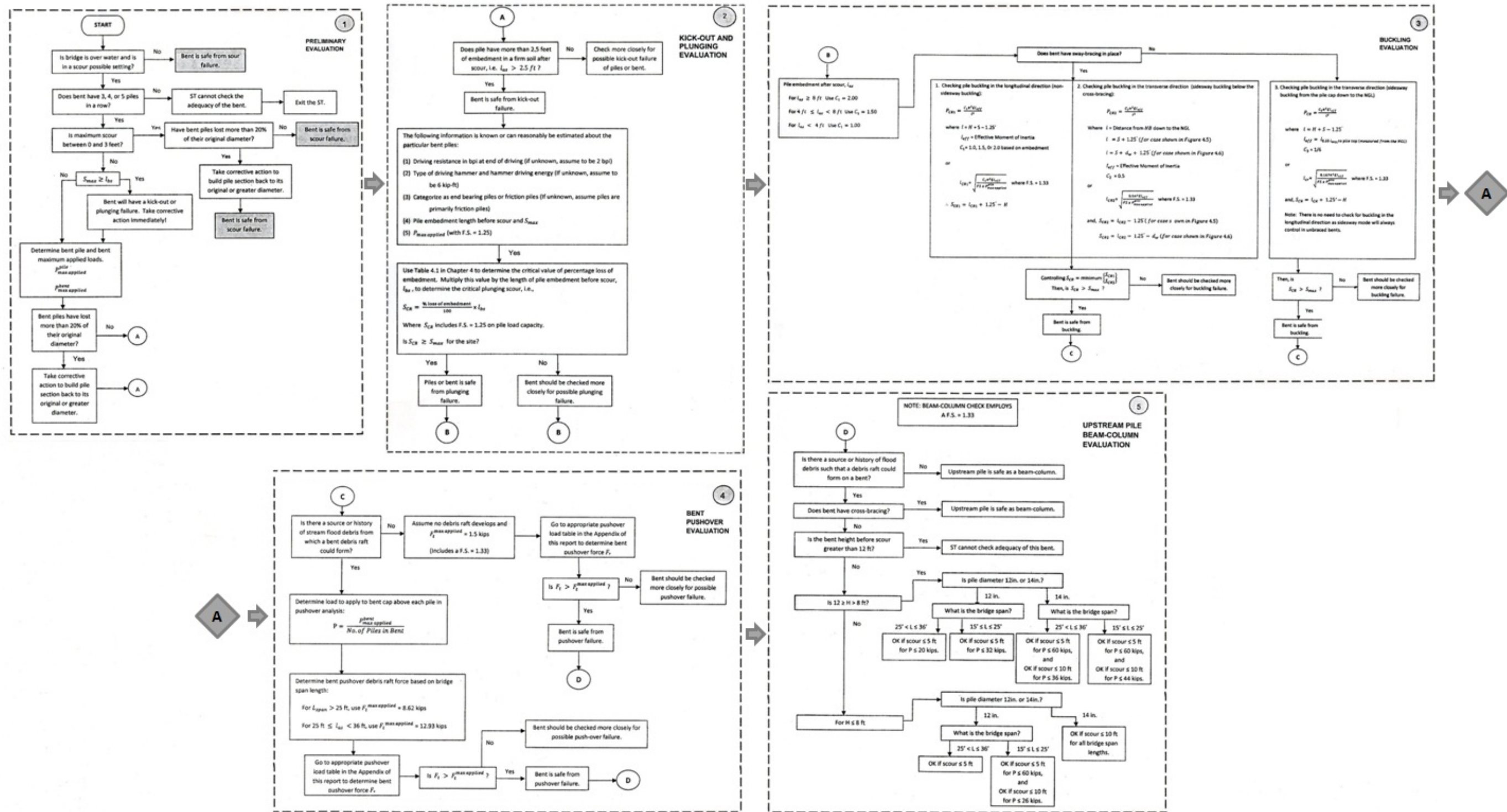
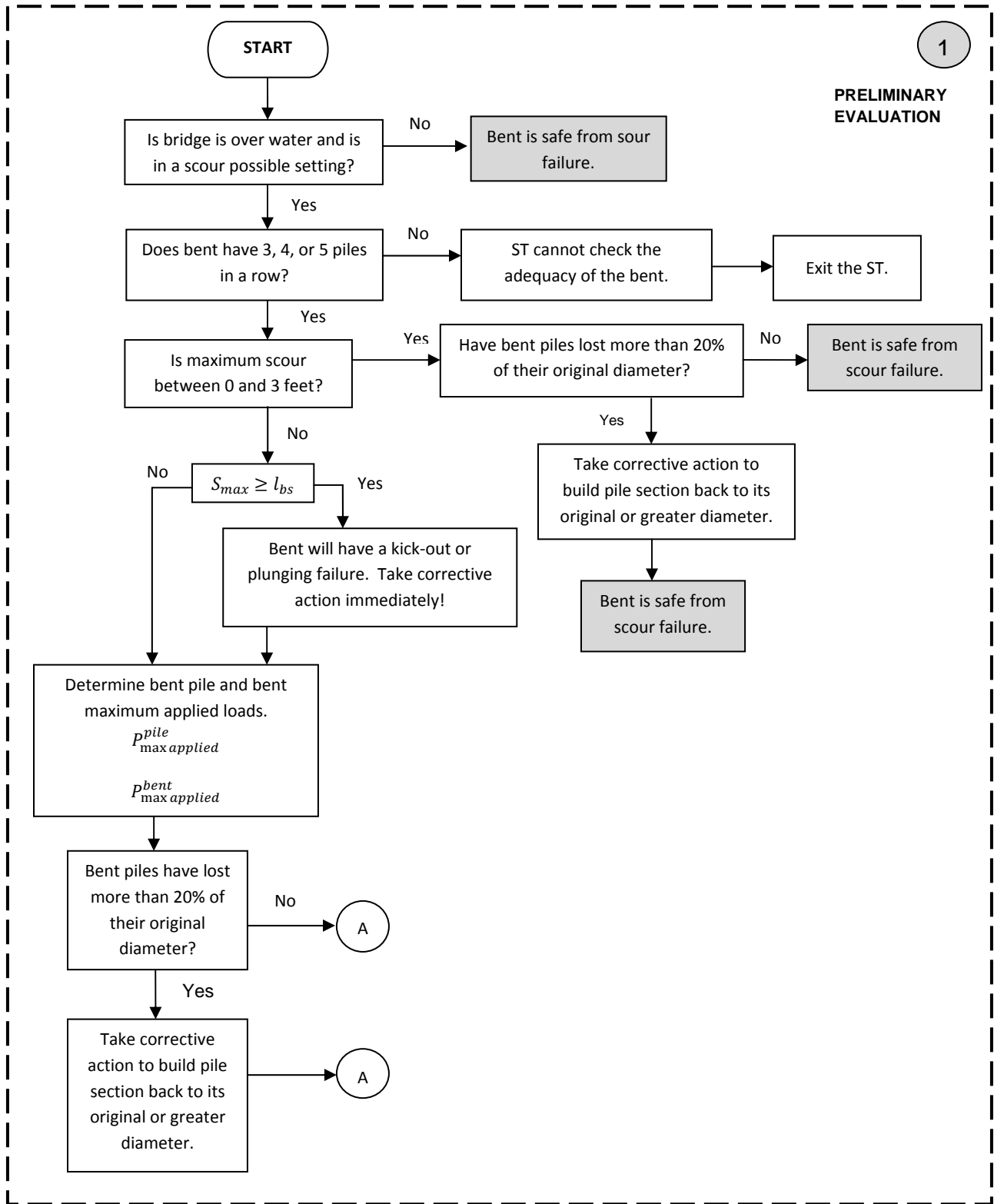
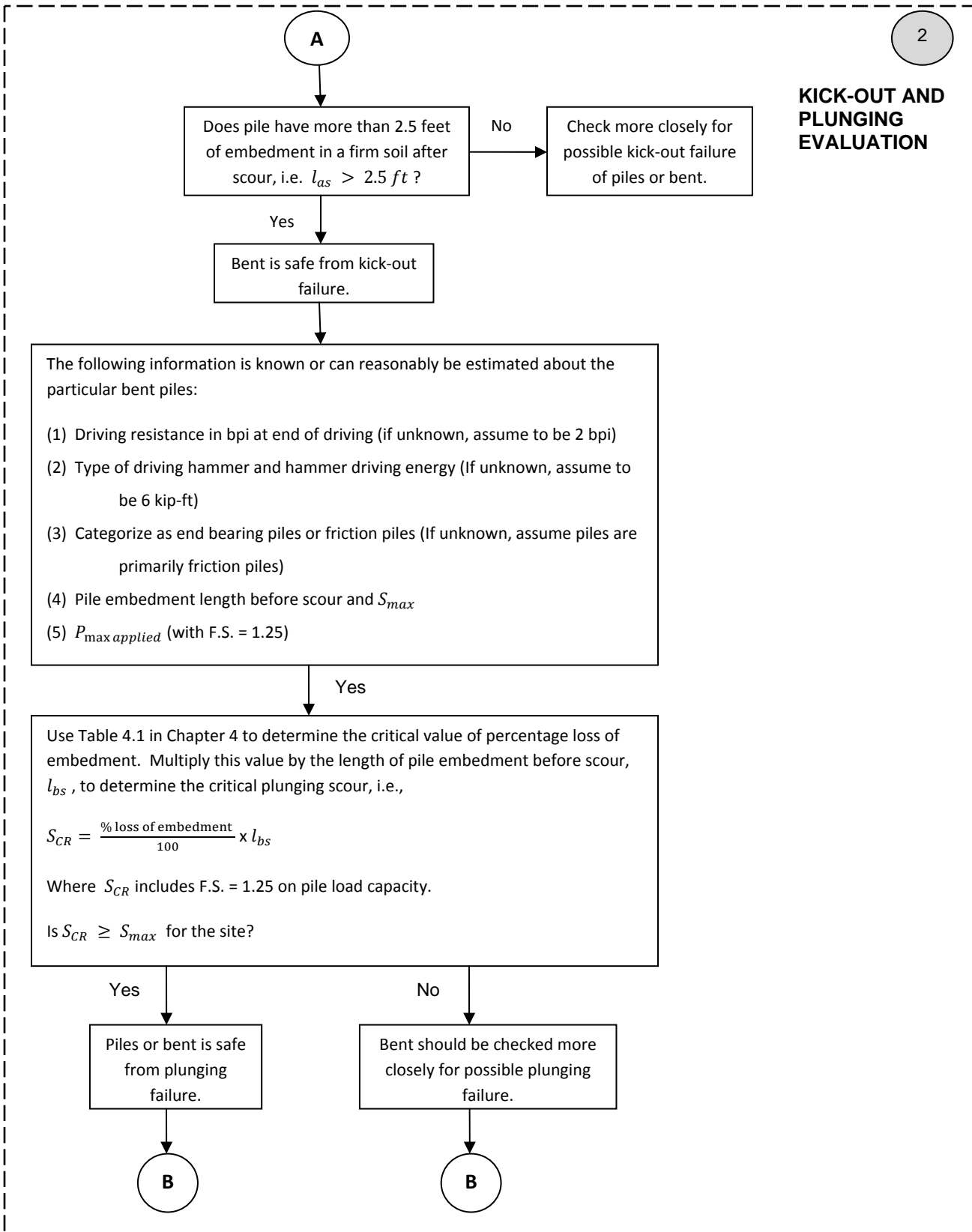


Figure 5.2 Screening Tool Micro-Flowchart Schematic



**Figure 5.3 Screening Tool Flowchart Block 1 – Preliminary Evaluation**

**KICK-OUT AND  
PLUNGING  
EVALUATION**

**Figure 5.4 Screening Tool Flowchart Block 2 – Kick-out and Plunging Evaluation**

**BUCKLING EVALUATION**

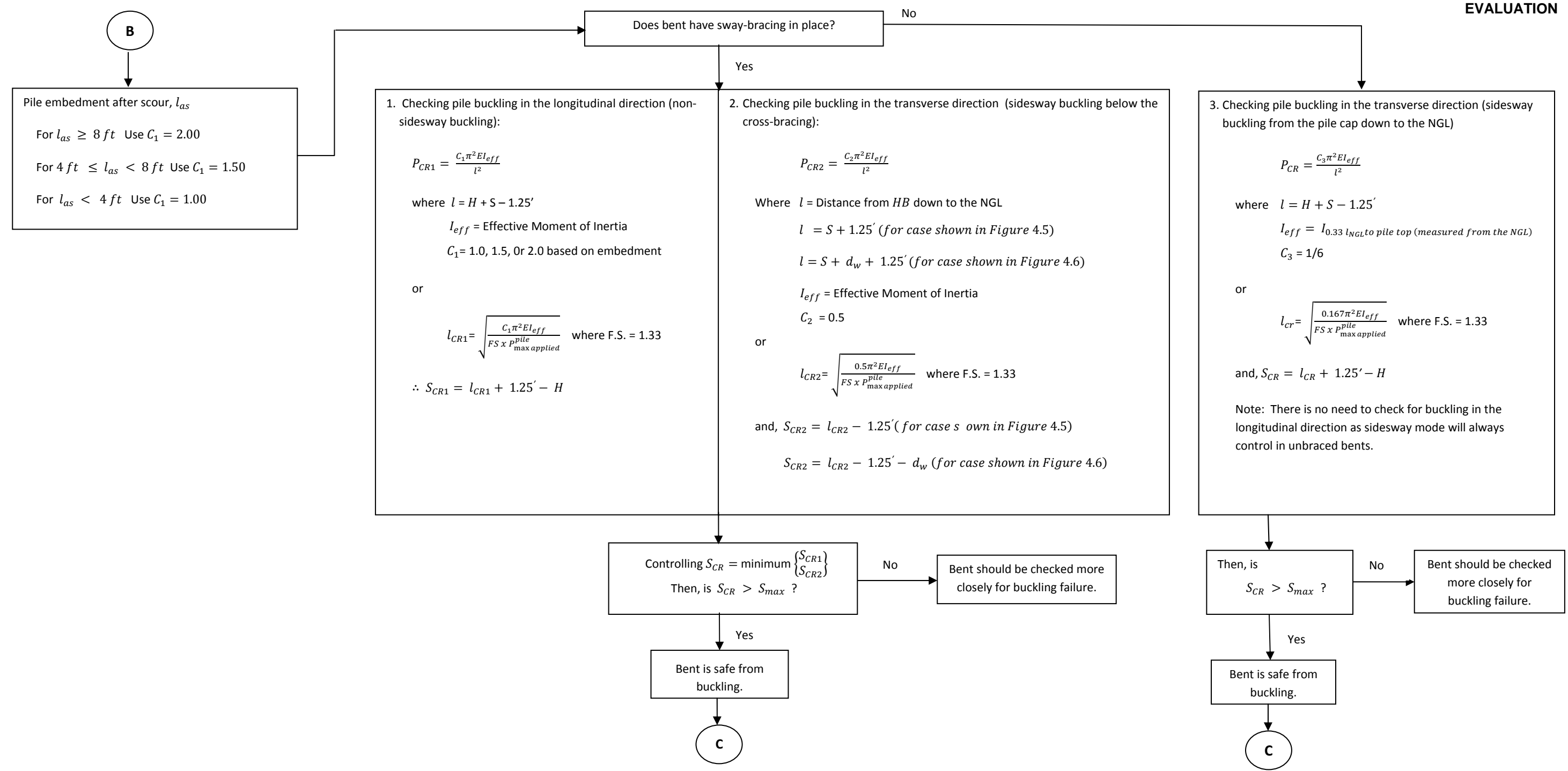
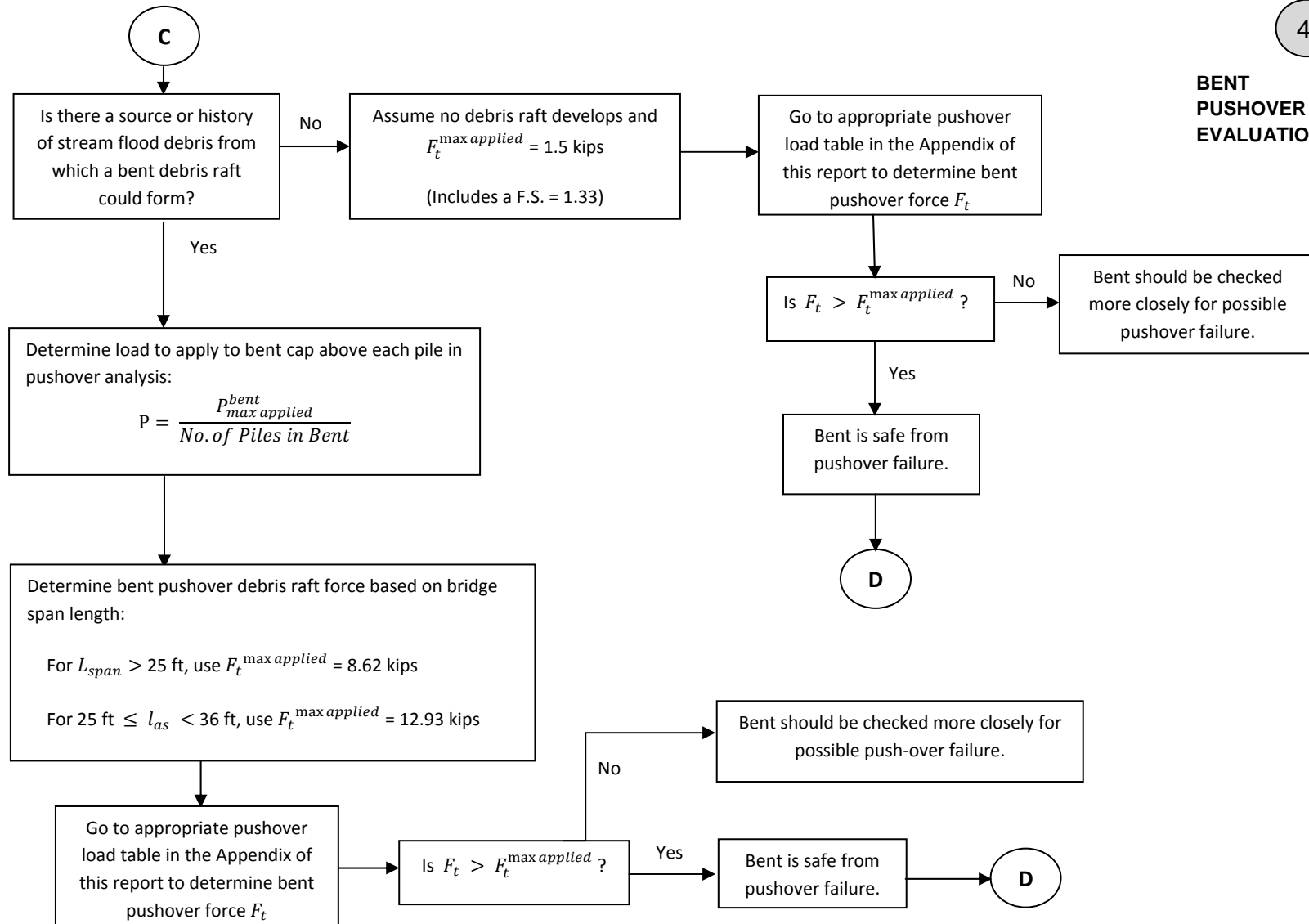
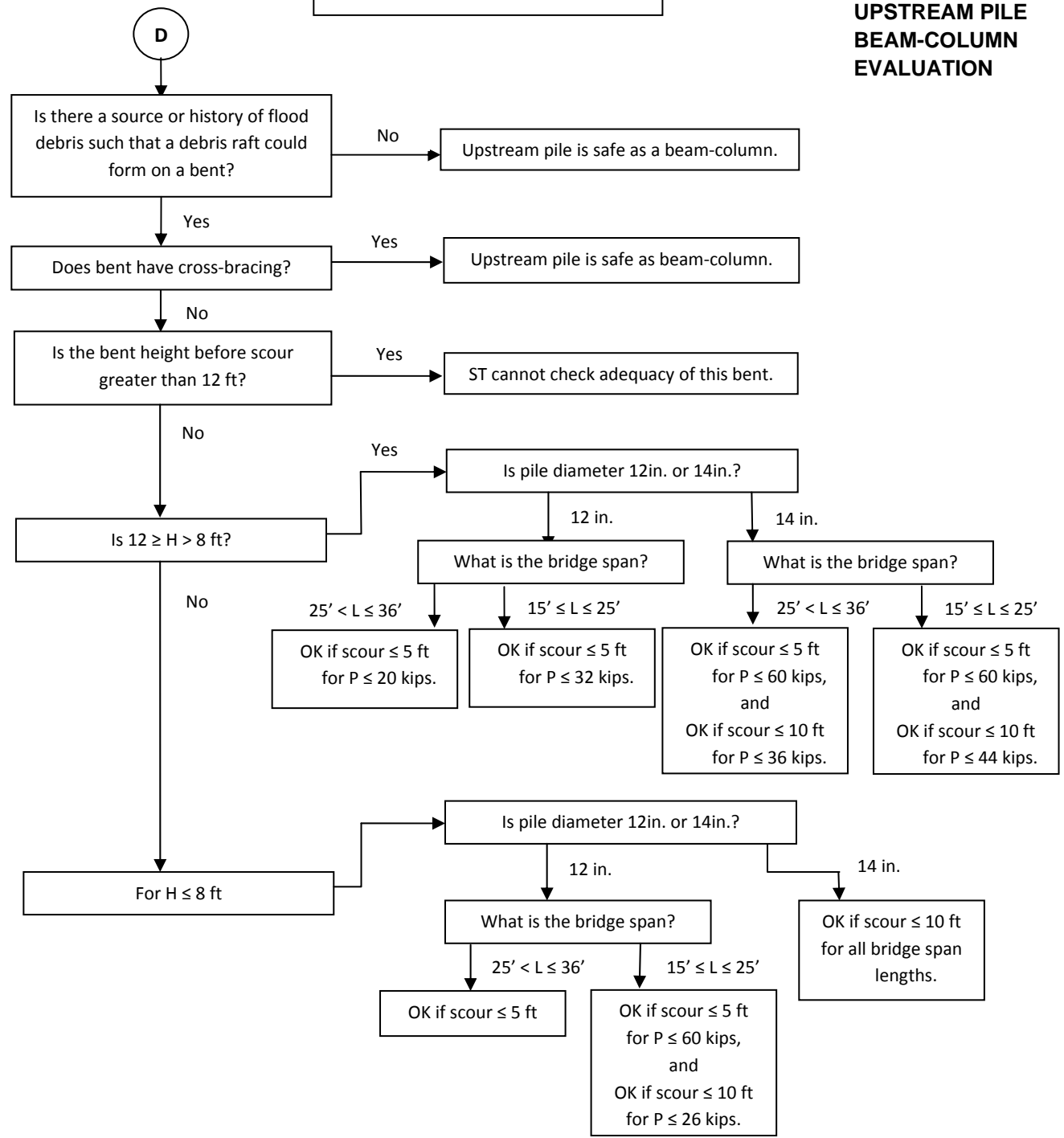


Figure 5.5 Screening Tool Flowchart Block 3 – Buckling Evaluation

**BENT  
PUSHOVER  
EVALUATION**

**Figure 5.6 Screening Tool Flowchart Block 4 – Bent Pushover Evaluation**

NOTE: BEAM-COLUMN CHECK EMPLOYS  
A F.S. = 1.33

**UPSTREAM PILE  
BEAM-COLUMN  
EVALUATION**



**Figure 5.7 Screening Tool Flowchart Block 5 – Upstream Beam-Column Evaluation**

## CHAPTER 6

### AUTOMATION OF THE SCREENING TOOL USING VISUAL STUDIO

#### 6.1 General

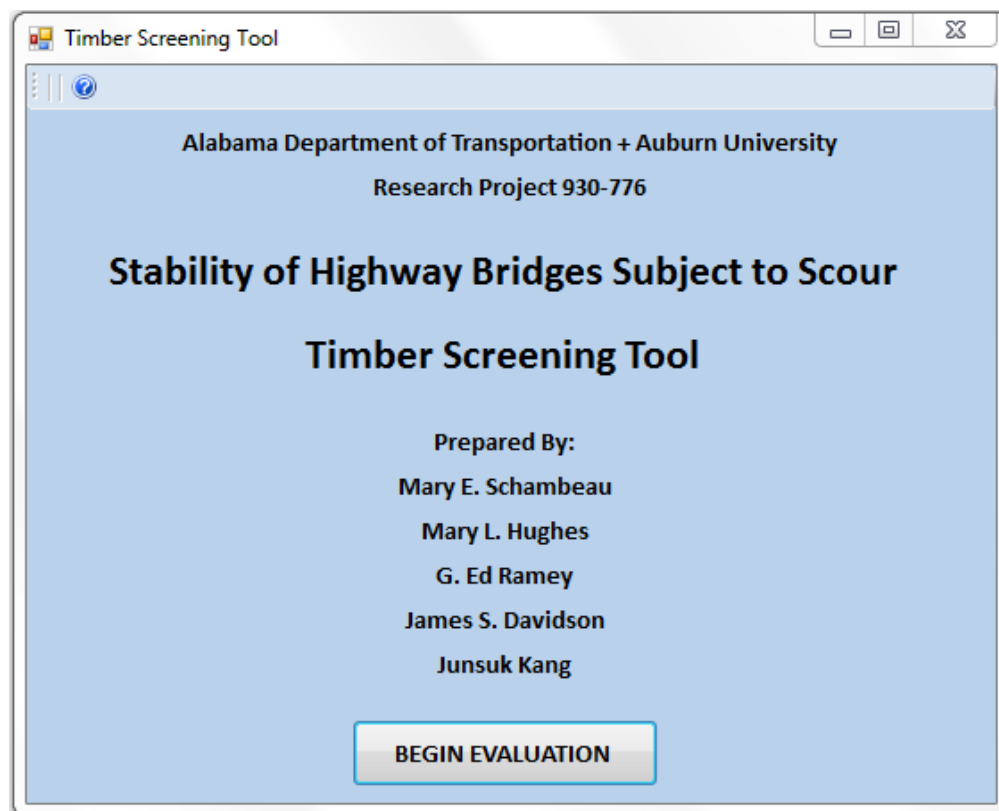
The analyses used to produce the manual screening tool provided the framework for the computer code used to produce an automated screening tool. This automation was accomplished using Microsoft Visual Studio 2005 and Microsoft Visual Studio 2010 with Visual Basic (VBA) computer code. The entire VBA code for the automated screening tool can be seen in Appendix D. Pertinent code subsections in the appendix will be cited when necessary for each evaluation. This chapter describes the operation of the automated screening tool, highlighting the assumptions and simplifications used in the automated screening tool. The tool uses a series of forms to gather input from the user and then displays the results in subsequent forms. An example problem for a braced timber pile bent will be used to illustrate the tool and the forms in this chapter. It is the same example that was used in the Phase I report (Ramey et al. 2011) for the evaluation of a braced bent using the manual screening tool.

Before using the screening tool, users should familiarize themselves with this chapter. Improper input may produce results, but the results will be erroneous. An understanding of the analysis procedures utilized will enable the user to gauge whether the automated screening tool results are reasonable and credible. The inclusion of a printable output report also provides a means for the user to check whether the desired



input was the input actually used by the program. This output report will be described in detail later in the chapter.

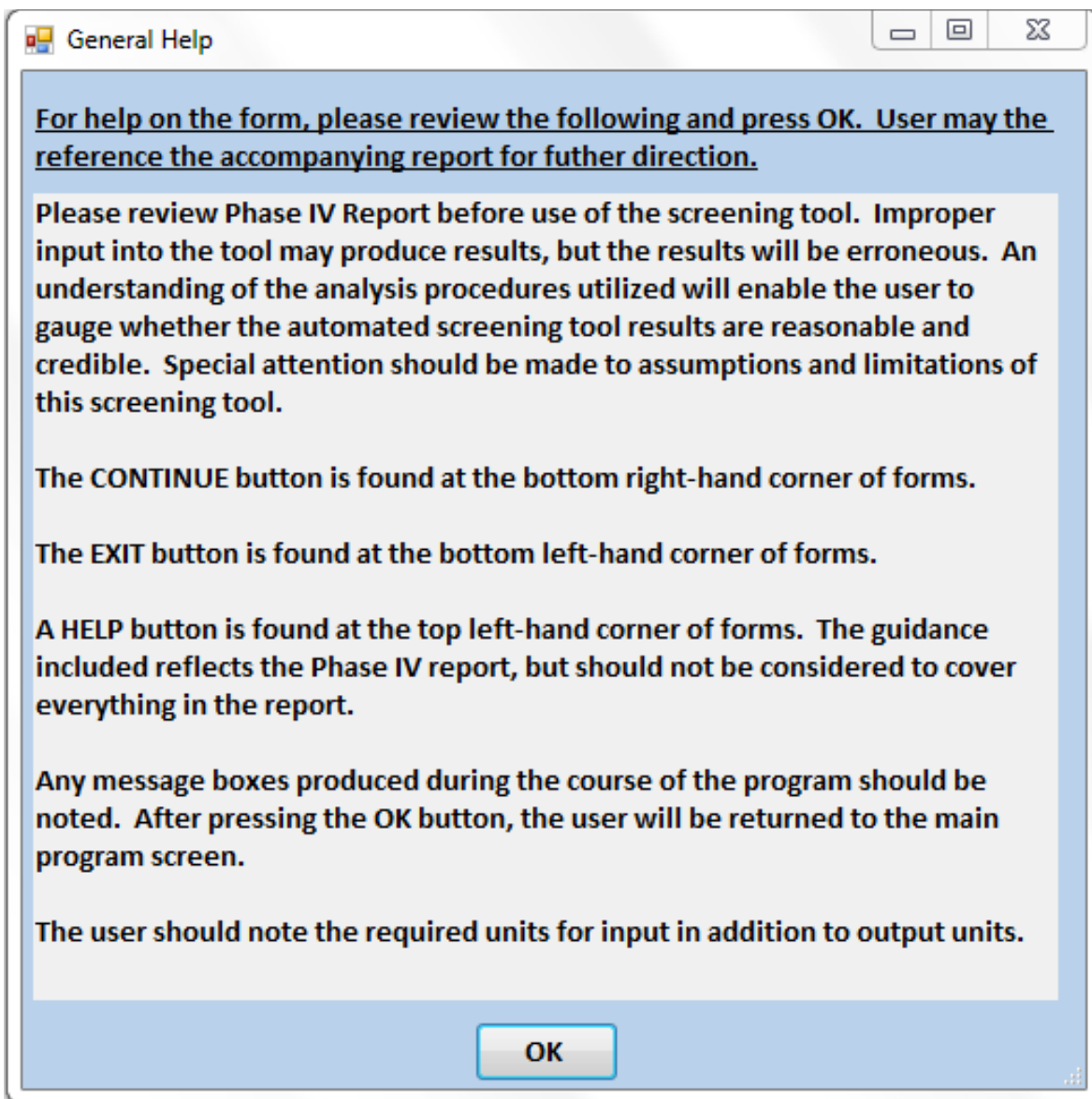
While the program was developed using Visual Studio 2005 and Visual Studio 2010, the screening tool can be accessed through an executable program that does not use Visual Studio as its platform. Opening the “TimberScour” application file will launch the tool on any computer that has the “TimberScour” parent folder. The opening form is shown in Figure 6.1. The button at the center of the form marked “BEGIN EVALUATION” is first pushed to start the evaluation process.



**Figure 6.1 Opening Form for Timber Stability Tool**

Buttons such as this are used throughout to signal to the program that the user has completed the directions and is ready to advance to the next form. A continue (CONTINUE) button is found at the bottom right-hand corner of all subsequent forms.

Note that the exit (EXIT) button can be also pressed at any moment during the program, closing all forms. This button can be found in the bottom left-hand corner of each form. A help (HELP) icon, indicated by a blue question mark, can also be found in the toolbar located at the top of some forms. The help icon shown in Figure 6.1 will display the dialog box shown in Figure 6.2.



**Figure 6.2 General Help Dialog Box**

The guidance included in HELP dialog boxes reflects the Phase IV report, but should not be considered to cover the entire report. The most important assumptions and advice are included. HELP dialog boxes are to be closed using the OK button found at the bottom of the window. The program will not proceed until the HELP window is closed.

## **6.2 Preliminary Input Analysis**

The preliminary evaluation form is used to gather all required input needed to run the screening tool. Also, kick-out susceptibility and section loss issues are determined.

Input parameters include the following:

- (1) Whether or not bridge is in a scour possible setting,
- (2) Span lengths between consecutive bents of the bridge,
- (3) Number of piles in a bent,
- (4) Height of the bent (measured from the top of the cap to the OGL),
- (5) Water depth below bent,
- (6) Pile butt diameter,
- (7) Bracing condition,
- (8) Pile embedment length,
- (9) Estimated depth of maximum scour,
- (10) Presence or non-presence of significant marine borer or rotting issues.

All required information must be included for subsequent calculations. The number of piles in the bent, pile diameter, and bracing scheme are chosen by drop-down menus. Because this is a screening tool, only broad cases of pile diameter and number of piles were considered. Note, one-story bracing is assumed. While occasional instances of

two-story bracing were reported by ALDOT, one-story bracing is a conservative assumption. See the discussion in Section 3.4. The user should note the required units for all properties. If a bent is not over water, user should input “0” for the depth of water under the bent as indicated on the form. The preliminary analysis form is shown in Figure 6.3.

**Preliminary Evaluation**

Please answer the following questions concerning the bridge environment.

Is the bridge under assesment over water or in a possible scour environment?  YES  NO

Is the formation of a debris raft possible?  YES  NO

Is the bridge supported by timber pile bents?  YES  NO

Span of the bridge between consecutive bents (ft) 36 ft

Please provide the following information pertaining to the critical bent under evaluation.

Number of piles in the the critical bent 4

Height of critical bent before scour, H (ft) 16 ft

Depth of water under bent (if not over water, use 0) (ft) 0 ft

Critical Pile Butt Diameter, d (in) 12 in

Bracing Scheme X-Braced

Length of critical pile embedment in soil BEFORE scour, Lbs (ft) 24 ft

Maximum estimated scour at critical bent, Smax (ft) 15 ft

Has criticial pile lost more than 20% of pile diameter at splash zone due to rotting or marine borers?  YES  NO

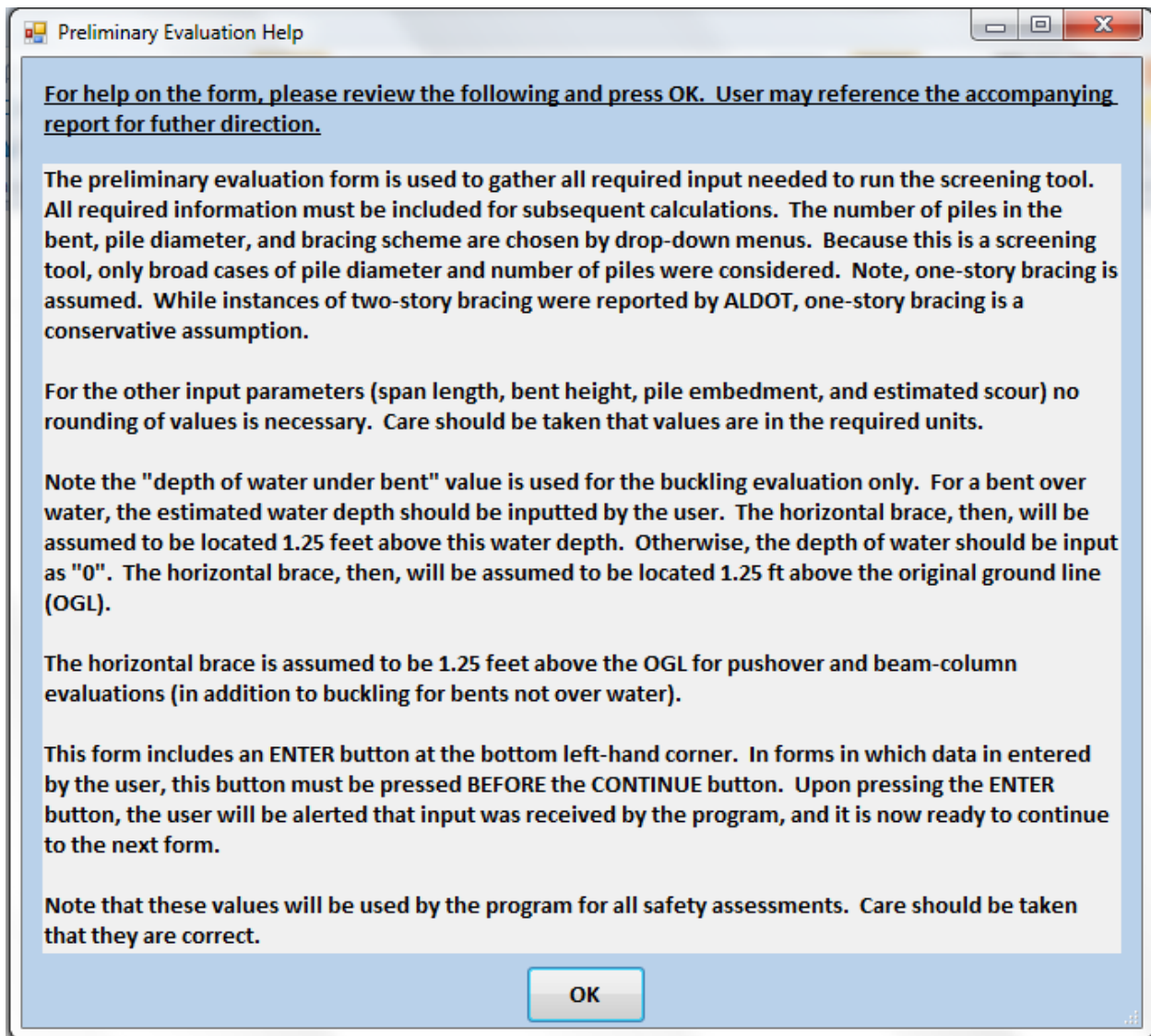
EXIT Input received! Continue to the next stage of evaluation. CONTINUE

**Figure 6.3 Preliminary Evaluation Form**

For this example, a 16 foot high, 4-pile timber braced bent is used. The bent is not over water, therefore the depth of water under the bent is 0 feet. The span between bents is 36 feet (therefore the larger debris raft will accumulate). The critical pile butt diameter is

12 inches. The length of embedment before scour is 24 feet. 15 feet of scour is projected at the site. No section loss has been reported.

If the HELP icon is pressed in the toolbar of the Preliminary Evaluation form the dialog box shown in Figure 6.4 will appear.



**Figure 6.4 Preliminary Evaluation Help Dialog Box**

Once all questions have been answered by the user, the enter (ENTER) button should be pressed as indicated by the large green arrow on the form. If any textbox or drop-down menu is left blank, subsequent calculations should be considered erroneous.

After pressing the ENTER button, the user will either be directed to continue to the next stage of evaluation or given a message box. This message box, or boxes, will display important information that must be noted by the user. If input parameters are outside the scope of the screening tool, the user will be alerted by a message box in the center of the screen and advised to exit the screening tool. If marine borer or rot issues have led to substantial section loss, the user will be advised to build the section back up to its original diameter in this message box. Remember, all calculations will use this original diameter, therefore all failure modes later designated as safe are contingent on the pile being built back to its original diameter. An example of the critical section loss message box can be seen below in Figure 6.5.

The screenshot shows a software window titled "Preliminary Evaluation" with a light blue background. The main form contains several questions and input fields:

- Is the bridge under assesment over water or in a possible scour environment?** YES (selected) NO
- Is the formation of a debris raft possible?** YES (selected) NO
- Is the bridge supported by timber pile bents?** YES (selected) NO
- Span of the bridge between consecutive bents (ft)** 36 ft
- Please provide the following information pertaining to the critical bent under evaluation.**
- Number of piles in the the critical bent** 4
- Height of critical bent** 16 ft
- Depth of water under** 0 ft
- Critical Pile Butt Diam** 12 in
- Bracing Scheme** X-Braced
- Length of critical pile embedment in soil BEFORE SCOUR, L<sub>DS</sub> (ft)** 24 ft
- Maximum estimated scour at critical bent, S<sub>max</sub> (ft)** 15 ft
- Has critcial pile lost more than 20% of pile diameter at splash zone due to rotting or marine borers?** YES (selected) NO

A dialog box titled "TimberScour" is overlaid in the center, containing the text: "Corrective action should be taken to build pile section to original or greater diameter." and an "OK" button. A green arrow points to the "ENTER" button at the bottom right of the main form.

Figure 6.5 Example Critical Section Loss Alert Dialog Box

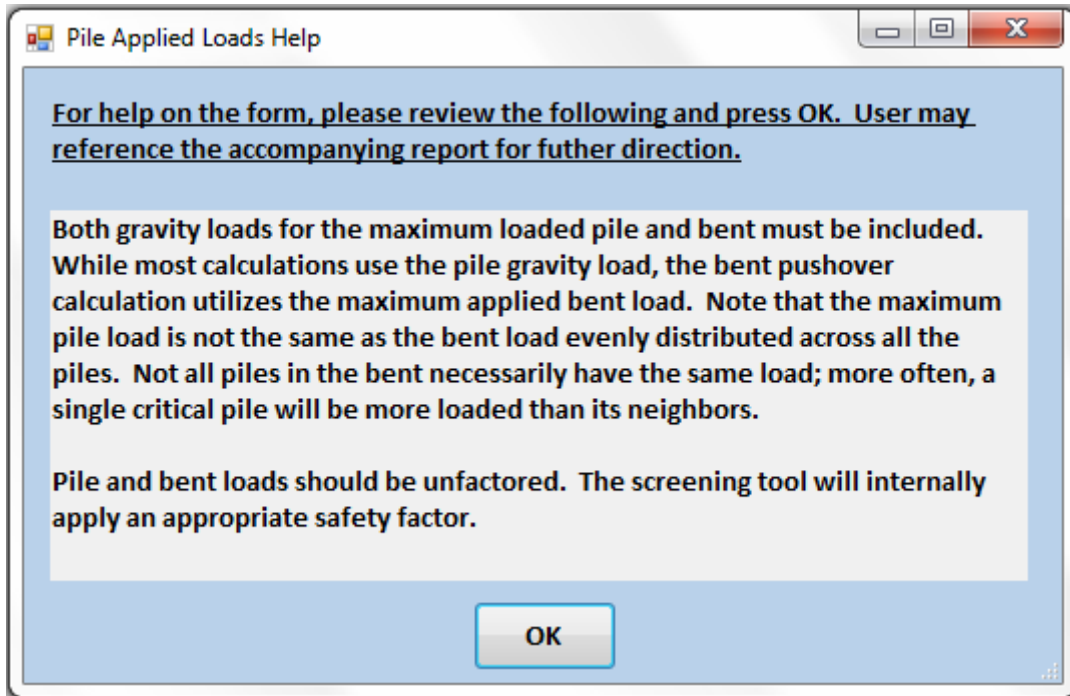
After all dialog boxes have been addressed and closed by pressing the (OK) button, the user will be directed to press the continue (CONTINUE) button by the large green arrow on the form. This will open the next form which is used to input the maximum applied pile and bent loads. For this example, the maximum pile applied load is 40 kips, while the maximum bent applied load is 160 kips. The form can be seen below in Figure 6.6.

The screenshot shows a software dialog box titled "Maximum P-Load Evaluation". The dialog has a light blue background and a standard Windows-style title bar with minimize, maximize, and close buttons. The main content area contains the following elements:

- A heading: **Please provide the maximum applied bent and pile loads.**
- Two input fields:
  - Label: **Maximum Pile Applied Load (Unfactored), kips**. Value:  kips
  - Label: **Maximum Bent Applied Load (Unfactored), kips**. Value:  kips
- A button labeled **ENTER** positioned below the second input field.
- At the bottom, a status bar area containing:
  - An **EXIT** button on the left.
  - Text: **Input received! Continue to the next stage of evaluation.**
  - A large green arrow pointing to the right.
  - A **CONTINUE** button on the right.

**Figure 6.6 Input Form for Maximum Pile and Bent Loads**

Note that the maximum pile load is not necessarily the same as the bent load evenly distributed across all the piles. Not all piles in the bent necessarily have the same load; therefore the maximum single pile load is entered in addition to the total bent load. For detailed description of the calculation of these loads, see Chapter 6 of the Phase IV Milestone No. 1 Report (Ramey et al. 2011). Note that loads should be entered as unfactored loads and in units of kips. The HELP dialog box found in the form's toolbar reminds the user of these stipulations. It can also be seen in Figure 6.7.



**Figure 6.7 Pile and Bent Applied Loads Help Dialog Box**

In the steel screening tool, a load calculator was included to compute pile and bent maximum applied loads. While this timber screening tool does not include such a calculator, the steel screening tool calculator could still be used to determine maximum load. However, the engineer would have to determine equivalent loads to describe the weight of the timber bent bridge superstructure in order to do so. After entering these loads, the user is directed to continue to the next form.

### **6.3 Kick-out and Plunging Evaluation**

The next form gathers data used to evaluate plunging and kick-out susceptibility of the bent. For plunging evaluation, geometry for multiple piles may be entered rather than for only the critical pile. The information for each pile is assigned to a single column. Not all columns are required to be filled and the user may only input the most critical pile in a single column if preferred. In this case, all columns of data are inputted



as shown in Figure 6.8.

**Kick-out and Plunging Evaluation**

Please enter all input information below for kick-out and plunging evaluation, then press ENTER.

Hammer Type

Pile Number	<input type="text" value="1"/>	<input type="text" value="6"/>	<input type="text" value="7"/>	<input type="text" value="8"/>	<input type="text" value="9"/>
Driving Resistance (blow/in.)	<input type="text" value="5"/>	<input type="text" value="5.5"/>	<input type="text" value="5"/>	<input type="text" value="4.3"/>	<input type="text" value="5"/>
Hammer Energy (ft-lbs)	<input type="text" value="12000"/>	<input type="text" value="11500"/>	<input type="text" value="11000"/>	<input type="text" value="12000"/>	<input type="text" value="12000"/>
Maximum Scour (ft)	<input type="text" value="15"/>	<input type="text" value="10"/>	<input type="text" value="10"/>	<input type="text" value="12"/>	<input type="text" value="12"/>
Length of Embedment BEFORE Scour, Lbg (ft)	<input type="text" value="24"/>	<input type="text" value="24"/>	<input type="text" value="24"/>	<input type="text" value="24"/>	<input type="text" value="24"/>

Plunging evaluation output shown below.

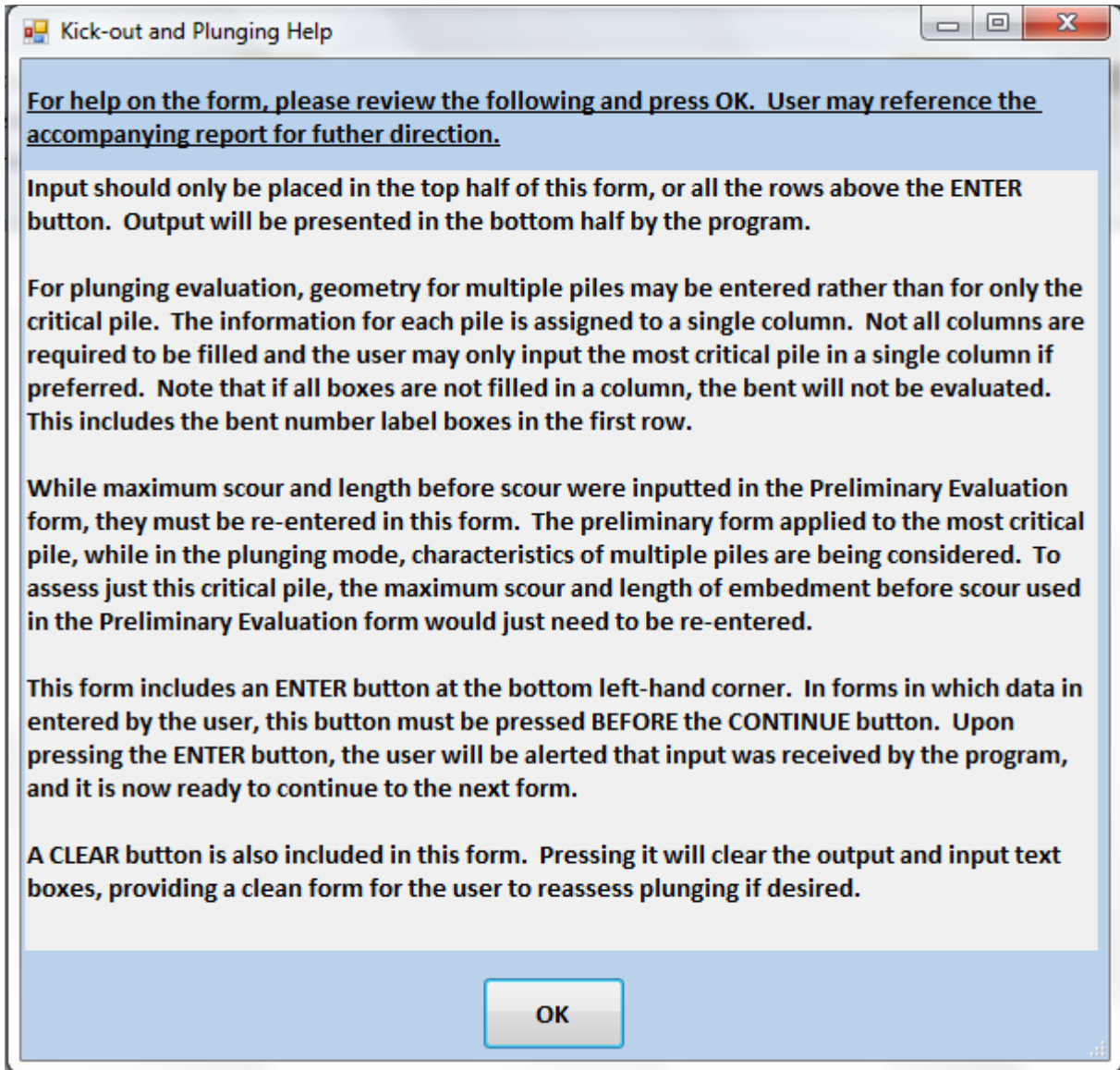
End Bearing Capacity (tons)	<input type="text"/>	<input type="text"/>	<input type="text"/>	<input type="text"/>	<input type="text"/>
End Bearing Critical Scour (ft)	<input type="text"/>	<input type="text"/>	<input type="text"/>	<input type="text"/>	<input type="text"/>
End Bearing Safety	<input type="text"/>	<input type="text"/>	<input type="text"/>	<input type="text"/>	<input type="text"/>
Friction Pile Capacity (tons)	<input type="text"/>	<input type="text"/>	<input type="text"/>	<input type="text"/>	<input type="text"/>
Friction Pile Critical Scour (ft)	<input type="text"/>	<input type="text"/>	<input type="text"/>	<input type="text"/>	<input type="text"/>
Friction Pile Safety	<input type="text"/>	<input type="text"/>	<input type="text"/>	<input type="text"/>	<input type="text"/>

Maximum Applied Pile Load, tons

**Figure 6.8 Plunging Evaluation Form Showing Input**

The pile-driving hammer type is chosen from a drop-down box at the top of the form (in this case, a drop hammer). Values of driving resistance, hammer energy, maximum estimated scour depth, and embedment before scour are provided by the user. The most critical pile is located in Column 1 (driving resistance = 5 bpi, hammer energy = 12,000 ft-lbs, maximum scour = 15 feet, and embedment before scour = 24 feet). Note

that the hammer's rated energy should be inputted into the form. The screening tool will internally apply a reduction based on the efficiency of that hammer. Note that if all boxes are not filled in a column, the bent will not be evaluated. This includes the pile number label boxes. If the user requires any guidance on the form, the HELP icon will display the dialog box shown in Figure 6.9.



**Figure 6.9 Plunging Help Dialog Box**

Recall that dialog boxes are closed by pressing the OK button. After characteristics for all desired piles have been inputted, the ENTER button is pressed. The user will first be alerted of the kick-out failure evaluation with either a dialog box alerting the user to all piles being safe (Figure 6.10), or a series of dialog boxes indicating which piles are either unsafe or in danger of being unsafe after multiple scour events (Figure 6.11). Recall from Section 4.2 that the critical scour depth for imminent kick-out is 2.5 feet, but the critical scour depth for possible danger for future scour events is 5.0 feet.

Please enter all input information below for kick-out and plunging evaluation, then press ENTER.

Hammer Type: Drop Hammer (Assumed 50% Efficient)

Pile Number	1	6	7	8	9
Driving Resistance (blow/in.)	5	5.5	5	4.3	5
Hammer Energy (ft-lbs)	12000	11500	11000	12000	12000
Maximum Scour (ft)	15	10	10	12	12
Length of Embedment BEFORE Scour, Lbg (ft)	24	24	24	24	24

Plunging evaluation output shown below

End Bearing Capacity (tons)	31.76			33.39	35.83
End Bearing Critical Scour (ft)	31.03			30.49	31.03
End Bearing Safety	SAFE	SAFE	SAFE	SAFE	SAFE
Friction Pile Capacity (tons)	23.62	33.28	30.63	27.32	29.32
Friction Pile Critical Scour (ft)	22.17	22.19	21.74	21.78	22.17
Friction Pile Safety	SAFE	SAFE	SAFE	SAFE	SAFE

Maximum Applied Pile Load, tons: 10.00

Buttons: EXIT, ENTER, CLEAR, CONTINUE

TimberScour dialog box: Piles are safe from kick-out failure. OK

Figure 6.10 Kick-out Evaluation Dialog Box for All Piles Safe

If kick-out failure was imminent, or could possibly become critical after multiple scour events a dialog box such as that is shown in Figure 6.11 would appear. Note that Figure 6.11 is a modified version of the example problem being used in this chapter. Rather, it uses different inputs in an effort to show the different dialog box for instructive purposes. To produce this dialog box, the maximum scour for the pile in Column 1 was increased from 15 feet to 22 feet, resulting in a new length of embedment after scour of 2 feet. Therefore, the length of embedment is less than the critical scour depth (2.5 feet) and kick-out failure is imminent.

**Kick-out and Plunging Evaluation**

Please enter all input information below for kick-out and plunging evaluation, then press ENTER.

Hammer Type: Drop Hammer (Assumed 50% Efficient)

Pile Number	1	6	7	8	9
Driving Resistance (blow/in.)	5	5.5	5	4.3	5
Hammer Energy (ft-lbs)	12000	11500	11000	12000	12000
Maximum Scour (ft)	22	10	10	12	12
Length of Embedment BEFORE Scour, Lbg (ft)	24	24	24	24	24

**Plunging evaluation:**

End Bearing Capacity (tons)					35.83
End Bearing Critical Scour (ft)					31.03
End Bearing Safety	SAFE	SAFE	SAFE	SAFE	SAFE
Friction Pile Capacity (tons)	10.32	33.28	30.63	27.32	29.32
Friction Pile Critical Scour (ft)	22.17	22.19	21.74	21.78	22.17
Friction Pile Safety	SAFE	SAFE	SAFE	SAFE	SAFE

Maximum Applied Pile Load, tons: 10.00

EXIT      Input received! Continue to the next stage of evaluation.      CONTINUE

**TimberScour**

Pile in Column 1 unsafe for kick-out. Take preventative measures such as riprap.

OK

Figure 6.11 Kick-out Evaluation Dialog Box for Certain Piles Unsafe

After closing the kick-out dialog box, or boxes, the plunging evaluation output can be easily seen in the bottom half of the form, as seen in Figure 6.12. Note that the data used to produce Figure 6.12 pertains to the original example problem.

Please enter all input information below for kick-out and plunging evaluation, then press ENTER.

Hammer Type: Drop Hammer (Assumed 50% Efficient)

Pile Number	1	6	7	8	9
Driving Resistance (blow/in.)	5	5.5	5	4.3	5
Hammer Energy (ft-lbs)	12000	11500	11000	12000	12000
Maximum Scour (ft)	15	10	10	12	12
Length of Embedment BEFORE Scour, Lbg (ft)	24	24	24	24	24

Plunging evaluation output shown below.

End Bearing Capacity (tons)	31.76	38.74	35.65	33.39	35.83
End Bearing Critical Scour (ft)	31.03	31.07	30.43	30.49	31.03
End Bearing Safety	SAFE	SAFE	SAFE	SAFE	SAFE
Friction Pile Capacity (tons)	23.62	33.28	30.63	27.32	29.32
Friction Pile Critical Scour (ft)	22.17	22.19	21.74	21.78	22.17
Friction Pile Safety	SAFE	SAFE	SAFE	SAFE	SAFE

Maximum Applied Pile Load, tons: 10.00

EXIT      Input received! Continue to the next stage of evaluation.      CONTINUE

**Figure 6.12 Plunging Evaluation Form Showing Input and Output**

The results regarding safety for both an end-bearing pile and a friction pile are shown. Guidance for determination of whether a pile is considered to have primarily end-bearing action or friction action was given in Section 4.3. The critical depth of scour

is also provided so engineers can consider future scour issues. While all the piles in the example bent are safe as friction piles, the most critical pile is in Column 1. The critical scour for the end-bearing and friction conditions are 22.0 feet and 15.7 feet, respectively. Both critical scour values are greater than the estimated scour (15 feet), therefore the pile is safe in plunging for both conditions.

The maximum applied load given by the user can be seen at the bottom of the form for comparison to the calculated capacities. Both the load and the capacities are shown in units of tons for easy comparison. For a pile to be considered adequate, the maximum applied load should be less than the plunging capacity. If the user wishes to evaluate another bent, the form's input and output data can be removed using the clear (CLEAR) button at the bottom right-hand corner so the new data may be inputted.

#### **6.4 Buckling Evaluation**

No more input is required by the user after continuing from the plunging form. Instead, forms will display the input that was used for the analysis without any action by the user. For this reason, it is of utmost importance for the input of the preliminary analysis forms to be accurate and complete. Buckling evaluation and all subsequent forms will also show important intermediate calculated values in addition to the failure mode safety assessments. The form shown in Figure 6.13 pertains to the buckling evaluation.


**Buckling Evaluation**

The following information was previously determined.

Is bent X-Braced?	X-braced	
Pile Butt Diameter, d (in)	12	in.
Bent Height, H (ft)	16.0	ft
Scour, S (ft)	12.0	ft
Embedment AFTER Scour, Las (ft)	9.0	ft
Max Unfactored Pile Load, kips	40.0	kips

Buckling Analysis Results:

Effective Moment of Inertia, $I_{eff}$ (in <sup>4</sup> )	370.37	in <sup>4</sup>
Controlling Failure Mode	Transverse sidesway buckling below the X-bracing	
Lcr measured from pile cap to NGL (ft)	34.2	ft
Critical Scour (ft)	19.5	ft
Buckling Evaluation	Safe!	

Exit  Continue

**Figure 6.13 Buckling Evaluation Form**

Data that was input previously is echoed in the top half of the form, while the bottom half of the form shows calculated results. The user may note the effective moment of inertia, calculated by the program, that corresponds to the given bent geometry and

amount of scour. The controlling buckling failure mode will be either non-sidesway buckling in the longitudinal direction, transverse sidesway buckling below the bracing, or transverse sidesway buckling from the pile cap to the new ground line for unbraced bents. Finally, the safety check for the user-provided estimated maximum scour value is shown at the bottom of the form. For this example, an effective moment of inertia of  $370 \text{ in}^4$  was calculated by the tool. The failure mode was determined to be sidesway buckling below the horizontal brace in the transverse direction.

The critical unbraced length and corresponding critical scour value are also given so the engineer may assess the bent for future scour susceptibility. The critical buckling length was determined to be 34.2 feet and the critical scour value was 19.5 feet. Note the critical buckling length is measured from the pile cap connection to the new ground line. Because the critical scour value (19.5 feet) is greater than the estimated scour value (15 feet) the bent is safe in buckling. The screening tool calculations for the critical scour values will be discussed in further detail in Chapter 7. In this section, though, the user may note their location on the automated screening tool form.

## **6.5 Pushover Evaluation**

Much like the buckling form, the given input needed to access the database containing the pushover values for various bent configurations is echoed at the top of the form, while the results are shown at the bottom of the form. Based on the span of the bridge, either the small or larger debris raft force is shown. If there is no history of debris raft formation at the bridge site, the minimum raft force of 1.5 kips is used. The pushover form is shown in Figure 6.14.




The following information was previously determined.

Span Length (ft)	36.0	ft
Maximum Bent Applied Load (kips)	160.0	kips
History of Debris Raft?	Yes	

**Pushover Evaluation:**

P-Load Used (kips)	40.0	kips
Design Raft Force	12.93	kips
Pushover Safety	Safe!	
Critical Scour	Greater than 20ft	

Exit  Continue

**Figure 6.14 Bent Pushover Evaluation Form**

As previously discussed, only certain bent geometries were investigated, therefore the user will be advised if the bent is outside the range of the screening tool applicability for pushover evaluation. First, the applied gravity load must be estimated. Because bent pushover is a global phenomenon, it is recommended that the gravity load be equal to the maximum bent load divided by the number of piles. Therefore, all piles are loaded evenly with a portion of the maximum bent load. This is not equal to the maximum single pile load, but a lower load. However, using the maximum pile applied load on every pile would be overly conservative. The calculated load for the bent is then rounded up to the nearest case investigated in the screening tool as 20, 40,

or 60 kips. In a similar fashion, the scour depth is rounded to 5, 10, 15, or 20 feet. The user will be alerted if input is outside the range of investigated cases. The safety assessment, in addition to the critical scour value, is provided by the program in the bottom half of the form.

Note that only scour levels less than or equal to 20 feet were considered in this screening tool. Therefore, all bents pronounced safe by the screening tool may possibly fail in pushover for a scour value greater than 20 feet. Further research would be required to determine the safety of these out-of-typical-range values. This applicability range is represented by the screening tool by designation of a critical scour value of "Greater than 20 ft". For example, in the form above, the critical scour is designated in this manner. Note also that the larger debris raft force, 12.93 kips, was used for the analysis because the bent's span is in the 25-to-36 feet span range corresponding to the larger debris raft.

## 6.6 Beam-Column Evaluation

The final evaluation form for beam-column failure is shown in Figure 6.15.

The following information was previously entered by the user.		
History of Debris Raft?	Yes	
Is bent X-Braced?	X-braced	
Pile Butt Diameter, d (in)	12	in.
Bent Height, H (ft)	16.0	ft
Scour, S (ft)	12.0	ft
Span Length (ft)	36.0	ft
Beam-Column Evaluation:	Safe!	
Critical Scour:	Greater than 20ft	ft

Exit ➔ Continue

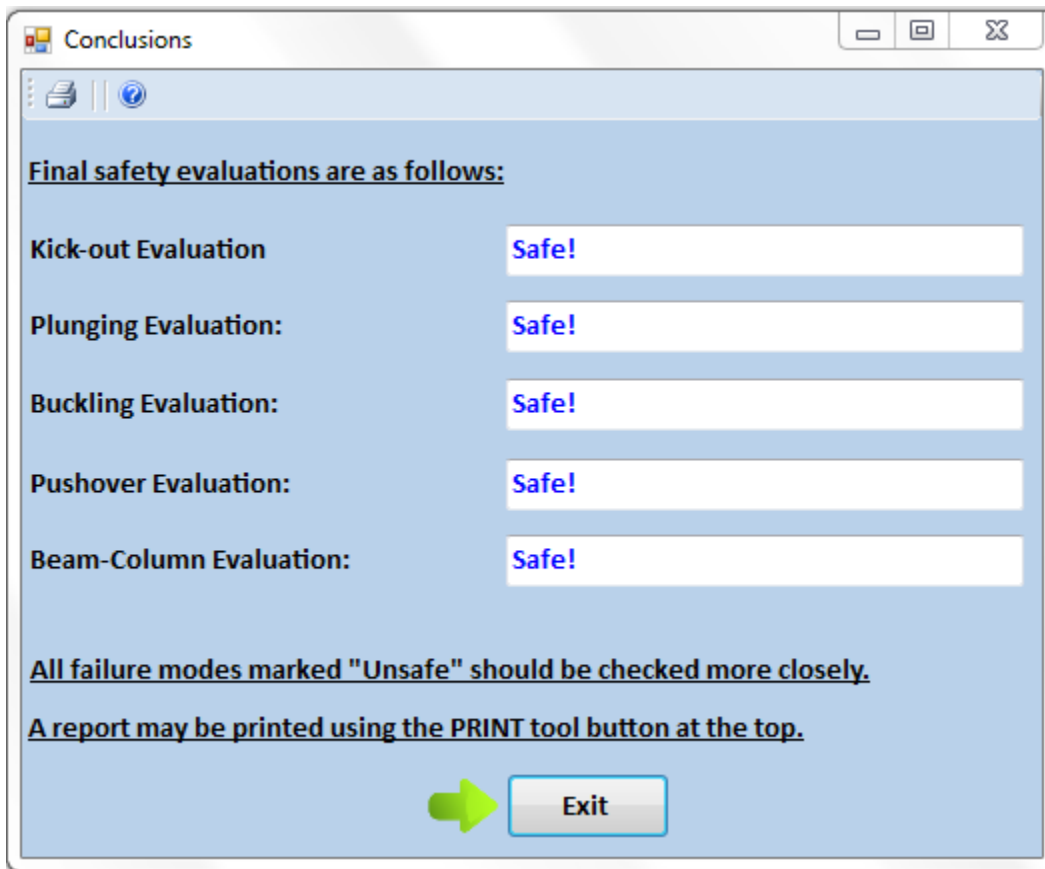
**Figure 6.15 Beam-Column Evaluation Form**

No intermediate calculations are performed by the screening tool program; rather, the bent is determined safe based on the conclusions made by the analysis of a broad range geometries and pile loadings. The safety is determined using Figure 5.7, or Block 5 of the micro-flowchart, discussed in Chapter 5 of this report. The critical scour value for beam-column assessment is also included in the form. Because only broad cases of scour (0, 5, 10, 15, and 20 feet) were investigated, the critical scour is given in terms of these values. Note that a critical scour value of “0” would indicate that the pile is

inherently unstable as a beam-column before any addition of load. For this example, the critical scour is “Greater than 20ft”. Recall that the largest scour value considered in the analysis was 20 feet. Therefore, a bent pronounced “safe” has only been evaluated for a specific scour range. The user, therefore, is alerted that the bent may fail at scour depths greater than 20 feet.

## 6.7 Conclusions and Output Report

The final form of the screening tool, shown in Figure 6.16, is a summary of the safety assessments for each of the five possible failure modes.



The screenshot shows a window titled "Conclusions" with a toolbar at the top containing a printer icon, a vertical bar icon, and a help icon. The main content area has a light blue background and contains the following text:

**Final safety evaluations are as follows:**

<b>Kick-out Evaluation</b>	Safe!
<b>Plunging Evaluation:</b>	Safe!
<b>Buckling Evaluation:</b>	Safe!
<b>Pushover Evaluation:</b>	Safe!
<b>Beam-Column Evaluation:</b>	Safe!

**All failure modes marked "Unsafe" should be checked more closely.**

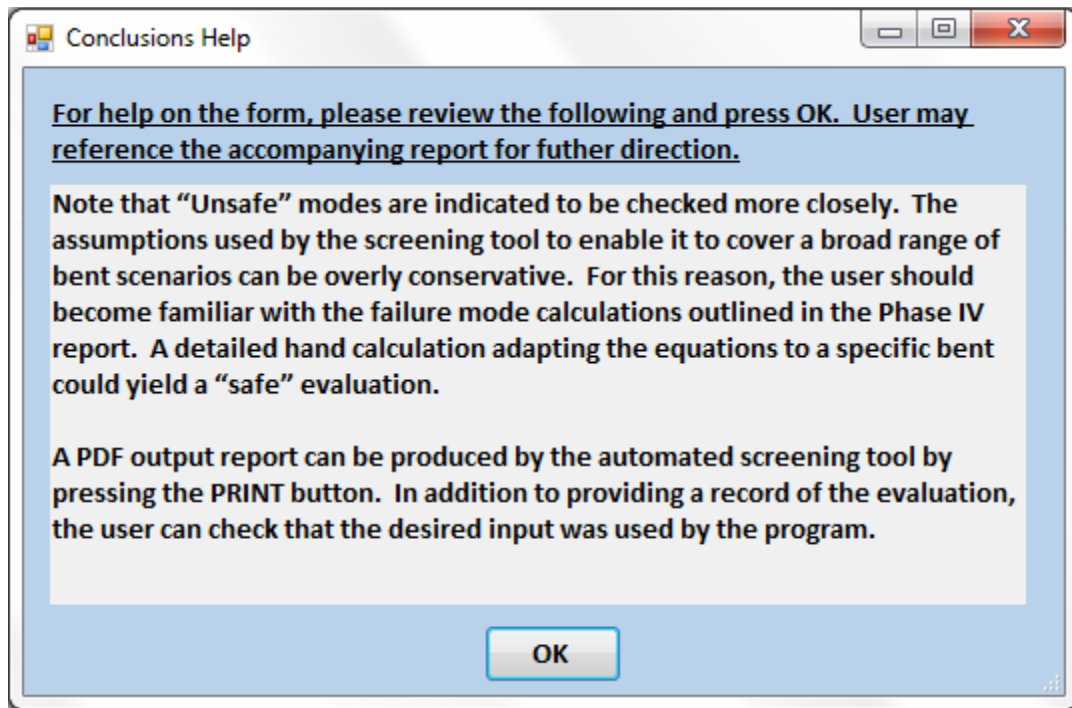
**A report may be printed using the PRINT tool button at the top.**

At the bottom center, there is a green arrow pointing right towards a button labeled "Exit".

**Figure 6.16 Final Conclusions Form**

The example braced bent was safe for all modes, which is identical to the conclusions determined using the manual screening tool in the Milestone Report No.1. All modes

that have been designated as unsafe should be checked more closely. Because this is a simplified screening tool, very conservative assumptions have been made. A more detailed analysis of the failure modes, with more accurate input numbers (i.e. closer to actual conditions), may yield a safe evaluation. Pressing the HELP icon in the toolbar will display the dialog box shown in Figure 6.17.



**Figure 6.17 Conclusions and Printing Help Dialog Box**

Using the print (PRINT) button located in the toolbar at the top of this form will bring up a new dialog box (shown in Figure 6.18) that will allow the user to print an output report of the bent scour analysis.

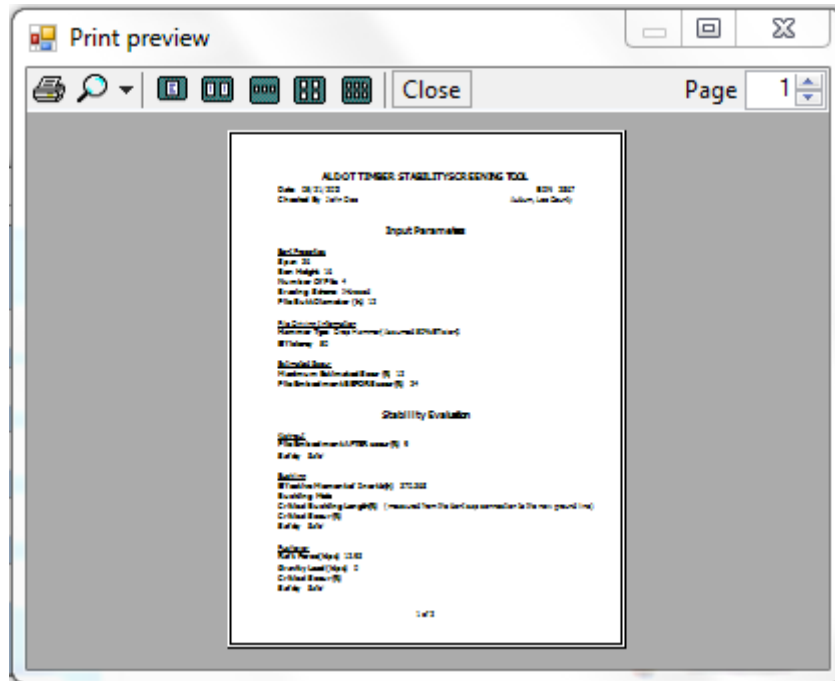
The image shows a software window titled "Print" with a standard Windows-style title bar (minimize, maximize, close buttons). The window contains a form with a light blue background. At the top, a bold instruction reads: "Please fill out the following before printing the report." Below this, there are several input fields:

- "Analysis performed by:" with the text "John Doe" entered.
- "Date:" with the text "5/21/2012" entered.
- "Bridge Identification Number (BIN):" with the text "2867" entered.
- "Bridge Location:" which is split into two sub-fields:
  - "City:" with the text "Auburn" entered.
  - "County:" with the text "Lee" entered.
- "Additional Notes:" followed by a large text area containing the text: "Bent was not located over water. No marine borer or rot issues present."

At the bottom of the form, there are two buttons: "EXIT" on the left and "PRINT" on the right. The "PRINT" button is highlighted with a grey gradient, indicating it is the active or selected option.

**Figure 6.18 Printing Form**

Logistical information such as the engineer performing the analysis, date of analysis, bridge identification number (BIN), and bridge location are inputted by the user. In addition, a textbox is supplied at the bottom of the form for miscellaneous information. This textbox is ideal for noting geometric assumptions made by the user, issues alerted by the screening tool such as marine rot or borers, and any other information deemed necessary for record-keeping purposes. Pressing the print (PRINT) button will display a small preview of the document shown in Figure 6.19.



**Figure 6.19 Print Preview of Printable Output Report**

This window is then maximized to display a full view of the output report. The user may check the input parameters used by the screening tool for correctness. Pressing the printer icon at the top left-hand corner will print the report. Note that the program automatically chooses the default printer on the user's computer. The example output report is shown in Figures 6.20 and 6.21.

## ALDOT TIMBER STABILITY SCREENING TOOL

Date 05/22/2012

BIN 2867

Checked By John Doe

Auburn, Lee County, Alabama

### Input Parameters

#### Bent Properties

Span (ft) 36

Bent Height (ft) 16

Depth of water under bent (ft) 0

Number Of Piles 4

Bracing Scheme X-braced

Pile Butt Diameter (in.) 12

#### Pile Driving Information

Hammer Type Drop Hammer (Assumed 50% Efficient)

Efficiency 50

#### Estimated Scour

Maximum Estimated Scour (ft) 12

Pile Embedment BEFORE scour (ft) 24

#### Applied Loads

Maximum pile applied load (unfactored) (kips) 40

Maximum bent applied load (unfactored) (kips) 160

### Stability Evaluation

#### Kick-out

Pile Embedment AFTER scour of most critical pile (ft) 9

Safety Safe!

#### Buckling

Effective Moment of Inertia (in) 370.37

Buckling Mode Transverse sidesway buckling below the X-bracing

Critical Buckling Length(ft) 34.2 (measured from the bent cap connection to the new ground line)

Critical Scour (ft) 19.5

Safety Safe!

Figure 6.20 Example Output Report (Page 1 of 2)



### ALDOT TIMBER STABILITY SCREENING TOOL

Date 05/22/2012

BIN 2867

Checked By John Doe

Auburn, Lee County, Alabama

#### Pushover

Raft Force (kips) 12.93

Gravity Load (kips) 40

Critical Scour (ft) Greater than 20ft

Safety Safe!

#### Beam-Column

Safety Safe!

Critical Scour (ft) Greater than 20ft

#### Plunging

Pile	1	6	7	8	9
Hammer Rated Energy (lb-ft)	12000	11500	11000	12000	12000
Driving Resistance (bpi)	4	5.5	5	4.3	5
Embedment AFTER Scour (ft)	9	14	14	12	12

#### Friction

Capacity (tons)	21.24	33.28	30.63	27.32	29.32
Critical Scour (ft)	15.72	16.96	16.05	16.13	16.90
Safety	SAFE	SAFE	SAFE	SAFE	SAFE

#### End-Bearing

Capacity (tons)	28.56	38.74	35.65	33.39	35.83
Critical Scour (ft)	22.01	23.74	22.47	22.59	23.67
Safety	SAFE	SAFE	SAFE	SAFE	SAFE

**Additional Notes:** Bent is not located over water.  
No marine borer or rot issues present.

Figure 6.21 Example Output Report (Page 2 of 2)

## CHAPTER 7

### AUTOMATIC SCREENING TOOL POST-ANALYSES

#### 7.1 General

In order to check the accuracy of the automated screening tool, various scenarios involving multiple bent geometries, pile loads, and scour depths were evaluated with the tool. In the course of these evaluations, patterns emerged for different failure modes. These patterns and the reasoning behind them were investigated. The results will be discussed in this chapter.

#### 7.2 Buckling Post-Analyses

To check the accuracy of the buckling evaluation form, patterns of failure modes (either longitudinal non-sidesway or transverse sidesway) were investigated. This investigation was limited to braced bents since all unbraced bents are assumed to fail by transverse sidesway buckling. In addition, a study to verify that the critical scour depths predicted by the tool are accurate and conservative was conducted.

##### 7.2.1 Effects of Pile Embedment Length on Buckling Evaluations of Braced Bents

Table 7.1 summarizes the results produced by the automated screening tool for the buckling evaluation of certain braced bents. The critical buckling length is measured from the pile cap to the new ground line (NGL) for all buckling modes. Recall that even though the buckling length for transverse sidesway buckling only includes the pile portion located below the horizontal brace, the screening tool displays this critical

buckling length plus the pile length above the horizontal brace (i.e. the critical buckling length,  $l_{cr}$ , is always measured from the pile cap down to the new ground line in the screening tool). This length is more easily measured by ALDOT engineers, and was therefore cited to be a preferable output for the automated screening tool. In addition, the buckling lengths, if measured from the same point, are comparable and therefore easier for analysis purposes. The failure mode indicated by the screening tool for all of these bents was transverse sidesway buckling below the horizontal brace. Note that the pile embedment length before scour for these cases is large (20 feet).

**Table 7.1 Critical Transverse Sidesway Buckling Lengths and Scour Depths for Braced Bents, 12 in. Pile Butt Diameter, 20 ft Pile Embedment**

Bent Height, H (ft)	Scour Depth, S (ft)	P-Load (kips)	$l_{CR}$ (ft)	$S_{CR}$ (ft)
8	10	20	42.3	35.5
		30	35.5	28.8
		40	31.5	24.8
		50	28.8	22.0
		60	26.7	20.0
	15	20	39.5	32.8
		30	33.3	26.5
		40	29.5	22.8
		50	27.0	20.3
		60	25.1	18.4
12	10	20	43.0	32.3
		30	36.8	26.1
		40	33.2	22.4
		50	30.7	19.9
		60	28.8	18.1
	15	20	40.3	29.6
		30	34.7	23.9
		40	31.3	20.6
		50	29.0	18.3
		60	27.3	16.6

While Table 7.1 shows results for only some bent geometries, many more cases of bent height, scour, and gravity loads were investigated for the same initial pile embedment length. In the results of the buckling evaluation of these braced bents,

transverse sidesway buckling was overwhelmingly cited by the screening tool as the most critical failure mode. Further investigation was performed to determine why this was the case, and if longitudinal buckling could ever be the critical failure mode.

First, Table 7.1 was extended to include the critical scour values and critical buckling lengths corresponding to longitudinal buckling failure and these are shown in Table 7.2. The screening tool will only display the values for the critical failure mode (transverse sidesway buckling in these cases); therefore the longitudinal buckling critical values were hand-calculated using the process described in Section 4.4 for braced bents.

**Table 7.2 Critical Scour Values for Transverse and Longitudinal Buckling for Braced Bents, 12 in. Pile Butt Diameter, 20 ft Pile Embedment**

Bent Height, H (ft)	Scour Depth, S (ft)	Buckling Coefficient, C	P-Load (kips)	Transverse Buckling		Longitudinal Buckling	
				$l_{CR}$ (ft)	$S_{CR}$ (ft)	$l_{CR}$ (ft)	$S_{CR}$ (ft)
8	10	2.0	20	42.3	<b>35.5</b>	75.2	68.5
			30	35.5	<b>28.8</b>	61.4	54.7
			40	31.5	<b>24.8</b>	53.2	46.5
			50	28.8	<b>22.0</b>	47.6	40.8
			60	26.7	<b>20.0</b>	43.4	36.7
	15	1.50	20	39.5	<b>32.8</b>	60.3	53.6
			30	33.3	<b>26.5</b>	49.3	42.5
			40	29.5	<b>22.8</b>	42.6	35.9
			50	27.0	<b>20.3</b>	38.2	31.4
			60	25.1	<b>18.4</b>	34.8	28.1
12	10	2.0	20	43.0	<b>32.3</b>	70.6	60.0
			30	36.8	<b>26.1</b>	57.8	47.0
			40	33.2	<b>22.4</b>	50.0	39.3
			50	30.7	<b>19.9</b>	44.7	34.0
			60	28.8	<b>18.1</b>	40.9	30.1
	15	1.50	20	40.3	<b>29.6</b>	56.6	45.8
			30	34.7	<b>23.9</b>	46.2	35.4
			40	31.3	<b>20.6</b>	40.0	29.3
			50	29.0	<b>18.3</b>	35.8	25.0
			60	27.3	<b>16.6</b>	32.7	21.9

As can be seen in Table 7.2, the critical scours for transverse buckling, which are shaded, are less than for longitudinal buckling, verifying that the screening tool was accurate in citing transverse buckling as the critical buckling failure mode. Notice that the critical buckling lengths for transverse buckling also are shorter than the longitudinal buckling lengths in every instance. It should be noted also that the buckling coefficient changes from 2.0 to 1.5 with an increase in scour depth from 10 to 15 feet. With the larger scour depth, the fixity condition is no longer valid and a partial fixity becomes more realistic.

To check the accuracy of the screening tool's critical scour calculation, the corresponding critical load,  $P_{cr}$ , was determined using Equation 4-18 for transverse buckling and Equation 4-12 for longitudinal buckling using the critical scour values produced by the screening tool shown in Table 7.2. The results are summarized in Table 7.3. Notice, the given gravity load is equal to the allowable load for transverse buckling at the critical scour depth. This is expected since the critical scour depth should correspond to the point where the allowable load is maximized. At any gravity load less than the allowable load, the bent still has unused capacity. At any gravity load greater than the allowable load, the bent is unstable. The critical scour value corresponds to the point where the bent first becomes unstable at the maximum estimated gravity load. The allowable longitudinal buckling load, on the other hand, is much greater than the gravity load, again verifying that it does not control because the bent still has unused longitudinal buckling capacity. Recall that the buckling evaluation in the screening tool includes a factor of safety of 1.33.

**Table 7.3 Corresponding Allowable Loads based on Critical Scour for Braced Bents, 12 in. Pile Butt Diameter, 20 ft Pile Embedment**

Bent Height, H (ft)	Scour Depth, S (ft)	P-Load (kips)	$S_{CR}$ (ft)	Corresponding Allowable Load, $P_{Allow}$ (kips)	
				Buckling Mode	
				Transverse	Longitudinal
8	10	20	35.5	<b>20.0</b>	60.8
		30	28.8	<b>30.0</b>	86.2
		40	24.8	<b>40.0</b>	110
		50	22.0	<b>50.0</b>	132
		60	20.0	<b>60.0</b>	153
	15	20	32.8	<b>20.0</b>	44.7
		30	26.5	<b>30.0</b>	63.1
		40	22.8	<b>40.0</b>	80.1
		50	20.3	<b>50.0</b>	95.9
		60	18.4	<b>60.0</b>	111
12	10	20	32.3	<b>20.0</b>	49.8
		30	26.1	<b>30.0</b>	68.1
		40	22.4	<b>40.0</b>	83.9
		50	19.9	<b>50.0</b>	98.7
		60	18.1	<b>60.0</b>	112
	15	20	29.6	<b>20.0</b>	36.0
		30	23.9	<b>30.0</b>	49.0
		40	20.6	<b>40.0</b>	60.4
		50	18.3	<b>50.0</b>	70.4
		60	16.6	<b>60.0</b>	79.7

In order to determine the condition where longitudinal buckling will control, the respective equations for transverse and longitudinal buckling loads were compared. Longitudinal buckling should be considered the controlling case if its critical load,  $P_{crL}$ , is less than the critical buckling load for transverse buckling,  $P_{crT}$ . Recalling the equations for the critical load for these two buckling failure modes, longitudinal buckling should be the critical value for a braced bent if the following condition is satisfied:

$$P_{CR_T} = \frac{0.5\pi^2 E I_{eff_T}}{l_{CR_T}^2} \geq \frac{C\pi^2 E I_{eff_L}}{l_{CR_L}^2} = P_{CR_L} \quad (7-1)$$

Recall that the buckling coefficient,  $C$ , for longitudinal buckling is based on the length of embedment as discussed in Section 4.4. Note the different effective moments of inertia for longitudinal buckling and transverse buckling,  $I_{effL}$  and  $I_{effT}$  in Equation 7-1.

Instead of considering the controlling failure mode in terms of critical loads, the controlling failure mode can be considered in terms of critical unbraced buckling lengths. For longitudinal buckling to control, its unbraced length must be longer than the unbraced length for transverse sidesway buckling. To compare the buckling lengths accurately, recall that the effective moment of inertia for transverse sidesway buckling is always smaller than that of longitudinal buckling. The two-thirds of critical buckling length will be at a lower height for buckling below the cross-bracing (i.e. for transverse buckling). To account for this condition, the transverse buckling moment of inertia can be assumed to be a percentage of the longitudinal buckling moment of inertia. To choose a reasonable value, the differences in the effective moments of inertia were investigated. The results can be seen in Table 7.4.

**Table 7.4 Difference in Effective Moment of Inertia Based on Buckling Mode**

Bent Height (ft)	Pile Butt Diameter (in.)	Scour Value (ft)	Effective Moment of Inertia (in <sup>4</sup> )		Percent Difference (%)
			Buckling Mode		
			Transverse Sidesway below Bracing	Longitudinal	
20	12	20	222	308	72%
	14		531	693	77%
	12	15	269	367	73%
	14		620	800	78%
15	12	20	294	367	80%
	14		667	800	83%

While the smallest percent difference is 72%, it would be overly conservative to assume this value as representative of all bents. Therefore, the effective moment of inertia for transverse buckling below the bracing buckling mode was assumed to be approximately 75% of the longitudinal buckling mode effective moment of inertia. Equation 7-1, then, can be rewritten in terms of one effective moment of inertia.

$$P_{CR_T} = \frac{0.5\pi^2 E(0.75I_{eff})}{l_{CR_T}^2} \geq \frac{C\pi^2 EI_{eff}}{l_{CR_L}^2} = P_{CR_L} \quad (7-2)$$

With these geometric assumptions, Equation 7-2 can be rearranged resulting in the following necessary condition for longitudinal buckling to control:

$$l_{CR_T}^2 \leq l_{CR_L}^2 \cdot \frac{0.375}{C} \quad (7-3)$$

Because the equation was written in terms of an identical effective moment of inertia and modulus of elasticity,  $EI_{eff}$  could be eliminated from Equation 7-2. The critical condition can be further simplified to the following by substituting the equations for critical buckling length provided in Section 4.4.

$$\sqrt{l_{CR_T}^2} \leq \sqrt{l_{CR_L}^2} \cdot \sqrt{\frac{0.375}{C}} \quad (7-4)$$

$$S + 1.25 \leq (H + S - 1.25) \cdot \sqrt{\frac{0.375}{C}} \quad (7-5)$$

Finally, rearranging the equation in terms of a critical bent height necessary for longitudinal buckling to control:

$$H \geq \frac{(S+1.25)}{\sqrt{\frac{0.375}{C}}} - (S - 1.25) \quad (7-6)$$

If a bent is taller than the critical bent height found using Equation 7-6, longitudinal buckling should be the critical failure mode. Note that the critical bent height depends



on the estimated scour value,  $S$ , and the embedment length (which dictates the value of the buckling coefficient,  $C$ ).

Table 7.5 was generated using Equation 7-6 for varying scour depths,  $S$ , and buckling coefficients,  $C$ . Note that these results are based on an assumption of identical pile materials and geometries (see Equation 7-2), and that the controlling failure mode is that which corresponds to the lower ultimate critical load,  $P_{CR}$ . For all braced bents in which the bent height is greater than or equal to the value in Table 7.5, longitudinal buckling will be the controlling failure mode.

**Table 7.5 Critical Bent Heights for Longitudinal Buckling Control**

Scour, $S$ (ft)	Critical Bent Height, $H$ (ft)		
	Buckling Coefficient, $C$		
	1.0	1.50	2.0
1.25	4.08	5.00	5.77
2.50	4.87	6.25	7.41
5.00	6.46	8.75	10.7
10.0	9.62	13.8	17.2
15.0	12.8	18.8	23.8
20.0	16.0	23.8	30.3

As can be seen Table 7.5, with increasing scour, the critical bent height also increases. In other words, for larger scour values, bents must be increasingly tall for longitudinal buckling to control. Recalling that the maximum considered scour value and bent height are both 20 feet, in order to achieve a fixity for the longitudinal buckling mode in the most extreme pile scenario, the pile length would be in excess of 48 feet ( $H + S + l_{as} = 20 \text{ ft} + 20 \text{ ft} + 8 \text{ ft} = 48 \text{ ft}$ ). This would be exceptionally long, therefore the values in the  $C = 2.0$  column for Table 7.5 would not be representative of most piles. Rather, critical values in the  $C = 1.50$  column more closely represent typical timber piles and thus are shaded in the table. Recalling that the minimum bent height considered in

the screening tool is 8 feet, for scour values less or equal to 5 feet ( $S = 1.25$  feet,  $S = 2.50$  feet, and  $S = 5.0$  feet), longitudinal buckling will typically control based on this  $C = 1.50$  column because the critical bent height (5.0 feet, 6.25 feet, and 8.75 feet) either will or likely will be exceeded. For the larger scour values ( $S = 15$  feet and  $S = 20$  feet), the critical bent height (18.8 feet and 23.8 feet) is not likely to be exceeded, therefore transverse buckling will typically control. While no complete conclusion could be drawn on the likelihood of buckling mode control for mid-range scour values ( $5 \text{ feet} < S < 15 \text{ feet}$ ), in general the larger scour values tend towards transverse buckling while smaller scour ten towards longitudinal buckling.

From Table 7.5 for critical bent heights, it can also be noted that for increasing buckling coefficients, the critical bent height for longitudinal buckling to control also increases. Therefore, transverse buckling will be the predominant failure mode for bents with large pile embedments. (Longer embedments ensure that a “fixed” condition is still viable even after extreme scour events, i.e. a buckling coefficient of 2.0 is appropriate). For example, for 10 feet of scour, the critical bent height for a buckling coefficient of 1.0 (pinned) is 9.62 feet, while the critical bent height for a buckling coefficient of 2.0 (fixed) is 17.2 feet. Recalling that the screening tool’s applicable bent height range is 8 to 20 feet, most bents will have a height less than the critical height of 17.2 feet, therefore, most bents will be controlled by transverse buckling.

For the example case used in this chapter, bent heights considered were 8 and 12 feet and the embedment before scour for these bents was 20 feet. Recall that the longitudinal buckling coefficients are 2.0 and 1.5 for 10 feet and 15 feet of scour, respectively. From Table 7.5, the critical bent height for longitudinal buckling control is

17.2 feet if the pile is considered fixed for 10 feet of scour. For the example case, piles were considered still “fixed” after 10 feet of scour and therefore both example bents have pile heights less than the critical bent height of Table 7.5. This verifies that transverse buckling should be the controlling failure mode as indicated by the screening tool. Likewise, after 15 feet of scour, the critical bent height is 18.8 feet according to Table 7.5, greater than both example bent heights of 8 and 12 feet. Again, transverse buckling failure should have been the controlling failure mode, verifying the screening tool results.

In order to further investigate the effect of initial embedment on scour susceptibility, the buckling evaluation process was repeated for the same example bent geometries previously discussed, but assuming an initial embedment of only 18 feet instead of 20 feet. This change only affected the buckling coefficient for 15 feet of maximum estimated scour depth. The coefficient shifted to a value of 1.0, a pinned condition, rather than 1.50, a partially fixed condition. The results are shown in Table 7.6. Note that the same moment of inertia is used, therefore transverse buckling lengths and critical scours are identical to those in Table 7.2. The controlling critical scour values are shaded.

**Table 7.6 Critical Scour Values for Transverse and Longitudinal Buckling for Braced Bents, 12 in. Pile Butt Diameter, 18 ft Pile Embedment**

Bent Height, H (ft)	Scour Depth, S (ft)	Buckling Coefficient, C	P-Load (kips)	Transverse Buckling		Longitudinal Buckling	
				$l_{CR}$ (ft)	$S_{CR}$ (ft)	$l_{CR}$ (ft)	$S_{CR}$ (ft)
8	10	2.0	20	42.3	<b>35.5</b>	75.2	68.5
			30	35.5	<b>28.8</b>	61.4	54.7
			40	31.5	<b>24.8</b>	53.2	46.5
			50	28.8	<b>22.0</b>	47.6	40.8
			60	26.7	<b>20.0</b>	43.4	36.7
	15	1.0	20	39.5	<b>32.8</b>	49.3	42.5
			30	33.3	<b>26.5</b>	40.2	33.5
			40	29.5	<b>22.8</b>	34.8	28.1
			50	27.0	<b>20.3</b>	31.2	24.4
			60	25.1	<b>18.4</b>	28.4	21.7
12	10	2.0	20	43.0	<b>32.3</b>	70.6	60.0
			30	36.8	<b>26.1</b>	57.8	47.0
			40	33.2	<b>22.4</b>	50.0	39.3
			50	30.7	<b>19.9</b>	44.7	34.0
			60	28.8	<b>18.1</b>	40.9	30.1
	15	1.0	20	40.3	<b>29.6</b>	46.2	35.4
			30	34.7	<b>23.9</b>	37.7	27.0
			40	31.3	<b>20.6</b>	32.7	21.9
			50	29.0	<b>18.3</b>	29.2	18.5
			60	27.3	16.6	26.7	<b>15.9</b>

Notice that longitudinal buckling failure now controls for the highest gravity load and the greatest scour depth because of the reduction in the buckling coefficient from 1.50 (partially fixed) to 1.0 (pinned). Also notice that in cases where transverse buckling still controls, and where  $C = 1.0$ , the critical scours for longitudinal buckling are less than those in Table 7.2 where a 20 feet embedment was assumed, which is reasonable. Additionally, notice that the longitudinal critical scour depth converges towards the transverse buckling critical scour depth until it overtakes the transverse buckling critical scour depth to become the more critical scour depth towards the bottom of the table.

As was done with the previous example, the corresponding allowable loads for transverse and longitudinal buckling were then calculated using the critical scour depths. The results can be seen in Table 7.7. All the critical scours (which are shaded in the table) correspond to the applied gravity load, indicating that the calculations are correct.

**Table 7.7 Corresponding Allowable Loads based on Critical Scour for Braced Bent, 12 in. Pile Butt Diameter, 18 ft Pile Embedment**

Bent Height, H (ft)	Scour Depth, S (ft)	P-Load (kips)	$S_{CR}$ (ft)	Corresponding Allowable Load, $P_{allow}$ (kips)	
				Buckling Mode	
				Transverse	Longitudinal
8	10	20	35.5	<b>20.0</b>	60.8
		30	28.8	<b>30.0</b>	86.2
		40	24.8	<b>40.0</b>	109.6
		50	22.0	<b>50.0</b>	132.4
		60	20.0	<b>60.0</b>	152.5
	15	20	32.8	<b>20.0</b>	29.8
		30	26.5	<b>30.0</b>	42.1
		40	22.8	<b>40.0</b>	53.4
		50	20.3	<b>50.0</b>	63.9
		60	18.4	<b>60.0</b>	73.7
12	10	20	32.3	<b>20.0</b>	49.8
		30	26.1	<b>30.0</b>	68.1
		40	22.4	<b>40.0</b>	83.9
		50	19.9	<b>50.0</b>	98.7
		60	18.1	<b>60.0</b>	111.6
	15	20	29.6	<b>20.0</b>	24.0
		30	23.9	<b>30.0</b>	32.7
		40	20.6	<b>40.0</b>	40.3
		50	18.3	<b>50.0</b>	67.6
		60	15.9	72.6	<b>60.0</b>

Note that the longitudinal allowable loads for 15 feet of scour, where the pinned condition is now used, are quickly approaching the gravity load. Notice also that for the

12 foot high bent at higher gravity loads, the longitudinal buckling failure again overtakes the transverse buckling load to become the controlling failure mode.

### **7.2.2 Effect of the Chosen Effective Moment of Inertia on Critical Scour Depth**

The critical unbraced length and critical scour results produced by the screening tool for various braced and unbraced geometries can be seen in Table 7.8. Note carefully the critical scour values and safety evaluations. Within a given estimated scour, the critical scour values decrease with increasing gravity load. This is logical, since critical load and buckling length are inversely proportional according to the generic Euler buckling equation (see Equation 4-10). In other words, as unbraced length available for buckling is increased, the buckling load-carrying capacity will be decreased. Therefore, to carry a higher gravity load, the unbraced length must be decreased and, by extension, the scour value must be decreased.

**Table 7.8 Critical Scour Depths for Buckling for Braced and Unbraced Bents (16 ft Bent Height, 14 in. Pile Butt Diameter, 20 ft Pile Embedment)**

Bracing Scheme	Bent Height, H (ft)	Scour Depth, S (ft)	P-Load (kips)	$l_{CR}$ (ft)	$S_{CR}$ (ft)	Safety
Unbraced	16	5	20	30.0	15.3	Safe
			30	24.5	9.8	Safe
			40	21.2	6.5	Safe
			50	19.0	4.3	Unsafe
			60	17.3	2.6	Unsafe
		10	20	28.1	13.4	Safe
			30	23.0	8.2	Unsafe
			40	19.9	5.2	Unsafe
			50	17.8	3.0	Unsafe
			60	16.2	1.5	Unsafe
Braced	16	5	20	61.1	46.4	Safe
			30	52.4	37.6	Safe
			40	47.2	32.4	Safe
			50	43.6	28.9	Safe
			60	41.0	26.2	Safe
		10	20	58.0	43.2	Safe
			30	49.8	35.1	Safe
			40	44.9	30.2	Safe
			50	41.6	26.9	Safe
			60	39.2	24.4	Safe

From Table 7.8 it can also be seen that the critical scour value decreases with an increase in estimated scour. For example, for an unbraced 16 foot tall bent carrying a gravity load of 50 kips, the critical scours are 4.3 feet and 3.0 feet for initial estimated scour values of 5 and 10 feet, respectively. However, the critical scour depth should be identical for the same bent height and gravity load, regardless of maximum estimated scour depth. Theoretically, there should be a specific critical scour value for a given bent geometry, indicating the failure case. Further investigation was warranted to determine the reason for the discrepancy.

In order to determine the cause of this inconsistency, the effective moment of inertia was examined for each case. The values can be seen in Table 7.9.

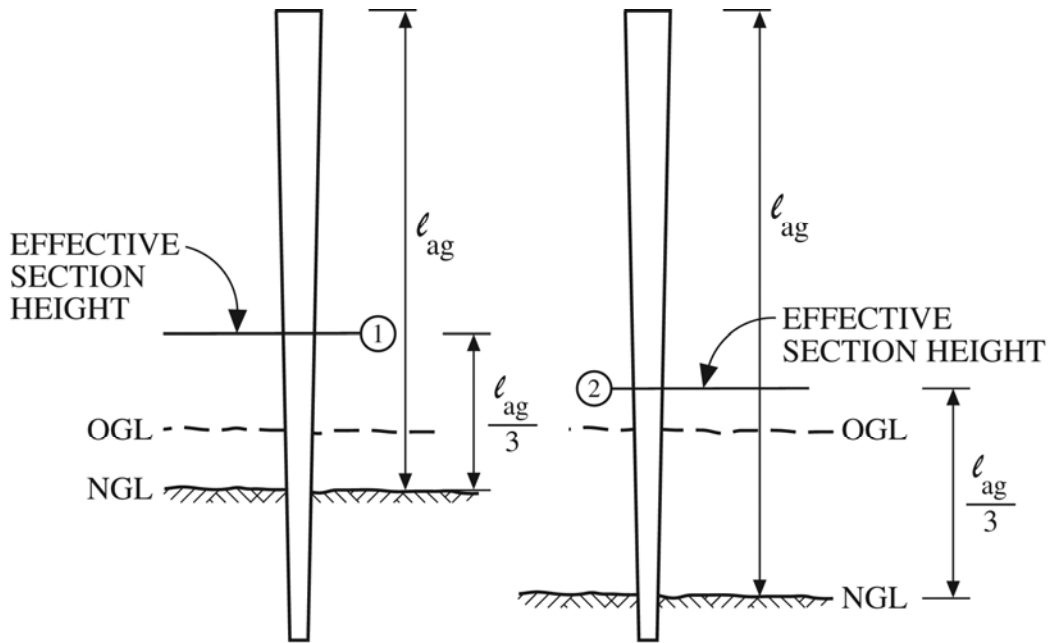
**Table 7.9 Effective Moment of Inertia for Varying Scour Depths**

Bent Height, H (ft)	Bracing Scheme	Scour Depth, S (ft)	$I_{Eff}$ (in <sup>4</sup> )
16	Unbraced	5	1168
		10	1025
	Braced	5	978
		10	853

Because the buckling evaluation assuming 10 feet of estimated scour has a smaller effective moment of inertia than that for 5 feet of scour, its critical scour value is decreased. Recall that moment of inertia is indicative of load-carrying capacity, therefore the critical buckling length is necessarily decreased with an increase in scour, accounting for the loss in load-carrying capacity. The culprit for the inconsistent critical scour values therefore is timber pile taper, which causes the varying moment of inertia.

Recall that an effective section must be chosen to account for pile taper in order to perform the buckling analyses. The effective pile section, according to Section 3.5, is located at one-third of the pile height above ground after scour. Because the selection of the effective section depends on the post-scour geometry, the estimated scour specified by the user of the automated screening tool will determine the effective moment of inertia selected. This effect is illustrated in Figure 7.1. The larger estimated scour values correspond to a larger exposed length of pile after scour. This longer section will exhibit a smaller effective diameter because of the decreasing taper. Therefore, when a larger maximum scour is assumed, a smaller effective moment of inertia will be utilized in the screening tool.





**Figure 7.1 Estimated Scour Effect on Effective Section Selection**

It should be stressed that this effect does not affect the screening tool’s safety evaluation of the bent. The tool does accurately calculate the buckling capacity for the user-provided geometry and scour conditions. It should be noted that this “safety” assignment applies to the present, or estimated, scour condition. However, the evaluation of future scour events may be unconservative. A small estimated scour value yields a large critical scour, leading the user to believe, for a particular case, that the bent can withstand additional scour (up to the critical scour).

To further illustrate this effect on critical scour projections, the critical buckling lengths and scours for a 20 foot braced bent were estimated, focusing on the cases where 60 kips is the maximum applied load as shown in Table 7.10. For an initial maximum estimated scour of 5 feet, the critical scour is calculated as 18.2 feet using an effective moment of inertia of 491 in<sup>4</sup>. However, when an initial maximum estimated

scour of 15 feet is assumed, the critical scour is calculated as 9.8 feet, with an effective moment of inertia of 352 in<sup>4</sup>. All critical scour depths reflect sidesway buckling in the transverse direction below the bracing as the controlling failure mode, unless otherwise noted. For the non-sidesway cases, a different effective moment of inertia is used to represent the different buckling length associated with the buckling mode as discussed in Section 4.4.2.

**Table 7.10 Critical Scour Depths for Buckling for Braced Bent  
(20 ft Bent Height, 12 in Pile Butt Diameter, 20 ft Pile Embedment)**

Bent Height, H (ft)	Scour Depth, S (ft)	P-Load (kips)	$I_{Eff}$ (in <sup>4</sup> )	$l_{CR}$ (ft)	$S_{CR}$ (ft)	Safety
20	5	20	383	47.3	28.6	Safe
		30		41.8	23.1	Safe
		40		38.6	19.8	Safe
		50		36.4	17.6	Safe
		60		34.7	16.0	Safe
	10	20	322	44.8	26.1	Safe
		30		39.8	21.1	Safe
		40		36.8	18.1	Safe
		50		34.8	16.0	Safe
		60		33.3	14.5	Safe
	15	20	269	42.5	23.7	Safe
		30		37.9	19.1	Safe
		40		35.1	16.4	Safe
		50	367*	32.0	13.2	Unsafe
		60		29.2	10.4	Unsafe

\*Non-sidesway buckling controlled

If the user initially assumed 5 feet of scour and the screening tool then produced a critical scour depth of 16.0 feet, the user would assume that the bent would continue to be safe until a total 16 feet of scour has been reached. In other words, the bent could withstand about 11 feet of future scour. However, if the user initially assumed 15 feet of initial scour, he or she would determine from the automated screening tool that the bent

is safe only up to a total 10.4 feet of scour and has failed. In addition, the buckling mode changed from sidesway buckling in the transverse direction below the bracing to non-sidesway buckling in the longitudinal direction when changing the scour estimation from 5 feet to 15 feet. The change in controlling failure mode results in a change in the critical scour depth projection. Also, while the effective moment of inertia for non-sidesway buckling ( $367 \text{ in}^4$ ) is greater than the effective moment of inertia for sidesway buckling ( $269 \text{ in}^4$ ) for the 15 feet-of-scour cases, the effective moment of inertia is still less than that assumed for 5 feet of scour ( $383 \text{ in}^4$ ), causing the critical scour depth to additionally decrease.

Again, this effect does not imply that the buckling safety evaluations of the screening tool are incorrect. Looking back at the previous example, the screening tool produced a critical value of 16.0 feet of scour when given an initial estimate of 5 feet of scour. However, if the tool is given an initial estimate of 15 feet of scour (less than 16.0 feet) the bent is pronounced correctly “unsafe”. Therefore, it should be noted that the safety evaluation, designated as “safe” or “unsafe”, corresponds to the estimated scour value inputted by the user. When considering future scour events, to determine the most conservative critical scour depth, the user should employ an iterative method. After an initial critical scour is determined based on the first assumed maximum scour depth, the program should be run again using that critical scour depth as the new maximum estimated scour depth. This method will converge on a more reliable critical scour depth estimate. An example is shown in Table 7.11.

**Table 7.11 Iteration Example for Most Conservative Critical Scour Depth  
(14 ft Bent Height, 12 in. Pile Butt Diameter, 30 ft Pile Embedment,  
50 kip P-Load, Braced Bent)**

Trial	Scour Depth, $S$ (ft)	$I_{Eff}$ (in <sup>4</sup> )	$S_{CR}$ (ft)	Safety
1	10.0	438.2	18.9	Safe
2	18.9	323.2	16.1	Unsafe

Using the first critical scour depth projection (18.9 feet) as the new estimated scour depth for the second trial yielded a more conservative critical scour depth projection of 16.1 feet. Using 18.9 feet as the new applied estimated scour value decreased the effective section height, therefore decreasing the effective moment of inertia. The smaller effective moment of inertia resulted in a loss of buckling capacity. Note, even with this new, more conservative estimate, the first trial scour value of 10 feet would still be considered “safe”. Therefore, the first trial did not result in a safety evaluation error.

### 7.3 Plunging Post-Analyses

Because plunging is a function of soil interaction with a pile, plunging capacity, when determined by the Modified Gates Equation, is not affected by the bent geometry or pile diameter. Rather, it is determined solely by the pile driving practices and the pile embedment length. As discussed in Section 4.3, the pile embedment represents the length along which the soil can interact with the pile, therefore any loss of embedment corresponds to a loss in plunging capacity. The larger an estimated scour value, then, the greater the loss in plunging capacity. An example driving log with a 13,000 lb-ft drop hammer and an estimated 4 bpi final driving resistance was evaluated using the

automated screening tool, and the results are summarized in Table 7.12. Failure is assumed to occur when the critical scour depth for plunging is less than the estimated scour depth. The unsafe cases are shaded. For this example case, an initial pile embedment of 20 feet was achieved after pile driving. Notice, the capacities for both friction and end-bearing piles decrease with increasing scour depths as expected. Also, note that the friction pile capacities are all smaller, which is expected since the friction capacity is more sensitive to soil loss. Therefore, some cases that are safe as end-bearing piles are not safe as friction piles.

**Table 7.12 Pile Plunging Capacities and Critical Scours for Plunging Failure (4 bpi Final Driving Resistance, 13000 lb-ft Drop Hammer, 20 ft Pile Embedment)**

Estimated Scour Depth (ft)	P-Load (kips)	Friction Pile		End-Bearing Pile	
		$P_{Friction}$ (tons)	$S_{CR}$ (ft)	$P_{End-Bear}$ (tons)	$S_{CR}$ (ft)
5	20	39.4	18.3	42.5	26.7
	30		16.1		22.5
	40		13.8		19.3
	50		11.5		16.1
	60		9.3		13.0
10	20	28.4	18.3	34.7	26.7
	30		16.1		22.5
	40		13.8		19.3
	50		11.5		16.1
	60		<b>9.3</b>		13.0
15	20	17.3	18.3	26.8	26.7
	30		16.1		22.5
	40		<b>13.8</b>		19.3
	50		<b>11.5</b>		16.1
	60		<b>9.3</b>		<b>13.0</b>

While the plunging capacities in Table 7.12 change with the estimated scour depth, the critical scour values do not. They are all the same for each estimated scour level. The critical scours represent the total scour depths at which the pile will plunge,

therefore are independent of the estimated maximum amount of scour. This trend is unlike that observed for the buckling critical scour depths, which were determined to be dependent upon estimated scour values due to buckling's dependence on the effective pile diameter. Plunging, however, is not a function of the pile diameter or, by extension, the pile moment of inertia. There are no issues concerning effective section selection. The pile, after driving, has a nominal maximum allowable load, derived by the Gates Formula. The plunging capacities,  $P_{Friction}$  and  $P_{End-Bear}$ , represent the new in-situ allowable capacities of a pile after a scour event, be it safe or unsafe. The larger the design load a pile must carry, the more of the initial nominal capacity is needed to resist plunging, and therefore, the less loss of embedment the pile can withstand before failure. This loss of embedment is represented by the critical scour value,  $S_{cr}$ . The critical scour depth value, then, decreases with an increase in the gravity load.

As previously discussed, the degree to which the soil interacts with the pile and therefore provides plunging resistance is determined by the driving practices. The higher the resistance at the end of driving, the larger the amount of soil resistance mobilized. The same effect can be assumed for higher hammer energy. The larger the hammer energy during driving, the larger the amount of soil resistance that is mobilized. The example cases of Table 7.12 were repeated using a 5 bpi driving resistance, rather than 4 bpi. The results can be seen in Table 7.13. The friction and end-bearing plunging capacities are increased over those in Table 7.12, and, in turn, the critical scour depths are increased. This is expected since more capacity is available, so more embedment can be lost due to scour. The unsafe cases are shaded in Table 7.13 for easier identification.

**Table 7.13 Pile Plunging Capacities and Critical Scours for Plunging Failure (5 bpi Final Driving Resistance, 13000 lb-ft Drop Hammer, 20 ft Pile Embedment)**

Estimated Scour Depth (ft)	P-Load (kips)	Friction Pile		End-Bearing Pile	
		$P_{Friction}$ (tons)	$S_{CR}$ (ft)	$P_{End-Bear}$ (tons)	$S_{CR}$ (ft)
5	20	43.7	18.8	47.2	26.3
	30		16.7		23.4
	40		14.7		20.6
	50		12.6		17.7
	60		10.6		14.8
10	20	31.4	18.8	38.4	26.3
	30		16.7		23.4
	40		14.7		20.6
	50		12.6		17.7
	60		<b>10.6</b>		14.8
15	20	19.2	18.8	26.7	26.3
	30		16.7		23.4
	40		<b>14.7</b>		20.6
	50		<b>12.6</b>		17.7
	60		<b>10.6</b>		<b>14.8</b>

When comparing to the values in Table 7.12, the 1 bpi increase in final driving resistance results in one case ( $S = 10$  feet,  $P = 60$  kips in friction) changing from an unsafe condition to a safe condition in plunging. This case is shown in bold, but now un-shaded.

Plunging capacity is also affected by the estimated pile embedment length provided by the user. Initial embedment length is indicative of the amount of soil mobilized during driving. The example cases in Table 7.13 were repeated using the same scour depths and driving log, but with an initial pile embedment of 15 feet instead of 20 feet. The results can be seen Table 7.14. As before, the unsafe cases are shaded. Only scour depths of 5 and 10 feet were evaluated, since the 15 feet case would obviously yield zero plunging capacities for a 15 feet embedment length (i.e. the

embedment would become zero after scour, and thereby the plunging capacity would be negligible).

**Table 7.14 Pile Plunging Capacities and Critical Scours for Plunging Failure (5 bpi Final Driving Resistance, 13000 lb-ft Drop Hammer, 15 ft Pile Embedment)**

Estimated Scour Depth (ft)	P-Load (kips)	Friction Pile		End-Bearing Pile	
		$P_{Friction}$ (tons)	$S_{CR}$ (ft)	$P_{End-Bear}$ (tons)	$S_{CR}$ (ft)
5	20	39.6	14.1	44.2	19.7
	30		12.5		17.6
	40		11.0		15.4
	50		9.5		13.3
	60		7.9		11.1
10	20	23.3	14.1	32.6	19.7
	30		12.5		17.6
	40		11.0		15.4
	50		9.5		13.3
	60		7.9		11.1

The capacities and critical scour values were reduced with the reduced pile embedments. As a result, two cases, designated by shading, that were previously determined to be safe (S = 10 feet, P = 50 kips in friction; S = 10 feet, P = 60 kips in friction) become unsafe. In general, when the length of pile embedded is shortened, any increase in scour becomes a larger percent loss of embedment. The larger percent loss of embedment results in a greater percentage loss of plunging capacity. Therefore, the capacities and critical scour values are reduced.

Finally, the effect of a change in hammer type on plunging capacity was investigated. The cases used for Table 7.14 were repeated using a diesel hammer instead of a drop hammer. Diesel hammers are assumed to have an 80% efficiency rate compared to the 50% efficiency rate of a drop hammer. The same hammer energy (13,000 lb-ft) and the same final driving resistance (5 bpi) at the end of driving was



assumed. Fifteen feet of initial pile embedment before scour was also used. The results can be seen in Table 7.15.

**Table 7.15 Pile Plunging Capacities and Critical Scours for Plunging Failure (5 bpi Final Driving Resistance, 13000 lb-ft Diesel Hammer, 15 ft Pile Embedment)**

Estimated Scour Depth (ft)	P-Load (kips)	Friction Pile		End-Bearing Pile	
		$P_{Friction}$ (tons)	$S_{CR}$ (ft)	$P_{End-Bear}$ (tons)	$S_{CR}$ (ft)
5	20	57.6	15.0	64.4	21.1
	30		14.0		19.6
	40		12.9		18.1
	50		11.9		16.6
	60		15.1		10.8
10	20	33.9	15.0	47.4	21.1
	30		14.0		19.6
	40		12.9		18.1
	50		<b>11.9</b>		16.6
	60		<b>15.1</b>		10.8

Because the diesel hammer is more efficient, more soil resistance is mobilized than with the drop hammer, and therefore the plunging capacities are increased. This increase results in all previously unsafe cases becoming safe. These cases are for  $S = 10$  feet and  $P = 50$  kips in friction and  $S = 10$  feet and  $P = 60$  kips in friction (the cases are indicated in bold, but un-shaded since they are now safe). The percent increases in capacity due to the change in hammer type are summarized below in Table 7.16.

**Table 7.16 Percent Increase in Plunging Capacity Based on Hammer Efficiency**

Scour (ft)	$P_{Friction}$ (tons)		Percent Increase	$P_{End-Bear}$ (tons)		Percent Increase
	Drop Hammer	Diesel Hammer		Drop Hammer	Diesel Hammer	
5	39.6	57.6	45%	44.2	64.4	45%
10	23.3	33.9	45%	32.6	47.4	45%

Note that while the effective hammer energy was increased by 60%, the capacities were only increased by 45%. Recall that a loss of pile embedment is considered proportional to a loss in plunging capacity. Hammer energy, however, does not exhibit such a dramatic effect. By inspection of the Modified Gates formula (Equation 4-1), hammer energy,  $E$ , is raised to the half power, therefore not directly proportional to plunging capacity. Therefore, plunging capacity is more sensitive to changes in initial pile embedment length than hammer efficiency.

#### **7.4 Bent Pushover Post-Analyses**

Only one case out of the 630 bent pushover scenarios considered was determined unsafe. In addition, this case is only unsafe for the larger raft size corresponding to a bridge span length greater than 25 feet. According to the ALDOT-provided survey of timber bridges, most bridge spans fall in the 15-to-26 foot range and will be considered safe from bent pushover. This overwhelming safe assessment of timber bridges must be established as realistic.

Table 7.17 summarizes bent pushover forces for steel bents obtained from a previous phase report (Donnee et al. 2008) compared to example timber bent pushover forces. The timber bent pushover values shown correspond to an unbraced 12-inch butt diameter, 4-pile bent with an applied concentrated pile load of 60 kips. The steel pushover values correspond to an unbraced  $HP_{12 \times 42}$  4-pile bent also with an applied concentrated pile load of 60 kips. Note that the timber bent is 12 feet tall, while the steel bent is 13 feet tall. Because the bents utilize different geometries, steel and timber bents are not precisely analogous. These bents were chosen as the most

comparable. Notice that the bent pushover forces for the timber bents are significantly larger than those for steel bents.

**Table 7.17 Pushover Forces,  $F_t$ , for 4-Pile Unbraced Steel and Timber Bents (P-load = 60 kips)**

Scour Depth (ft)	$F_t$ (kips)	
	Steel Pile	Timber Pile
0	47.3	230
5	42.4	148
10	41.0	95.9
15	36.7	60.0
20	29.2	43.8

Because the lateral force required to cause pushover failure is much larger for the timber bent, in general, timber bents could be considered to be laterally stronger than the steel bents. It was concluded that the lateral strength of the timber bents is derived from the larger pile embedments that are necessary for the driving of timber piles. The partial fixity at the ground line seems to provide adequate bent pushover support.

According to the previous report regarding the steel piles, unsafe results were often indicated for the pushover failure mode in steel bents, and therefore warranted concern. Upon further investigation of that report, it was noticed that 60 kips was the smallest gravity load considered for bent pushover for steel bents. In the timber screening tool, however, 60 kips is the maximum considered gravity load. Table 7.18 shows the pushover forces for the same 4-pile steel bent used in the table above. The bent pushover forces for three higher gravity loads are included, in addition to the high levels of scour that were considered in the steel screening tool. The unsafe cases are shaded. Note that the design raft force in the steel screening tool is 12.15 kips.

**Table 7.18 Bent Pushover Forces (kips) for Unbraced 4-pile  $HP_{12 \times 42}$  Steel Bent**

Scour Depth (ft)	Applied Bent Gravity Load (kips)			
	60	100	140	160
0	47.3	41.7	40.5	38.1
5	42.4	36.1	32.4	29.6
10	41.0	35.0	29.6	26.3
15	36.7	29.0	23.1	19.5
20	29.2	22.7	16.0	12.8
25	23.5	16.8	10.5	7.80

As can be seen in Table 7.18, the steel bents do not become unsafe until a relatively higher gravity load is applied ( $P = 140$  or  $160$  kips) and the larger scour level ( $S = 25$  feet) is considered. It can be concluded that the “safety” of timber bents in bent pushover does not speak to the capacity of the bents themselves, which are not especially high, but of the magnitude of the applied bent gravity load. Because timber bridges are typically seen on low-volume roads, applied gravity loads upwards of 100 kips will not be seen on typical timber bents. Timber bents also are not subjected to as high levels of scour as the steel bents, therefore less instability is introduced from the lengthening of exposed pile sections due to embedment loss.

In addition, it should be noted that in the pushover analysis for steel pile bents (specifically steel H-piles), the bent is loaded in its weak axis. Timber piles, on the other hand, are never loaded on a weak axis because one is not present. Due to their circular cross-section, pile orientation has no effect on structural behavior.

## 7.5 Beam-Column Post-Analyses

The most striking observation from the beam-column analyses is the importance of bracing timber bents. The stiffness provided by the cross-bracing enabled all investigated braced bents to be determined safe. Also, the beneficial effect of a larger

pile butt diameter may be observed. As can be seen from the results summarized in Table 7.19, the 14-inch pile can carry larger loads and withstand larger scour values than the 12-inch pile. For the shorter bent (less than 8 feet), the allowable load for the 14-inch pile is more than double that of the 12-inch pile. For the taller bents (between 8 and 12 feet), the 14-inch pile can withstand twice the amount of scour in addition to a larger gravity load.

**Table 7.19 Allowable Scour Depths and Allowable Loads for Beam-Column Evaluation for Braced Timber Bents and Large Debris Rafts**

Bent Height 8 to 12 feet		
Pile Butt Diameter (in.)	Allowable Scour (ft)	Allowable Load (kips)
12	5	32
14	10	44
Bent Height less than 8 feet		
Pile Butt Diameter (in.)	Allowable Scour (ft)	Allowable Load (kips)
12	10	26
14	10	60

## **CHAPTER 8**

### **CONCLUSIONS**

Based on the review of the results of the automated screening tool, the following practices are recommended for proper use of the automated screening tool:

- (1) Insure that the timber bent under investigation falls in the applicable range of the screening tool (see Figure 3.3).
- (2) Review the printable output report to insure that the user-desired input variables were used by the automated screening tool.
- (3) Take note of the assumed geometry of the screening tool (see Figure 3.3), especially the location of the horizontal brace 1.25 feet above the original ground line (OGL).
- (4) In order to safely evaluate a bent for future scour in regards to buckling failure, the critical scour produced by the screening tool with an initial scour estimate should be re-evaluated using this critical scour as the new initial estimate. This iteration will insure that the most conservative critical scour is determined.
- (5) In regards to piles with severe section loss due to marine borer or rot issues, note that the automatic screening tool assumes the original pile

diameter. “Safe” evaluations, therefore, are contingent on the pile being built up to that original diameter.

Based on the limitations of the automated screening described above, it is recommended that the following items be addressed in a future research effort:

- (1) Additional bent pushover analyses could be performed for greater lateral forces, induced by larger debris rafts or overloads, to verify the overwhelming bent pushover safety of timber bents.
- (2) A second level of code could be added to the existing automated screening tool buckling evaluation to determine a new moment of inertia based on the critical scour value, which could then be used to recalculate buckling capacities. In other words, the program could iterate internally, rather than having that accomplished by the user.
- (3) Section loss could be accounted for in a newer revision of the screening tool. This would be most difficult for the beam-column and bent pushover evaluations, where multiple geometries are considered separately. However, it could be accomplished by accounting for certain percent section losses. Buckling, on the other hand, would be easily reflected by a blanket reduction in the effective moment of inertia. No change would be required for the buckling equations. Plunging and kick-out are independent of section loss, so they would not need to be included in this modification

- (4) Two-story bracing could also be considered in a newer revision of the screening tool if needed. The same difficulties that apply to including section loss apply to two-story bracing. Namely, the multitude of geometric cases considered separately for beam-column and bent pushover to account for two-story conditions would make the process quite lengthy.
- (5) Further finite element analyses could be performed comparing a tapered pile and its analogous constant effective section pile. In order to validate the effective section approach used in the screening tool.



## REFERENCES

- AASHTO. *LRFD Bridge Design Specifications (4th Ed.)*. 2007. American Association of State Highway and Transportation Officials. Washington, D.C.
- Bennett, Caroline R., Cheng Lin, Ryan Parsons, and Jie Han. 2009. Evaluation of behavior of a laterally loaded bridge pile group under scour conditions, Structures 2009: Don't Mess with Structural Engineers. American Society of Civil Engineers.
- Bowles, J.E. 1968. *Foundation Analysis and Design*. New York: McGraw-Hill Book Company.
- Chellis, R. D. 1961. *Pile Foundations (2nd Ed.)*. New York: McGraw-Hill Book Company.
- Daniels, Joslyn, Doug Hughes, George E. Ramey, and Mary L. Hughes. May 2007. Effects of bridge pile bent geometry and levels of scour and P loads on bent pushover loads in extreme flood/scour events. Practice periodical on structure design and construction. American Society of Civil Engineers.
- Donnee, N., M.L. Hughes, G.E. Ramey, N. Walker, and D. A. Brown. July 2008. Stability of Highway Bridges Subject to Scour – Phase III – Part II, Alabama Department of Transportation Project No. 930-674. Auburn University, Alabama: Highway Research Center.

- Federal Highway Administration. 2004. Bridges, Structures, and Hydraulics. *National Bridge Inspection Standards*. Washington: Government Printing Office.
- Halvorson, Michael. 2006. *Microsoft Visual Basic 2005: Step by Step*. Redmond, Virginia: Microsoft Press.
- Hughes, Doug, George E. Ramey, and Mary L. Hughes. May 2007. Effects of extreme scour and soil subgrade modulus on bridge pile bent buckling. Practice periodical on structural design and construction. American Society of Civil Engineers.
- Hunt, Beatrice E. 2005. Scour monitoring programs for bridge health. *Transportation Research Record: Journal of the Transportation Research Board CD 11-S: 531-536*. Washington: Transportation Research Board of the National Academies.
- Lin, Cheng, Caroline Bennett, Jie Han, and Robert L. Parsons. 2012. Integrated analysis of the performance of pile-supported bridges under scoured conditions. *Engineering Structures* 36: 27-38.
- Maddison, Brian. 2012. Scour failure of bridges. *Forensic Engineering* 165, Issue FE1: 39-52.
- McConnell, Jennifer Righman and Michael Cann. 2011. Coupled field monitoring and structural analysis to assess scour conditions. *Journal of Performance of Constructed Facilities*. American Society of Civil Engineers. (in press).
- Ramey, G.E. and A.P. Hudgins. June 1975. Modification of pile capacity and length prediction equations based on historical Alabama pile test data. *Alabama Department of Transportation HPR Report No. 75*.

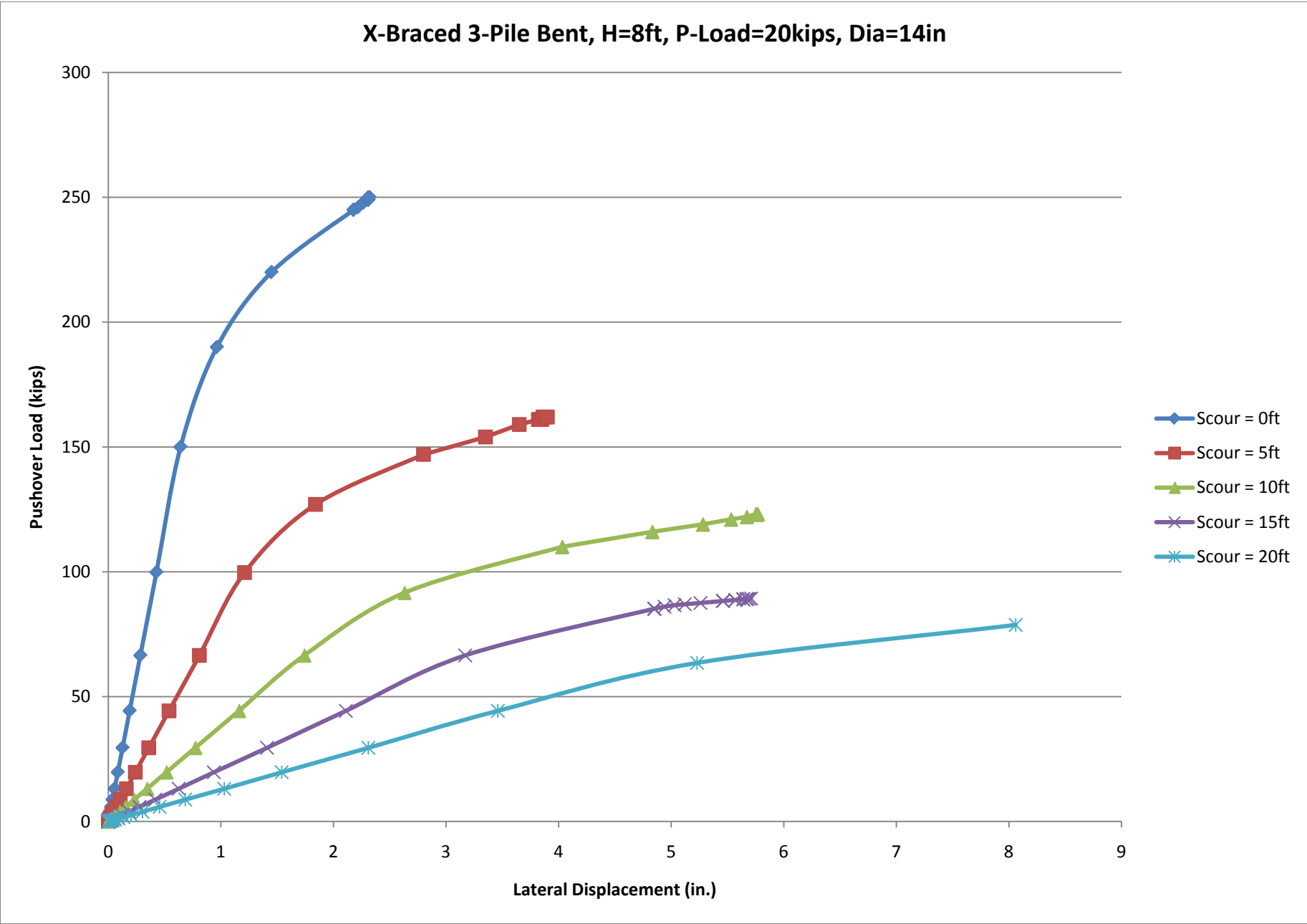
- Ramey, G.E. and D.A. Brown. 2004. Stability of Highway Bridges Subject to Scour - Phase I, Alabama Department of Transportation Project No. 930-585, Final Report. Auburn University, Alabama: Highway Research Center.
- Ramey, G.E., D.A. Brown, D. Hughes, J. Daniels, and L. Agnew. 2006. Stability of Highway Bridges Subject to Scour - Phase II, Alabama Department of Transportation Project No. 930-608, Final Report. Auburn University, Alabama: Highway Research Center.
- Ramey, G.E., D.A. Brown, M.L. Hughes, D. Hughes, J. Daniels. 2007. Screening Tool to Assess Adequacy of Bridge Pile Bents during Extreme Flood/Scour Events. *ASCE: Practice Periodical on Structural Design and Construction* 12, no. 2: 109-121.
- Ramey, G.E., M.L. Hughes, D.A. Brown, N. Donnee, and N. Walker. May 2008. Stability of Highway Bridges Subject to Scour - Phase III – Part 1, Alabama Department of Transportation Project No. 930-674. Auburn University, Alabama: Highway Research Center.
- Ramey, G.E., M.L. Hughes, Mary Schambeau, Junsuk Kang, and James S. Davidson. 2011. Stability of Highway Bridges Subject to Scour – Phase IV – Part 1, Alabama Department of Transportation Project No. 930-776. Auburn University, Alabama: Highway Research Center.
- Shaeffer, R.E. 1980. *Building Structures: Elementary Analysis and Design*. Englewood Cliffs, New Jersey: Prentice-Hall Inc.
- Simulia. ABAQUS Analysis User's Manual. Version 6.7. 2007. ABAQUS, Inc.

- Quintero, P.S. March 1980. *Windspeed Analysis of the North Birmingham, Alabama Tornado of April 4, 1977*. MSCE Thesis, Auburn University.
- Yu, Wei and Wei Zheng. 2012. Probabilistic computational framework for detecting bridge scour damages based on in-situ measurement. TRB 2012 Annual Meeting. Transportation Research Board. (in press).
- Zmeu, Bogdan, P.E. April 2012. Evaluation of timber foundation piling in marine applications: knowledge based computerizes algorithms for pile evaluation analysis. *Structure Magazine*.

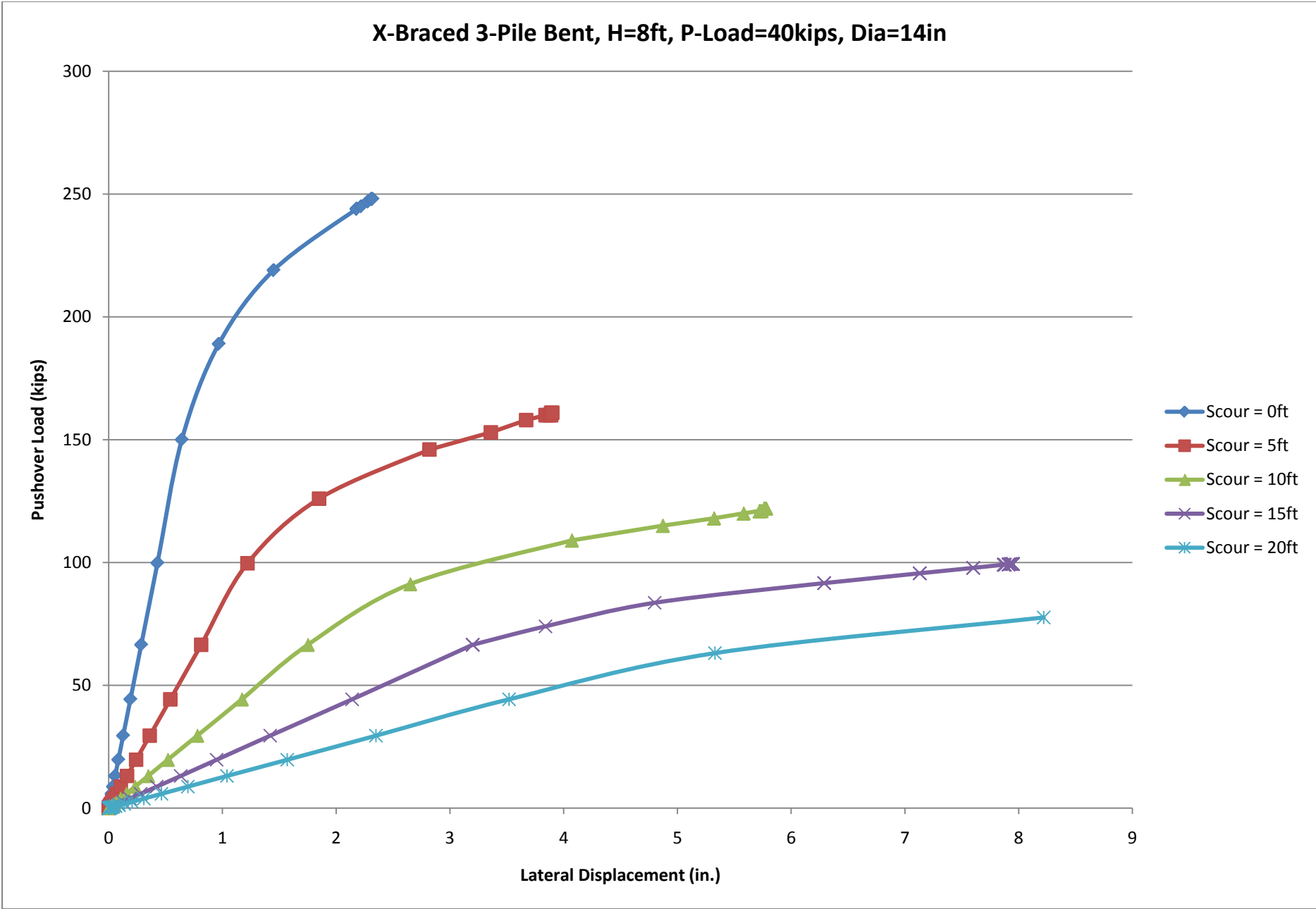
## **APPENDIX A**

### **X-Braced Timber Pile Bent**

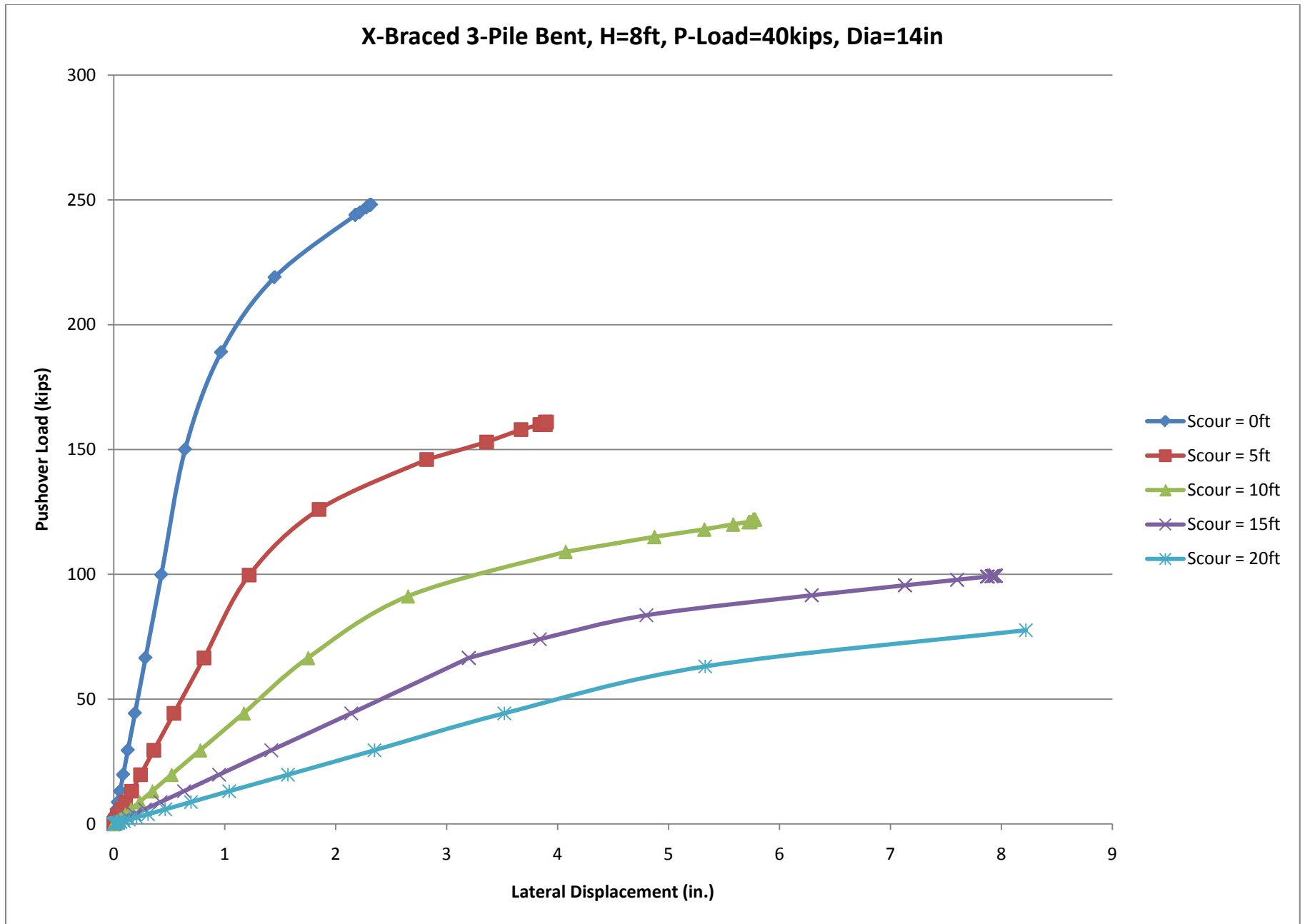
#### **$F_t$ vs $\Delta$ Pushover Curves**



**Figure A.1 Pushover Curves for X-Braced 3-Pile Bent, H=8ft, P=20kips, Diameter=14in, Multiple Levels of Scour**



**Figure A.2 Pushover Curves for X-Braced 3-Pile Bent, H=8ft, P=40kips, Diameter=14in, Multiple Levels of Scour**



**Figure A.2 Pushover Curves for X-Braced 3-Pile Bent, H=8ft, P=40kips, Diameter=14in, Multiple Levels of Scour**



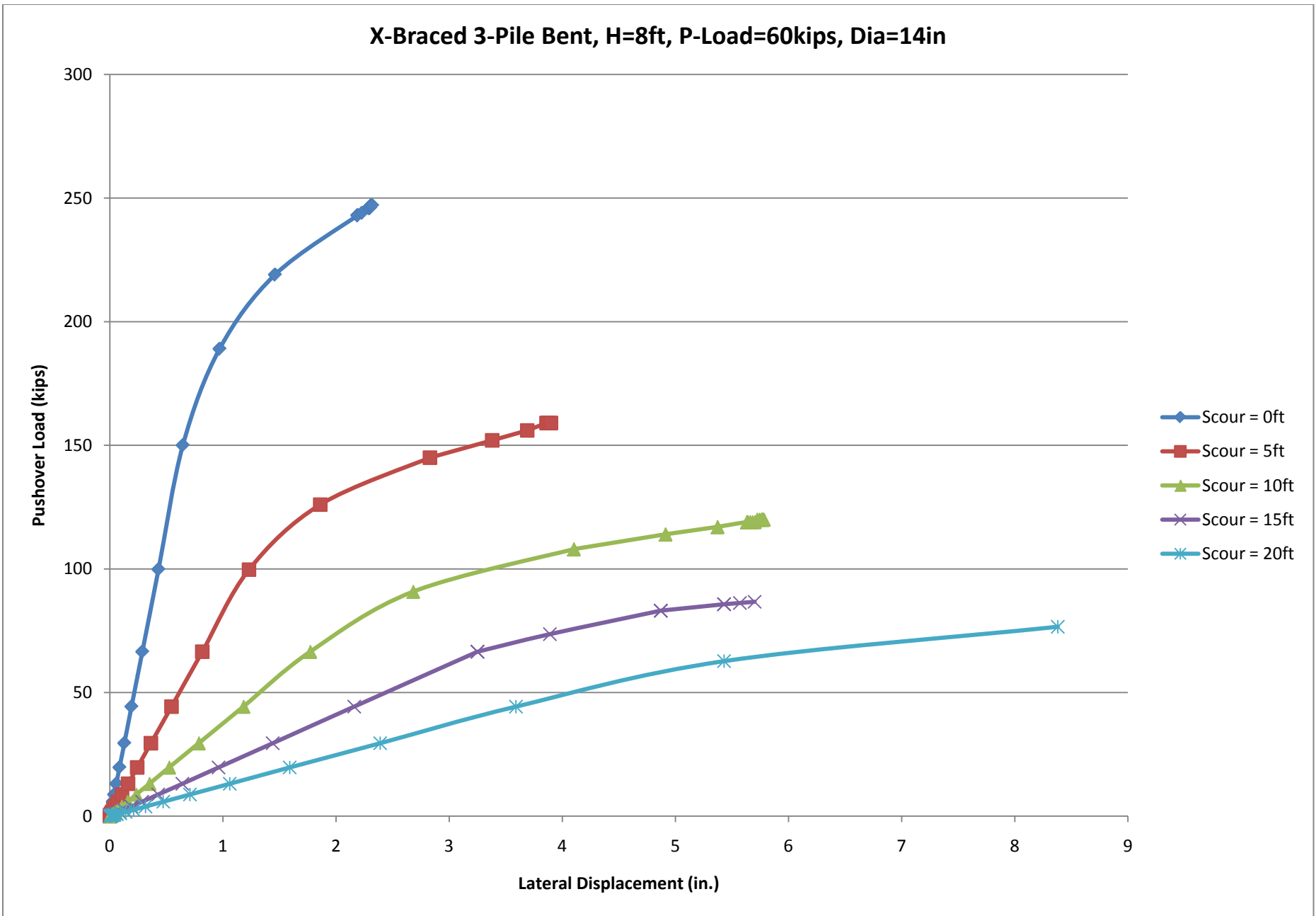


Figure A.3 Pushover Curves for X-Braced 3-Pile Bent, H=8ft, P=60kips, Diameter=14in, Multiple Levels of Scour

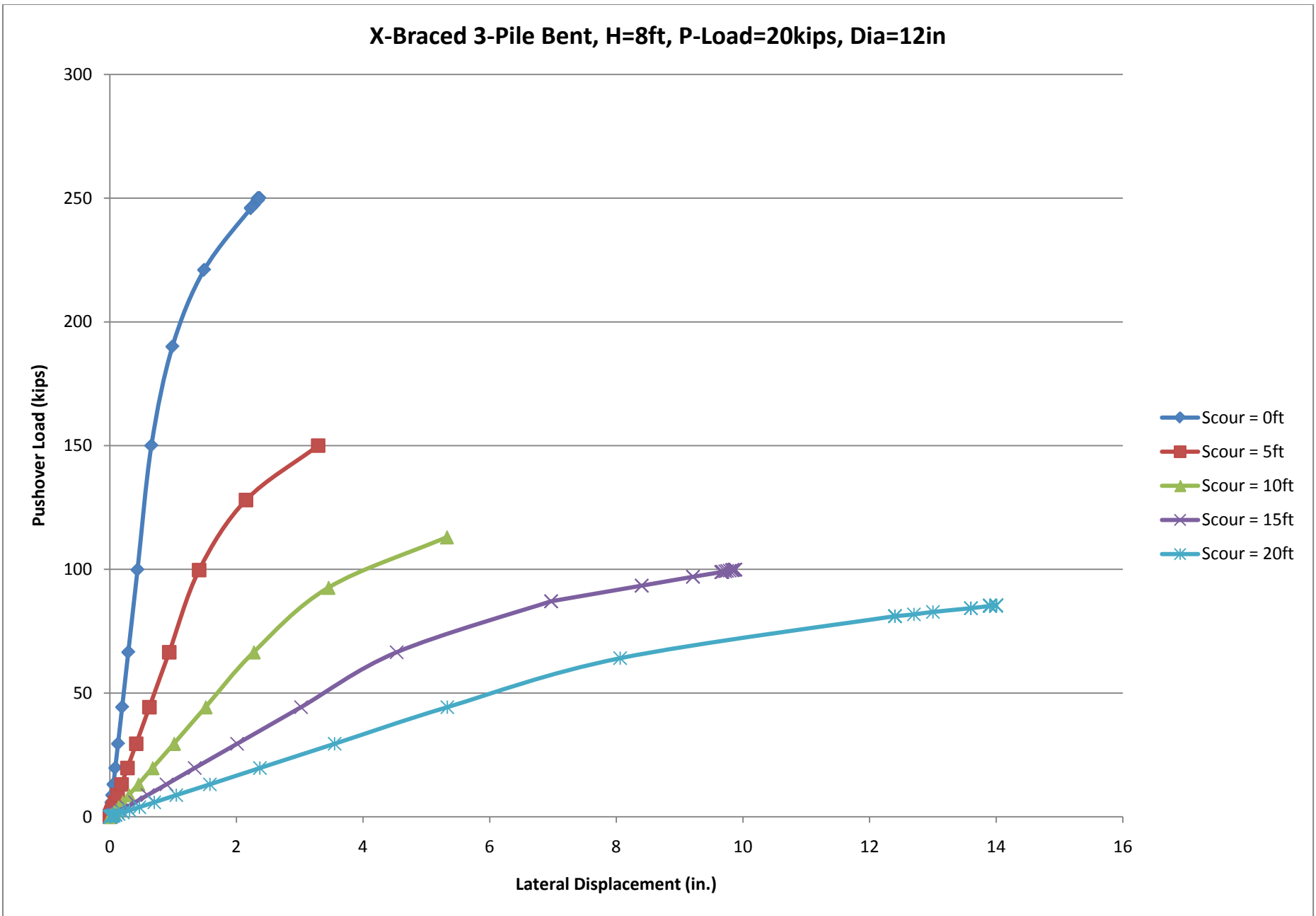
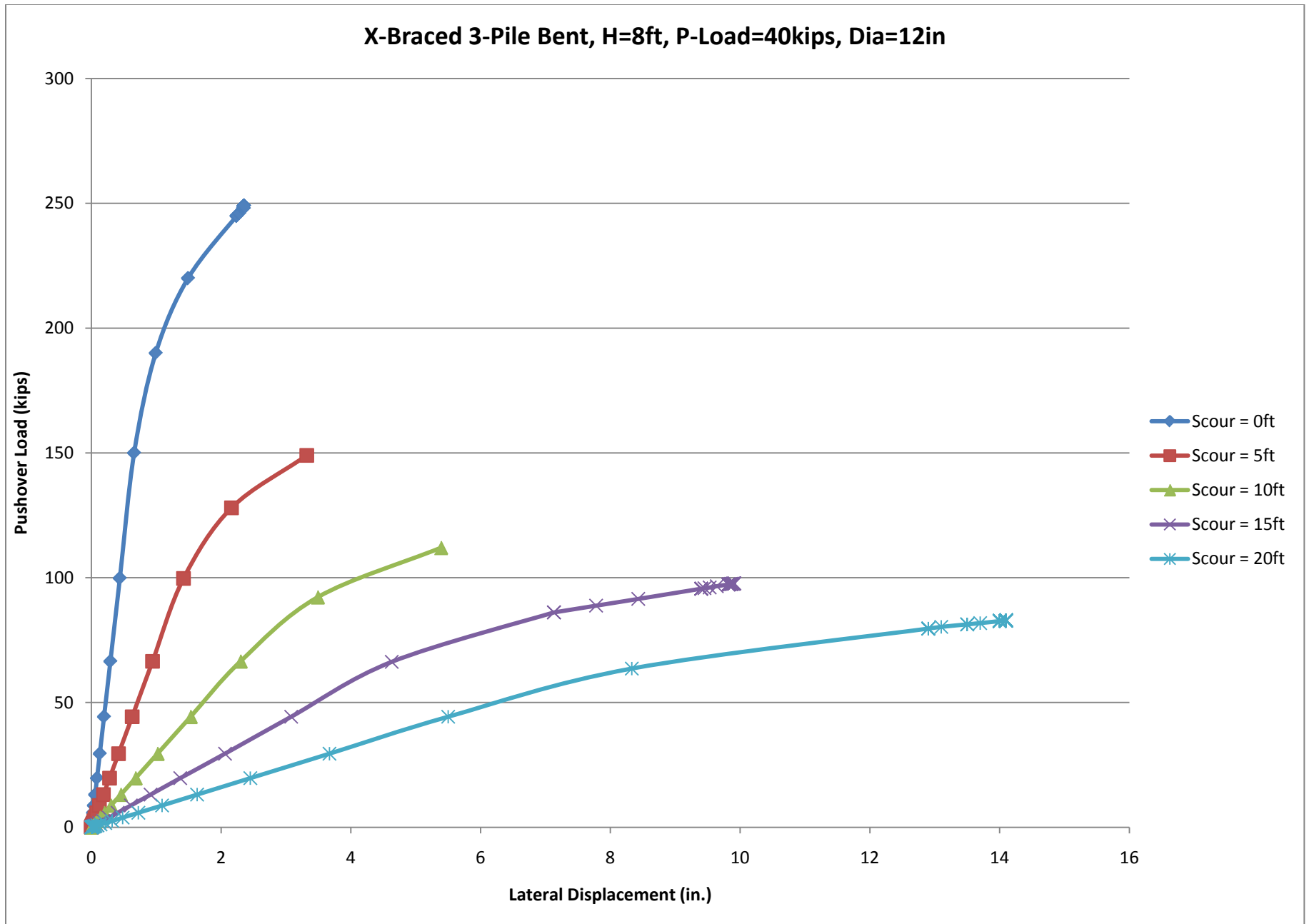


Figure A.4 Pushover Curves for X-Braced 3-Pile Bent, H=8ft, P=20kips, Diameter=12in, Multiple Levels of Scour



**Figure A.5 Pushover Curves for X-Braced 3-Pile Bent, H=8ft, P=40kips, Diameter=12in, Multiple Levels of Scour**

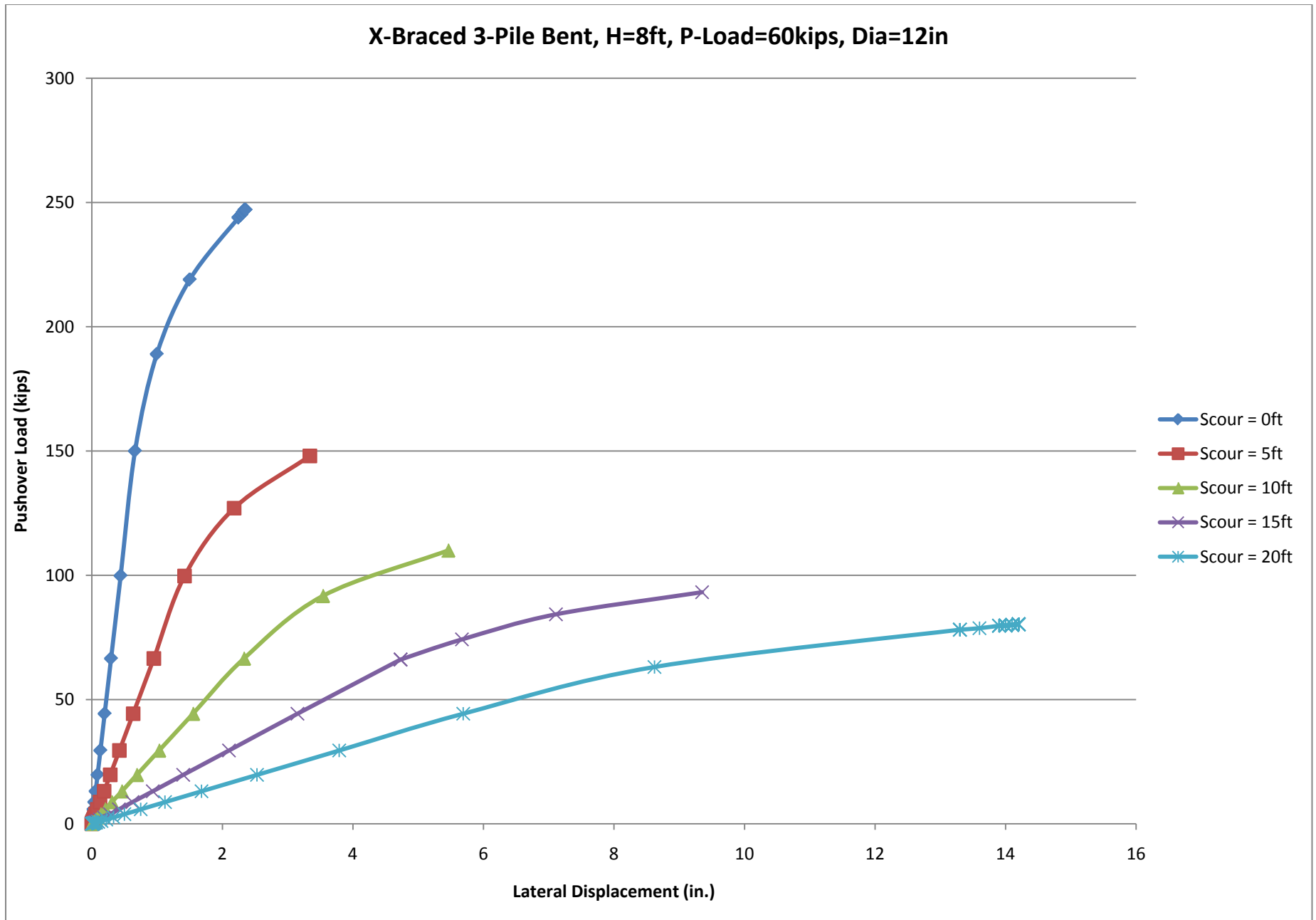
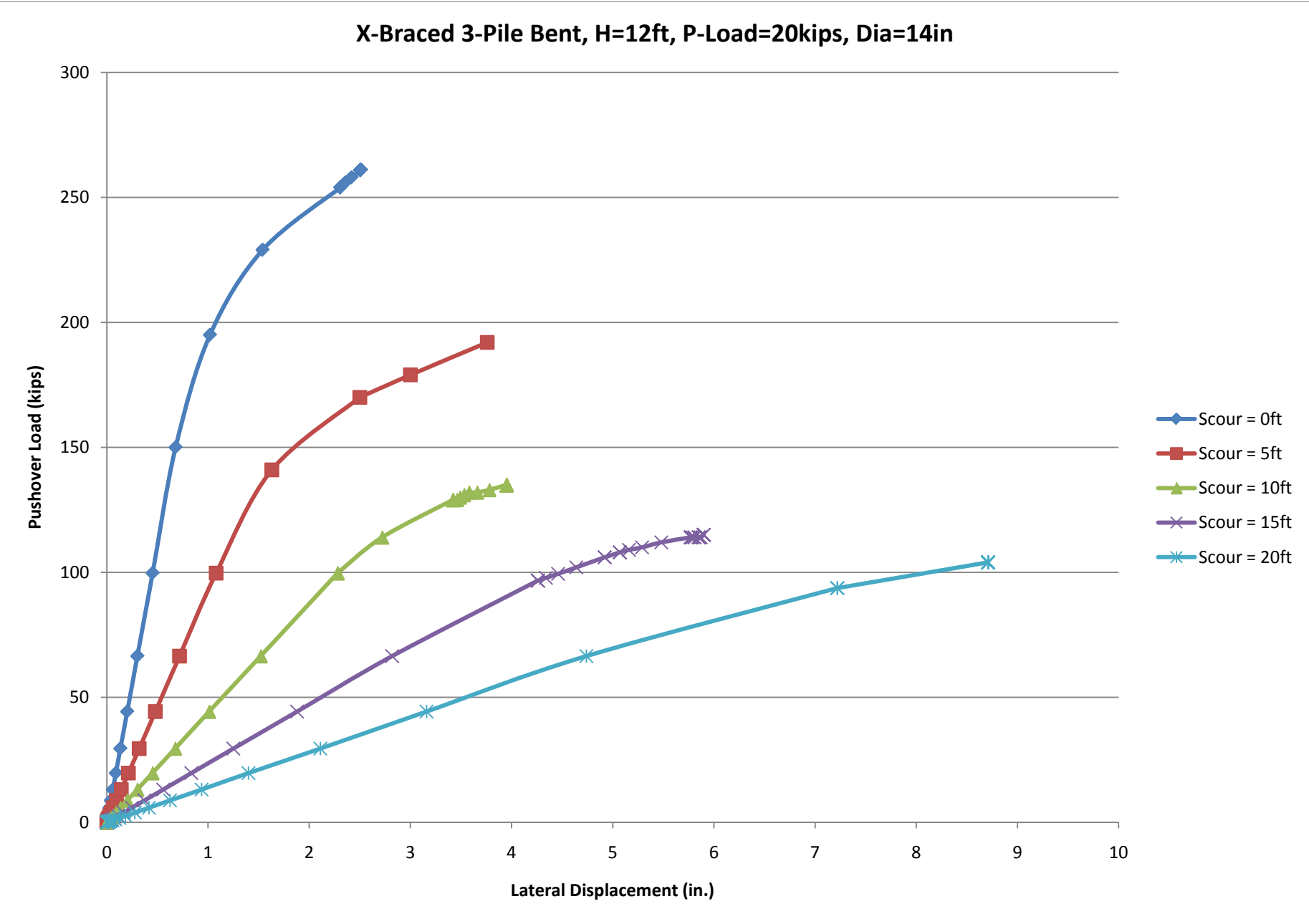
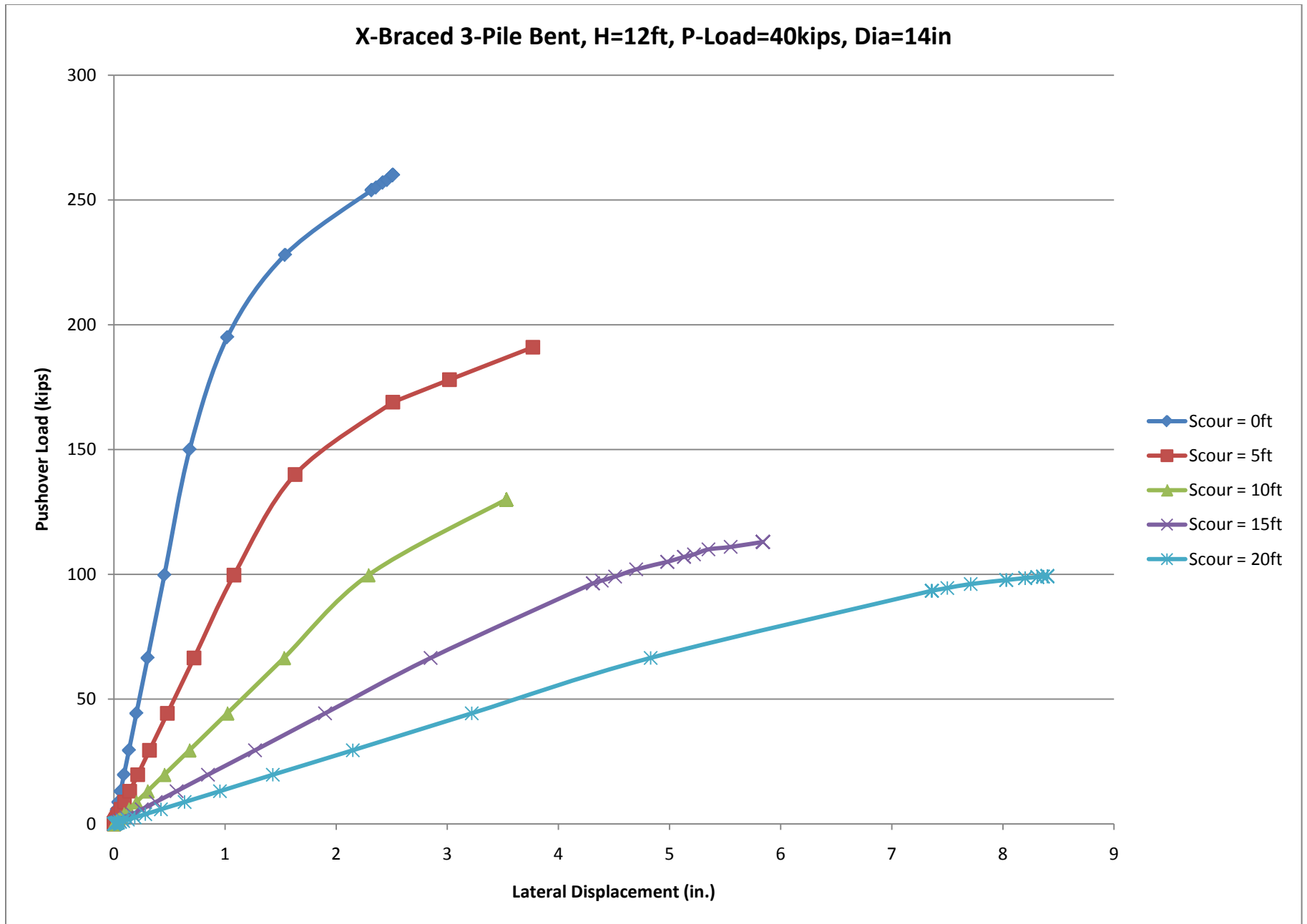


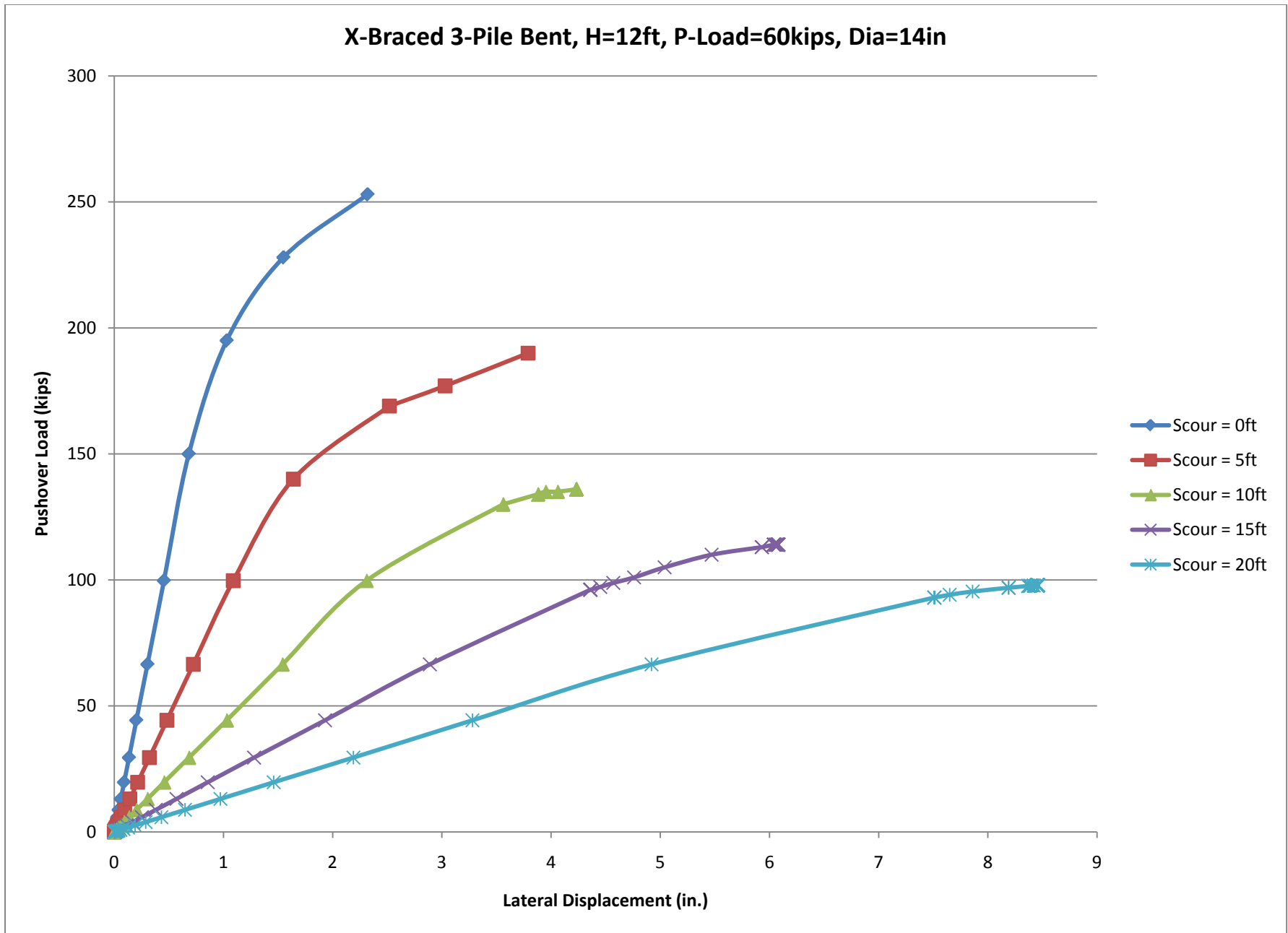
Figure A.6 Pushover Curves for X-Braced 3-Pile Bent, H=8ft, P=60kips, Diameter=12in, Multiple Levels of Scour



**Figure A.7 Pushover Curves for X-Braced 3-Pile Bent, H=12ft, P=20kips, Diameter=14in, Multiple Levels of Scour**



**Figure A.8 Pushover Curves for X-Braced 3-Pile Bent, H=12ft, P=40kips, Diameter=14in, Multiple Levels of Scour**



**Figure A.9 Pushover Curves for X-Braced 3-Pile Bent, H=12ft, P=60kips, Diameter=14in, Multiple Levels of Scour**

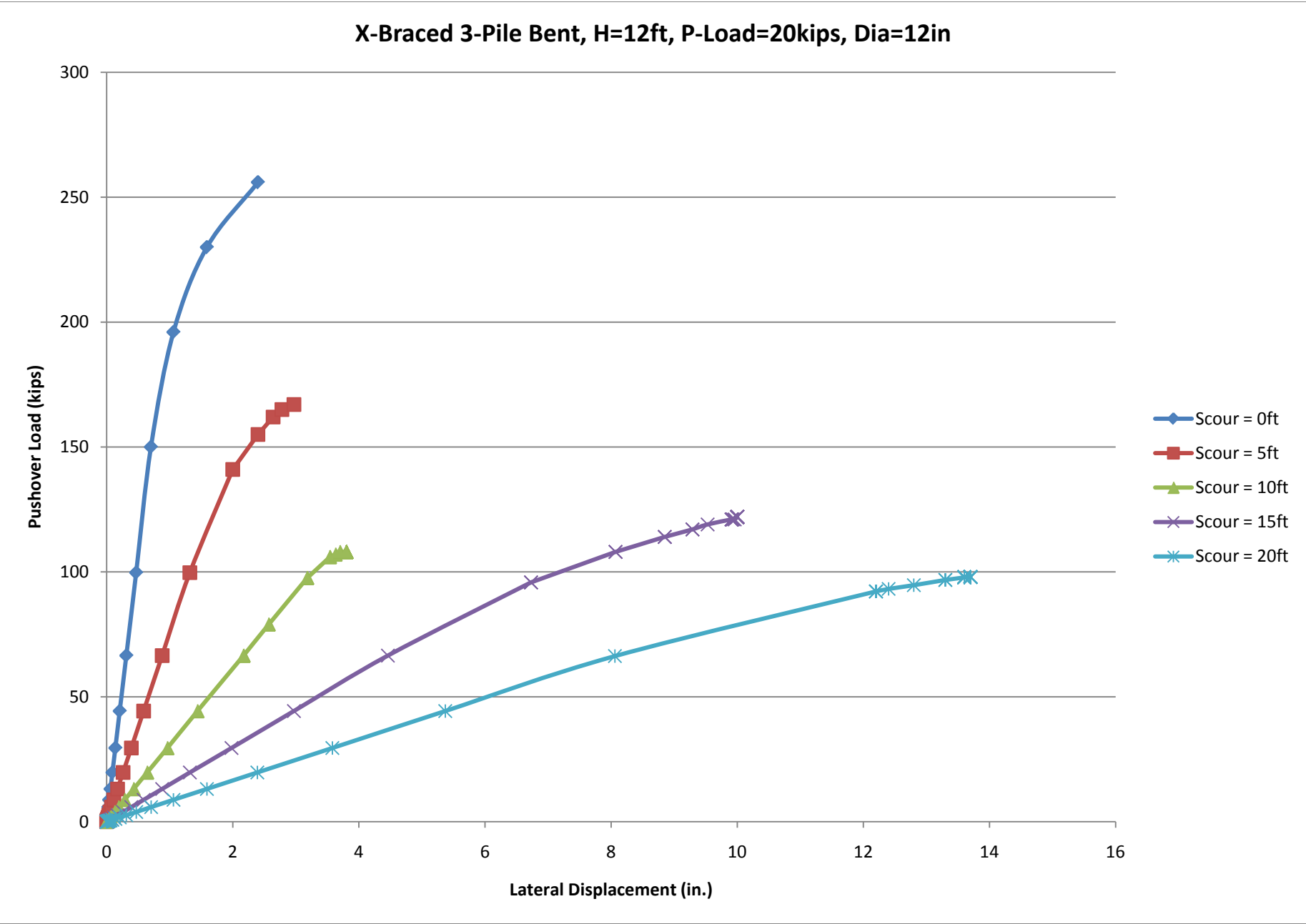


Figure A.10 Pushover Curves for X-Braced 3-Pile Bent, H=12ft, P=20kips, Diameter=12in, Multiple Levels of Scour



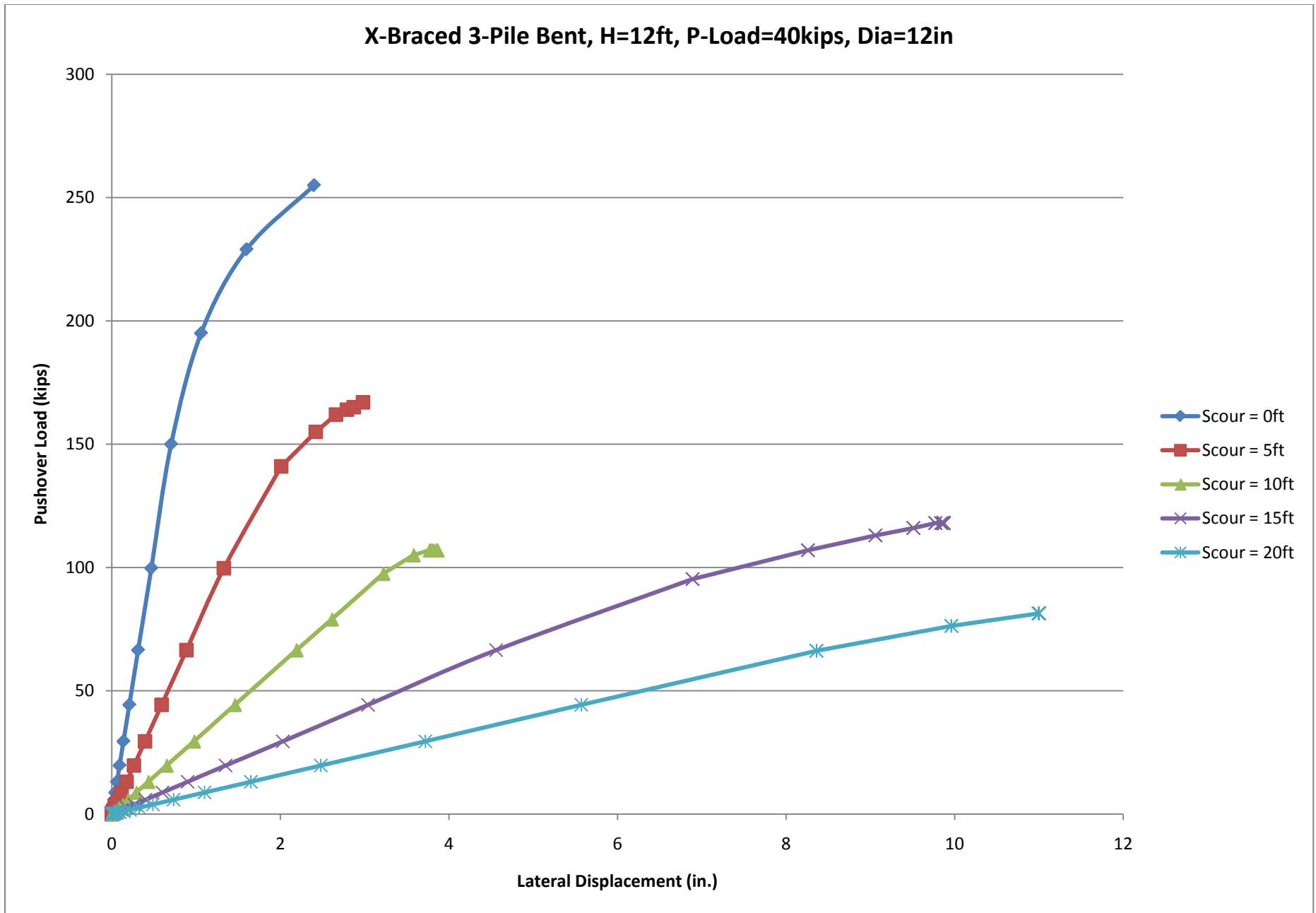
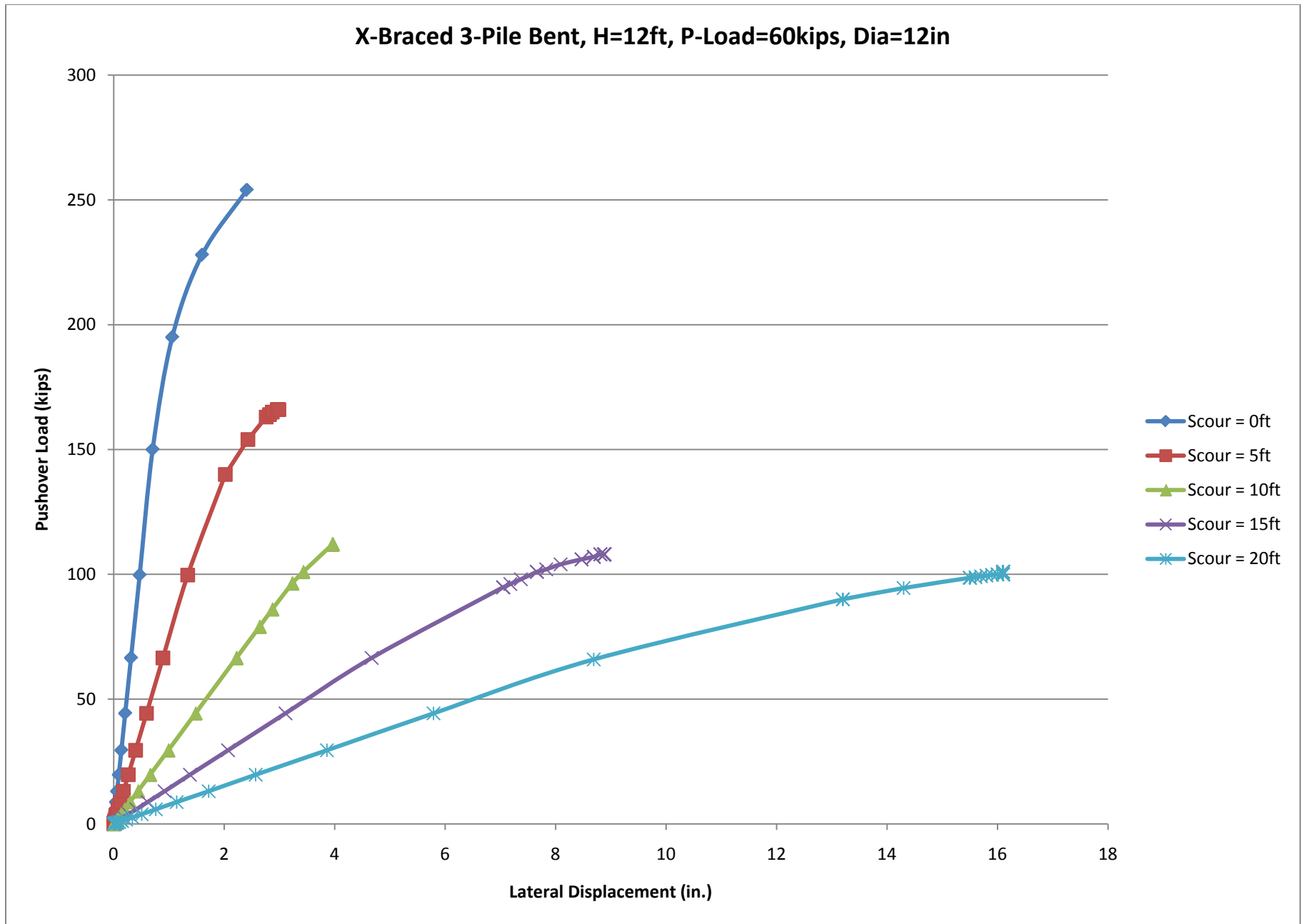


Figure A.11 Pushover Curves for X-Braced 3-Pile Bent, H=12ft, P=40kips, Diameter=12in, Multiple Levels of Scour



**Figure A.12 Pushover Curves for X-Braced 3-Pile Bent, H=12ft, P=60kips, Diameter=12in, Multiple Levels of Scour**

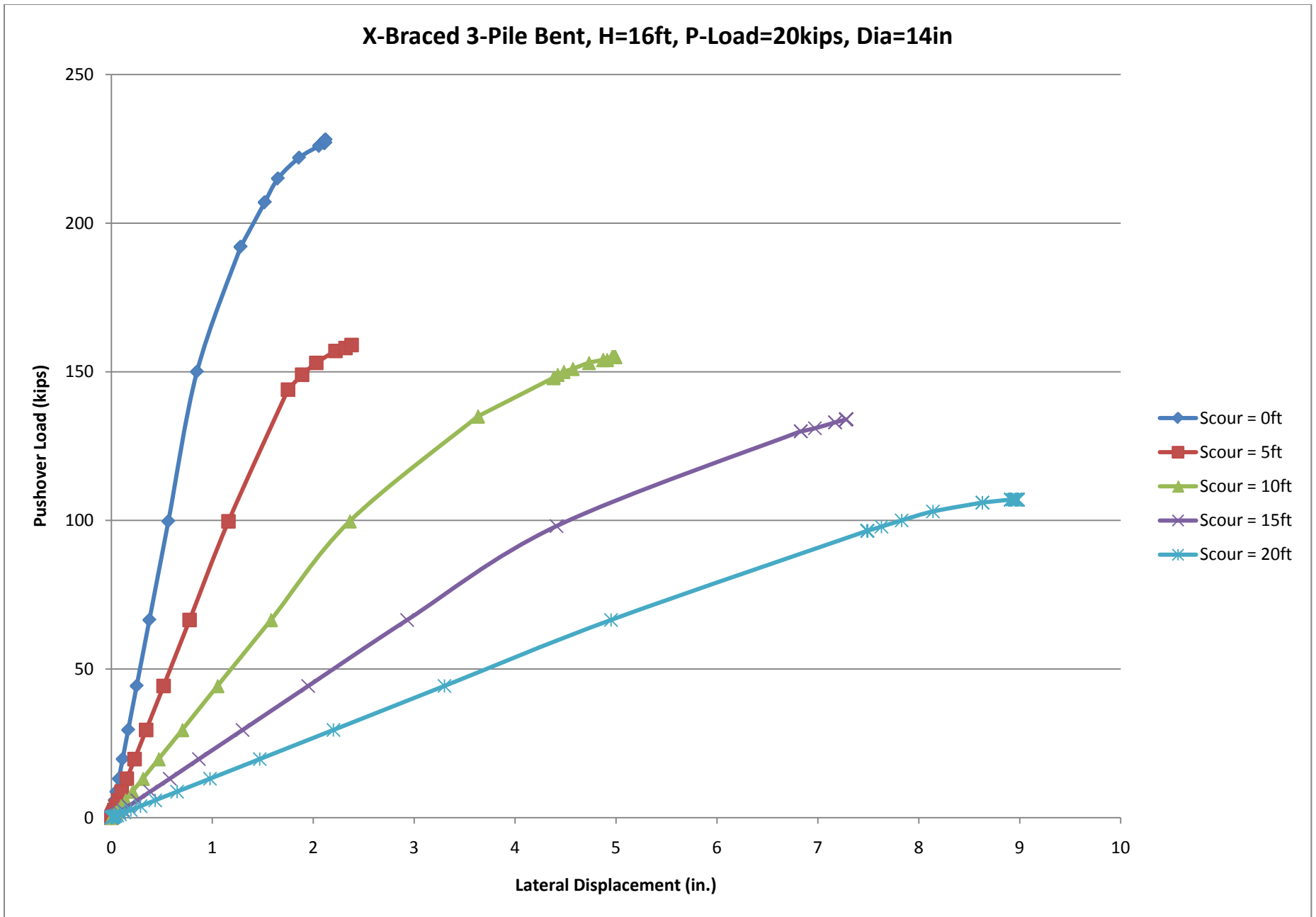


Figure A.13 Pushover Curves for X-Braced 3-Pile Bent, H=16ft, P=20kips, Diameter=14in, Multiple Levels of Scour

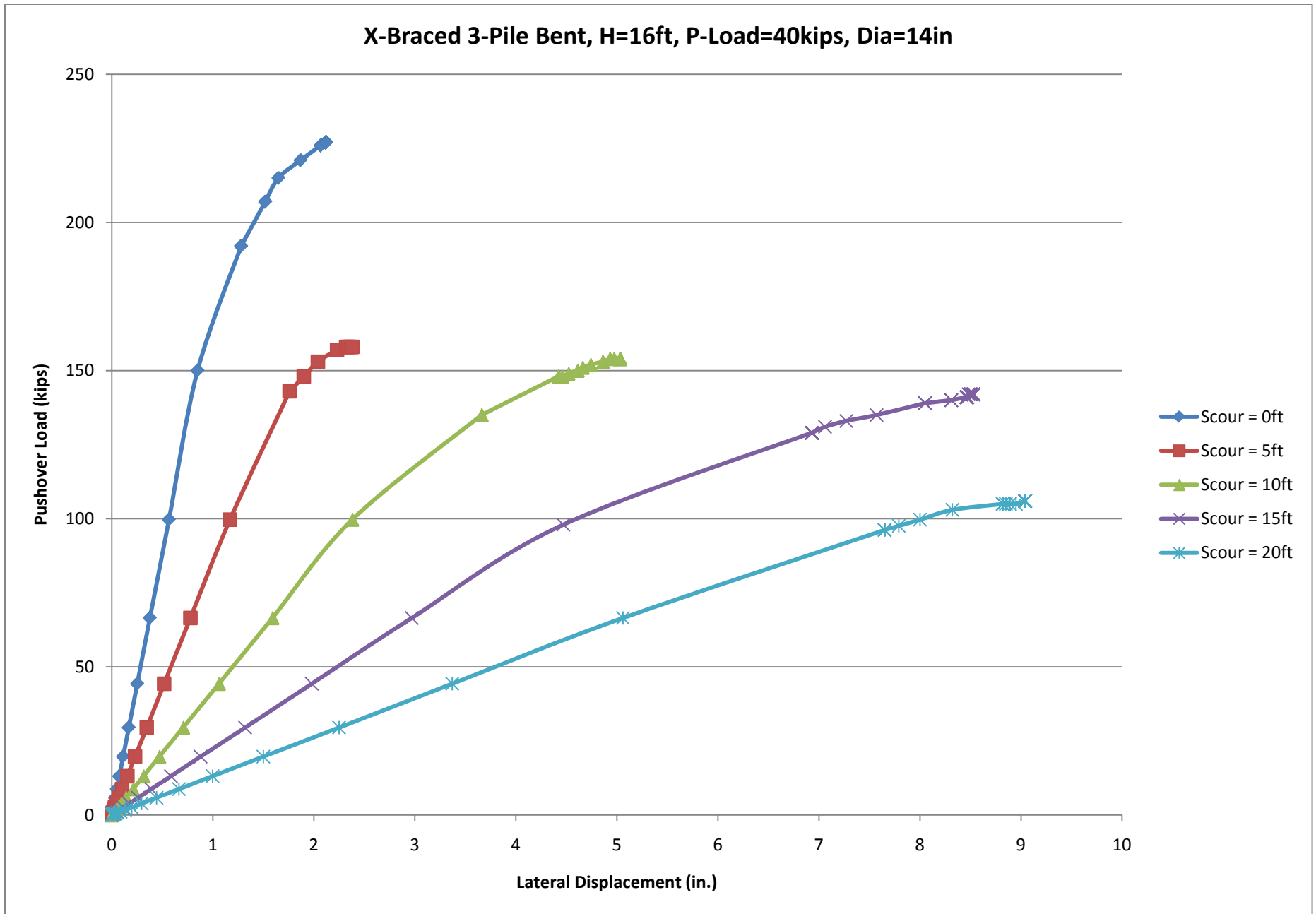
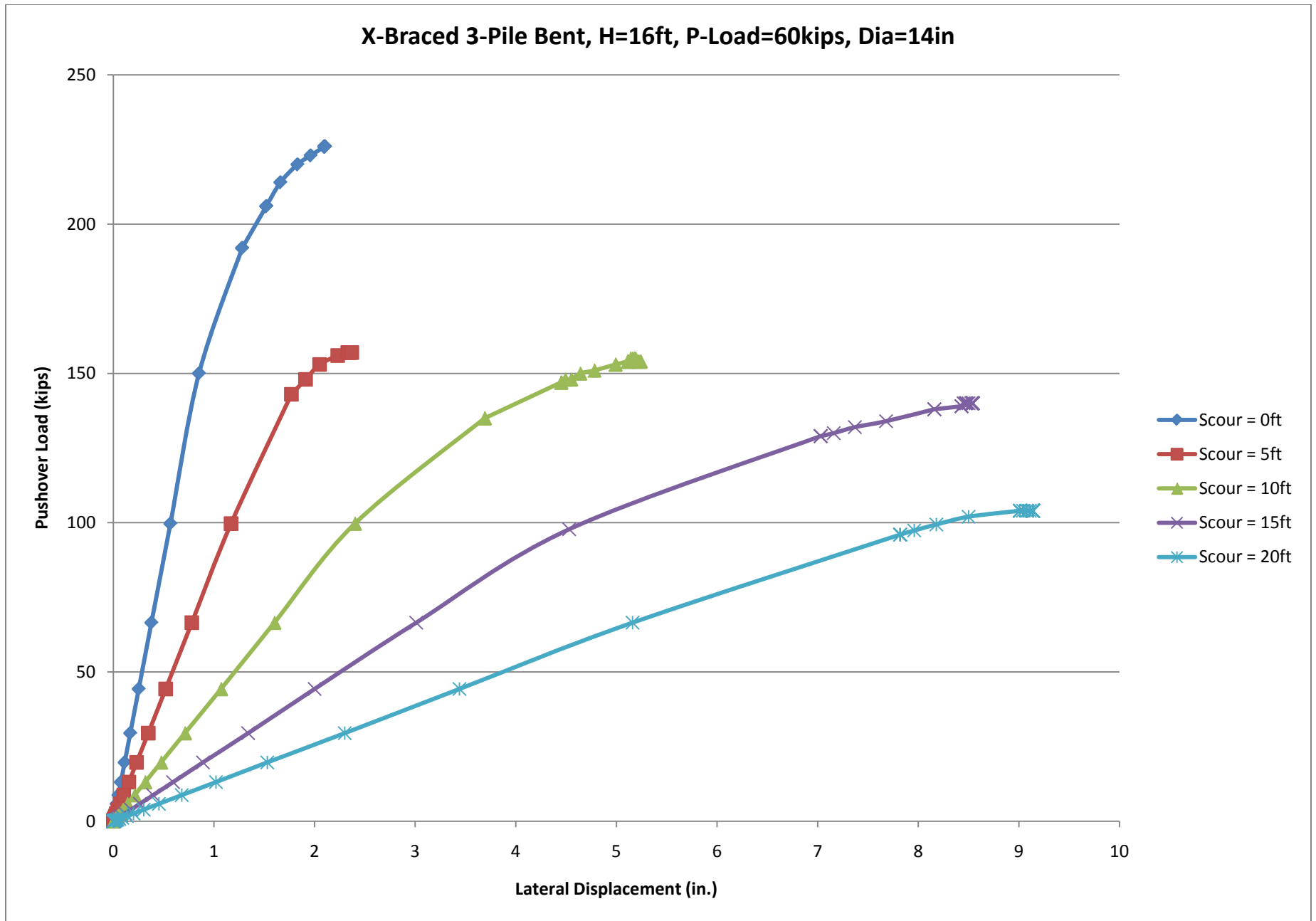
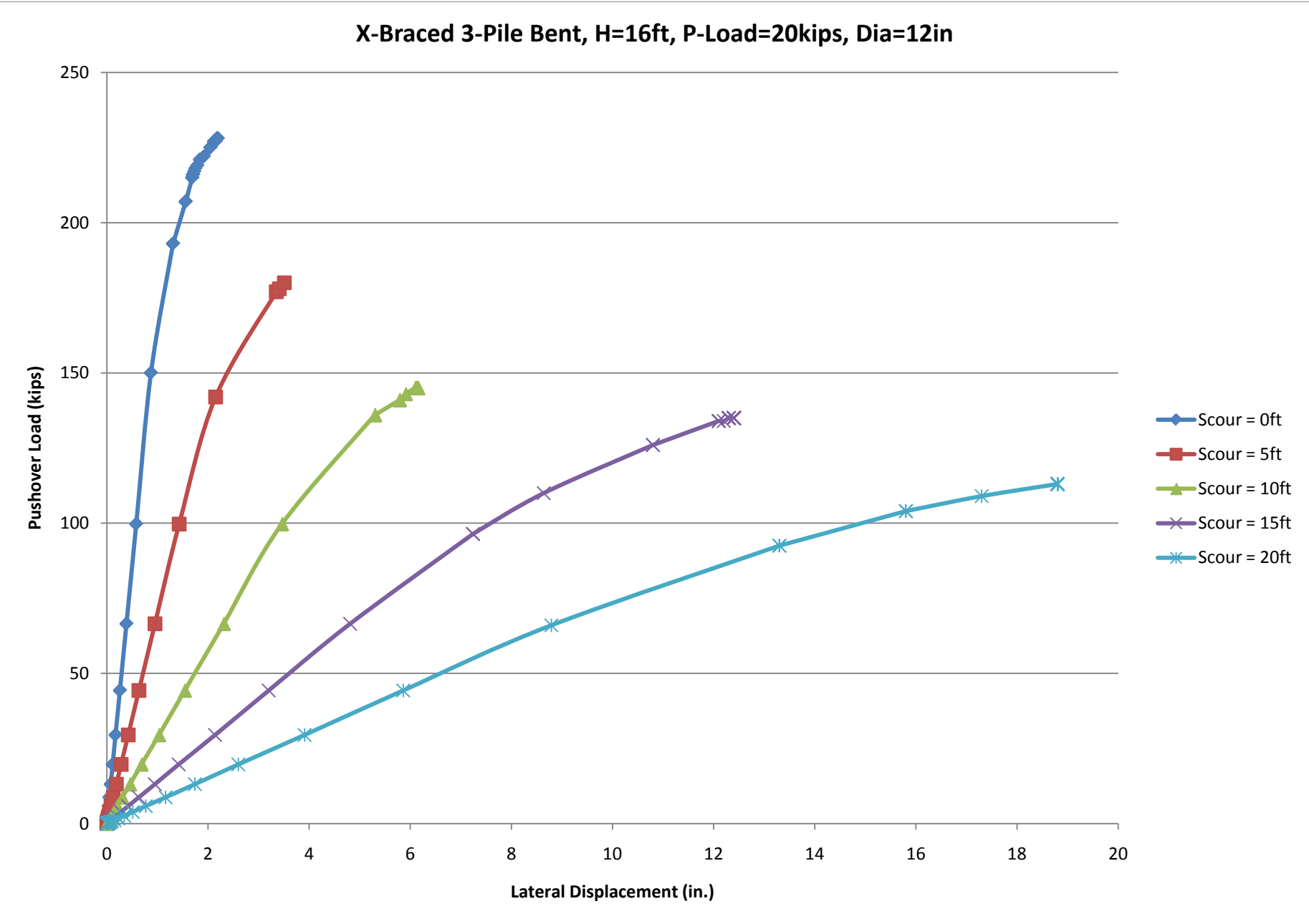


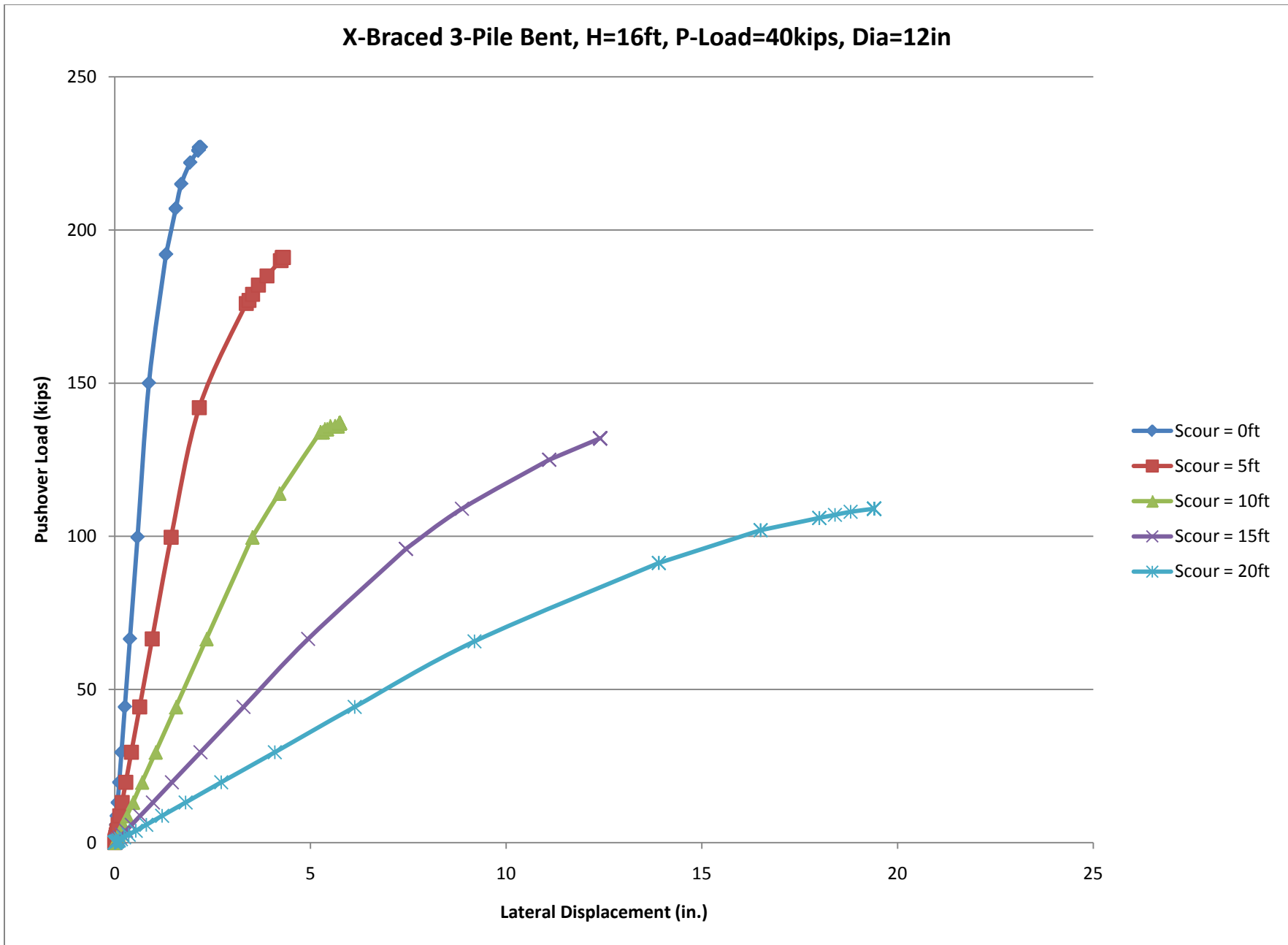
Figure A.14 Pushover Curves for X-Braced 3-Pile Bent, H=16ft, P=40kips, Diameter=14in, Multiple Levels of Scour



**Figure A.15 Pushover Curves for X-Braced 3-Pile Bent, H=16ft, P=60kips, Diameter=14in, Multiple Levels of Scour**



**Figure A.16 Pushover Curves for X-Braced 3-Pile Bent, H=16ft, P=20kips, Diameter=12in, Multiple Levels of Scour**  
167



**Figure A.17 Pushover Curves for X-Braced 3-Pile Bent, H=16ft, P=40kips, Diameter=12in, Multiple Levels of Scour**  
168

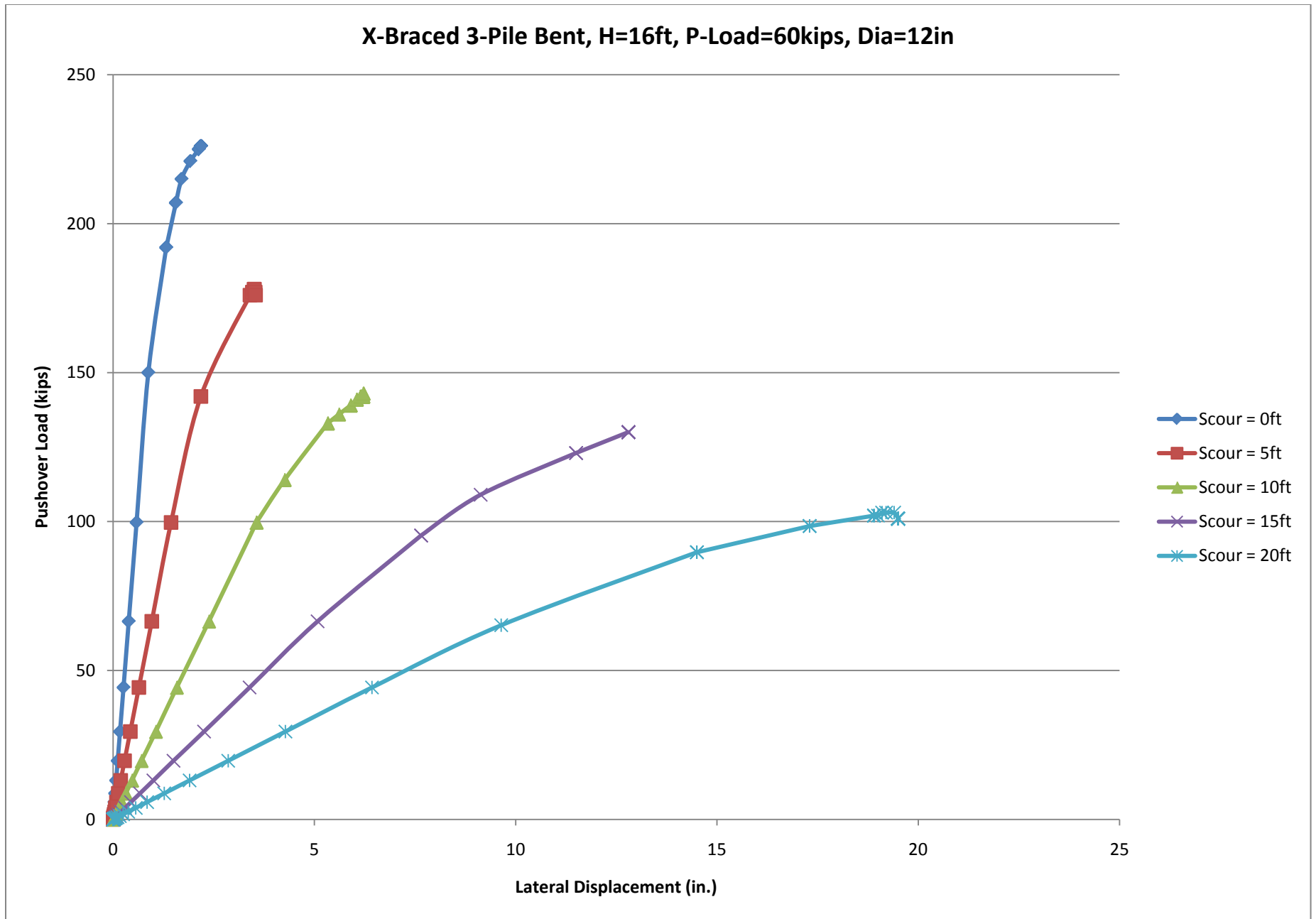
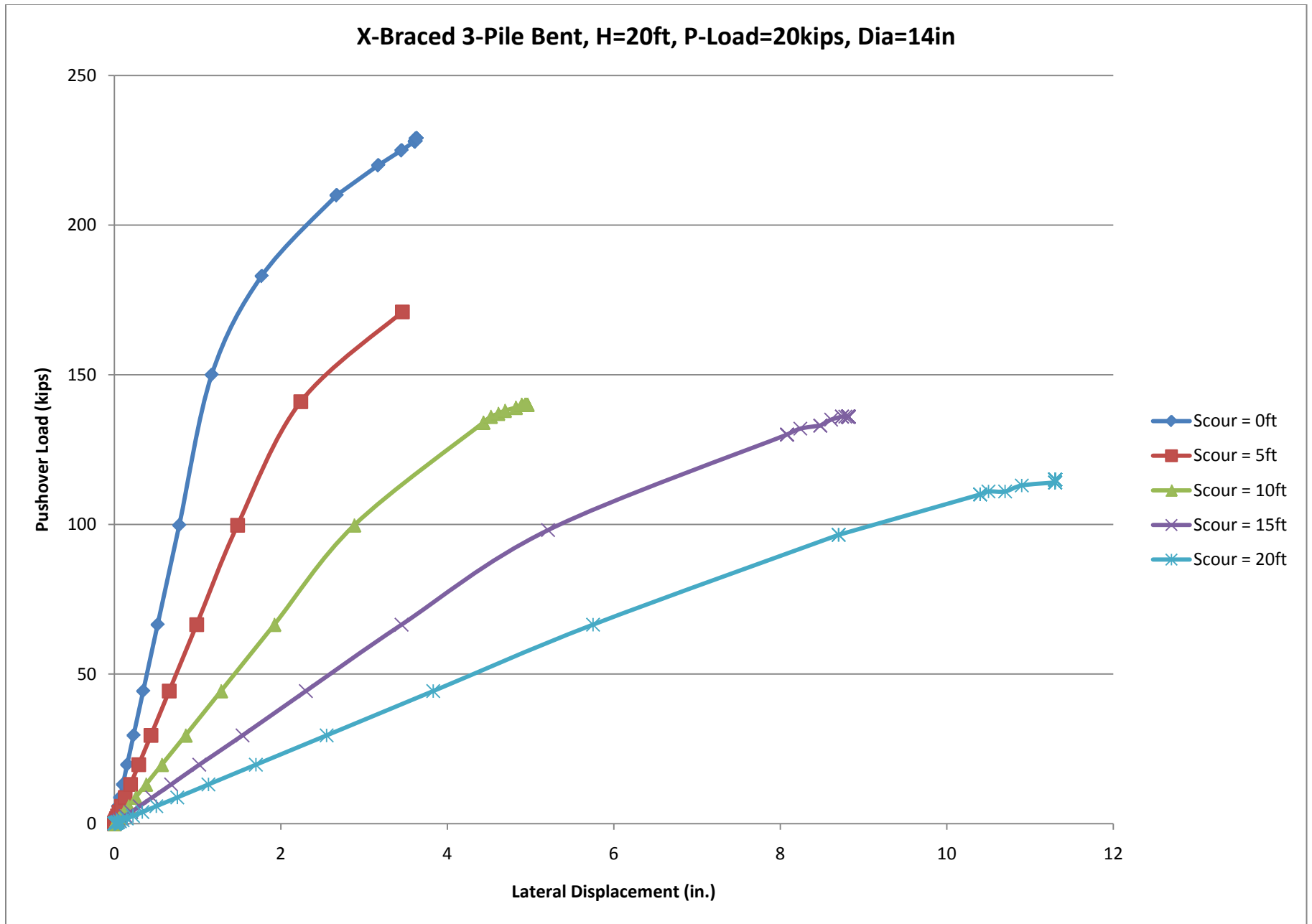
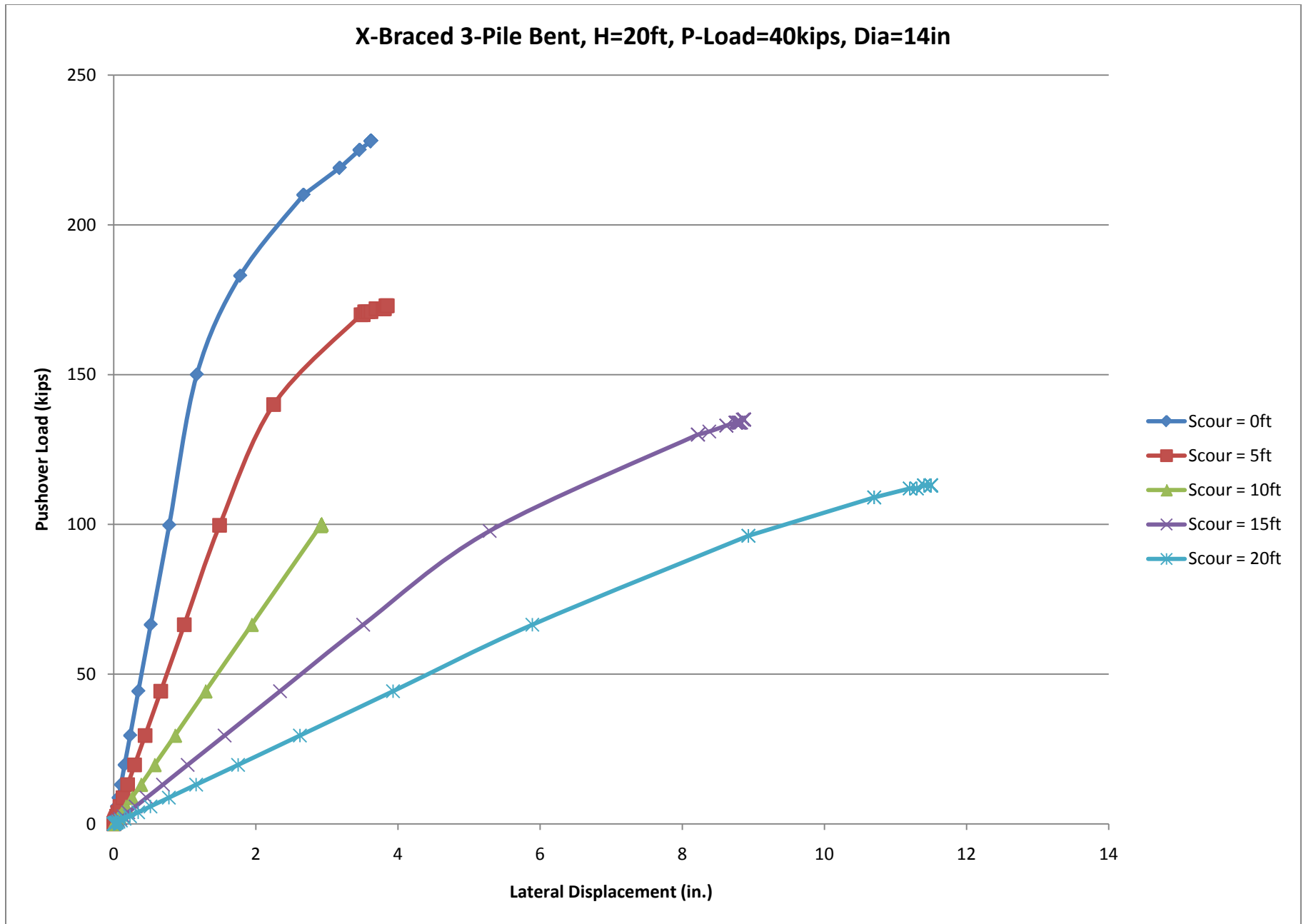


Figure A.18 Pushover Curves for X-Braced 3-Pile Bent, H=16ft, P=60kips, Diameter=12in, Multiple Levels of Scour





**Figure A.19 Pushover Curves for X-Braced 3-Pile Bent, H=20ft, P=20kips, Diameter=14in, Multiple Levels of Scour**



**Figure A.20 Pushover Curves for X-Braced 3-Pile Bent, H=20ft, P=40kips, Diameter=14in, Multiple Levels of Scour**

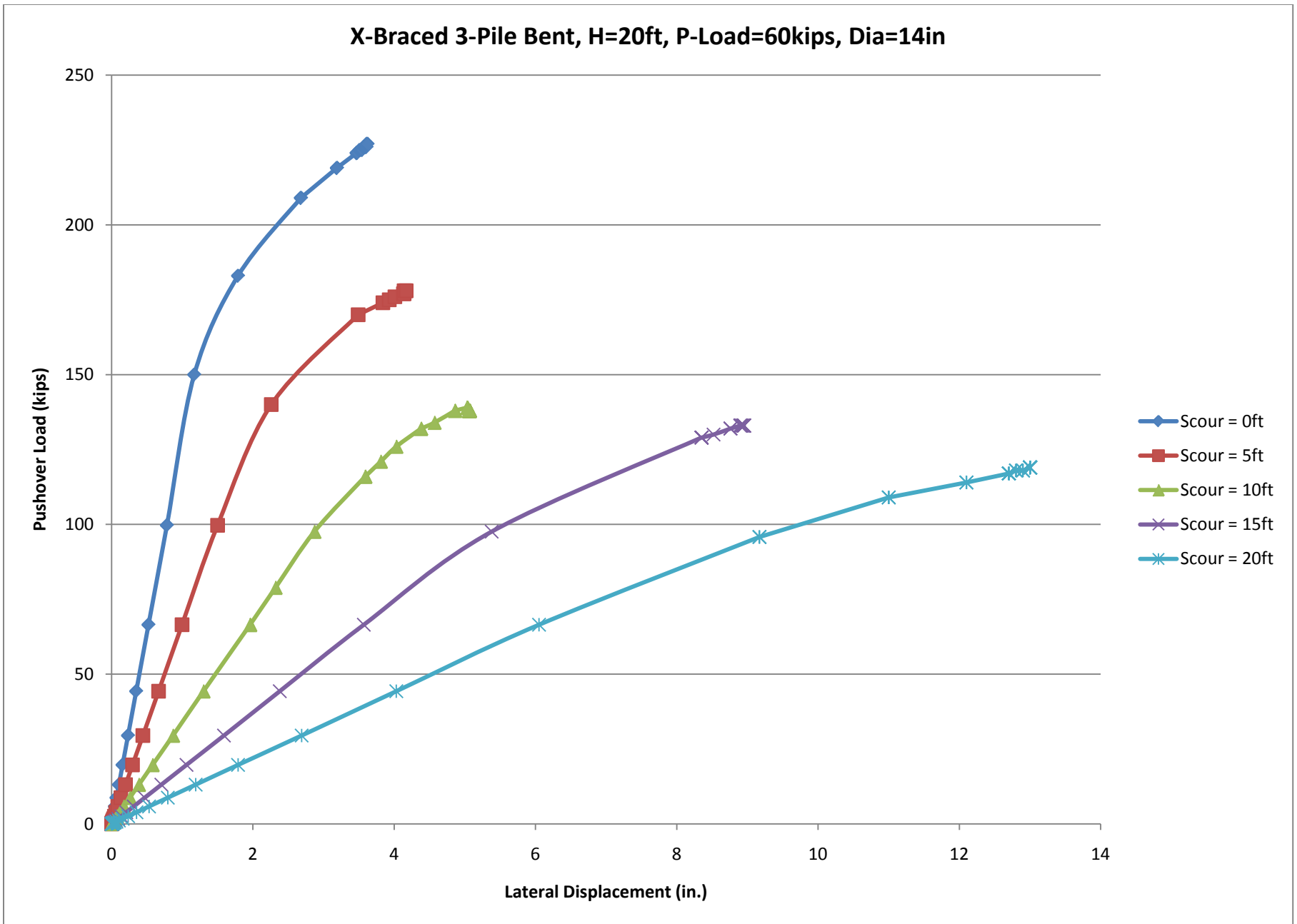


Figure A.21 Pushover Curves for X-Braced 3-Pile Bent, H=20ft, P=60kips, Diameter=14in, Multiple Levels of Scour

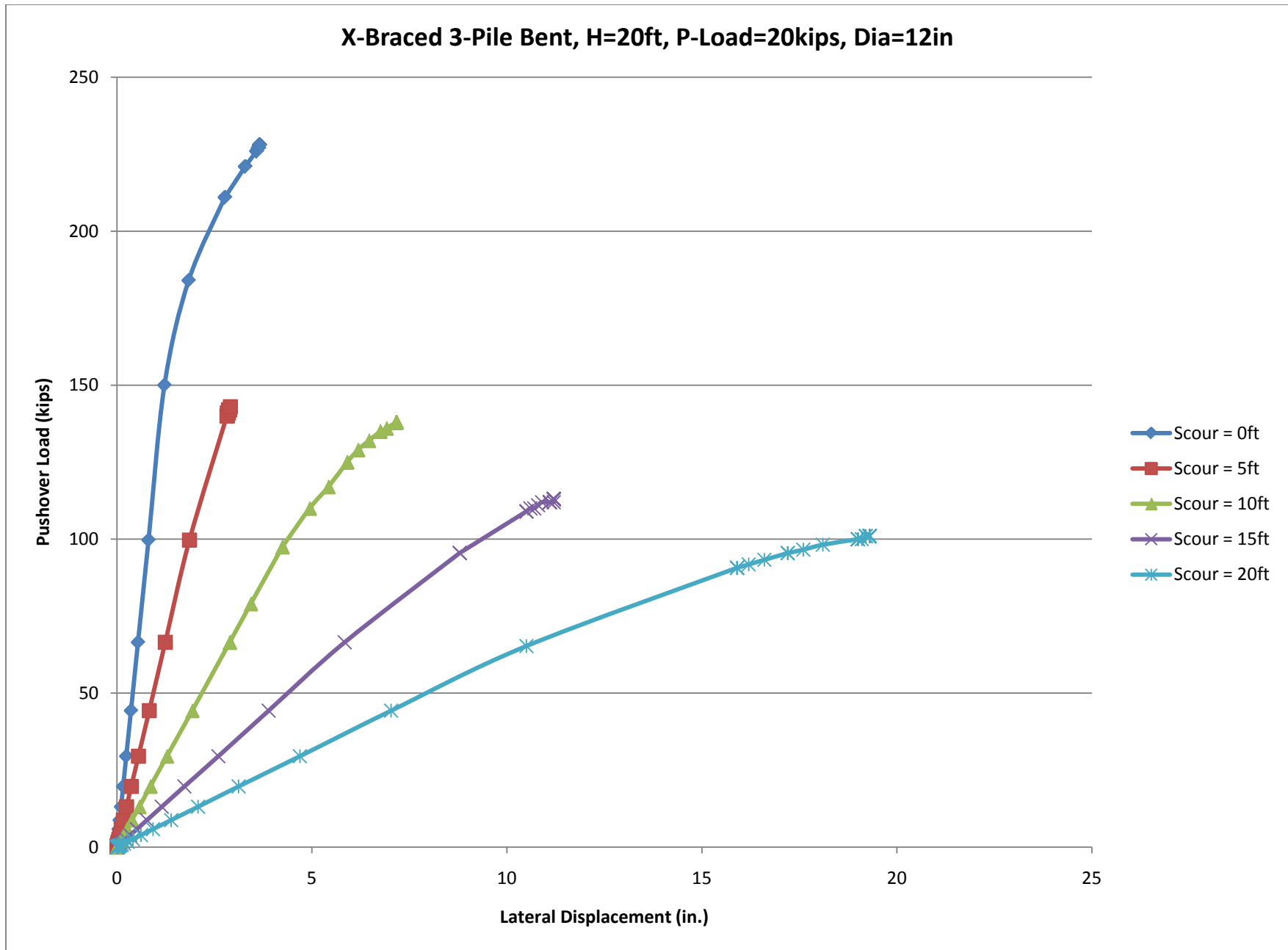
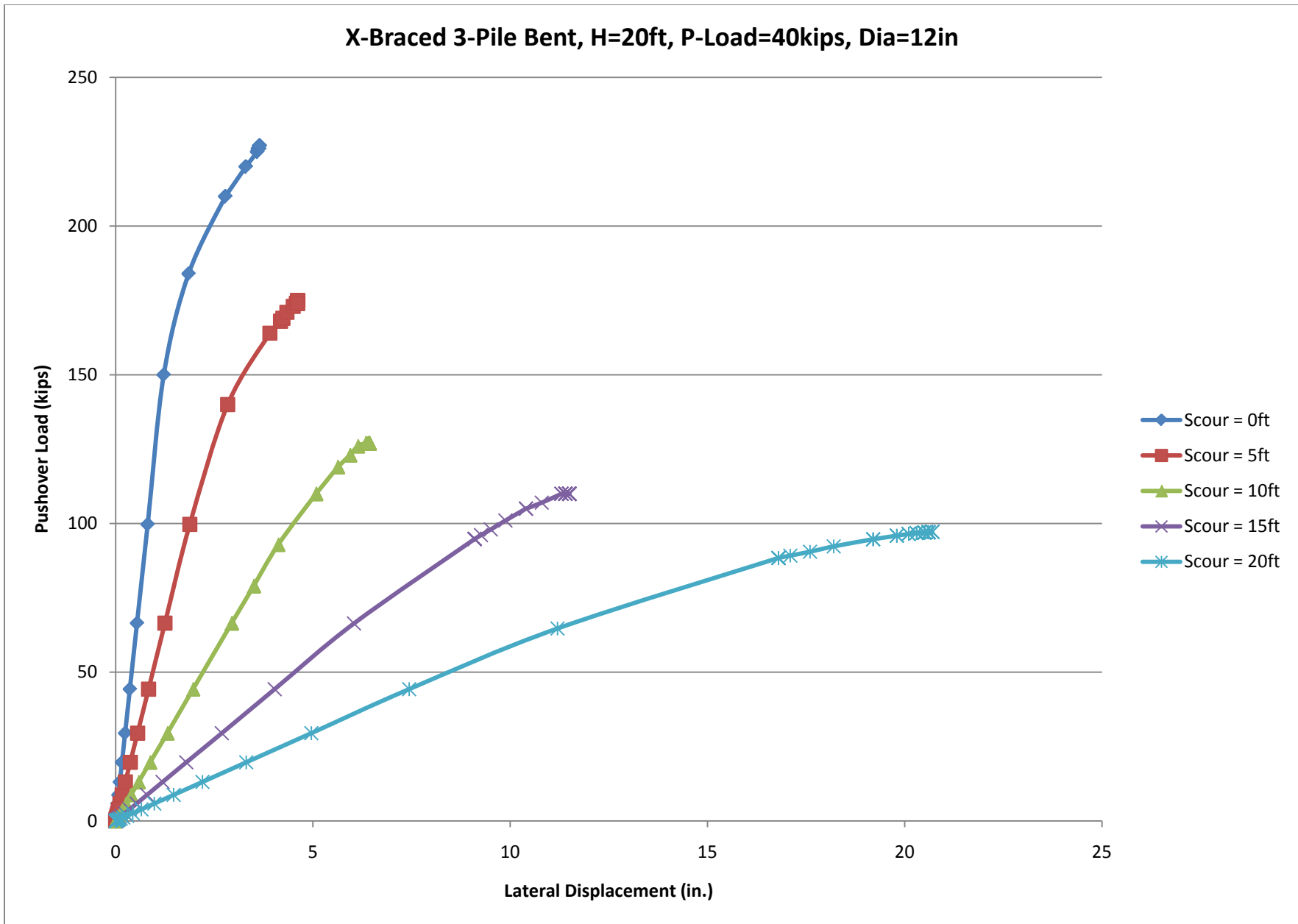


Figure A.22 Pushover Curves for X-Braced 3-Pile Bent, H=20ft, P=20kips, Diameter=12in, Multiple Levels of Scour



**Figure A.23 Pushover Curves for X-Braced 3-Pile Bent, H=20ft, P=40kips, Diameter=12in, Multiple Levels of Scour**

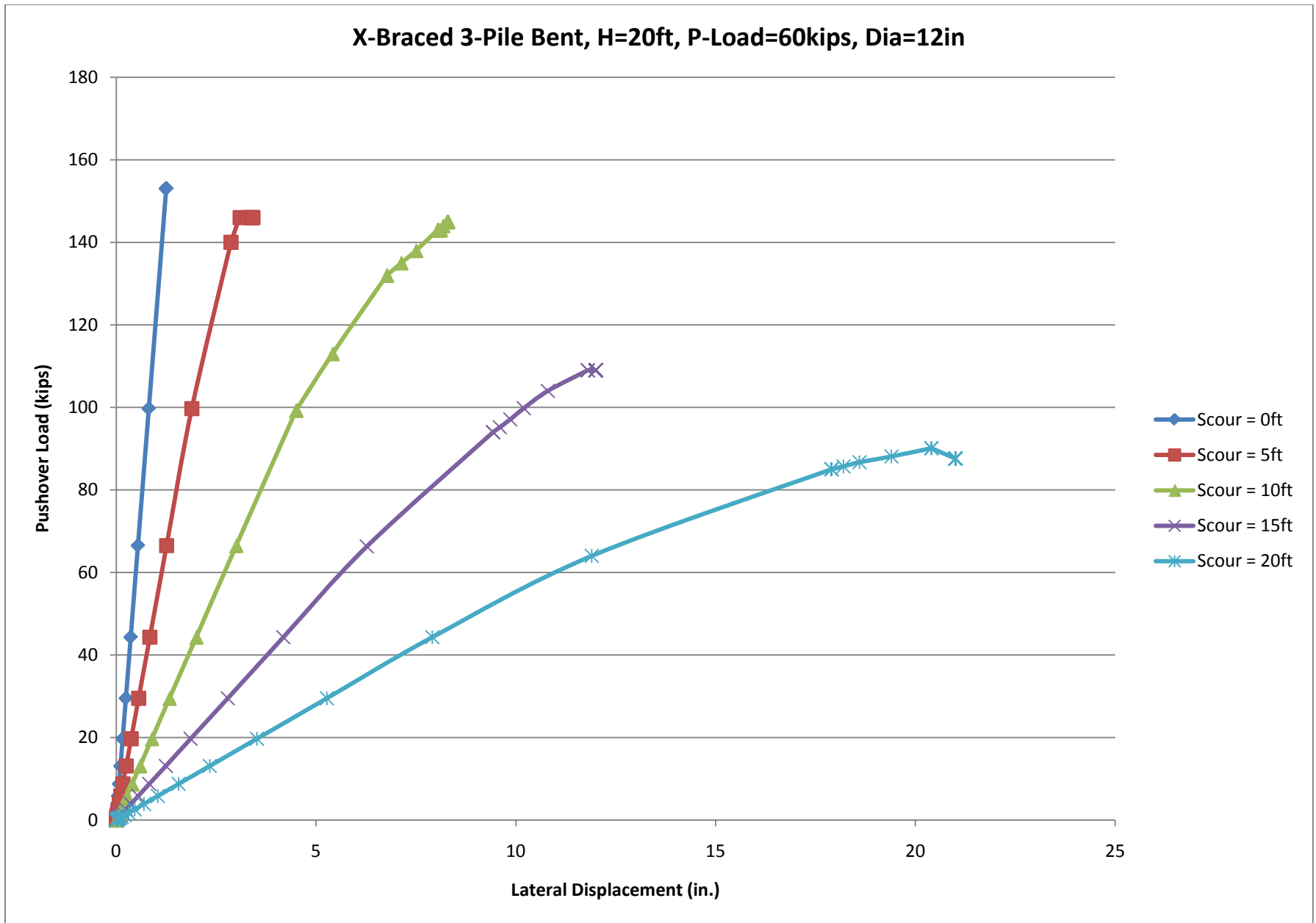


Figure A.24 Pushover Curves for X-Braced 3-Pile Bent, H=20ft, P=60kips, Diameter=12in, Multiple Levels of Scour

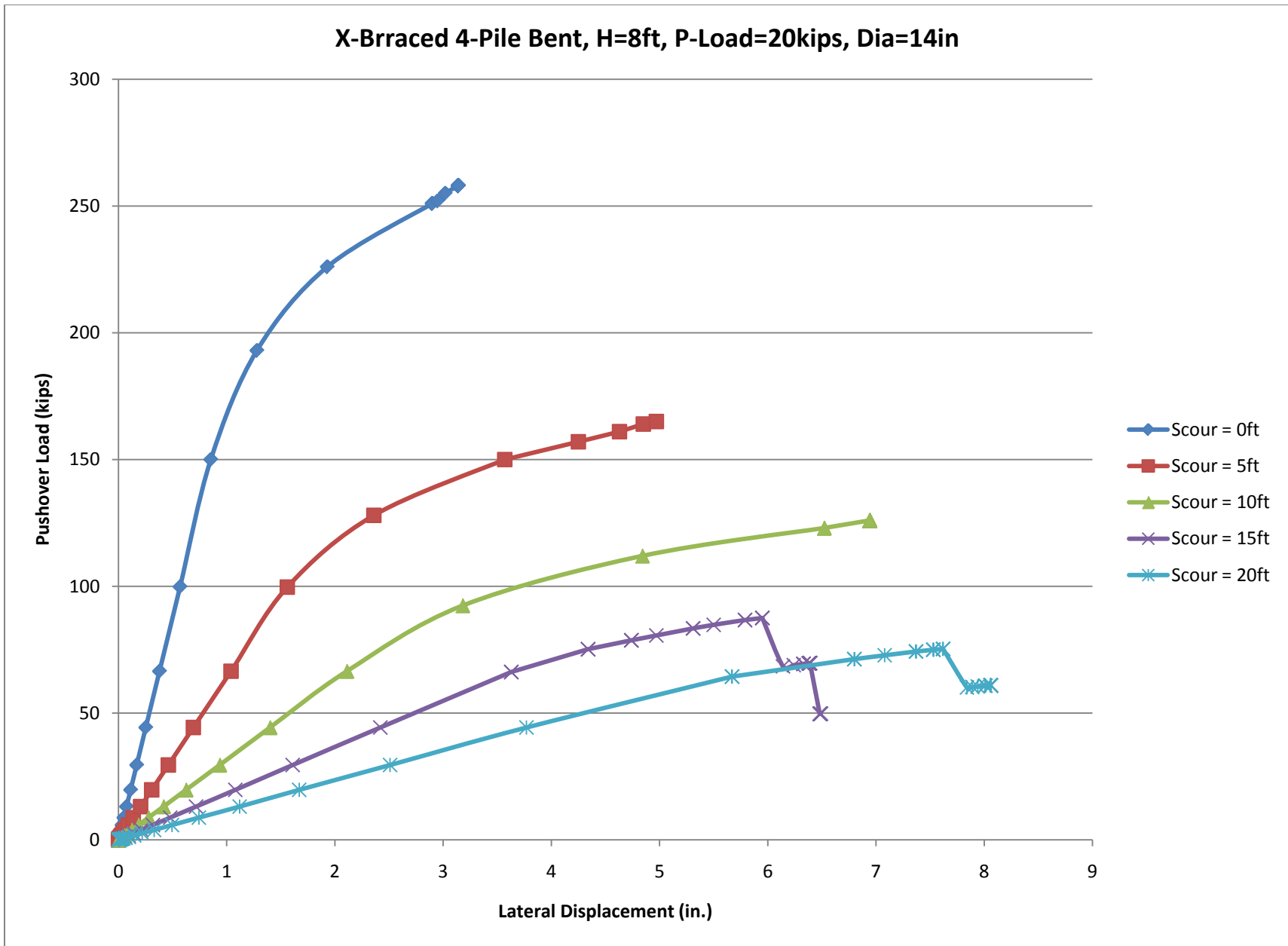


Figure A.25 Pushover Curves for X-Braced 4-Pile Bent, H=8ft, P=20kips, Diameter=14in, Multiple Levels of Scour

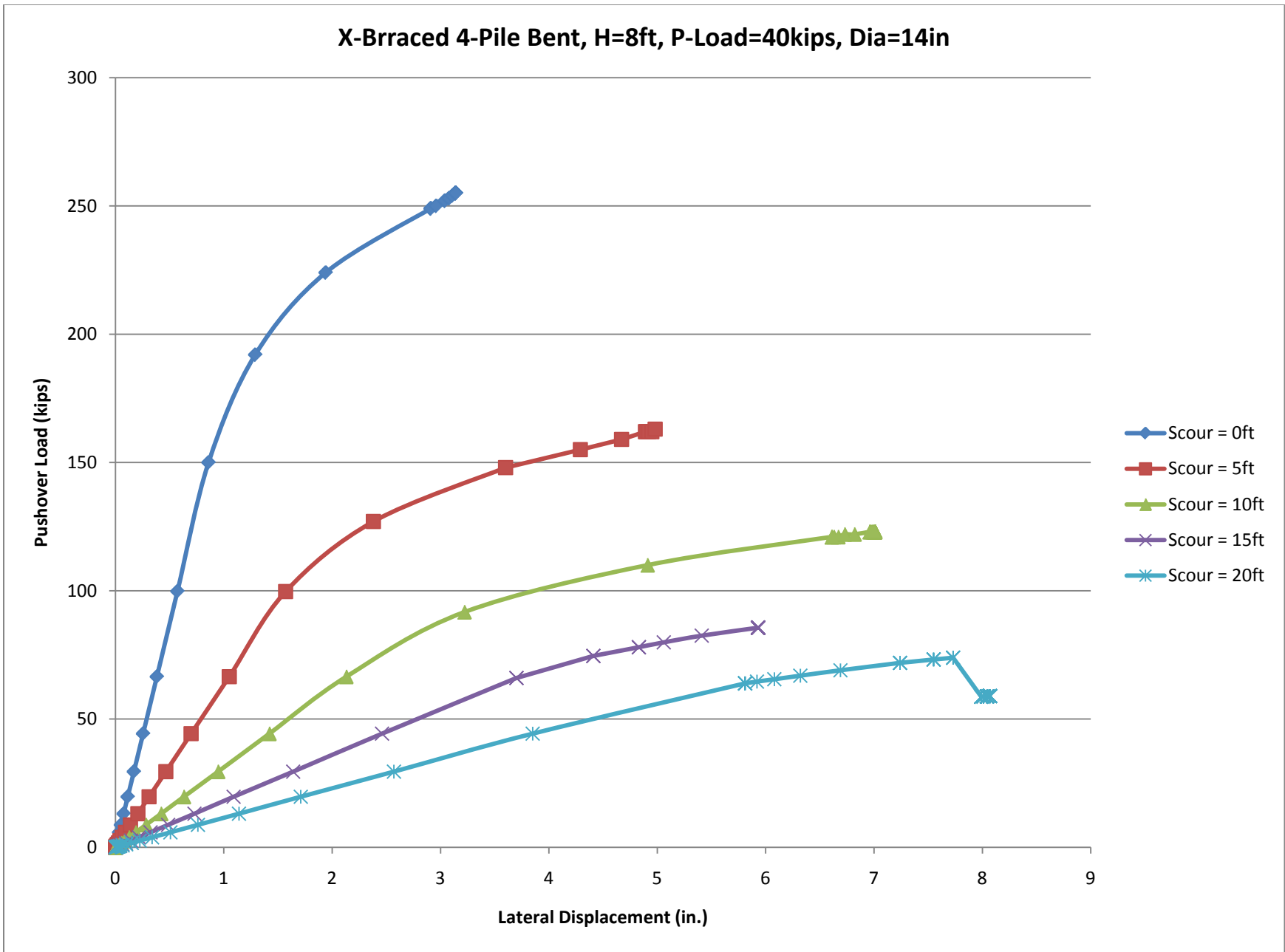
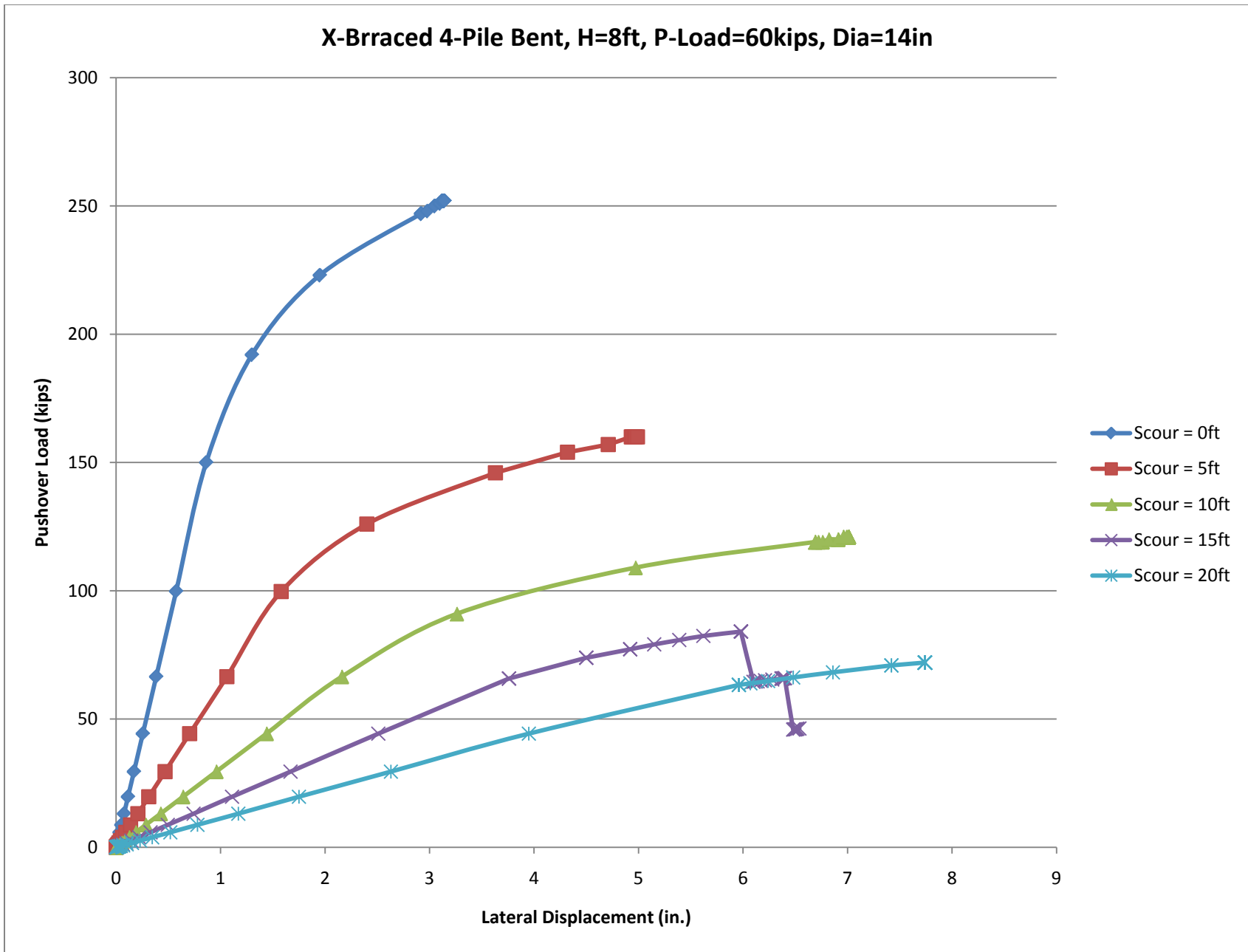


Figure A.26 Pushover Curves for X-Braced 4-Pile Bent, H=8ft, P=40kips, Diameter=14in, Multiple Levels of Scour





**Figure A.27 Pushover Curves for X-Braced 4-Pile Bent, H=8ft, P=60kips, Diameter=14in, Multiple Levels of Scour**

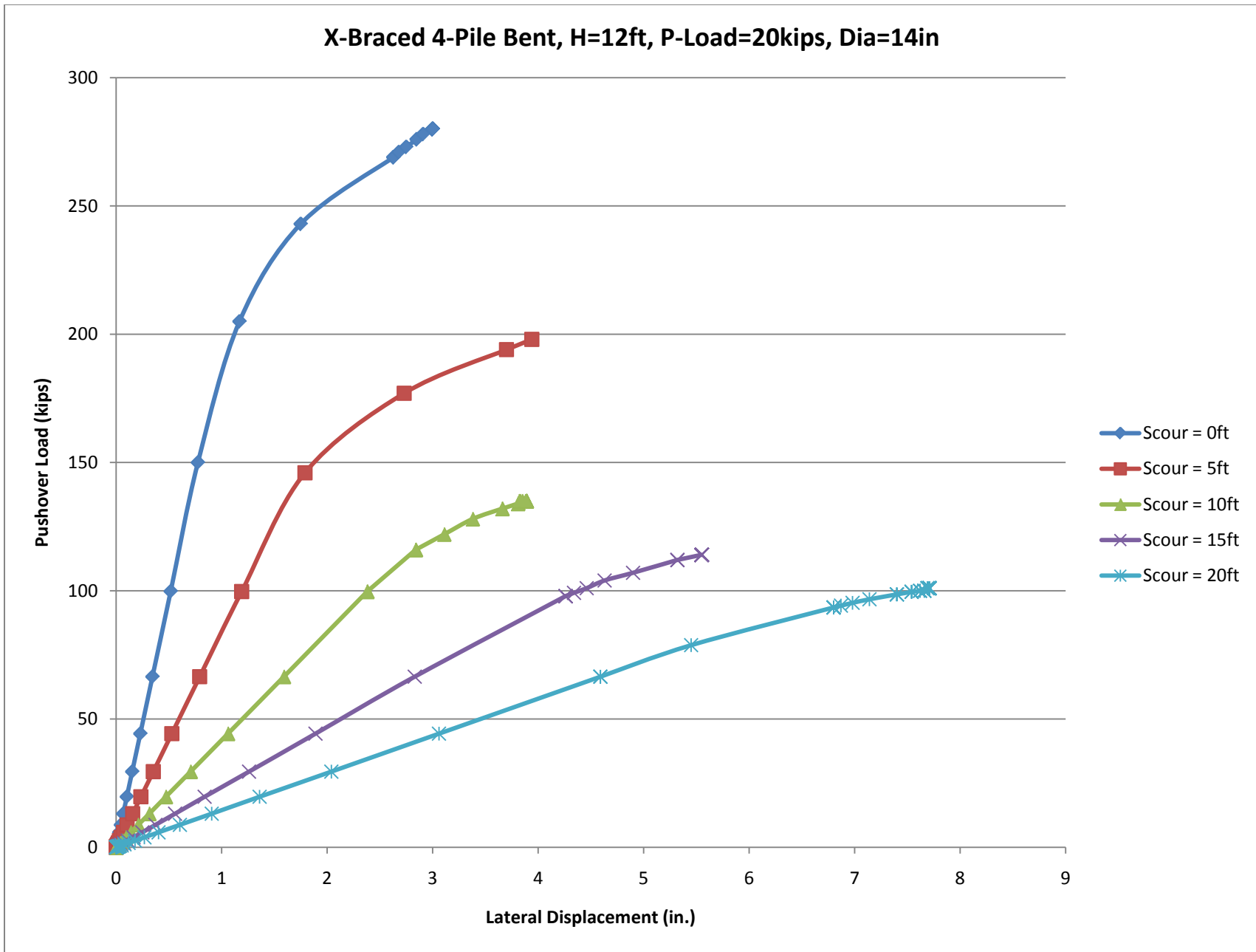


Figure A.28 Pushover Curves for X-Braced 4-Pile Bent, H=12ft, P=20kips, Diameter=14in, Multiple Levels of Scour

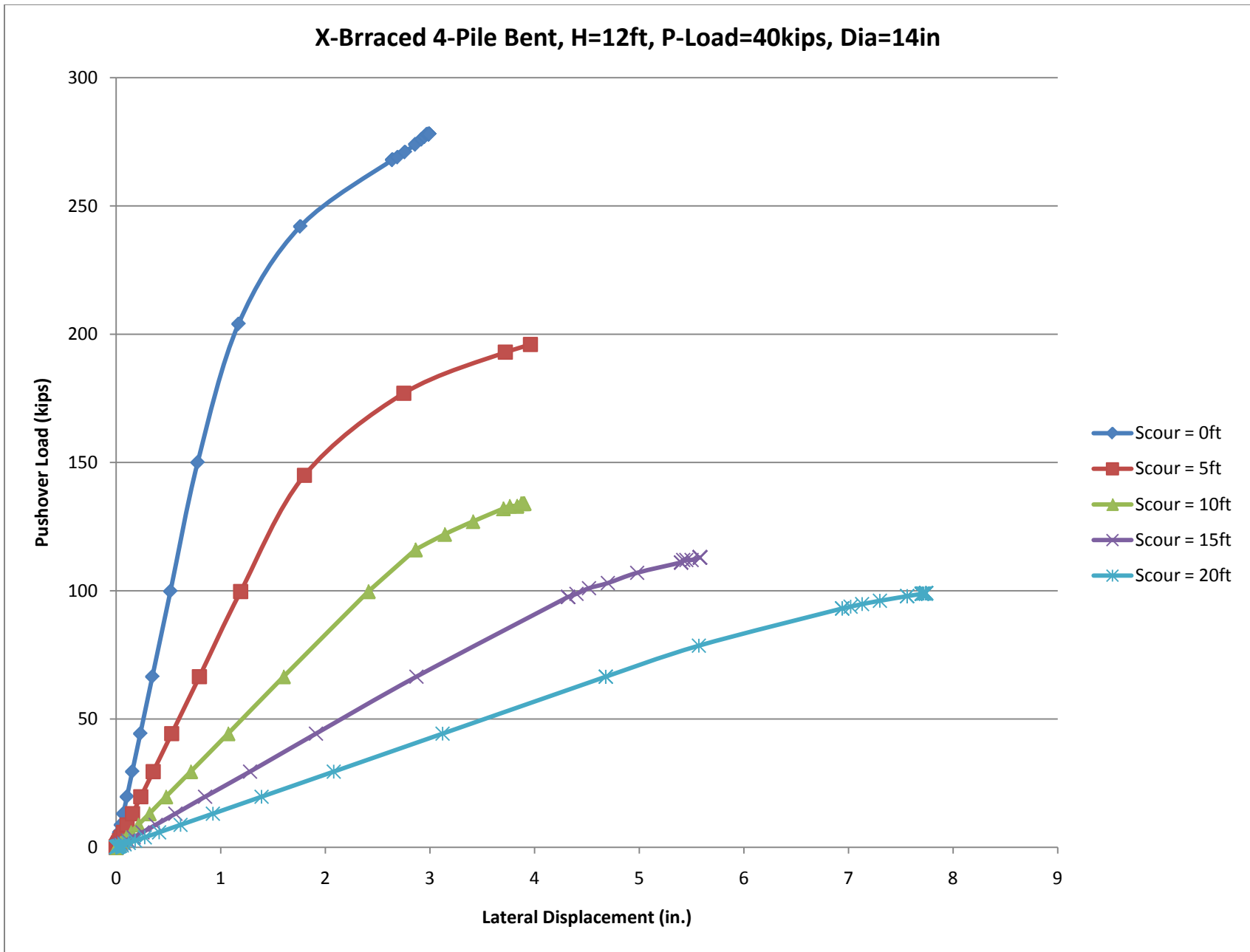


Figure A.29 Pushover Curves for X-Braced 4-Pile Bent, H=12ft, P=40kips, Diameter=14in, Multiple Levels of Scour

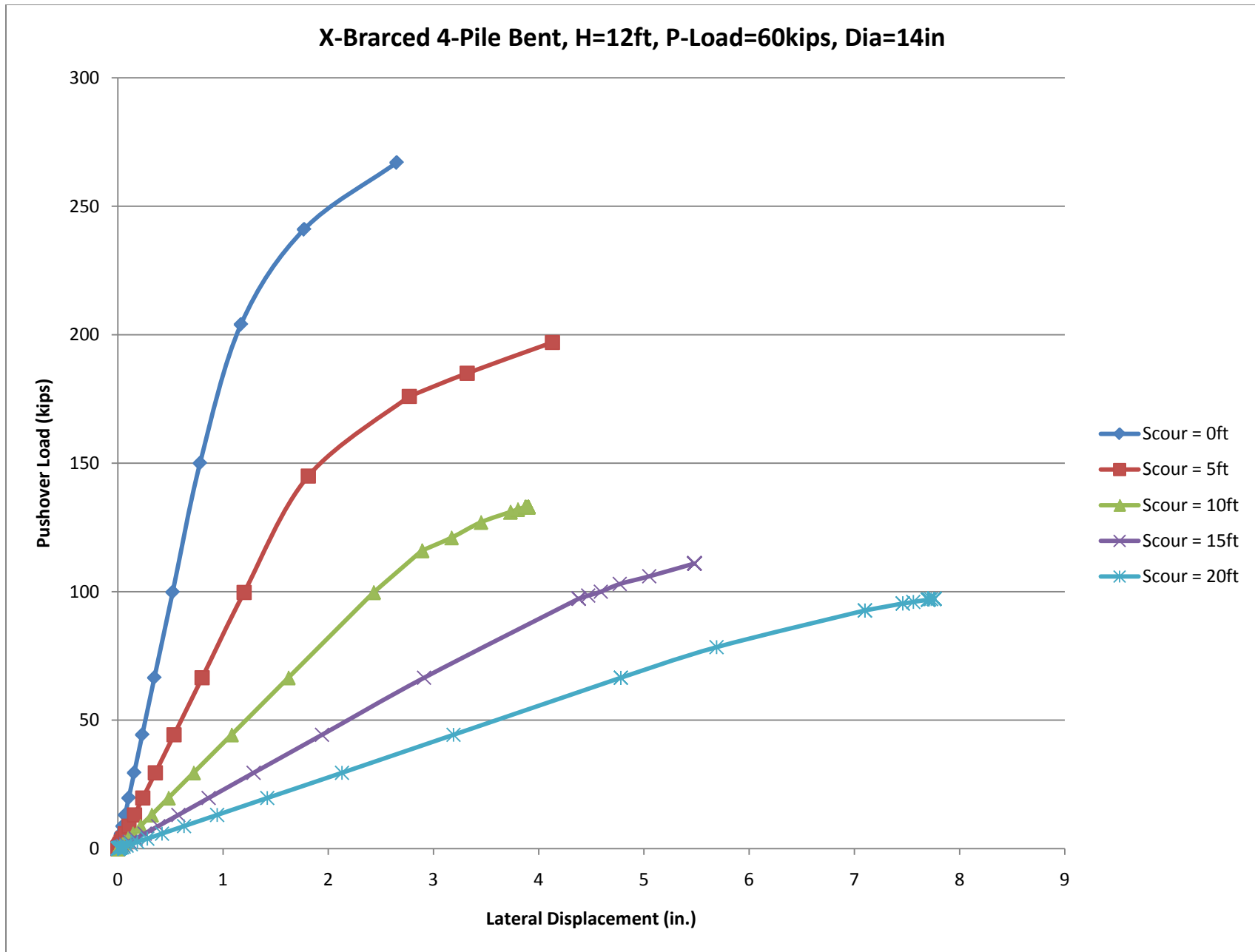


Figure A.30 Pushover Curves for X-Braced 4-Pile Bent, H=12ft, P=60kips, Diameter=14in, Multiple Levels of Scour

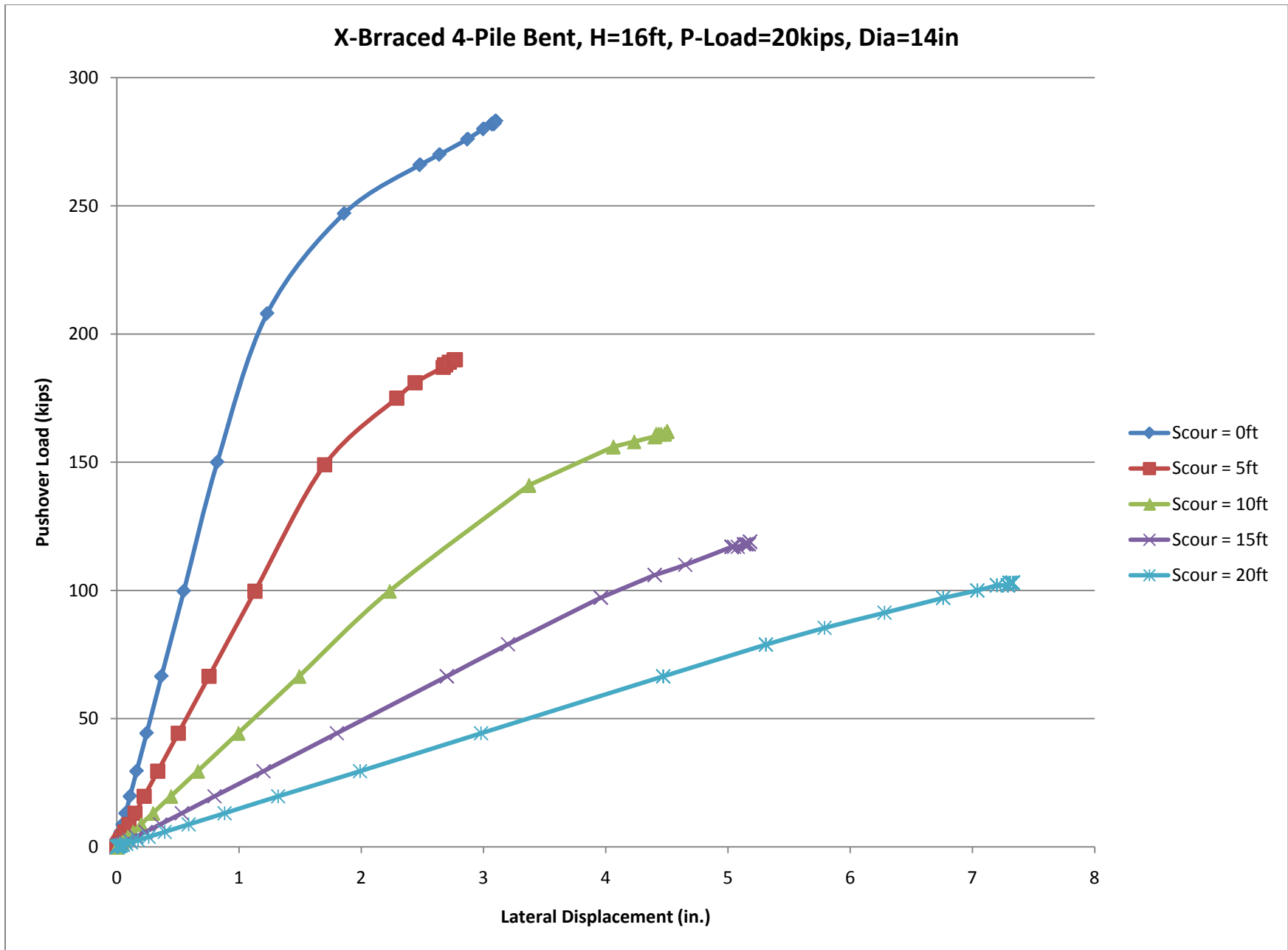


Figure A.31 Pushover Curves for X-Braced 4-Pile Bent, H=16ft, P=20kips, Diameter=14in, Multiple Levels of Scour

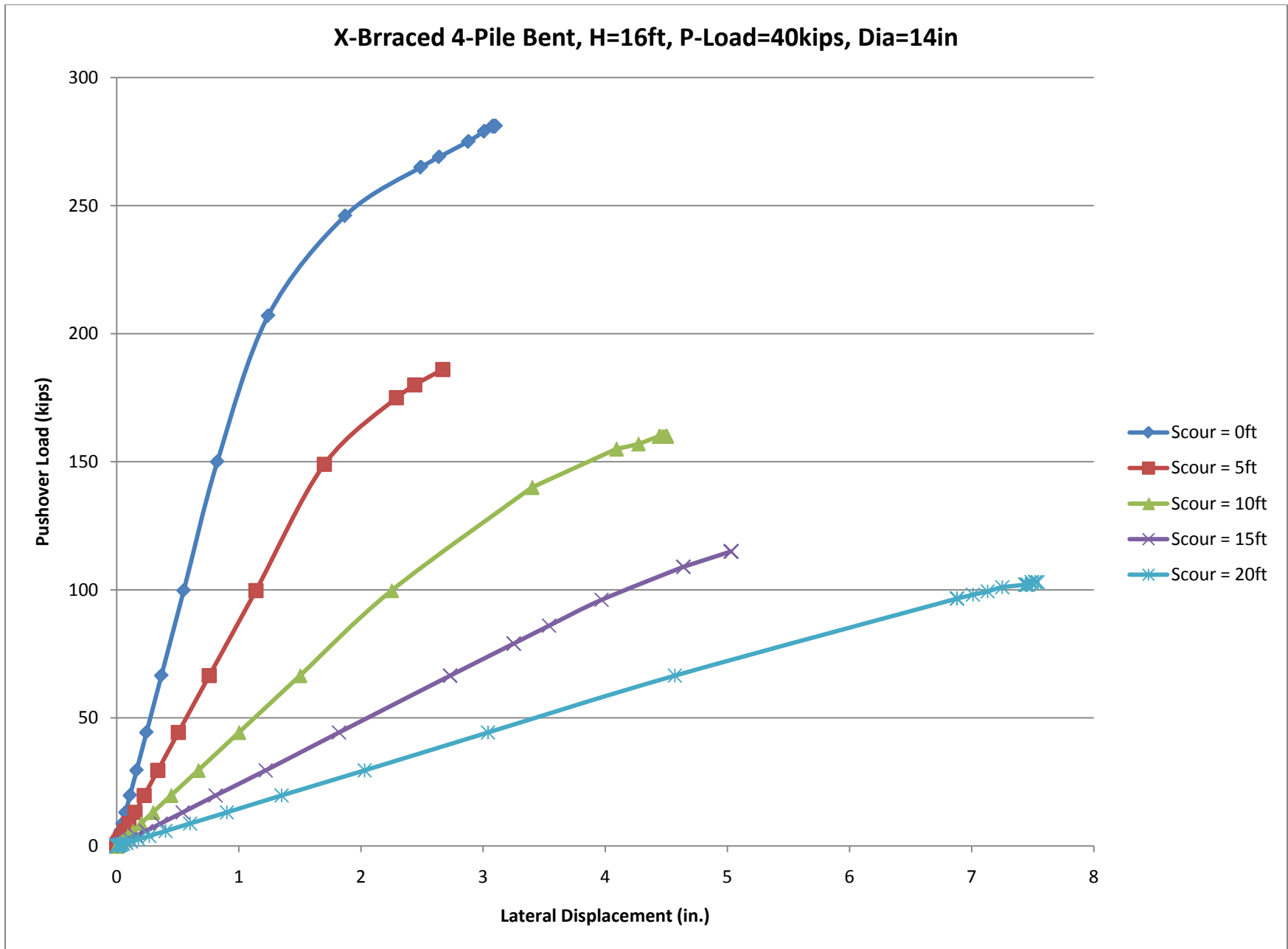


Figure A.32 Pushover Curves for X-Braced 4-Pile Bent, H=16ft, P=40kips, Diameter=14in, Multiple Levels of Scour

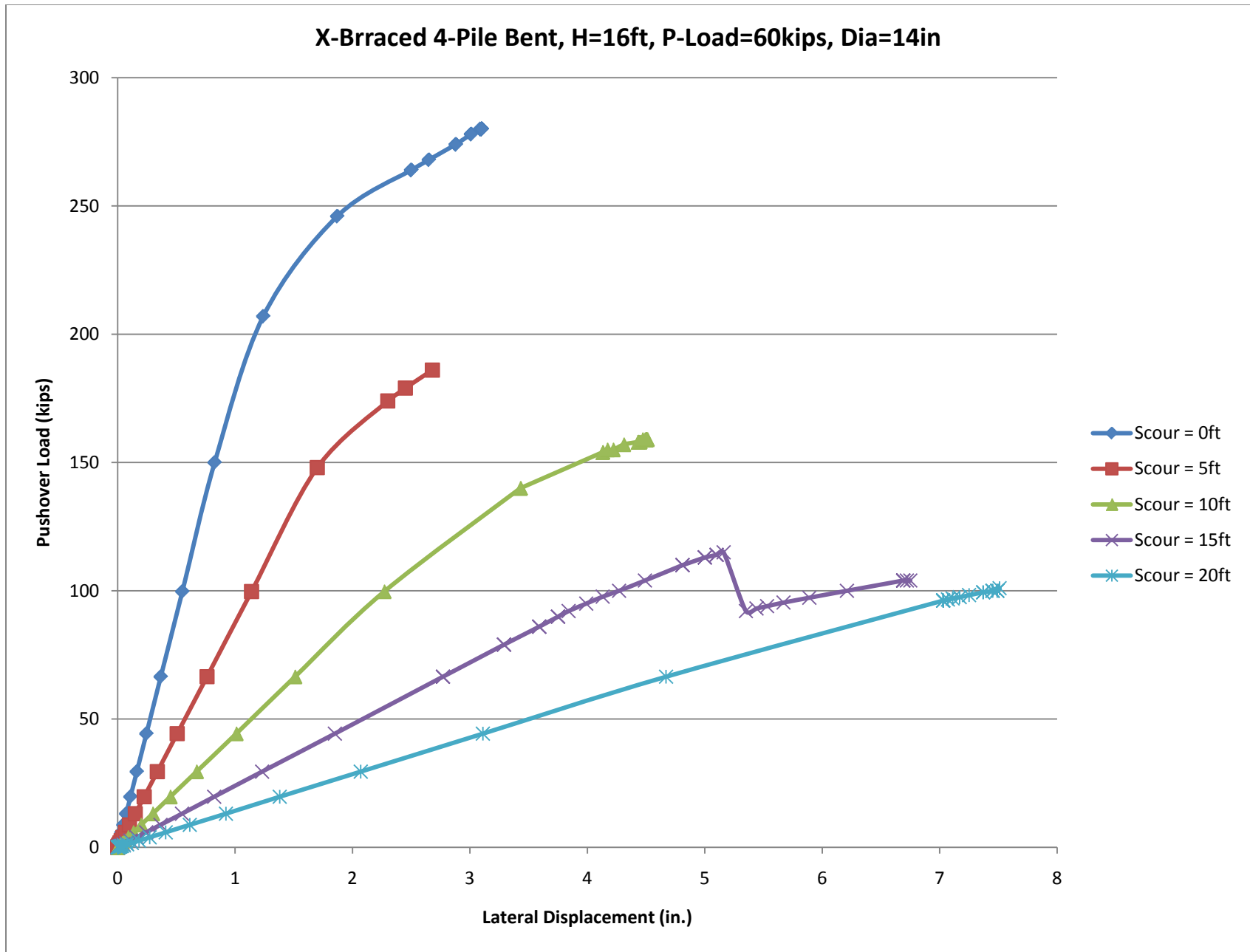
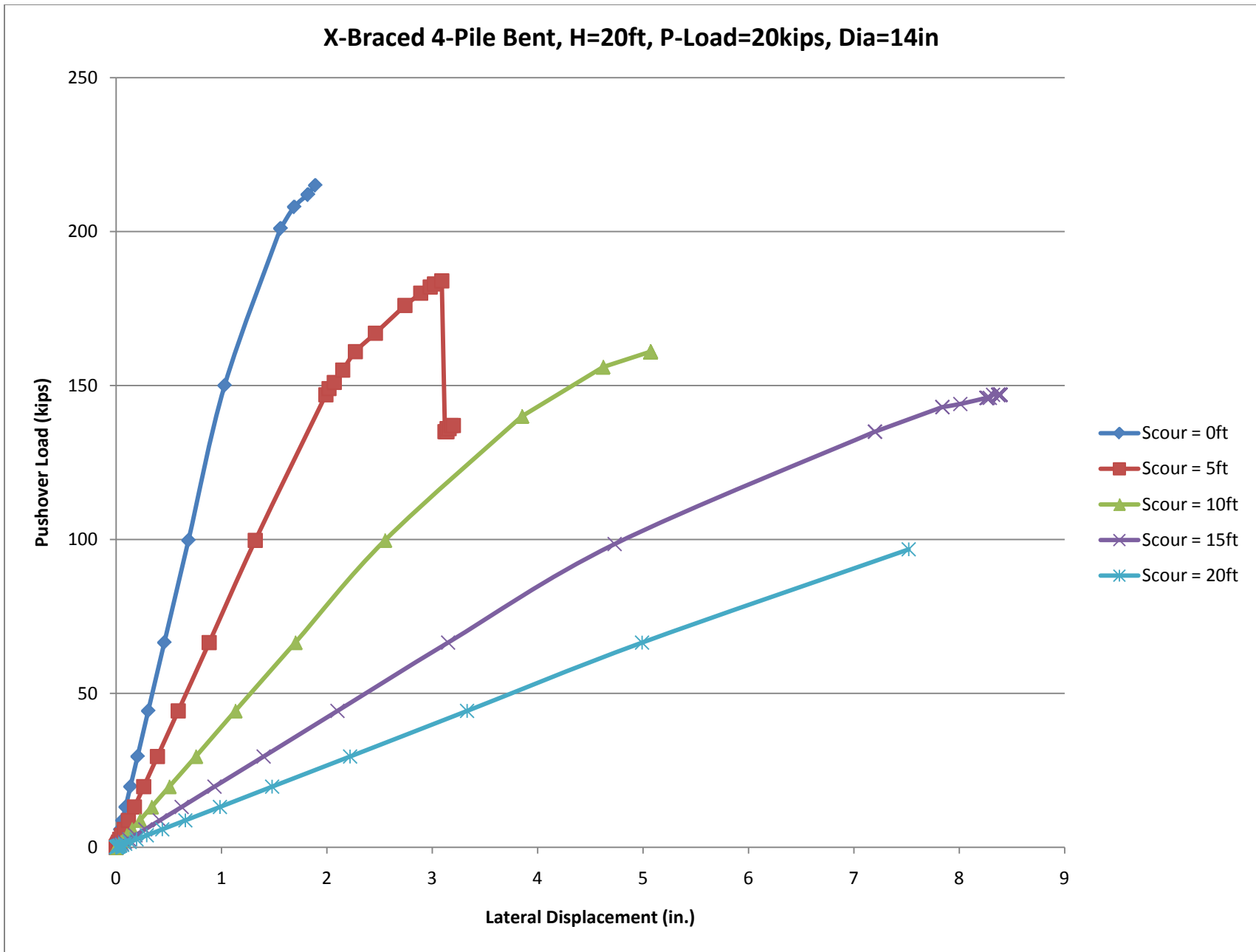


Figure A.33 Pushover Curves for X-Braced 4-Pile Bent, H=20ft, P=60kips, Diameter=14in, Multiple Levels of Scour



**Figure A.34 Pushover Curves for X-Braced 4-Pile Bent, H=20ft, P=20kips, Diameter=14in, Multiple Levels of Scour**



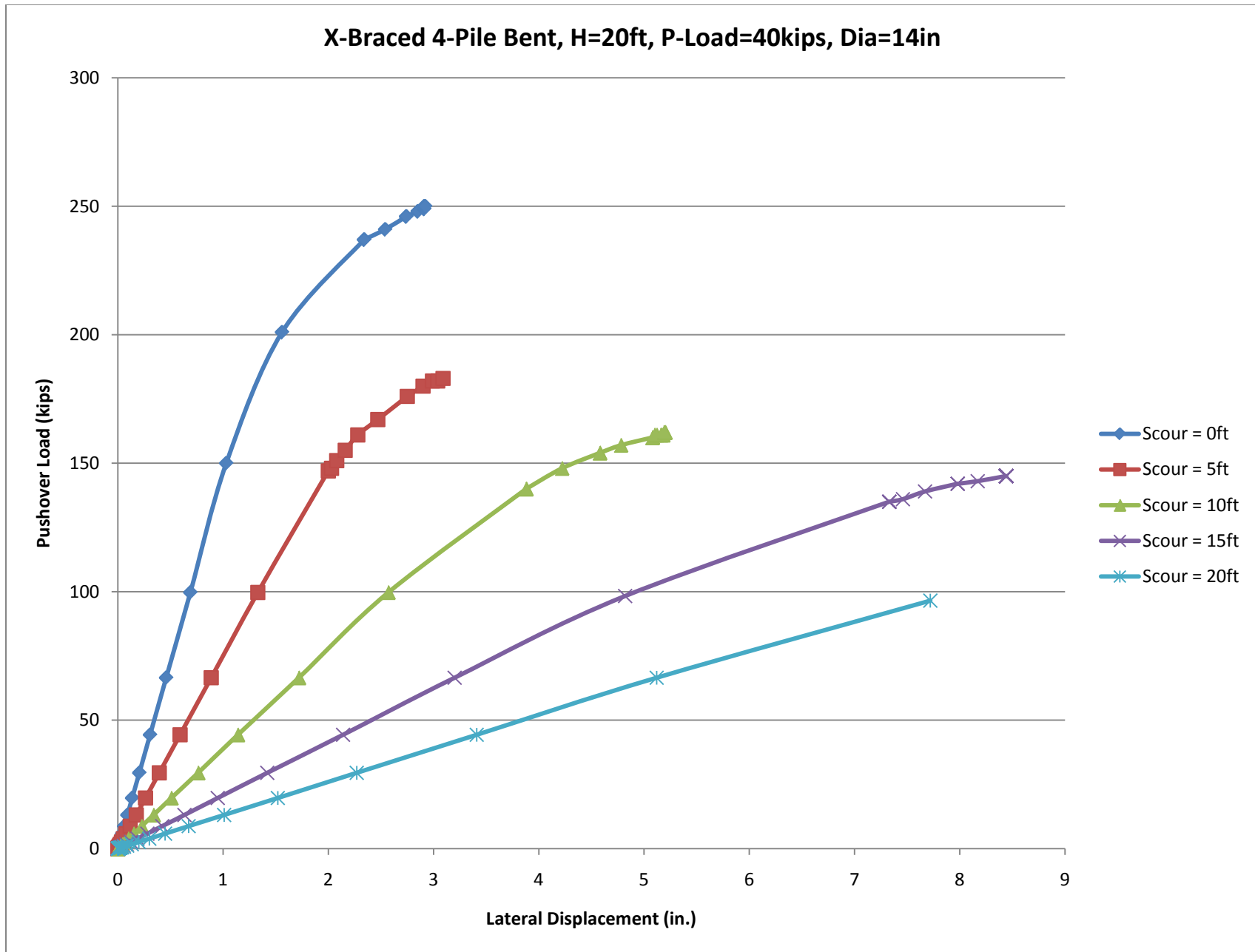
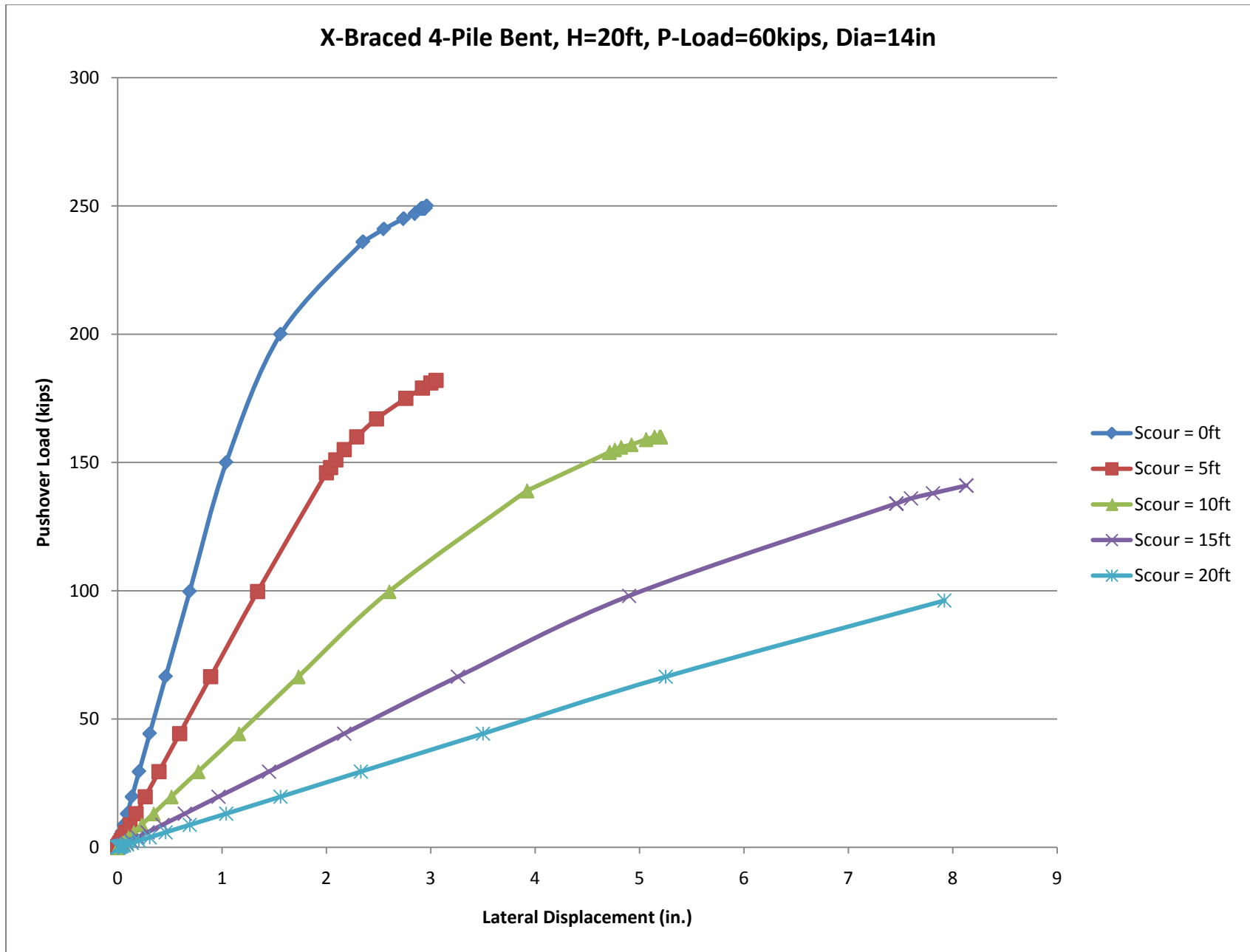


Figure A.35 Pushover Curves for X-Braced 4-Pile Bent, H=20ft, P=40kips, Diameter=14in, Multiple Levels of Scour



**Figure A.36 Pushover Curves for X-Braced 4-Pile Bent, H=20ft, P=60kips, Diameter=14in, Multiple Levels of Scour**

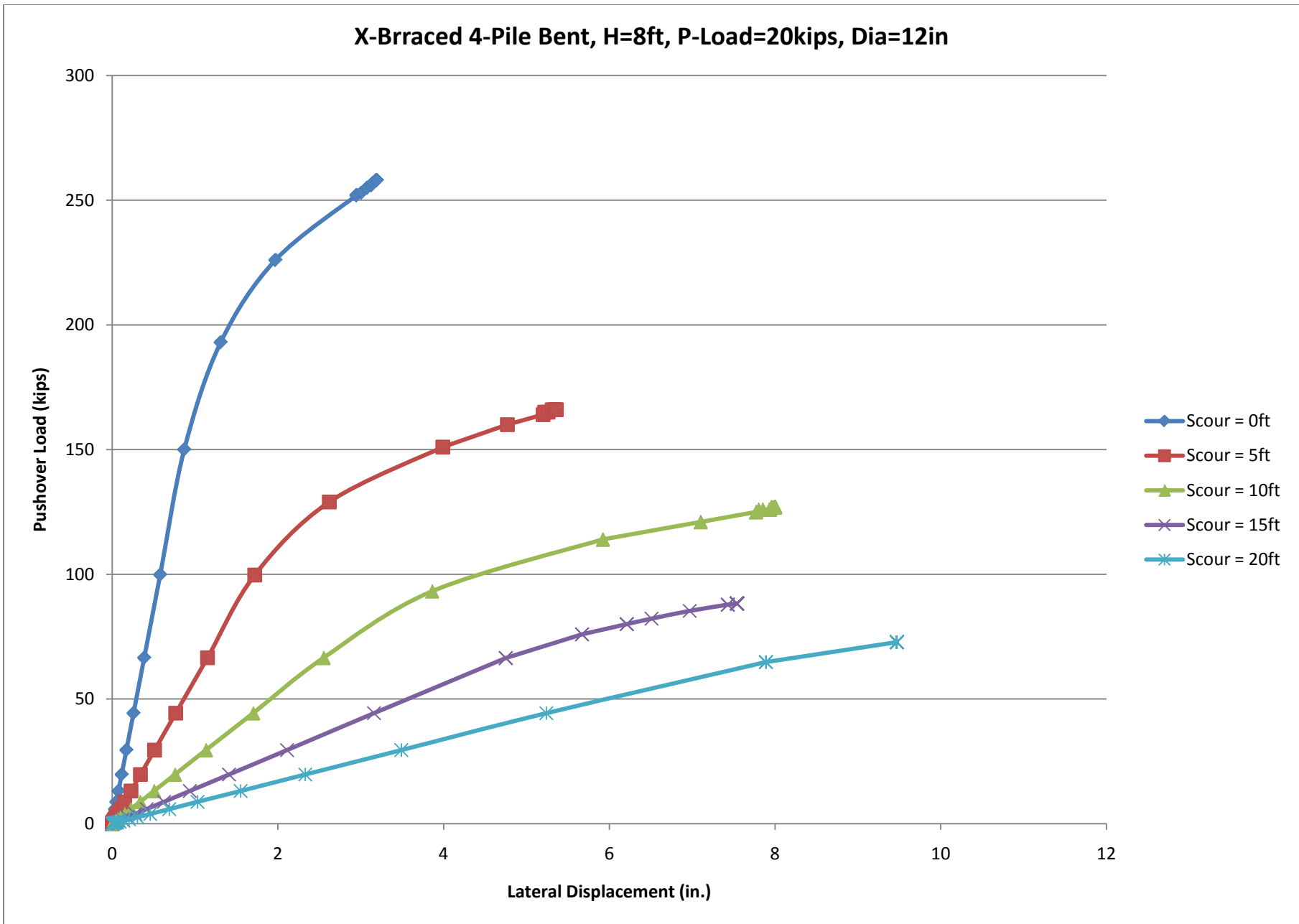


Figure A.37 Pushover Curves for X-Braced 4-Pile Bent, H=8ft, P=20kips, Diameter=12in, Multiple Levels of Scour

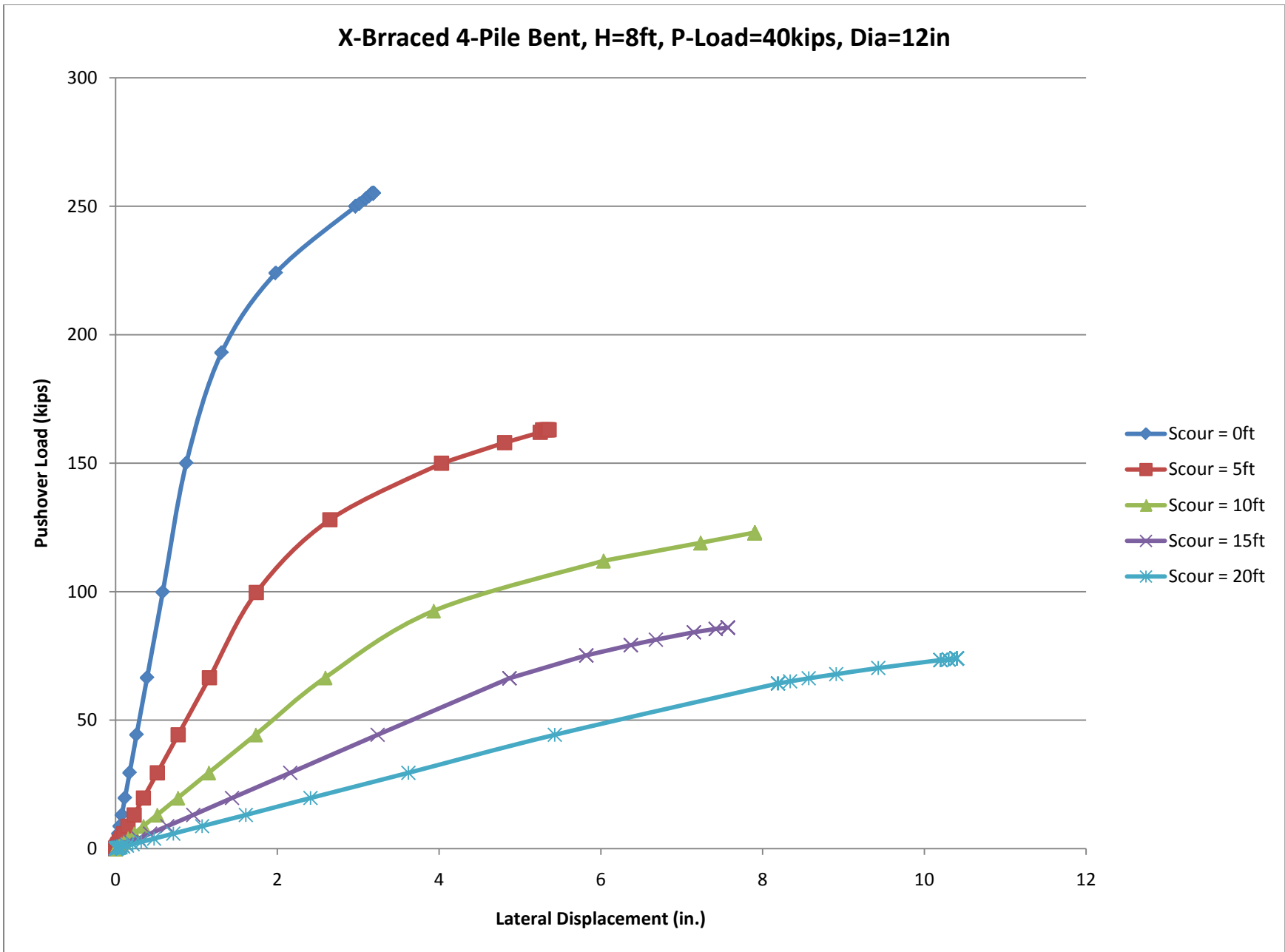
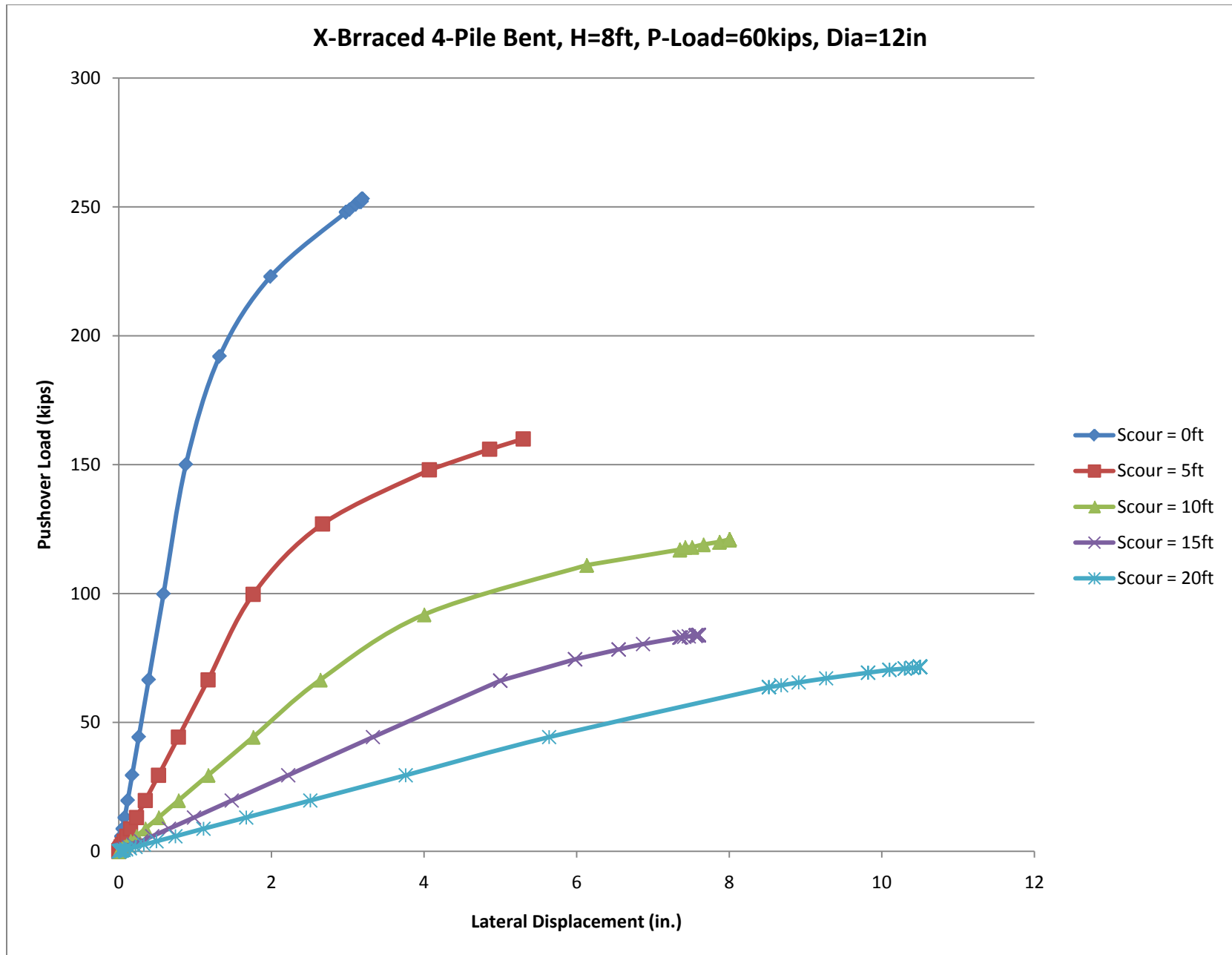


Figure A.38 Pushover Curves for X-Braced 4-Pile Bent, H=8ft, P=40kips, Diameter=12in, Multiple Levels of Scour



**Figure A.39 Pushover Curves for X-Braced 4-Pile Bent, H=8ft, P=60kips, Diameter=12in, Multiple Levels of Scour**

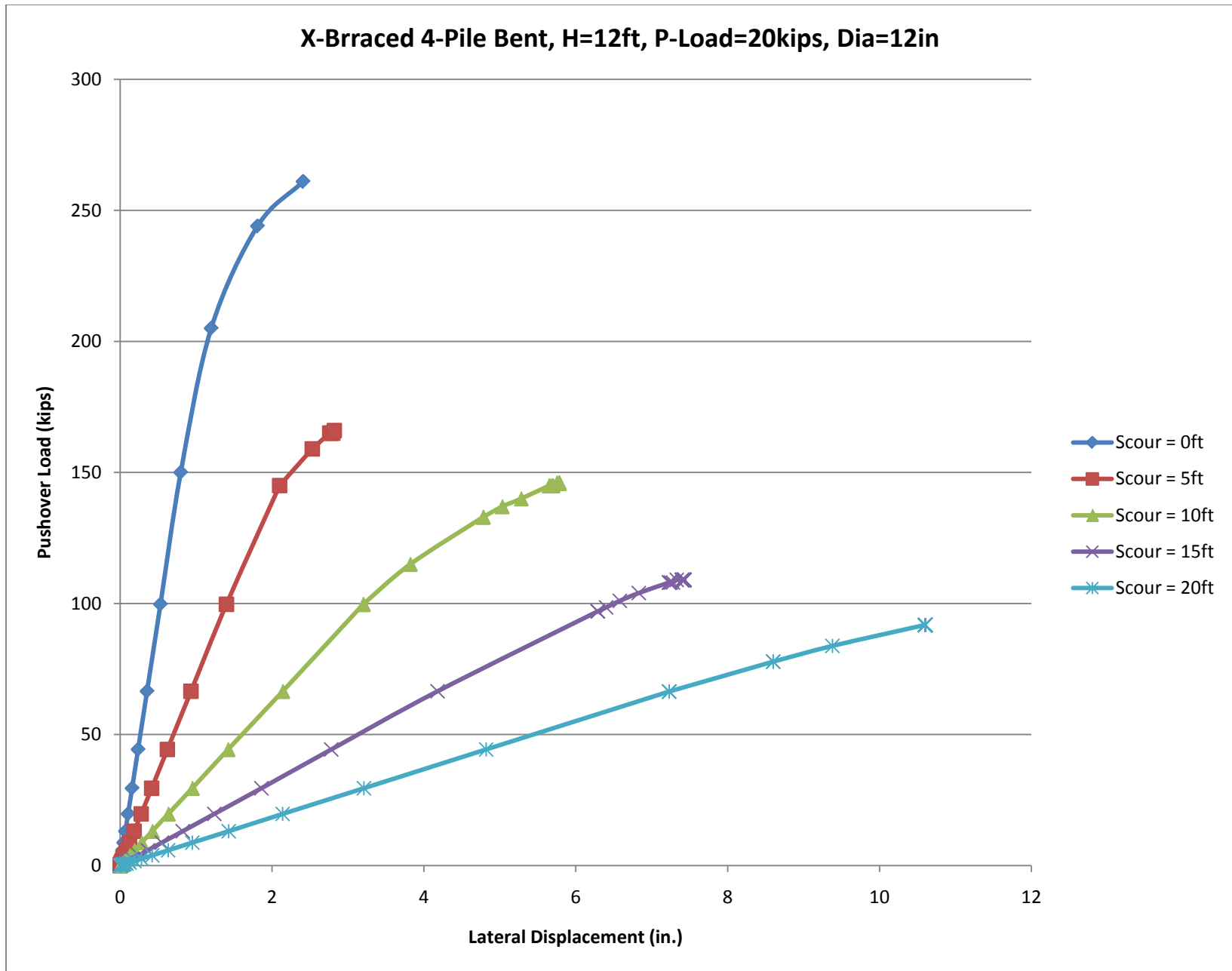


Figure A.40 Pushover Curves for X-Braced 4-Pile Bent, H=12ft, P=20kips, Diameter=12in, Multiple Levels of Scour

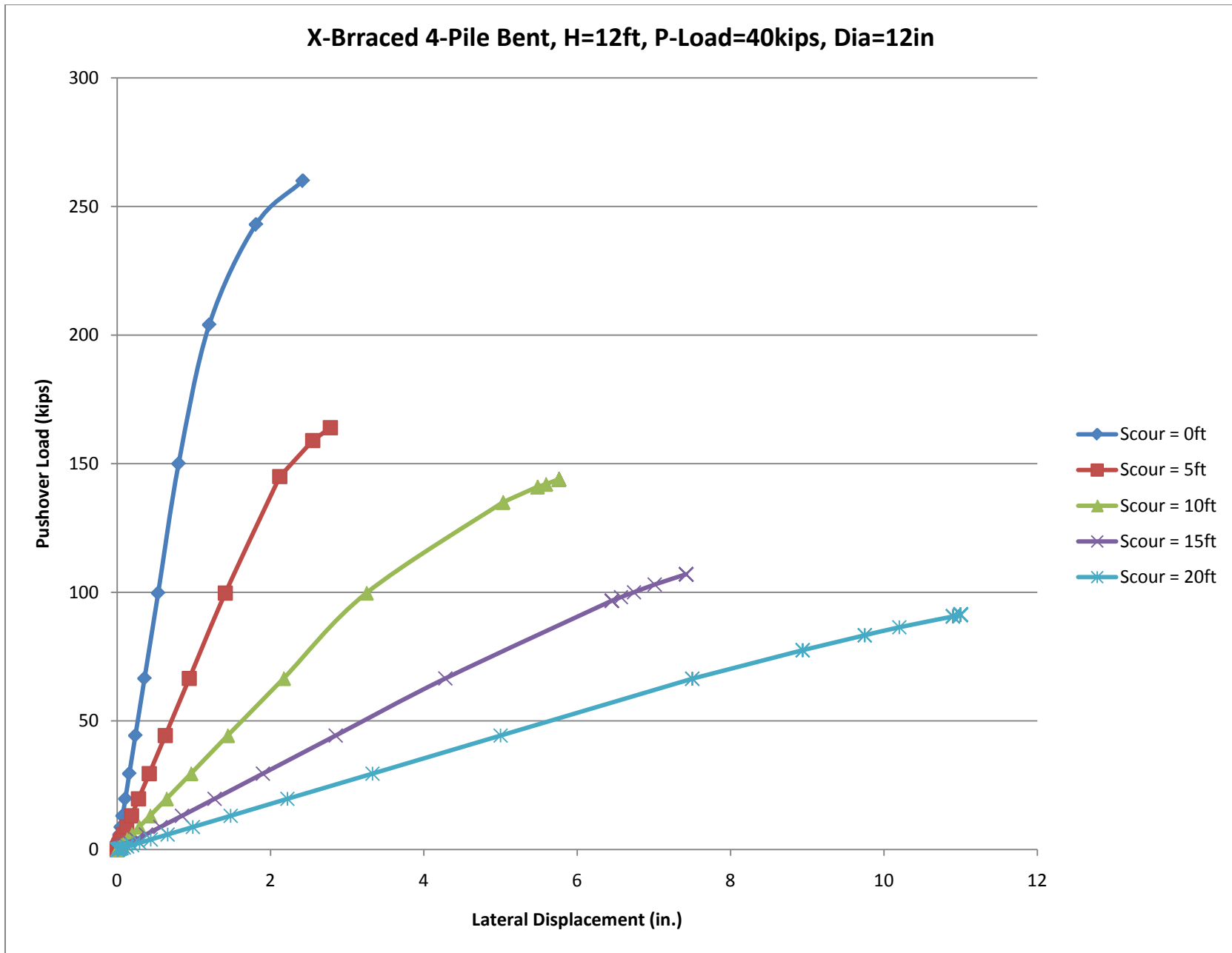


Figure A.41 Pushover Curves for X-Braced 4-Pile Bent, H=12ft, P=40kips, Diameter=12in, Multiple Levels of Scour

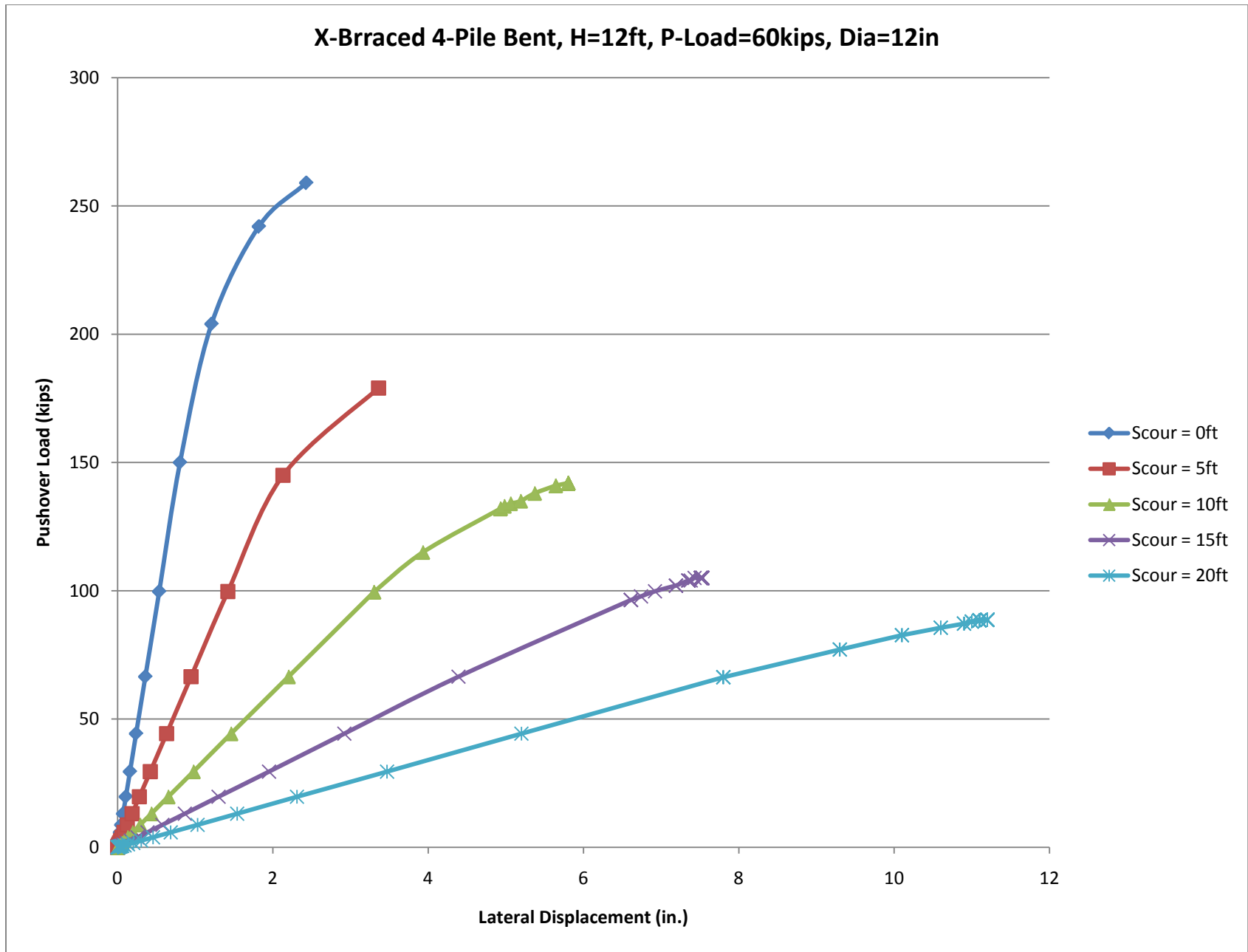
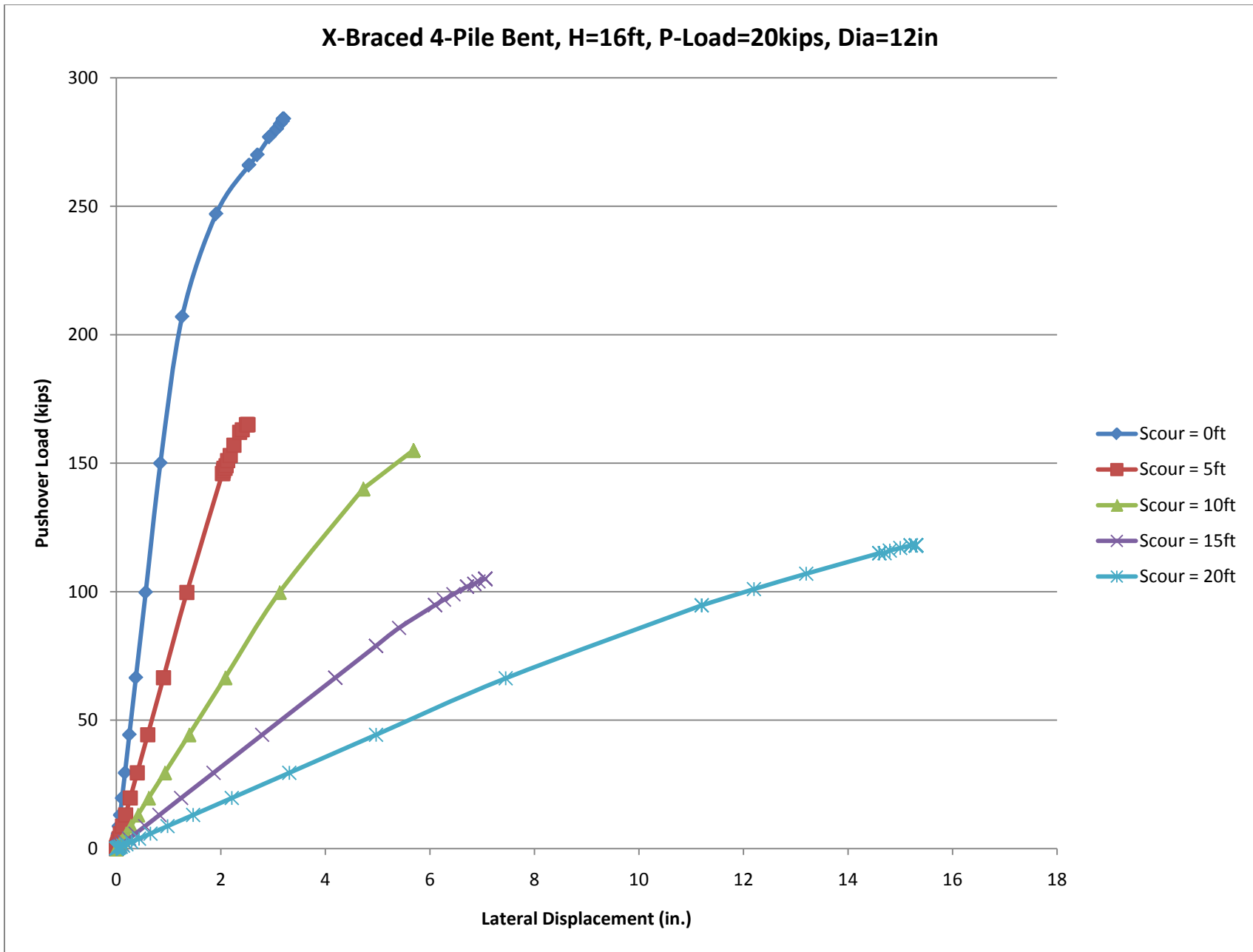
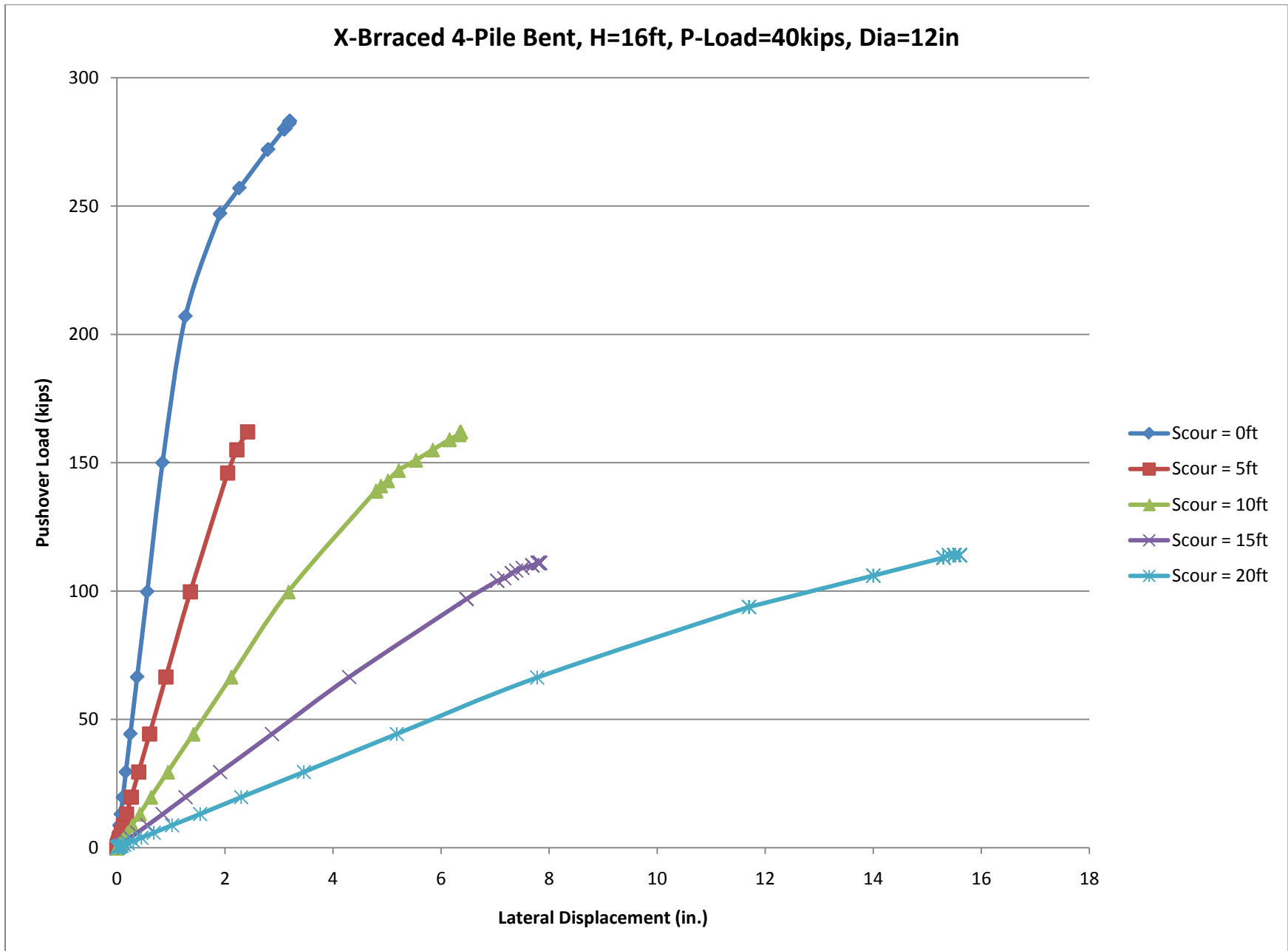


Figure A.42 Pushover Curves for X-Braced 4-Pile Bent, H=12ft, P=60kips, Diameter=12in, Multiple Levels of Scour

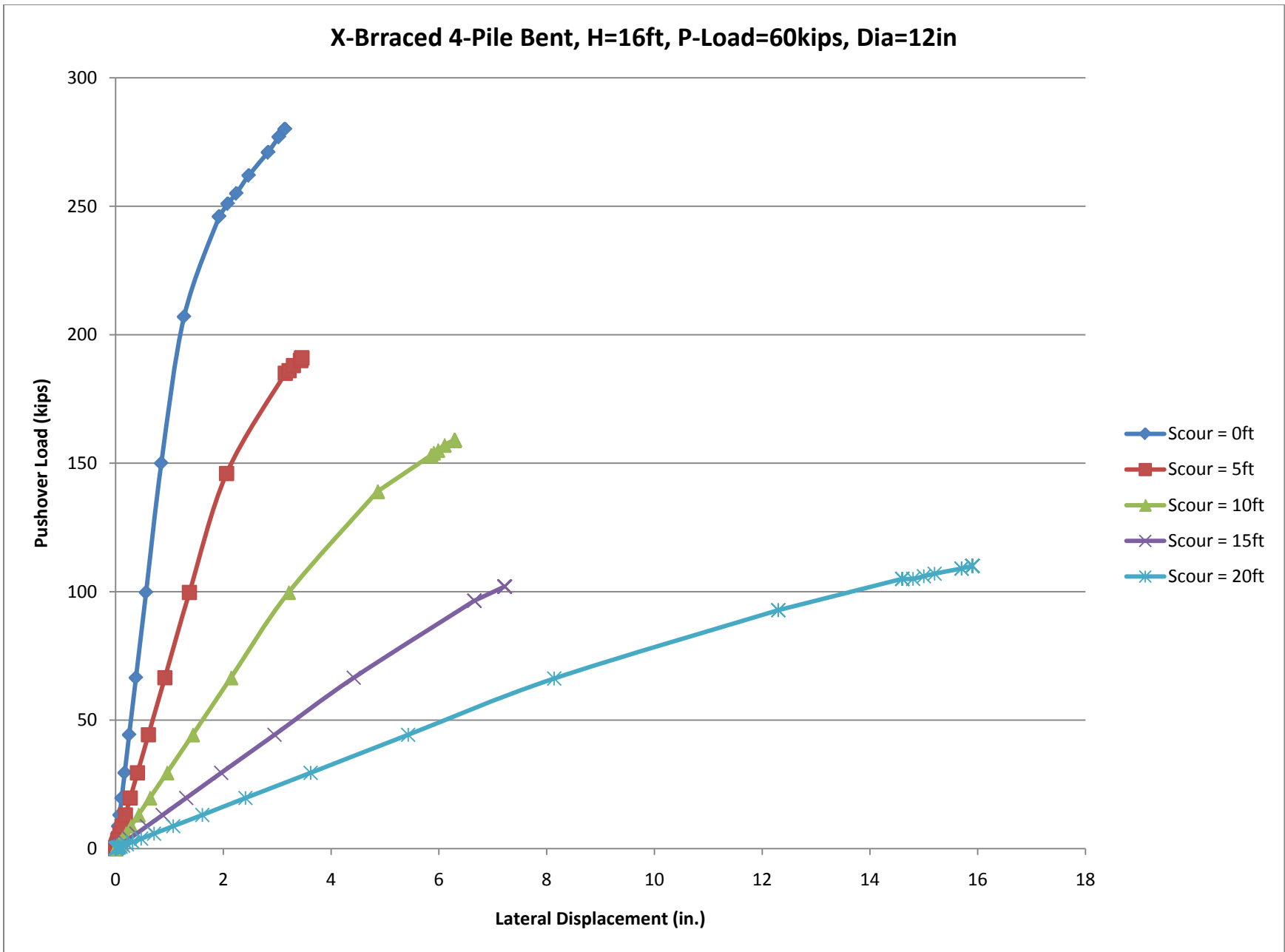




**Figure A.43 Pushover Curves for X-Braced 4-Pile Bent, H=16ft, P=20kips, Diameter=12in, Multiple Levels of Scour**



**Figure A.44 Pushover Curves for X-Braced 4-Pile Bent, H=16ft, P=40kips, Diameter=12in, Multiple Levels of Scour**



**Figure A.45 Pushover Curves for X-Braced 4-Pile Bent, H=20ft, P=60kips, Diameter=12in, Multiple Levels of Scour**

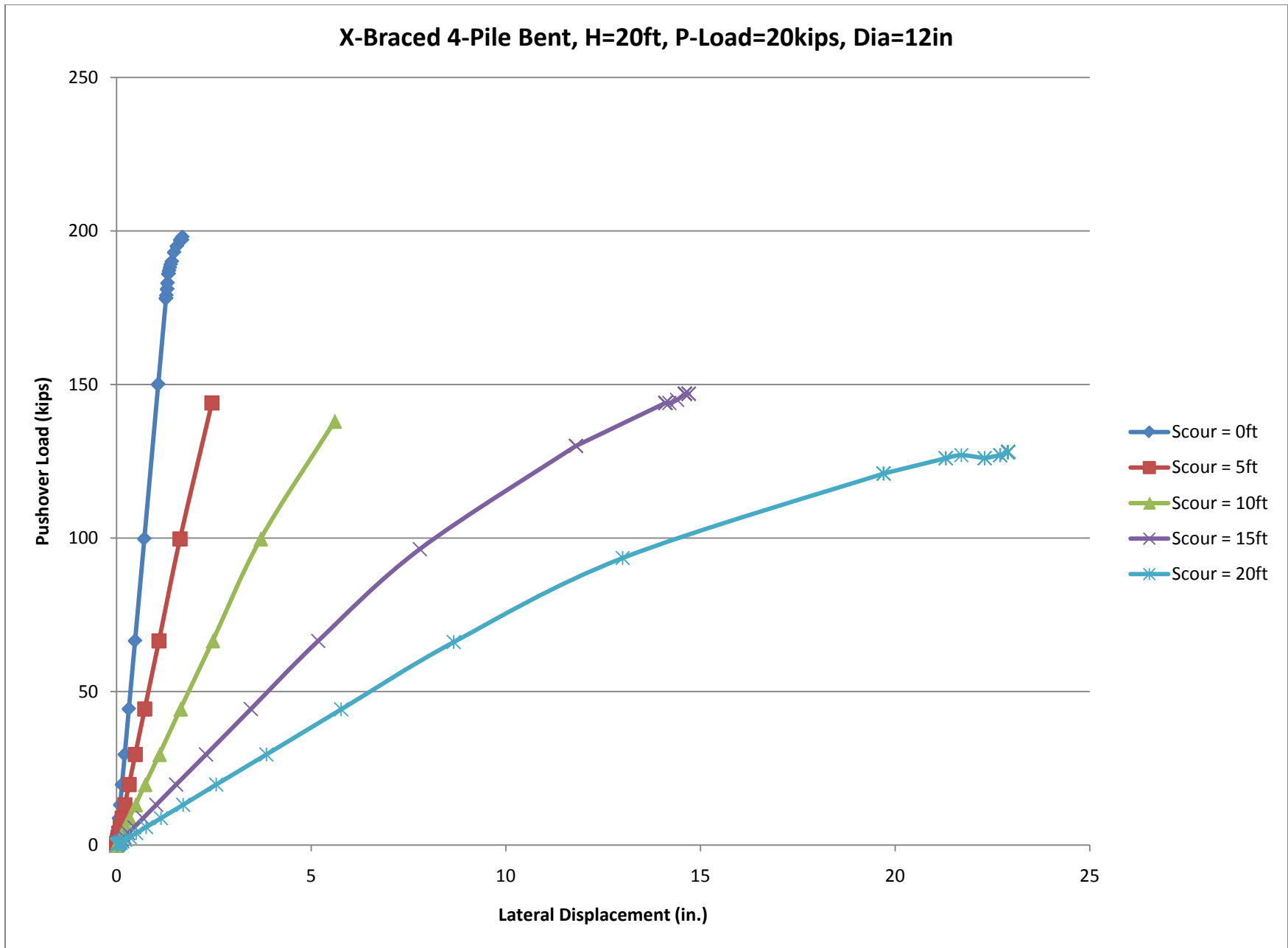


Figure A.46 Pushover Curves for X-Braced 4-Pile Bent, H=20ft, P=20kips, Diameter=12in, Multiple Levels of Scour

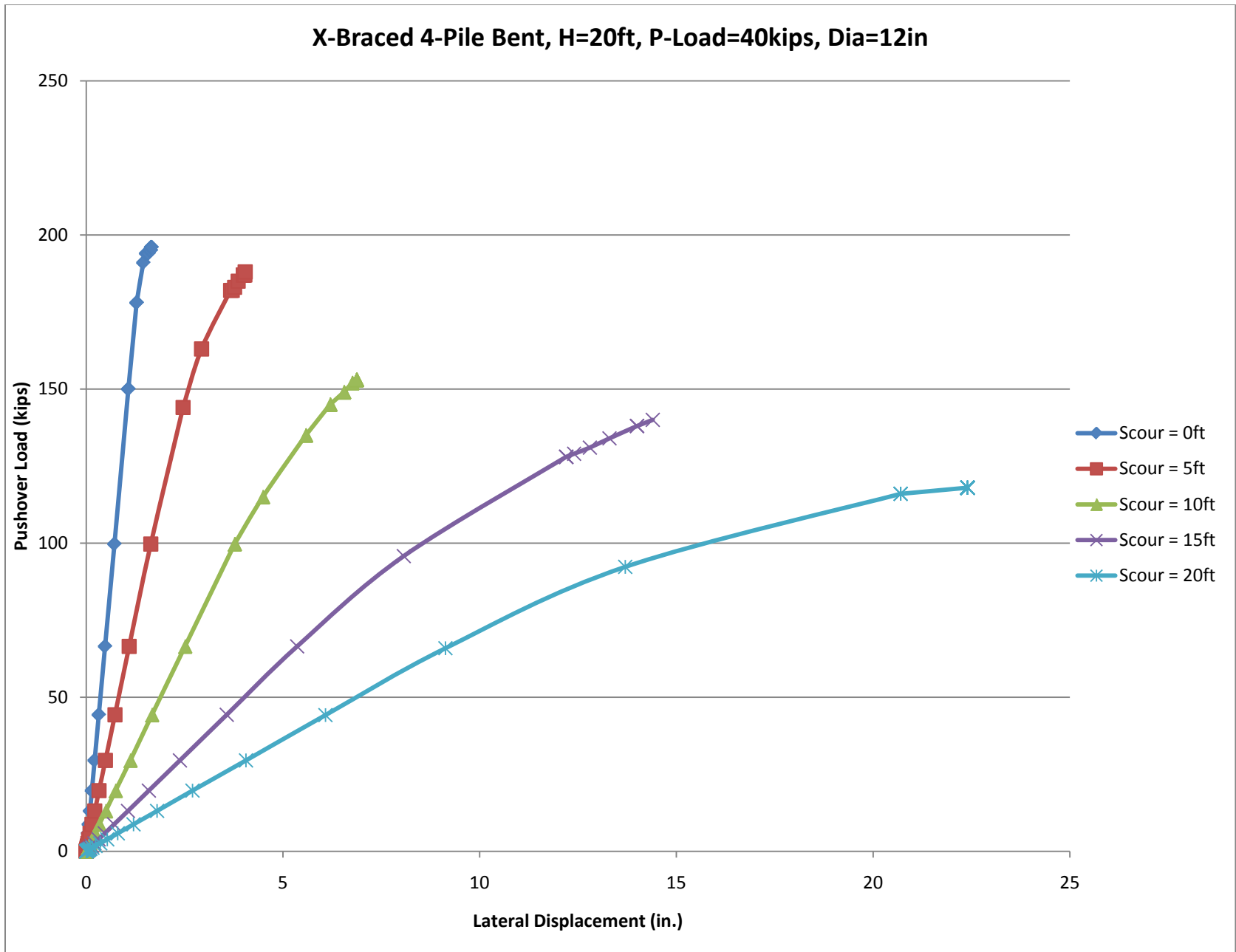


Figure A.47 Pushover Curves for X-Braced 4-Pile Bent, H=20ft, P=40kips, Diameter=12in, Multiple Levels of Scour

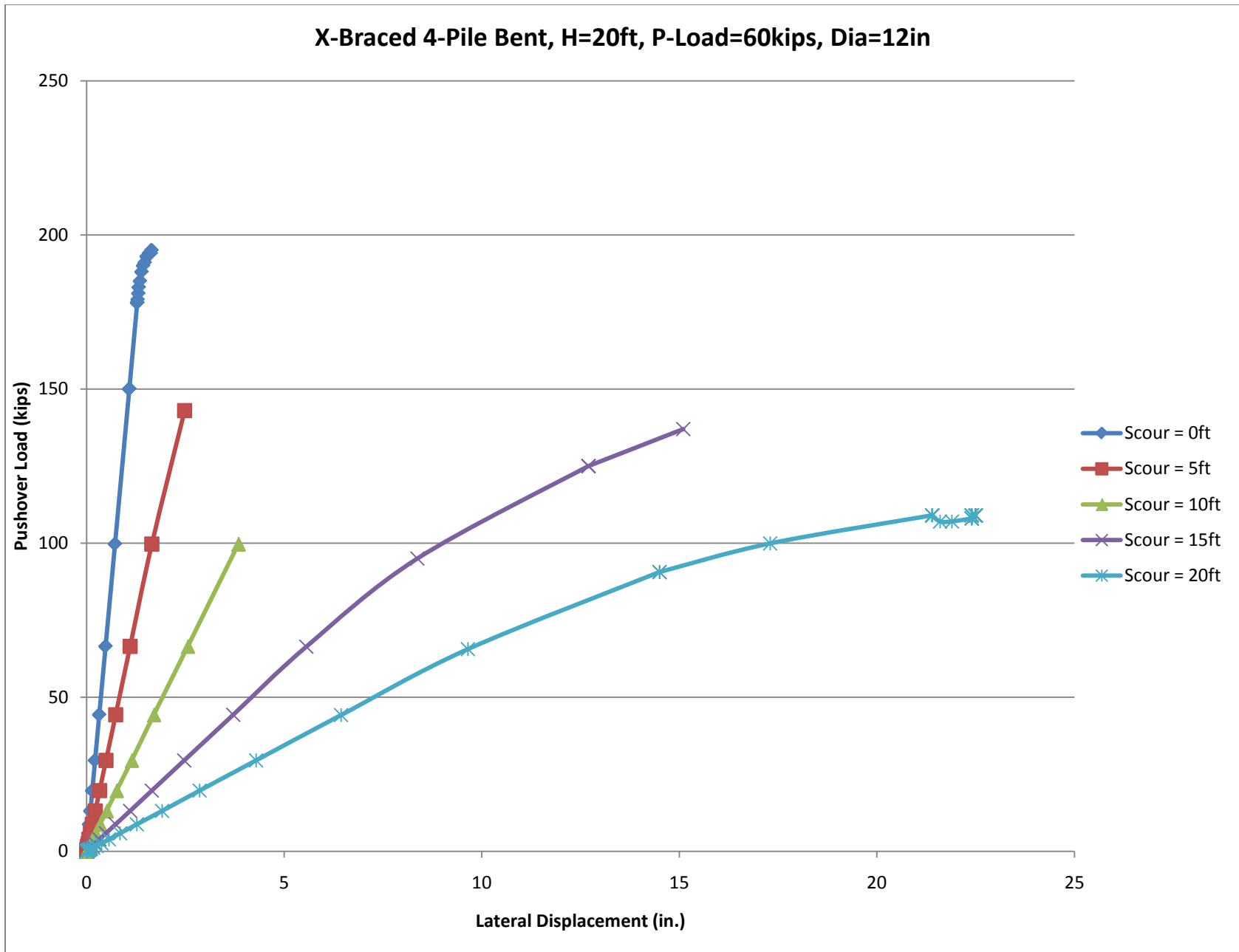
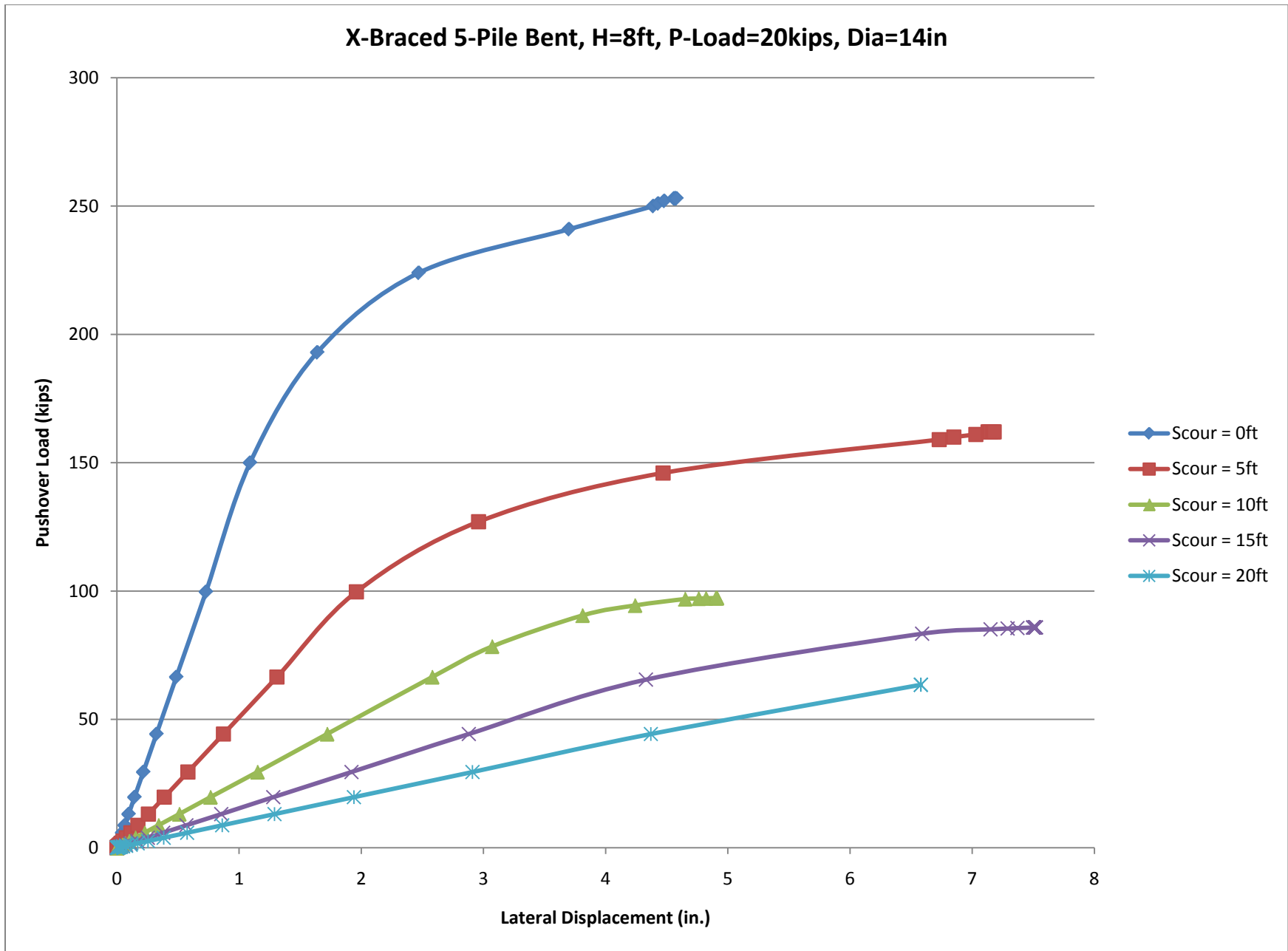
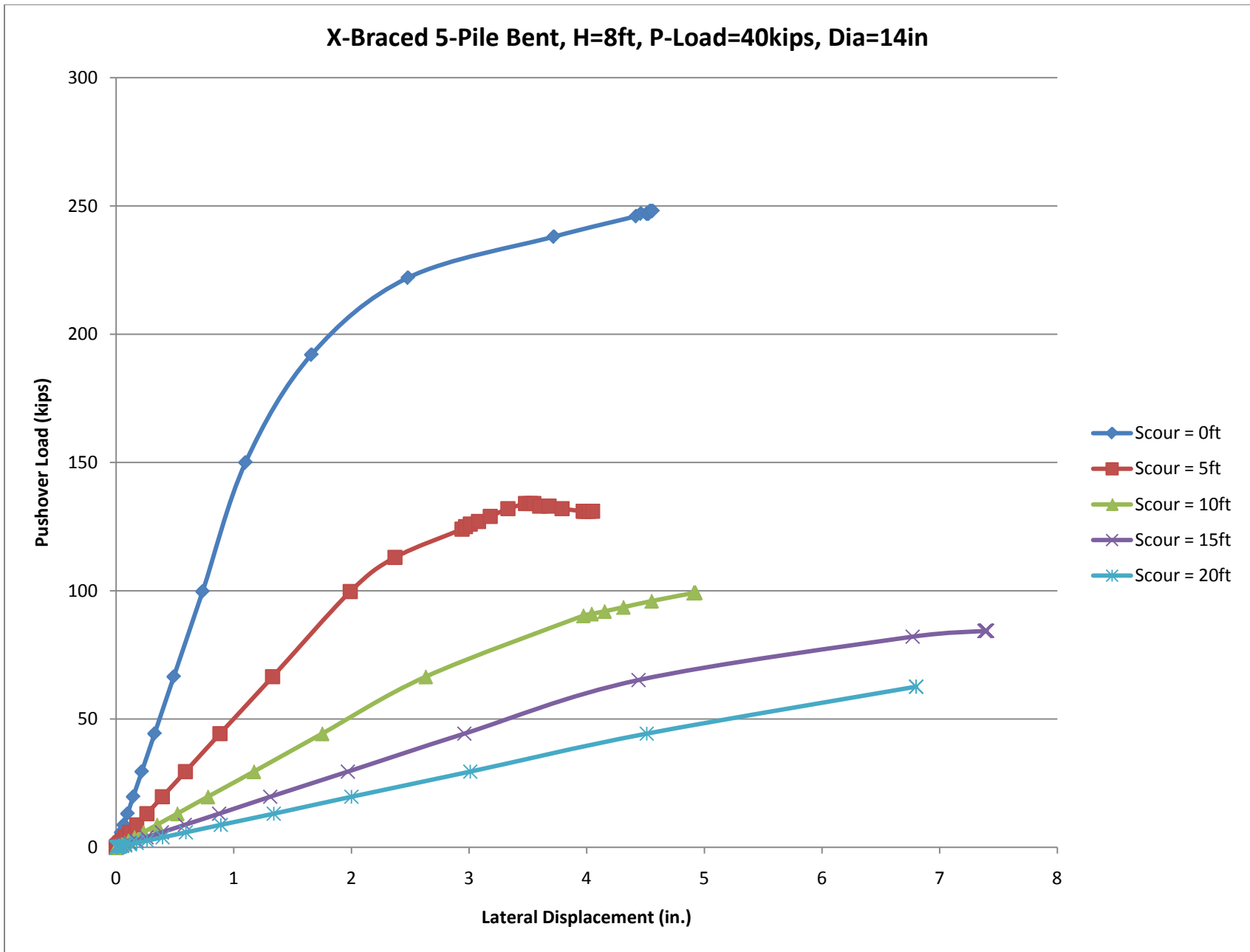


Figure A.48 Pushover Curves for X-Braced 4-Pile Bent, H=20ft, P=60kips, Diameter=12in, Multiple Levels of Scour

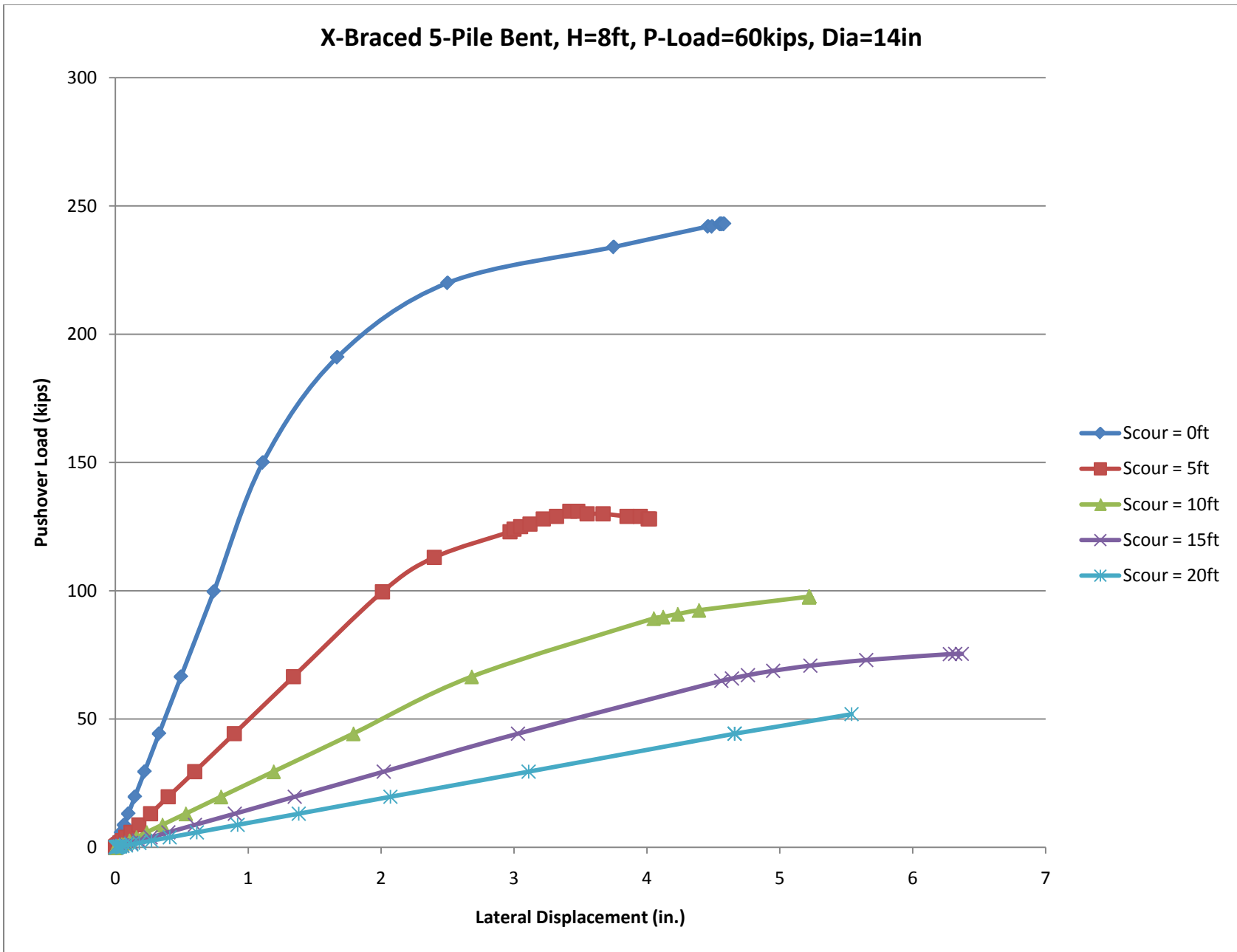


**Figure A.49 Pushover Curves for X-Braced 5-Pile Bent, H=8ft, P=20kips, Diameter=14in, Multiple Levels of Scour**

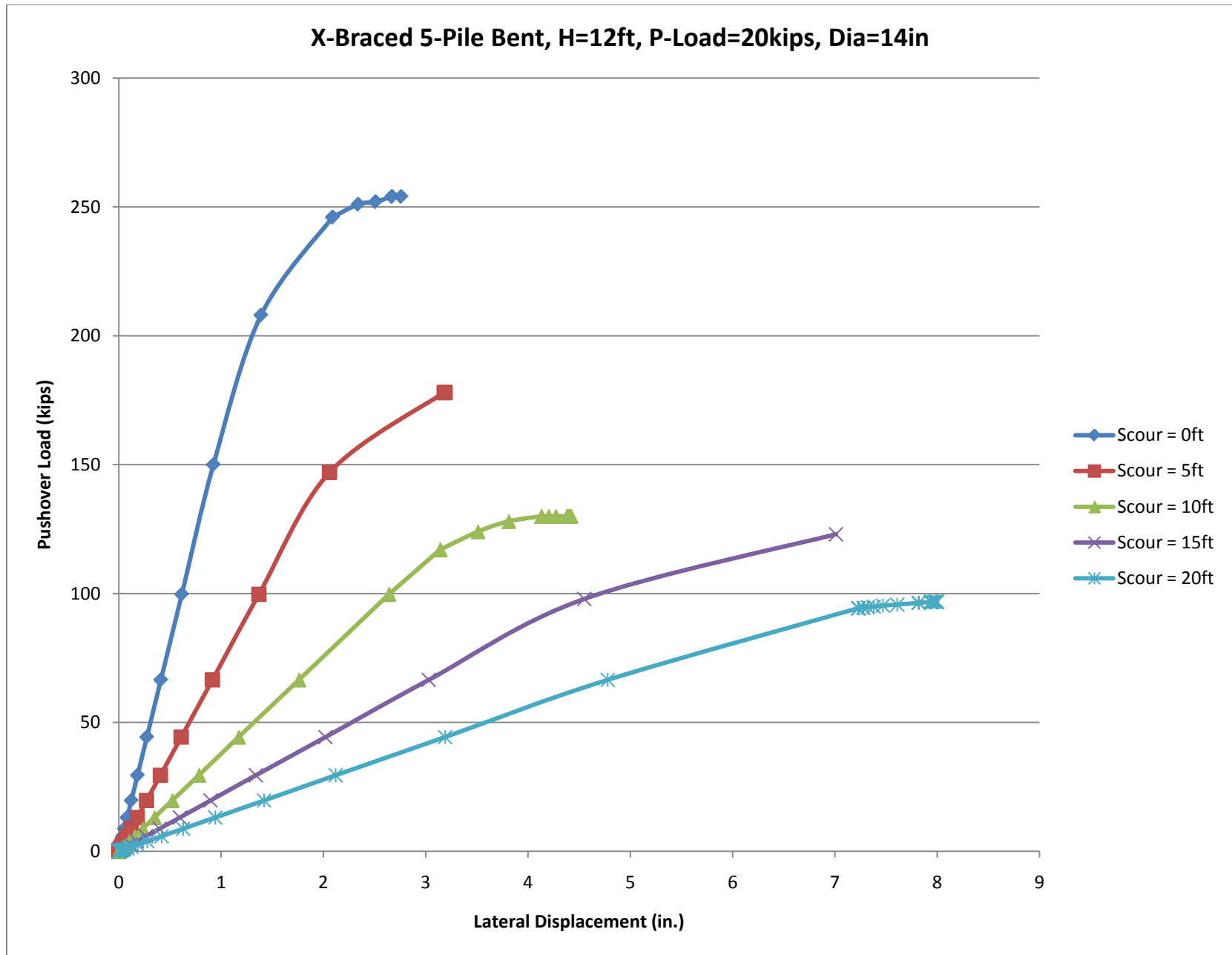


**Figure A.50 Pushover Curves for X-Braced 5-Pile Bent, H=8ft, P=40kips, Diameter=14in, Multiple Levels of Scour**

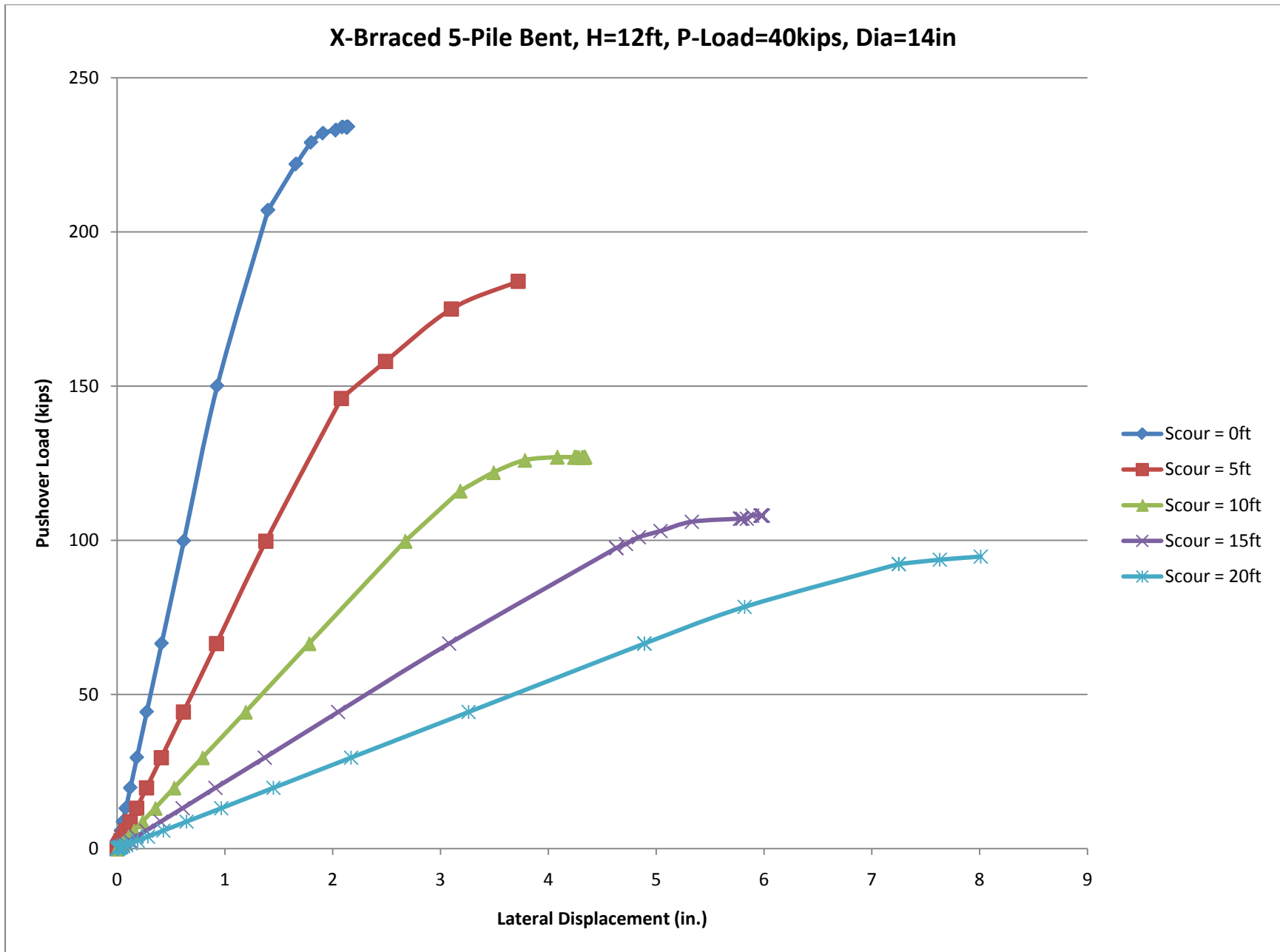




**Figure A.51 Pushover Curves for X-Braced 5-Pile Bent, H=8ft, P=60kips, Diameter=14in, Multiple Levels of Scour**



**Figure A.52 Pushover Curves for X-Braced 5-Pile Bent, H=12ft, P=20kips, Diameter=14in, Multiple Levels of Scour**



**Figure A.53 Pushover Curves for X-Braced 5-Pile Bent, H=12ft, P=40kips, Diameter=14in, Multiple Levels of Scour**

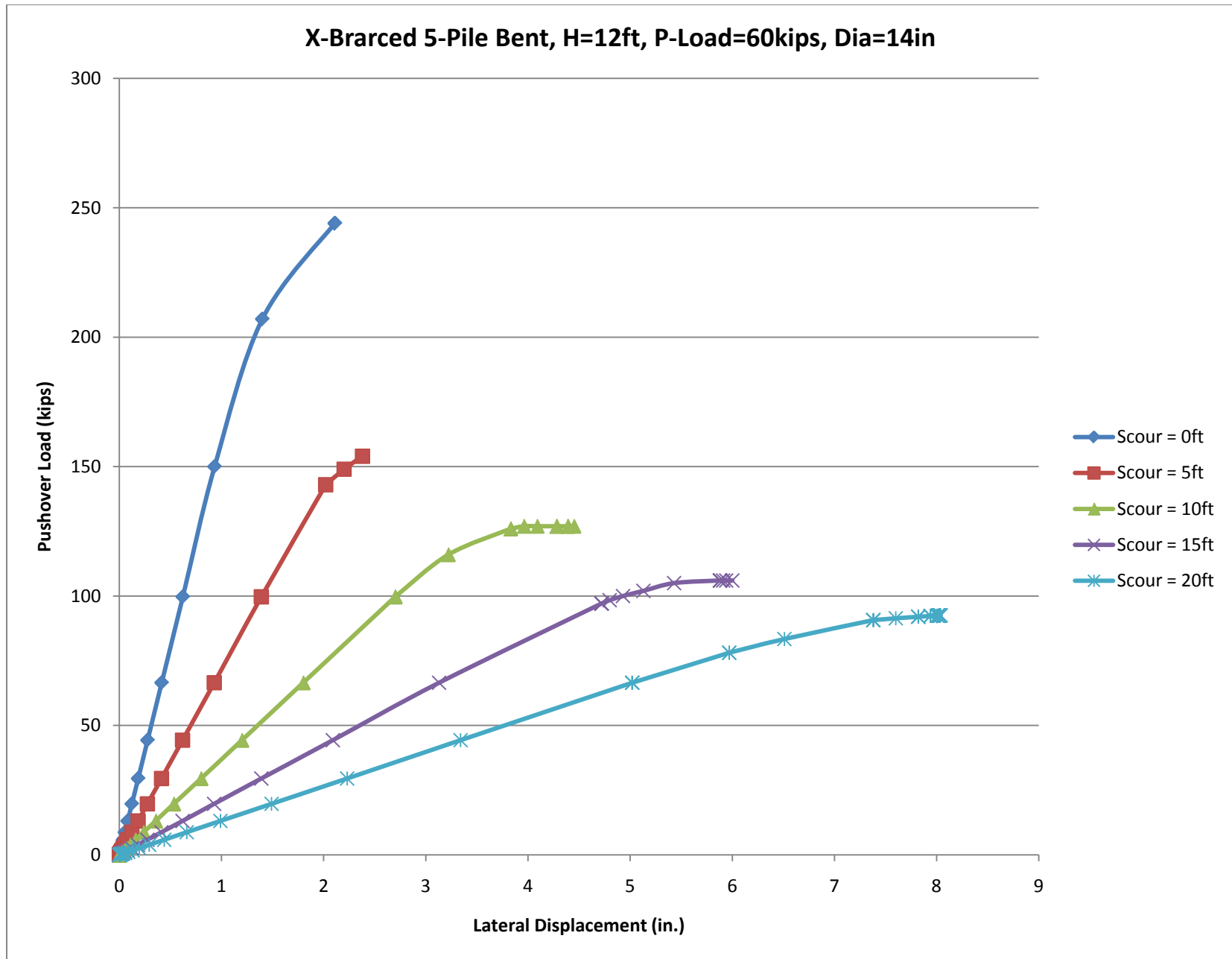


Figure A.54 Pushover Curves for X-Braced 5-Pile Bent, H=12ft, P=60kips, Diameter=14in, Multiple Levels of Scour

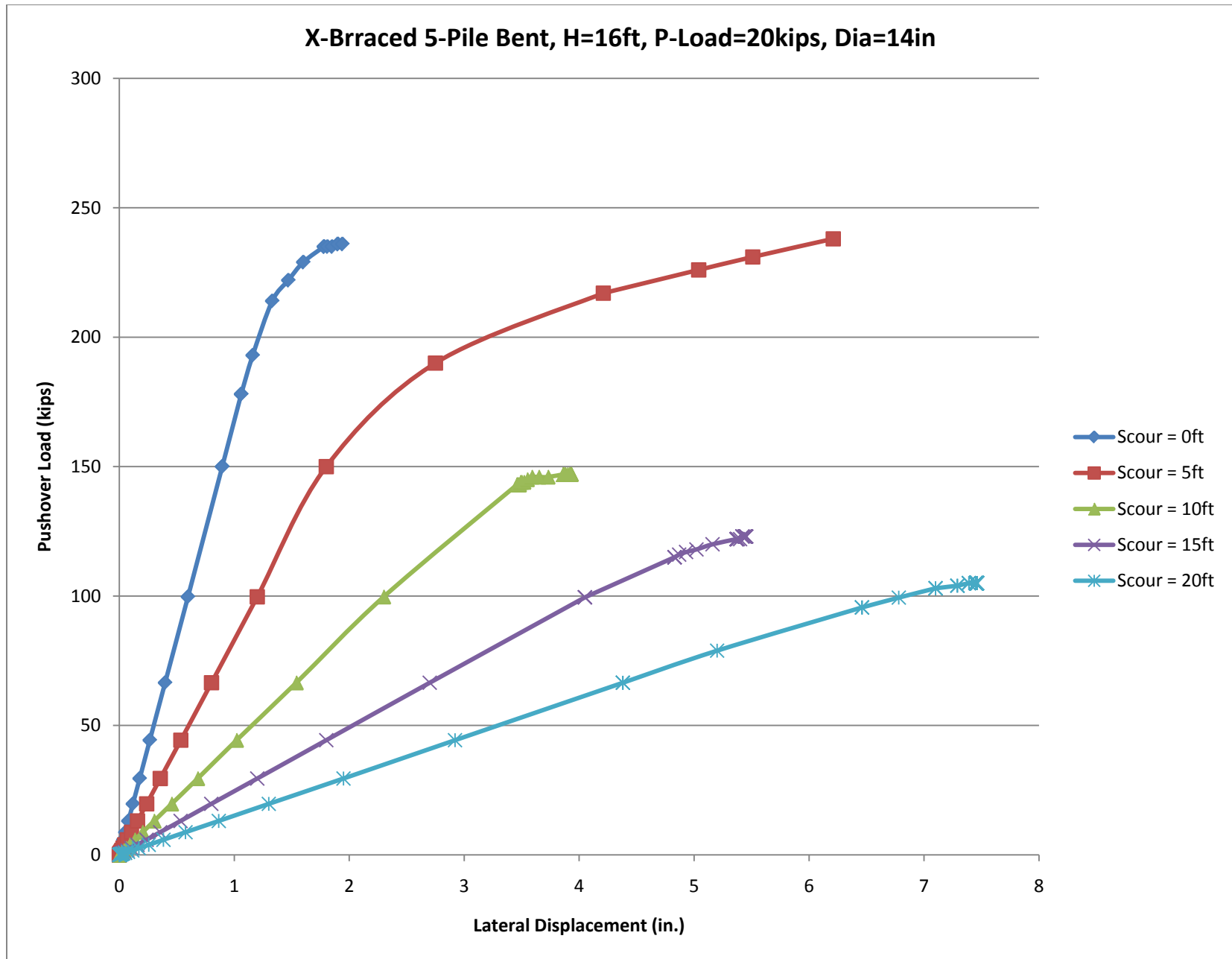
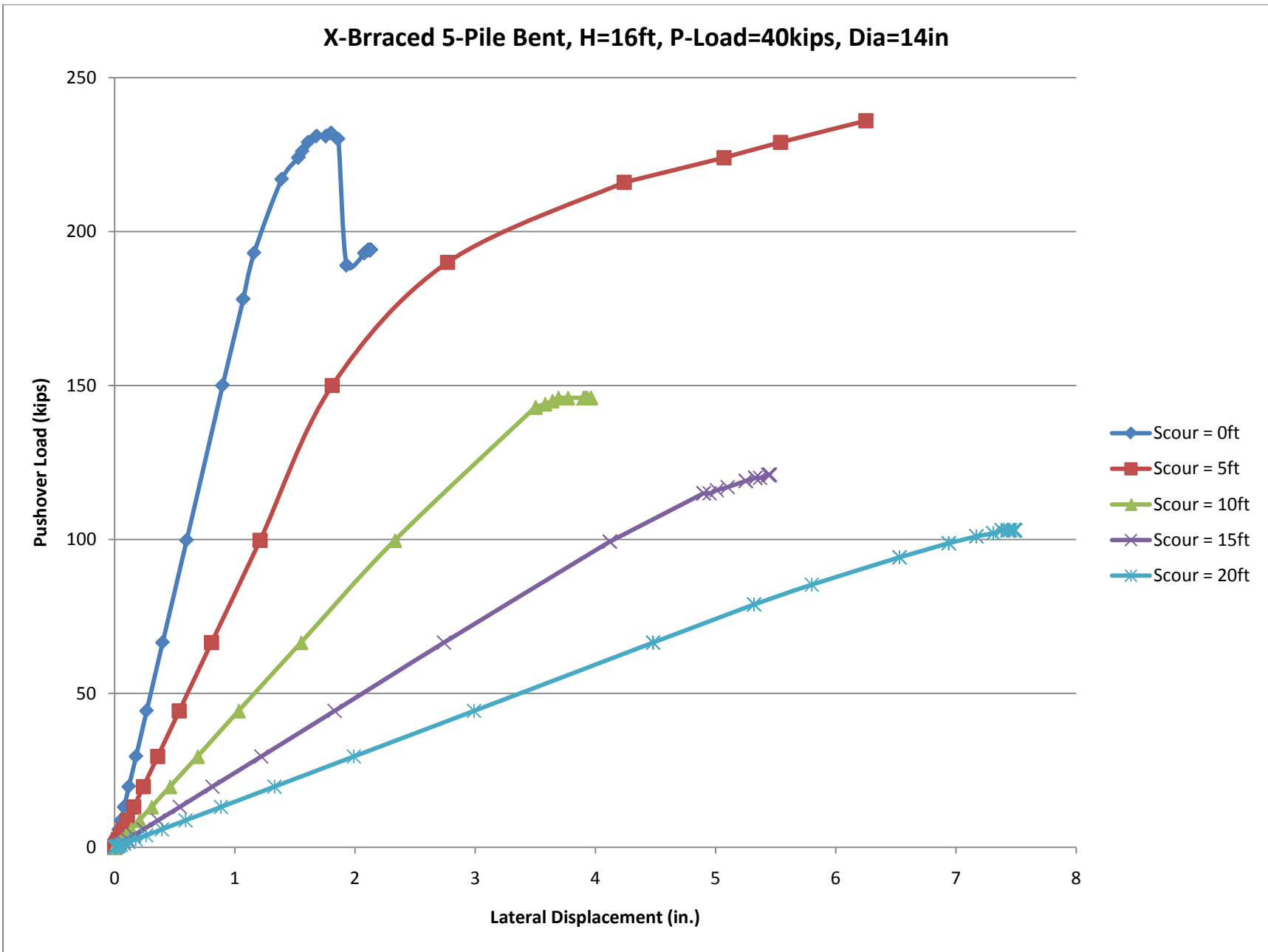


Figure A.55 Pushover Curves for X-Braced 5-Pile Bent, H=16ft, P=20kips, Diameter=14in, Multiple Levels of Scour



**Figure A.56 Pushover Curves for X-Braced 5-Pile Bent, H=16ft, P=40kips, Diameter=14in, Multiple Levels of Scour**

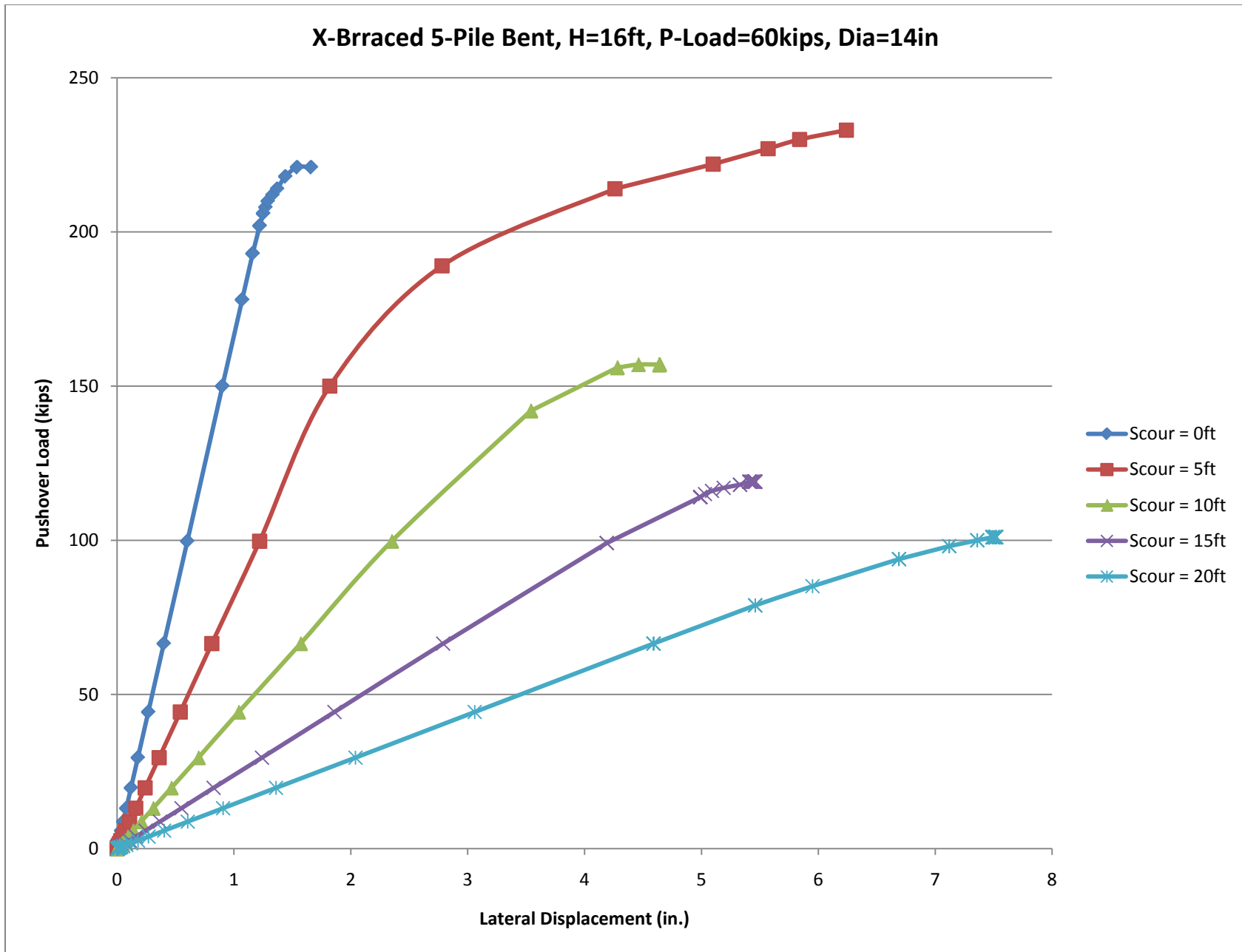


Figure A.57 Pushover Curves for X-Braced 5-Pile Bent, H=20ft, P=60kips, Diameter=14in, Multiple Levels of Scour

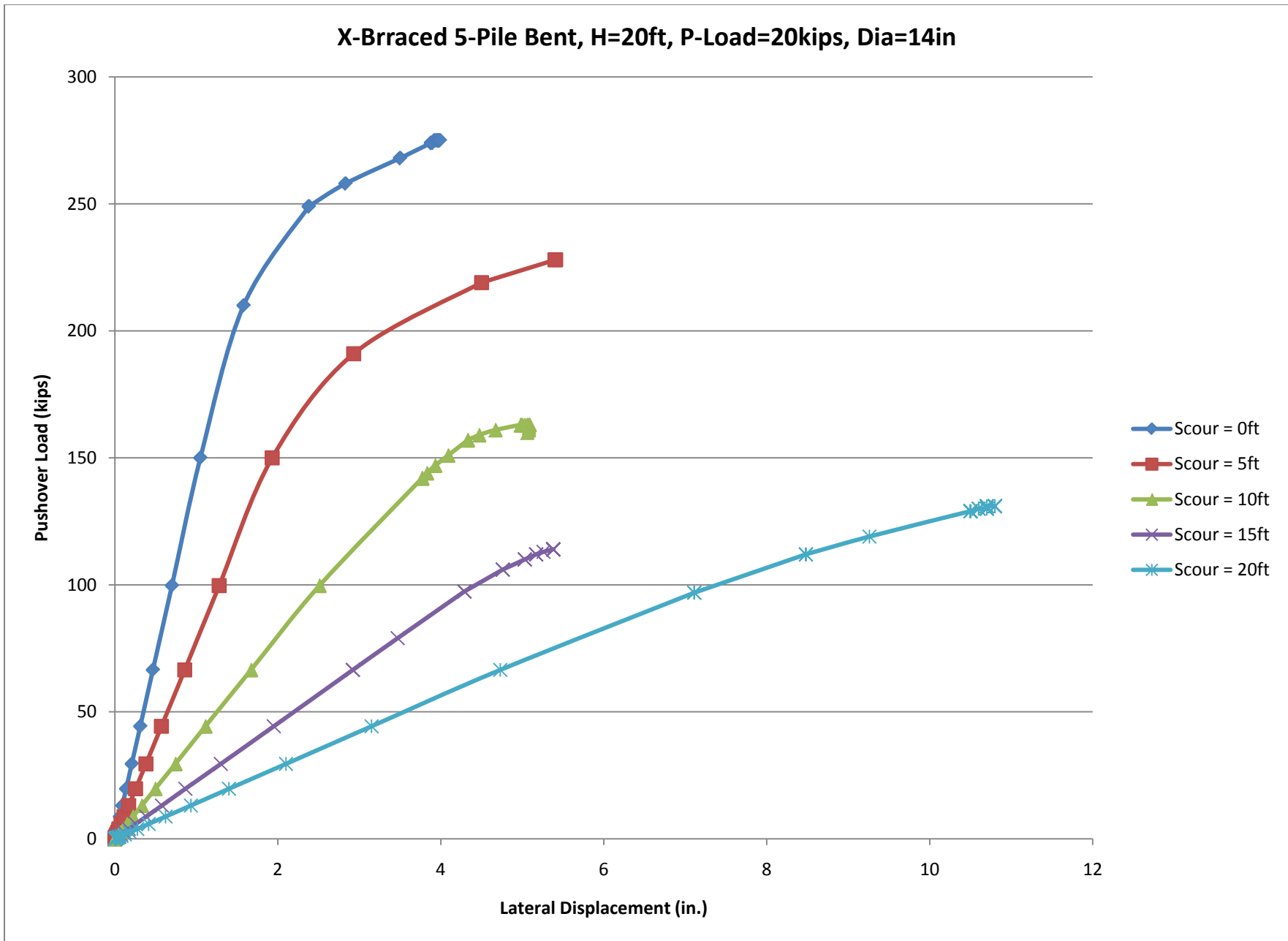


Figure A.58 Pushover Curves for X-Braced 5-Pile Bent, H=20ft, P=20kips, Diameter=14in, Multiple Levels of Scour



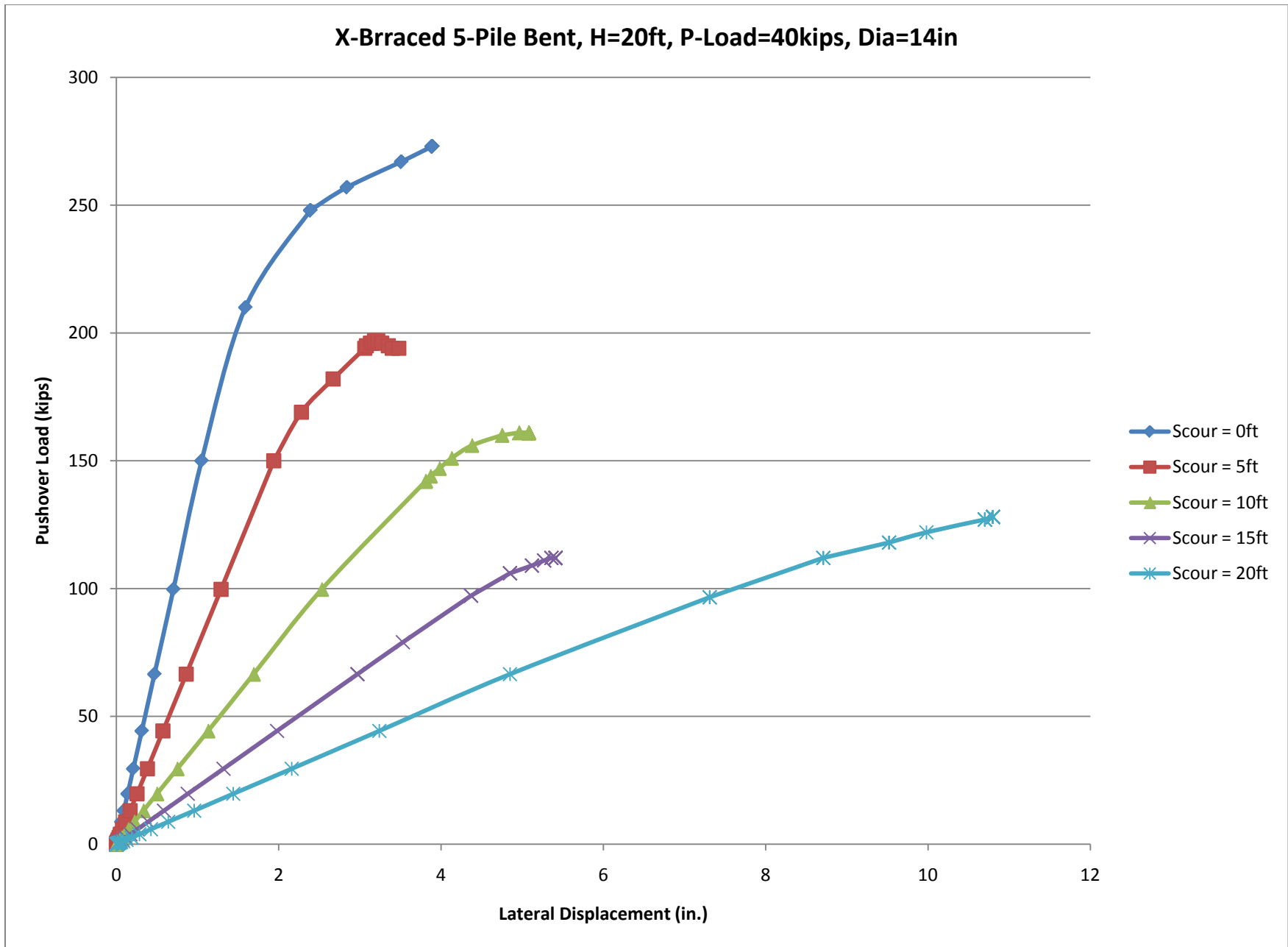
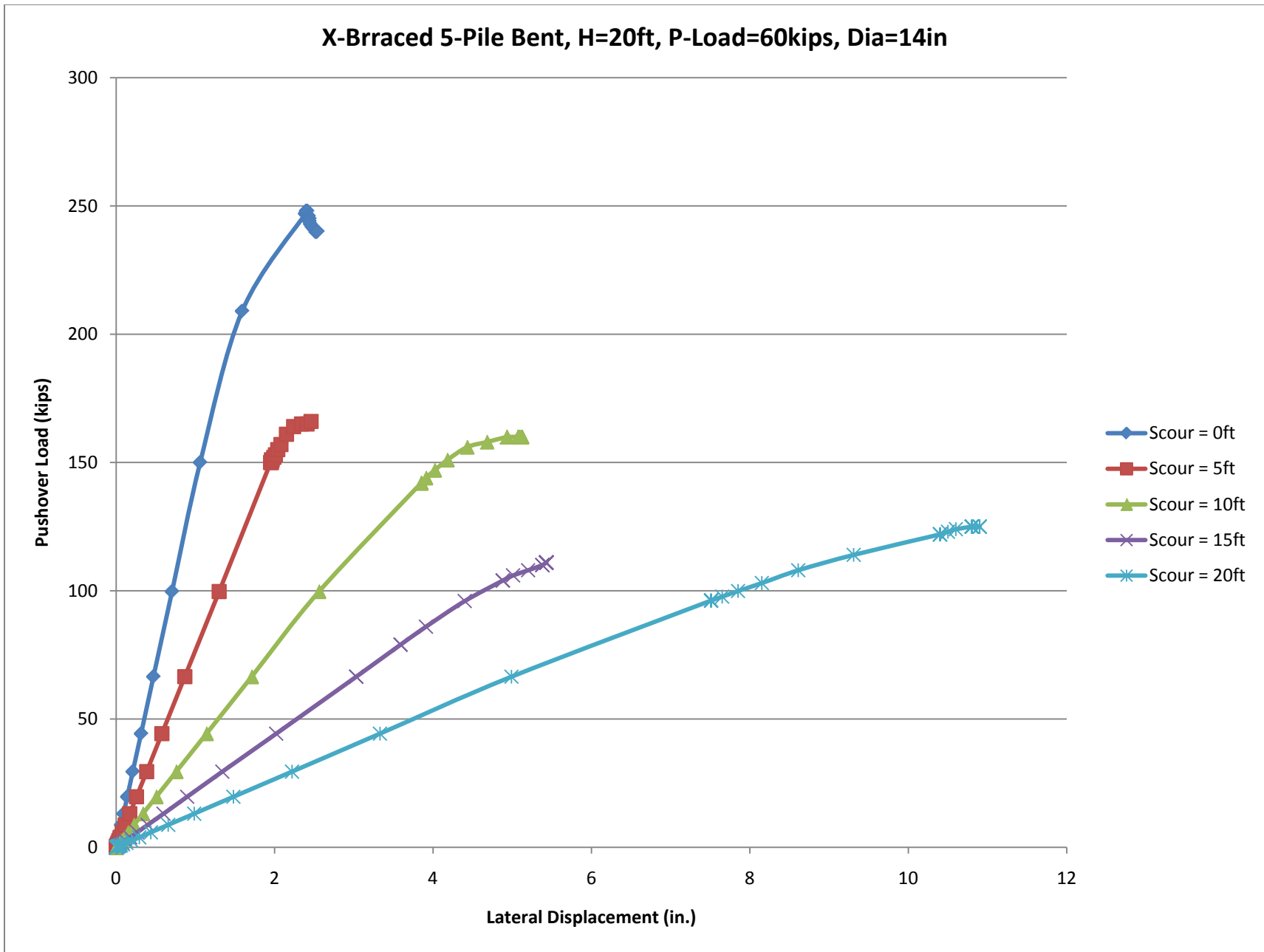
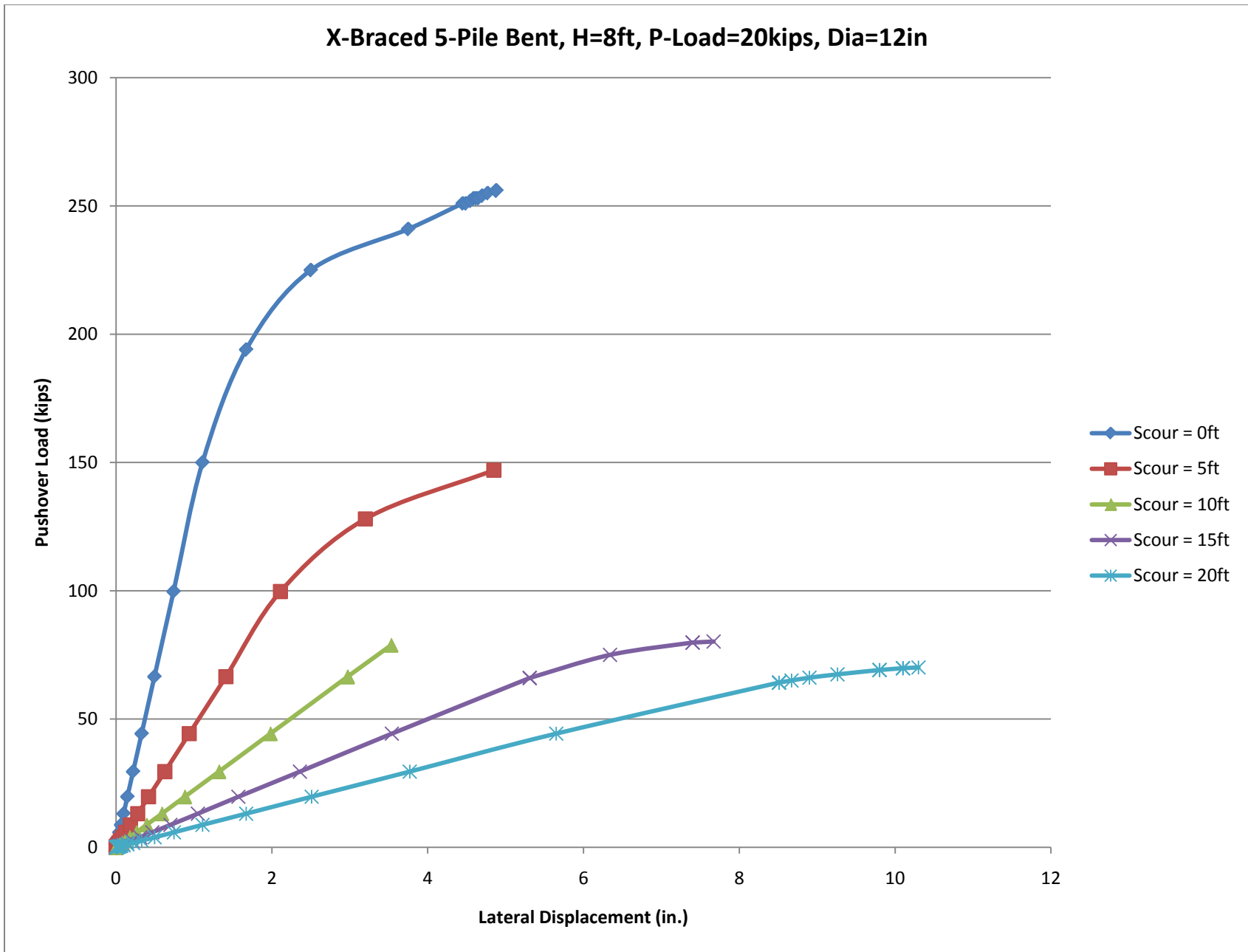


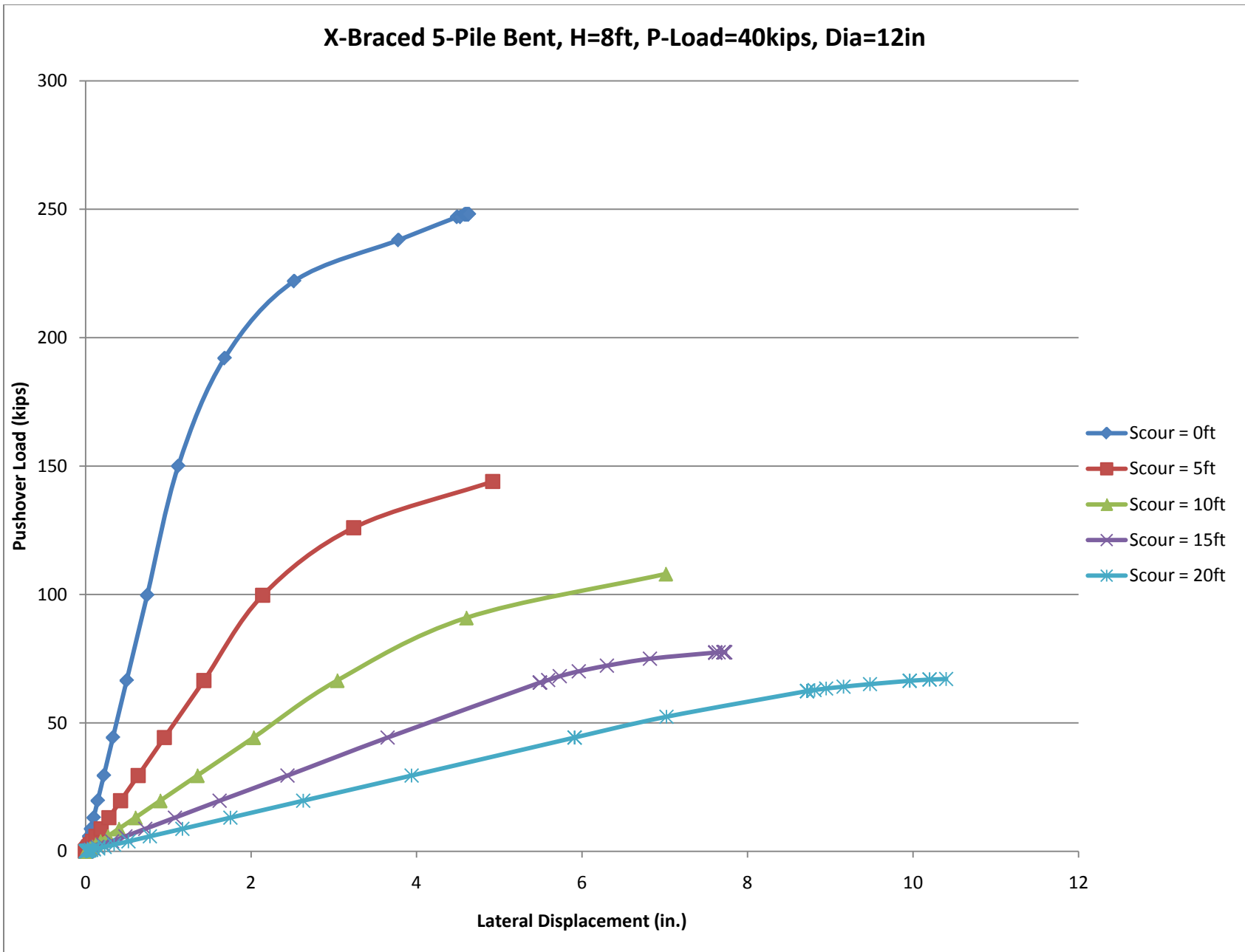
Figure A.59 Pushover Curves for X-Braced 5-Pile Bent, H=20ft, P=40kips, Diameter=14in, Multiple Levels of Scour



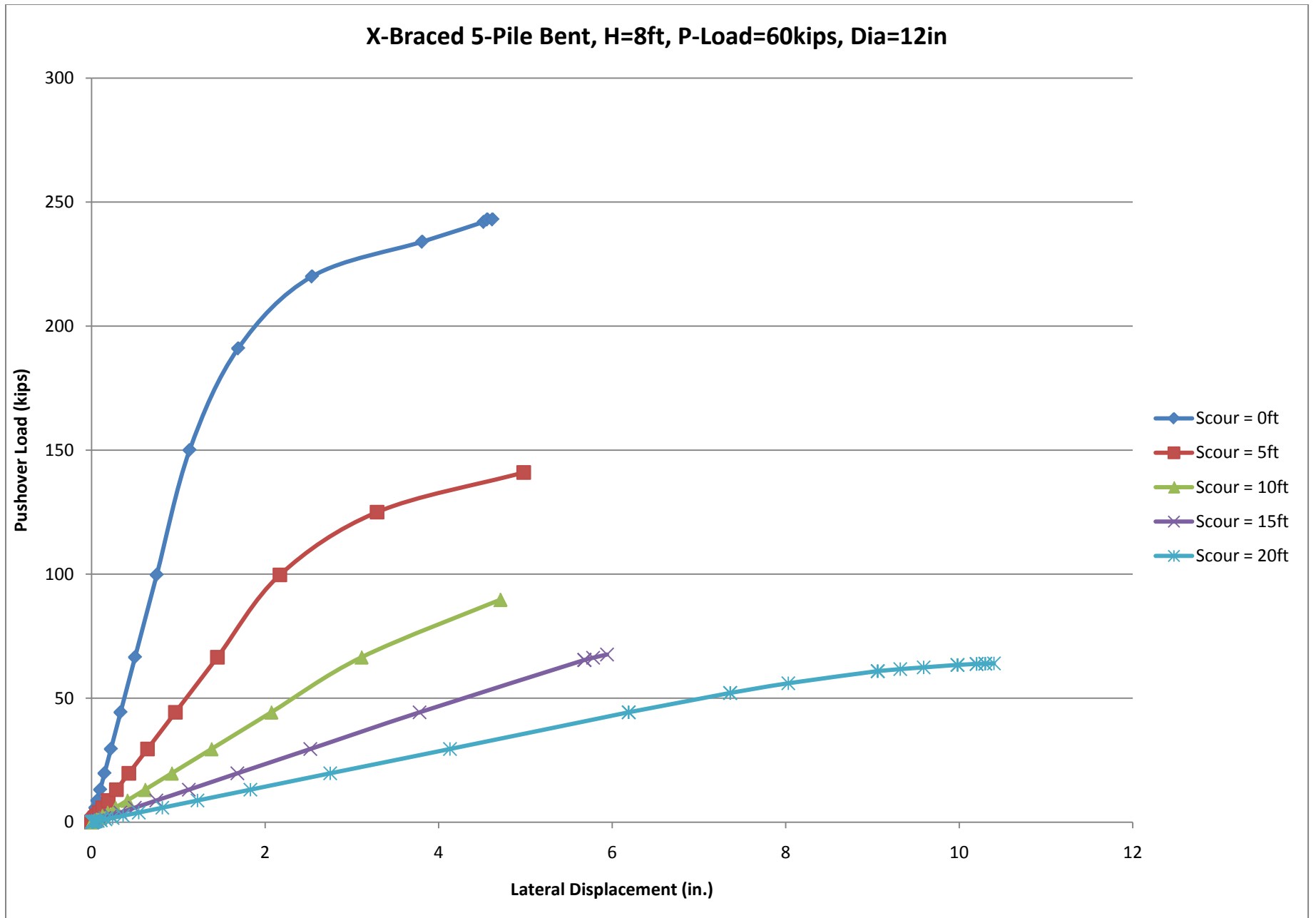
**Figure A.60 Pushover Curves for X-Braced 5-Pile Bent, H=20ft, P=60kips, Diameter=14in, Multiple Levels of Scour**



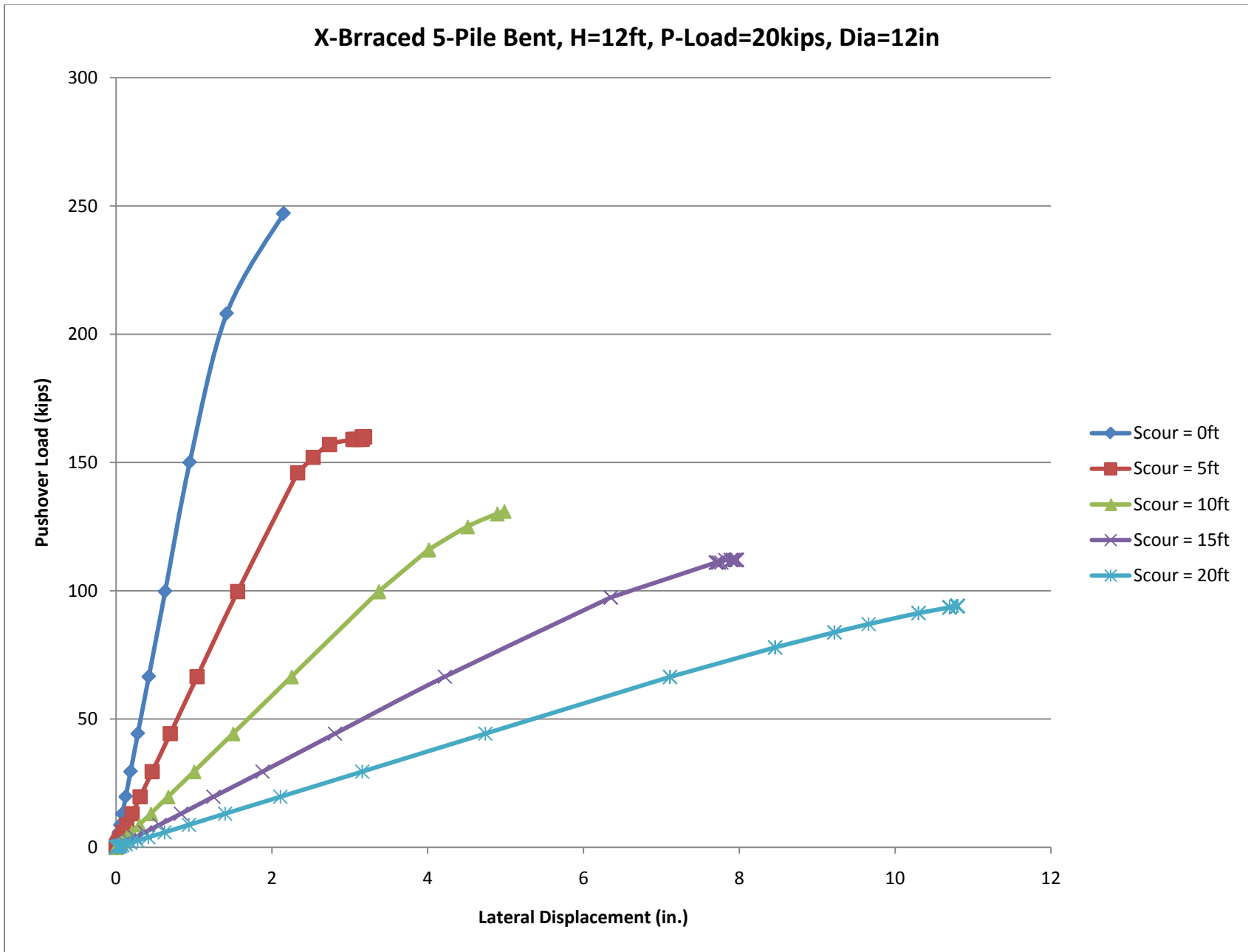
**Figure A.61 Pushover Curves for X-Braced 5-Pile Bent, H=8ft, P=20kips, Diameter=12in, Multiple Levels of Scour**



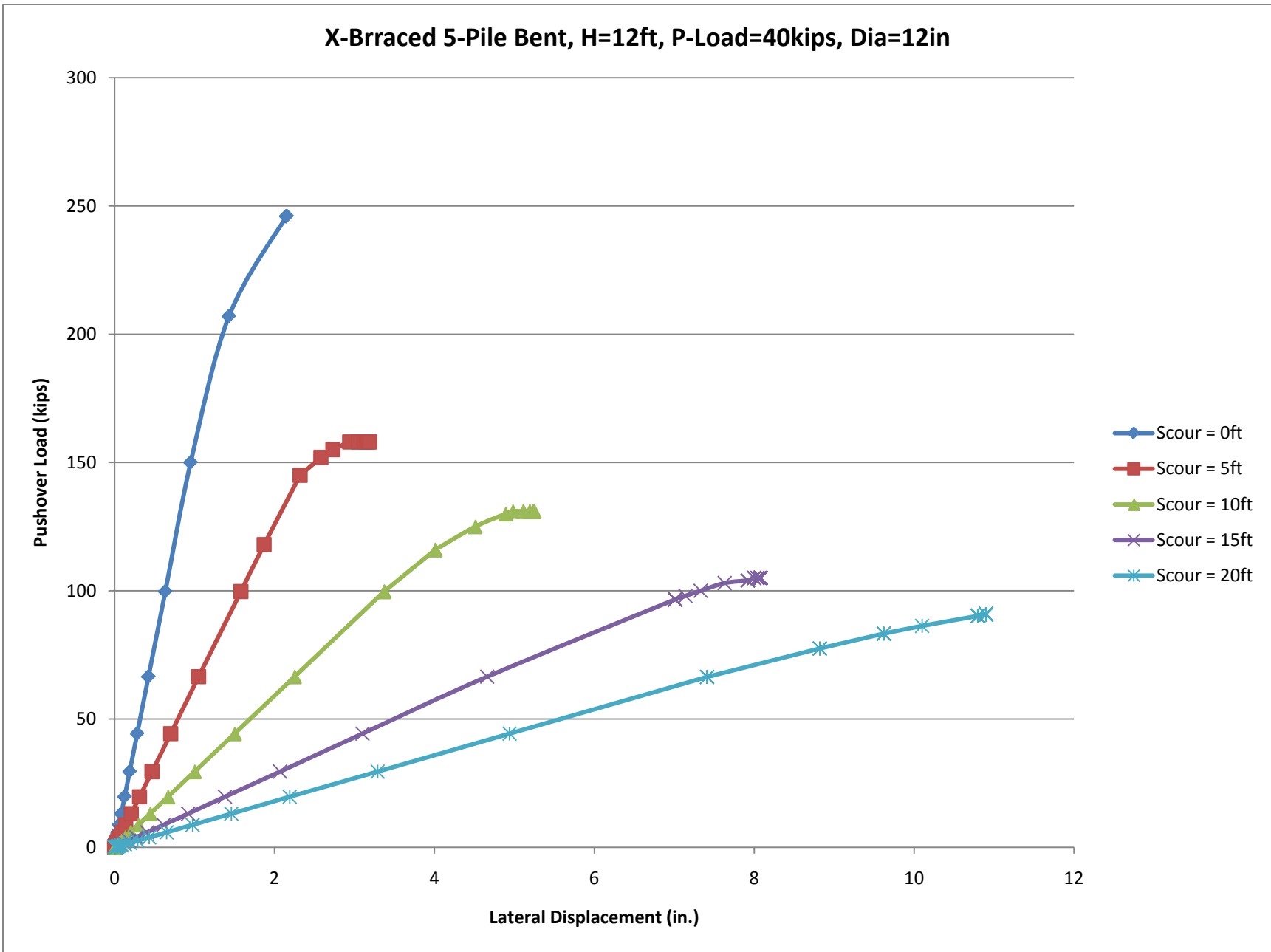
**Figure A.62 Pushover Curves for X-Braced 5-Pile Bent, H=8ft, P=40kips, Diameter=12in, Multiple Levels of Scour**



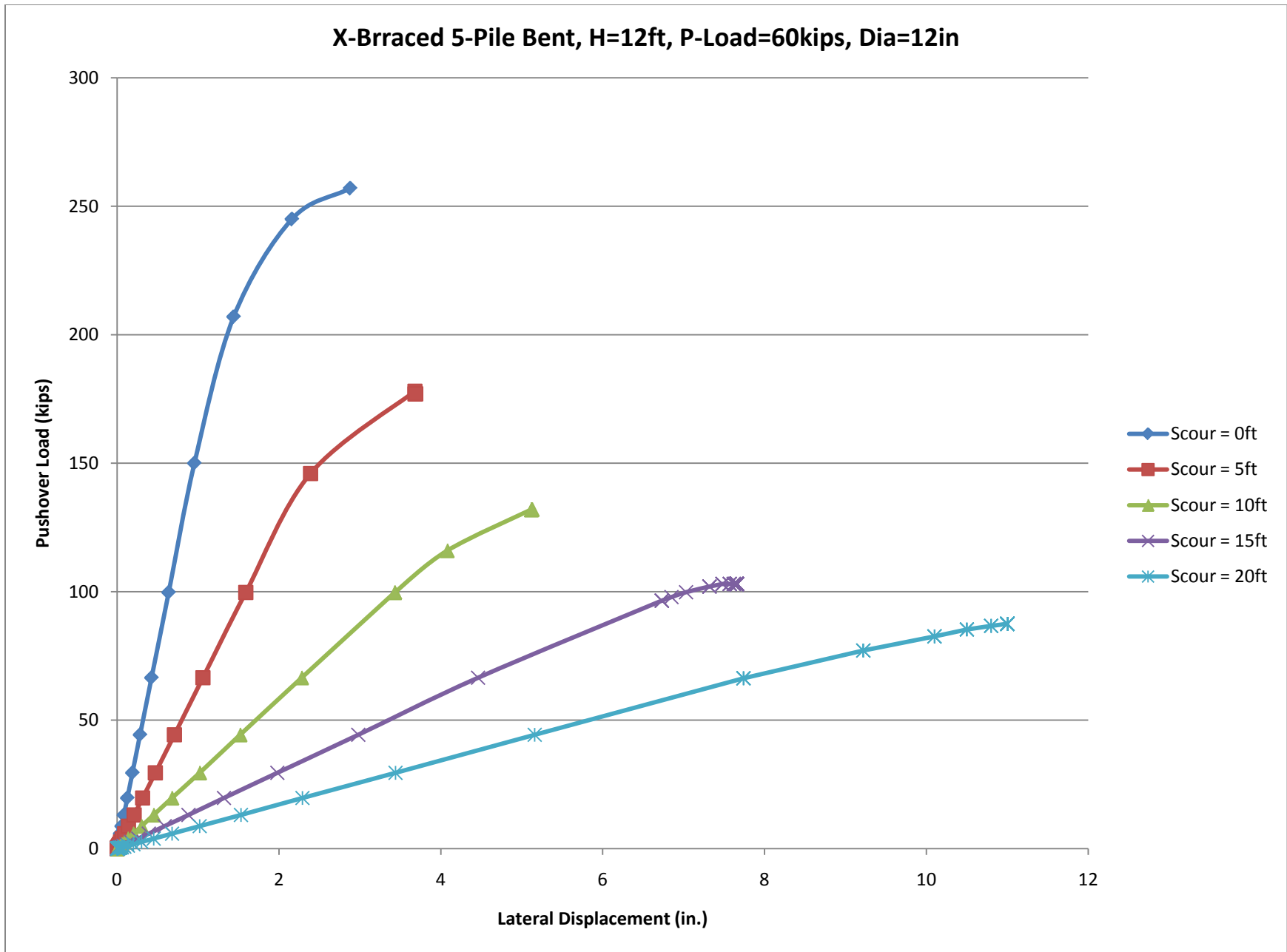
**Figure A.63 Pushover Curves for X-Braced 5-Pile Bent, H=8ft, P=60kips, Diameter=12in, Multiple Levels of Scour**



**Figure A.64 Pushover Curves for X-Braced 5-Pile Bent, H=12ft, P=20kips, Diameter=12in, Multiple Levels of Scour**

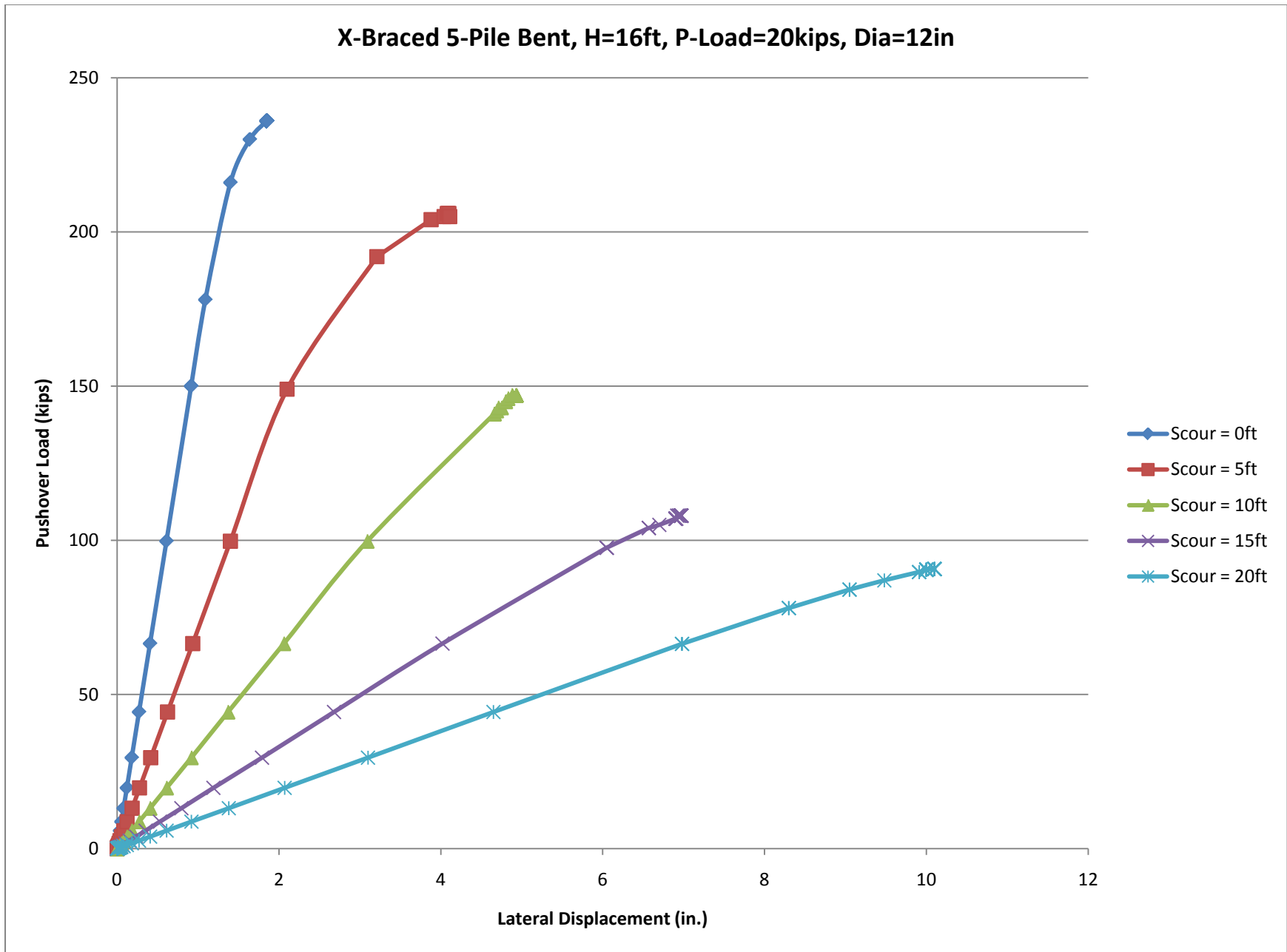


**Figure A.65 Pushover Curves for X-Braced 5-Pile Bent, H=12ft, P=40kips, Diameter=12in, Multiple Levels of Scour**



**Figure A.66 Pushover Curves for X-Braced 5-Pile Bent, H=12ft, P=60kips, Diameter=12in, Multiple Levels of Scour**





**Figure A.67 Pushover Curves for X-Braced 5-Pile Bent, H=16ft, P=20kips, Diameter=12in, Multiple Levels of Scour**

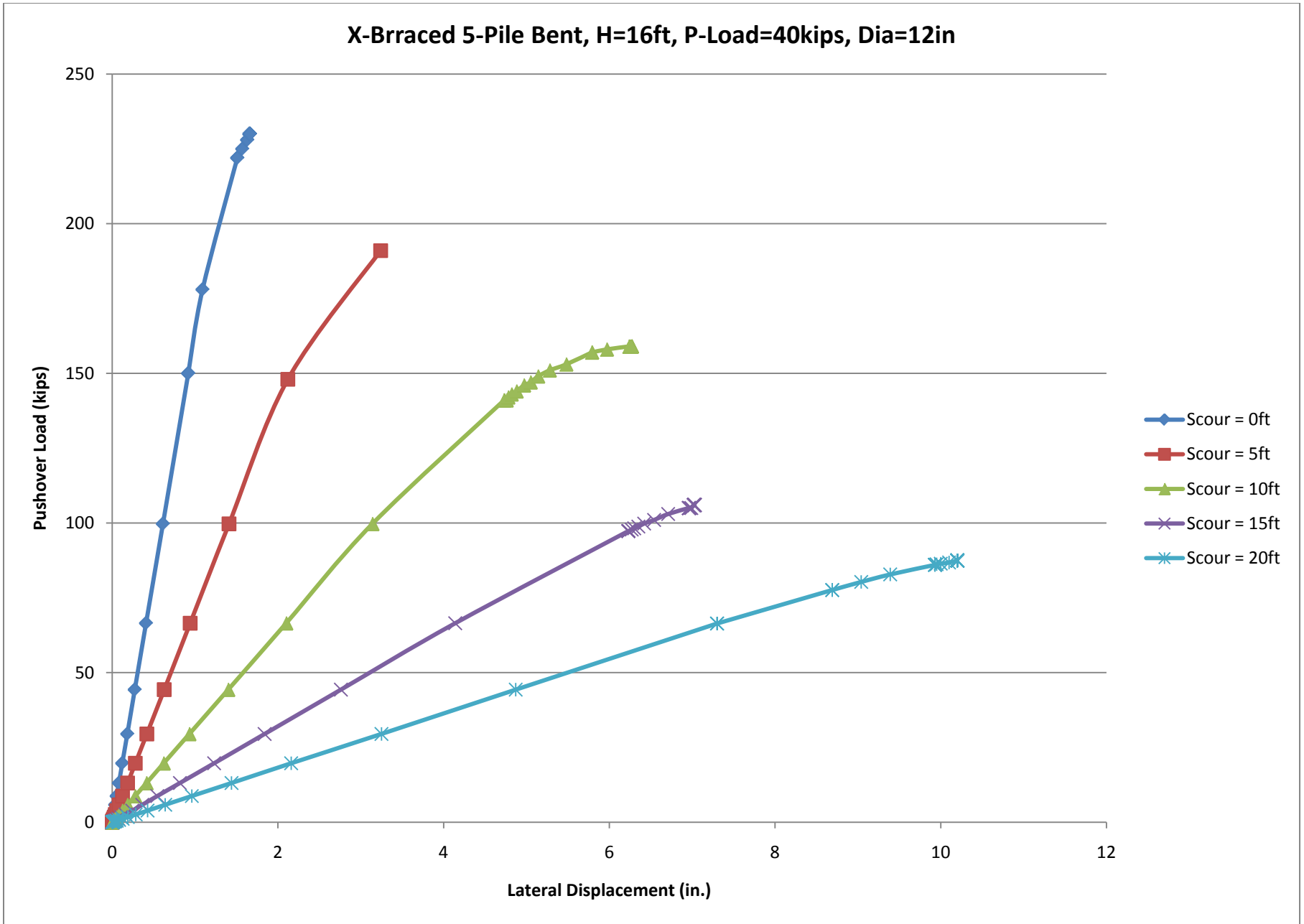


Figure A.68 Pushover Curves for X-Braced 5-Pile Bent, H=16ft, P=40kips, Diameter=12in, Multiple Levels of Scour

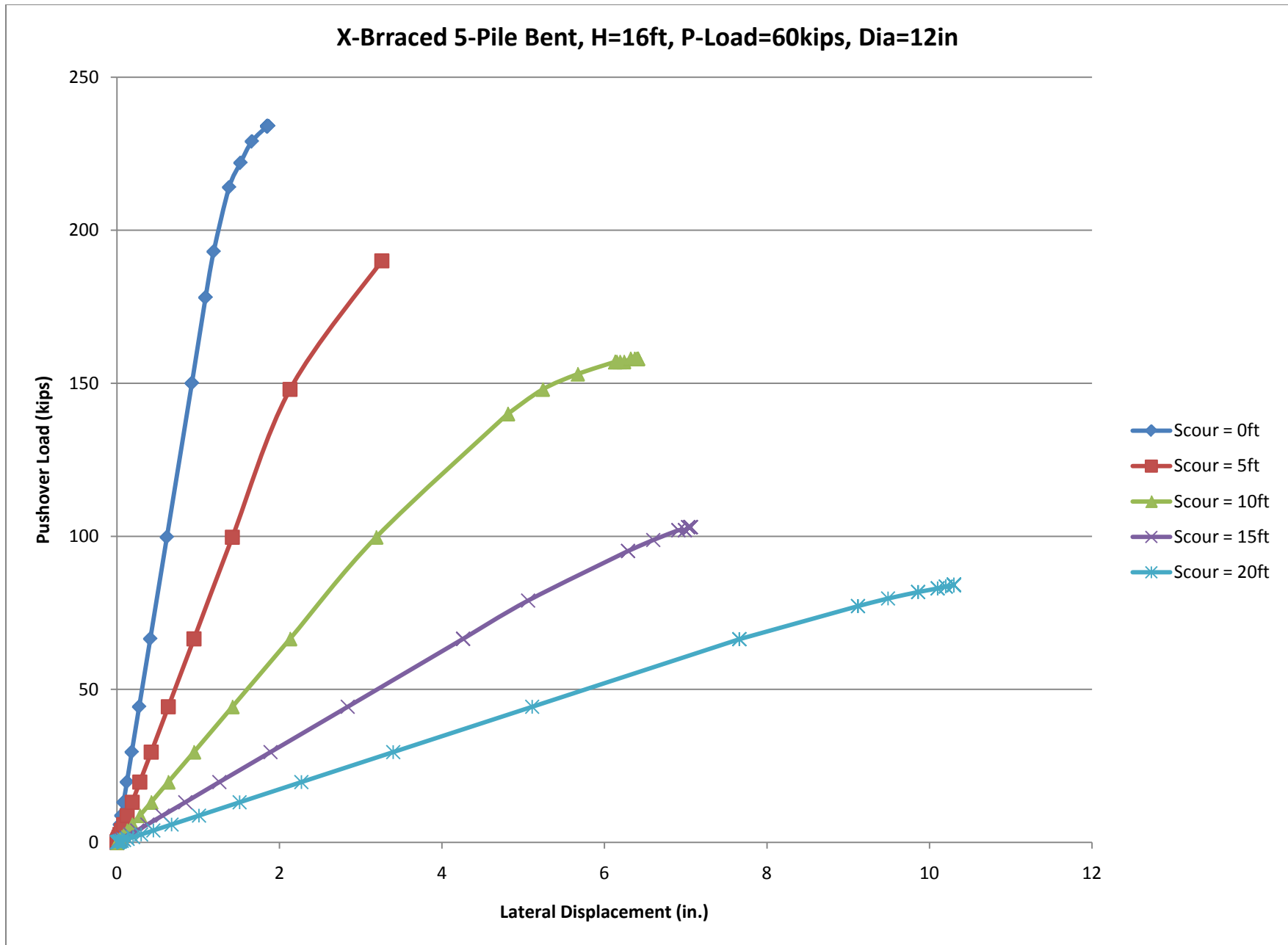
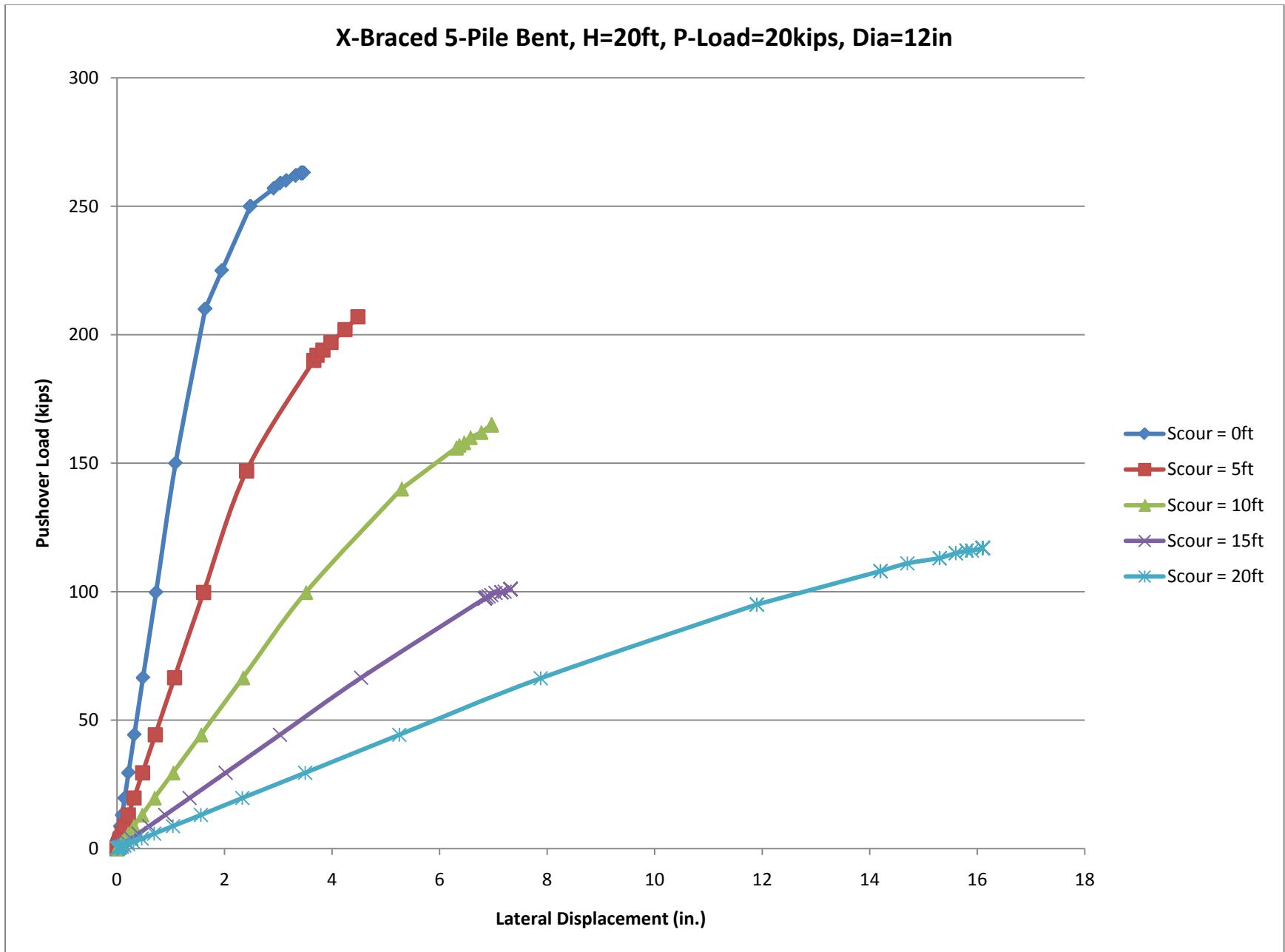


Figure A.69 Pushover Curves for X-Braced 5-Pile Bent, H=20ft, P=60kips, Diameter=12in, Multiple Levels of Scour



**Figure A.70 Pushover Curves for X-Braced 5-Pile Bent, H=20ft, P=20kips, Diameter=12in, Multiple Levels of Scour**

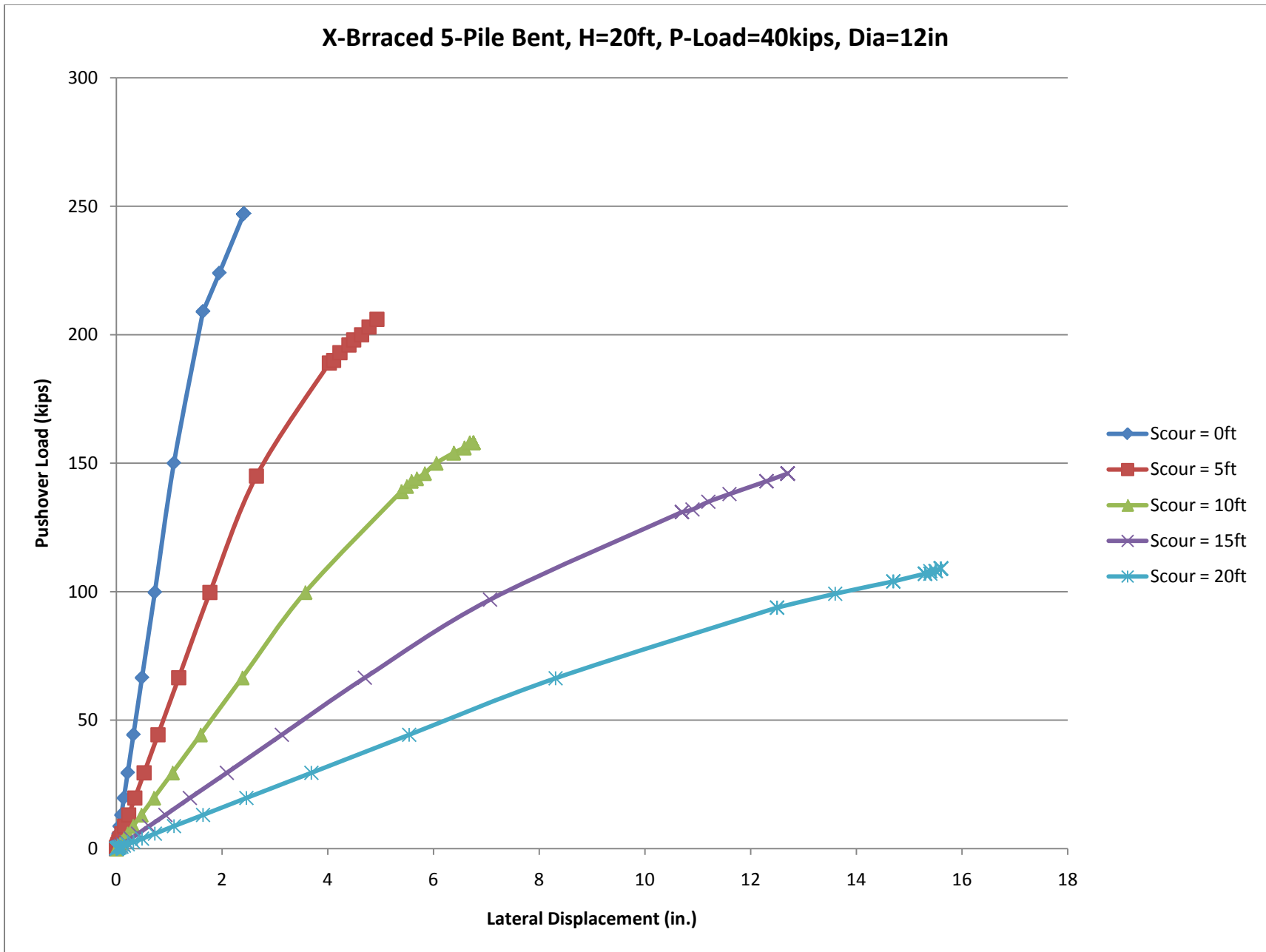


Figure A.71 Pushover Curves for X-Braced 5-Pile Bent, H=20ft, P=40kips, Diameter=12in, Multiple Levels of Scour

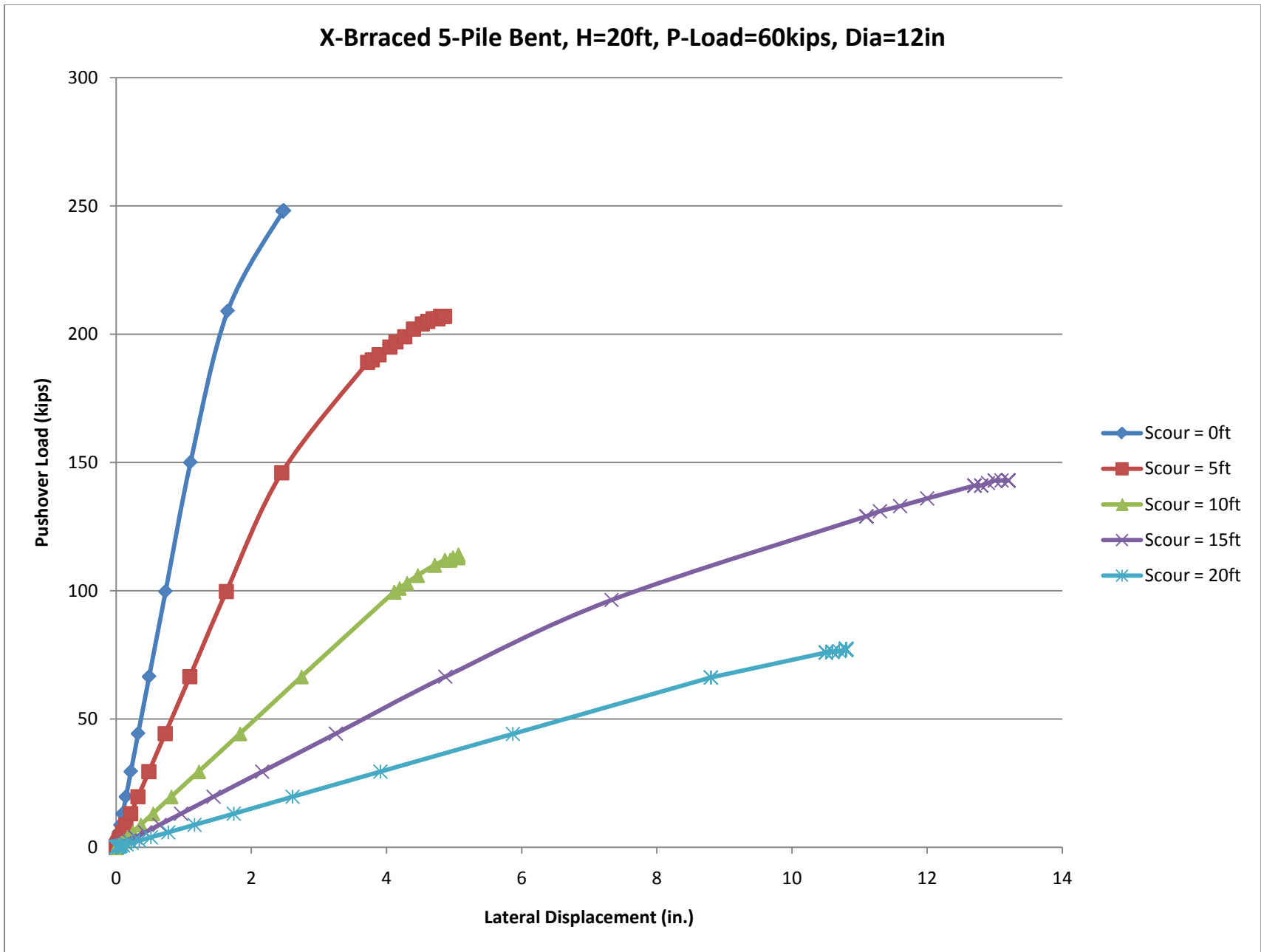
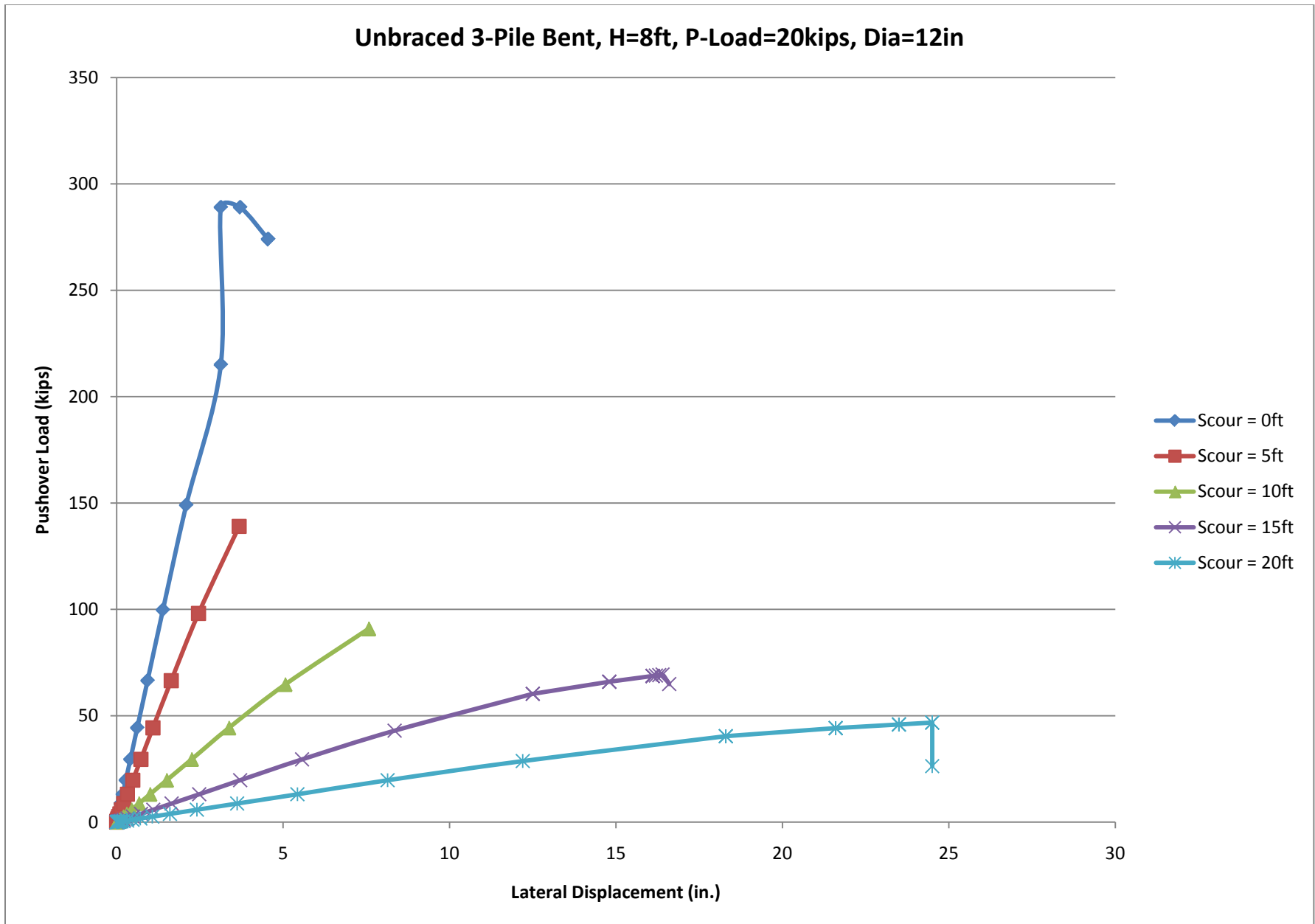


Figure A.72 Pushover Curves for X-Braced 5-Pile Bent, H=20ft, P=60kips, Diameter=12in, Multiple Levels of Scour

## **APPENDIX B**

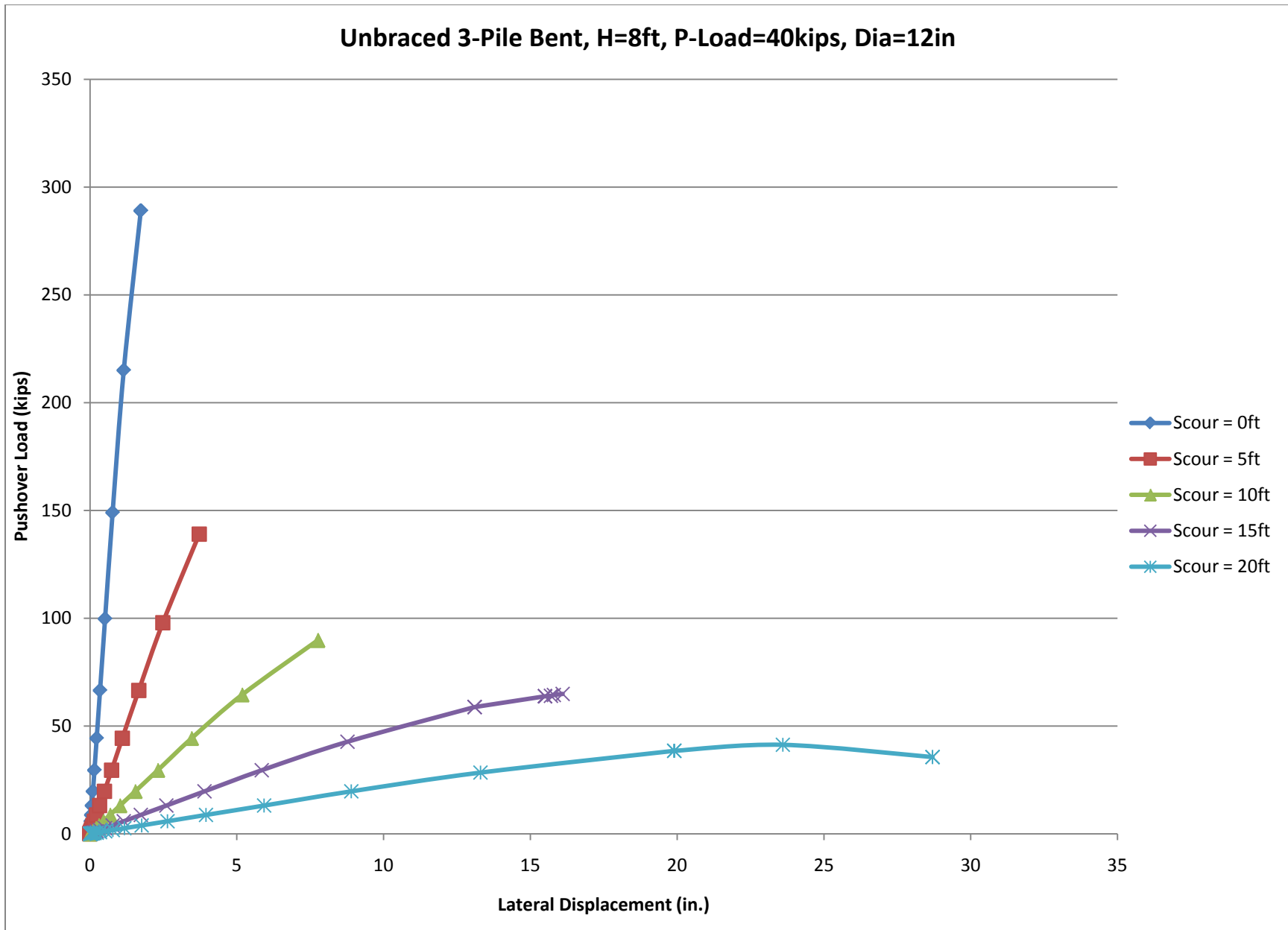
### **Unbraced Timber Pile Bent**

#### **$F_t$ vs $\Delta$ Pushover Curves**

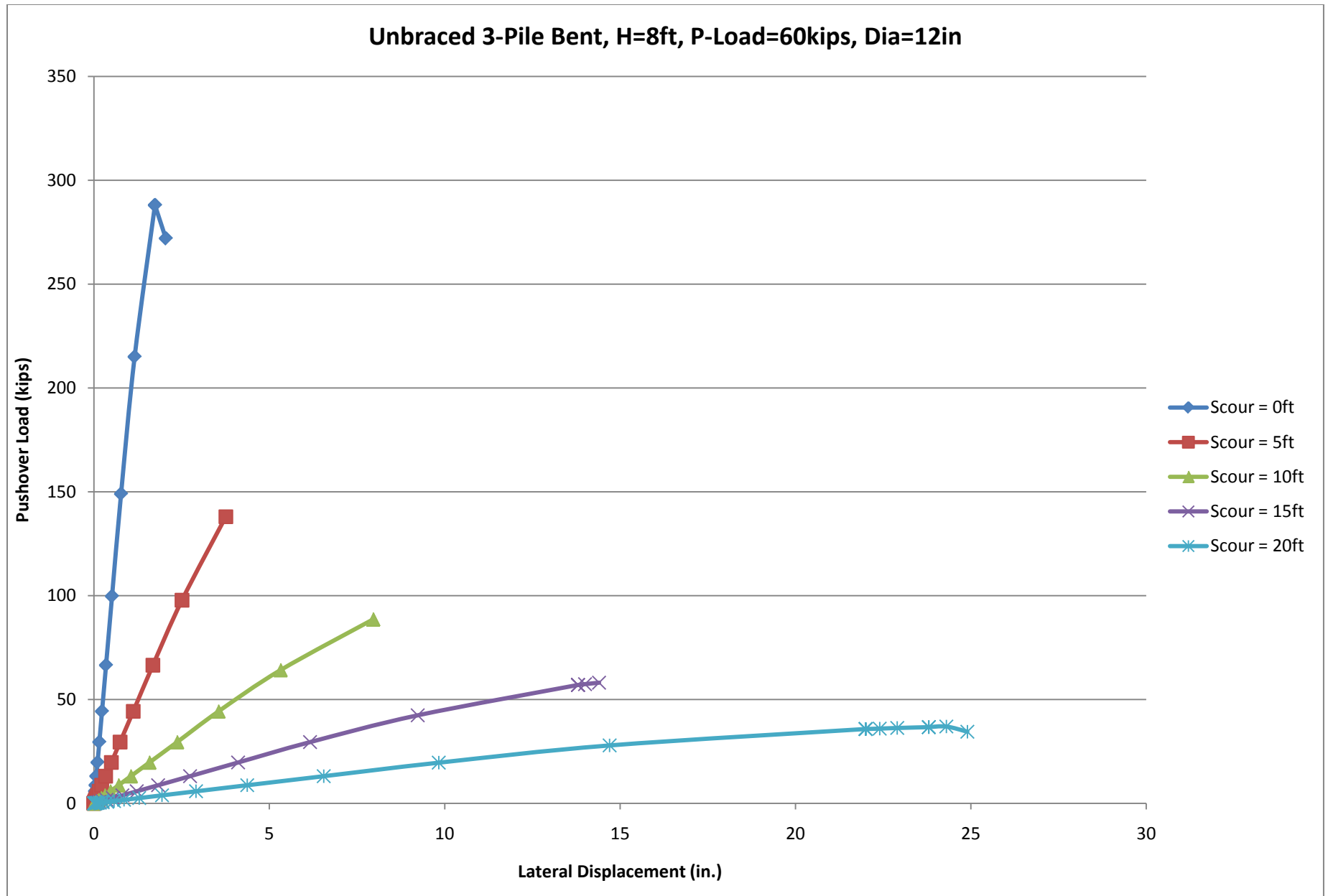


**Figure B.1 Pushover Curves for Unbraced 3-Pile Bent, H=8ft, P=20kips, Diameter=12in, Multiple Levels of Scour**

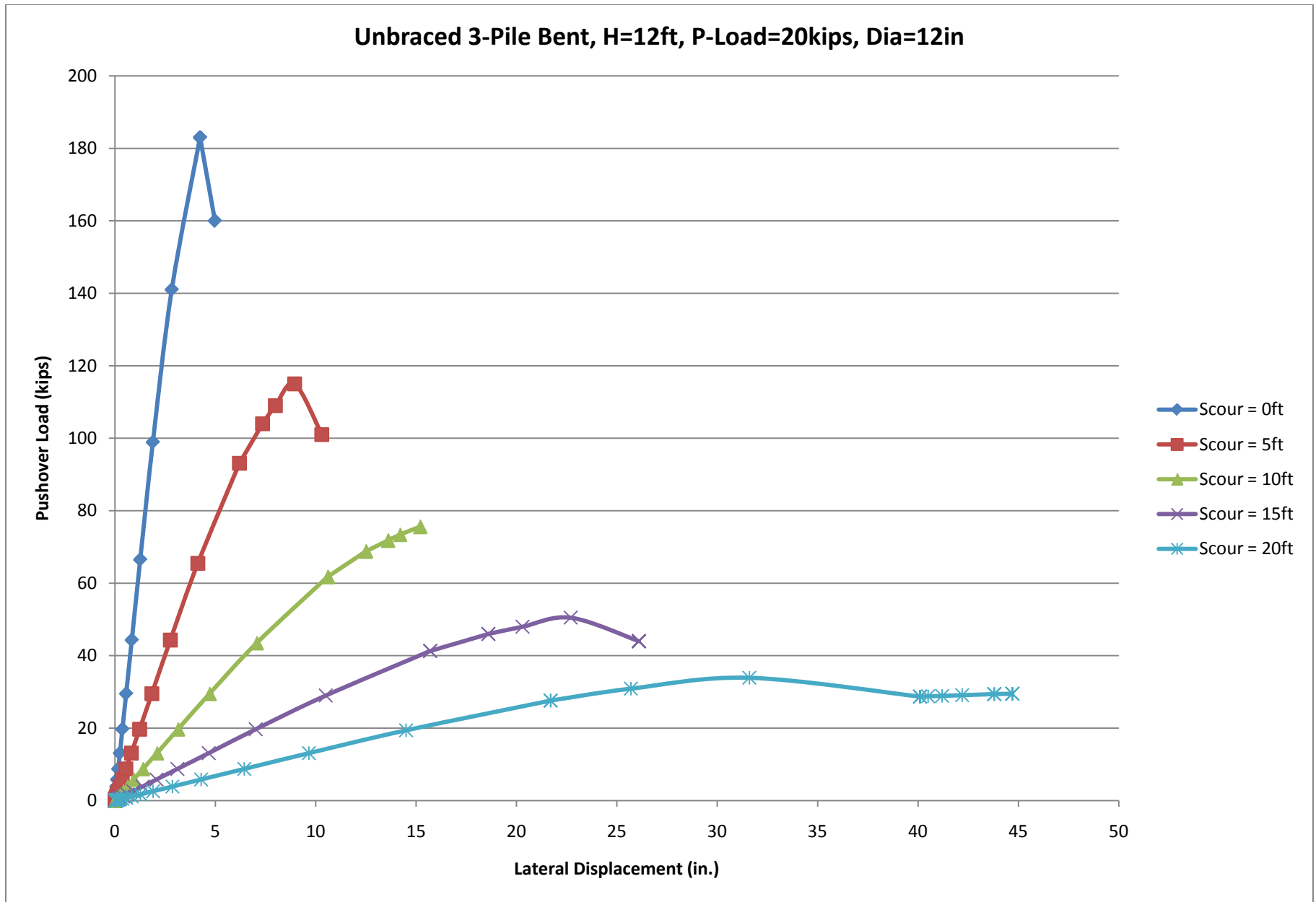




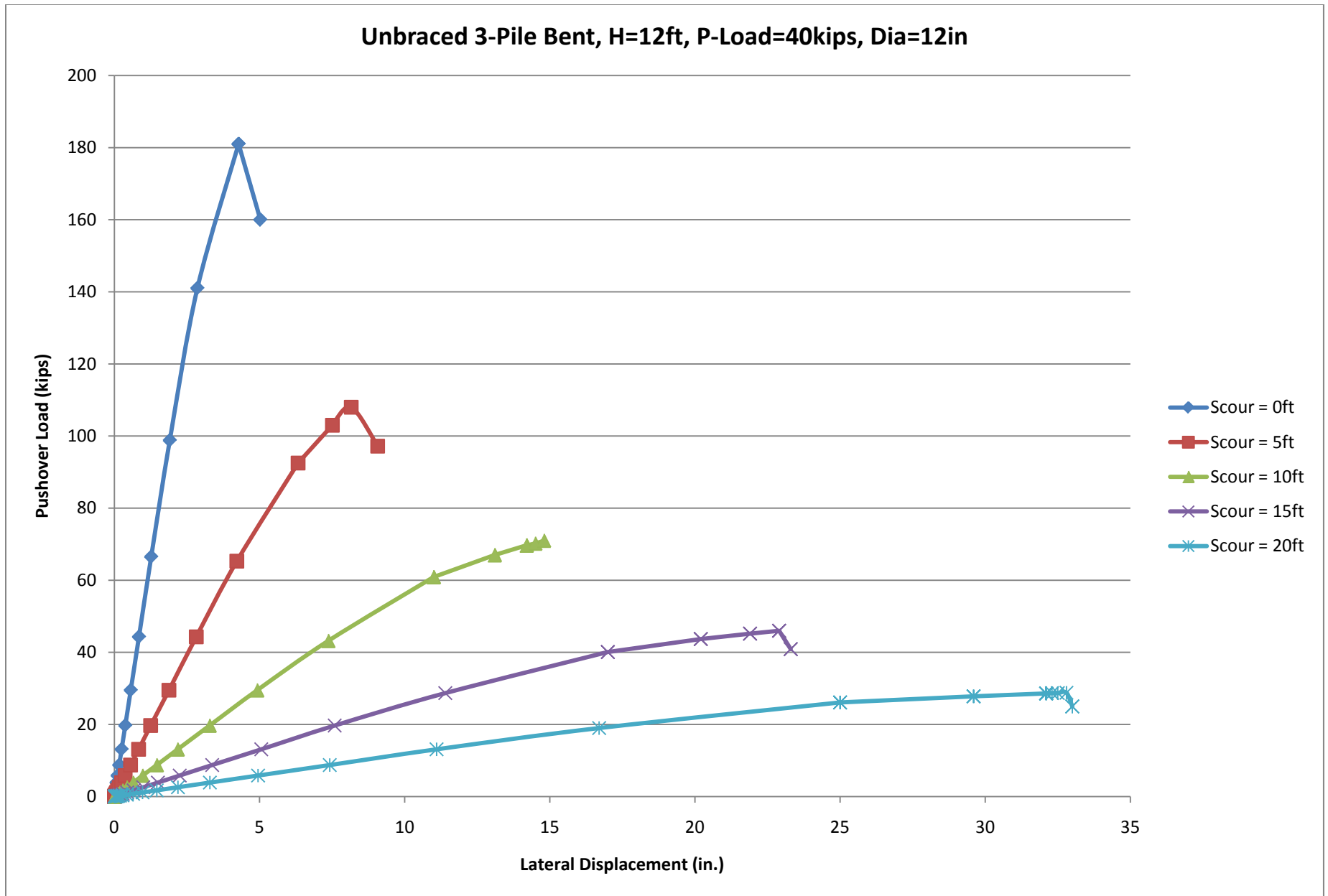
**Figure B.2 Pushover Curves for Unbraced 3-Pile Bent, H=8ft, P=40kips, Diameter=12in, Multiple Levels of Scour**



**Figure B.3 Pushover Curves for Unbraced 3-Pile Bent, H=8ft, P=60kips, Diameter=12in, Multiple Levels of Scour**



**Figure B.4 Pushover Curves for Unbraced 3-Pile Bent, H=12ft, P=20kips, Diameter=12in, Multiple Levels of Scour**



**Figure B.5 Pushover Curves for Unbraced 3-Pile Bent, H=12ft, P=40kips, Diameter=12in, Multiple Levels of Scour**

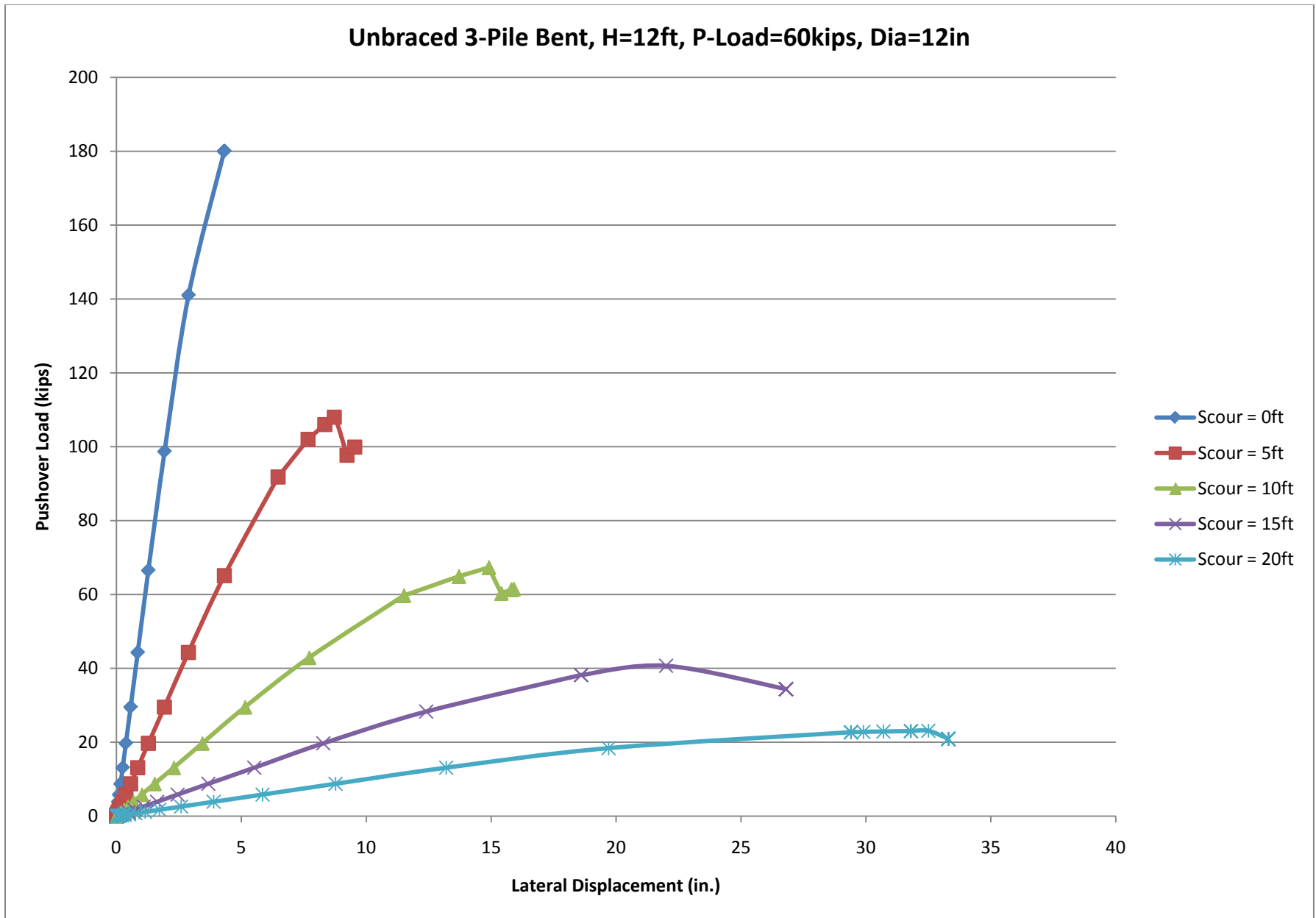


Figure B.6 Pushover Curves for Unbraced 3-Pile Bent, H=12ft, P=60kips, Diameter=12in, Multiple Levels of Scour

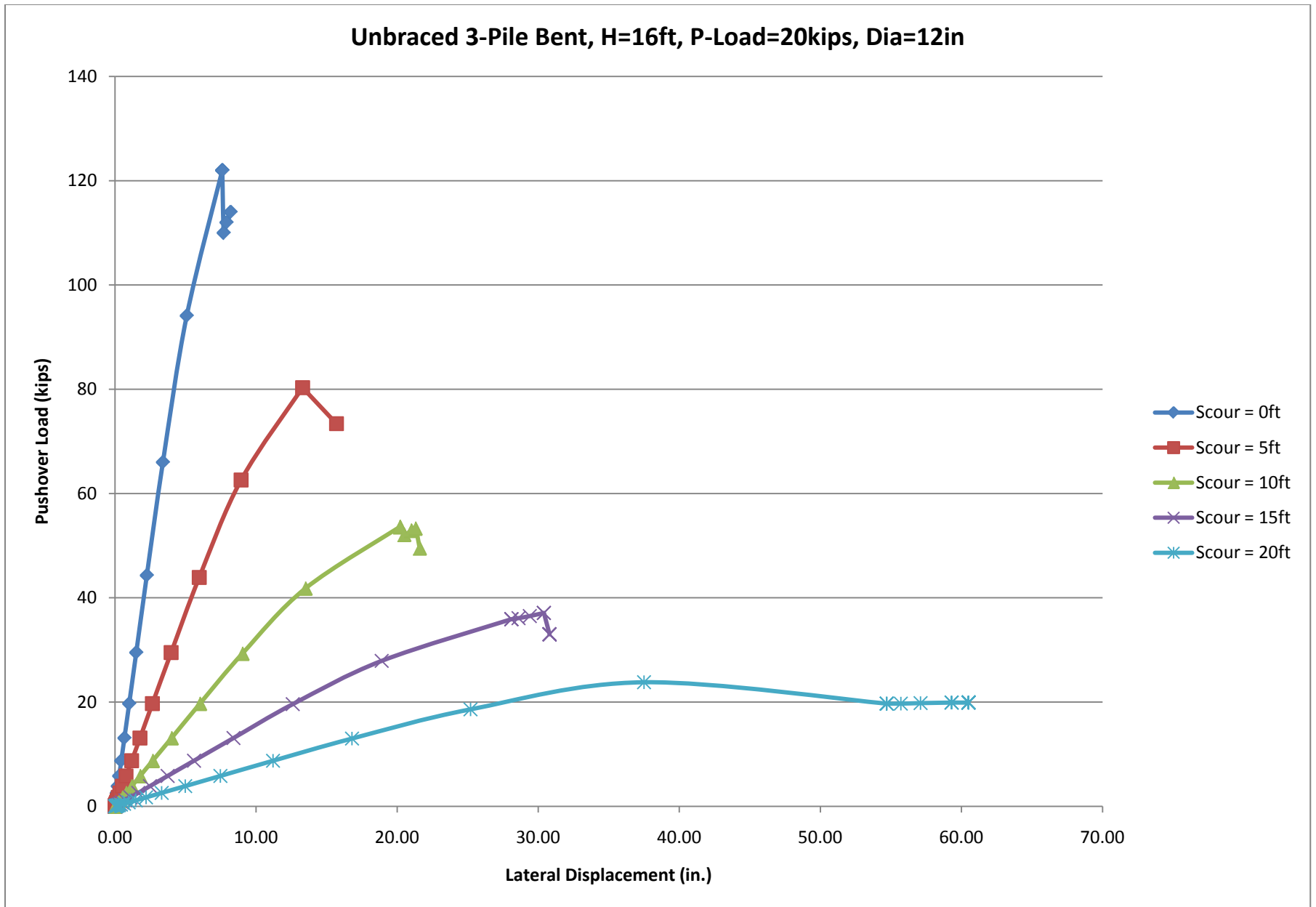


Figure B.7 Pushover Curves for Unbraced 3-Pile Bent, H=16ft, P=20kips, Diameter=12in, Multiple Levels of Scour

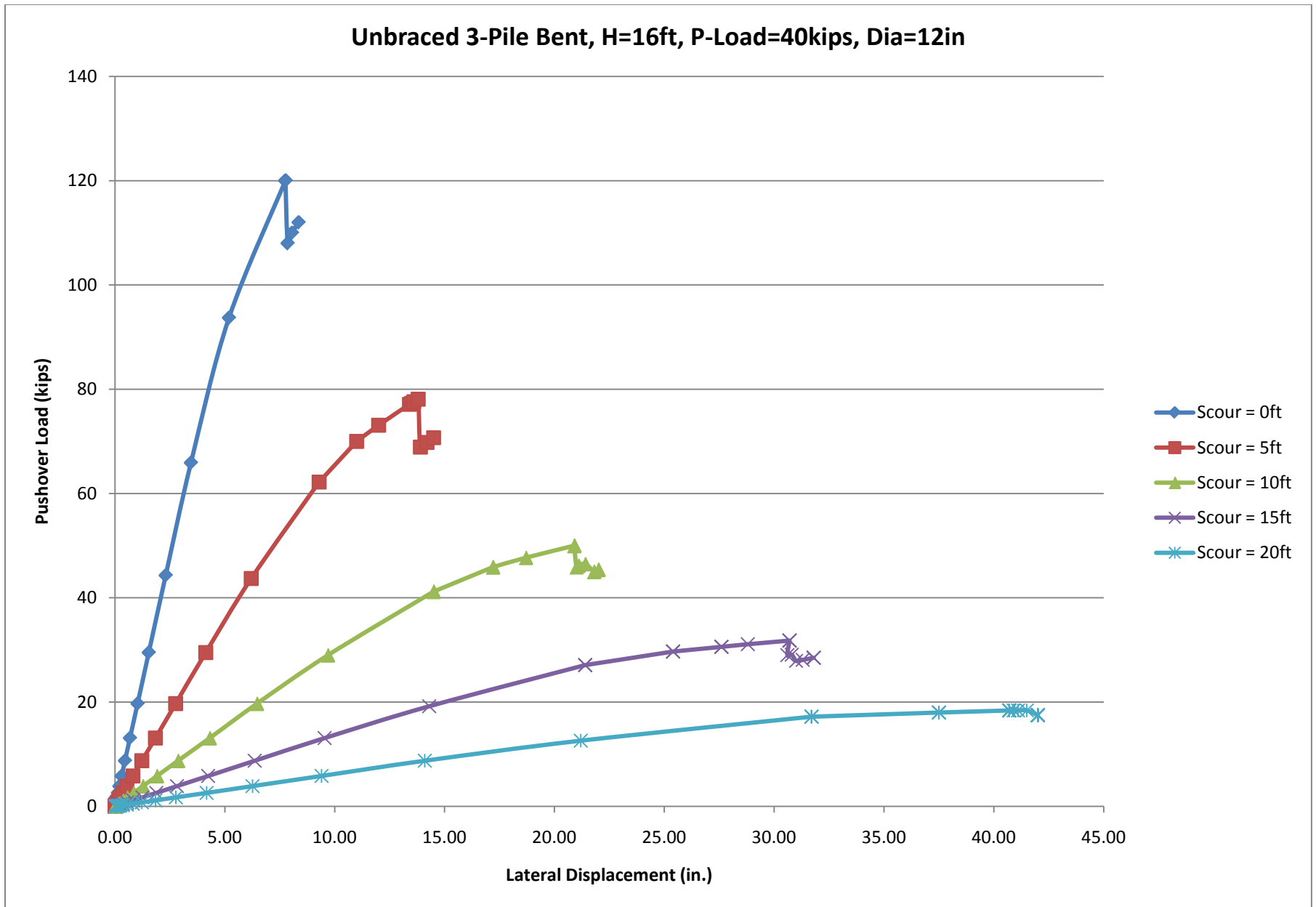
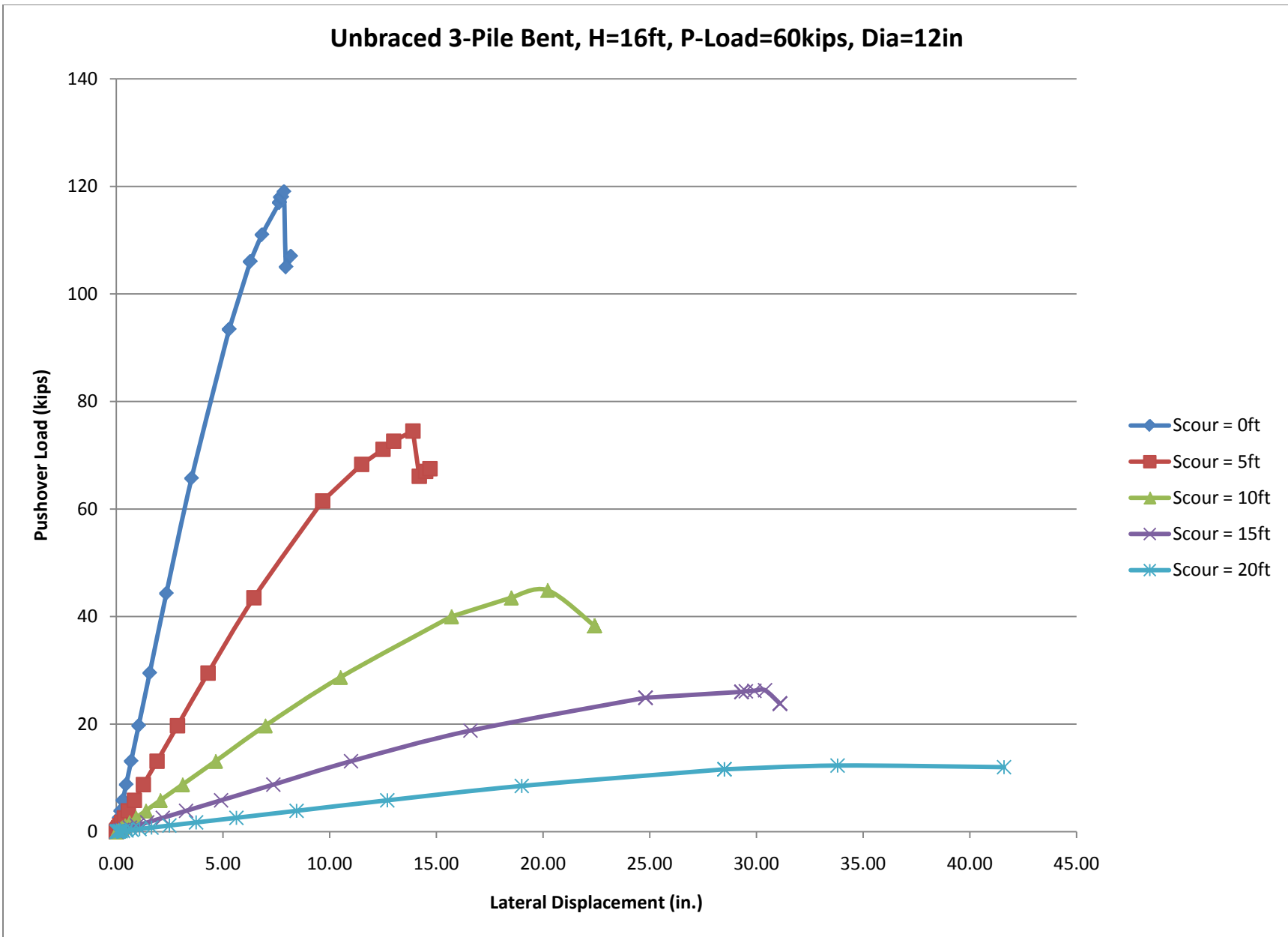
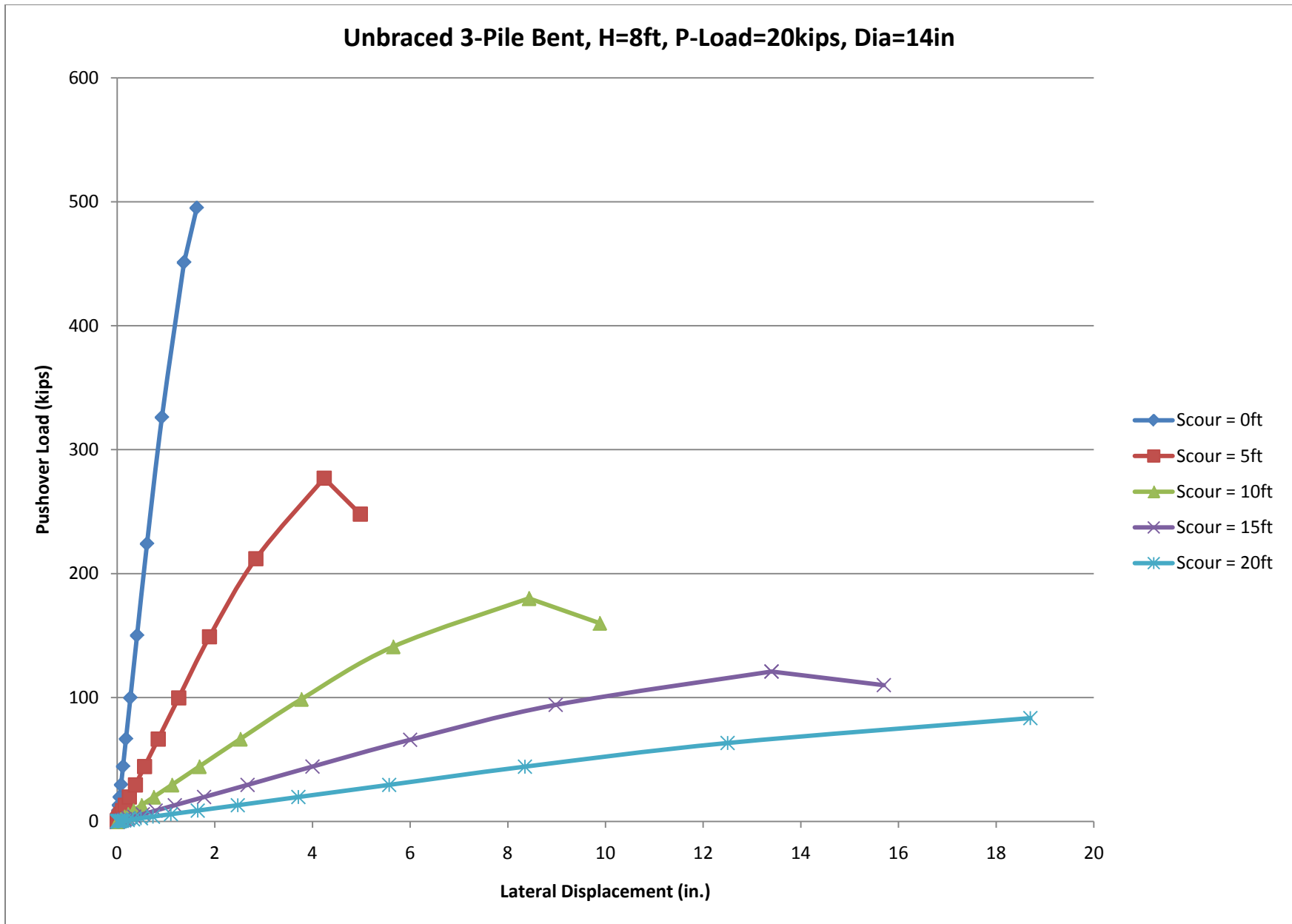


Figure B.8 Pushover Curves for Unbraced 3-Pile Bent, H=16ft, P=40kips, Diameter=12in, Multiple Levels of Scour



**Figure B.9 Pushover Curves for Unbraced 3-Pile Bent, H=16ft, P=60kips, Diameter=12in, Multiple Levels of Scour**





**Figure B.10 Pushover Curves for Unbraced 3-Pile Bent, H=8ft, P=20kips, Diameter=14in, Multiple Levels of Scour**

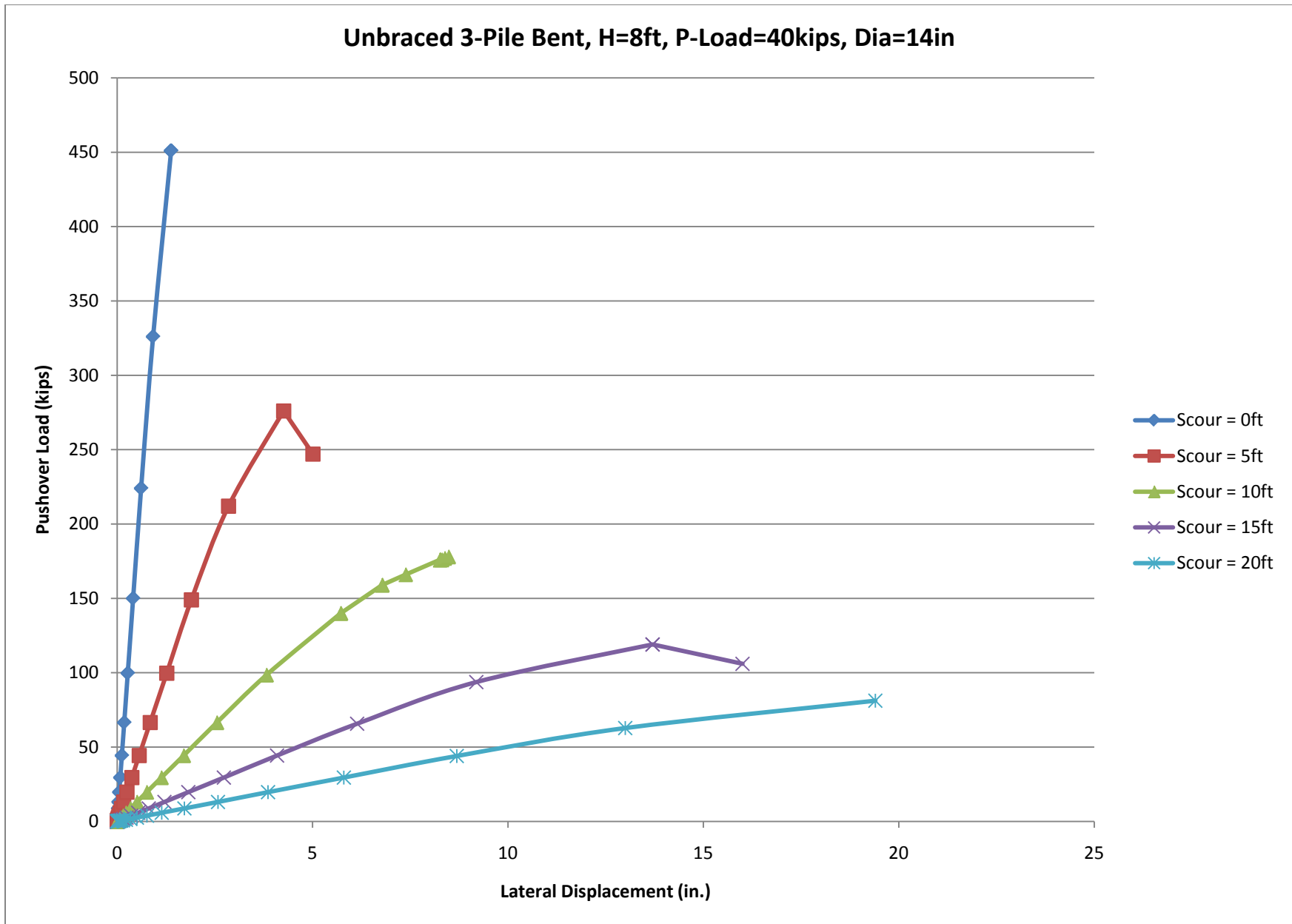


Figure B.11 Pushover Curves for Unbraced 3-Pile Bent, H=8ft, P=40kips, Diameter=14in, Multiple Levels of Scour

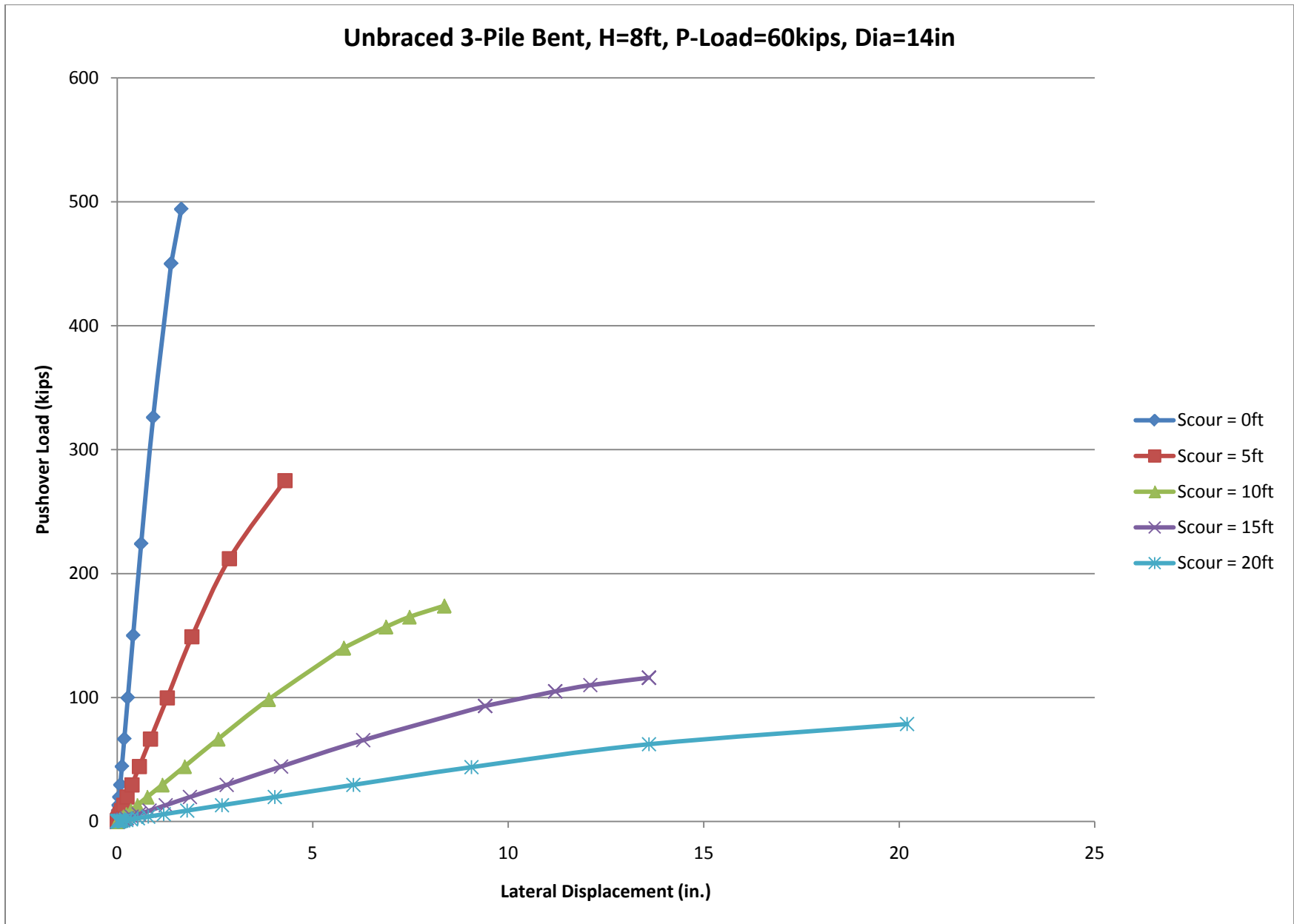
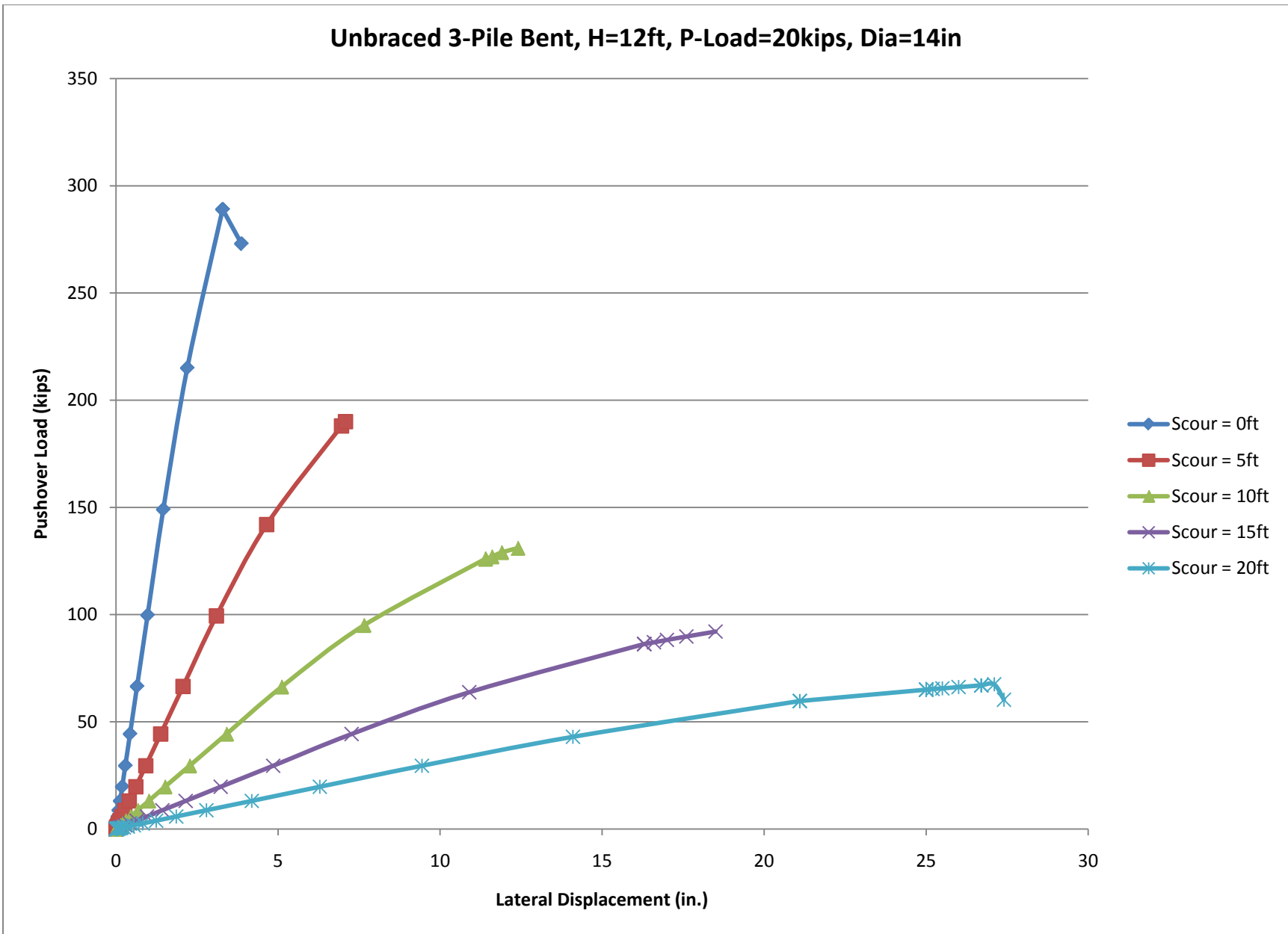
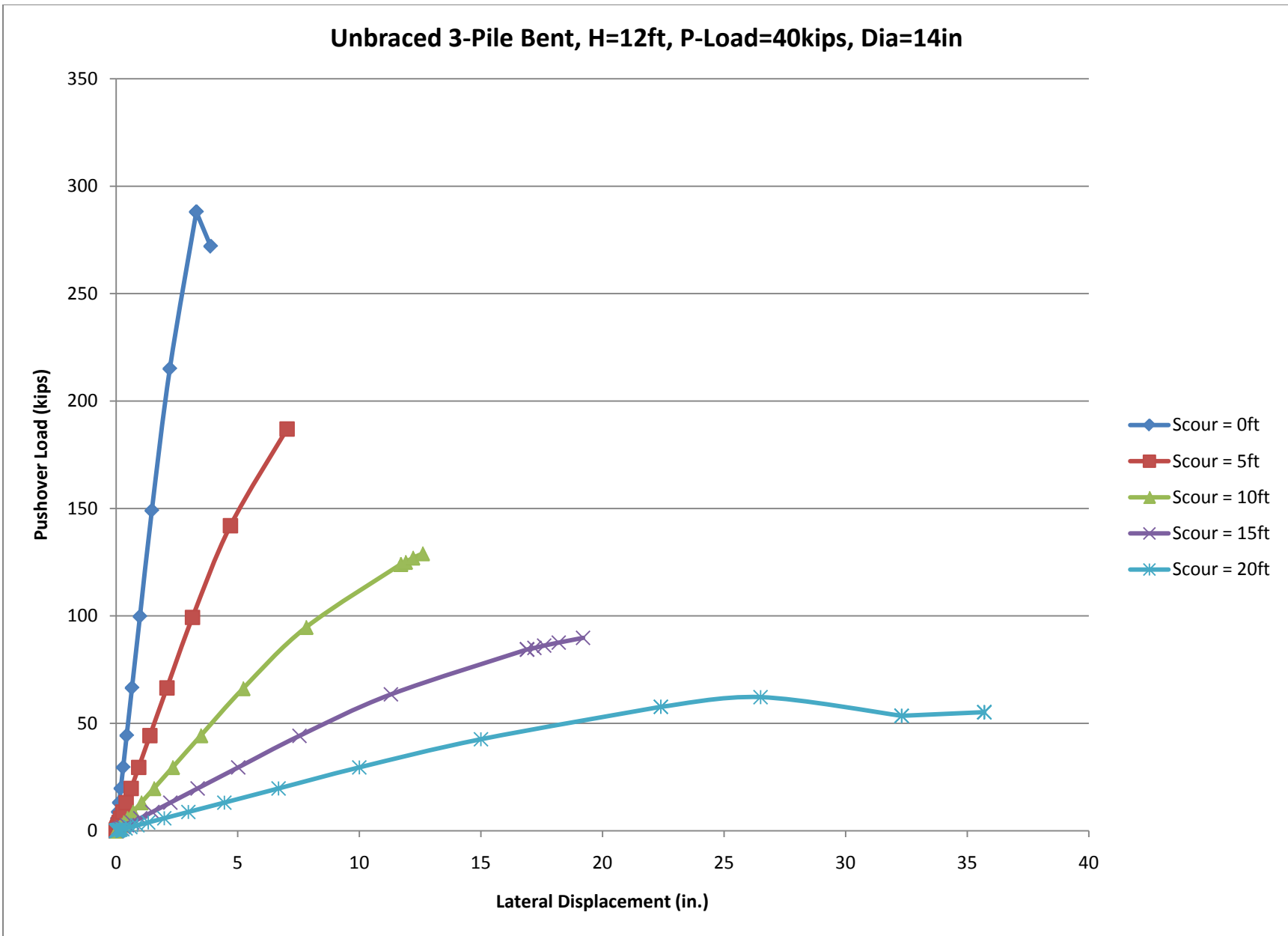


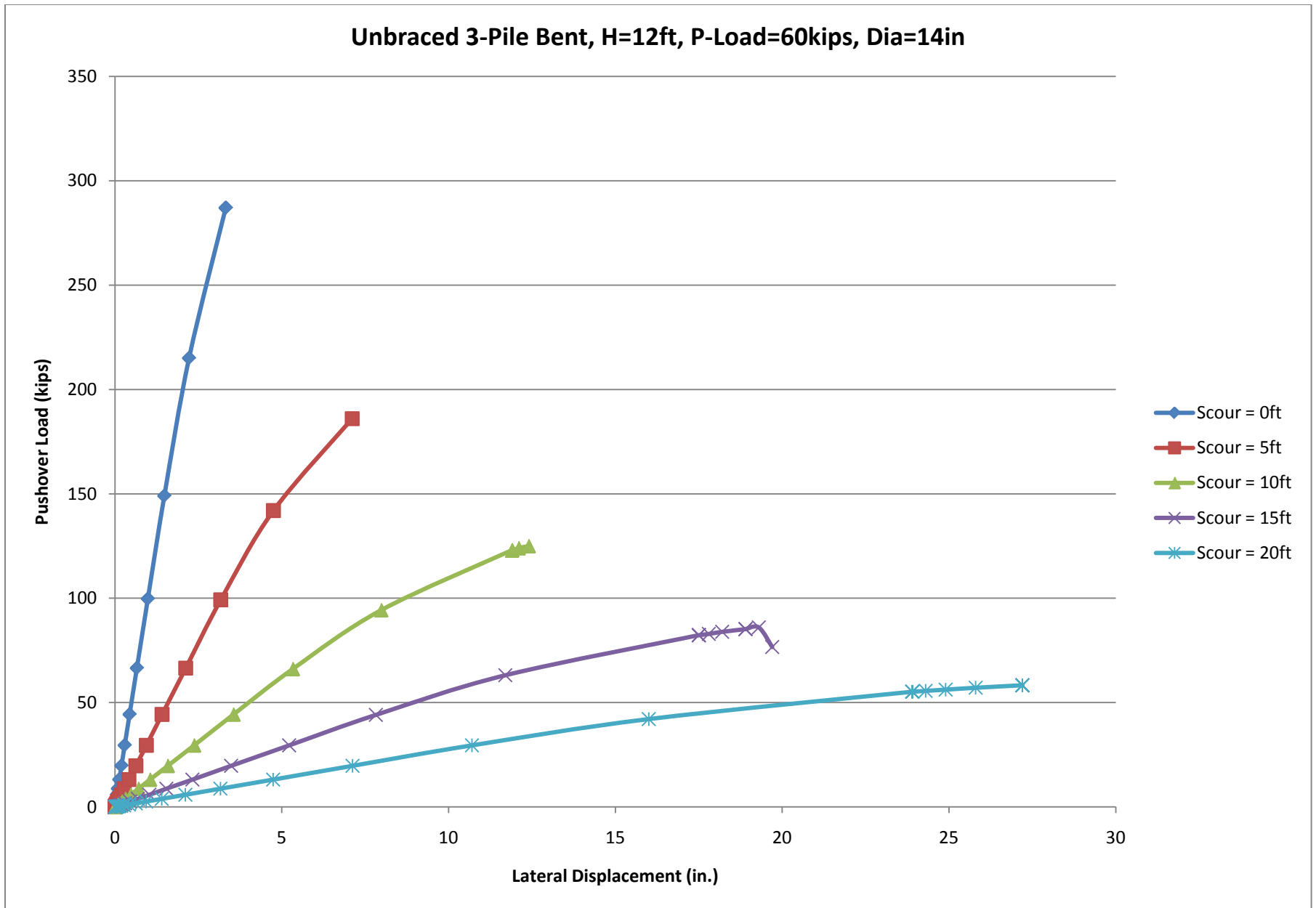
Figure B.12 Pushover Curves for Unbraced 3-Pile Bent, H=8ft, P=60kips, Diameter=14in, Multiple Levels of Scour



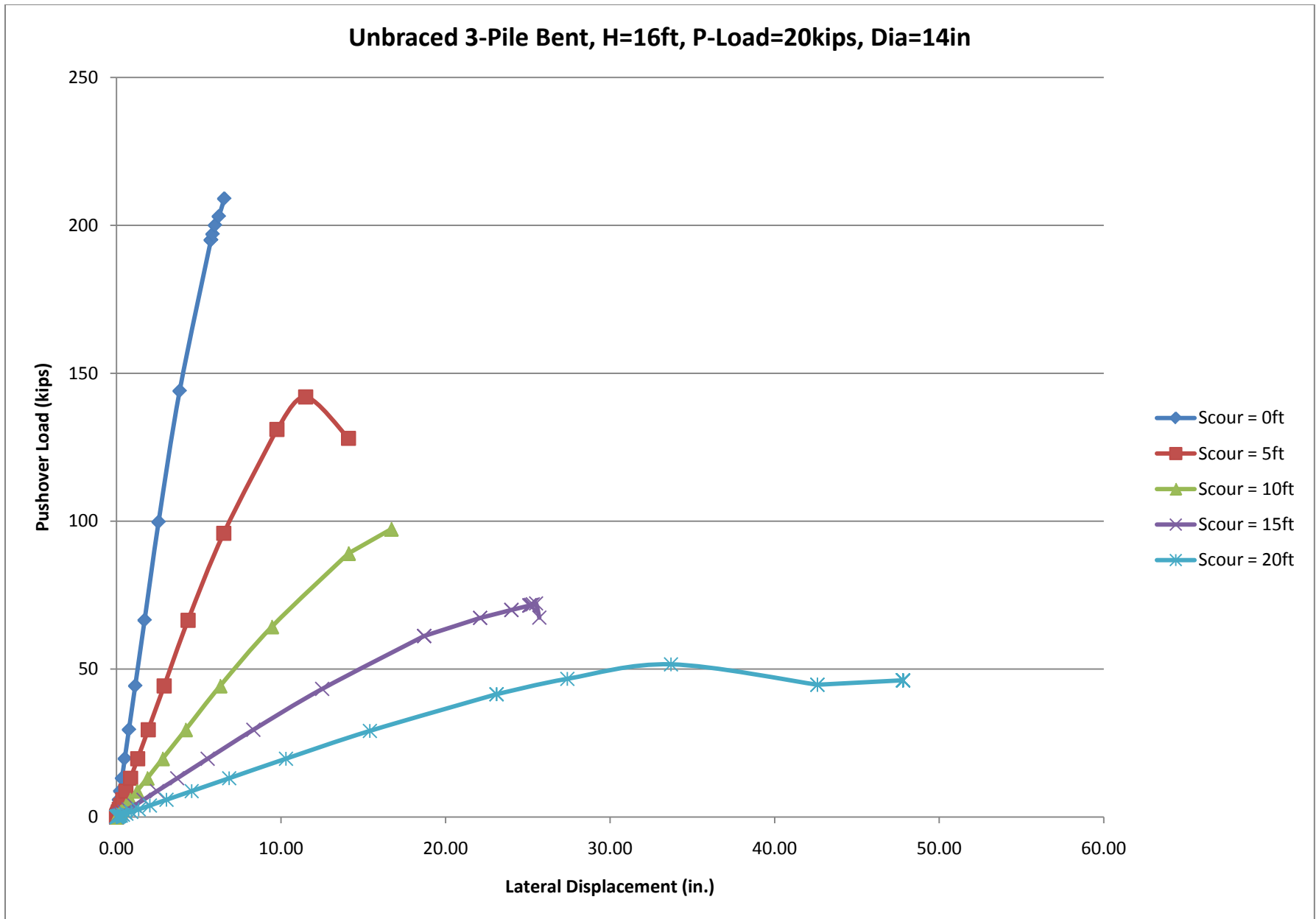
**Figure B.13 Pushover Curves for Unbraced 3-Pile Bent, H=12ft, P=20kips, Diameter=14in, Multiple Levels of Scour**



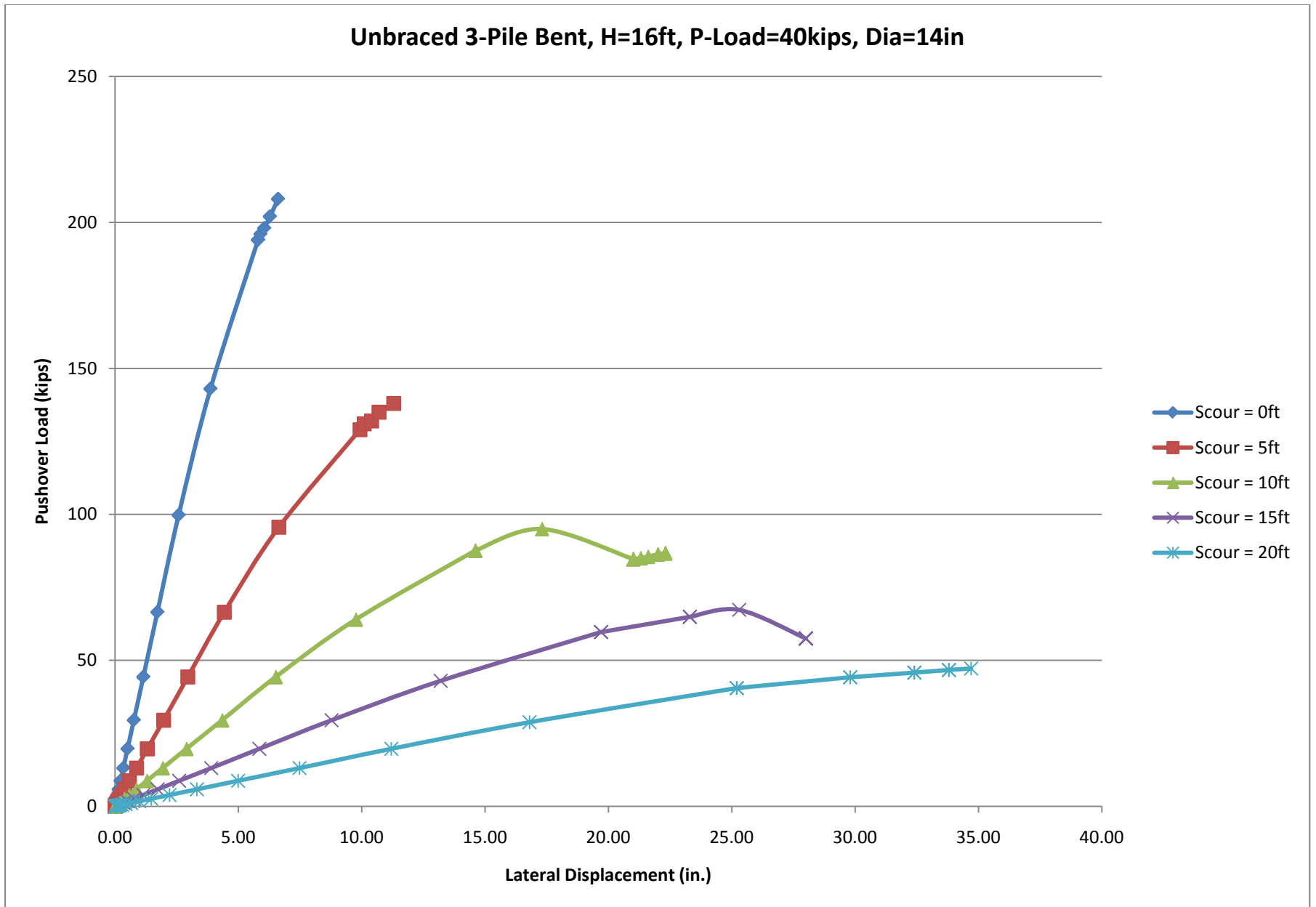
**Figure B.14 Pushover Curves for Unbraced 3-Pile Bent, H=12ft, P=40kips, Diameter=14in, Multiple Levels of Scour**



**Figure B.15 Pushover Curves for Unbraced 3-Pile Bent, H=12ft, P=60kips, Diameter=14in, Multiple Levels of Scour**



**Figure B.16 Pushover Curves for Unbraced 3-Pile Bent, H=16ft, P=20kips, Diameter=14in, Multiple Levels of Scour**



**Figure B.17 Pushover Curves for Unbraced 3-Pile Bent, H=16ft, P=40kips, Diameter=14in, Multiple Levels of Scour**



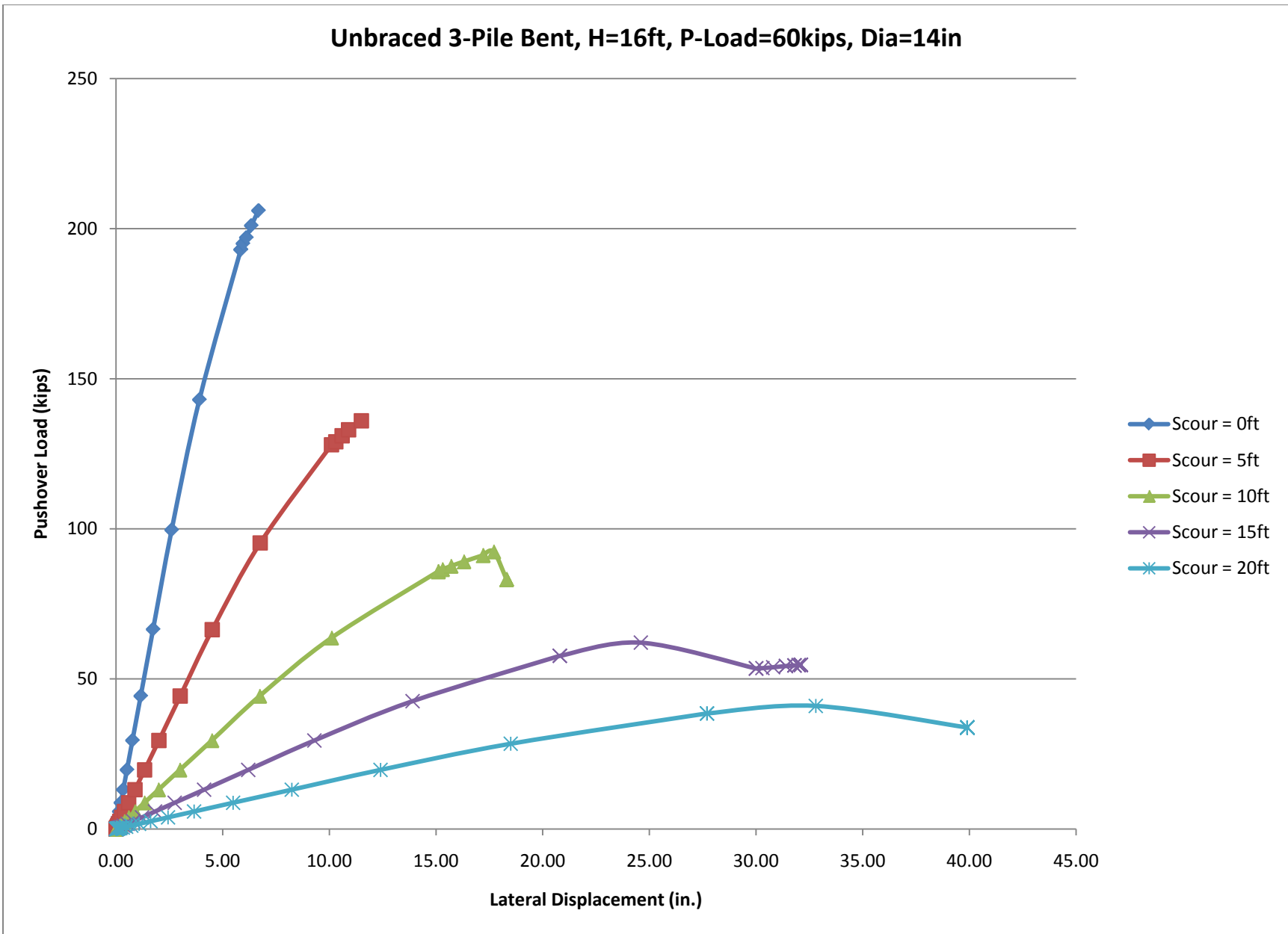


Figure B.18 Pushover Curves for Unbraced 3-Pile Bent, H=16ft, P=60kips, Diameter=14in, Multiple Levels of Scour

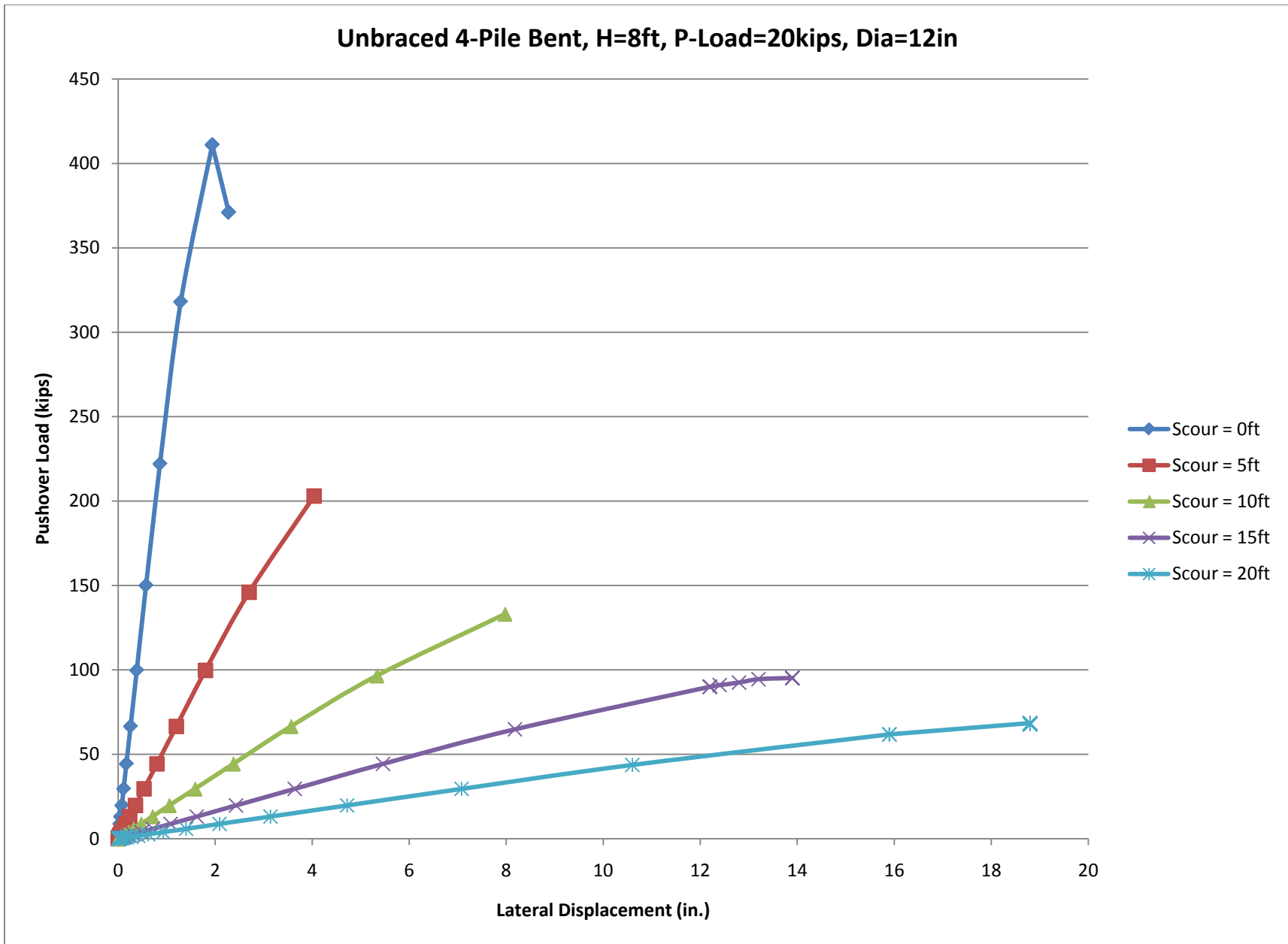


Figure B.18 Pushover Curves for Unbraced 4-Pile Bent, H=8ft, P=20kips, Diameter=12in, Multiple Levels of Scour

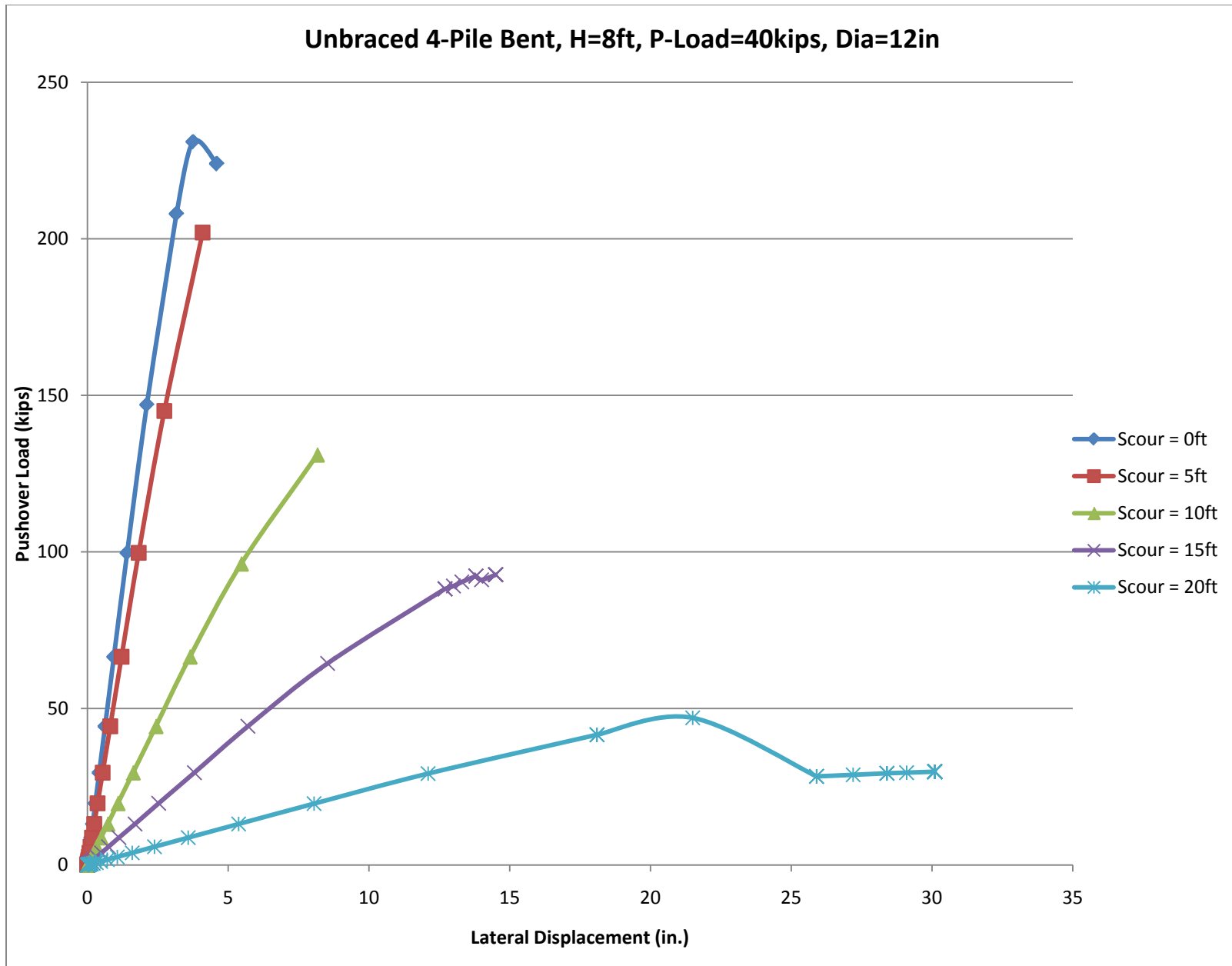


Figure B.19 Pushover Curves for Unbraced 4-Pile Bent, H=8ft, P=40kips, Diameter=12in, Multiple Levels of Scour

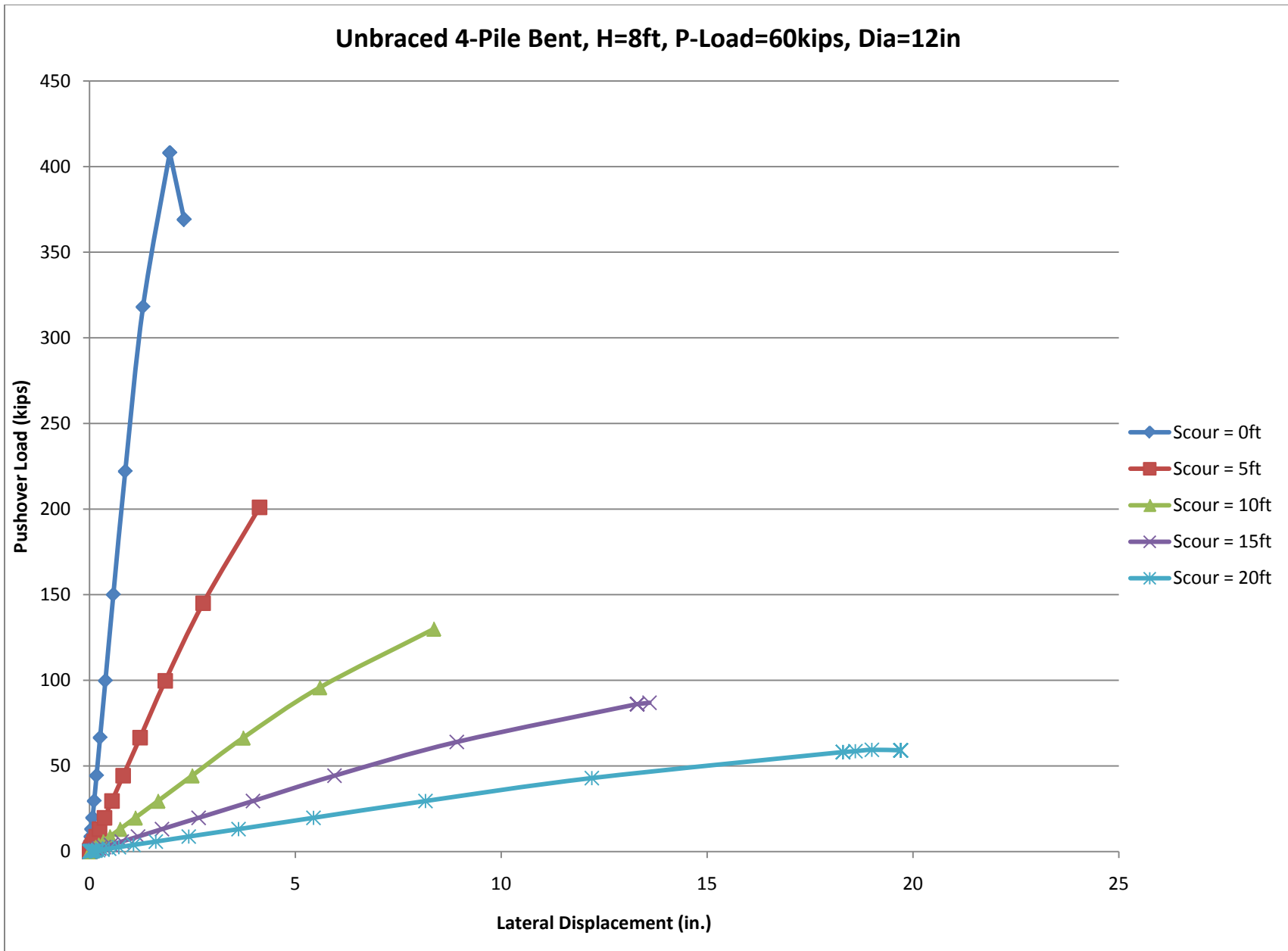


Figure B.21 Pushover Curves for Unbraced 4-Pile Bent, H=8ft, P=60kips, Diameter=12in, Multiple Levels of Scour

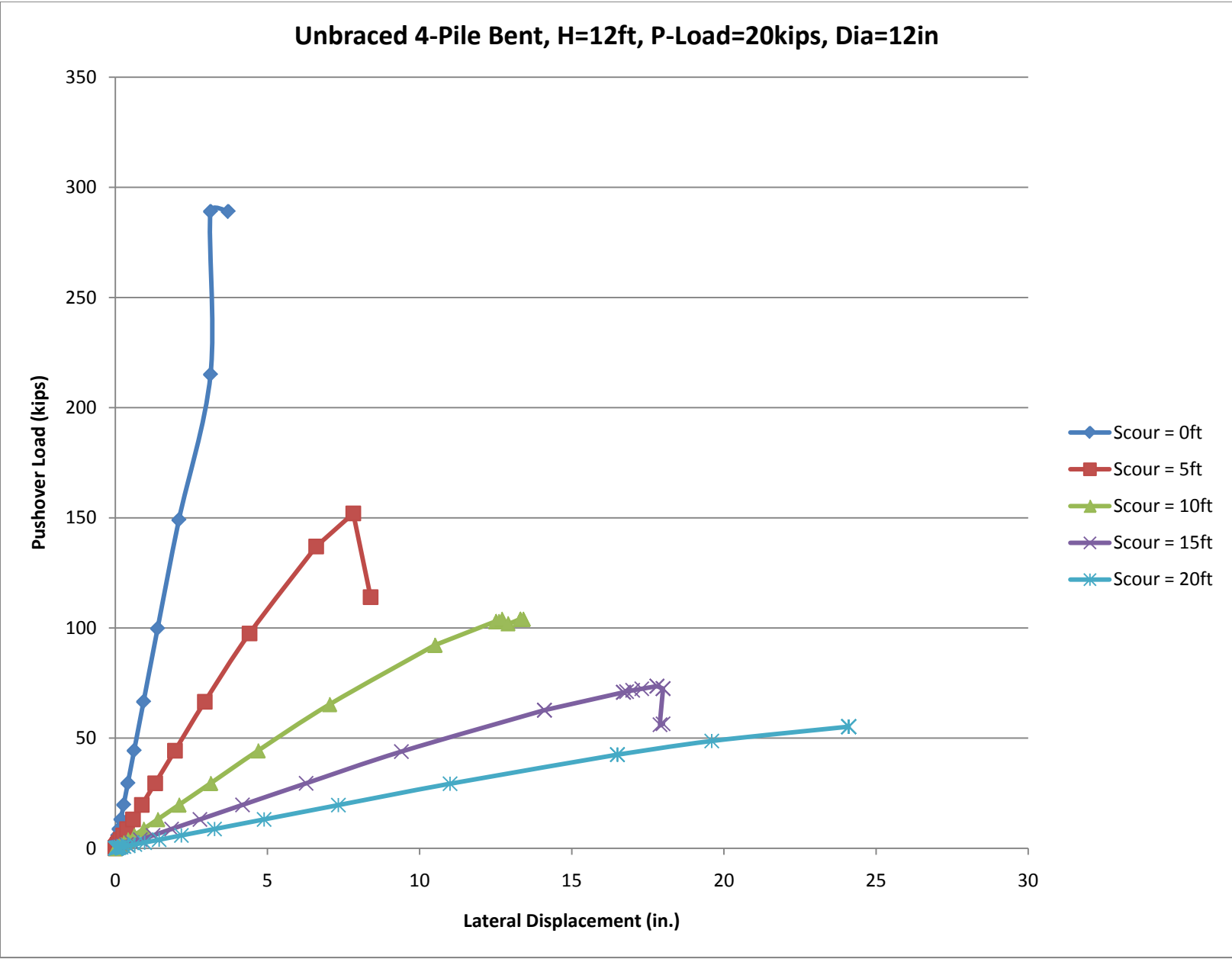


Figure B.22 Pushover Curves for Unbraced 4-Pile Bent, H=12ft, P=20kips, Diameter=12in, Multiple Levels of Scour

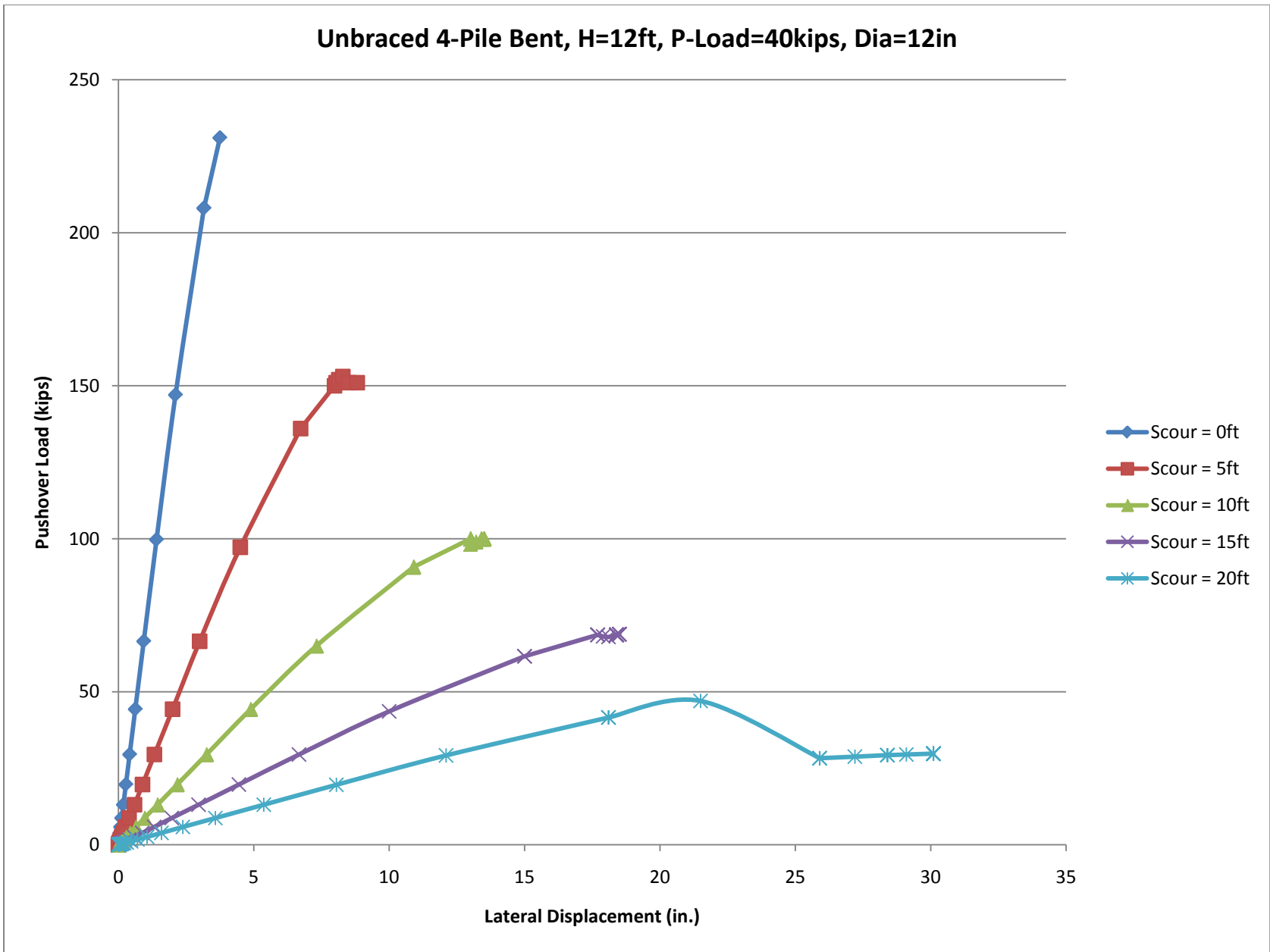


Figure B.23 Pushover Curves for Unbraced 4-Pile Bent, H=12ft, P=40kips, Diameter=12in, Multiple Levels of Scour

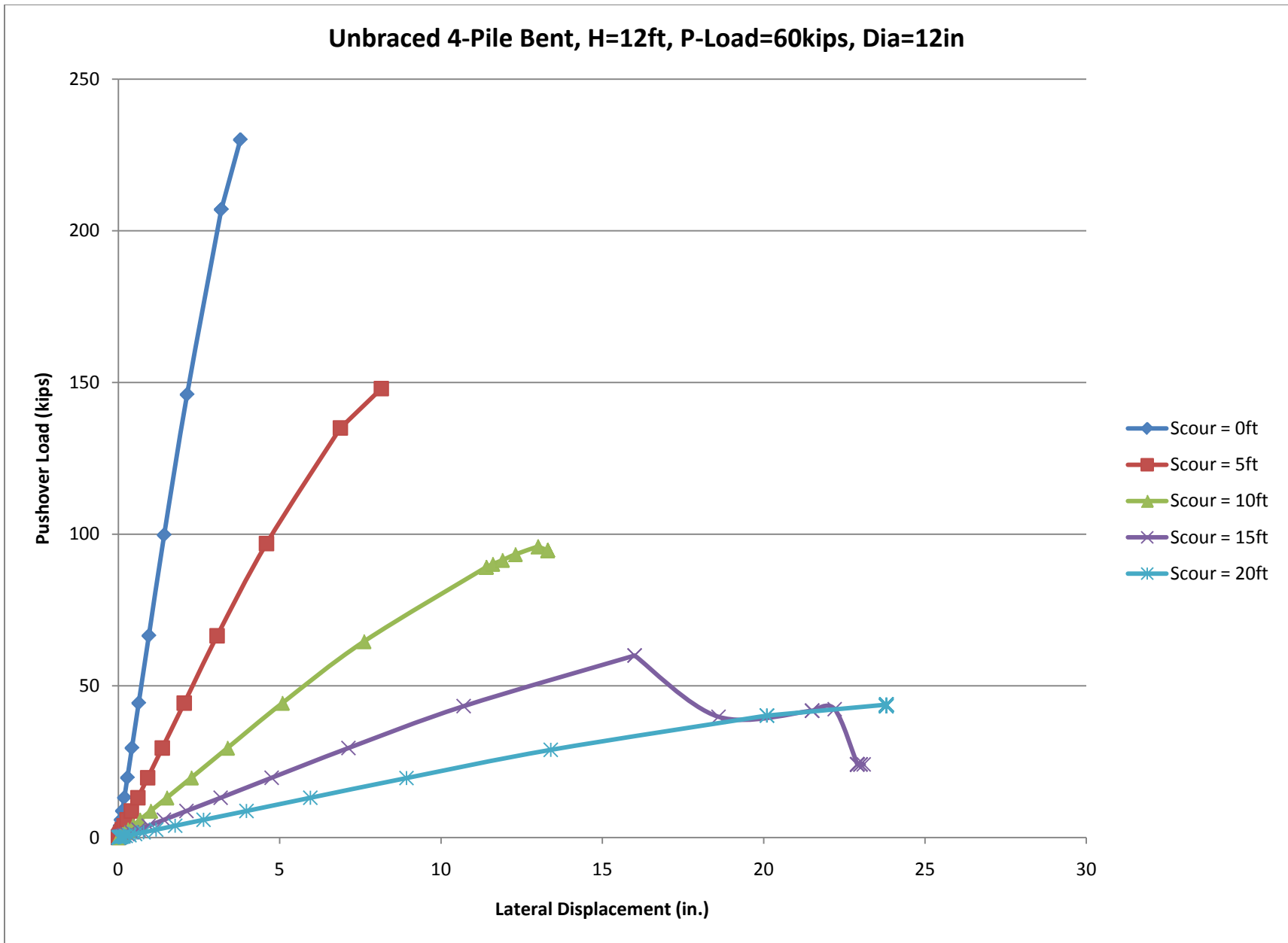


Figure B.24 Pushover Curves for Unbraced 4-Pile Bent, H=12ft, P=60kips, Diameter=12in, Multiple Levels of Scour

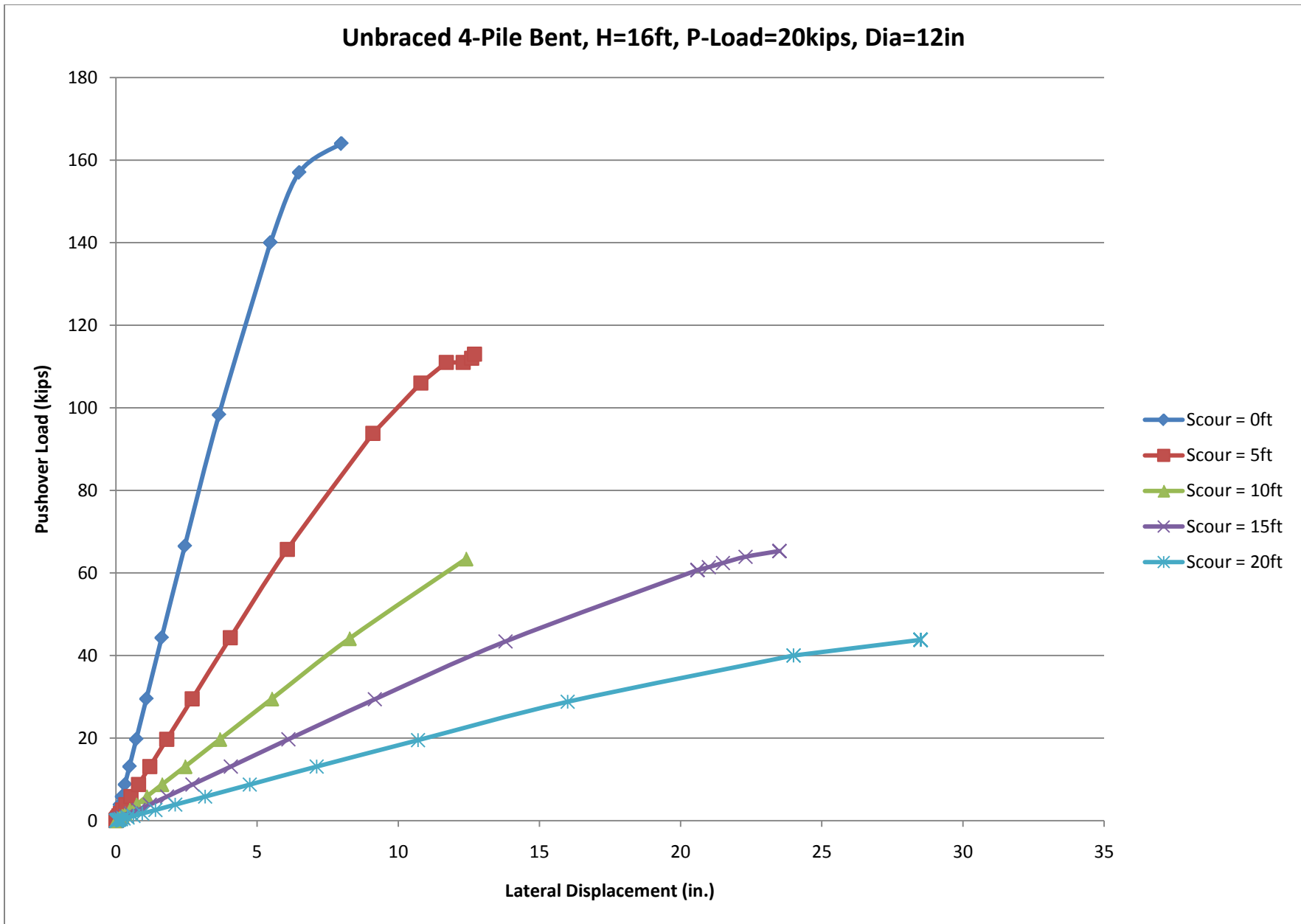
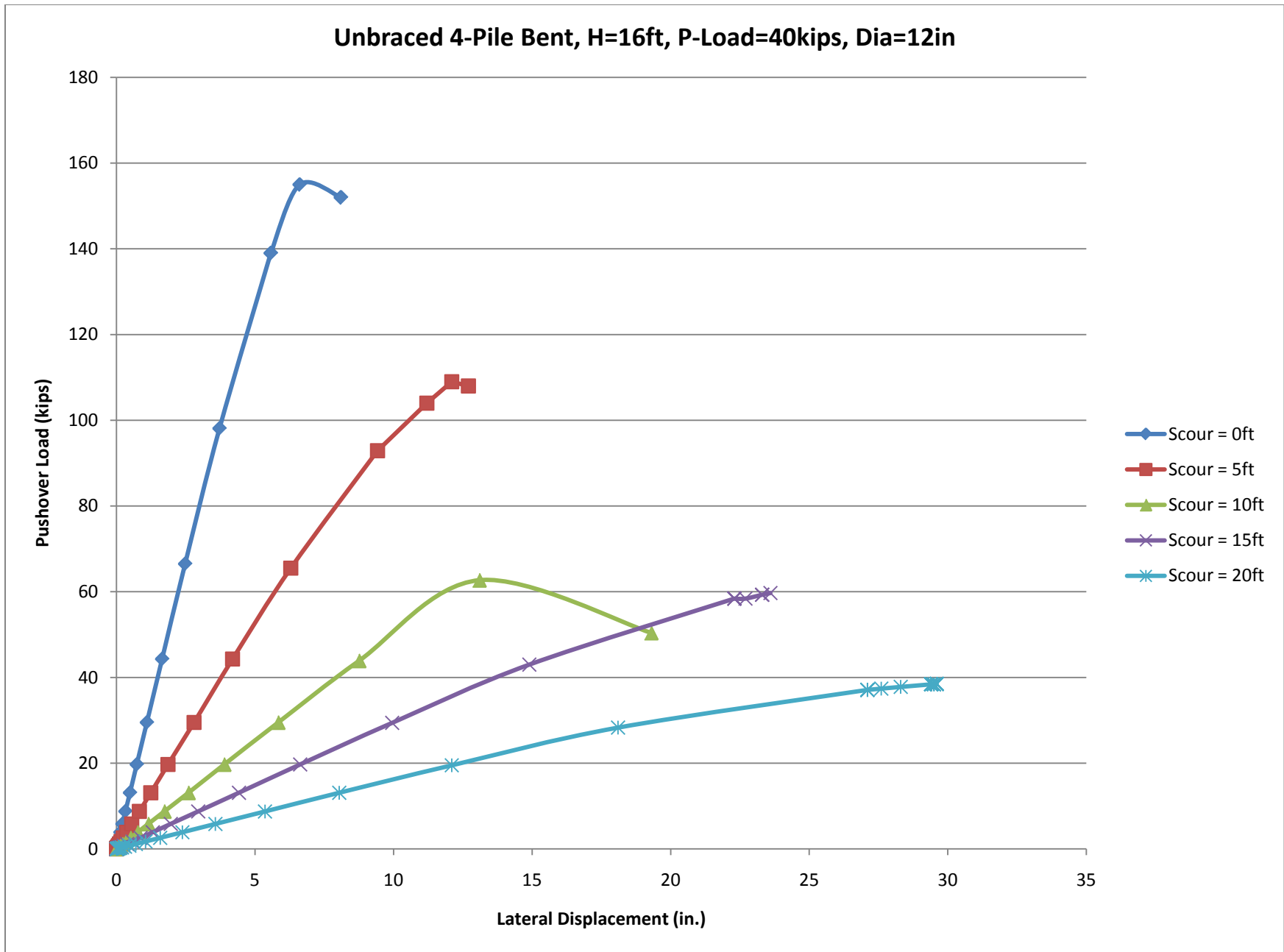
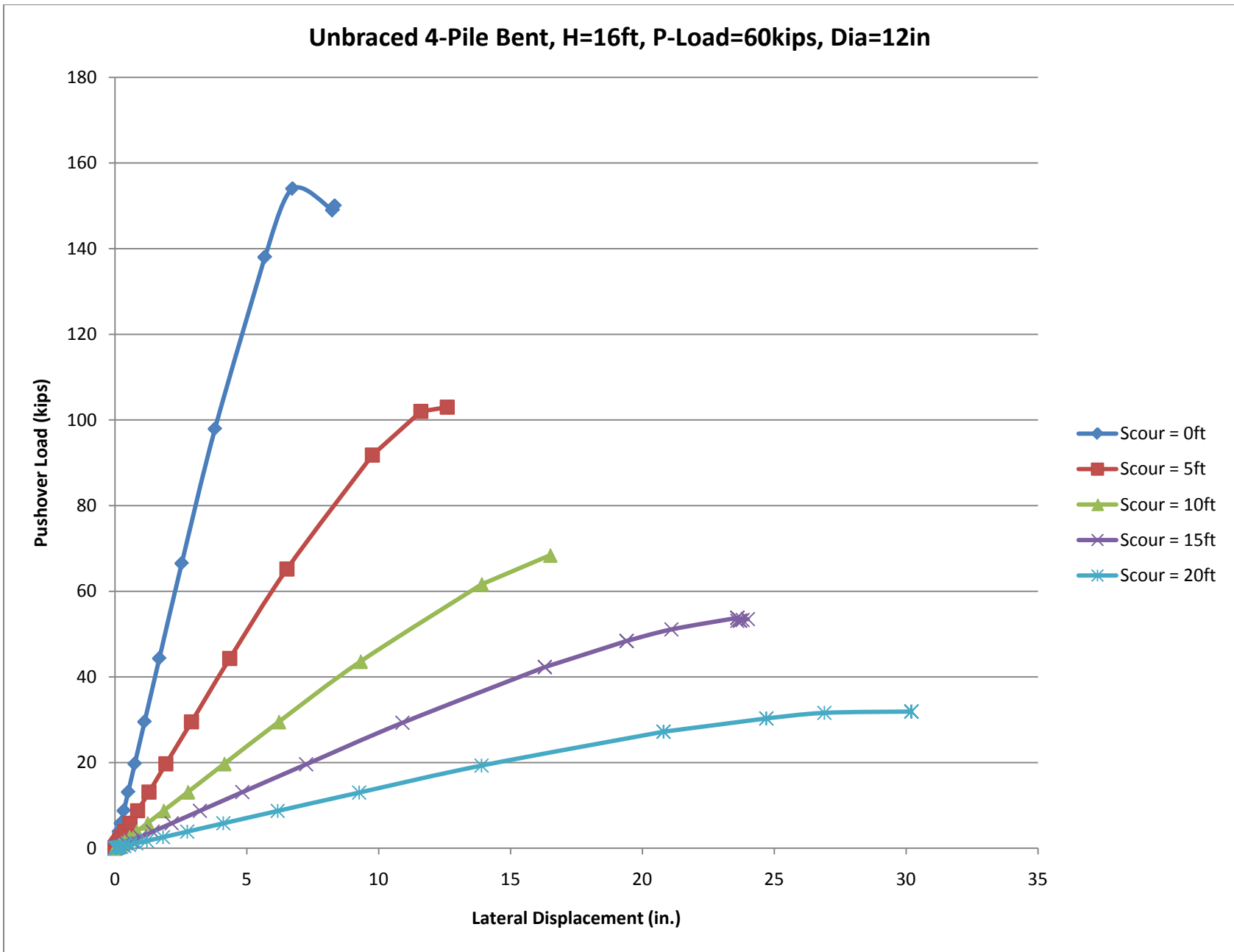


Figure B.25 Pushover Curves for Unbraced 4-Pile Bent, H=16ft, P=20kips, Diameter=12in, Multiple Levels of Scour

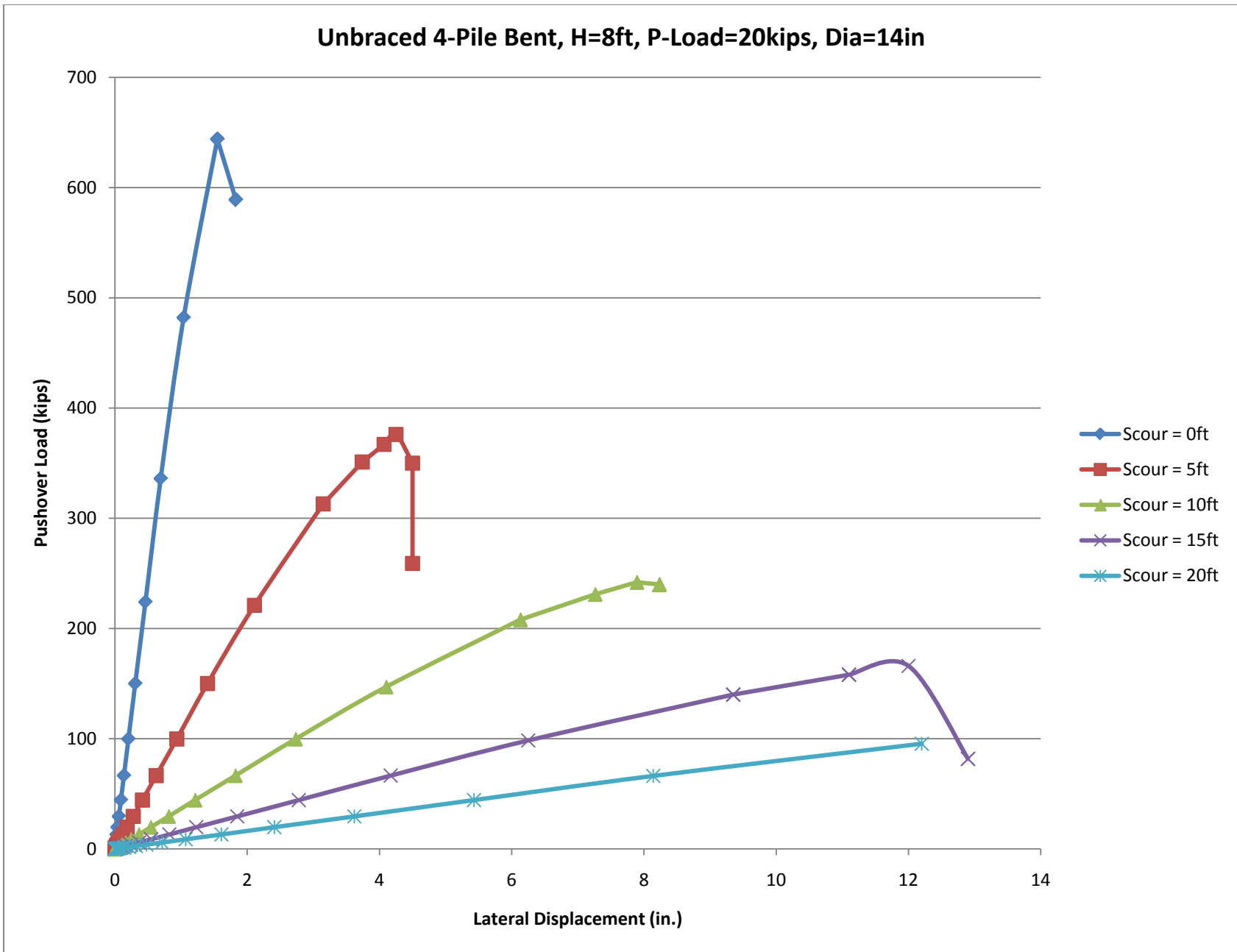




**Figure B.26 Pushover Curves for Unbraced 4-Pile Bent, H=16ft, P=40kips, Diameter=12in, Multiple Levels of Scour**  
250



**Figure B.27 Pushover Curves for Unbraced 4-Pile Bent, H=16ft, P=60kips, Diameter=12in, Multiple Levels of Scour**



**Figure B.28 Pushover Curves for Unbraced 4-Pile Bent, H=8ft, P=20kips, Diameter=14in, Multiple Levels of Scour**  
252

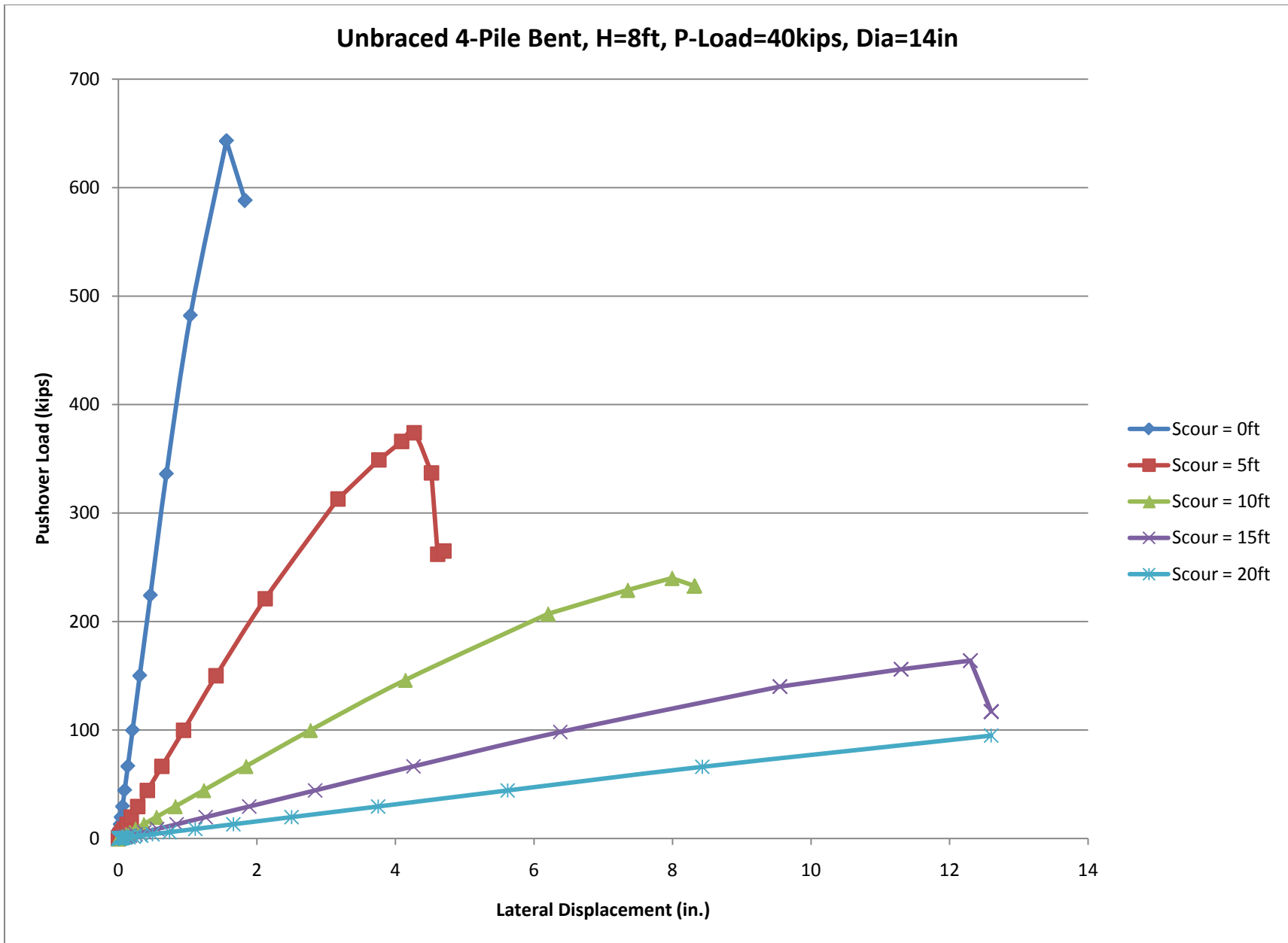
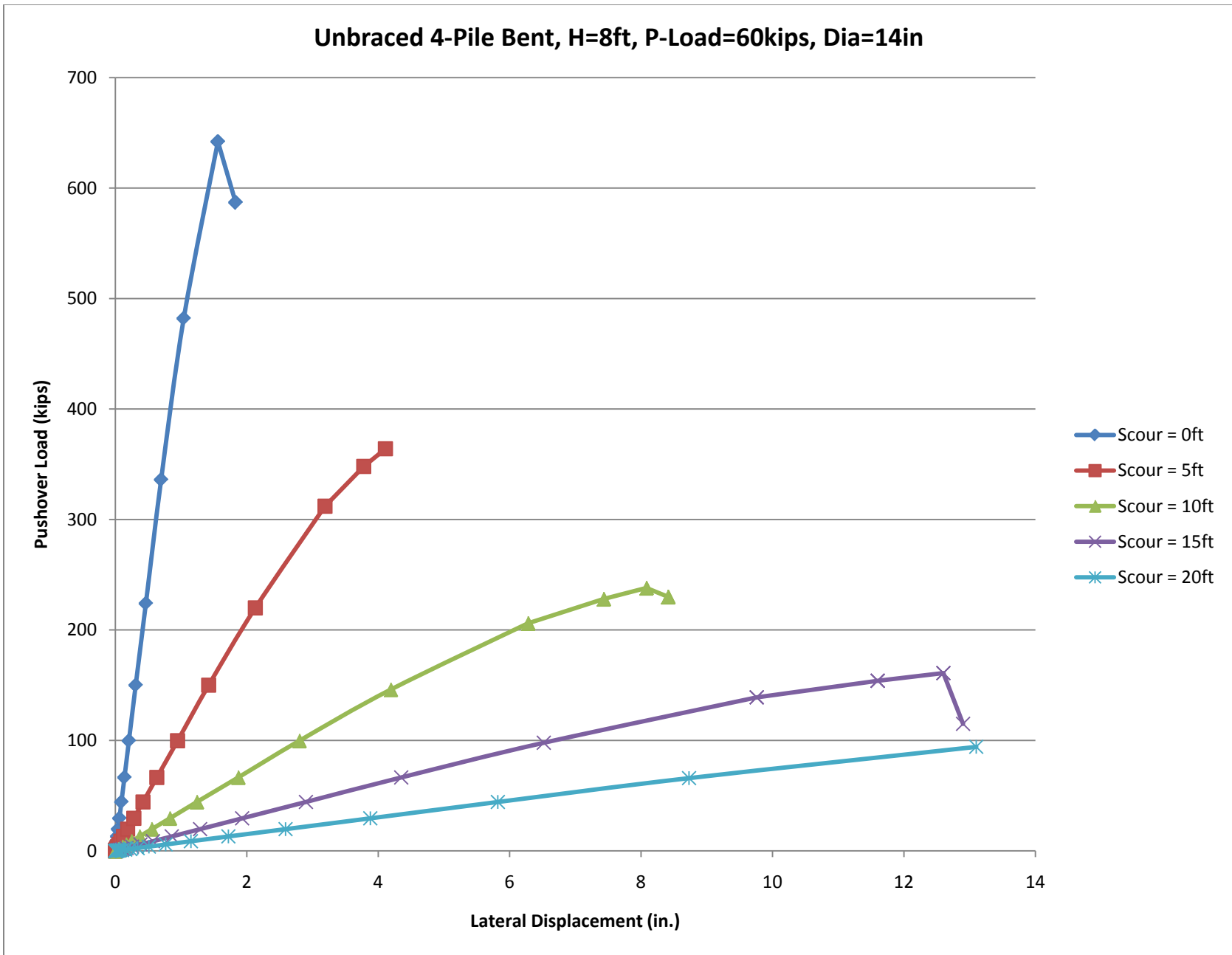
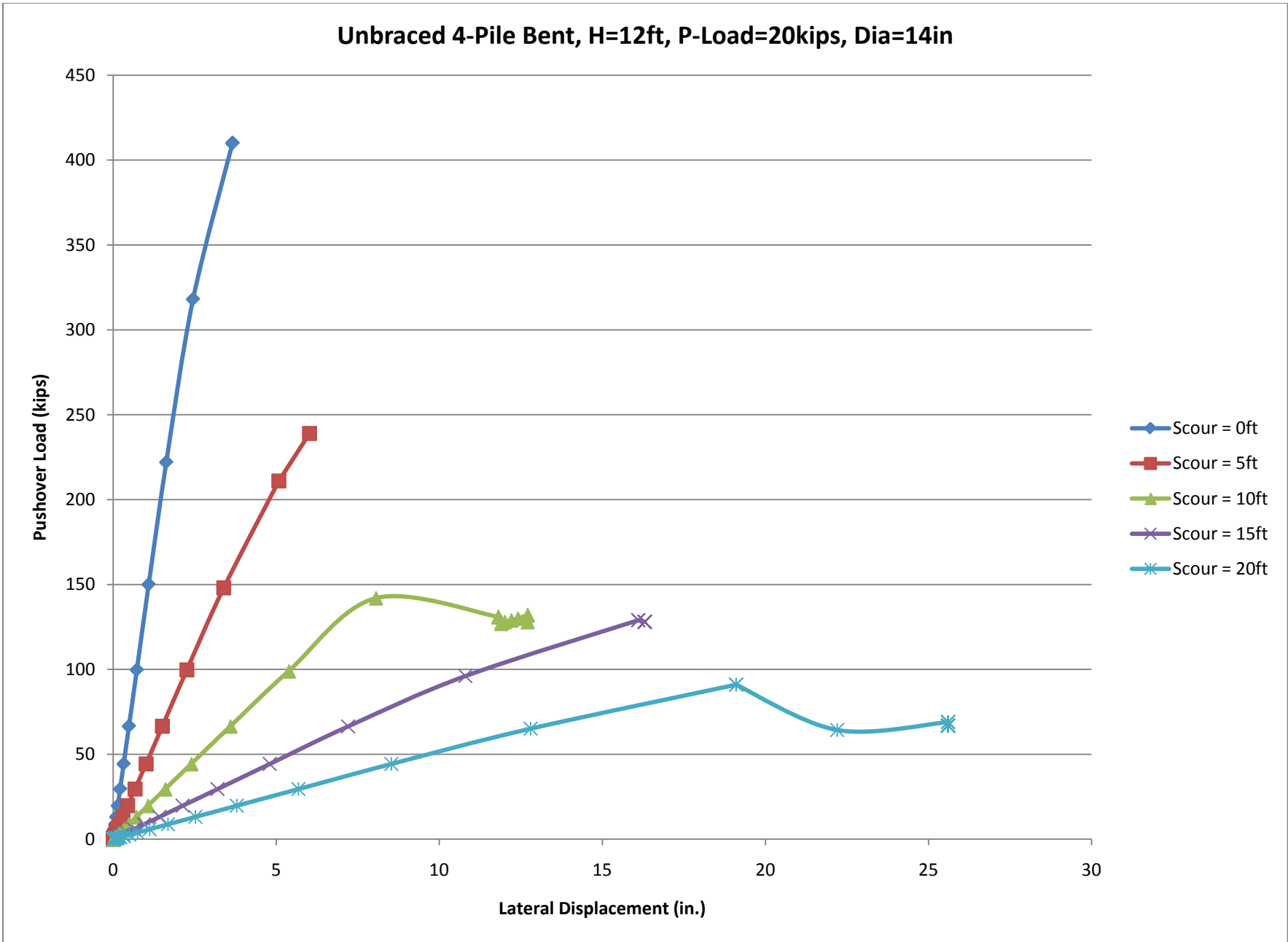


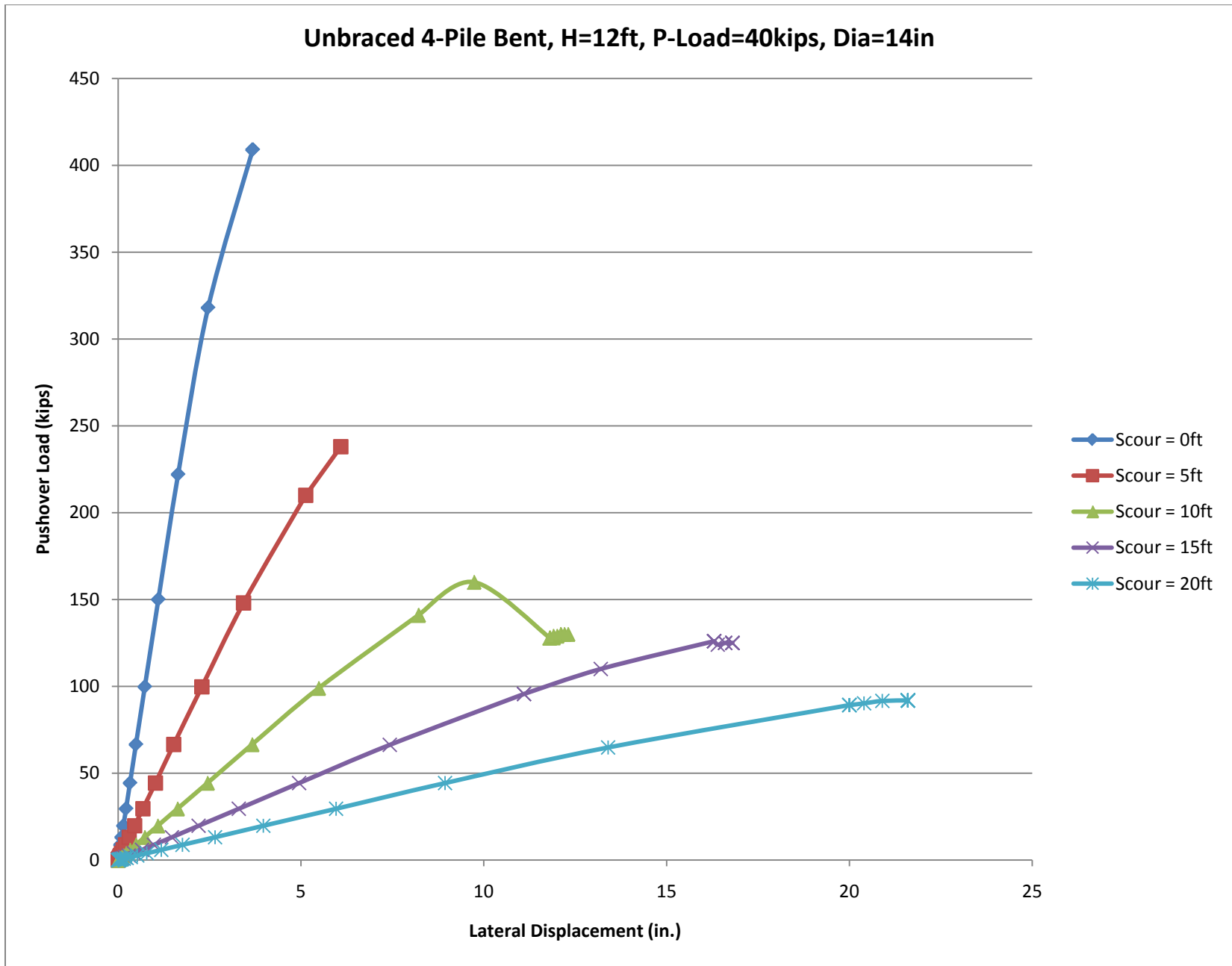
Figure B.29 Pushover Curves for Unbraced 4-Pile Bent, H=8ft, P=40kips, Diameter=14in, Multiple Levels of Scour



**Figure B.30 Pushover Curves for Unbraced 4-Pile Bent, H=8ft, P=60kips, Diameter=14in, Multiple Levels of Scour**  
254



**Figure B.31 Pushover Curves for Unbraced 4-Pile Bent, H=12ft, P=20kips, Diameter=14in, Multiple Levels of Scour**  
255



**Figure B.32 Pushover Curves for Unbraced 4-Pile Bent, H=12ft, P=40kips, Diameter=14in, Multiple Levels of Scour**

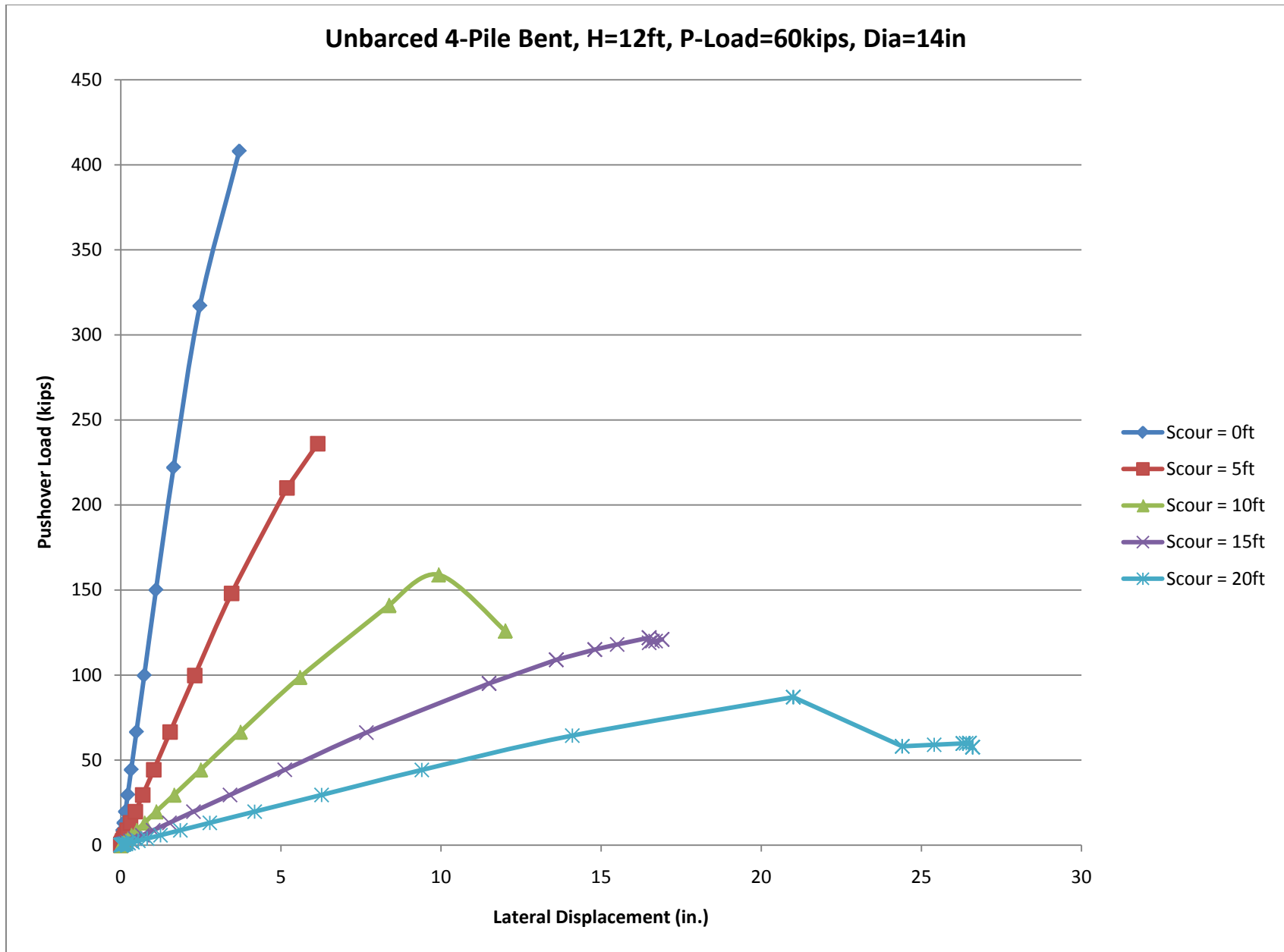
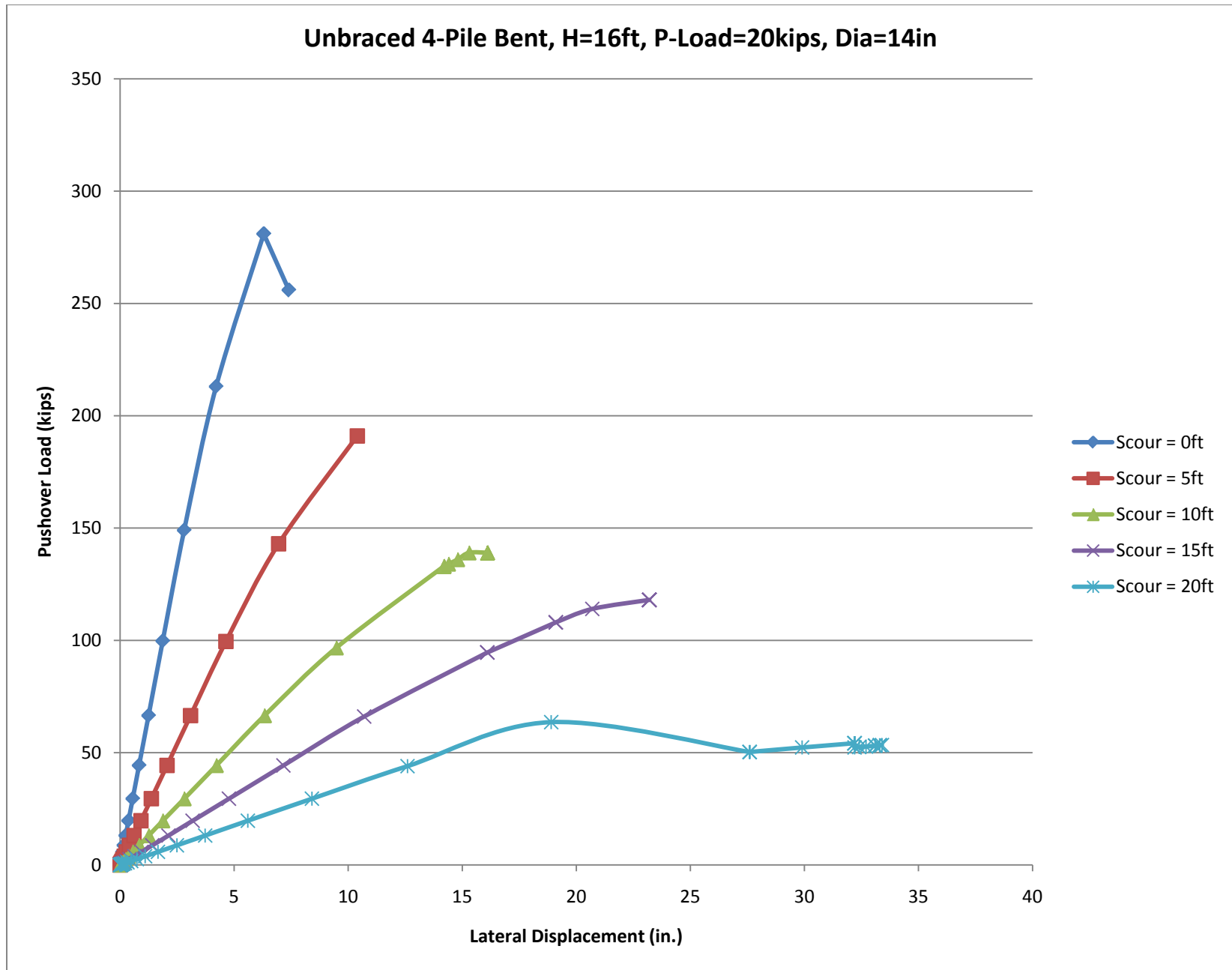
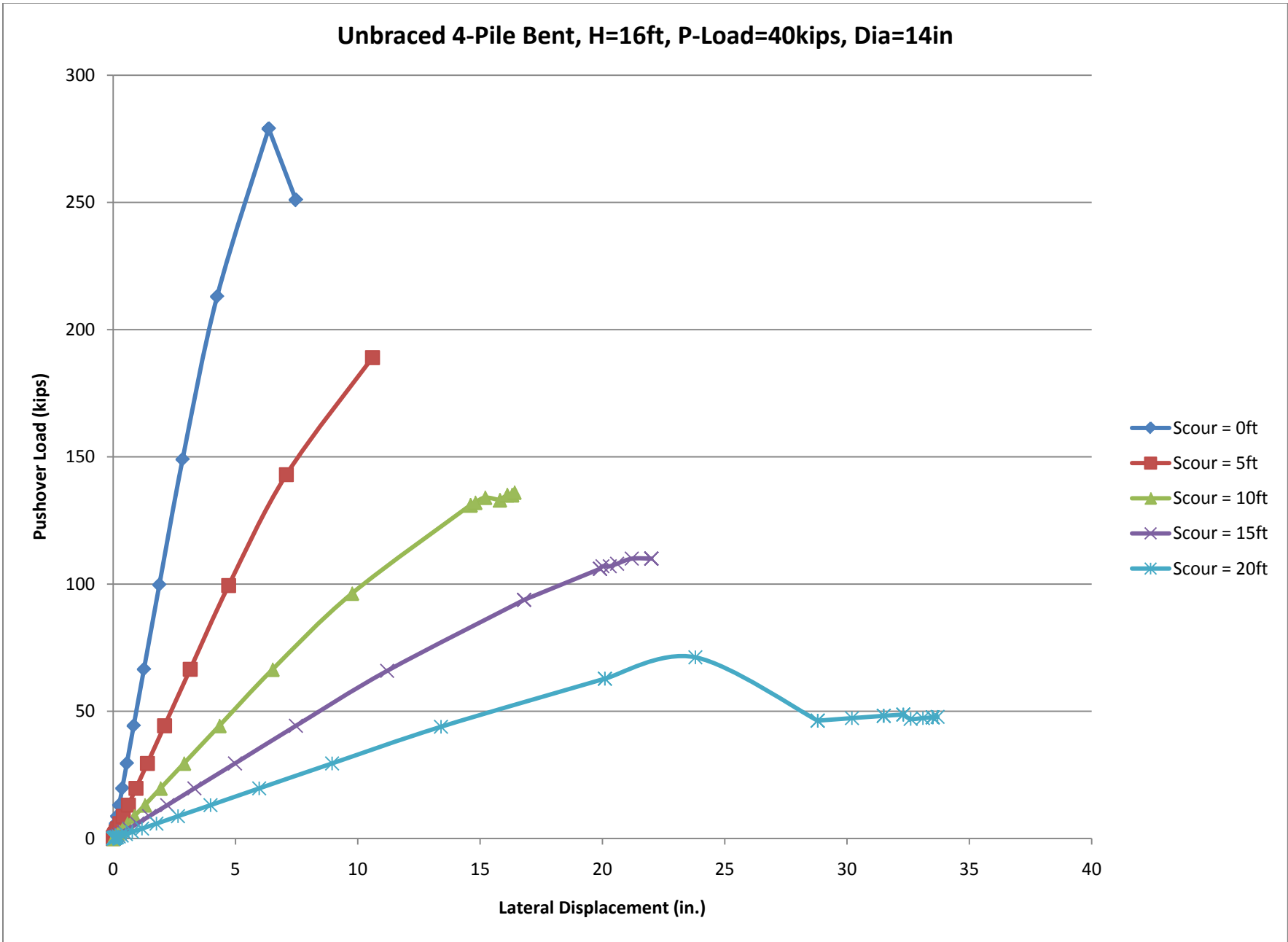


Figure B.33 Pushover Curves for Unbraced 4-Pile Bent, H=12ft, P=60kips, Diameter=14in, Multiple Levels of Scour

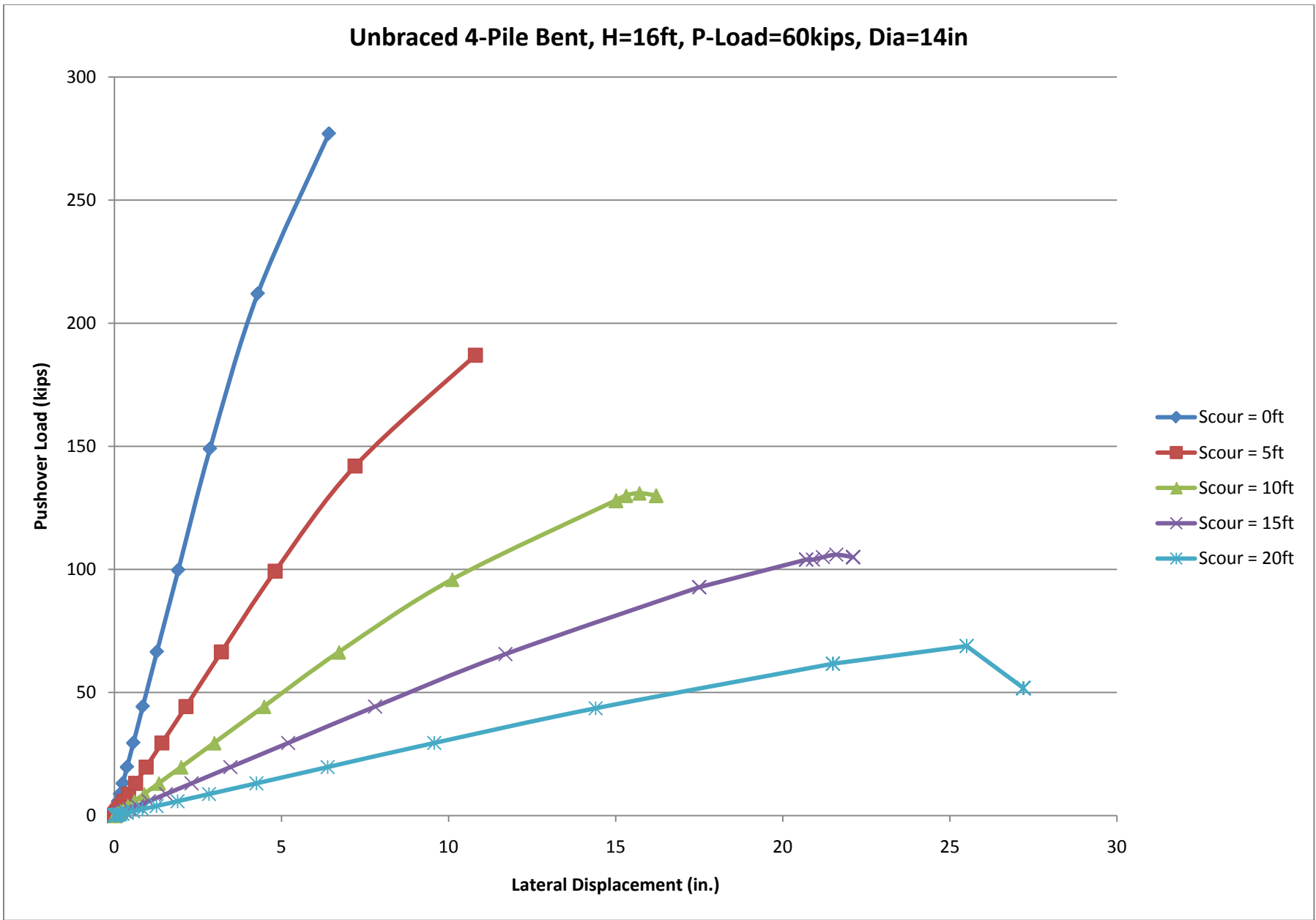




**Figure B.34 Pushover Curves for Unbraced 4-Pile Bent, H=16ft, P=20kips, Diameter=14in, Multiple Levels of Scour**



**Figure B.35 Pushover Curves for Unbraced 4-Pile Bent, H=16ft, P=40kips, Diameter=14in, Multiple Levels of Scour**



**Figure B.36 Pushover Curves for Unbraced 4-Pile Bent, H=16ft, P=60kips, Diameter=14in, Multiple Levels of Scour**

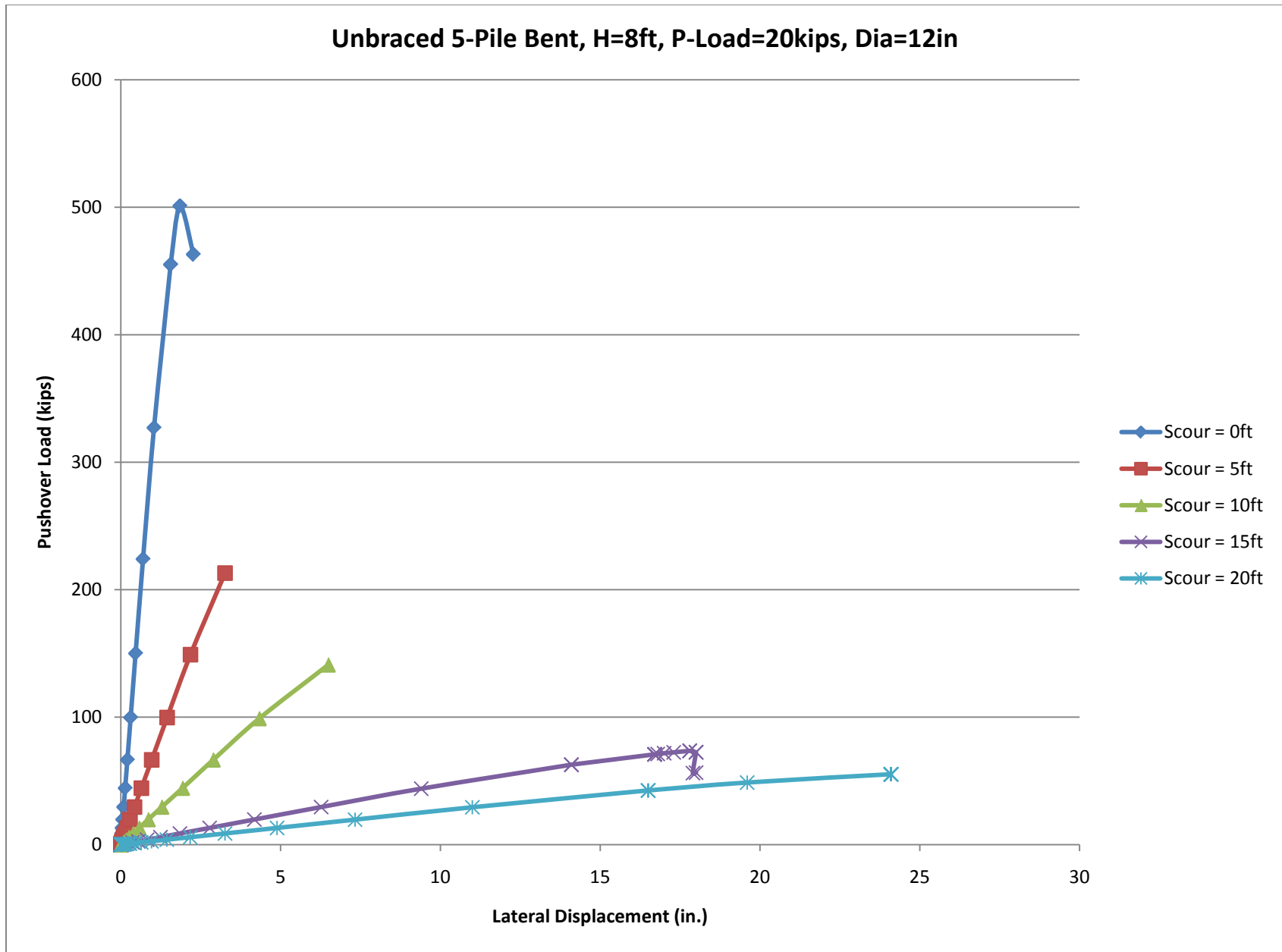


Figure B.37 Pushover Curves for Unbraced 5-Pile Bent, H=8ft, P=20kips, Diameter=12in, Multiple Levels of Scour

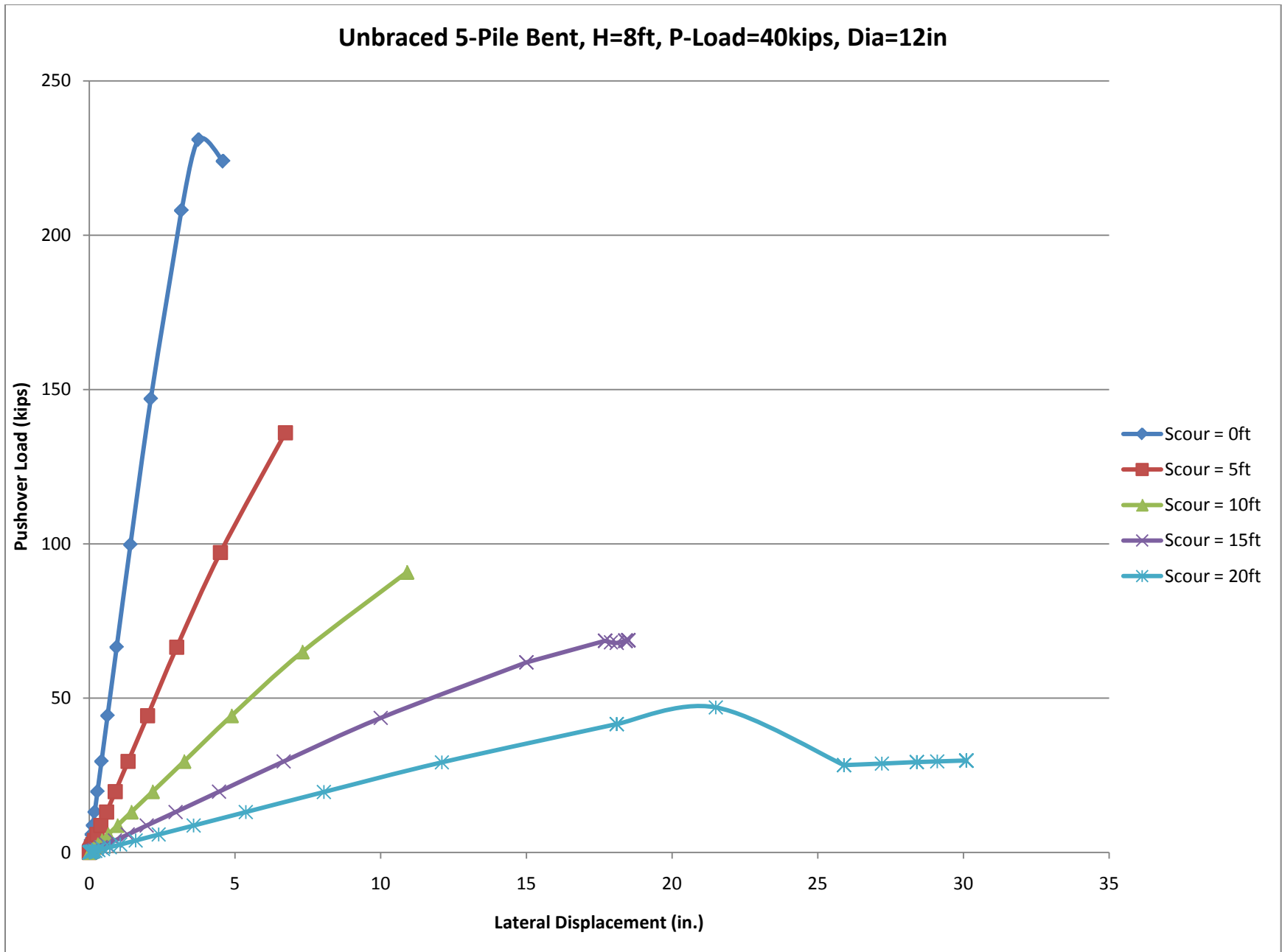
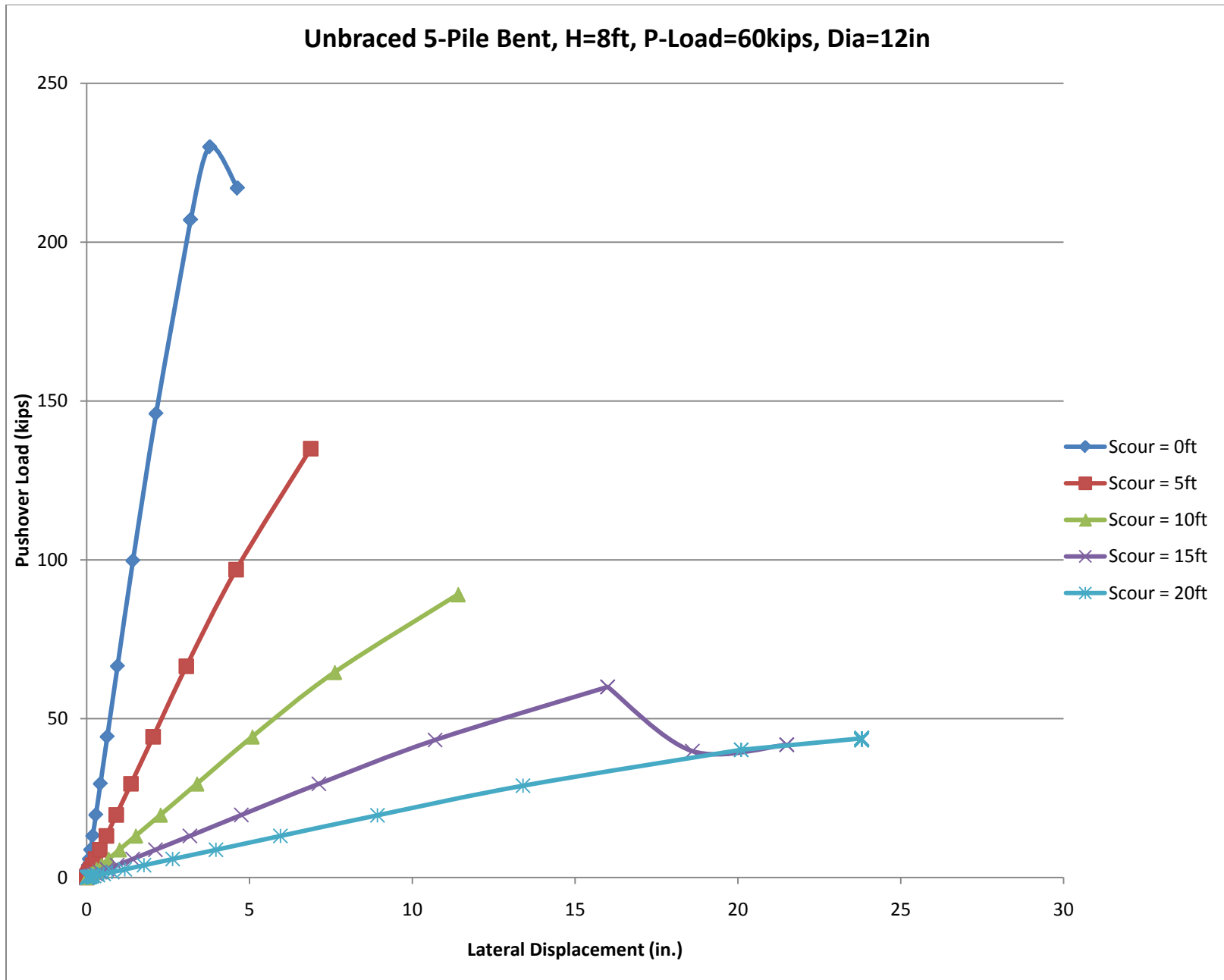
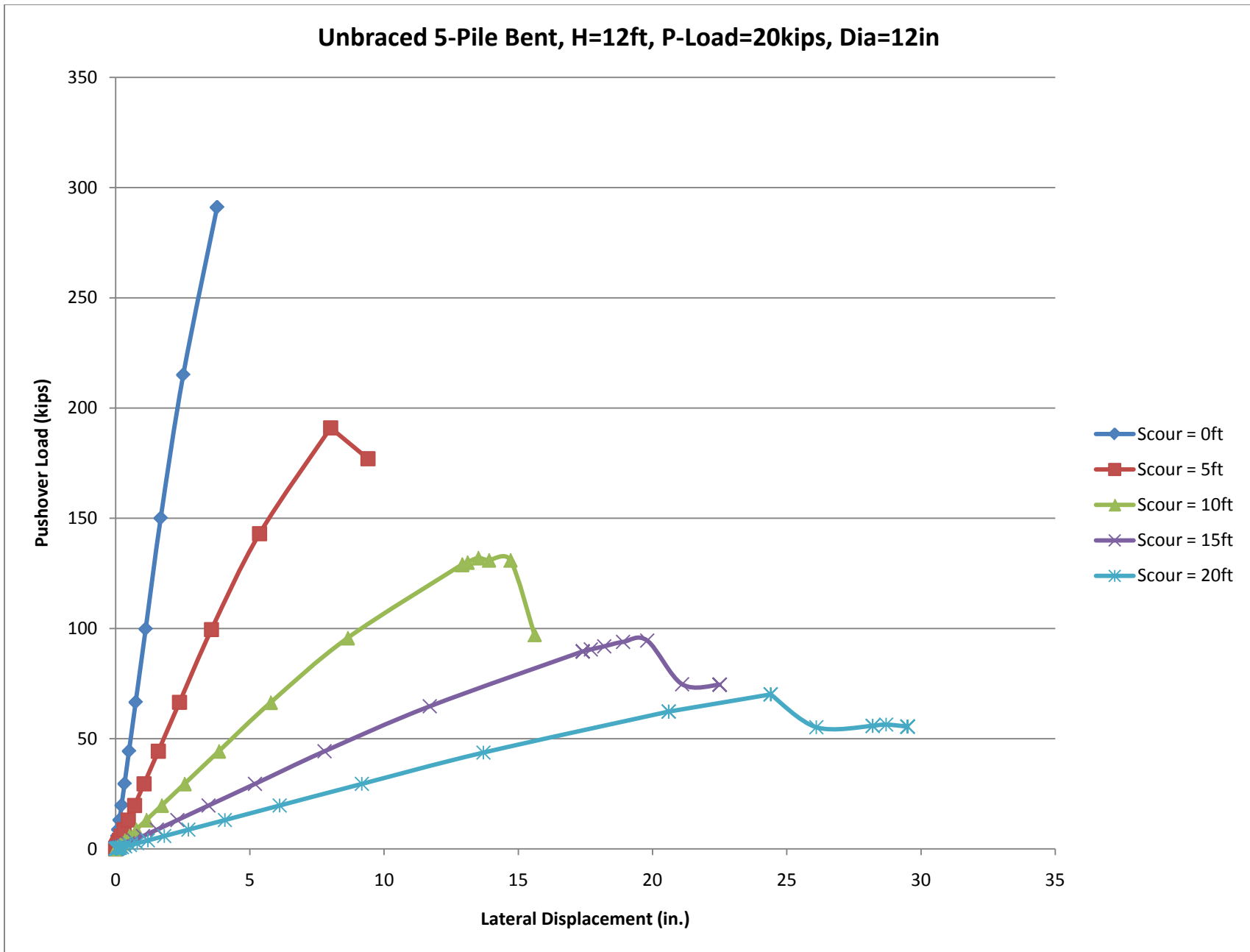


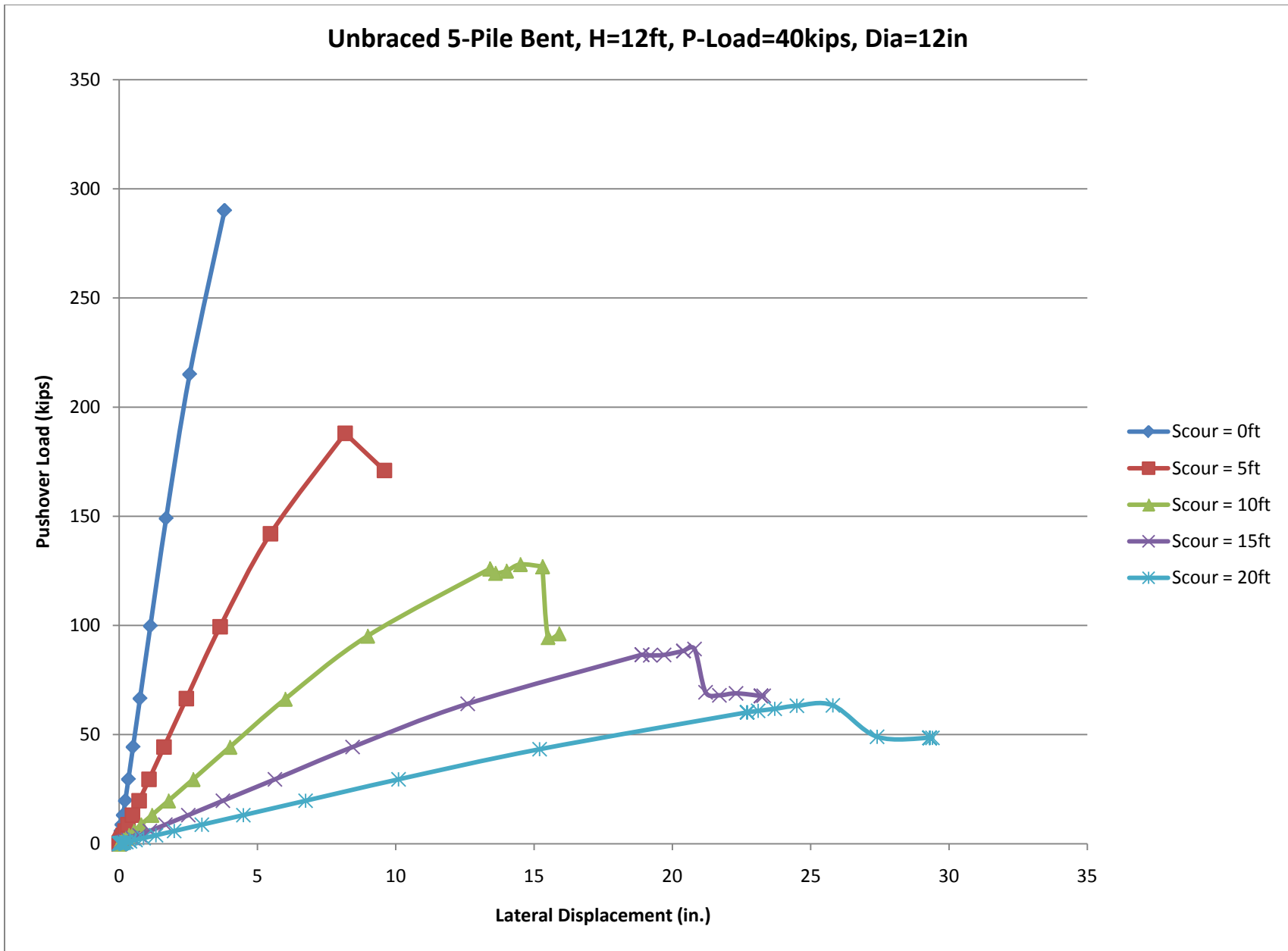
Figure B.38 Pushover Curves for Unbraced 5-Pile Bent, H=8ft, P=40kips, Diameter=12in, Multiple Levels of Scour



**Figure B.39 Pushover Curves for Unbraced 5-Pile Bent, H=8ft, P=60kips, Diameter=12in, Multiple Levels of Scour**



**Figure B.40 Pushover Curves for Unbraced 5-Pile Bent, H=12ft, P=20kips, Diameter=12in, Multiple Levels of Scour**  
264



**Figure B.41 Pushover Curves for Unbraced 5-Pile Bent, H=12ft, P=40kips, Diameter=12in, Multiple Levels of Scour**



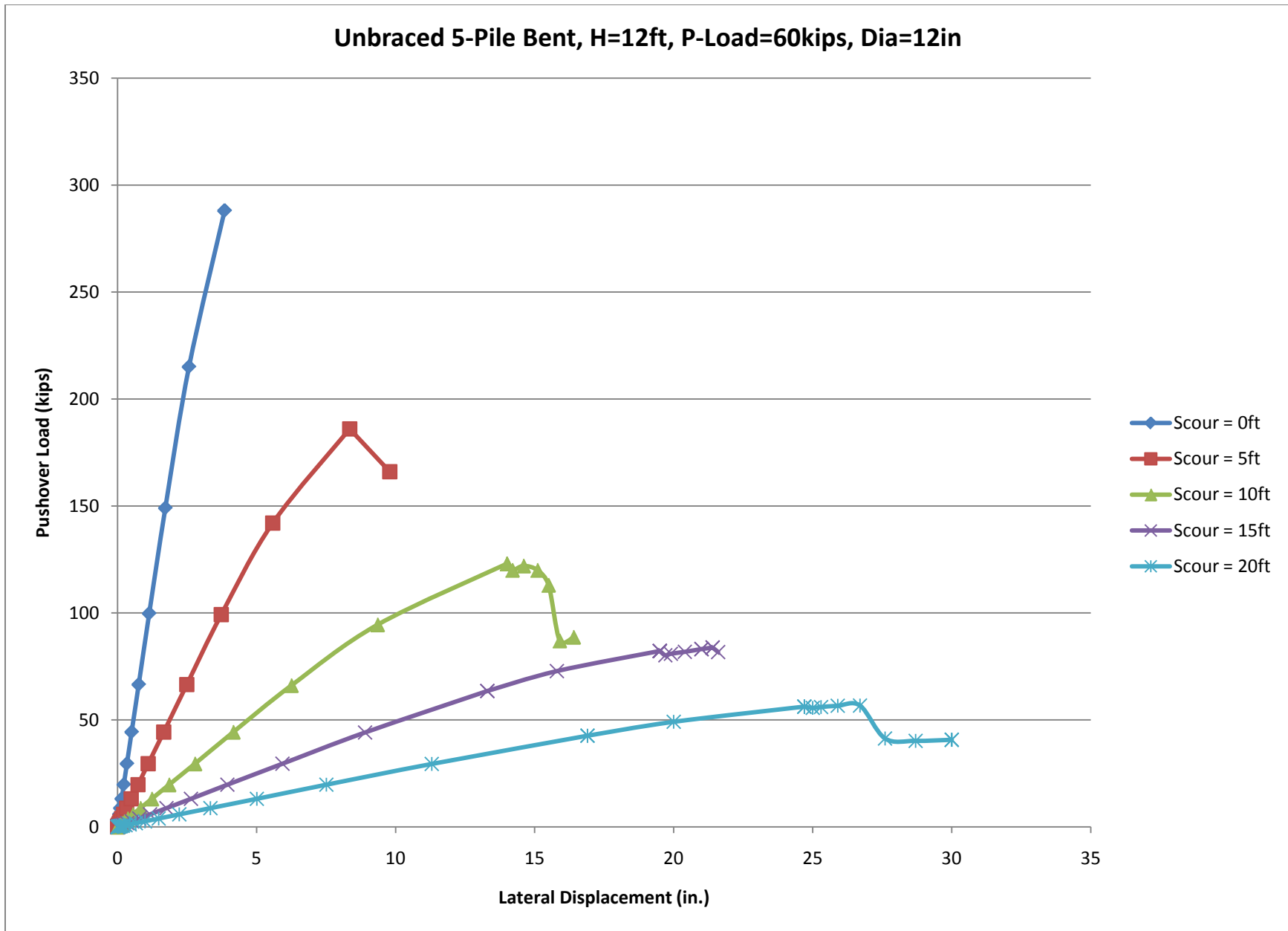
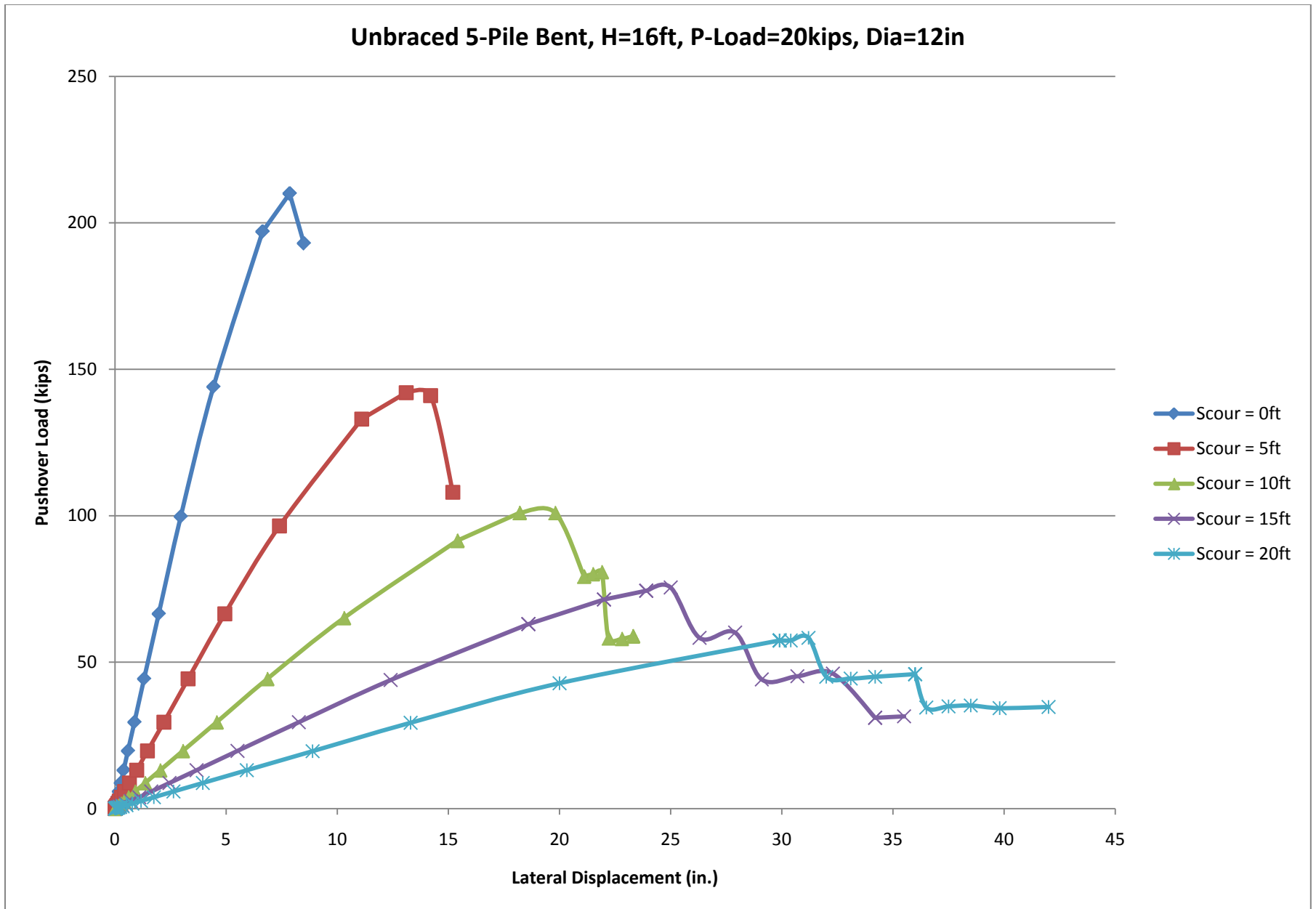


Figure B.42 Pushover Curves for Unbraced 5-Pile Bent, H=12ft, P=60kips, Diameter=12in, Multiple Levels of Scour



**Figure B.43 Pushover Curves for Unbraced 5-Pile Bent, H=16ft, P=20kips, Diameter=12in, Multiple Levels of Scour**

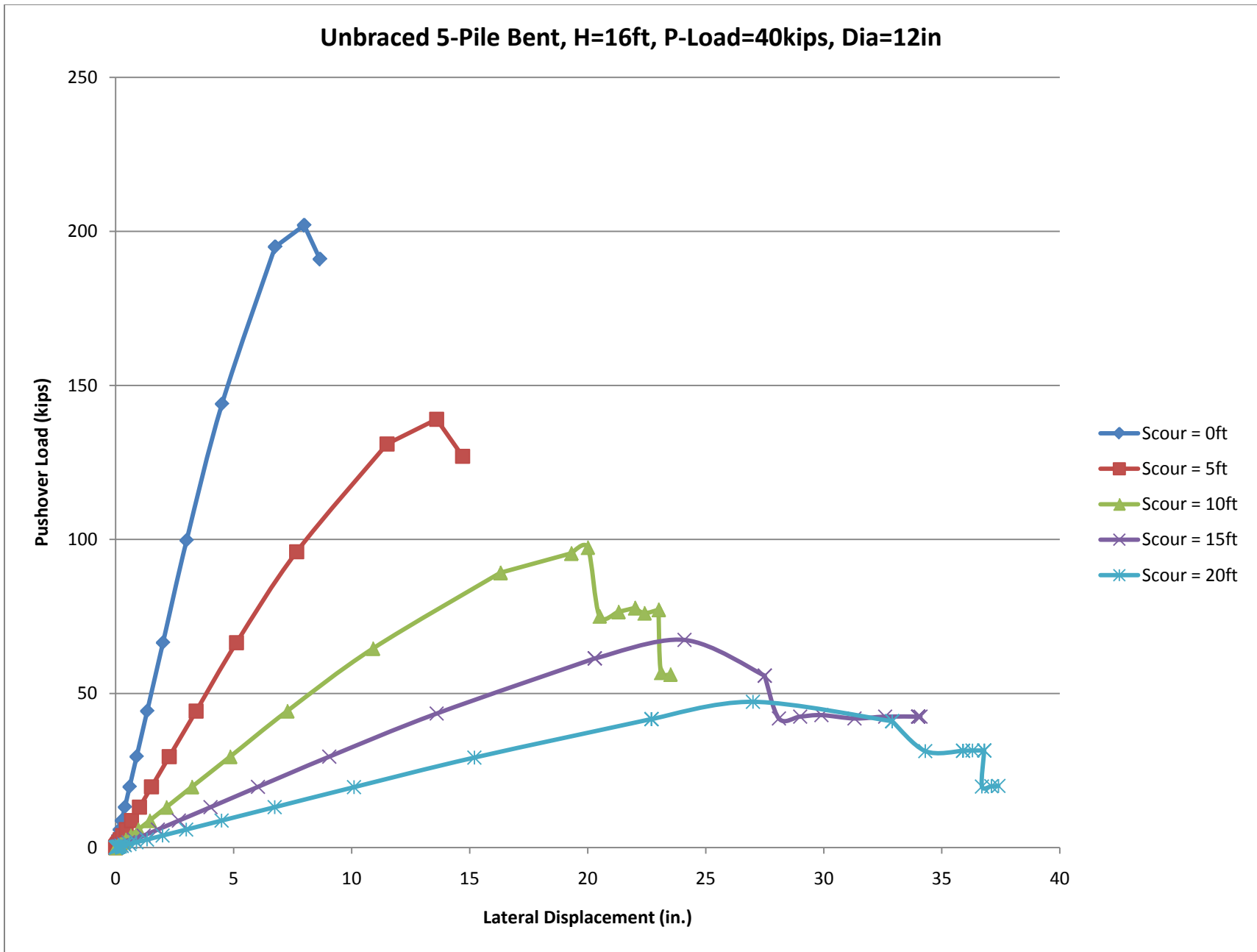
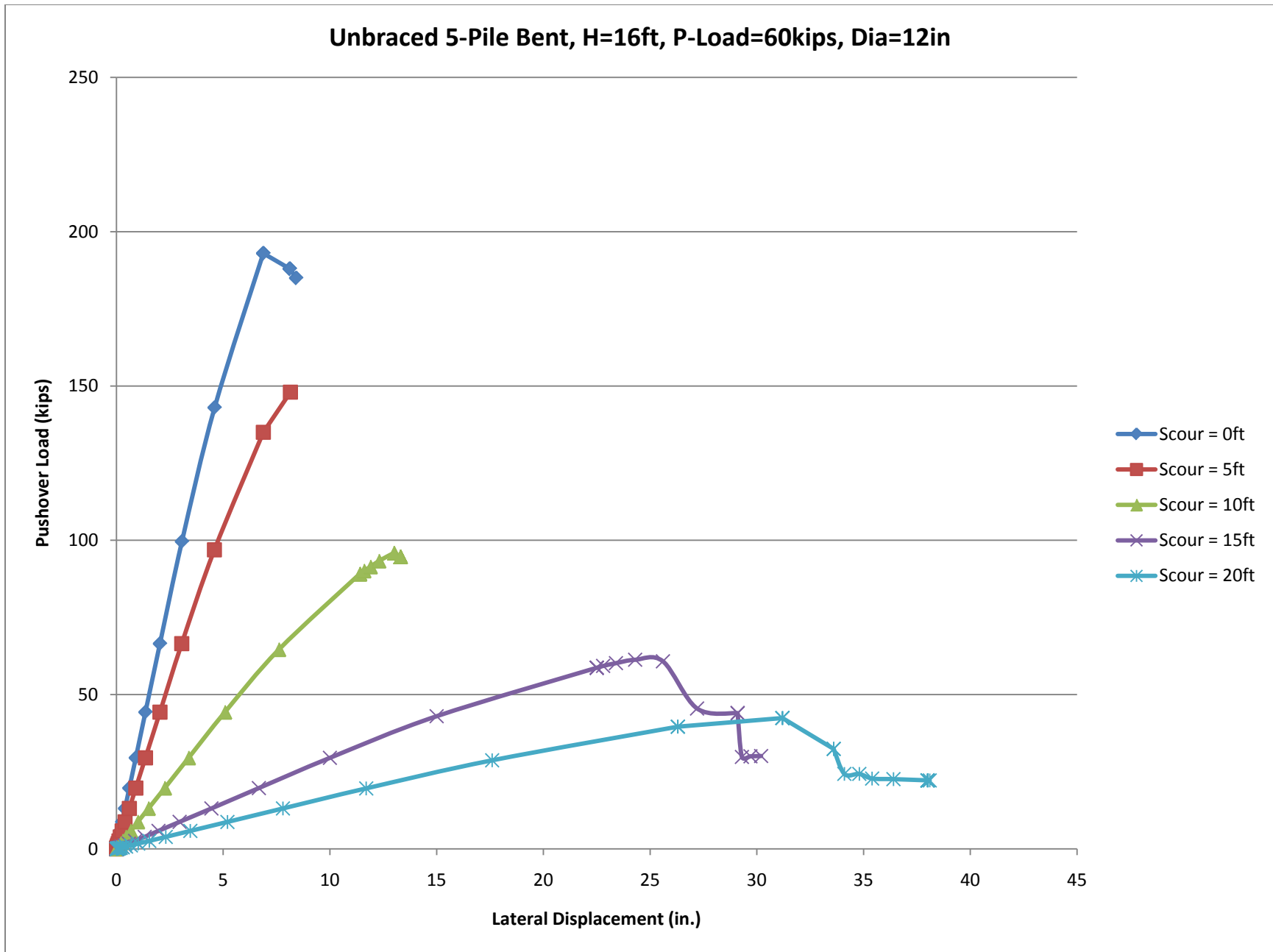
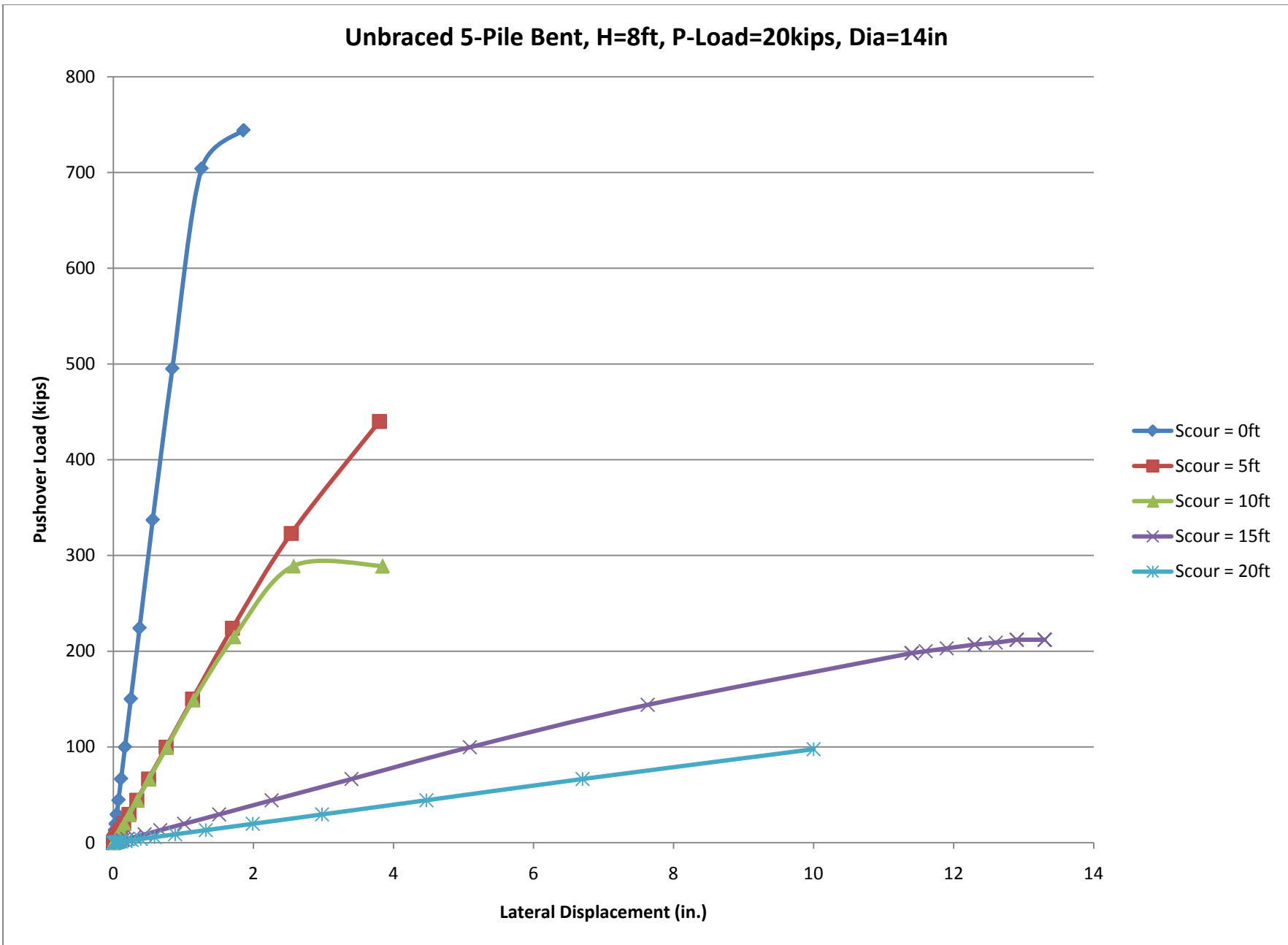


Figure B.44 Pushover Curves for Unbraced 5-Pile Bent, H=16ft, P=40kips, Diameter=12in, Multiple Levels of Scour



**Figure B.45 Pushover Curves for Unbraced 5-Pile Bent, H=16ft, P=60kips, Diameter=12in, Multiple Levels of Scour**  
269



**Figure B.46 Pushover Curves for Unbraced 5-Pile Bent, H=8ft, P=20kips, Diameter=14in, Multiple Levels of Scour**  
270

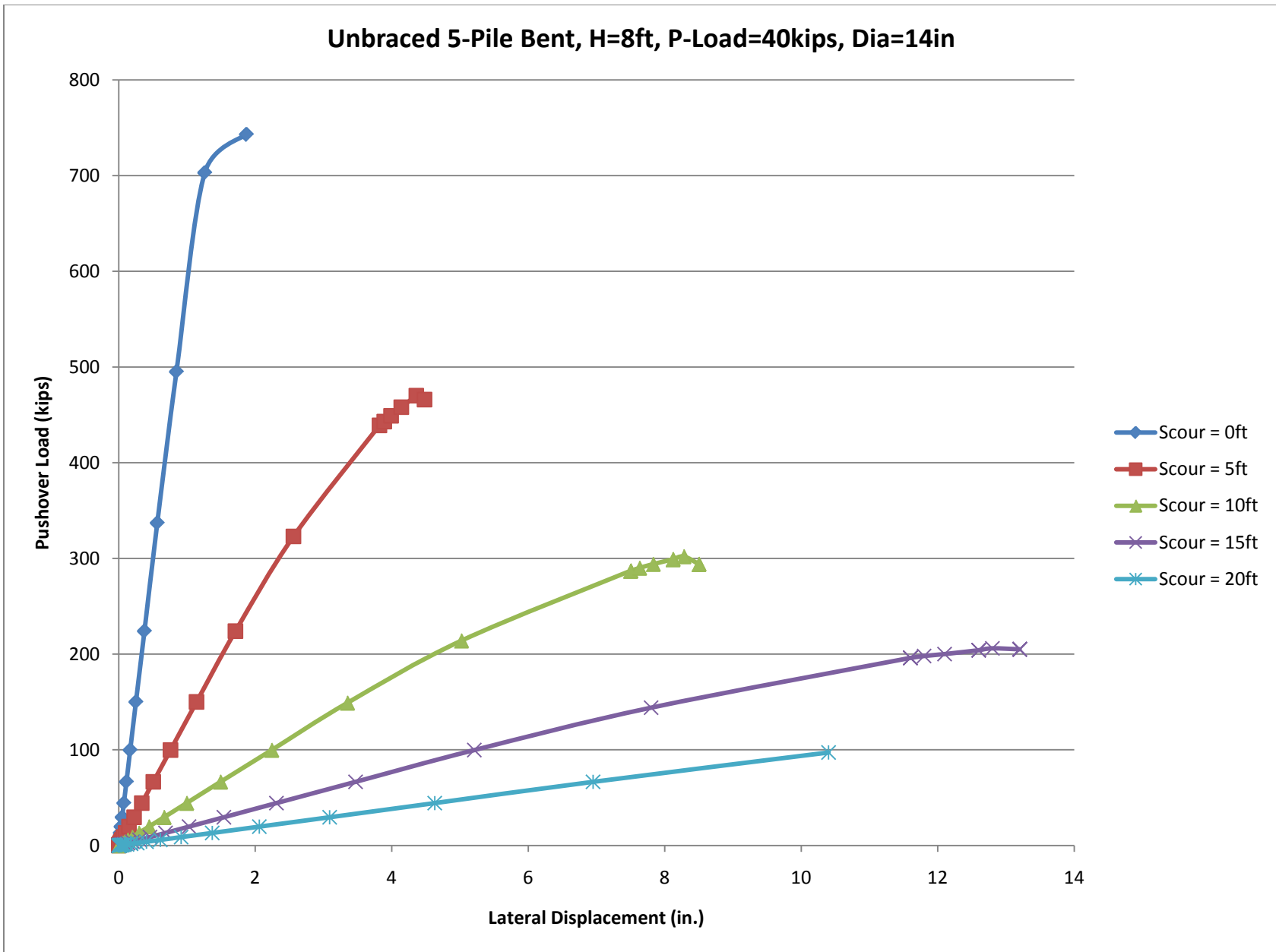
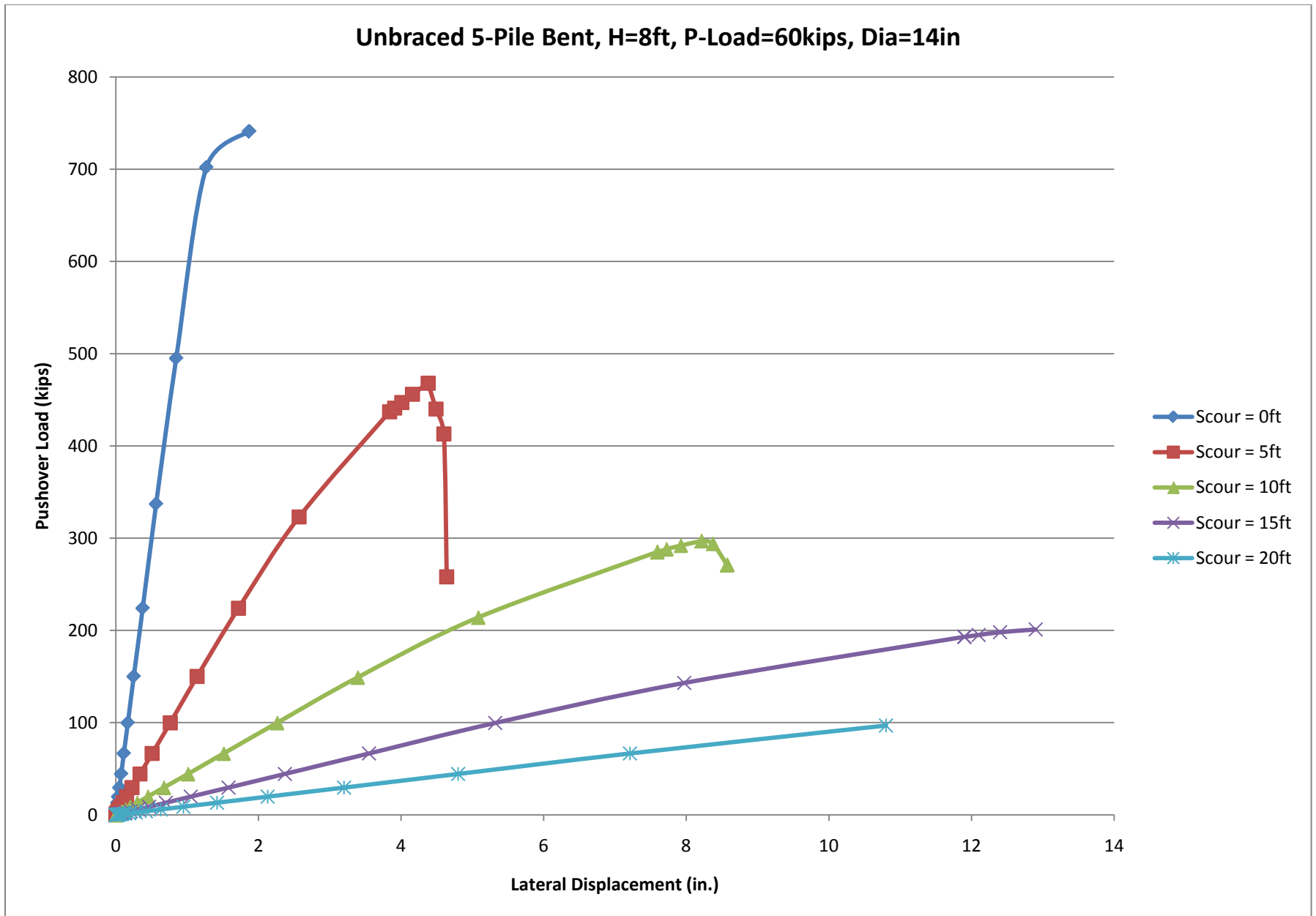


Figure B.47 Pushover Curves for Unbraced 5-Pile Bent, H=8ft, P=40kips, Diameter=14in, Multiple Levels of Scour



**Figure B.48 Pushover Curves for Unbraced 5-Pile Bent, H=8ft, P=60kips, Diameter=14in, Multiple Levels of Scour**

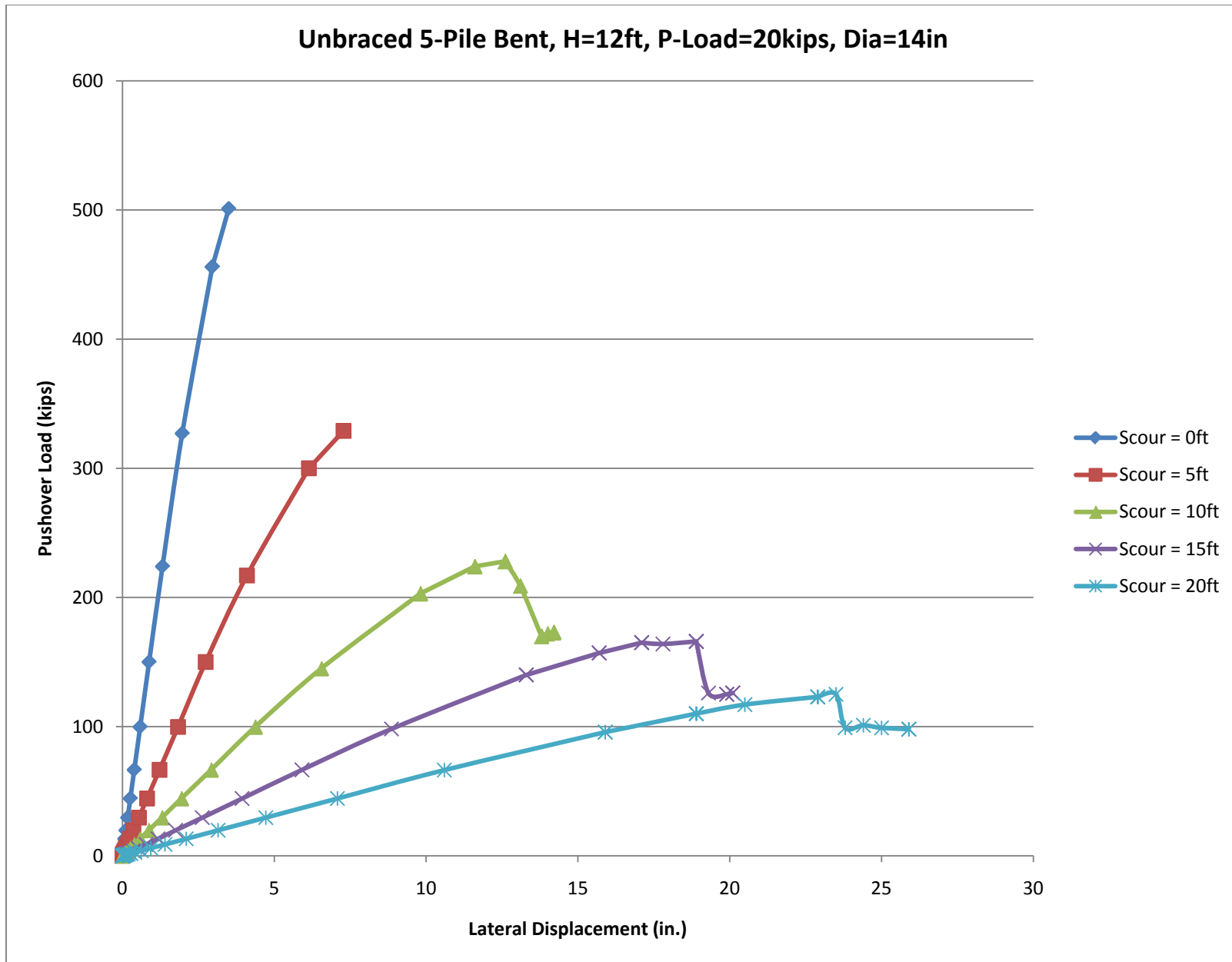


Figure B.49 Pushover Curves for Unbraced 5-Pile Bent, H=12ft, P=20kips, Diameter=14in, Multiple Levels of Scour



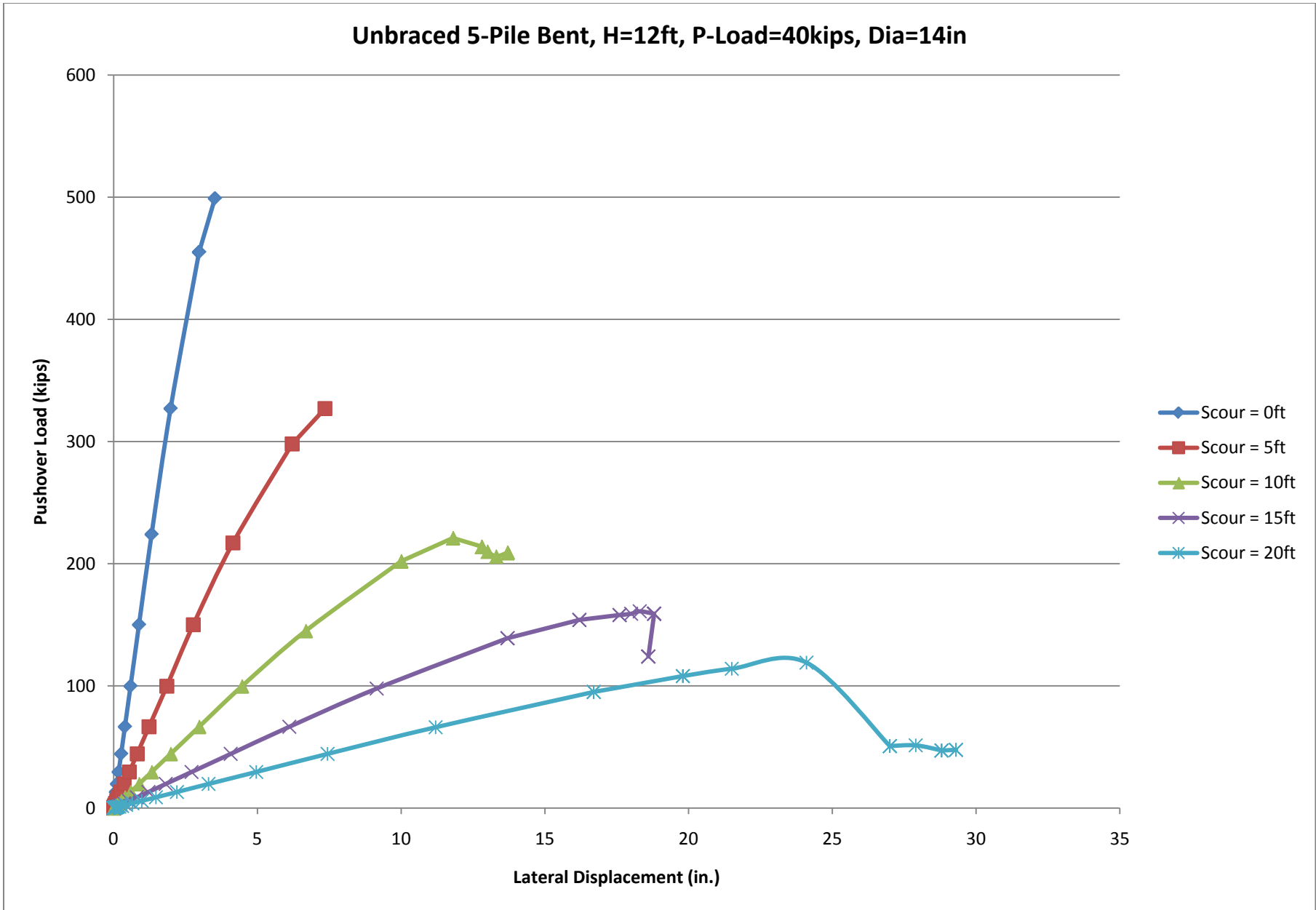


Figure B.50 Pushover Curves for Unbraced 5-Pile Bent, H=12ft, P=40kips, Diameter=14in, Multiple Levels of Scour

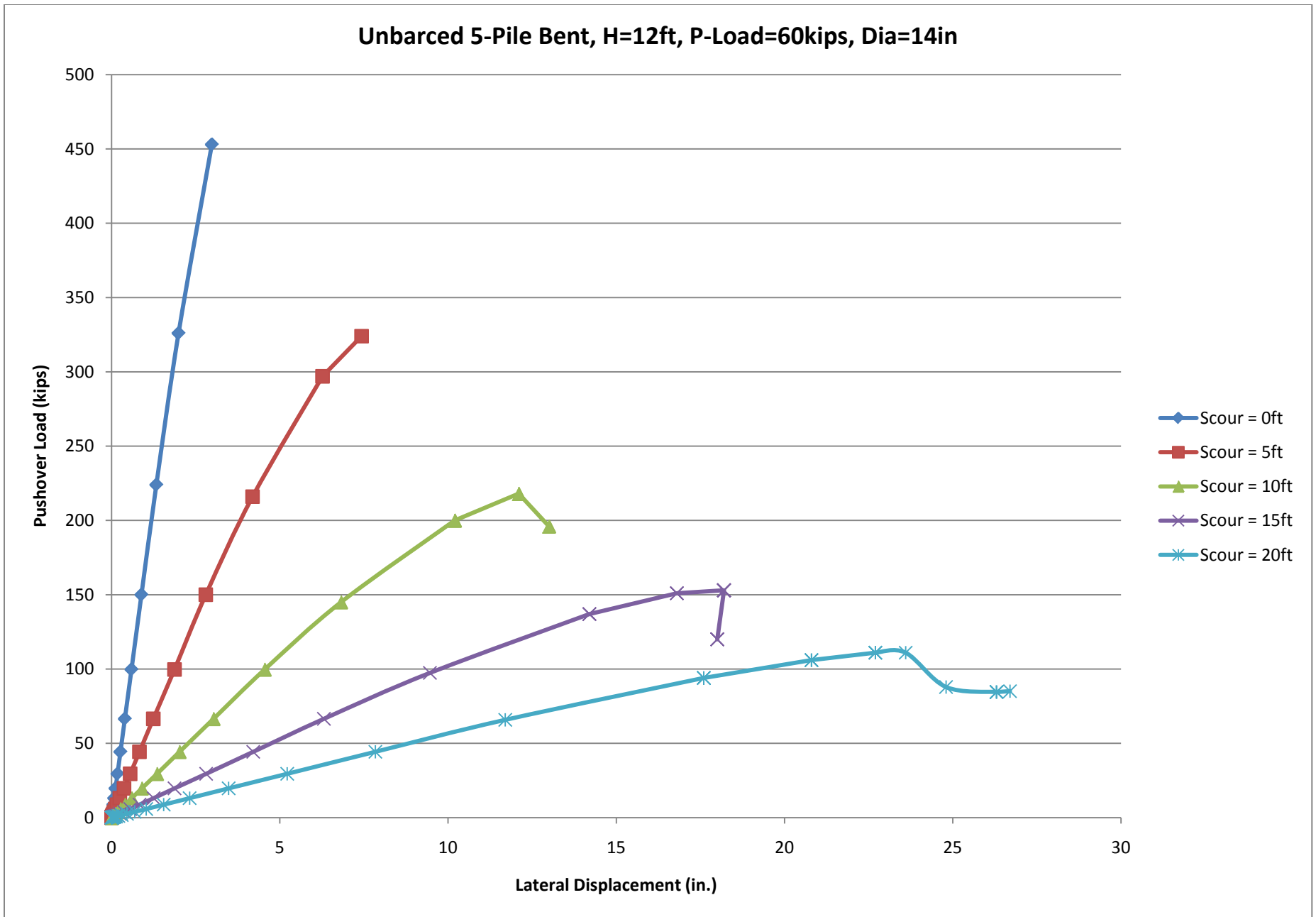


Figure B.51 Pushover Curves for Unbraced 5-Pile Bent, H=12ft, P=60kips, Diameter=14in, Multiple Levels of Scour

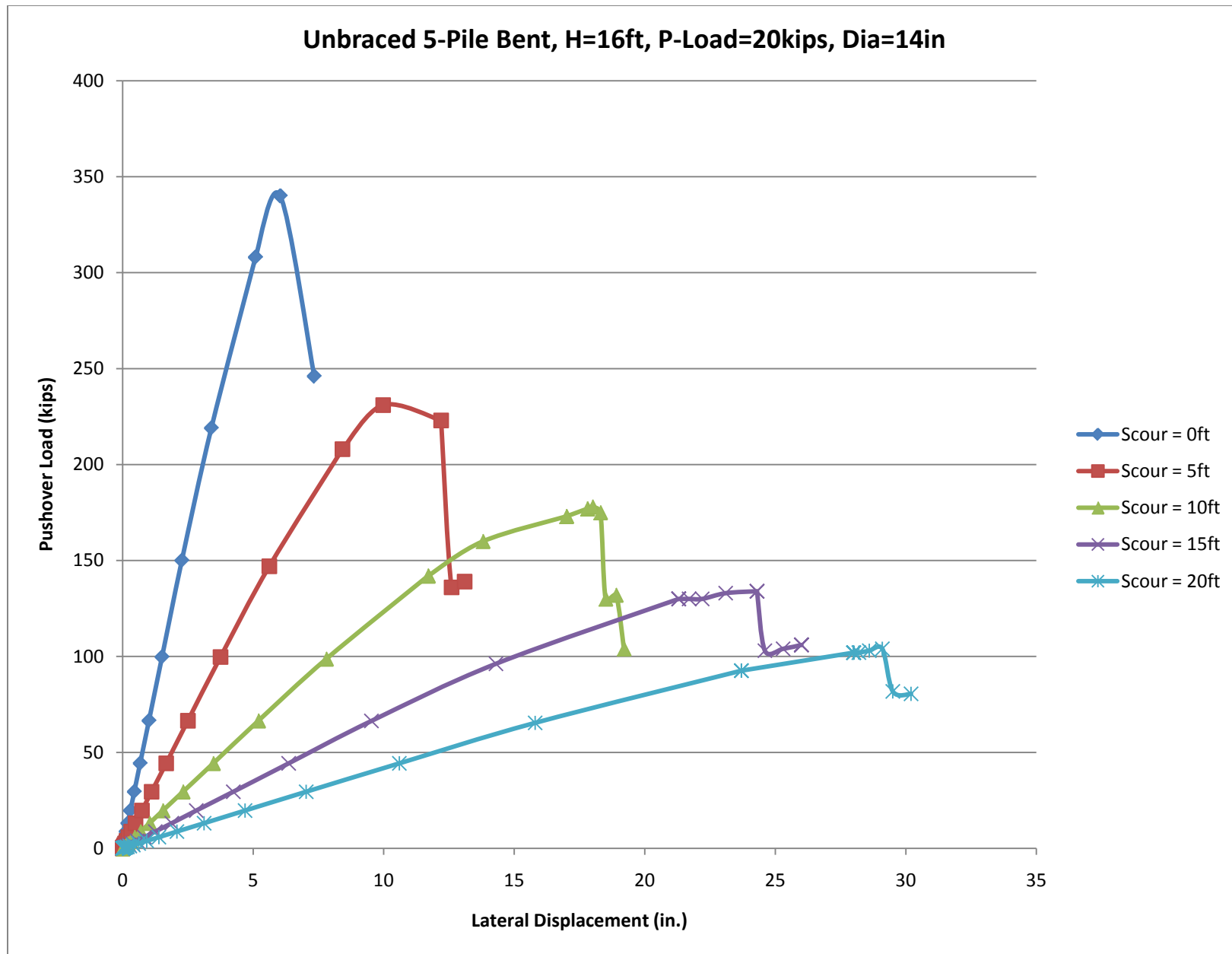


Figure B.52 Pushover Curves for Unbraced 5-Pile Bent, H=16ft, P=20kips, Diameter=14in, Multiple Levels of Scour

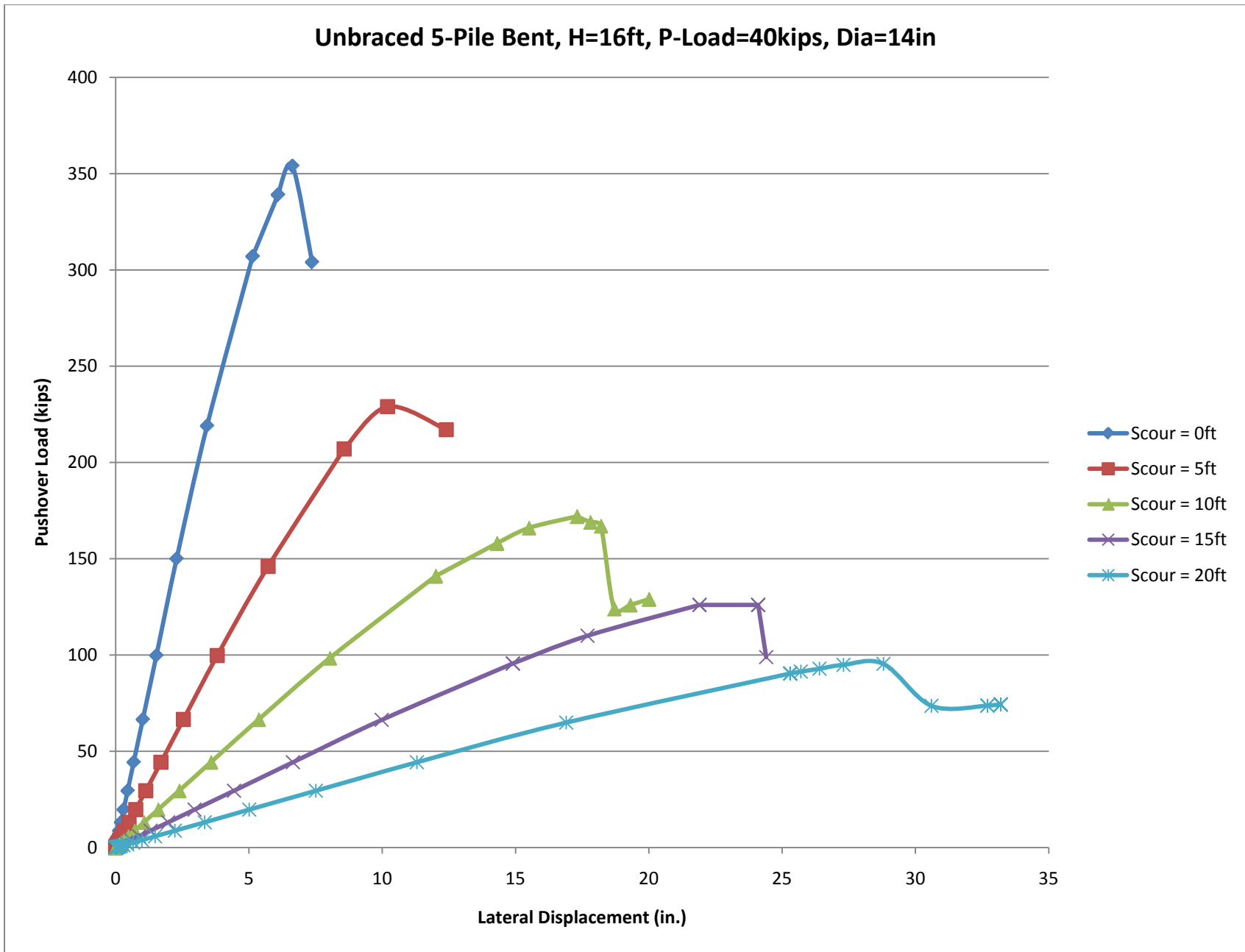
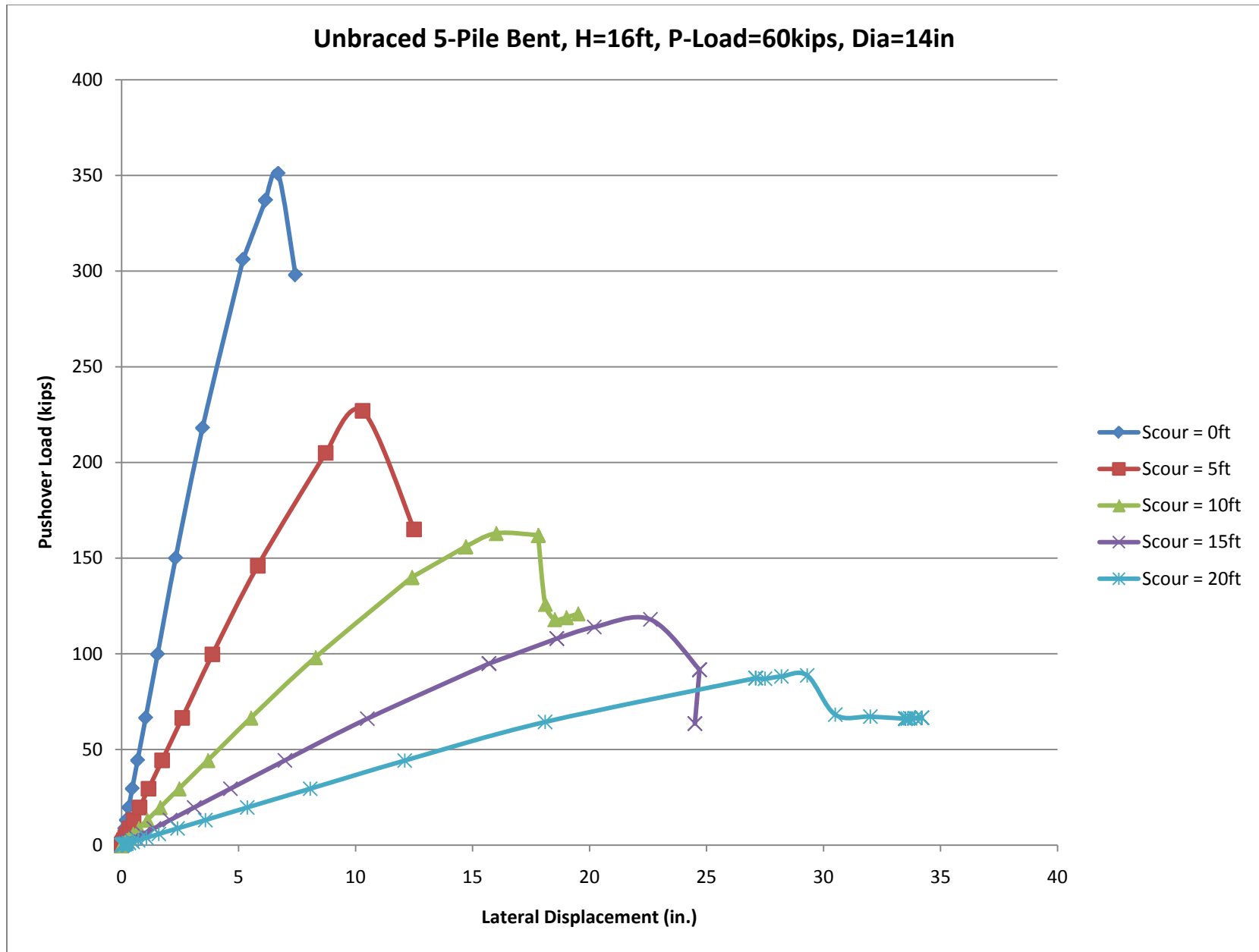


Figure B.53 Pushover Curves for Unbraced 5-Pile Bent, H=16ft, P=40kips, Diameter=14in, Multiple Levels of Scour

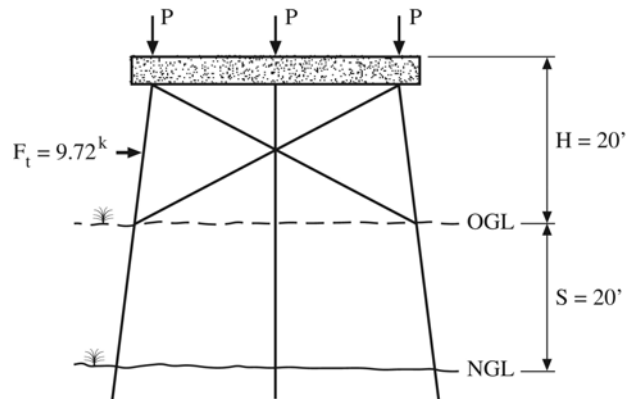


**Figure B.54 Pushover Curves for Unbraced 5-Pile Bent, H=16ft, P=60kips, Diameter=14in, Multiple Levels of Scour**

## **APPENDIX C**

### **Beam-Column Analyses**

For the following braced bent geometry:  $H = 20$  ft,  $S = 20$  ft, 3-Pile Bent, Debris Raft Force,  $F_t = 9.72$  kips



From the moment diagram:

$$M_{F_t} = \frac{13}{64} \cdot 9.72 \text{ kips} \cdot 16 \text{ ft} = 31.6 \text{ kip} \cdot \text{ft} = M_{\text{Max}} \quad M_{\text{HB}} = \frac{3}{32} \cdot 9.72 \text{ kips} \cdot 16 \text{ ft} = 14.6 \text{ kip} \cdot \text{ft}$$

Checking at the location of debris raft force  $F_t$ :

$$d_{F_t} = 12 \text{ in} - \left( 8.5 \text{ ft} \cdot 0.12 \frac{\text{in}}{\text{ft}} \right) = 10.98 \text{ in} \quad A_{F_t} = \frac{\pi \cdot (10.98 \text{ in})^2}{4} = 94.7 \text{ in}^2$$

$$S_{F_t} = \frac{\pi \cdot (10.98 \text{ in})^3}{32} = 130 \text{ in}^3$$

Checking at horizontal brace using effective section properties:

$$d_{\text{eff}} = 12 \text{ in} - \left( 25.83 \text{ ft} \cdot 0.12 \frac{\text{in}}{\text{ft}} \right) = 8.90 \text{ in} \quad I_{\text{eff}} = \frac{\pi \cdot (8.90 \text{ in})^4}{64} = 308 \text{ in}^4$$

Also must check  $P_{\text{cr}}$  for buckling in unbraced region exposed due to scour:

$$P_{\text{cr}} = \frac{2 \cdot \pi^2 \cdot E \cdot I_{\text{eff}}}{L^2} = \frac{2 \cdot \pi^2 \cdot 1800 \text{ ksi} \cdot 308 \text{ in}^4}{(21.5 \text{ ft} \cdot 12)^2} = 168.3 \text{ kips}$$

Recall,

$$\sigma_{\text{rupture}} = 12.0 \text{ ksi} \quad \rightarrow \quad M_{\text{rupture}} = \sigma_{\text{rupture}} \cdot S_{F_t} = 12 \text{ ksi} \cdot 97.8 \cdot \text{in}^3 = 97.8 \text{ kip} \cdot \text{ft}$$

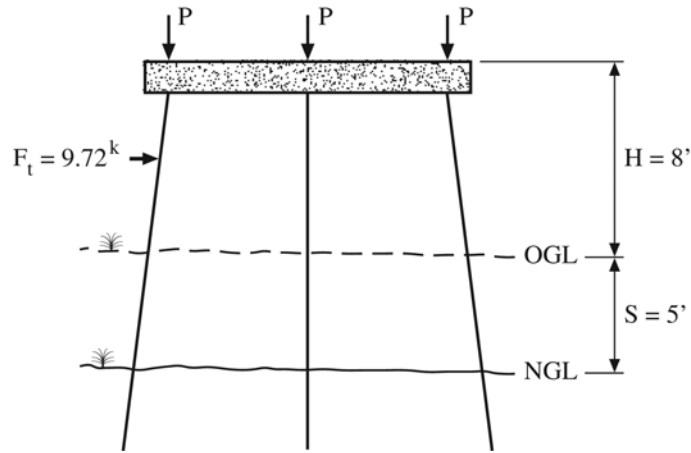
$$\sigma_{\text{crushing}} = 7.0 \text{ ksi} \quad \rightarrow \quad P_{\text{crushing}} = \sigma_{\text{crushing}} \cdot A_{F_t} = 7 \text{ ksi} \cdot 78.3 \cdot \text{in}^2 = 548.1 \text{ kips}$$

Therefore section is controlled by buckling, rather than crushing.

$$\frac{P_{\text{axial}}}{P_{\text{cr}}} + \frac{M_{\text{Max}}}{M_{\text{rupture}}} = \frac{60 \cdot \text{kips}}{168.3 \cdot \text{kips}} + \frac{31.6 \cdot \text{kip} \cdot \text{ft}}{97.8 \cdot \text{kip} \cdot \text{ft}} = 0.35 + 0.32 = 0.67 < 0.75 \rightarrow \text{OK!}$$

Note that all braced bents therefore will be safe.

For the following unbraced bent geometry:  $H = 8$  ft,  $S = 5$  ft, 3-Pile Bent,  $F_t = 9.72$  kips



Checking at the location of effective section, 3.92 ft above NGL as shown in figure, with a 12in pile:

$$d_{\text{eff}} = 12\text{in} - \left(7.83\text{ft} \cdot 0.12 \frac{\text{in}}{\text{ft}}\right) = 11.06\text{in}$$

$$I_{\text{eff}} = \frac{\pi \cdot (11.06\text{in})^4}{64} = 734.5\text{in}^4$$

$$A_{\text{eff}} = \frac{\pi \cdot (11.06\text{in})^2}{4} = 96.0\text{in}^2$$

$$S_{\text{eff}} = \frac{\pi \cdot (11.06\text{in})^3}{32} = 132.8\text{in}^3$$

$$P_{\text{cr}} = \frac{0.25 \cdot \pi^2 \cdot E \cdot I_{\text{eff}}}{L^2} = \frac{0.25 \cdot \pi^2 \cdot 1800\text{ksi} \cdot 734.5\text{in}^4}{(11.75\text{ft} \cdot 12)^2} = 164\text{ kips} \rightarrow \text{OK! for } P \leq 60\text{ kips in buckling}$$

Check at interaction equation at base (smallest section, therefore most critical):

$$d_{\text{base}} = 12\text{in} - \left(11.75\text{ft} \cdot 0.12 \frac{\text{in}}{\text{ft}}\right) = 10.59\text{in}$$

$$I_{\text{base}} = \frac{\pi \cdot (10.59\text{in})^4}{64} = 617\text{in}^4$$

$$A_{\text{base}} = \frac{\pi \cdot (10.59\text{in})^2}{4} = 88.1\text{in}^2$$

$$S_{\text{base}} = \frac{\pi \cdot (10.59\text{in})^3}{32} = 116\text{in}^3$$

Recall,

$$\sigma_{\text{rupture}} = 12.0\text{ ksi} \quad \rightarrow \quad M_{\text{rupture}} = \sigma_{\text{rupture}} \cdot S_{\text{base}} = 12\text{ksi} \cdot 116\text{in}^3 = 116\text{ kip-ft}$$

$$\sigma_{\text{crushing}} = 7.0\text{ ksi} \quad \rightarrow \quad P_{\text{crushing}} = \sigma_{\text{crushing}} \cdot A_{\text{base}} = 7\text{ksi} \cdot 88.1\text{in}^2 = 616.7\text{ kips}$$

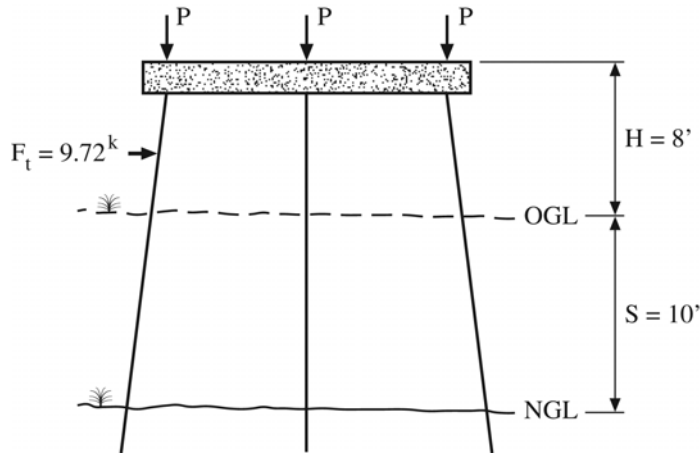
Therefore section is controlled by buckling, not crushing. Finally, apply interaction equation.

$$\frac{P_{\text{axial}}}{P_{\text{cr}}} + \frac{M_{\text{Max}}}{M_{\text{rupture}}} = \frac{60\text{ kips}}{164\text{ kips}} + \frac{38.1\text{ kip-ft}}{116\text{ kip-ft}} = 0.37 + 0.33 = 0.70 < 0.75 \rightarrow \text{OK! for } P \leq 60\text{ kips}$$

Therefore, all P-loads for a 14in pile will be adequate as well.



For the following unbraced bent geometry:  $H = 8$  ft,  $S = 10$  ft, 3-Pile Bent,  $F_t = 9.72$  kips



At the location of effective section, 5.58 ft above NGL as shown in figure, with a 12in pile:

$$d_{\text{eff}} = 12\text{in} - (11.17\text{ft} \cdot 0.12 \frac{\text{in}}{\text{ft}}) = 10.66\text{ in}$$

$$I_{\text{eff}} = \frac{\pi \cdot (10.66\text{in})^4}{64} = 633.8\text{ in}^4$$

$$A_{\text{eff}} = \frac{\pi \cdot (10.66\text{in})^2}{4} = 89.2\text{ in}^2$$

$$S_{\text{eff}} = \frac{\pi \cdot (10.66\text{in})^3}{32} = 118.9\text{ in}^3$$

Determine  $P_{\text{cr}}$  for buckling :

$$P_{\text{cr}} = \frac{0.25 \cdot \pi^2 \cdot E \cdot I_{\text{eff}}}{L^2} = \frac{0.25 \cdot \pi^2 \cdot 1800\text{ksi} \cdot 633.8\text{in}^4}{(16.75\text{ft} \cdot 12)^2} = 69.7\text{ kips} \rightarrow \text{OK! for } P \leq 60\text{ kips in buckling}$$

Check at interaction equation at base (smallest section, therefore most critical):

$$d_{\text{base}} = 12\text{in} - (16.75\text{ft} \cdot 0.12 \frac{\text{in}}{\text{ft}}) = 9.99\text{ in}$$

$$I_{\text{base}} = \frac{\pi \cdot (9.99\text{in})^4}{64} = 488\text{ in}^4$$

$$A_{\text{base}} = \frac{\pi \cdot (9.99\text{in})^2}{4} = 78.3\text{ in}^2$$

$$S_{\text{base}} = \frac{\pi \cdot (9.99\text{in})^3}{32} = 97.8\text{ in}^3$$

Recall,

$$\sigma_{\text{rupture}} = 12.0\text{ ksi} \quad \rightarrow \quad M_{\text{rupture}} = \sigma_{\text{rupture}} \cdot S_{\text{base}} = 12\text{ksi} \cdot 97.8 \cdot \text{in}^3 = 97.8\text{ kip-ft}$$

$$\sigma_{\text{crushing}} = 7.0\text{ ksi} \quad \rightarrow \quad P_{\text{crushing}} = \sigma_{\text{crushing}} \cdot A_{\text{base}} = 7\text{ksi} \cdot 78.3 \cdot \text{in}^2 = 548.1\text{ kips}$$

Therefore section is controlled by buckling, rather than crushing.

Finally, by applying the interaction equation:

$$\frac{P_{axial}}{P_{cr}} + \frac{M_{Max}}{M_{rupture}} = \frac{60 \cdot \text{kips}}{69.7 \cdot \text{kips}} + \frac{54.3 \cdot \text{kip} \cdot \text{ft}}{97.8 \cdot \text{kip} \cdot \text{ft}} = 0.86 + 0.56 = 1.42 > 0.75 \rightarrow \text{No Good! for } P = 60^k$$

Try  $P = 40$  kips:

$$\frac{P_{axial}}{P_{cr}} + \frac{M_{Max}}{M_{rupture}} = \frac{40 \cdot \text{kips}}{69.7 \cdot \text{kips}} + \frac{54.3 \cdot \text{kip} \cdot \text{ft}}{97.8 \cdot \text{kip} \cdot \text{ft}} = 0.57 + 0.56 = 1.13 > 0.75 \rightarrow \text{No Good! for } P = 40^k$$

Try  $P = 20$  kips:

$$\frac{P_{axial}}{P_{cr}} + \frac{M_{Max}}{M_{rupture}} = \frac{20 \cdot \text{kips}}{69.7 \cdot \text{kips}} + \frac{54.3 \cdot \text{kip} \cdot \text{ft}}{97.8 \cdot \text{kip} \cdot \text{ft}} = 0.29 + 0.56 = 0.85 > 0.75 \rightarrow \text{No Good! for } P = 20^k$$

Checking again with a 14in pile:

$$d_{eff} = 14\text{in} - (11.17\text{ft} \cdot 0.12 \frac{\text{in}}{\text{ft}}) = 12.66 \text{ in} \quad I_{eff} = \frac{\pi \cdot (12.66\text{in})^4}{64} = 1260 \text{ in}^4$$

Determine  $P_{cr}$  for buckling :

$$P_{cr} = \frac{0.25 \cdot \pi^2 \cdot E \cdot I_{eff}}{L^2} = \frac{0.25 \cdot \pi^2 \cdot 1800\text{ksi} \cdot 1260\text{in}^4}{(16.75\text{ft} \cdot 12)^2} = 138.5 \text{ kips} \rightarrow \text{OK! for } P \leq 60 \text{ kips in buckling}$$

Check interaction equation at base (smallest section, therefore most critical):

$$d_{base} = 14\text{in} - (16.75\text{ft} \cdot 0.12 \frac{\text{in}}{\text{ft}}) = 11.99 \text{ in} \quad I_{base} = \frac{\pi \cdot (11.99\text{in})^4}{64} = 1014 \text{ in}^4$$

$$A_{base} = \frac{\pi \cdot (11.99\text{in})^2}{4} = 112.9 \text{ in}^2 \quad S_{base} = \frac{\pi \cdot (11.99\text{in})^3}{32} = 169.2\text{in}^3$$

Recall,

$$\sigma_{rupture} = 12.0 \text{ ksi} \quad \rightarrow \quad M_{rupture} = \sigma_{rupture} \cdot S_{base} = 12\text{ksi} \cdot 169.2 \cdot \text{in}^3 = 169.2 \text{ kip-ft}$$

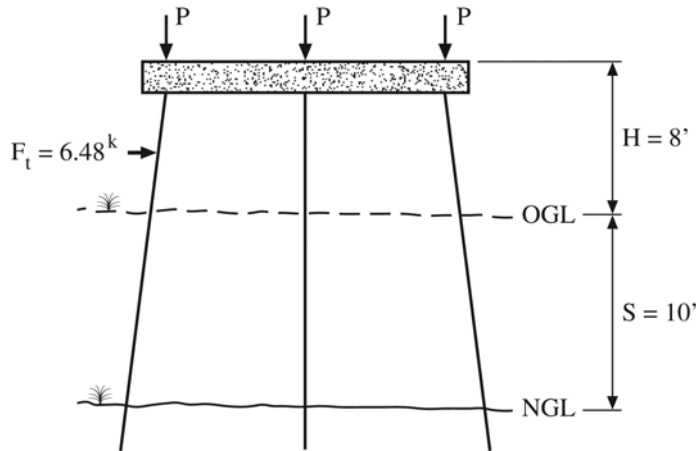
$$\sigma_{crushing} = 7.0 \text{ ksi} \quad \rightarrow \quad P_{crushing} = \sigma_{crushing} \cdot A_{base} = 7\text{ksi} \cdot 112.9 \cdot \text{in}^2 = 790.3 \text{ kips}$$

Therefore section is controlled by buckling, rather than crushing.

Finally, by applying the interaction equation:

$$\frac{P_{axial}}{P_{cr}} + \frac{M_{Max}}{M_{rupture}} = \frac{60 \cdot \text{kips}}{138.5 \cdot \text{kips}} + \frac{54.3 \cdot \text{kip} \cdot \text{ft}}{169.2 \cdot \text{kip} \cdot \text{ft}} = 0.43 + 0.32 = 0.75 \rightarrow \text{OK! for } P \leq 60^k$$

For the following unbraced bent geometry:  $H = 8$  ft,  $S = 10$  ft, 3-Pile Bent,  $F_t = 6.48$  kips



At the location of effective section, 5.58 ft above NGL as shown in figure, with a 12in pile:

$$d_{\text{eff}} = 12\text{in} - \left(11.17\text{ft} \cdot 0.12 \frac{\text{in}}{\text{ft}}\right) = 10.66\text{ in} \quad I_{\text{eff}} = \frac{\pi \cdot (10.66\text{in})^4}{64} = 633.8\text{ in}^4$$

Determine  $P_{\text{cr}}$  for buckling :

$$P_{\text{cr}} = \frac{0.25 \cdot \pi^2 \cdot E \cdot I_{\text{eff}}}{L^2} = \frac{0.25 \cdot \pi^2 \cdot 1800\text{ksi} \cdot 633.8\text{in}^4}{(16.75\text{ft} \cdot 12)^2} = 69.7\text{ kips}$$

Check at interaction equation at base (smallest section, therefore most critical):

$$d_{\text{base}} = 12\text{in} - \left(16.75\text{ft} \cdot 0.12 \frac{\text{in}}{\text{ft}}\right) = 9.99\text{ in} \quad I_{\text{base}} = \frac{\pi \cdot (9.99\text{in})^4}{64} = 488\text{ in}^4$$

$$A_{\text{base}} = \frac{\pi \cdot (9.99\text{in})^2}{4} = 78.3\text{ in}^2 \quad S_{\text{base}} = \frac{\pi \cdot (9.99\text{in})^3}{32} = 97.8\text{ in}^3$$

Recall,

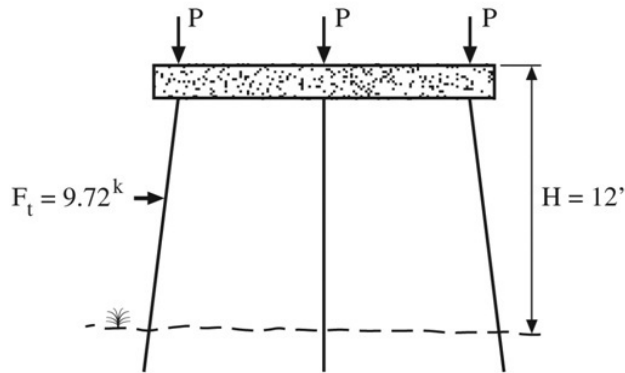
$$\sigma_{\text{rupture}} = 12.0\text{ ksi} \quad \rightarrow M_{\text{rupture}} = \sigma_{\text{rupture}} \cdot S_{\text{base}} = 12\text{ksi} \cdot 97.8 \cdot \text{in}^3 = 97.8\text{ kip}\cdot\text{ft}$$

$$\sigma_{\text{crushing}} = 7.0\text{ ksi} \quad \rightarrow P_{\text{crushing}} = \sigma_{\text{crushing}} \cdot A_{\text{base}} = 7\text{ksi} \cdot 78.3 \cdot \text{in}^2 = 548.1\text{ kips}$$

Determine maximum P value where interaction equation = 0.75:

$$\frac{P_{\text{axial}}}{P_{\text{cr}}} + \frac{M_{\text{Max}}}{M_{\text{rupture}}} = \frac{P_{\text{max}}}{69.7 \cdot \text{kips}} + \frac{36.2 \cdot \text{kip} \cdot \text{ft}}{97.8 \cdot \text{kip} \cdot \text{ft}} = 0.38 + 0.37 = 0.75 \rightarrow P_{\text{max}} = 26\text{ kips}$$

For the following unbraced bent geometry:  $H = 12$  ft,  $S = 0$  ft, 3-Pile Bent,  $F_t = 9.27$  kips



At the location of effective section, 3.58 ft above NGL as shown in figure, with a 12in pile:

$$d_{\text{eff}} = 12\text{in} - \left(7.17\text{ft} \cdot 0.12 \frac{\text{in}}{\text{ft}}\right) = 11.1\text{ in} \qquad I_{\text{eff}} = \frac{\pi \cdot (11.1\text{in})^4}{64} = 745.2\text{ in}^4$$

Determine  $P_{\text{cr}}$  for buckling :

$$P_{\text{cr}} = \frac{0.25 \cdot \pi^2 \cdot E \cdot I_{\text{eff}}}{L^2} = \frac{0.25 \cdot \pi^2 \cdot 1800\text{ksi} \cdot 745.2\text{in}^4}{(10.75\text{ft} \cdot 12)^2} = 198\text{ kips} \rightarrow \text{OK! for } P \leq 60\text{ kips in buckling}$$

Check at interaction equation at base (smallest section, therefore most critical):

$$d_{\text{base}} = 12\text{in} - \left(10.75\text{ft} \cdot 0.12 \frac{\text{in}}{\text{ft}}\right) = 9.74\text{ in} \qquad I_{\text{base}} = \frac{\pi \cdot (9.74\text{in})^4}{64} = 441.7\text{ in}^4$$

$$A_{\text{base}} = \frac{\pi \cdot (9.74\text{in})^2}{4} = 74.5\text{ in}^2 \qquad S_{\text{base}} = \frac{\pi \cdot (9.74\text{in})^3}{32} = 90.7\text{in}^3$$

Recall,

$$\sigma_{\text{rupture}} = 12.0\text{ ksi} \qquad \rightarrow M_{\text{rupture}} = \sigma_{\text{rupture}} \cdot S_{\text{base}} = 12\text{ksi} \cdot 90.7 \cdot \text{in}^3 = 90.7\text{ kip}\cdot\text{ft}$$

$$\sigma_{\text{crushing}} = 7.0\text{ ksi} \qquad \rightarrow P_{\text{crushing}} = \sigma_{\text{crushing}} \cdot A_{\text{base}} = 7\text{ksi} \cdot 74.5 \cdot \text{in}^2 = 521.5\text{ kips}$$

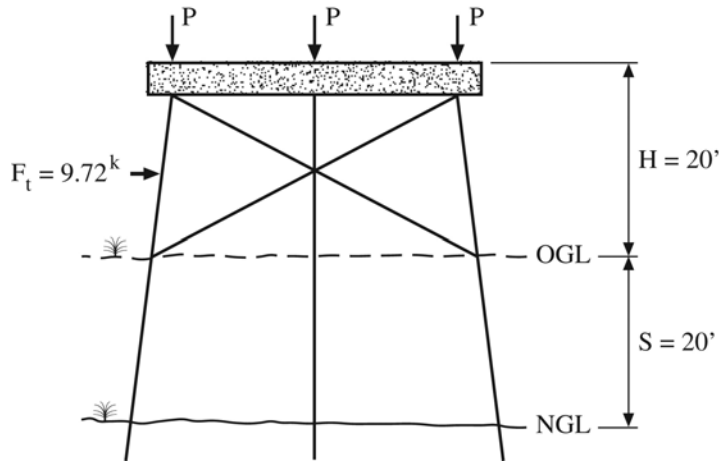
Therefore section is controlled by buckling, rather than crushing.

Finally, by applying the interaction equation:

$$\frac{P_{\text{axial}}}{P_{\text{cr}}} + \frac{M_{\text{Max}}}{M_{\text{rupture}}} = \frac{60 \cdot \text{kips}}{198 \cdot \text{kips}} + \frac{34.8 \cdot \text{kip} \cdot \text{ft}}{90.7 \cdot \text{kip} \cdot \text{ft}} = 0.31 + 0.38 = 0.69 < 0.75 \rightarrow \text{OK! for } P \leq 60\text{ kips}$$

Therefore, 14in diameter pile will also be safe for all P-loads.

For the following unbraced bent geometry:  $H = 12$  ft,  $S = 5$  ft, 3-Pile Bent,  $F_t = 9.27$  kips



At the location of effective section, 5.25 ft above NGL as shown in figure, with a 12in pile:

$$d_{\text{eff}} = 12\text{in} - (10.50\text{ft} \cdot 0.12 \frac{\text{in}}{\text{ft}}) = 10.74\text{ in} \qquad I_{\text{eff}} = \frac{\pi \cdot (10.74\text{in})^4}{64} = 653.1\text{ in}^4$$

$$A_{\text{eff}} = \frac{\pi \cdot (10.74\text{in})^2}{4} = 90.6\text{ in}^2 \qquad S_{\text{eff}} = \frac{\pi \cdot (10.74\text{in})^3}{32} = 121.6\text{ in}^3$$

Determine  $P_{\text{cr}}$  for buckling :

$$P_{\text{cr}} = \frac{0.25 \cdot \pi^2 \cdot E \cdot I_{\text{eff}}}{L^2} = \frac{0.25 \cdot \pi^2 \cdot 1800\text{ksi} \cdot 653.1\text{in}^4}{(15.75\text{ft} \cdot 12)^2} = 81.2\text{ kips} \rightarrow \text{OK! for } P \leq 60\text{ kips in buckling}$$

Check at interaction equation at base (smallest section, therefore most critical):

$$d_{\text{base}} = 12\text{in} - (15.75\text{ft} \cdot 0.12 \frac{\text{in}}{\text{ft}}) = 10.1\text{ in} \qquad I_{\text{base}} = \frac{\pi \cdot (10.1\text{in})^4}{64} = 510.8\text{ in}^4$$

$$A_{\text{base}} = \frac{\pi \cdot (10.1\text{in})^2}{4} = 80.1\text{ in}^2 \qquad S_{\text{base}} = \frac{\pi \cdot (10.1\text{in})^3}{32} = 101.1\text{ in}^3$$

Recall,

$$\sigma_{\text{rupture}} = 12.0\text{ ksi} \qquad \rightarrow M_{\text{rupture}} = \sigma_{\text{rupture}} \cdot S_{\text{base}} = 12\text{ksi} \cdot 101.1 \cdot \text{in}^3 = 101.1\text{ kip-ft}$$

$$\sigma_{\text{crushing}} = 7.0\text{ ksi} \qquad \rightarrow P_{\text{crushing}} = \sigma_{\text{crushing}} \cdot A_{\text{base}} = 7\text{ksi} \cdot 80.1 \cdot \text{in}^2 = 560.7\text{ kips}$$

Therefore section is controlled by buckling, rather than crushing.

Finally, by applying the interaction equation:

$$\frac{P_{axial}}{P_{cr}} + \frac{M_{Max}}{M_{rupture}} = \frac{60 \cdot \text{kips}}{81.2 \cdot \text{kips}} + \frac{51.0 \cdot \text{kip} \cdot \text{ft}}{101.3 \cdot \text{kip} \cdot \text{ft}} = 0.74 + 0.50 = 1.24 > 0.75 \rightarrow \text{NG! for } P = 60 \text{ kips}$$

Try P = 40 kips:

$$\frac{P_{axial}}{P_{cr}} + \frac{M_{Max}}{M_{rupture}} = \frac{40 \cdot \text{kips}}{81.2 \cdot \text{kips}} + \frac{51.0 \cdot \text{kip} \cdot \text{ft}}{101.3 \cdot \text{kip} \cdot \text{ft}} = 0.49 + 0.50 = 0.99 > 0.75 \rightarrow \text{NG! for } P = 40 \text{ kips}$$

Try P = 20 kips:

$$\frac{P_{axial}}{P_{cr}} + \frac{M_{Max}}{M_{rupture}} = \frac{20 \cdot \text{kips}}{81.2 \cdot \text{kips}} + \frac{51.0 \cdot \text{kip} \cdot \text{ft}}{101.3 \cdot \text{kip} \cdot \text{ft}} = 0.25 + 0.50 = 0.75 \rightarrow \text{OK! for } P = 20 \text{ kips}$$

Check P = 40, 60 kips for 14in diameter pile. (20 kips P-load will be okay by inspection.)

At the location of effective section, 5.25 ft above NGL as shown in figure, with a 14in pile:

$$d_{eff} = 14\text{in} - (10.50\text{ft} \cdot 0.12 \frac{\text{in}}{\text{ft}}) = 12.74 \text{ in} \quad I_{eff} = \frac{\pi \cdot (12.74\text{in})^4}{64} = 1293 \text{ in}^4$$

Determine  $P_{cr}$  for buckling :

$$P_{cr} = \frac{0.25 \cdot \pi^2 \cdot E \cdot I_{eff}}{L^2} = \frac{0.25 \cdot \pi^2 \cdot 1800\text{ksi} \cdot 1293\text{in}^4}{(15.75\text{ft} \cdot 12)^2} = 160.7 \text{ kips} \rightarrow \text{OK! for } P \leq 60 \text{ kips in buckling}$$

Check at interaction equation at base (smallest section, therefore most critical):

$$d_{base} = 14\text{in} - (15.75\text{ft} \cdot 0.12 \frac{\text{in}}{\text{ft}}) = 12.1 \text{ in} \quad I_{base} = \frac{\pi \cdot (12.1\text{in})^4}{64} = 1052 \text{ in}^4$$

$$A_{base} = \frac{\pi \cdot (12.1\text{in})^2}{4} = 114 \text{ in}^2 \quad S_{base} = \frac{\pi \cdot (12.1\text{in})^3}{32} = 173 \text{ in}^3$$

$$\sigma_{rupture} = 12.0 \text{ ksi} \quad \rightarrow \quad M_{rupture} = \sigma_{rupture} \cdot S_{base} = 12\text{ksi} \cdot 173 \cdot \text{in}^3 = 173 \text{ kip-ft}$$

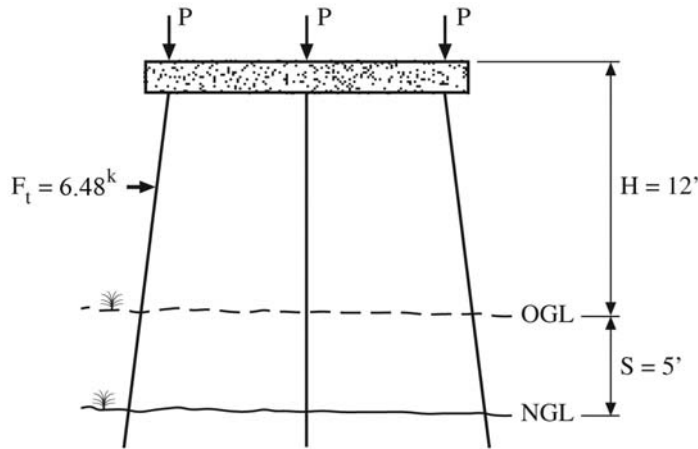
$$\sigma_{crushing} = 7.0 \text{ ksi} \quad \rightarrow \quad P_{crushing} = \sigma_{crushing} \cdot A_{base} = 7\text{ksi} \cdot 114 \cdot \text{in}^2 = 798 \text{ kips}$$

Therefore section is controlled by buckling, rather than crushing.

Finally, by applying the interaction equation:

$$\frac{P_{axial}}{P_{cr}} + \frac{M_{Max}}{M_{rupture}} = \frac{60 \cdot \text{kips}}{160.7 \cdot \text{kips}} + \frac{51.0 \cdot \text{kip} \cdot \text{ft}}{173 \cdot \text{kip} \cdot \text{ft}} = 0.37 + 0.29 = 0.66 < 0.75 \rightarrow \text{OK! for } P \leq 60 \text{ kips}$$

For the following unbraced bent geometry:  $H = 12$  ft,  $S = 5$  ft, 3-Pile Bent,  $F_t = 6.48$  kips



At the location of effective section, 5.25 ft above NGL as shown in figure, with a 12in pile:

$$d_{\text{eff}} = 12\text{in} - (10.50\text{ft} \cdot 0.12 \frac{\text{in}}{\text{ft}}) = 10.74 \text{ in} \quad I_{\text{eff}} = \frac{\pi \cdot (10.74\text{in})^4}{64} = 653.1 \text{ in}^4$$

$$A_{\text{eff}} = \frac{\pi \cdot (10.74\text{in})^2}{4} = 90.6 \text{ in}^2 \quad S_{\text{eff}} = \frac{\pi \cdot (10.74\text{in})^3}{32} = 121.6 \text{ in}^3$$

Recall  $P_{\text{cr}}$  for buckling :

$$P_{\text{cr}} = \frac{0.25 \cdot \pi^2 \cdot E \cdot I_{\text{eff}}}{L^2} = \frac{0.25 \cdot \pi^2 \cdot 1800\text{ksi} \cdot 653.1\text{in}^4}{(15.75\text{ft} \cdot 12)^2} = 81.2 \text{ kips}$$

Check at interaction equation at base (smallest section, therefore most critical):

$$d_{\text{base}} = 12\text{in} - (15.75\text{ft} \cdot 0.12 \frac{\text{in}}{\text{ft}}) = 10.1 \text{ in} \quad I_{\text{base}} = \frac{\pi \cdot (10.1\text{in})^4}{64} = 510.8 \text{ in}^4$$

$$A_{\text{base}} = \frac{\pi \cdot (10.1\text{in})^2}{4} = 80.1 \text{ in}^2 \quad S_{\text{base}} = \frac{\pi \cdot (10.1\text{in})^3}{32} = 101.1\text{in}^3$$

Recall,

$$\sigma_{\text{rupture}} = 12.0 \text{ ksi} \quad \rightarrow \quad M_{\text{rupture}} = \sigma_{\text{rupture}} \cdot S_{\text{base}} = 12\text{ksi} \cdot 101.1 \cdot \text{in}^3 = 101.1 \text{ kip}\cdot\text{ft}$$

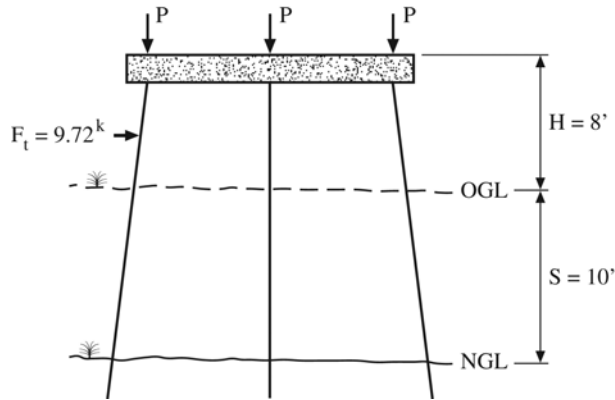
$$\sigma_{\text{crushing}} = 7.0 \text{ ksi} \quad \rightarrow \quad P_{\text{crushing}} = \sigma_{\text{crushing}} \cdot A_{\text{base}} = 7\text{ksi} \cdot 80.1 \cdot \text{in}^2 = 560.7 \text{ kips}$$

Therefore section is controlled by buckling, rather than crushing.

Finally, by applying the interaction equation:

$$\frac{P_{\text{axial}}}{P_{\text{cr}}} + \frac{M_{\text{Max}}}{M_{\text{rupture}}} = \frac{P_{\text{max}}}{81.2 \cdot \text{kips}} + \frac{35.6 \cdot \text{kip} \cdot \text{ft}}{101.3 \cdot \text{kip} \cdot \text{ft}} = 0.40 + 0.35 = 0.75 \rightarrow P_{\text{max}} = 32 \text{ kips}$$

For the following unbraced bent geometry:  $H = 12$  ft,  $S = 10$  ft, 3-Pile Bent,  $F_t = 9.27$  kips



At the location of effective section, 6.92 ft above NGL as shown in figure, with a 12in pile:

$$d_{\text{eff}} = 12\text{in} - (13.83\text{ft} \cdot 0.12 \frac{\text{in}}{\text{ft}}) = 10.3 \text{ in} \quad I_{\text{eff}} = \frac{\pi \cdot (10.3\text{in})^4}{64} = 552.5 \text{ in}^4$$

Determine  $P_{\text{cr}}$  for buckling :

$$P_{\text{cr}} = \frac{0.25 \cdot \pi^2 \cdot E \cdot I_{\text{eff}}}{L^2} = \frac{0.25 \cdot \pi^2 \cdot 1800\text{ksi} \cdot 552.5\text{in}^4}{(20.75\text{ft} \cdot 12)^2} = 39.6 \text{ kips} \rightarrow \text{No Good! for } P = 40, 60 \text{ kips}$$

Do not need to check rupture or interaction equation since fails in buckling.

Check  $P = 20$  kips for 12in diameter pile (40 kip load will be inadequate in buckling alone):

$$d_{\text{base}} = 12\text{in} - (20.75\text{ft} \cdot 0.12 \frac{\text{in}}{\text{ft}}) = 9.51 \text{ in} \quad I_{\text{base}} = \frac{\pi \cdot (9.51\text{in})^4}{64} = 104.5 \text{ in}^4$$

$$A_{\text{base}} = \frac{\pi \cdot (9.51\text{in})^2}{4} = 71.03 \text{ in}^2 \quad S_{\text{base}} = \frac{\pi \cdot (9.51\text{in})^3}{32} = 84.4\text{in}^3$$

Recall,

$$\sigma_{\text{rupture}} = 12.0 \text{ ksi} \quad \rightarrow \quad M_{\text{rupture}} = \sigma_{\text{rupture}} \cdot S_{\text{base}} = 12\text{ksi} \cdot 84.4 \cdot \text{in}^3 = 84.4 \text{ kip-ft}$$

$$\sigma_{\text{crushing}} = 7.0 \text{ ksi} \quad \rightarrow \quad P_{\text{crushing}} = \sigma_{\text{crushing}} \cdot A_{\text{base}} = 7\text{ksi} \cdot 71.03 \cdot \text{in}^2 = 497.2 \text{ kips}$$

Therefore section is controlled by buckling, rather than crushing.

Finally, by applying the interaction equation:

$$\frac{P_{\text{axial}}}{P_{\text{cr}}} + \frac{M_{\text{Max}}}{M_{\text{rupture}}} = \frac{20 \cdot \text{kips}}{39.6 \cdot \text{kips}} + \frac{45.4 \cdot \text{kip} \cdot \text{ft}}{84.4 \cdot \text{kip} \cdot \text{ft}} = 0.51 + 0.54 = 1.05 > 0.75 \rightarrow \text{No Good!}$$

for  $P = 20$  kips



Determine maximum value of P for interaction equation = 0.75:

$$\frac{P_{\text{axial}}}{P_{\text{cr}}} + \frac{M_{\text{Max}}}{M_{\text{rupture}}} = \frac{P_{\text{max}}}{39.6 \cdot \text{kips}} + \frac{45.4 \cdot \text{kip} \cdot \text{ft}}{84.4 \cdot \text{kip} \cdot \text{ft}} = 0.21 + 0.54 = 0.75 \rightarrow P_{\text{max}} = 8.3 \text{ kips}$$

Checking again while assuming a 14in pile instead:

$$d_{\text{eff}} = 14\text{in} - \left(17.17\text{ft} \cdot 0.12 \frac{\text{in}}{\text{ft}}\right) = 12.34 \text{ in} \quad I_{\text{eff}} = \frac{\pi \cdot (12.34\text{in})^4}{64} = 1138 \text{ in}^4$$

$$A_{\text{eff}} = \frac{\pi \cdot (12.34\text{in})^2}{4} = 119.6 \text{ in}^2 \quad S_{\text{eff}} = \frac{\pi \cdot (12.34\text{in})^3}{32} = 184.5 \text{ in}^3$$

Determine  $P_{\text{cr}}$  for buckling :

$$P_{\text{cr}} = \frac{0.25 \cdot \pi^2 \cdot E \cdot I_{\text{eff}}}{L^2} = \frac{0.25 \cdot \pi^2 \cdot 1800\text{ksi} \cdot 1138\text{in}^4}{(20.75\text{ft} \cdot 12)^2} = 81.6 \text{ kips} \rightarrow \text{OK! for all P-loads in buckling}$$

Check at interaction equation at base (smallest section, therefore most critical):

$$d_{\text{base}} = 14\text{in} - \left(20.75\text{ft} \cdot 0.12 \frac{\text{in}}{\text{ft}}\right) = 11.51 \text{ in} \quad I_{\text{base}} = \frac{\pi \cdot (11.51\text{in})^4}{64} = 861.5 \text{ in}^4$$

$$A_{\text{base}} = \frac{\pi \cdot (11.51\text{in})^2}{4} = 104 \text{ in}^2 \quad S_{\text{base}} = \frac{\pi \cdot (11.51\text{in})^3}{32} = 149.7 \text{ in}^3$$

Recall,

$$\sigma_{\text{rupture}} = 12.0 \text{ ksi} \quad \rightarrow M_{\text{rupture}} = \sigma_{\text{rupture}} \cdot S_{\text{base}} = 12\text{ksi} \cdot 149.7 \cdot \text{in}^3 = 149.7 \text{ kip-ft}$$

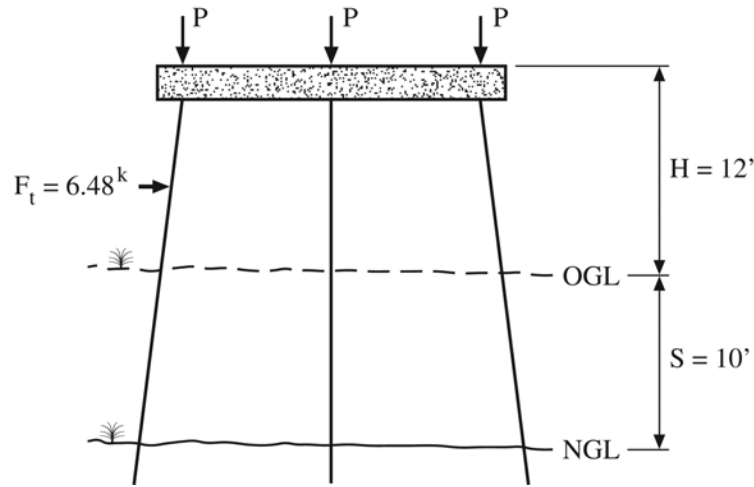
$$\sigma_{\text{crushing}} = 7.0 \text{ ksi} \quad \rightarrow P_{\text{crushing}} = \sigma_{\text{crushing}} \cdot A_{\text{base}} = 7\text{ksi} \cdot 104 \cdot \text{in}^2 = 728 \text{ kips}$$

Therefore section is controlled by buckling, rather than crushing.

Finally, by applying the interaction equation to determine maximum load:

$$\frac{P_{\text{axial}}}{P_{\text{cr}}} + \frac{M_{\text{Max}}}{M_{\text{rupture}}} = \frac{P_{\text{max}}}{81.6 \cdot \text{kips}} + \frac{45.4 \cdot \text{kip} \cdot \text{ft}}{149.7 \cdot \text{kip} \cdot \text{ft}} = 0.45 + 0.30 = 0.75 \rightarrow P_{\text{max}} = 36 \text{ kips}$$

For the following unbraced bent geometry:  $H = 12$  ft,  $S = 10$  ft, 3-Pile Bent,  $F_t = 6.48$  kips



Check  $P = 20$  kips for 12in diameter pile for smaller raft:

Recall,

$$P_{cr} = \frac{0.25 \cdot \pi^2 \cdot E \cdot I_{eff}}{L^2} = \frac{0.25 \cdot \pi^2 \cdot 1800 \text{ksi} \cdot 552.5 \text{in}^4}{(20.75 \text{ft} \cdot 12)^2} = 39.6 \text{ kips}$$

$$d_{base} = 12 \text{in} - (20.75 \text{ft} \cdot 0.12 \frac{\text{in}}{\text{ft}}) = 9.51 \text{in} \quad I_{base} = \frac{\pi \cdot (9.51 \text{in})^4}{64} = 104.5 \text{in}^4$$

$$A_{base} = \frac{\pi \cdot (9.51 \text{in})^2}{4} = 71.03 \text{in}^2 \quad S_{base} = \frac{\pi \cdot (9.51 \text{in})^3}{32} = 84.4 \text{in}^3$$

$$\sigma_{rupture} = 12.0 \text{ ksi} \quad \rightarrow \quad M_{rupture} = \sigma_{rupture} \cdot S_{base} = 12 \text{ksi} \cdot 84.4 \cdot \text{in}^3 = 84.4 \text{ kip-ft}$$

$$\sigma_{crushing} = 7.0 \text{ ksi} \quad \rightarrow \quad P_{crushing} = \sigma_{crushing} \cdot A_{base} = 7 \text{ksi} \cdot 71.03 \cdot \text{in}^2 = 497.2 \text{ kips}$$

Finally, by applying the interaction equation:

$$\frac{P_{axial}}{P_{cr}} + \frac{M_{Max}}{M_{rupture}} = \frac{20 \cdot \text{kips}}{39.6 \cdot \text{kips}} + \frac{30.3 \cdot \text{kip} \cdot \text{ft}}{84.4 \cdot \text{kip} \cdot \text{ft}} = 0.51 + 0.36 = 0.87 > 0.75 \rightarrow \text{NG! for } P = 20 \text{ kips}$$

Only need to check  $P = 40, 60$  kips for the smaller raft for 14in diameter piles. Recall,

$$A_{eff} = \frac{\pi \cdot (12.34 \text{in})^2}{4} = 119.6 \text{in}^2$$

$$P_{cr} = \frac{0.25 \cdot \pi^2 \cdot E \cdot I_{eff}}{L^2} = \frac{0.25 \cdot \pi^2 \cdot 1800 \text{ksi} \cdot 1138 \text{in}^4}{(20.75 \text{ft} \cdot 12)^2} = 81.6 \text{ kips}$$

Check interaction equation at base (smallest section, therefore most critical):

$$d_{base} = 14 \text{in} - (20.75 \text{ft} \cdot 0.12 \frac{\text{in}}{\text{ft}}) = 11.51 \text{ in} \quad I_{base} = \frac{\pi \cdot (11.51 \text{in})^4}{64} = 861.5 \text{ in}^4$$

$$A_{base} = \frac{\pi \cdot (11.51 \text{in})^2}{4} = 104 \text{ in}^2 \quad S_{base} = \frac{\pi \cdot (11.51 \text{in})^3}{32} = 149.7 \text{ in}^3$$

$$\sigma_{rupture} = 12.0 \text{ ksi} \quad \rightarrow M_{rupture} = \sigma_{rupture} \cdot S_{base} = 12 \text{ksi} \cdot 149.7 \cdot \text{in}^3 = 1796.4 \text{ kip}\cdot\text{ft}$$

$$\sigma_{crushing} = 7.0 \text{ ksi} \quad \rightarrow P_{crushing} = \sigma_{crushing} \cdot A_{base} = 7 \text{ksi} \cdot 104 \cdot \text{in}^2 = 728 \text{ kips}$$

Finally, by applying the interaction equation:

$$\frac{P_{axial}}{P_{cr}} + \frac{M_{Max}}{M_{rupture}} = \frac{60 \cdot \text{kips}}{81.6 \cdot \text{kips}} + \frac{30.3 \cdot \text{kip} \cdot \text{ft}}{1796.4 \cdot \text{kip} \cdot \text{ft}} = 0.74 + 0.20 = 0.94 > 0.75 \rightarrow \text{NG! for } P = 60 \text{ kips}$$

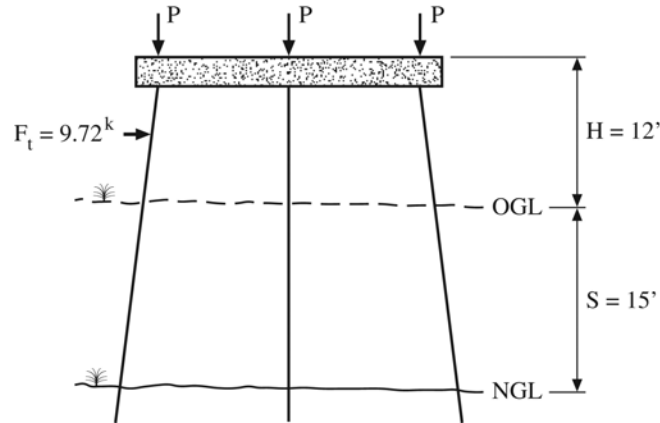
Try  $P = 40$  kips:

$$\frac{P_{axial}}{P_{cr}} + \frac{M_{Max}}{M_{rupture}} = \frac{40 \cdot \text{kips}}{81.6 \cdot \text{kips}} + \frac{30.3 \cdot \text{kip} \cdot \text{ft}}{1796.4 \cdot \text{kip} \cdot \text{ft}} = 0.49 + 0.20 = 0.69 < 0.75 \rightarrow \text{OK! for } P = 40 \text{ kips}$$

Determine maximum value of  $P$ :

$$\frac{P_{axial}}{P_{cr}} + \frac{M_{Max}}{M_{rupture}} = \frac{P_{max}}{81.6 \cdot \text{kips}} + \frac{30.3 \cdot \text{kip} \cdot \text{ft}}{1796.4 \cdot \text{kip} \cdot \text{ft}} = 0.55 + 0.20 = 0.75 \rightarrow P_{max} = 44 \text{ kips}$$

For the following unbraced bent geometry:  $H = 12$  ft,  $S = 15$  ft, 3-Pile Bent,  $F_t = 9.27$  kips



At the location of effective section, 8.58 ft above NGL as shown in figure, with a 12in pile:

$$d_{\text{eff}} = 12\text{in} - (17.17\text{ft} \cdot 0.12 \frac{\text{in}}{\text{ft}}) = 9.94 \text{ in} \quad I_{\text{eff}} = \frac{\pi \cdot (8.90\text{in})^4}{64} = 479.2 \text{ in}^4$$

Determine  $P_{\text{cr}}$  for buckling :

$$P_{\text{cr}} = \frac{0.25 \cdot \pi^2 \cdot E \cdot I_{\text{eff}}}{L^2} = \frac{0.25 \cdot \pi^2 \cdot 1800\text{ksi} \cdot 479.2\text{in}^4}{(25.75\text{ft} \cdot 12)^2} = 22.3 \text{ kips} \rightarrow \text{No Good! for } P \leq 60 \text{ kips}$$

By inspection, it will fail for all P-load levels (including  $P = 20$  kips after effects of interaction).

Checking again while assuming a 14in pile instead:

$$d_{\text{eff}} = 14\text{in} - (17.17\text{ft} \cdot 0.12 \frac{\text{in}}{\text{ft}}) = 11.84 \text{ in} \quad I_{\text{eff}} = \frac{\pi \cdot (11.84\text{in})^4}{64} = 964.7 \text{ in}^4$$

Determine  $P_{\text{cr}}$  for buckling :

$$P_{\text{cr}} = \frac{0.25 \cdot \pi^2 \cdot E \cdot I_{\text{eff}}}{L^2} = \frac{0.25 \cdot \pi^2 \cdot 1800\text{ksi} \cdot 964\text{in}^4}{(25.75\text{ft} \cdot 12)^2} = 44.8 \text{ kips} \rightarrow \text{No Good! for } P = 40, 60 \text{ kips}$$

Check at interaction equation at base (smallest section, therefore most critical):

$$d_{\text{base}} = 14\text{in} - (25.75\text{ft} \cdot 0.12 \frac{\text{in}}{\text{ft}}) = 10.91 \text{ in} \quad I_{\text{base}} = \frac{\pi \cdot (10.91\text{in})^4}{64} = 695.4 \text{ in}^4$$

$$A_{\text{base}} = \frac{\pi \cdot (10.91\text{in})^2}{4} = 93.5 \text{ in}^2 \quad S_{\text{base}} = \frac{\pi \cdot (10.91\text{in})^3}{32} = 127.9\text{in}^3$$

Recall,

$$\sigma_{\text{rupture}} = 12.0 \text{ ksi} \quad \rightarrow \quad M_{\text{rupture}} = \sigma_{\text{rupture}} \cdot S_{\text{base}} = 12 \text{ ksi} \cdot 127.9 \cdot \text{in}^3 = 127.9 \text{ kip-ft}$$

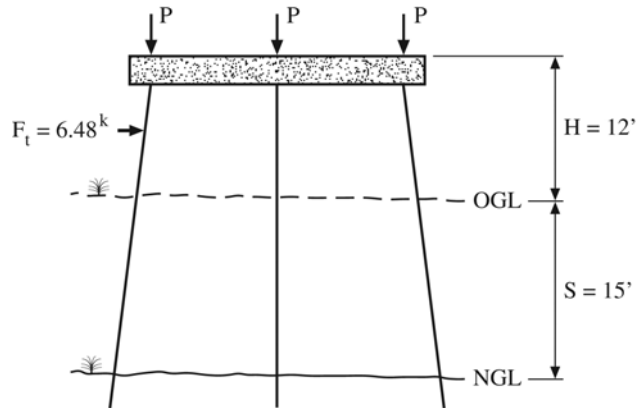
$$\sigma_{\text{crushing}} = 7.0 \text{ ksi} \quad \rightarrow \quad P_{\text{crushing}} = \sigma_{\text{crushing}} \cdot A_{\text{base}} = 7 \text{ ksi} \cdot 93.5 \cdot \text{in}^2 = 654.5 \text{ kips}$$

Therefore section is controlled by buckling, rather than crushing.

Finally, by applying the interaction equation:

$$\frac{P_{\text{axial}}}{P_{\text{cr}}} + \frac{M_{\text{Max}}}{M_{\text{rupture}}} = \frac{20 \cdot \text{kips}}{44.8 \cdot \text{kips}} + \frac{61.6 \cdot \text{kip} \cdot \text{ft}}{127.9 \cdot \text{kip} \cdot \text{ft}} = 0.45 + 0.48 = 0.93 > 0.75 \rightarrow \text{NG! for } P = 20 \text{ kips}$$

For the following unbraced bent geometry:  $H = 12$  ft,  $S = 15$  ft, 3-Pile Bent,  $F_t = 6.48$  kips



Only  $P = 20$  kips needs to be checked for the smaller raft for 14in diameter pile since others P-loads fail in buckling alone.

Recall,

$$A_{\text{eff}} = \frac{\pi \cdot (11.84\text{in})^2}{4} = 110.1 \text{ in}^2$$

$$P_{\text{cr}} = \frac{0.25 \cdot \pi^2 \cdot E \cdot I_{\text{eff}}}{L^2} = \frac{0.25 \cdot \pi^2 \cdot 1800\text{ksi} \cdot 964\text{in}^4}{(25.75\text{ft} \cdot 12)^2} = 44.8 \text{ kips}$$

Check at interaction equation at base (smallest section, therefore most critical):

$$d_{\text{base}} = 14\text{in} - (25.75\text{ft} \cdot 0.12 \frac{\text{in}}{\text{ft}}) = 10.91 \text{ in} \quad I_{\text{base}} = \frac{\pi \cdot (10.91\text{in})^4}{64} = 695.4 \text{ in}^4$$

$$A_{\text{base}} = \frac{\pi \cdot (10.91\text{in})^2}{4} = 93.5 \text{ in}^2 \quad S_{\text{base}} = \frac{\pi \cdot (10.91\text{in})^3}{32} = 127.9\text{in}^3$$

Recall,

$$\sigma_{\text{rupture}} = 12.0 \text{ ksi} \quad \rightarrow \quad M_{\text{rupture}} = \sigma_{\text{rupture}} \cdot S_{\text{base}} = 12\text{ksi} \cdot 127.9 \cdot \text{in}^3 = 127.9 \text{ kip-ft}$$

$$\sigma_{\text{crushing}} = 7.0 \text{ ksi} \quad \rightarrow \quad P_{\text{crushing}} = \sigma_{\text{crushing}} \cdot A_{\text{base}} = 7\text{ksi} \cdot 93.5 \cdot \text{in}^2 = 654.5 \text{ kips}$$

Therefore section is controlled by buckling, rather than crushing.

Finally, by applying the interaction equation:

$$\frac{P_{\text{axial}}}{P_{\text{cr}}} + \frac{M_{\text{Max}}}{M_{\text{rupture}}} = \frac{20 \cdot \text{kips}}{44.8 \cdot \text{kips}} + \frac{41.07 \cdot \text{kip} \cdot \text{ft}}{127.9 \cdot \text{kip} \cdot \text{ft}} = 0.45 + 0.32 = 0.77 > 0.75 \rightarrow \text{NG! for } P = 20 \text{ kips}$$

## **APPENDIX D**

### **Automated Screening Tool Visual Basic Code**

## Appendix D.1 Preliminary Evaluation and Related Modules

```
Public Class Intro
```

```
    Private Sub Button1_Click(ByVal sender As System.Object, ByVal e As System.EventArgs)
Handles Button1.Click
    'Show next form
    My.Forms.PreliminaryEval.Show()
    WindowState = FormWindowState.Minimized

    End Sub
```

```
    Private Sub HelpToolStripButton_Click(ByVal sender As System.Object, ByVal e As
System.EventArgs) Handles HelpToolStripButton.Click
    My.Forms.GeneralHelpFile.ShowDialog()
    End Sub
End Class
```

```
Public Class GeneralHelpFile
```

```
    Private Sub Button1_Click(ByVal sender As System.Object, ByVal e As System.EventArgs)
Handles Button1.Click
    Me.DialogResult = DialogResult.OK
    End Sub
End Class
```

```
Public Class PreliminaryEval
```

```
    Private Sub PreliminaryEval_Load(ByVal sender As System.Object, ByVal e As
System.EventArgs) Handles MyBase.Load

    'Following code lines are for placing options in dropdown boxes
    'Number of Piles drop-down box
    ComboBoxNoOfPiles.Items.Add("3")
    ComboBoxNoOfPiles.Items.Add("4")
    ComboBoxNoOfPiles.Items.Add("5")
    ComboBoxNoOfPiles.Items.Add("More than 5 piles")

    'PileDiameter drop-down box
    ComboBoxPileDiameter.Items.Add("12 in")
    ComboBoxPileDiameter.Items.Add("14 in")

    'Adds options to the X-Bracing combo box
    ComboBoxBracingScheme.Items.Add("Non-Braced")
    ComboBoxBracingScheme.Items.Add("X-Braced")

    End Sub
```



```

Private Sub Button2_Click(ByVal sender As System.Object, ByVal e As System.EventArgs)
Handles Button2.Click
    'Exit routine
End
End Sub

Private Sub RadioButton2_CheckedChanged(ByVal sender As System.Object, ByVal e As
System.EventArgs) Handles RadioButton2.CheckedChanged
    'Checks if ST is applicable
    If RadioButton2.Checked = True Then
        MsgBox("Bent is safe from scour! Please exit the Screening Tool.")
    End If
End Sub

Private Sub Button1_Click(ByVal sender As System.Object, ByVal e As System.EventArgs)
Handles Button1.Click
    'Recieves input from user for future calculations
    Lbg = Val(txtLbg.Text)
    Smax = Val(txtScr.Text)
    BentHeight = Val(txtBentHeight.Text)
    Span = Val(SpanText.Text)
    WaterDepth = Val(WaterDepthText.Text)

    'Fill variable associated with combo boxes
    'Diameter
    Select Case ComboBoxPileDiameter.SelectedIndex
        Case 0 '12in
            Dia = 12 'inches
        Case 1
            Dia = 14 'inches
    End Select

    'Number of Piles
    Select Case ComboBoxNoOfPiles.SelectedIndex
        Case 0
            NoPiles = 3
        Case 1
            NoPiles = 4
        Case 2
            NoPiles = 5
        Case 3
            NoPiles = 0
    End Select

    'Bracing Scheme
    Select Case ComboBoxBracingScheme.SelectedIndex
        Case 0
            Bracing = "Non-braced"
        Case 1
            Bracing = "X-braced"
    End Select
    If RadioButton4.Checked = True Then
        DebrisRaft = "Yes"
    Else
        DebrisRaft = "No"
    End If

    'Check applicability of ST

```

```

    If NoPiles = 0 Then
        MsgBox("Screening Tool cannot check adequacy of this bent. Please exit the
Screening Tool.")
    Else
        If RadioButton6.Checked = True Then 'Marine borer rot is an issue
            MsgBox("Corrective action should be taken to build pile section to
original or greater diameter.")
            'Calculate new length of pile embedment
            Las = Lbg - Smax

            'Check Kick-out Failure
            If Smax >= Lbg Then
                MsgBox("Bent will have kick-out failure! Take corrective action
immediately!")
            End If

            'Continuation message
            PictureBox1.Visible = True
            Label1.Visible = True
            PictureBox2.Visible = False

        Else
            'Calculate new length of pile embedment
            Las = Lbg - Smax

            'Check Kick-out Failure
            If Smax >= Lbg Then
                MsgBox("Bent will have kick-out failure! Take corrective action
immediately!")
            End If

            'Continuation message
            PictureBox1.Visible = True
            Label1.Visible = True
            PictureBox2.Visible = False

        End If
    End If
End Sub

'Displays Help File
Private Sub HelpToolStripButton_Click(ByVal sender As System.Object, ByVal e As
System.EventArgs) Handles HelpToolStripButton.Click
    My.Forms.PrelimHelpFile.ShowDialog()

End Sub

Private Sub Button3_Click(ByVal sender As System.Object, ByVal e As System.EventArgs)
Handles Button3.Click

    'Show next form
    My.Forms.PMaxEvalForm.Show()
    WindowState = FormWindowState.Minimized

End Sub

Private Sub RadioButton7_CheckedChanged(ByVal sender As System.Object, ByVal e As
System.EventArgs) Handles RadioButton7.CheckedChanged

```

```
        'Checks if ST is applicable
        If RadioButton7.Checked = True Then
            MsgBox("Screening Tool is meant for the evaluation of timber pile bents.
Please Exit.")
        End If
    End Sub

End Class
Public Class PrelimHelpFile

    'Closes Help File Dialog Box
    Private Sub Button1_Click(ByVal sender As System.Object, ByVal e As System.EventArgs)
Handles Button1.Click
        Me.DialogResult = DialogResult.OK
    End Sub

End Class
```

## Appendix D.2 Input Variables Module

### Module InputVariables

```
'Define Limit State Safety Check as True/False for easier output in report (False
being UNSAFE)
Public Plunging, KickOut, Buckling, Pushover, BeamColumn As String

'Define Public variables for use in other forms
Public Lbg, Las, Smax, BentHeight, Dia, Span, WaterDepth, PLoad As Single
Public NoPiles As Integer
Public DebrisRaft, Bracing As String

'Define Public variables for Pmax Eval
Public PileAppliedMax, BentAppliedMax As Single

'Define Public variables for Plunging Eval
Public vBentNo1, vHammerEnergy1, vDrivingResistance1, vLas1, vFrictionCapacity1,
vFrictionCritScour1, vFrictionSafety1, vEndBear1, vBearCritScour1, vBearingSafety1 As
String
Public vBentNo2, vHammerEnergy2, vDrivingResistance2, vLas2, vFrictionCapacity2,
vFrictionCritScour2, vFrictionSafety2, vEndBear2, vBearCritScour2, vBearingSafety2 As
String
Public vBentNo3, vHammerEnergy3, vDrivingResistance3, vLas3, vFrictionCapacity3,
vFrictionCritScour3, vFrictionSafety3, vEndBear3, vBearCritScour3, vBearingSafety3 As
String
Public vBentNo4, vHammerEnergy4, vDrivingResistance4, vLas4, vFrictionCapacity4,
vFrictionCritScour4, vFrictionSafety4, vEndBear4, vBearCritScour4, vBearingSafety4 As
String
Public vBentNo5, vHammerEnergy5, vDrivingResistance5, vLas5, vFrictionCapacity5,
vFrictionCritScour5, vFrictionSafety5, vEndBear5, vBearCritScour5, vBearingSafety5 As
String
Public PMaxPlunge, DrivingResistance, DrivingEnergy, EndBearingCapacity,
FrictionCapacity, HammerEnergy, Efficiency As Single
Public ScrEndBearing, ScrFriction As Single
Public HammerType, PileType As String
Public BentNo As Integer
Public BearingSafe, FrictionSafe As String

'Define Public variables for Buckling Eval
Public DiaEff, DiaEffBelowBrace, IEff, IEffBelowBrace, Lag, LagBelowBrace, ModulusE
As Single
Public C1, C2, C3 As Single
Public Pi As Double

'Define Public variables for Pushover Eval
Public RaftForce, PloadMax, PushoverScour, PushoverHeight As Single

'Define Public variables for BeamColumn Eval
Public CritScourBeamCol As String
```

```
'Define Public variables for Printing form  
Public Engineer, CheckDate, BIN, City, County, Notes As String  
Public IEffTextVal, LcrTextVal, ScourCritTextVal As Single  
Public FailureModeTextVal, PushoverCritScourTextVal As String
```

```
End Module
```

## Appendix D.3 Pile And Bent Applied Load Evaluation and Related Modules

```
Public Class PMaxEvalForm

    Private Sub EnterButton_Click(ByVal sender As System.Object, ByVal e As
System.EventArgs) Handles EnterButton.Click
        PileAppliedMax = Val(PApplKnownText.Text)
        BentAppliedMax = Val(BentApplKnownText.Text)

        PLoad = PileAppliedMax

        EnterArrow.Visible = False
        ContinueArrow.Visible = True
        Label11.Visible = True

    End Sub

    Private Sub ContinueButton_Click(ByVal sender As System.Object, ByVal e As
System.EventArgs) Handles ContinueButton.Click
        'Show next form
        My.Forms.PlungingEval.Show()
        WindowState = FormWindowState.Minimized
    End Sub

    Private Sub ExitButton_Click(ByVal sender As System.Object, ByVal e As
System.EventArgs) Handles ExitButton.Click
        'Exit routine
    End
    End Sub

    Private Sub HelpToolStripButton_Click(ByVal sender As System.Object, ByVal e As
System.EventArgs) Handles HelpToolStripButton.Click
        My.Forms.PileAppliedLoadHelp.ShowDialog()
    End Sub
End Class

Public Class PileAppliedLoadHelp

    Private Sub Button1_Click(ByVal sender As System.Object, ByVal e As System.EventArgs)
Handles Button1.Click
        Me.DialogResult = DialogResult.OK
    End Sub
End Class
```

## Appendix D.4 Plunging and Kick-out Evaluation and Related Modules

```
Public Class PlungingEval

    Public Las1, Las2, Las3, Las4, Las5, Las6 As Single

    Private Sub ExitButton_Click(ByVal sender As System.Object, ByVal e As
System.EventArgs) Handles ExitButton.Click
        'Exit routine
        End
    End Sub

    Private Sub PlungingEval_Load(ByVal sender As System.Object, ByVal e As
System.EventArgs) Handles MyBase.Load
        'Following code lines are for placing options in dropdown boxes
        'Hammer Type drop-down box
        HammerTypeCombo.Items.Add("Single Acting Air/Steam (Assumed 67% Efficient)")
        HammerTypeCombo.Items.Add("Double Acting Air/Steam (Assumed 50% Efficient)")
        HammerTypeCombo.Items.Add("Diesel (Assumed 80% Efficient)")
        HammerTypeCombo.Items.Add("Drop Hammer (Assumed 50% Efficient)")

    End Sub

    Private Sub EnterButton_Click(ByVal sender As System.Object, ByVal e As
System.EventArgs) Handles EnterButton.Click
        'Recieve input data and put to variables
        HammerType = HammerTypeCombo.SelectedItem
        'Convert Pile Load to tons and show in form for comparison purposes
        PMaxPlunge = PileAppliedMax / 2 'tons
        PMaxApplied.Text = PMaxPlunge.ToString("###0.00")

        'Run plunging evaluation for each column of input data
        If Val(BentNo1.Text) <> 0 Then
            'Gather input from user
            Lbg = Val(Lbg1.Text) 'ft
            Smax = Val(Scour1.Text) 'ft
            DrivingResistance = Val(DrivingResist1.Text) 'bpi
            HammerEnergy = Val(HammerEnergy1.Text) 'ft-lbs
            If HammerType = "Single Acting Air/Steam (Assumed 67% Efficient)" Then
                HammerEnergy = 0.67 * HammerEnergy
                Efficiency = "67"
            ElseIf HammerType = "Double Acting Air/Steam (Assumed 50% Efficient)" Then
                HammerEnergy = 0.5 * HammerEnergy
                Efficiency = "50"
            ElseIf HammerType = "Diesel (Assumed 80% Efficient)" Then
                HammerEnergy = 0.8 * HammerEnergy
                Efficiency = "80"
            Else
                HammerEnergy = 0.5 * HammerEnergy
                Efficiency = "50"
            End If
        End If
    End Sub
End Class
```

```

End If

'Send input to Plunging Functions module
ScrEndBearing = CritScourPlunging_EndBearing(HammerEnergy, DrivingResistance,
PMaxPlunge, Lbg)
EndBearingCapacity = EndBearingCapacityEval(HammerEnergy, DrivingResistance,
Smax, Lbg)
ScrFriction = CritScourPlunging_Friction(HammerEnergy, DrivingResistance,
PMaxPlunge, Lbg)
FrictionCapacity = FrictionCapacityEval(HammerEnergy, DrivingResistance,
Smax, Lbg)

'Output results back to form
EndBear1.Text = EndBearingCapacity.ToString("###0.00")
BearCritScour1.Text = ScrEndBearing.ToString("###0.00")
FrictionCapacity1.Text = FrictionCapacity.ToString("###0.00")
FrictionCritScour1.Text = ScrFriction.ToString("###0.00")

'Format for safe/unsafe checks
'End bearing failure checks
If ScrEndBearing < 0 Then
    MsgBox("Projected critical scour value is negative, therefore maximum
applied load is greater than pile capacity.")
    BearingSafety1.ForeColor = Color.Red
    BearingSafety1.Text = "UNSAFE"
End If

If ScrEndBearing >= Smax Then
    BearingSafety1.ForeColor = Color.Blue
    BearingSafety1.Text = "SAFE"
Else
    BearingSafety1.ForeColor = Color.Red
    BearingSafety1.Text = "UNSAFE"
End If

'Friction failure checks
If ScrFriction < 0 Then
    MsgBox("Projected critical scour value is negative, therefore maximum
applied load is greater than pile capacity.")
    FrictionSafety1.ForeColor = Color.Red
    FrictionSafety1.Text = "UNSAFE"
End If

If ScrFriction >= Smax Then
    FrictionSafety1.ForeColor = Color.Blue
    FrictionSafety1.Text = "SAFE"
Else
    FrictionSafety1.ForeColor = Color.Red
    FrictionSafety1.Text = "UNSAFE"
End If

'Kickout failure check (input recieved, checked later)
Las1 = Val(Lbg1.Text) - Val(Scour1.Text) 'ft
If Las1 < 2.5 Then
    MsgBox("Pile in Column 1 unsafe for kick-out. Take preventative measures
such as riprap.")
ElseIf 2.5 <= Las1 And Las1 < 5 Then

```



```

        MsgBox("Pile in Column 1 in danger of being unsafe for kick-out after
future scour events. Take preventative measures such as riprap.")
    Else
    End If

End If

'Repeat for Bent 2 Column
If Val(BentNo2.Text) <> 0 Then
    'Gather input from user
    Lbg = Val(Lbg2.Text) 'ft
    Smax = Val(Scour2.Text) 'ft
    DrivingResistance = Val(DrivingResist2.Text) 'bpi
    HammerEnergy = Val(HammerEnergy2.Text) 'ft-lbs
    If HammerType = "Single Acting Air/Steam (Assumed 67% Efficient)" Then
        HammerEnergy = 0.67 * HammerEnergy
    ElseIf HammerType = "Double Acting Air/Steam (Assumed 50% Efficient)" Then
        HammerEnergy = 0.5 * HammerEnergy
    ElseIf HammerType = "Diesel (Assumed 80% Efficient)" Then
        HammerEnergy = 0.8 * HammerEnergy
    Else
        HammerEnergy = 0.5 * HammerEnergy
    End If

    'Send input to Plunging Functions module
    ScrEndBearing = CritScourPlunging_EndBearing(HammerEnergy, DrivingResistance,
PMaxPlunge, Lbg)
    EndBearingCapacity = EndBearingCapacityEval(HammerEnergy, DrivingResistance,
Smax, Lbg)
    ScrFriction = CritScourPlunging_Friction(HammerEnergy, DrivingResistance,
PMaxPlunge, Lbg)
    FrictionCapacity = FrictionCapacityEval(HammerEnergy, DrivingResistance,
Smax, Lbg)

    'Output results back to form
    EndBear2.Text = EndBearingCapacity.ToString("###0.00")
    BearCritScour2.Text = ScrEndBearing.ToString("###0.00")
    FrictionCapacity2.Text = FrictionCapacity.ToString("###0.00")
    FrictionCritScour2.Text = ScrFriction.ToString("###0.00")

    'Format for safe/unsafe checks
    'End bearing failure checks
    If ScrEndBearing < 0 Then
        MsgBox("Projected critical scour value is negative, therefore maximum
applied load is greater than pile capacity.")
        BearingSafety2.ForeColor = Color.Red
        BearingSafety2.Text = "UNSAFE"
    End If

    If ScrEndBearing >= Smax Then
        BearingSafety2.ForeColor = Color.Blue
        BearingSafety2.Text = "SAFE"
    Else
        BearingSafety2.ForeColor = Color.Red
        BearingSafety2.Text = "UNSAFE"
    End If

    'Friction failure checks

```

```

If ScrFriction < 0 Then
    MsgBox("Projected critical scour value is negative, therefore maximum
applied load is greater than pile capacity.")
    FrictionSafety2.ForeColor = Color.Red
    FrictionSafety2.Text = "UNSAFE"
End If

If ScrFriction >= Smax Then
    FrictionSafety2.ForeColor = Color.Blue
    FrictionSafety2.Text = "SAFE"
Else
    FrictionSafety2.ForeColor = Color.Red
    FrictionSafety2.Text = "UNSAFE"
End If

'Kickout failure check (input recieved, checked later)
Las2 = Val(Lbg2.Text) - Val(Scour2.Text)
If Las2 < 2.5 Then
    MsgBox("Pile in Column 2 unsafe for kick-out. Take preventative measures
such as riprap.")
    ElseIf 2.5 <= Las2 And Las2 < 5 Then
        MsgBox("Pile in Column 2 in danger of being unsafe for kick-out after
future scour events. Take preventative measures such as riprap.")
    Else
    End If

End If

'Repeat for Bent 3 column
If Val(BentNo3.Text) <> 0 Then
    'Gather input from user
    Lbg = Val(Lbg3.Text) 'ft
    Smax = Val(Scour3.Text) 'ft
    DrivingResistance = Val(DrivingResist3.Text) 'bpi
    HammerEnergy = Val(HammerEnergy3.Text) 'ft-lbs
    If HammerType = "Single Acting Air/Steam (Assumed 67% Efficient)" Then
        HammerEnergy = 0.67 * HammerEnergy
    ElseIf HammerType = "Double Acting Air/Steam (Assumed 50% Efficient)" Then
        HammerEnergy = 0.5 * HammerEnergy
    ElseIf HammerType = "Diesel (Assumed 80% Efficient)" Then
        HammerEnergy = 0.8 * HammerEnergy
    Else
        HammerEnergy = 0.5 * HammerEnergy
    End If

    'Send input to Plunging Functions module
    ScrEndBearing = CritScourPlunging_EndBearing(HammerEnergy, DrivingResistance,
PMaxPlunge, Lbg)
    EndBearingCapacity = EndBearingCapacityEval(HammerEnergy, DrivingResistance,
Smax, Lbg)
    ScrFriction = CritScourPlunging_Friction(HammerEnergy, DrivingResistance,
PMaxPlunge, Lbg)
    FrictionCapacity = FrictionCapacityEval(HammerEnergy, DrivingResistance,
Smax, Lbg)

    'Output results back to form
    EndBear3.Text = EndBearingCapacity.ToString("###0.00")
    BearCritScour3.Text = ScrEndBearing.ToString("###0.00")

```

```

FrictionCapacity3.Text = FrictionCapacity.ToString("###0.00")
FrictionCritScour3.Text = ScrFriction.ToString("###0.00")

'Format for safe/unsafe checks
'End bearing failure checks
If ScrEndBearing < 0 Then
    MsgBox("Projected critical scour value is negative, therefore maximum
applied load is greater than pile capacity.")
    BearingSafety3.ForeColor = Color.Red
    BearingSafety3.Text = "UNSAFE"
End If

If ScrEndBearing >= Smax Then
    BearingSafety3.ForeColor = Color.Blue
    BearingSafety3.Text = "SAFE"
Else
    BearingSafety3.ForeColor = Color.Red
    BearingSafety3.Text = "UNSAFE"
End If

'Friction failure checks
If ScrFriction < 0 Then
    MsgBox("Projected critical scour value is negative, therefore maximum
applied load is greater than pile capacity.")
    FrictionSafety3.ForeColor = Color.Red
    FrictionSafety3.Text = "UNSAFE"
End If

If ScrFriction >= Smax Then
    FrictionSafety3.ForeColor = Color.Blue
    FrictionSafety3.Text = "SAFE"
Else
    FrictionSafety3.ForeColor = Color.Red
    FrictionSafety3.Text = "UNSAFE"
End If

'Kickout failure check (input recieved, checked later)
Las3 = Val(Lbg3.Text) - Val(Scour3.Text)
If Las3 < 2.5 Then
    MsgBox("Pile in Column 3 unsafe for kick-out. Take preventative measures
such as riprap.")
ElseIf 2.5 <= Las3 And Las3 < 5 Then
    MsgBox("Pile in Column 3 in danger of being unsafe for kick-out after
future scour events. Take preventative measures such as riprap.")
Else
End If
End If

'Repeat for Bent Column 4
If Val(BentNo4.Text) <> 0 Then
    'Gather input from user
    Lbg = Val(Lbg4.Text) 'ft
    Smax = Val(Scour4.Text) 'ft
    DrivingResistance = Val(DrivingResist4.Text) 'bpi
    HammerEnergy = Val(HammerEnergy4.Text) 'ft-lbs
    If HammerType = "Single Acting Air/Steam (Assumed 67% Efficient)" Then
        HammerEnergy = 0.67 * HammerEnergy
    End If
End If

```

```

ElseIf HammerType = "Double Acting Air/Steam (Assumed 50% Efficient)" Then
    HammerEnergy = 0.5 * HammerEnergy
ElseIf HammerType = "Diesel (Assumed 80% Efficient)" Then
    HammerEnergy = 0.8 * HammerEnergy
Else
    HammerEnergy = 0.5 * HammerEnergy
End If

'Send input to Plunging Functions module
ScrEndBearing = CritScourPlunging_EndBearing(HammerEnergy, DrivingResistance,
PMaxPlunge, Lbg)
EndBearingCapacity = EndBearingCapacityEval(HammerEnergy, DrivingResistance,
Smax, Lbg)
ScrFriction = CritScourPlunging_Friction(HammerEnergy, DrivingResistance,
PMaxPlunge, Lbg)
FrictionCapacity = FrictionCapacityEval(HammerEnergy, DrivingResistance,
Smax, Lbg)

'Output results back to form
EndBear4.Text = EndBearingCapacity.ToString("###0.00")
BearCritScour4.Text = ScrEndBearing.ToString("###0.00")
FrictionCapacity4.Text = FrictionCapacity.ToString("###0.00")
FrictionCritScour4.Text = ScrFriction.ToString("###0.00")

'Format for safe/unsafe checks
'End bearing failure checks
If ScrEndBearing < 0 Then
    MsgBox("Projected critical scour value is negative, therefore maximum
applied load is greater than pile capacity.")
    BearingSafety4.ForeColor = Color.Red
    BearingSafety4.Text = "UNSAFE"
End If

If ScrEndBearing >= Smax Then
    BearingSafety4.ForeColor = Color.Blue
    BearingSafety4.Text = "SAFE"
Else
    BearingSafety4.ForeColor = Color.Red
    BearingSafety4.Text = "UNSAFE"
End If

'Friction failure checks
If ScrFriction < 0 Then
    MsgBox("Projected critical scour value is negative, therefore maximum
applied load is greater than pile capacity.")
    FrictionSafety4.ForeColor = Color.Red
    FrictionSafety4.Text = "UNSAFE"
End If

If ScrFriction >= Smax Then
    FrictionSafety4.ForeColor = Color.Blue
    FrictionSafety4.Text = "SAFE"
Else
    FrictionSafety4.ForeColor = Color.Red
    FrictionSafety4.Text = "UNSAFE"
End If

'Kickout failure check (input recieved, checked later)

```

```

Las4 = Val(Lbg4.Text) - Val(Scour4.Text)
If Las4 < 2.5 Then
    MsgBox("Pile in Column 4 unsafe for kick-out. Take preventative measures
such as riprap.")
ElseIf 2.5 <= Las4 And Las4 < 5 Then
    MsgBox("Pile in Column 4 in danger of being unsafe for kick-out after
future scour events. Take preventative measures such as riprap.")
Else
End If

End If

'Repeat for bent column 5
If Val(BentNo5.Text) <> 0 Then
    'Gather input from user
    Lbg = Val(Lbg5.Text) 'ft
    Smax = Val(Scour5.Text) 'ft
    DrivingResistance = Val(DrivingResist5.Text) 'bpi
    HammerEnergy = Val(HammerEnergy5.Text) 'ft-lbs
    If HammerType = "Single Acting Air/Steam (Assumed 67% Efficient)" Then
        HammerEnergy = 0.67 * HammerEnergy
    ElseIf HammerType = "Double Acting Air/Steam (Assumed 50% Efficient)" Then
        HammerEnergy = 0.5 * HammerEnergy
    ElseIf HammerType = "Diesel (Assumed 80% Efficient)" Then
        HammerEnergy = 0.8 * HammerEnergy
    Else
        HammerEnergy = 0.5 * HammerEnergy
    End If

    'Send input to Plunging Functions module
    ScrEndBearing = CritScourPlunging_EndBearing(HammerEnergy, DrivingResistance,
PMaxPlunge, Lbg)
    EndBearingCapacity = EndBearingCapacityEval(HammerEnergy, DrivingResistance,
Smax, Lbg)
    ScrFriction = CritScourPlunging_Friction(HammerEnergy, DrivingResistance,
PMaxPlunge, Lbg)
    FrictionCapacity = FrictionCapacityEval(HammerEnergy, DrivingResistance,
Smax, Lbg)

    'Output results back to form
    EndBear5.Text = EndBearingCapacity.ToString("###0.00")
    BearCritScour5.Text = ScrEndBearing.ToString("###0.00")
    FrictionCapacity5.Text = FrictionCapacity.ToString("###0.00")
    FrictionCritScour5.Text = ScrFriction.ToString("###0.00")

    'Format for safe/unsafe checks
    'End bearing failure checks
    If ScrEndBearing < 0 Then
        MsgBox("Projected critical scour value is negative, therefore maximum
applied load is greater than pile capacity.")
        BearingSafety5.ForeColor = Color.Red
        BearingSafety5.Text = "UNSAFE"
    End If

    If ScrEndBearing >= Smax Then
        BearingSafety5.ForeColor = Color.Blue
        BearingSafety5.Text = "SAFE"
    Else

```

```

        BearingSafety5.ForeColor = Color.Red
        BearingSafety5.Text = "UNSAFE"
    End If

    'Friction failure checks
    If ScrFriction < 0 Then
        MsgBox("Projected critical scour value is negative, therefore maximum
applied load is greater than pile capacity.")
        FrictionSafety5.ForeColor = Color.Red
        FrictionSafety5.Text = "UNSAFE"
    End If

    If ScrFriction >= Smax Then
        FrictionSafety5.ForeColor = Color.Blue
        FrictionSafety5.Text = "SAFE"
    Else
        FrictionSafety5.ForeColor = Color.Red
        FrictionSafety5.Text = "UNSAFE"
    End If

    'Kickout failure check (input recieved, checked later)
    Las5 = Val(Lbg5.Text) - Val(Scour5.Text)
    If Las5 < 2.5 Then
        MsgBox("Pile in Column 5 unsafe for kick-out. Take preventative measures
such as riprap.")
    ElseIf 2.5 <= Las5 And Las5 < 5 Then
        MsgBox("Pile in Column 5 in danger of being unsafe for kick-out after
future scour events. Take preventative measures such as riprap.")
    Else
    End If
End If

    'Kickout failure check to send to conclusion module
    If (Val(BentNo1.Text) <> 0 And Las1 < 2.5) Or (Val(BentNo2.Text) <> 0 And Las2 <
2.5) Or (Val(BentNo3.Text) <> 0 And Las3 < 2.5) Or (Val(BentNo4.Text) <> 0 And Las4 <
2.5) Or (Val(BentNo5.Text) <> 0 And Las5 < 2.5) Then
        KickOut = "Unsafe!"
    ElseIf (Val(BentNo1.Text) <> 0 And 2.5 <= Las1 And Las1 < 5) Or
(Val(BentNo2.Text) <> 0 And 2.5 <= Las2 And Las2 < 5) Or (Val(BentNo3.Text) <> 0 And 2.5
<= Las3 And Las3 < 5) Or (Val(BentNo4.Text) <> 0 And 2.5 <= Las4 And Las4 < 5) Or
(Val(BentNo5.Text) <> 0 And 2.5 <= Las5 And Las5 < 5) Then
        KickOut = "Possibly unsafe for future scour events!"
    Else : KickOut = "Safe!"
        MsgBox("Piles are safe from kick-out failure.")
    End If

    'Send evaluation to Master Plunging Failure variable
    If BearingSafety1.Text = "UNSAFE" Or BearingSafety2.Text = "UNSAFE" Or
BearingSafety3.Text = "UNSAFE" Or BearingSafety4.Text = "UNSAFE" Or BearingSafety5.Text =
"UNSAFE" Then
        BearingSafe = "False"
    End If

    If FrictionSafety1.Text = "UNSAFE" Or FrictionSafety2.Text = "UNSAFE" Or
FrictionSafety3.Text = "UNSAFE" Or FrictionSafety4.Text = "UNSAFE" Or
FrictionSafety5.Text = "UNSAFE" Then

```

```

        FrictionSafe = "False"
    End If

    If BearingSafe = "False" Then
        If FrictionSafe = "False" Then
            Plunging = "Unsafe in both Bearing and Friction!"
        Else : Plunging = "Unsafe in Bearing!"
        End If
    Else
        If FrictionSafe = "False" Then
            Plunging = "Unsafe in Friction!"
        Else
            Plunging = "Safe!"
        End If
    End If

    PictureBox2.Visible = True
    EnterArrow.Visible = False
    Label2.Visible = True
End Sub

```

```

Private Sub ClrButton_Click(ByVal sender As System.Object, ByVal e As
System.EventArgs) Handles ClrButton.Click
    'Clear all inputs
    BentNo1.Text = ""
    DrivingResist1.Text = ""
    HammerEnergy1.Text = ""
    Scour1.Text = ""
    Lbg1.Text = ""
    EndBear1.Text = ""
    BearCritScour1.Text = ""
    BearingSafety1.Text = ""
    FrictionCapacity1.Text = ""
    FrictionCritScour1.Text = ""
    FrictionSafety1.Text = ""

    BentNo2.Text = ""
    DrivingResist2.Text = ""
    HammerEnergy2.Text = ""
    Scour2.Text = ""
    Lbg2.Text = ""
    EndBear2.Text = ""
    BearCritScour2.Text = ""
    BearingSafety2.Text = ""
    FrictionCapacity2.Text = ""
    FrictionCritScour2.Text = ""
    FrictionSafety2.Text = ""

    BentNo3.Text = ""
    DrivingResist3.Text = ""
    HammerEnergy3.Text = ""
    Scour3.Text = ""
    Lbg3.Text = ""
    EndBear3.Text = ""
    BearCritScour3.Text = ""
    BearingSafety3.Text = ""

```

```
FrictionCapacity3.Text = ""
FrictionCritScour3.Text = ""
FrictionSafety3.Text = ""
```

```
BentNo4.Text = ""
DrivingResist4.Text = ""
HammerEnergy4.Text = ""
Scour4.Text = ""
Lbg4.Text = ""
EndBear4.Text = ""
BearCritScour4.Text = ""
BearingSafety4.Text = ""
FrictionCapacity4.Text = ""
FrictionCritScour4.Text = ""
FrictionSafety4.Text = ""
```

```
BentNo5.Text = ""
DrivingResist5.Text = ""
HammerEnergy5.Text = ""
Scour5.Text = ""
Lbg5.Text = ""
EndBear5.Text = ""
BearCritScour5.Text = ""
BearingSafety5.Text = ""
FrictionCapacity5.Text = ""
FrictionCritScour5.Text = ""
FrictionSafety5.Text = ""
```

```
EnterArrow.Visible = True
Label12.Visible = False
PictureBox2.Visible = False
```

```
End Sub
```

```
Private Sub Cont_Click(ByVal sender As System.Object, ByVal e As System.EventArgs)
Handles Cont.Click
```

```
vBentNo1 = BentNo1.Text
vBentNo2 = BentNo2.Text
vBentNo3 = BentNo3.Text
vBentNo4 = BentNo4.Text
vBentNo5 = BentNo5.Text
```

```
vHammerEnergy1 = HammerEnergy1.Text
vHammerEnergy2 = HammerEnergy2.Text
vHammerEnergy3 = HammerEnergy3.Text
vHammerEnergy4 = HammerEnergy4.Text
vHammerEnergy5 = HammerEnergy5.Text
```

```
vDrivingResistance1 = DrivingResist1.Text
vDrivingResistance2 = DrivingResist2.Text
vDrivingResistance3 = DrivingResist3.Text
vDrivingResistance4 = DrivingResist4.Text
vDrivingResistance5 = DrivingResist5.Text
```

```
If Las1 <> 0 Then
```



```

        vLas1 = Las1
    End If
    If Las2 <> 0 Then
        vLas2 = Las2
    End If
    If Las3 <> 0 Then
        vLas3 = Las3
    End If
    If Las4 <> 0 Then
        vLas4 = Las4
    End If
    If Las5 <> 0 Then
        vLas5 = Las5
    End If

    vFrictionCapacity1 = FrictionCapacity1.Text
    vFrictionCapacity2 = FrictionCapacity2.Text
    vFrictionCapacity3 = FrictionCapacity3.Text
    vFrictionCapacity4 = FrictionCapacity4.Text
    vFrictionCapacity5 = FrictionCapacity5.Text

    vFrictionCritScour1 = FrictionCritScour1.Text
    vFrictionCritScour2 = FrictionCritScour2.Text
    vFrictionCritScour3 = FrictionCritScour3.Text
    vFrictionCritScour4 = FrictionCritScour4.Text
    vFrictionCritScour5 = FrictionCritScour5.Text

    vFrictionSafety1 = FrictionSafety1.Text
    vFrictionSafety2 = FrictionSafety2.Text
    vFrictionSafety3 = FrictionSafety3.Text
    vFrictionSafety4 = FrictionSafety4.Text
    vFrictionSafety5 = FrictionSafety5.Text

    vEndBear1 = EndBear1.Text
    vEndBear2 = EndBear2.Text
    vEndBear3 = EndBear3.Text
    vEndBear4 = EndBear4.Text
    vEndBear5 = EndBear5.Text

    vBearCritScour1 = BearCritScour1.Text
    vBearCritScour2 = BearCritScour2.Text
    vBearCritScour3 = BearCritScour3.Text
    vBearCritScour4 = BearCritScour4.Text
    vBearCritScour5 = BearCritScour5.Text

    vBearingSafety1 = BearingSafety1.Text
    vBearingSafety2 = BearingSafety2.Text
    vBearingSafety3 = BearingSafety3.Text
    vBearingSafety4 = BearingSafety4.Text
    vBearingSafety5 = BearingSafety5.Text
    'Show next form
    My.Forms.BucklingEval.Show()
    WindowState = FormWindowState.Minimized

```

End Sub

```

    Private Sub Button2_Click(ByVal sender As System.Object, ByVal e As System.EventArgs)
Handles Button2.Click
    'Exit routine
    End
End Sub

    Private Sub HelpToolStripButton_Click(ByVal sender As System.Object, ByVal e As
System.EventArgs) Handles HelpToolStripButton.Click
    My.Forms.PlungingHelp.ShowDialog()
    End Sub
End Class

Public Class PlungingHelp

    Private Sub Button1_Click(ByVal sender As System.Object, ByVal e As System.EventArgs)
Handles Button1.Click
    Me.DialogResult = DialogResult.OK
    End Sub

End Class

```

## Appendix D.5 Buckling Evaluation and Related Modules

```
Public Class BucklingEval

    Public LCritNonSidesway, LCritSideswayBraced, LCritSideswayUnbraced As Single
    Public SCritNonSidesway, SCritSideswayBraced, SCritSideswayUnbraced As Single

    Private Sub ContinueButton_Click(ByVal sender As System.Object, ByVal e As
System.EventArgs) Handles ContinueButton.Click
        'Show next form
        My.Forms.PushoverEvaluation.Show()
        WindowState = FormWindowState.Minimized
    End Sub

    Private Sub ExitButton_Click(ByVal sender As System.Object, ByVal e As
System.EventArgs) Handles ExitButton.Click
        'Exit routine
        End
    End Sub

    Private Sub BucklingEval_Load(ByVal sender As System.Object, ByVal e As
System.EventArgs) Handles MyBase.Load

        'Show previous inputs in form
        XBracedText.Text = Bracing
        DiameterText.Text = Dia.ToString("###0")
        HeightText.Text = BentHeight.ToString("###0.0")
        ScourText.Text = Smax.ToString("###0.0")
        LasText.Text = Las.ToString("###0.0")
        PmaxAppliedText.Text = PileAppliedMax.ToString("###0.0")

        'Determine Effective Diameter of Pile for longitudinal and unbraced assuming
taper of 0.12in/ft
        Lag = BentHeight + Smax - 1.25 'ft
        DiaEff = Dia - (((2 / 3) * Lag) * 0.12) 'in

        'Determine Effective Diameter for Transverse below x-bracing calcs
        LagBelowBrace = Smax + 1.25
        DiaEffBelowBrace = Dia - (((2 / 3) * LagBelowBrace) + (BentHeight - 2.5)) *
0.12) 'in

        'Determine Effective Moments of Inertia
        Pi = 3.14159265
        IEff = (Pi * (DiaEff ^ 4)) / 64
        IEffBelowBrace = (Pi * (DiaEffBelowBrace ^ 4)) / 64
        ModulusE = 1800 'ksi

        'Determine C1 based off embedment after scour
        If Las >= 8 Then
            C1 = 2 'fixed
        End If
    End Sub
End Class
```

```

ElseIf Las >= 4 And Las < 8 Then
    C1 = 1.5 'partially fixed
Else
    C1 = 1 'pinned
End If

C2 = 0.5
C3 = 1 / 6

'X-Braced Buckling Evaluation
If Bracing = "X-braced" Then
    If WaterDepth = 0 Then 'bents out of water
        LCritNonSidesway = LCrit_NonSidesway(PileAppliedMax, IEff, C1)
        SCritNonSidesway = SCrit_NonSidesway(LCritNonSidesway, BentHeight)

        LCritSideswayBraced = LCrit_SideswayBraced(PileAppliedMax,
IEffBelowBrace, C2)
        SCritSideswayBraced = SCrit_SideswayBraced(LCritSideswayBraced,
BentHeight)

        If SCritNonSidesway < SCritSideswayBraced Then 'Non-Sidesway is
controlling mode
            FailureModeText.Text = "Nonsidesway buckling in the longitudinal
direction"

            LcrText.Text = LCritNonSidesway.ToString("###0.0")
            ScourCritText.Text = SCritNonSidesway.ToString("###0.0")
            IEffText.Text = IEff.ToString("###0.00")

            'Compare to max predicted scour
            If Smax > SCritNonSidesway Then
                BucklingSafetyText.ForeColor = Color.Red
                BucklingSafetyText.Text = "Unsafe!"
                Buckling = "Unsafe!"
            Else
                BucklingSafetyText.ForeColor = Color.Blue
                BucklingSafetyText.Text = "Safe!"
                Buckling = "Safe!"
            End If

        Else
            FailureModeText.Text = "Transverse sidesway buckling below the X-
bracing"

            'need to convert Lcrit to be from pile cap i.e. add in H - 2.5'
            LCritSideswayBraced = LCritSideswayBraced + BentHeight - 2.5 '
            LcrText.Text = LCritSideswayBraced.ToString("###0.0")
            ScourCritText.Text = SCritSideswayBraced.ToString("###0.0")
            IEffText.Text = IEffBelowBrace.ToString("###0.00")

            'Compare to max predicted scour
            If Smax > SCritSideswayBraced Then
                BucklingSafetyText.ForeColor = Color.Red
                BucklingSafetyText.Text = "Unsafe!"
                Buckling = "Unsafe!"
            Else
                BucklingSafetyText.ForeColor = Color.Blue
                BucklingSafetyText.Text = "Safe!"
                Buckling = "Safe!"
            End If
        End If
    End If
End If

```

```

        End If
    Else 'bents over water (repeated calcs, but transverse direction uses diff
function
        LCritNonSidesway = LCrit_NonSidesway(PileAppliedMax, IEff, C1)
        SCritNonSidesway = SCrit_NonSidesway(LCritNonSidesway, BentHeight)

        LCritSideswayBraced = LCrit_SideswayBraced(PileAppliedMax,
IEffBelowBrace, C2)
        SCritSideswayBraced = SCrit_SideswayBracedOverWater(LCritSideswayBraced,
BentHeight)

    If SCritNonSidesway < SCritSideswayBraced Then 'Non-Sidesway is
controlling mode
        FailureModeText.Text = "Nonsidesway buckling in the longitudinal
direction"

        LcrText.Text = LCritNonSidesway.ToString("###0.0")
        ScourCritText.Text = SCritNonSidesway.ToString("###0.0")
        IEffText.Text = IEff.ToString("###0.00")

        'Compare to max predicted scour
    If Smax > SCritNonSidesway Then
        BucklingSafetyText.ForeColor = Color.Red
        BucklingSafetyText.Text = "Unsafe!"
        Buckling = "Unsafe!"
    Else
        BucklingSafetyText.ForeColor = Color.Blue
        BucklingSafetyText.Text = "Safe!"
        Buckling = "Safe!"
    End If

    Else
bracing"
        FailureModeText.Text = "Transverse sidesway buckling below the X-

        'need to convert Lcrit to be from pile cap i.e. add in H - 2.5'
        LCritSideswayBraced = LCritSideswayBraced + BentHeight - 2.5 '
        LcrText.Text = LCritSideswayBraced.ToString("###0.0")
        ScourCritText.Text = SCritSideswayBraced.ToString("###0.0")
        IEffText.Text = IEffBelowBrace.ToString("###0.00")

        'Compare to max predicted scour
    If Smax > SCritSideswayBraced Then
        BucklingSafetyText.ForeColor = Color.Red
        BucklingSafetyText.Text = "Unsafe!"
        Buckling = "Unsafe!"
    Else
        BucklingSafetyText.ForeColor = Color.Blue
        BucklingSafetyText.Text = "Safe!"
        Buckling = "Safe!"
    End If
    End If
    'Unbraced Buckling Evaluation
Else
        LCritSideswayUnbraced = LCrit_SideswayUnBraced(PileAppliedMax, IEff, C3)
        SCritSideswayUnbraced = SCrit_SideswayUnBraced(LCritSideswayUnbraced,
BentHeight)

        FailureModeText.Text = "Transverse sidesway buckling from pile cap to NGL"

```

```

LcrText.Text = LCritSideswayUnbraced.ToString("###0.0")
ScourCritText.Text = SCritSideswayUnbraced.ToString("###0.0")
IEffText.Text = IEff.ToString("###0.00")
'Compare to max predicted scour
If Smax > SCritSideswayUnbraced Then
    BucklingSafetyText.ForeColor = Color.Red
    BucklingSafetyText.Text = "Unsafe!"
    Buckling = "Unsafe!"
Else
    BucklingSafetyText.ForeColor = Color.Blue
    BucklingSafetyText.Text = "Safe!"
    Buckling = "Safe!"
End If

End If

'put text output into new variables for output report
IEffTextVal = Val(IEffText.Text)
FailureModeTextVal = FailureModeText.Text
LcrTextVal = Val(LcrText.Text)
ScourCritTextVal = Val(ScourCritText.Text)

End Sub

End Class

Module BucklingFunctions

    Public E As Single

    'Buckling Functions include FS 1.33
    'Assumed brace located 1.25' above OGL for all except bent over water calc

    'Buckling NonSidesway
    Function LCrit_NonSidesway(ByVal PApplied As Single, ByVal EffInertia As Single,
ByVal C As Single)
        LCrit_NonSidesway = (((C * (Pi ^ 2) * ModulusE * EffInertia) / (1.33 * PApplied))
^ (0.5)) / 12 'ft
    End Function

    Function SCrit_NonSidesway(ByVal LCrit As Single, ByVal Ht As Single)
        SCrit_NonSidesway = LCrit + 1.25 - Ht 'ft
    End Function

    'Buckling Sidesway below X-Brace
    Function LCrit_SideswayBraced(ByVal PApplied As Single, ByVal EffInertia As Single,
ByVal C As Single)
        LCrit_SideswayBraced = (((C * (Pi ^ 2) * ModulusE * EffInertia) / (1.33 *
PApplied)) ^ (0.5)) / 12 'ft
    End Function

    Function SCrit_SideswayBraced(ByVal LCrit As Single, ByVal Ht As Single)
        SCrit_SideswayBraced = LCrit - 1.25 'ft
    End Function

    'BucklingSidesway below X-brace and bent over water
    Function SCrit_SideswayBracedOverWater(ByVal LCrit As Single, ByVal Ht As Single)
        SCrit_SideswayBracedOverWater = LCrit - (1.25 + WaterDepth)
    End Function

```

```

End Function

'Unbraced Buckling Sidesway
Function LCrit_SideswayUnBraced(ByVal PApplied As Single, ByVal EffInertia As Single,
ByVal C As Single)
    LCrit_SideswayUnBraced = (((C * (Pi ^ 2) * ModulusE * EffInertia) / (1.33 *
PApplied)) ^ (0.5)) / 12 'ft
End Function

Function SCrit_SideswayUnBraced(ByVal LCrit As Single, ByVal Ht As Single)
    SCrit_SideswayUnBraced = LCrit + 1.25 - Ht 'ft
End Function

End Module

```

## Appendix D.6 Bent Pushover Evaluation Module

```
Public Class PushoverEvaluation

    Private Sub ContinueButton_Click(ByVal sender As System.Object, ByVal e As
System.EventArgs) Handles ContinueButton.Click
        'Shows next form
        My.Forms.BeamColumnEval.Show()
        WindowState = FormWindowState.Minimized
    End Sub

    Private Sub PushoverEval_Load(ByVal sender As System.Object, ByVal e As
System.EventArgs) Handles MyBase.Load
        'Display previous inputs
        SpanText.Text = Span.ToString("###0.0")
        BentMaxLoadText.Text = BentAppliedMax.ToString("###0.0")
        DebrisRaftText.Text = DebrisRaft

        'Determine raft force based on bridge span length
        If DebrisRaft = "Yes" Then
            If Span <= 25 Then
                RaftForce = 8.62 'kips 'smaller raft
            Else
                RaftForce = 12.93 'kips 'larger raft
            End If
        Else
            'Minimum assumed force if no raft present
            RaftForce = 1.5 'kips
        End If

        RaftForceText.Text = RaftForce
        PLoadMax = BentAppliedMax / NoPiles
        PLoadText.Text = PLoadMax.ToString("###0.0")

        'only unsafe bent is unbraced 3-pile, 12 dia, 16ft high, P load 60, large raft,
        & and maximum scour

        If Smax > 20 Then 'out of range cases
            PushoverSafetyText.ForeColor = Color.Red
            PushoverSafetyText.Text = "Out of Range"
            PushoverCritScourText.Text = "Out of Range"
            Pushover = "Out of Range"
            MsgBox("Screening tool cannot evaluate bent pushover for scour values greater
            & than 20 feet.")
        Else
            If Bracing = "X-braced" Then
                If BentHeight > 20 Then 'out of range cases
                    PushoverSafetyText.ForeColor = Color.Red
                    PushoverSafetyText.Text = "Out of Range"
                    PushoverCritScourText.Text = "Out of Range"
                End If
            End If
        End If
    End Sub
End Class
```



```

Pushover = "Out of Range"
MsgBox("Screening tool cannot evaluate bent pushover for braced bent
& heights greater than 20 feet.")
Else
PushoverSafetyText.ForeColor = Color.Blue
PushoverSafetyText.Text = "Safe!"
PushoverCritScourText.Text = "Greater than 20ft"
Pushover = "Safe!"
End If
Else 'unbraced cases
If BentHeight > 16 Then 'out of range cases
PushoverSafetyText.ForeColor = Color.Red
PushoverSafetyText.Text = "Out of Range"
PushoverCritScourText.Text = "Out of Range"
Pushover = "Out of Range"
MsgBox("Screening tool cannot evaluate bent pushover for unbraced
& bent heights greater than 16 feet.")
Else
If Dia = 14 Then
PushoverSafetyText.ForeColor = Color.Blue
PushoverSafetyText.Text = "Safe!"
PushoverCritScourText.Text = "Greater than 20ft"
Pushover = "Safe!"
Else '12in cases
If NoPiles = 3 Then
If BentHeight > 12 Then 'ft
If PLoadMax <= 40 Then 'smaller gravity load cases
PushoverSafetyText.ForeColor = Color.Blue
PushoverSafetyText.Text = "Safe!"
PushoverCritScourText.Text = "Greater than 20ft"
Pushover = "Safe!"
Else
If Span >= 25 Then 'large raft cases
If Smax > 15 Then
PushoverSafetyText.ForeColor = Color.Red
PushoverSafetyText.Text = "Unsafe!"
PushoverCritScourText.Text = "Greater than
& 15ft"
Pushover = "Unsafe!"
Else 'smaller scour cases
PushoverSafetyText.ForeColor = Color.Blue
PushoverSafetyText.Text = "Safe!"
PushoverCritScourText.Text = "Greater than
& 20ft"
Pushover = "Safe!"
End If
Else 'smaller raft force cases
PushoverSafetyText.ForeColor = Color.Blue
PushoverSafetyText.Text = "Safe!"
PushoverCritScourText.Text = "Greater than 20ft"
Pushover = "Safe!"
End If
End If
Else 'smaller bent height cases
PushoverSafetyText.ForeColor = Color.Blue
PushoverSafetyText.Text = "Safe!"
PushoverCritScourText.Text = "Greater than 20ft"

```

```

        Pushover = "Safe!"
    End If

    Else 'other number of pile cases
        PushoverSafetyText.ForeColor = Color.Blue
        PushoverSafetyText.Text = "Safe!"
        PushoverCritScourText.Text = "Greater than 20ft"
        Pushover = "Safe!"
    End If
End If
End If
End If
'send to printing module
PushoverCritScourTextVal = PushoverCritScourText.Text
End If

End Sub

Private Sub ExitButton_Click(ByVal sender As System.Object, ByVal e As
System.EventArgs) Handles ExitButton.Click
    'Exit routine
End
End Sub
End Class

```

## Appendix D.7 Beam-Column Evaluation Module

```
Public Class BeamColumnEval
```

```
    Private Sub BeamColumnEval_Load(ByVal sender As System.Object, ByVal e As
System.EventArgs) Handles MyBase.Load
        'Show all inputs in form
        DebrisRaftText.Text = DebrisRaft
        DiameterText.Text = Dia.ToString("###0")
        XBracedText.Text = Bracing
        HeightText.Text = BentHeight.ToString("###0.0")
        ScourText.Text = Smax.ToString("###0.0")
        SpanText.Text = Span.ToString("###0.0")

        'Beam-Column Evaluations
        If DebrisRaft = "No" Then
            BeamColSafetyText.ForeColor = Color.Blue
            BeamColSafetyText.Text = "Safe!"
            BeamColumn = "Safe!"
        Else
            If Bracing = "X-braced" Then
                BeamColSafetyText.ForeColor = Color.Blue
                BeamColSafetyText.Text = "Safe!"
                BeamColumn = "Safe!"
                CritScourBeamCol = "Greater than 20ft"
                CritScourBeamText.Text = CritScourBeamCol
            Else 'Unbraced cases
                If BentHeight > 12 Then 'ft
                    BeamColSafetyText.ForeColor = Color.Red
                    BeamColSafetyText.Text = "Out of Range"
                    BeamColumn = "Out of Tool's Range"
                    CritScourBeamCol = "UNKNOWN"
                    CritScourBeamText.Text = CritScourBeamCol
                Else
                    If BentHeight > 8 Then
                        If Dia = 14 Then '14in cases; 12 to 8ft bents
                            If RaftForce <= 8.62 Then 'kips
                                If PLoad <= 44 Then 'kips
                                    CritScourBeamCol = "10"
                                    CritScourBeamText.Text = CritScourBeamCol
                                    If Smax <= 10 Then 'ft
                                        BeamColSafetyText.ForeColor = Color.Blue
                                        BeamColSafetyText.Text = "Safe!"
                                        BeamColumn = "Safe!"
                                    Else
                                        BeamColSafetyText.ForeColor = Color.Red
                                        BeamColSafetyText.Text = "Unsafe!"
                                        BeamColumn = "Unsafe!"
                                    End If
                                End If
                            End If
                        End If
                    End If
                End If
            End If
        End Sub
End Class
```

```

End If
Else 'larger p-load cases
CritScourBeamCol = "5"
CritScourBeamText.Text = CritScourBeamCol
If Smax <= 5 Then 'ft
    BeamColSafetyText.ForeColor = Color.Blue
    BeamColSafetyText.Text = "Safe!"
    BeamColumn = "Safe!"
Else
    BeamColSafetyText.ForeColor = Color.Red
    BeamColSafetyText.Text = "Unsafe!"
    BeamColumn = "Unsafe!"
End If
End If
Else 'Larger debris raft
CritScourBeamCol = "10"
CritScourBeamText.Text = CritScourBeamCol
If PLoad <= 36 Then 'kips
    If Smax <= 10 Then 'ft
        BeamColSafetyText.ForeColor = Color.Blue
        BeamColSafetyText.Text = "Safe!"
        BeamColumn = "Safe!"
    Else
        BeamColSafetyText.ForeColor = Color.Red
        BeamColSafetyText.Text = "Unsafe!"
        BeamColumn = "Unsafe!"
    End If
Else 'larger p-load cases
CritScourBeamCol = "5"
CritScourBeamText.Text = CritScourBeamCol
If Smax <= 5 Then 'ft
    BeamColSafetyText.ForeColor = Color.Blue
    BeamColSafetyText.Text = "Safe!"
    BeamColumn = "Safe!"
Else
    BeamColSafetyText.ForeColor = Color.Red
    BeamColSafetyText.Text = "Unsafe!"
    BeamColumn = "Unsafe!"
End If
End If
End If
Else '12in diameter cases
If RaftForce <= 8.62 Then 'small raft cases
    If PLoad <= 32 Then 'kips
        CritScourBeamCol = "5"
        CritScourBeamText.Text = CritScourBeamCol
        If Smax <= 5 Then 'ft
            BeamColSafetyText.ForeColor = Color.Blue
            BeamColSafetyText.Text = "Safe!"
            BeamColumn = "Safe!"
        Else
            BeamColSafetyText.ForeColor = Color.Red
            BeamColSafetyText.Text = "Unsafe!"
            BeamColumn = "Unsafe!"
        End If
    Else 'larger pload cases
        CritScourBeamCol = "0"
        CritScourBeamText.Text = CritScourBeamCol
    End If
End If

```

```

        BeamColSafetyText.ForeColor = Color.Red
        BeamColSafetyText.Text = "Unsafe!"
        BeamColumn = "Unsafe!"
    End If
Else 'larger raft cases
    If PLoad <= 20 Then 'kips
        CritScourBeamCol = "5"
        CritScourBeamText.Text = CritScourBeamCol
        If Smax <= 5 Then 'ft
            BeamColSafetyText.ForeColor = Color.Blue
            BeamColSafetyText.Text = "Safe!"
            BeamColumn = "Safe!"
        Else
            BeamColSafetyText.ForeColor = Color.Red
            BeamColSafetyText.Text = "Unsafe!"
            BeamColumn = "Unsafe!"
        End If
    Else 'larger pload cases
        CritScourBeamCol = "0"
        CritScourBeamText.Text = CritScourBeamCol
        BeamColSafetyText.ForeColor = Color.Red
        BeamColSafetyText.Text = "Unsafe!"
        BeamColumn = "Unsafe!"
    End If
End If
End If
End If

ElseIf BentHeight <= 8 Then 'ft
    If Dia = 12 Then '12in cases; less or equal to 8ft bents
        If RaftForce <= 8.62 Then 'kips
            If PLoad <= 26 Then 'kips
                CritScourBeamCol = "10"
                CritScourBeamText.Text = CritScourBeamCol
                If Smax <= 10 Then 'ft
                    BeamColSafetyText.ForeColor = Color.Blue
                    BeamColSafetyText.Text = "Safe!"
                    BeamColumn = "Safe!"
                Else
                    BeamColSafetyText.ForeColor = Color.Red
                    BeamColSafetyText.Text = "Unsafe!"
                    BeamColumn = "Unsafe!"
                End If
            Else
                CritScourBeamCol = "5"
                CritScourBeamText.Text = CritScourBeamCol
                If Smax <= 5 Then 'ft
                    BeamColSafetyText.ForeColor = Color.Blue
                    BeamColSafetyText.Text = "Safe!"
                    BeamColumn = "Safe!"
                Else
                    BeamColSafetyText.ForeColor = Color.Red
                    BeamColSafetyText.Text = "Unsafe!"
                    BeamColumn = "Unsafe!"
                End If
            End If
        Else 'Larger debris raft
            CritScourBeamCol = "5"
            CritScourBeamText.Text = CritScourBeamCol

```

```

        If Smax <= 5 Then 'ft
            BeamColSafetyText.ForeColor = Color.Blue
            BeamColSafetyText.Text = "Safe!"
            BeamColumn = "Safe!"
        Else
            BeamColSafetyText.ForeColor = Color.Red
            BeamColSafetyText.Text = "Unsafe!"
            BeamColumn = "Unsafe!"
        End If
    End If
Else '14in diameter cases
    CritScourBeamCol = "10"
    CritScourBeamText.Text = CritScourBeamCol
    If Smax <= 10 Then 'ft
        BeamColSafetyText.ForeColor = Color.Blue
        BeamColSafetyText.Text = "Safe!"
        BeamColumn = "Safe!"
    Else
        BeamColSafetyText.ForeColor = Color.Red
        BeamColSafetyText.Text = "Unsafe!"
        BeamColumn = "Unsafe!"
    End If
End If
End If
End If
End If
End Sub

```

```

    Private Sub ExitButton_Click(ByVal sender As System.Object, ByVal e As
System.EventArgs) Handles ExitButton.Click
        'Exit Routine
        End
    End Sub

```

```

    Private Sub ContinueButton_Click(ByVal sender As System.Object, ByVal e As
System.EventArgs) Handles ContinueButton.Click
        'Show next form
        If BeamColSafetyText.Text = "UNKNOWN" Then
            MsgBox("Screening tool cannot check beam column adequacy of unbraced bent
heights greater than 12 feet.")
        Else
            End If
        My.Forms.Conclusions.Show()
        WindowState = FormWindowState.Minimized
    End Sub
End Class

```

## Appendix D.8 Conclusions and Related Modules

```
Public Class Conclusions
```

```
    Private Sub ExitButton_Click(ByVal sender As System.Object, ByVal e As  
System.EventArgs) Handles ExitButton.Click  
        End  
    End Sub
```

```
    Private Sub Conclusions_Load(ByVal sender As System.Object, ByVal e As  
System.EventArgs) Handles MyBase.Load  
        'Output scour evaluations to form  
        'Eval 1: Kickout  
        If KickOut = "Unsafe!" Then  
            KickOutSafety.ForeColor = Color.Red  
            KickOutSafety.Text = KickOut  
        Else  
            KickOutSafety.ForeColor = Color.Blue  
            KickOutSafety.Text = KickOut  
        End If  
  
        'Eval 2: Plunging  
        If Plunging = "Safe!" Then  
            PlungingSafety.ForeColor = Color.Blue  
            PlungingSafety.Text = Plunging  
        Else  
            PlungingSafety.ForeColor = Color.Red  
            PlungingSafety.Text = Plunging  
        End If  
  
        'Eval 3: Buckling  
        If Buckling = "Safe!" Then  
            BucklingSafety.ForeColor = Color.Blue  
            BucklingSafety.Text = Buckling  
        Else  
            BucklingSafety.ForeColor = Color.Red  
            BucklingSafety.Text = Buckling  
        End If  
  
        'Eval4: Pushover  
        If Pushover = "Safe!" Then  
            PushoverSafety.ForeColor = Color.Blue  
            PushoverSafety.Text = Pushover  
        Else  
            PushoverSafety.ForeColor = Color.Red  
            PushoverSafety.Text = Pushover  
        End If  
  
        'Eval5: Beam-Column  
        If BeamColumn = "Safe!" Then
```

```

        BeamColumnSafety.ForeColor = Color.Blue
        BeamColumnSafety.Text = BeamColumn
    Else
        BeamColumnSafety.ForeColor = Color.Red
        BeamColumnSafety.Text = BeamColumn
    End If

End Sub

Private Sub PrintToolStripButton_Click(ByVal sender As System.Object, ByVal e As
System.EventArgs) Handles PrintToolStripButton.Click
    'Show printing form
    My.Forms.Printing.Show()
End Sub

Private Sub HelpToolStripButton_Click(ByVal sender As System.Object, ByVal e As
System.EventArgs) Handles HelpToolStripButton.Click
    My.Forms.ConclusionsHelpFile.ShowDialog()
End Sub
End Class

Public Class ConclusionsHelpFile

    Private Sub Button1_Click(ByVal sender As System.Object, ByVal e As System.EventArgs)
Handles Button1.Click
        Me.DialogResult = DialogResult.OK
    End Sub
End Class

```



## Appendix D.9 Printing Output Report Module

```
Imports TimberScour.PrintingObjects
```

```
Public Class Printing
```

```
    Private Sub PrintButton_Click(ByVal sender As System.Object, ByVal e As
System.EventArgs) Handles PrintButton.Click
        'gather info for header of printed form
        Engineer = EngineerText.Text
        BIN = BINText.Text
        CheckDate = DateText.Text
        City = CityText.Text
        County = CountyText.Text
        Notes = CommentText.Text

        Dim header As New PrintingCategory("ALDOT TIMBER STABILITY SCREENING TOOL")
        header.Items.Add(New PrintingItem("Date", Date.Now.ToString("MM/dd/yyyy")))
        header.Items.Add(New PrintingItem("BIN", BIN))
        header.Items.Add(New PrintingItem("Checked By", Engineer))
        header.Items.Add(New PrintingItem("", City & ", " & County & " County, Alabama"))

        Dim AllSections As New ArrayList()

        Dim EmptySection As New PrintingSection("Input Parameters")
        Dim BentPropertiesCat As New PrintingCategory("Bent Properties")
        BentPropertiesCat.Items.Add(New PrintingItem("Span (ft)", Span))
        BentPropertiesCat.Items.Add(New PrintingItem("Bent Height (ft)", BentHeight))
        BentPropertiesCat.Items.Add(New PrintingItem("Depth of water under bent (ft)",
WaterDepth))
        BentPropertiesCat.Items.Add(New PrintingItem("Number Of Piles", NoPiles))
        BentPropertiesCat.Items.Add(New PrintingItem("Bracing Scheme", Bracing))
        BentPropertiesCat.Items.Add(New PrintingItem("Pile Butt Diameter (in.)", Dia))
        EmptySection.Categories.Add(BentPropertiesCat)

        Dim PileDInfo As New PrintingCategory("Pile Driving Information")
        PileDInfo.Items.Add(New PrintingItem("Hammer Type", HammerType))
        PileDInfo.Items.Add(New PrintingItem("Efficiency", Efficiency))
        EmptySection.Categories.Add(PileDInfo)

        Dim EstimatedScour As New PrintingCategory("Estimated Scour")
        EstimatedScour.Items.Add(New PrintingItem("Maximum Estimated Scour (ft)", Smax))
        EstimatedScour.Items.Add(New PrintingItem("Pile Embedment BEFORE scour (ft)",
Lbg))
        EmptySection.Categories.Add(EstimatedScour)
```

```

    Dim AppliedLoads As New PrintingCategory("Applied Loads")
    AppliedLoads.Items.Add(New PrintingItem("Maximum pile applied load (unfactored
(kips)", PileAppliedMax))
    AppliedLoads.Items.Add(New PrintingItem("Maximum bent applied load (unfactored
(kips)", BentAppliedMax))
    EmptySection.Categories.Add(AppliedLoads)

    AllSections.Add(EmptySection)

    Dim StabilityEvalSection As New PrintingSection("Stability Evaluation")
    Dim KickOutCat As New PrintingCategory("Kick-out")
    KickOutCat.Items.Add(New PrintingItem("Pile Embedment AFTER scour of most
critical pile (ft)", Las))
    KickOutCat.Items.Add(New PrintingItem("Safety", KickOut))
    StabilityEvalSection.Categories.Add(KickOutCat)

    Dim BucklingCat As New PrintingCategory("Buckling")
    BucklingCat.Items.Add(New PrintingItem("Effective Moment of Inertia (in)",
IEffTextVal))
    BucklingCat.Items.Add(New PrintingItem("Buckling Mode", FailureModeTextVal))
    BucklingCat.Items.Add(New PrintingItem("Critical Buckling Length(ft)", LcrTextVal
& " (measured from the bent cap connection to the new ground line)"))
    BucklingCat.Items.Add(New PrintingItem("Critical Scour (ft)", ScourCritTextVal))
    BucklingCat.Items.Add(New PrintingItem("Safety", Buckling))
    StabilityEvalSection.Categories.Add(BucklingCat)

    Dim PushoverCat As New PrintingCategory("Pushover")
    PushoverCat.Items.Add(New PrintingItem("Raft Force (kips)", RaftForce))
    PushoverCat.Items.Add(New PrintingItem("Gravity Load (kips)", PloadMax))
    PushoverCat.Items.Add(New PrintingItem("Critical Scour (ft)",
PushoverCritScourTextVal))
    PushoverCat.Items.Add(New PrintingItem("Safety", Pushover))
    StabilityEvalSection.Categories.Add(PushoverCat)

    Dim BeamColCat As New PrintingCategory("Beam-Column")
    BeamColCat.Items.Add(New PrintingItem("Safety", BeamColumn))
    BeamColCat.Items.Add(New PrintingItem("Critical Scour (ft)", CritScourBeamCol))
    StabilityEvalSection.Categories.Add(BeamColCat)

    AllSections.Add(StabilityEvalSection)

    Dim PlungingSection As New PrintingSection(" ")
    Dim pEmptyCat As New PrintingCategory("Plunging")
    Dim PileItem As New PrintingItem("Pile")
    PileItem.Values.Add(vBentNo1)
    PileItem.Values.Add(vBentNo2)
    PileItem.Values.Add(vBentNo3)
    PileItem.Values.Add(vBentNo4)
    PileItem.Values.Add(vBentNo5)
    pEmptyCat.Items.Add(PileItem)

    Dim HammerEnergyItem As New PrintingItem("Hammer Rated Energy (lb-ft)")
    HammerEnergyItem.Values.Add(vHammerEnergy1)
    HammerEnergyItem.Values.Add(vHammerEnergy2)
    HammerEnergyItem.Values.Add(vHammerEnergy3)
    HammerEnergyItem.Values.Add(vHammerEnergy4)
    HammerEnergyItem.Values.Add(vHammerEnergy5)
    pEmptyCat.Items.Add(HammerEnergyItem)

```

```

Dim DrivingResItem As New PrintingItem("Driving Resistance (bpi)")
DrivingResItem.Values.Add(vDrivingResistance1)
DrivingResItem.Values.Add(vDrivingResistance2)
DrivingResItem.Values.Add(vDrivingResistance3)
DrivingResItem.Values.Add(vDrivingResistance4)
DrivingResItem.Values.Add(vDrivingResistance5)
pEmptyCat.Items.Add(DrivingResItem)

Dim EmbedmentItem As New PrintingItem("Embedment AFTER Scour (ft)")
EmbedmentItem.Values.Add(vLas1)
EmbedmentItem.Values.Add(vLas2)
EmbedmentItem.Values.Add(vLas3)
EmbedmentItem.Values.Add(vLas4)
EmbedmentItem.Values.Add(vLas5)
pEmptyCat.Items.Add(EmbedmentItem)

PlungingSection.Categories.Add(pEmptyCat)

Dim FrictionCat As New PrintingCategory("Friction")
Dim CapacityItem As New PrintingItem("Capacity (tons)")
CapacityItem.Values.Add(vFrictionCapacity1)
CapacityItem.Values.Add(vFrictionCapacity2)
CapacityItem.Values.Add(vFrictionCapacity3)
CapacityItem.Values.Add(vFrictionCapacity4)
CapacityItem.Values.Add(vFrictionCapacity5)
FrictionCat.Items.Add(CapacityItem)

Dim CritScourItem As New PrintingItem("Critical Scour (ft)")
CritScourItem.Values.Add(vFrictionCritScour1)
CritScourItem.Values.Add(vFrictionCritScour2)
CritScourItem.Values.Add(vFrictionCritScour3)
CritScourItem.Values.Add(vFrictionCritScour4)
CritScourItem.Values.Add(vFrictionCritScour5)
FrictionCat.Items.Add(CritScourItem)

Dim SafetyItem As New PrintingItem("Safety")
SafetyItem.Values.Add(vFrictionSafety1)
SafetyItem.Values.Add(vFrictionSafety2)
SafetyItem.Values.Add(vFrictionSafety3)
SafetyItem.Values.Add(vFrictionSafety4)
SafetyItem.Values.Add(vFrictionSafety5)
FrictionCat.Items.Add(SafetyItem)

PlungingSection.Categories.Add(FrictionCat)

Dim EndBearingCat As New PrintingCategory("End-Bearing")
Dim ebCapacityItem As New PrintingItem("Capacity (tons)")
ebCapacityItem.Values.Add(vEndBear1)
ebCapacityItem.Values.Add(vEndBear2)
ebCapacityItem.Values.Add(vEndBear3)
ebCapacityItem.Values.Add(vEndBear4)
ebCapacityItem.Values.Add(vEndBear5)
EndBearingCat.Items.Add(ebCapacityItem)

Dim ebCritScour As New PrintingItem("Critical Scour (ft)")
ebCritScour.Values.Add(vBearCritScour1)
ebCritScour.Values.Add(vBearCritScour2)

```

```

ebCritScour.Values.Add(vBearCritScour3)
ebCritScour.Values.Add(vBearCritScour4)
ebCritScour.Values.Add(vBearCritScour5)
EndBearingCat.Items.Add(ebCritScour)

Dim ebSafety As New PrintingItem("Safety")
ebSafety.Values.Add(vBearingSafety1)
ebSafety.Values.Add(vBearingSafety2)
ebSafety.Values.Add(vBearingSafety3)
ebSafety.Values.Add(vBearingSafety4)
ebSafety.Values.Add(vBearingSafety5)
EndBearingCat.Items.Add(ebSafety)

PlungingSection.Categories.Add(EndBearingCat)

Dim notesCat As New PrintingCategory("")
Dim adNotes As New PrintingItem("Additional Notes:", Notes)
notesCat.Items.Add(adNotes)

PlungingSection.Categories.Add(notesCat)

AllSections.Add(PlungingSection)

TimberPrinter.PrintSections(AllSections, header)

End Sub

Private Sub ExitButton_Click(ByVal sender As System.Object, ByVal e As
System.EventArgs) Handles ExitButton.Click
    End
End Sub
End Class

```