

Polymer/Composite Devices for Sports Injury Prevention

by

Edward Keith Snead IV

A thesis submitted to the Graduate Faculty of
Auburn University
in partial fulfillment of the
requirements for the Degree of
Master of Science

Auburn, Alabama
May 9, 2015

Copyright 2015 by Edward Keith Snead IV

Approved by

Gwynedd A. Thomas, Chair, Associate Professor of Polymer and Fiber Engineering
Peter Schwartz, Professor of Polymer and Fiber Engineering
Sabit Adanur, Professor of Polymer and Fiber Engineering

Abstract

For the safety and well being of all athletes in a high contact sport, it is in the athletes' best interest for those responsible to constantly be looking for ways to improve safety equipment such as helmets and padding. Today one of the biggest needs in player safety, especially in football, is to prevent concussions. The governing leagues of football have put sanctions and rules in place for extremely dangerous hits, but that does not prevent them from actually happening. The best countermeasure would be to improve the helmet. The purpose of this research project is to develop a new material for use in helmets to replace the current padding systems. The material produced for this research is a modification of a previous design that was used for an energy absorption layer in ballistic armors. The original material was a nonwoven fabric that is composed of aramid fibers and ultra high molecular weight polyethylene fibers. As a part of this project we are looking into new methods to manufacture a similar fabric and yield the same characteristics in a simpler process. After a new fabric has been produced, it will undergo testing in a football helmet that simulates a concussive blow to the head. This testing will be used to compare the new padding material to current padding systems. If this project is a success in creating a better padding system, then today's players as well as future players will be better protected against concussions, and possibly have less medical problems from head injuries as they age.

Acknowledgments

The author would like to express his gratitude to his advisor, Dr. Thomas, for her guidance, support, and valuable advice through every step in the completion of this research. The author is also grateful to his committee members, Dr. Peter Schwartz, and Dr. Sabit Adanur for serving on his graduate committee and for offering their suggestions and help, as well as Mr. Jeff Thompson for his technical help and suggestions with the air cannon modifications, Dr. Ralph Zee for providing funds to purchase the fibers, and Mr. Wiley Cauthen. In addition, the author would like to give thanks to the Department of Polymer and Fiber Engineering for providing support and helpful research environment. Lastly, the author would like to express his deepest appreciation to his parents and family whose love and support has always been unwavering, and to his fiancée for her love and patience during the pursuit of this degree.

Table of Contents

Abstract.....	ii
Acknowledgments	iii
List of Tables	vi
List of Figures.....	vii
1. INTRODUCTION.....	1
2. LITERATURE REVIEW.....	3
2.1 Summary.....	3
2.2 Objective	3
2.3 Concussions- the problem.....	4
2.3.1 Concussion mechanism/symptoms	4
2.3.2 Long Term effects and health risk	6
2.3.3 Current head protection.....	6
2.4 Non-woven trauma reducing fabric	10
2.4.1 US Patent 6846545 B2	11
2.4.2 Ballistic grade fibers	11
2.4.3 Needle-punching.....	13
2.4.4 Aramid and ultra high molecular weight polyethylene fibers.....	13
2.5 Manufacturing non-woven trauma reducing fabric	16
2.5.1 Manufacturing machinery.....	16
2.5.2 Previous, carded, trauma reducing non-woven fabrication process	21

2.5.3	“New” ST non-woven fabrication process.....	22
3.	EXPERIMENTAL DESIGN.....	25
3.1	Referenced Testing Methods.....	25
3.1.1	NOCSAE – Background.....	25
3.1.2	NOCSAE – Testing.....	26
3.1.3	VT-WFU SBES.....	31
3.2	Auburn Testing.....	33
3.2.1	Impact resistance (impact test).....	33
3.2.2	Air Cannon Testing.....	35
4.	EXPERIMENTAL RESULTS.....	50
4.1	Impact Resistance (impact test).....	50
4.2	Air Cannon Testing.....	54
4.2.1	GFT Data Accuracy.....	54
4.2.1	Padding material Comparison.....	57
5.	CONCLUSIONS.....	61
6.	RECOMMENDATIONS FOR FUTURE WORK.....	63
	REFERENCES.....	64
	APPENDICES.....	69

List of Tables

Table 1	Chart of selected ballistic grade fibers.....	12
Table 2	Preliminary fabric comparison.....	51
Table 3	Fabric comparisons to football helmet paddings.....	53
Table 4	Standard deviations of G-force for both sensor locations.....	56
Table 5	Padding material comparisons.....	57

List of Figures

Figure 1	Mechanism of a concussion.....	5
Figure 2	Riddell 360 helmet.....	7
Figure 3	Gladiator helmet.....	8
Figure 4	Bulwark helmet.....	9
Figure 5	Xyneth Epic helmet.....	10
Figure 6	Molecular formula for a para-aramid.....	13
Figure 7	Molecular formula for UHMWPE.....	14
Figure 8	Ideal structure of molecular chains for HM-HT fibers.....	14
Figure 9	Crystalline structures as basis for hierarchy of aramid fibers.....	15
Figure 10	Structural hierarchy of an aramid fiber.....	15
Figure 11	Schematic of Rando-Webber.....	16
Figure 12	Schematic of carding machine.....	17
Figure 13	Stripper, worker, and main cylinder contact point.....	18
Figure 14	Carder transfer to cross lapper.....	19
Figure 15	Schematic of a needle-punch machine.....	20
Figure 16	Barbed needles.....	21
Figure 17	Previous, carded fabric manufacturing process.....	22
Figure 18	“New” ST fabric manufacturing process.....	23
Figure 19	Dimensioning of NOCSAE headforms.....	28

Figure 20	NOCSAE drop testing apparatus.....	29
Figure 21	Approximate impact locations used during NOCSAE testing.....	30
Figure 22	Air cannon requirements for NOCSAE DOC.021.....	31
Figure 23	Schematic of a 6-DOF sensor.....	32
Figure 24	Instron Dynatup.....	34
Figure 25	Experimental scheme set-up.....	35
Figure 26	3-D model of air cannon apparatus.....	36
Figure 27	Compressed air cannon.....	37
Figure 28	Reservoir locking fixture.....	37
Figure 29	Test chamber.....	38
Figure 30	Cabinet sections.....	38
Figure 31	Air cannon frame.....	39
Figure 32	Headform.....	40
Figure 33	Headform base.....	40
Figure 34	Rod attachment to cannon frame.....	41
Figure 35	Headform attachment to rod.....	41
Figure 36	CED M2 chronograph.....	42
Figure 37	Tri-axial G-force Tracker accelerometer.....	43
Figure 38	G-force Tracker mounting locations on headform.....	44
Figure 39	Clay projectiles.....	45
Figure 40	Impact locations.....	46
Figure 41	Helmet padding variations.....	46
Figure 42	Padding shapes.....	48

Figure 43	Plot for material efficiency for preliminary fabric comparison.....	52
Figure 44	Plot for fabric comparisons to football helmet paddings.....	53
Figure 45	Plot showing similar data between the neck and helmet sensors for side impact.....	54
Figure 46	Plot showing differences in intensity and grouping for helmet and neck sensors.....	55
Figure 47	Plot of normalized G-force per 211 g of padding.....	58
Figure 48	Plot of normalized G-force per 100 g of padding side impact.....	59
Figure 49	Plot of normalized G-force per 100 g of padding rear impact.....	59
Figure 50	Plot of normalized G-force per 100 g of padding front impact.....	60

1. INTRODUCTION

In contact sports there is a great danger of injury assumed by all players every time they take the field, rink, or court. Because of these dangers it has become commonplace for most of these sports to use protective equipment. While early pieces of equipment were often crude and ineffective, throughout the years, changes and improvements have been made to them to increase their effectiveness. No matter the improvements, many pieces of equipment are still far from perfect. The research presented herein is directed towards helping improve protective equipment performance.

American football is one of the most violent, injury-prone sports in the world, and because of this, the players wear many items of protective gear. The sport is also one of the most popular in the nation, resulting in many kids of all ages playing the sport. Because of its popularity, a rise in head trauma awareness, and its violent nature, the need for better head protection is becoming greater than ever.

The aim of this thesis is to modify the production process of a previously designed trauma reducing fabric and implement this fabric into the design of American football helmets. The fabric padding is then tested against current helmet designs and the original trauma reducing fabric. The fabric padding proposed is a needle punched non-woven blend of Spectra® and Twaron® fibers. The results of the experiment are analyzed to determine the effectiveness of the fabric in this application.

In order to test the proposed helmet padding, a low-velocity air cannon in the impact testing labs of Auburn University Polymer and Fiber Engineering, was modified for the experiment. The cannon enclosure was fitted for a new velocity measurement system, a head form with data acquisition system, and a head form mounting system so that our testing apparatus was similar to existing testing standards.

2. LITERATURE REVIEW

2.1 Summary

As a solution to the problem of trauma resulting from the transfer of momentum through a bullet resistant vest, even after the projectile has been stopped, a trauma reducing nonwoven material was created and patented in 2005. This fabric is very lightweight and absorbs a great deal of energy to prevent the transfer of trauma to the body of the vest wearer. The fabric is designed to use the characteristics of high-modulus polymers and the random nature of a nonwoven fabric to redirect the energy from the collision away from the body.

The proposed product uses the ideas and theories behind this original trauma reducing nonwoven fabric, but has changed the steps used in its manufacturing so that the production of the material will be easier and more cost efficient. After fabric production modifications, testing will be done to compare the efficiency of the new fabric prototype to samples of the old carded fabric as well as materials currently used in football helmets.

2.2 Objective

This project is directed toward creating a new manufacturing process for the non-woven trauma reducing fabric technology as described in US Patent 6,846,545 B2. The intent of the modified process is to make the fabric easier to manufacture.

Once the modified process was optimized and the resulting product is of a satisfactory quality, the fabric was implemented in the padding system of a football helmet. The helmet

padding systems will be tested to standards similar to those implemented by governing agencies and other concussion related research projects. The objective of this testing is to determine if the new or old carded non-woven fabric is a suitable material to be used in padding used to protect athletes from concussive blows.

2.3 Concussions- the problem

Many different injuries can plague contact sports, but few are as dangerous or life threatening as brain injuries. The most common is a very hot topic in the sports world right now, the concussion.

2.3.1 Concussion mechanism/symptoms

A concussion is defined by Merriam-Webster dictionary as, “a condition resulting from the stunning, damaging, or shattering effects of a hard blow; *especially*: a jarring injury of the brain resulting in disturbance of cerebral function and sometimes marked by permanent damage” [1]. A simpler definition, perhaps more accurate, would be a bruise to the brain. In a collision the head is forced back while the brain, which is suspended in cerebrospinal fluid, stays still. If the collision is severe enough the fluid is compressed enough so that the brain then collides against the front of the skull. This blow causes damage to the brain. This series of events is shown below in Figure 1.

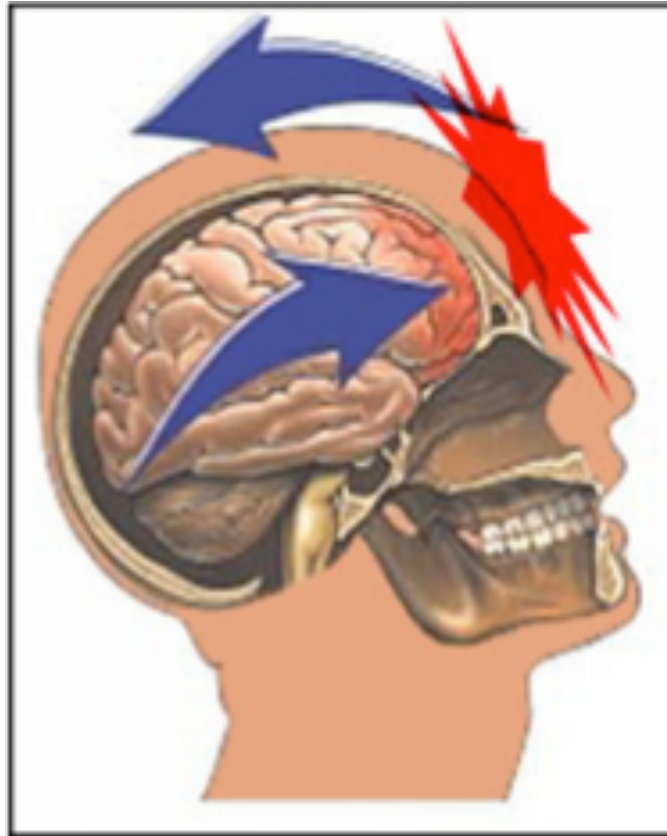

Figure 1 **Mechanism of a concussion** [2]

Signs and symptoms of a concussion may include: headache or a feeling of pressure in the head, temporary loss of consciousness, confusion or feeling as if in a fog, amnesia surrounding the traumatic event, dizziness, ringing in the ears, nausea, vomiting, slurred speech, delayed response to questions, appearing dazed, and fatigue. Some symptoms of concussions may be immediate or delayed in onset by hours or days after injury, such as: concentration and memory complaints, irritability and other personality changes, sensitivity to light and noise, sleep disturbances, psychological adjustment problems and depression, disorders of taste and smell. Symptoms of a concussion can last for several days [3]. It is suggested that any athlete that shows signs of a concussion not return to play until symptoms go away or the athlete is cleared

to play by a medical professional. And many leagues have protocols surrounding concussive events that include a mandatory number of days for recovery.

2.3.2 Long Term effects and health risk

There are many disputes about the long-term effects of concussion, as it is currently the center of a major lawsuit between retired NFL players and the National Football League, and there is still much research to be done to know more about how concussions can affect a person later in life.

It is, however, accepted that the chances of a person having another concussion are greatly increased after their first concussion, and each concussion potentially causes longer lasting more progressive effects. After a concussion, the chances of being diagnosed with epilepsy are doubled. A person also has higher chances of developing vertigo [3]. There are also many studies that suggest that repetitive concussions can lead to dementia related syndromes later in life such as Alzheimer's disease [4]. Other studies suggest that the number of concussions is not the only contributing factor, but that age is a very significant factor as well. A recent study claims that ex-NFL athletes that started playing at ages younger than 12 performed much worse on cognitive testing than those that started playing later in life [5].

2.3.3 Current head protection

For this study the focus will be on protection in American football. The basic football helmet design, until recent years, has been basically the same, unchanged concept since the 1980's. This design consists of a hard plastic shell with soft thermoplastic polyurethane, TPU, foam padding

inside and a metal or plastic facemask bolted or screwed to the front. This two-layer helmet system has been the standard for years. Substantially there have been slight improvements, however the basic ideology has not changed significantly [6].

There are several promising designs that have been released to attempt to replace the old helmet design. One of them is Riddell's attempt at a safer helmet, the Riddell 360 (Figure 2). The 360 has made several significant updates to the conventional two layer system: first it removed some fasteners from the facemask and created a new fastening system that allows for more flex in the facemask, which results in energy dispersion. Riddell also made several padding adjustments, mostly in how the helmet fits to a player's head, which helps as well [7]. Even though Riddell claims these changes are revolutionary, they still follow each change with the statement that no helmet can prevent a concussion.



Figure 2 **Riddell 360 helmet** [7]

The Schutt XP series helmets use technological improvements that are similar to the Riddell 360. They have a new system for attaching the facemask to the helmet. But the biggest difference

is the TPU absorbance system used that, in its 3rd generation, does not use a foam spacer, but instead uses a blue plastic insert with hollow conical shapes to pad the helmet. Independent tests show that it absorbs at least 12% more impact than its competitors [8].

Another, new solution is the Gladiator helmet (Figure 3). Unlike the conventional two-layer helmet, this helmet is constructed with a three-layer system. The Gladiator has a soft foam outer layer, with a hard shell middle layer and soft foam padding on the inside. This helmet is an example of a conceptually ideal system for energy absorption and is still awaiting approval before it can be used on the field [9].



Figure 3 **Gladiator helmet** [9]

Another revolutionary model that is making an impression in this discipline is the Bulwark helmet model (Figure 4). This helmet looks more conventional, with a hard outer shell, but the big difference is that this shell is divided into sections instead of one solid piece. Underneath this hard shell is a proprietary, multi-layer system that helps absorb the energy from the blows [10].



Figure 4 **Bulwark helmet [10]**

The sectional outer shell is a concept that seems to be catching the eyes of designers. Riddell released the Speedflex model in 2014 that has a flexible panel in the front. The helmet was used by many colleges during the 2014-2015 season and earned a 5-star rating on Virginia Tech's helmet rating system [11].

One last helmet that is rising in popularity and uses a unique, revolutionary system is the Xyneth Epic (Figure 5). This helmet uses a "shock absorber" technology that releases air to absorb the impact as well as a revolutionary strapping system that tightens to both the chin and back of the neck that is separate from the helmet shell itself [12].

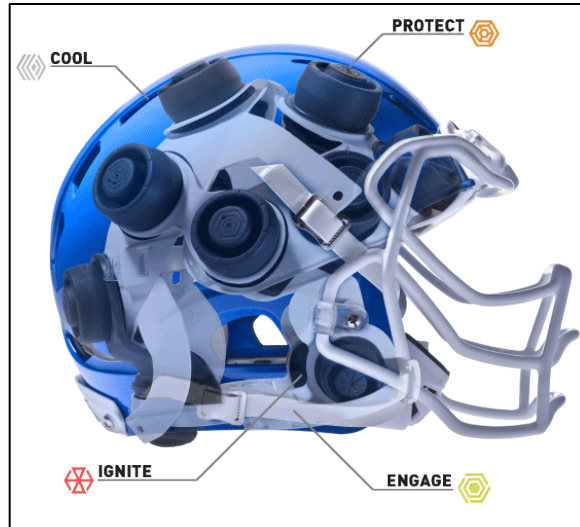

Figure 5 Xyneth Epic helmet [12]

The above examples are all improvements that have come about in the past few years as a result of the rise in concussion awareness and in an attempt to reduce the severity and frequency at which concussions occur on the field.

2.4 Non-woven trauma reducing fabric

This thesis project's roots started with the invention of a trauma reducing non-woven fabric that was developed for the purpose of reducing the trauma transferred to the body after the impact of a bullet with body armor. This fabric technology is covered in US Patent 6846545 B2, by Dr. Gwen Thomas, which is owned by Auburn University. The purpose of this project is to modify the manufacturing process of the original fabric and then repurpose the fabric to athletic protective equipment, with a focus on football helmets.

2.4.1 US Patent 6846545 B2

The patent referenced describes the fabric as, “a needle-punched, non-woven material including at least one type of ballistic fibers selected and oriented to provide a cushioning effect and maintain a high compressive restitution constant. A percentage of the fibers are oriented with at least their ends lying approximately perpendicular to the fabric plane and/or oriented to lie in a waveform generally along or parallel to the fabric plane. This enables the ends of the fibers lying perpendicular to the fabric plane to cushion the impact from the projectile by dissipating energy through compressional resistance, and the fibers along the fabric plane to reduce energy through dispersal along fiber lines, thereby reducing the trauma resulting from an impact” [13].

This patent specifies three items that are essential to the project. The first being the use of ballistic, high-modulus, high-tenacity (HM-HT) fibers, the second being the needlepunch technique, and the third being the denier of fiber used.

2.4.2 Ballistic grade fibers

Ballistic grade fibers are preferred for this fabric application because their respective high moduli and stiffness values are integral to the performance of the fabric. Fibers that would qualify into this category are usually high-modulus, high-tenacity fibers. A few examples of HM-HT fibers are: high-tenacity polyamides, aramids, carbon fibers, nylon, glass, ultra high molecular-weight polyethylene (UHMWPE), high-modulus polyester, aniline-based fibers, PBO (Poly(p-phenylene-2,6-benzobisoxazole)), natural and/or synthetic spider silk, liquid-crystalline fibers, or others as specified in the patent [13]. Table 1 shows a select few of these ballistic grade fibers and compares their properties and gives some end uses for the fiber.

Table1 Chart of selected ballistic grade fibers [13]

Fiber Type	Breaking tenacity (grams/denier)	Breaking elongation %	Initial Modulus (grams/denier)	End Use
Carbon	10.8 - 24.1	0.4 - 1.6	1500 - 3000	Aircraft/Autos/ Sporting goods
Nylon 6,6 (PA)	2.9 - 7.2	30 - 90	10 - 45	Apparel
Polyethylene (High performance)	30 - 35	2.7 - 3.6	1400 - 2000	Ballistic Resistance/ High strength fabrics and yarns
Glass	9.6 - 19.9	3.1 - 5.7	310 - 380	Technical fabrics/furniture/boats
Aramid (Para)	18 - 26.5	1.5 - 4.0	500 - 1100	Ballistic Resistance/ High strength fabrics and yarns
Poly (P-phenylene-2,6-benzobisoxazole)	42	2.5 - 3.5	1300 - 2000	Ballistic protection/ Fire Resistant

We can eliminate certain fibers because of the application; such as carbon and fiberglass which both irritate skin. PBO is not of interest because it has a track record of its strength properties degrading over time as seen with its short-term use in bulletproof vest before recall [14]. This leaves us with aramids, UHMWPE, and liquid crystalline polymer fibers as top choices. To compare these fibers we will look at the tensile modulus, which measures strength, dependent on the chain modulus and molecular orientation, measured in gigapascals (GPa) [15]. These modulus values range from 171 GPa for Spectra 1000 fibers, a popular UHMWPE, 110 GPa for Twaron 2200, a popular aramid, and 91 GPa for Vectran, a liquid crystalline polymer fiber [16]. Based on these values the best options for the nonwoven fabric would be a blend of aramid and UHMWPE fibers.

2.4.3 Needle-punching

The method used in manufacturing of a non-woven fabric greatly influences the way that it behaves under compressive strains. For this reason needle punching is the process used to give the trauma reducing fabric its structural integrity. The needle punching method allows the fabric to have the desired web density and fiber entanglement without compromising the fibers individual properties, the way other methods such as thermal bonding could [17].

2.4.4 Aramid and ultra high molecular weight polyethylene fibers

The aramid fiber that would work best for the application of the desired fabric is a para-aramid (Figure 6). Belonging to the polyamide family of fibers but with amide links formed between aromatic rings as shown in Figure 6. This chemistry allows very rigid, long chain structures with high modulus, high tensile strength and high temperature resistance. Two typical aramids used in ballistic resistant fabrics are DuPont Kevlar® and Teijin Twaron® [13].

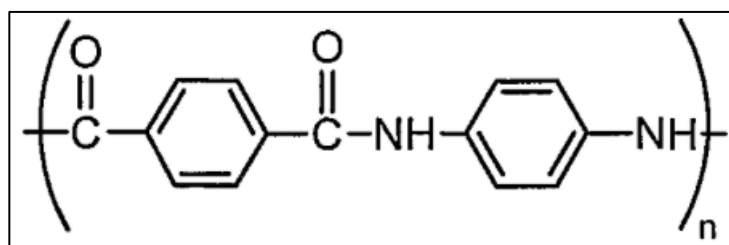

Figure 6 Molecular formula for a para-aramid [18]

UHMWPE is the second fiber that is used in the manufacturing of the fabric. UHMWPE is an additive polymer based on simple carbon-to-carbon links as shown in Figure 7. Such fibers have extremely linear molecular chains, resulting in very high parallel orientation and

crystallinity. This fiber type has very low specific gravity and tensile strength 15 times greater than steel. This family of fibers includes Dyneema® products from DSM and Spectra® products from Honeywell [13].

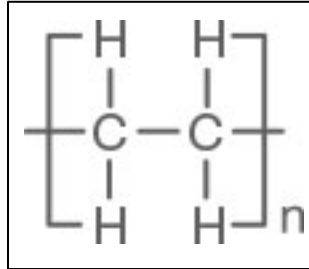

Figure 7 **Molecular formula for UHMWPE [19]**

Both of these fibers have the desired characteristics of a HM-HT fiber. The linear nature of these polymers, with little to no branching off the backbone, are perfect for obtaining the highly linear orientation along the axis of the fiber. Which is the ideal structure for molecular chain configuration of a HM-HT fiber (Figure 8) [15].

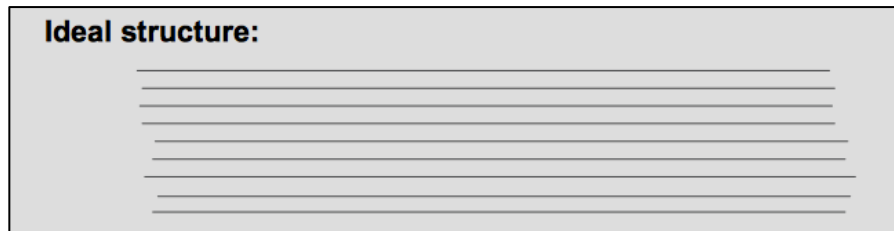

Figure 8 **Ideal structure of molecular chains for HM-HT fibers**

This ideal structure is the basis of a structural hierarchy (Figures 9 &10) that results in a very high crystalline percentage for the fiber. This high crystallinity results in the high modulus, stiffness, and tenacity values that are so desired in the fiber [15].

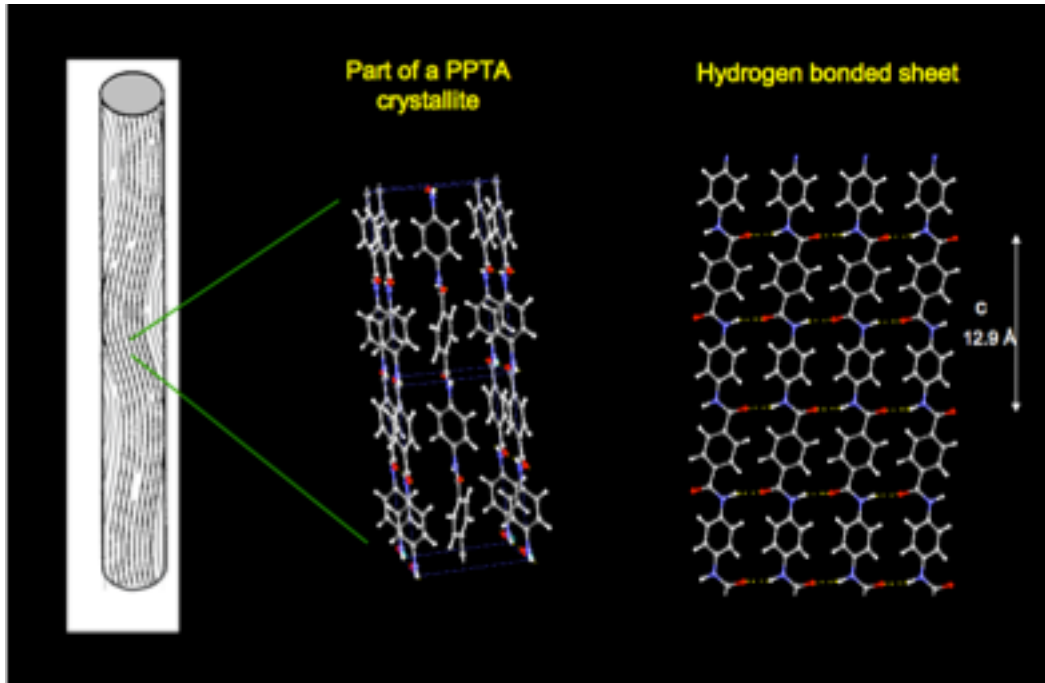

Figure 9 Crystalline structures as basis for hierarchy of aramid fibers [15]

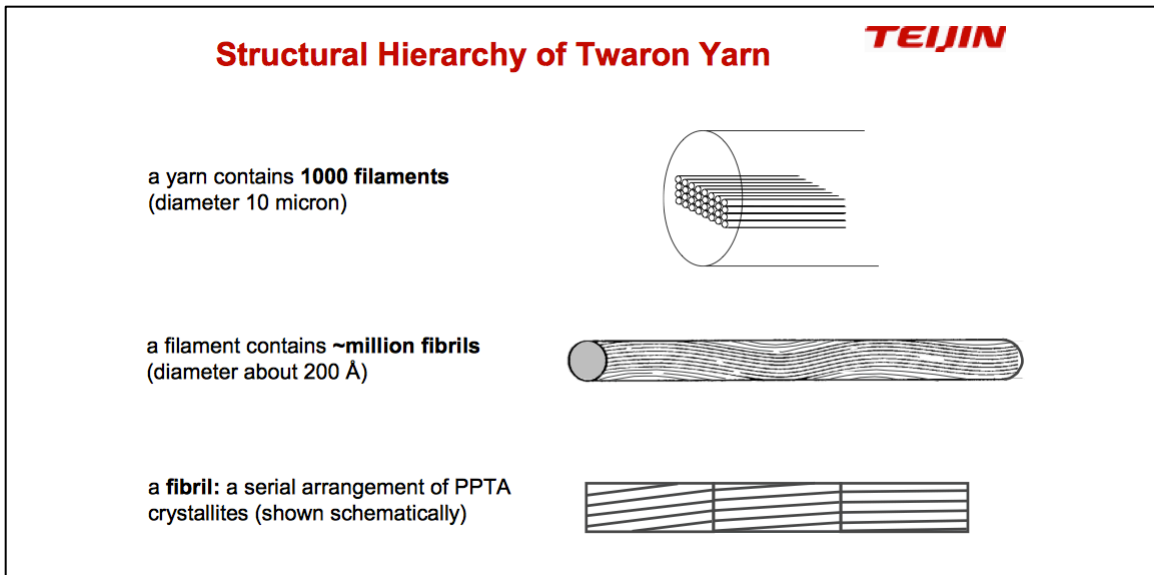

Figure 10 Structural hierarchy of an aramid fiber [15]

2.5 Manufacturing non-woven trauma reducing fabric

Manufacturing is where actual formation and production of the non-woven trauma reducing fabrics takes place.

2.5.1 Manufacturing machinery

To understand how the changes made to the manufacturing process affect the final product, one first needs to know what the machines that are used in production do, and how they work.

Rando-Webber

The Rando-Webber (Figure 11) is a machine made by Rando Machine Corporation. The machine takes opened fiber and holds it in the section called the rando feeder; this section then delivers the fibers to the air bridge via delivery aprons. The fiber then moves via the feed roll through the lickerin to the condenser for forming rando web. The web is formed on the condenser and transferred out of the machine on the delivery conveyor [20].

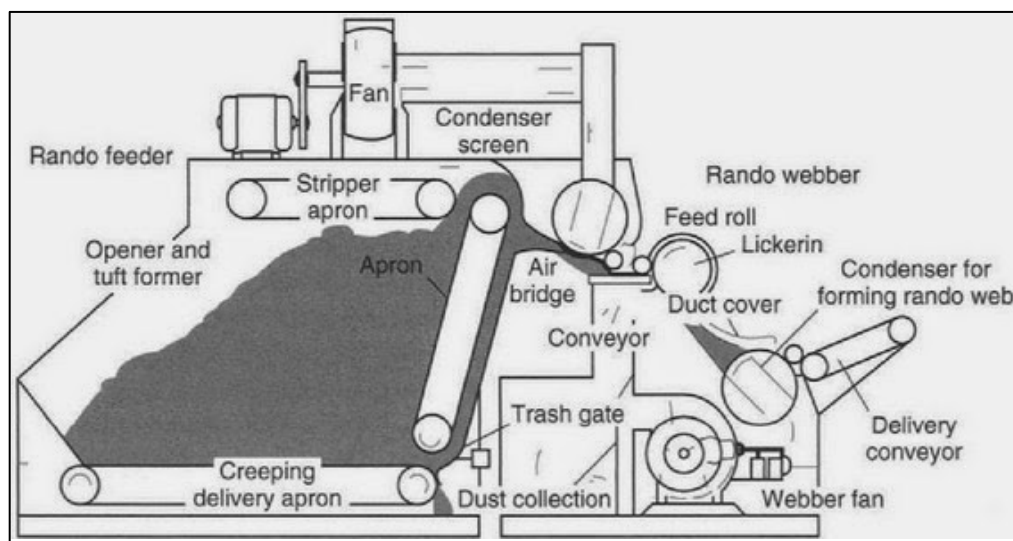

Figure 11 Schematic of Rando-Webber [20]

Changing the speeds of the aprons, feed roll, lickerin, delivery conveyor, and/or the air flow created by the fans, are all factors that can be controlled to change the thickness and density of the web produced by the machine.

Carding Machine

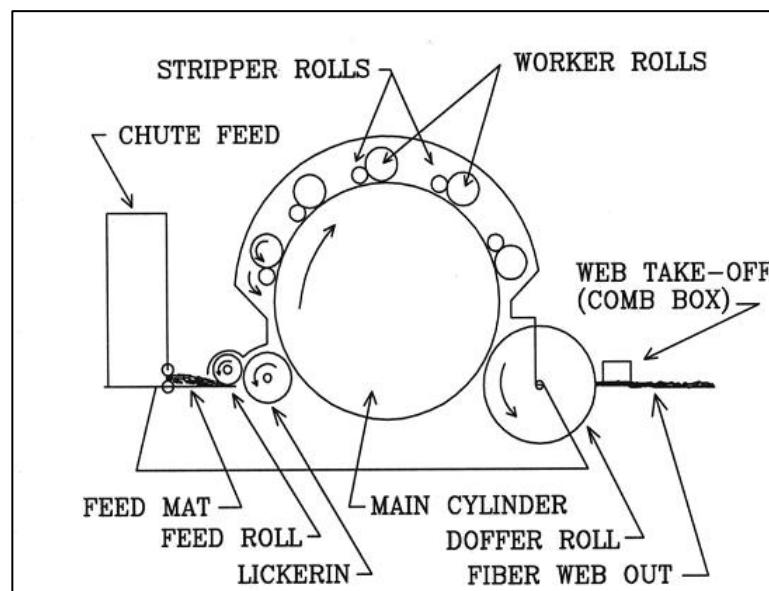

Figure 12 Schematic of a carding machine [21]

The carding machine (Figure 12) is used in non-woven manufacturing to separate small tufts of fibers into individual fibers. The machine works by taking a random assortment of fibers from the chute feed via the mat feed to the lickerin. The lickerin transfers the mat to the main cylinder. The main cylinder is covered in a carding cloth, which is made of fine metal teeth and wires. As the fibers make their way around the cylinder the teeth of the worker and stripper rolls and main cylinder comb them as shown in Figure 13. The doffer roll then transfers the fibers to the

stripping roller where the fiber web is now a thin sliver of fibers that have been mostly oriented in the direction of the manufacturing line by the combing process of the carding machine [21].

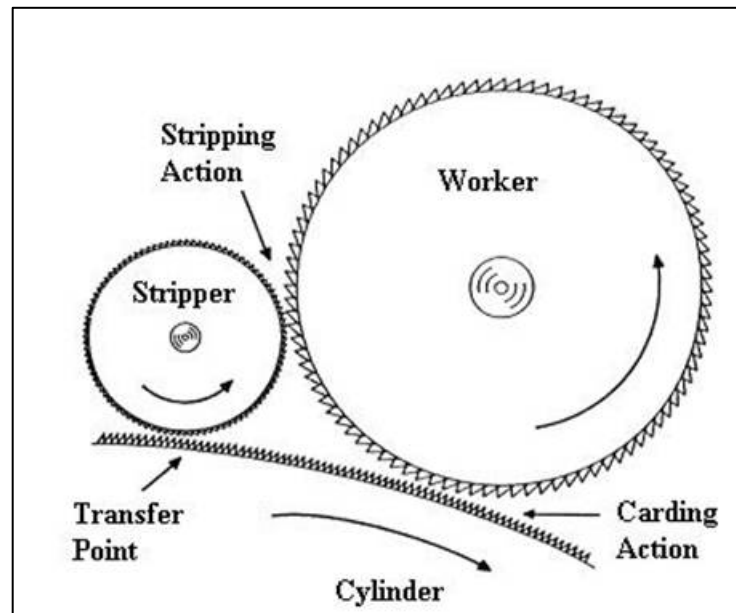

Figure 13 Stripper, worker, and main cylinder contact point [21]

Cross Lapper

After the web comes out of the carder it is very thin, so in order to get the web to the desired thickness the web is cross lapped, which is a fairly simple process. The non-wovens line at Auburn has a vertical, or camel-back, cross lapper as pictured in Figure 14. The thin web is transferred in the plane of the page to an inclined conveyor. The conveyor transfers to the pendulum conveyor that sways back and forth in the plane of the page. The web is then laid onto the perpendicular conveyor that is moving out of the page [21]. The thickness of the web is controlled by the speed of the perpendicular conveyor, and the distance the pendulum conveyor is set to swing controls the width.

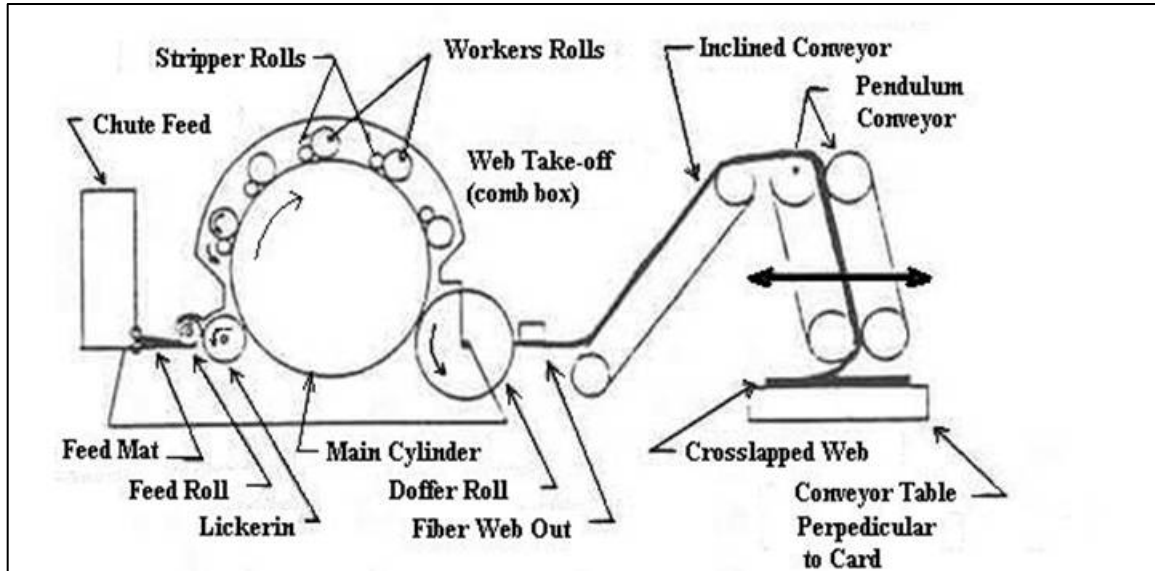

Figure 14 Carder transfer to cross lapper [21]

Needlepunch Machine

Needlepunching is the process in which the fabric gets its structural integrity. Before needlepunching the fibers form a loose web of very little structure, similar to a fluffy cotton candy, that could very easily be pulled apart by one's hands. A schematic of a needle-punch machine can be seen in Figure 15 working from right to left. The fiber web is taken into the machine by the feed rolls, where it is then "punched" by barbed needles (Figure 16). The web is consolidated into the fabric by the punching process, and the final product is taken off the machine by the draw off rolls to the wind-up/doffing process [22].

Depending on the desired characteristics of the final product several factors can be modified on the machine. First the speed of the feed rolls will determine the punch density of the fabric, this can also be modified by the number of needles that are on the needle board which can be changed as desired. Number and location of barbs and tapers on the needle are modified for

different fiber types and for desired fabric properties. These modifications ensure optimal results in production.

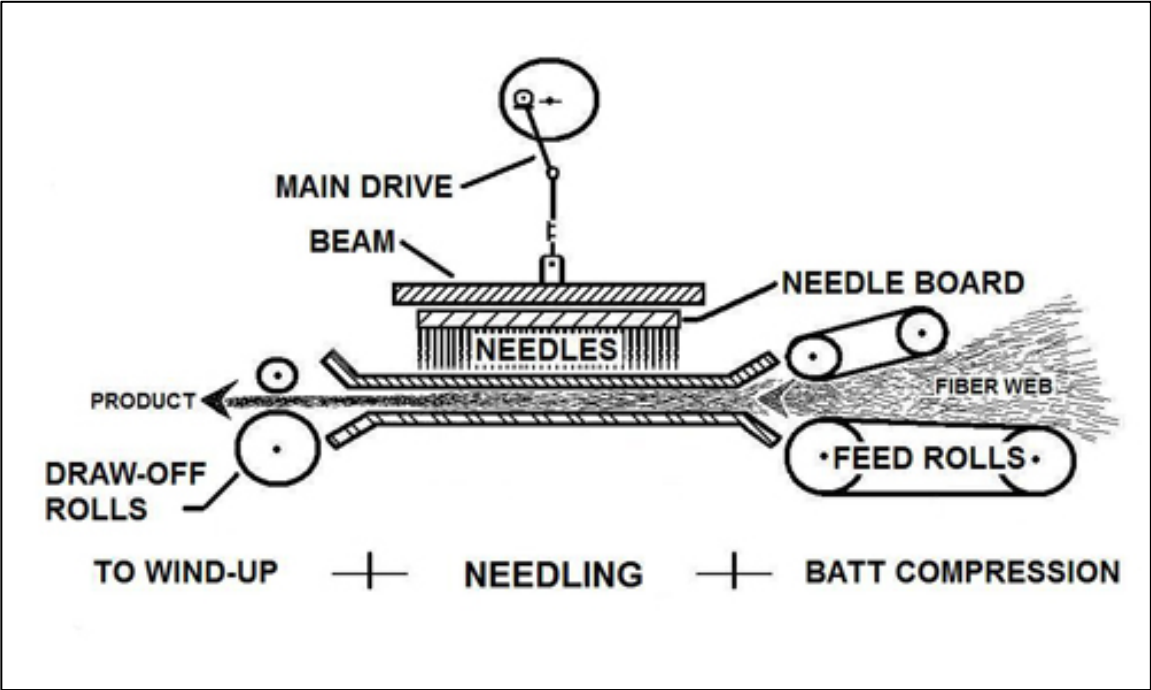

Figure 15 Schematic of a needle-punch machine [22]

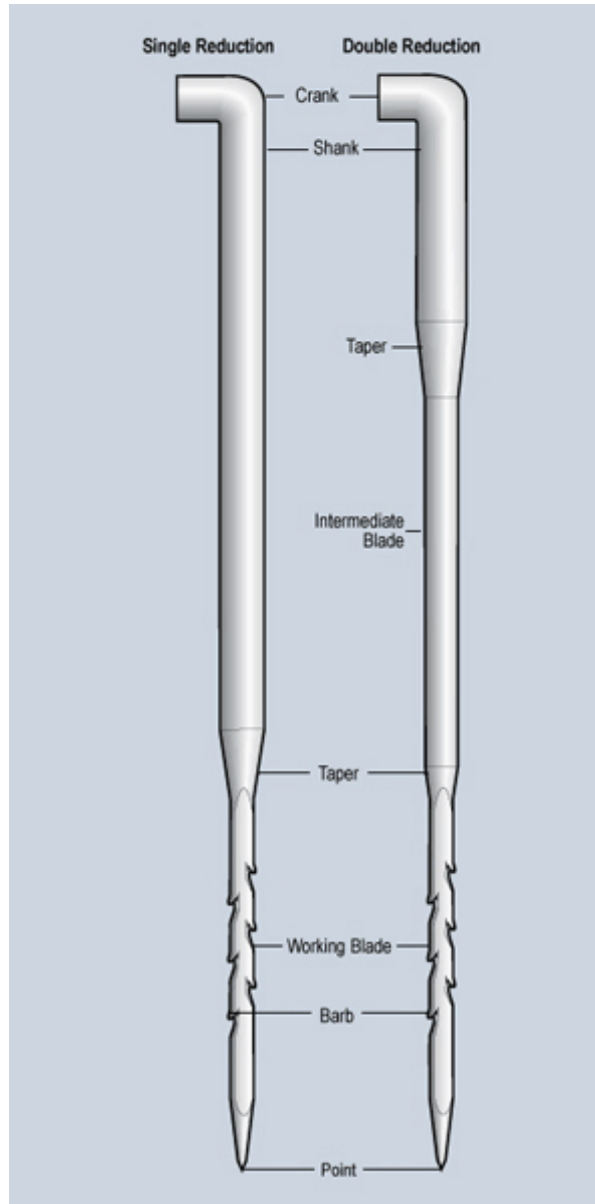

Figure 16 **Barbed needles** [22]

2.5.2 Previous, carded, trauma reducing non-woven fabrication process

The early version of the trauma reducing fabric takes advantage of the material characteristics of aramid fibers, and therefore was made using DuPont's Kevlar® 29, 1.5" staple fibers. The fabric was made using the process pictured in Figure 17. By taking the staple fibers and processing them through the Rando-webber, taking the web and running it through the

carding machine, after the carded web is thin, thus obtaining the desired thickness, the web is cross lapped before being taken to the needle-punch machine.

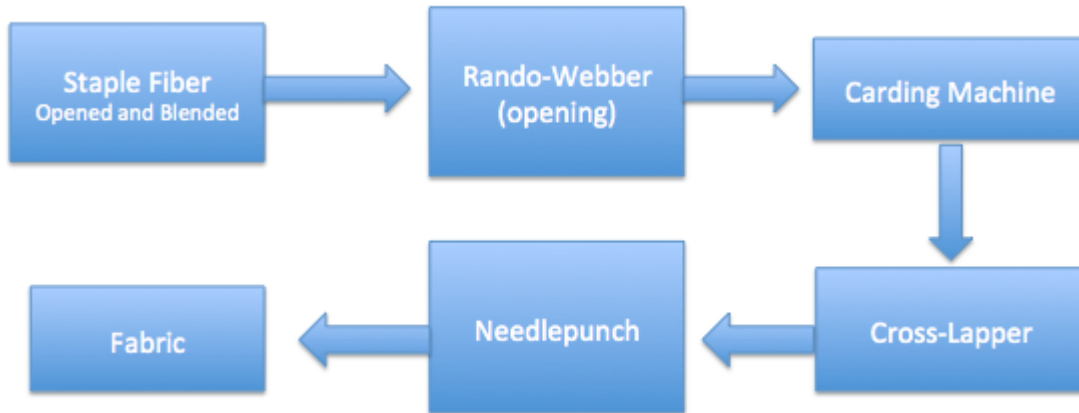

Figure 17 Previous, carded fabric manufacturing process

2.5.3 “New” ST non-woven fabrication process

The new fabric is designed to replace the old carded fabric process. Aramid and UHMWPE materials are used in this version instead of only Kevlar®. This fabric uses Teijin’s Twaron® for the aramid fiber and Honeywell’s Spectra® fibers as the UHMWPE. The fabric is a 50/50 blend by weight of Spectra® and Twaron® 1.5-inch staple fibers. The fibers were sent to TenCate located in Senoia, GA to be opened and blended because Auburn does not have the machinery to perform this task.

The process used to manufacture the ST fabric is pictured in Figure 18. The change from the “old” method to the “new” method supplants the carding process. This change also eliminates the need to cross-lap the web, so the fiber bypasses two steps and runs directly from the Rando-Webber to the needle-punch machine.

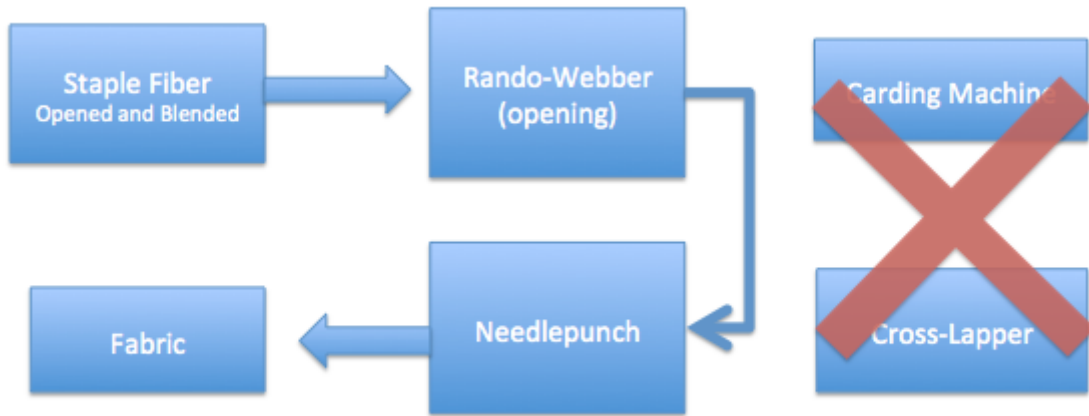

Figure 18 “New” ST fabric manufacturing process

The carding step was taken out because it is essentially unnecessary. The carding process aligns the fibers in the web and gives them all a common direction, which is then somewhat randomized by the needle punching. The non-woven fabric is so good at reducing trauma because the random nature of the fibers diverts the energy away from the target, dissipating the energy [23][24]. By removing the carding step the web is now more random before the needle-punching step, and in theory will be more random after as well, thereby having the capability to perform better at dissipating the energy of the collision.

Removing the carding step is also beneficial in reducing cost of production. By reducing the steps necessary, the possibilities of errors or defects in production are decreased, and by removing carding the waste potential are greatly reduced. Also two machines are taken out which immediately reduces the time, manpower, and floor space required on the production line. There will be further savings from possible machine repairs and maintenance. This simple

change can reduce production cost significantly, which in turn allows the product to be sold for less, or for increased profit margins on top of the theoretical mechanical improvements.

3. EXPERIMENTAL DESIGN

3.1 Referenced Testing Methods

To develop the test method used in this thesis, two major sources were studied and their standards were modified and applied to our test. The first source studied was the National Operating Committee on Standards for Athletic Equipment (NOCSAE). This committee holds the standard that every piece of athletic equipment has to pass to be used on the field or court for all high school leagues and NCAA sports [25]. The second source is The Center for Injury Biomechanics of Virginia Tech and Wake Forest (VT-WFU SBES). This center has partnered with Riddell to use a helmet mounted accelerometer system to collect actual in game data for head acceleration, and also releases the STAR rating system that ranks the best available helmets on the market [26] [27].

3.1.1 NOCSAE – Background

NOCSAE was created in 1969 in an effort to reduce the number of serious injuries and deaths that were resulting because of the rising popularity of American football. With a documented 38 deaths resulting from head or neck injuries that occurred on field in the 1968 season, the founders of NOCSAE decided that the athletes would benefit from a safety standard requirement for their protective equipment, and started a research effort was targeted towards football helmets. Several years after the implementation of NOCSAE's helmet standards for high school and collegiate football there was an 88% reduction in serious head trauma from on field injuries [25].

NOCSAE's standards have been very successful in satisfying their original mission, and this success should be noted. However, the standard was designed to prevent significant brain trauma and life-threatening head injuries such as skull fractures. As these types of injuries have virtually been eliminated from the game as technology has rapidly advanced, the NOCSAE standard has failed to be modified to a higher level. Therefore, more minor head traumas such as concussions that plague the game still occur frequently on the field when equipment is being used that has passed NOCSAE testing. This flaw needs to be noted, but the testing methods used are still very relevant to the design of this experiment.

3.1.2 NOCSAE – Testing

In the development of the procedure to be used in this thesis, two NOCSAE tests were studied. The first was the NOCSAE DOC.001, *Standard Test Method And Equipment Used In Evaluating The Performance Characteristics of Protective Headgear/Equipment*, this is the football helmet drop test standard that is applied to all helmets used in play. The second is NOCSAE DOC.021, *Standard Projectile Impact Test Method and Equipment Used In Evaluating the Performance Characteristics of Protective Headgear Faceguards or Projectiles*, which is a sub document of DOC.001 in which the method uses an air cannon apparatus, similar to the setup available at Auburn University Polymer and Fiber Engineering.

NOCSAE testing uses a Severity Index (SI) as the standard for passing their testing. The SI, “is a measure of the severity of impact with respect to the instantaneous acceleration experienced by the headform as it is impacted. Acceptable SI levels measured during impact cannot exceed

the limit specified in the individual standard performance specification” in order to pass the standard [28].

The Severity Index is defined as:

$$SI = \int_0^T A^{2.5} dt$$

Where: A is the instantaneous resultant acceleration expressed as a multiple of g (acceleration of gravity); dt is incremental time expressed in seconds, and the integration is carried out over the essential duration (T) of the acceleration pulse. The time must begin after the system triggers, but before the initial signal rises above 4 g’s. The integration must then end when the signal falls below 4 g’s, after it has peaked [28].

NOCSAE DOC.001

“The purpose of this test method is to provide reliable and repeatable measurements for the evaluation of various types of protective headgear/equipment. This test method is based on pass/fail criteria only. A passing headgear/equipment is able to withstand the impact at an acceptable SI and meets all other requirements of the Performance Specifications when tested in accordance with this test method.” [28].

The testing begins with the NOCSAE headform apparatus, and data collection devices being properly calibrated to the standards set by the test. Then the helmet is fitted to the appropriate NOCSAE headform, small, medium, or large. The helmet fit is done in accordance to designer recommendations. The headform is then raised to the appropriate height to reach an appropriate impact velocity, which is set by the standards for the specific test for the equipment being tested.

If the impact velocity is not in the appropriate range the data is labeled “indeterminate” and taken again. The test is repeated until a statistically relevant amount of data points are collected at multiple impact locations (Figure 21). The data collected in the test are from a tri-axial accelerometer that is attached in the headform. This acceleration value is then applied to the SI equation where index values less than 1200 pass and greater than 1200 fail the testing [28].

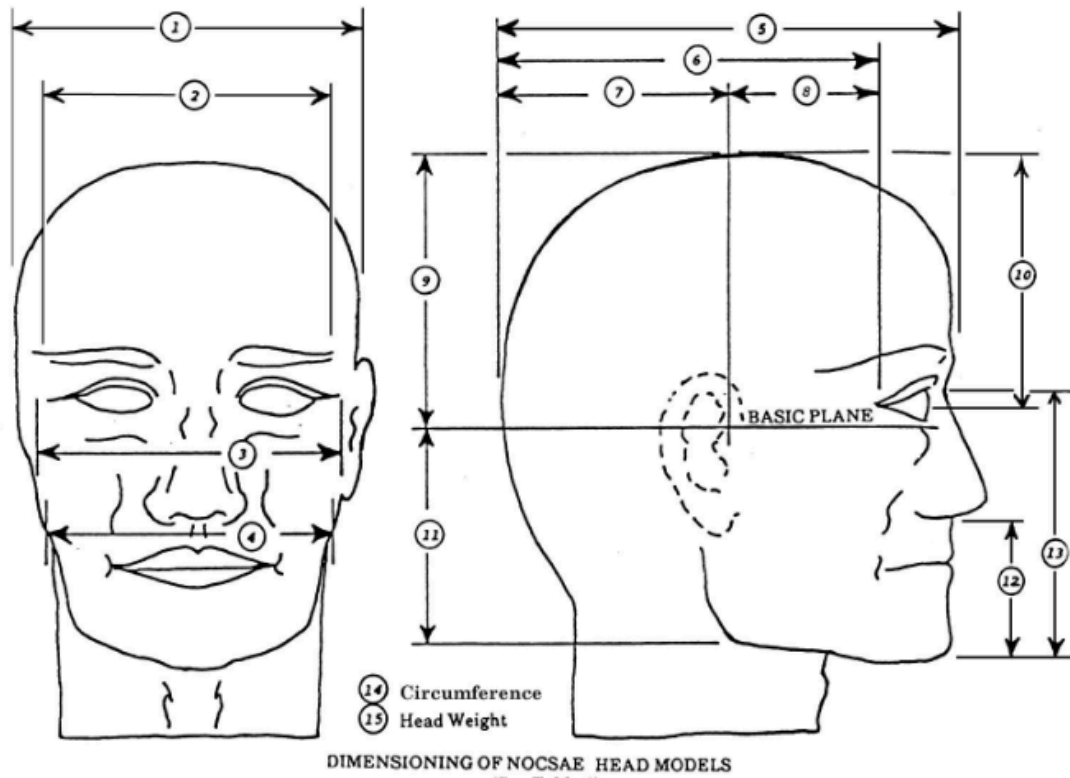

Figure 19 Dimensioning of NOCSAE headform [28]

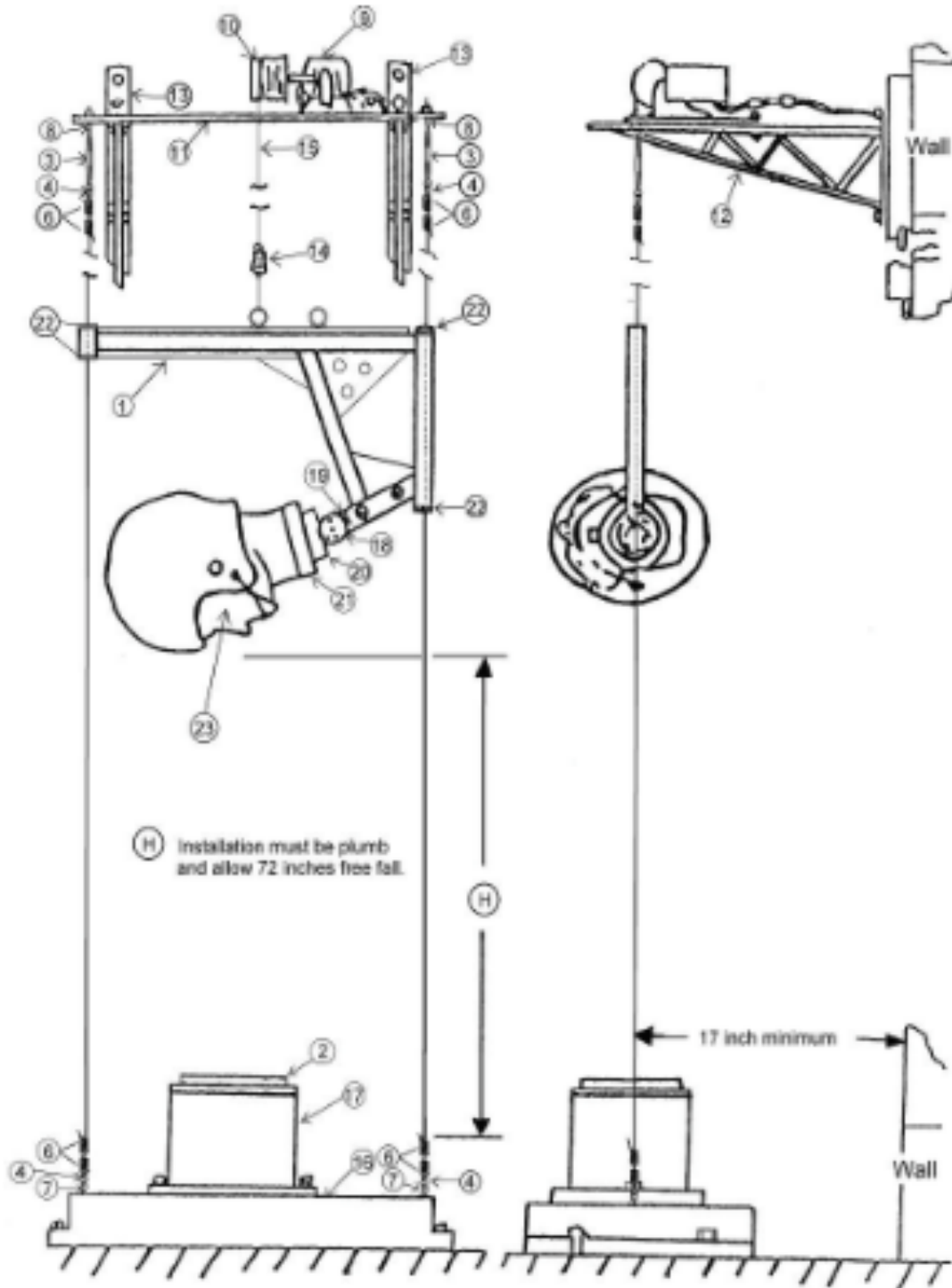

Figure 20 NOCSAE drop testing apparatus [28]

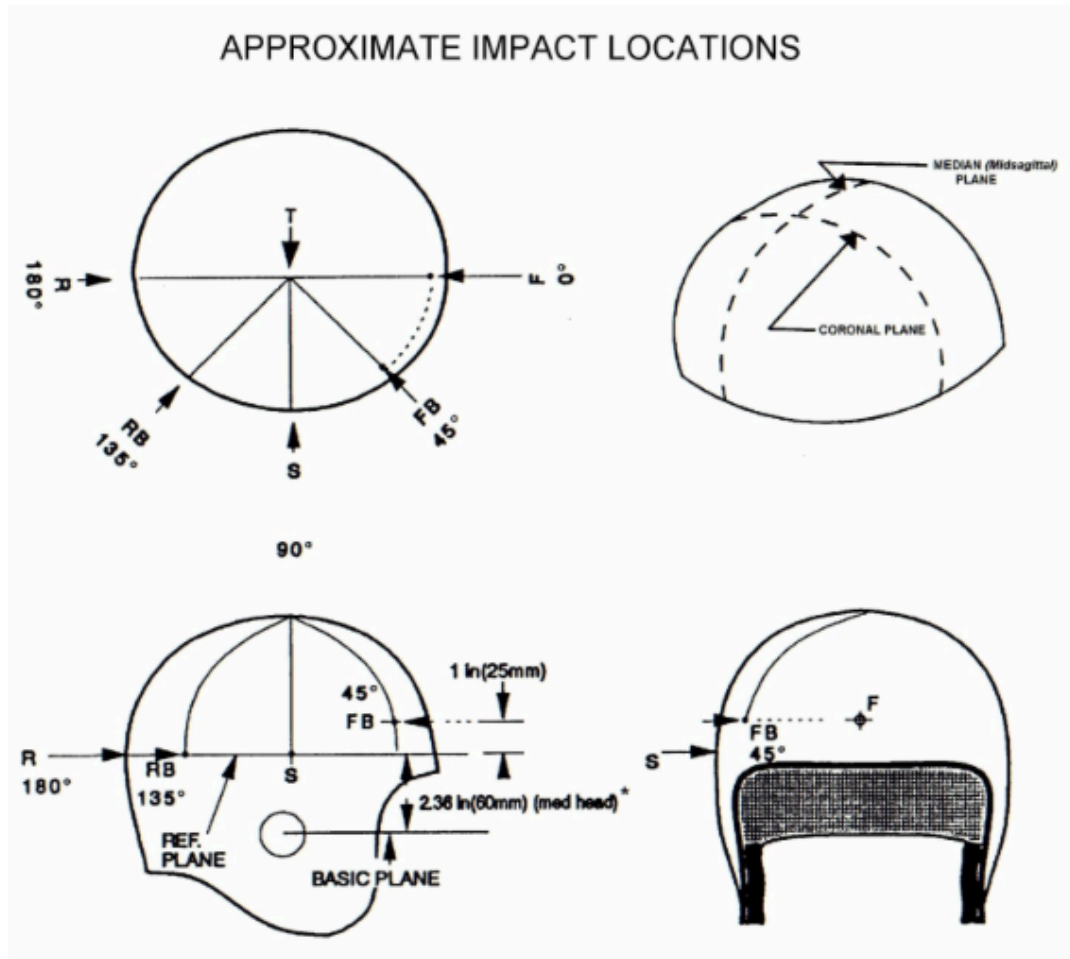

Figure 21 Approximate impact locations used during NOCSAE testing [28]

NOCSAE DOC.021

This method starts with a device sensor calibration similar to that of DOC.001. The Helmets are then fitted to the appropriately sized headform. The headform needs to be adjustable along all three major axis as well as rotational. It is then placed onto a linear bearing table; the total weight of this table is not to exceed 5.7 kg. The appropriate projectile for the equipment being tested is then fired out of a similarly appropriate air cannon apparatus, Figure 22, at the appropriate velocity for the test. The test is repeated until a statistically relevant amount of data points are collected at multiple impact locations described in DOC.001, Figure 21. Upon impact the

acceleration is measured with a tri-axial accelerometer located in the headform, and applied to the SI equation and the passing number is again 1200 index units [29].

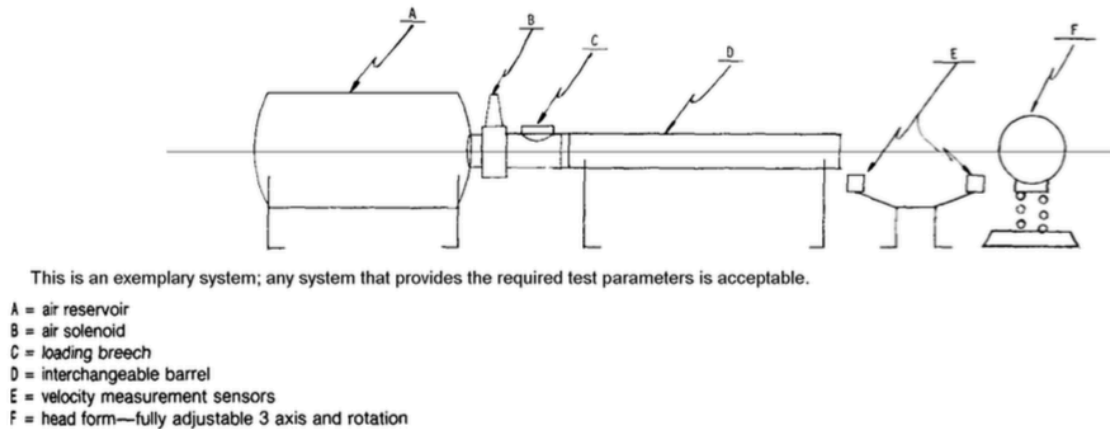

Figure 22 Air cannon requirements for NOCSAE DOC.021 [29]

3.1.3 VT-WFU SBES

The Center for Injury Biomechanics of Virginia Tech and Wake Forest Universities is a program dedicated to understanding and preventing concussions in athletics. The center has conducted many different innovative studies that focus on collecting data from actual in game data, as well as creating better helmet evaluation standards [26] [27].

These studies have been going on for several years at Virginia Tech. The school has partnered with Riddell to create a six-degree of freedom (6-DOF) accelerometer system that fits inside the football helmet. The athlete can wear this 6-DOF device during actual game situations, and collect data from actual football impacts. Before this, the only way to collect such data was to recreate impacts that had video recording from several angles, and recreate the collision using lab dummies, which was labor intensive as well as not totally accurate.

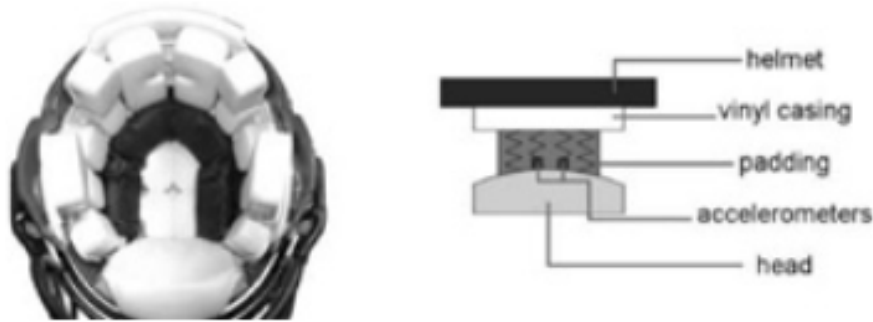

Figure 23 Schematic of a 6-DOF sensor [31]

The 6-DOF sensors have been used for several years now, resulting in data from hundreds of athletes in a variety of positions, with data from hundreds of thousands of impacts that have been carefully documented and correlated with known concussions. As a result there now exist real gameplay data that has been extremely beneficial in understanding how tolerant the human body is and understanding which acceleration thresholds result in injury [30] [31].

From the knowledge gained through the 6-DOF system, VT-WFU SBES has also created a third party testing center that releases a rating system for all available helmets. The Summation of Tests for the Analysis of Risk or STAR rating system was created because there was a lack of public information available for how well football helmets performed. The idea was to produce a list similar to that available for car safety ratings. The test used to collect the data for STAR is a variation of the drop test standards set by NOCSAE. Instead of using the SI as defined by NOCSAE, the STAR system uses its own calculation or STAR number defined as:

$$STAR = \sum_{L=1}^4 \sum_{H=1}^6 E(L,H) \cdot R(a) ; R(a) = \frac{1}{1 + e^{-(\alpha+\beta a)}}$$

This STAR value is the summation of the risk value function $R(a)$, dependent on the measured acceleration values, for 4 different impact locations (front, side, rear, and top) at 6 different drop heights. The location and heights were determined by percentages taken from 51,008 impacts collected from 2006 to 2010 by the 6-DOF system, to best simulate the actual location and severity of impacts a player will receive during gameplay. These STAR numbers are then put on a rating scale and released as a helmet rating lists that ranks each helmet model in accordance to how well it performed on the test [27] [33].

3.2 Auburn Testing

There were two different tests performed during this thesis. The first was a preliminary, impact test that was used to determine if the pursuit in further testing would be propitious. The second, or main, test used in this thesis was the air cannon test. It was developed as a comparison test. For this test, a football helmet that uses current, standard TPU padding is used as a baseline for performance. The results from this helmet were compared as a passing standard to those of helmets modified so that the trauma reducing fabrics are used as padding. The premise is that the helmet with the better performance on the test will be the one with the material that is the better pad.

3.2.1 Impact resistance (impact test)

The impact testing was performed using the Instron Dynatup. This machine has a tup with a semi circular shaped end that is dropped onto the fabric sample to be impacted. The tup is connected to the load cell by a weight of 2.3814 kg.

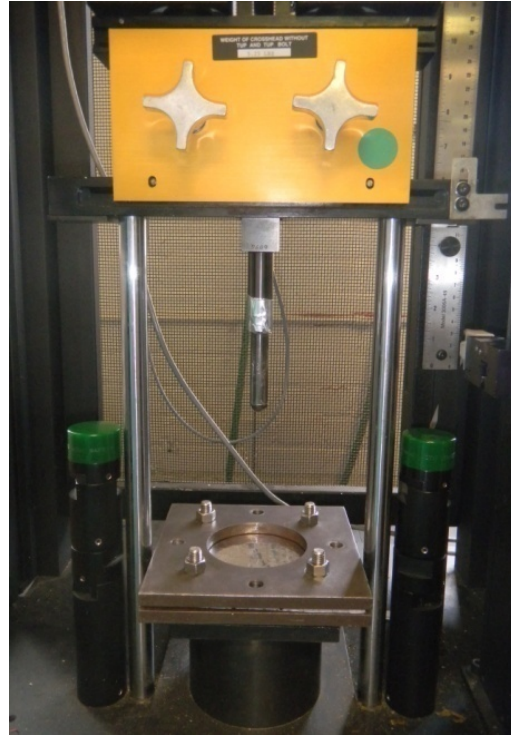

Figure 24 **Instron Dynatup**

The total weight falling down to impact the samples was 2.7258 kg including the tup and tup bolt. It is evident that this test is not similar to an impact that would occur in a football game, which is why this was simply used as a marker to see if the fabric was going to perform as expected. The samples used in this impact resistant test were the old Kevlar trauma reducing nonwoven, two different samples of the new ST trauma reducing fabric, and TPU padding from two different helmet models. As shown in Figure 24 the samples were placed in a frame that prevents rotation of the specimen during impact. The software for this machine gives several different pieces of information, the most important to us being impact energy absorbed by the sample.

3.2.2 Air Cannon Testing

To test the material performance for the padding in the football helmets, the experimental test chamber of the existing air cannon was modified to fit the requirements for our experiment. The experimental set-up allows running tests with projectiles instead of running test samples in drop weight testing machines. This equipment is used to simulate impact-absorbing tests on helmets with a close approximation to real collisions.

Air Cannon Cabinet

The test cabinet houses the headform system, target where the accelerometers are fixed to the headform and helmet. A chronograph is also housed in the cabinet with a data acquisition system that displays the velocity of the projectile. A compressed air cannon launches the projectile towards the target headform. A schematic representation of the experimental set-up is shown in Figure 25, and a 3-D model of the apparatus is shown in Figure 26.

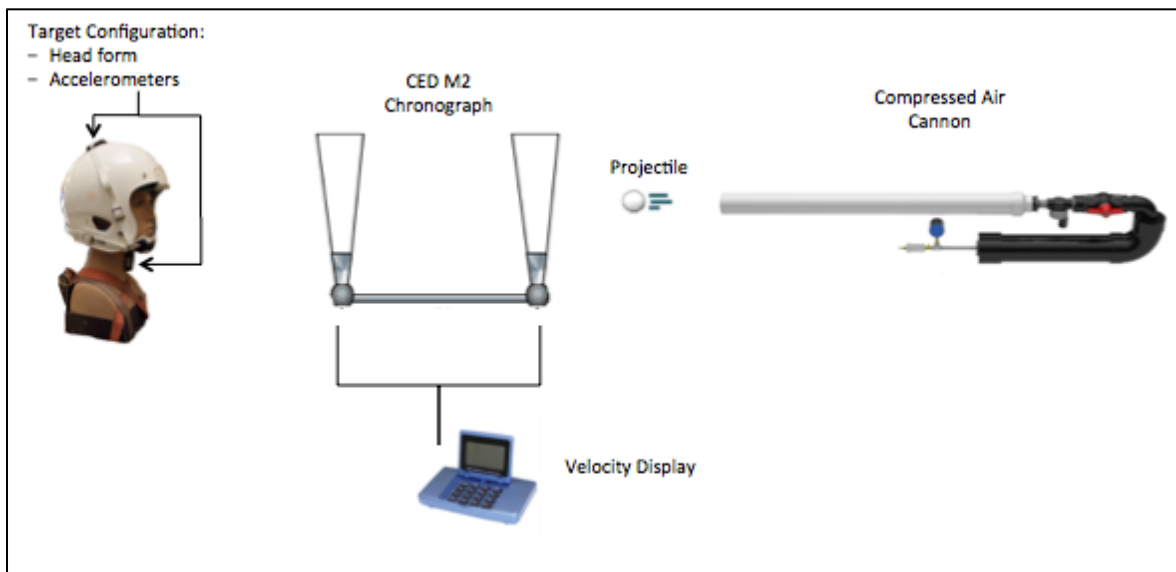

Figure 25 **Experimental scheme set-up**

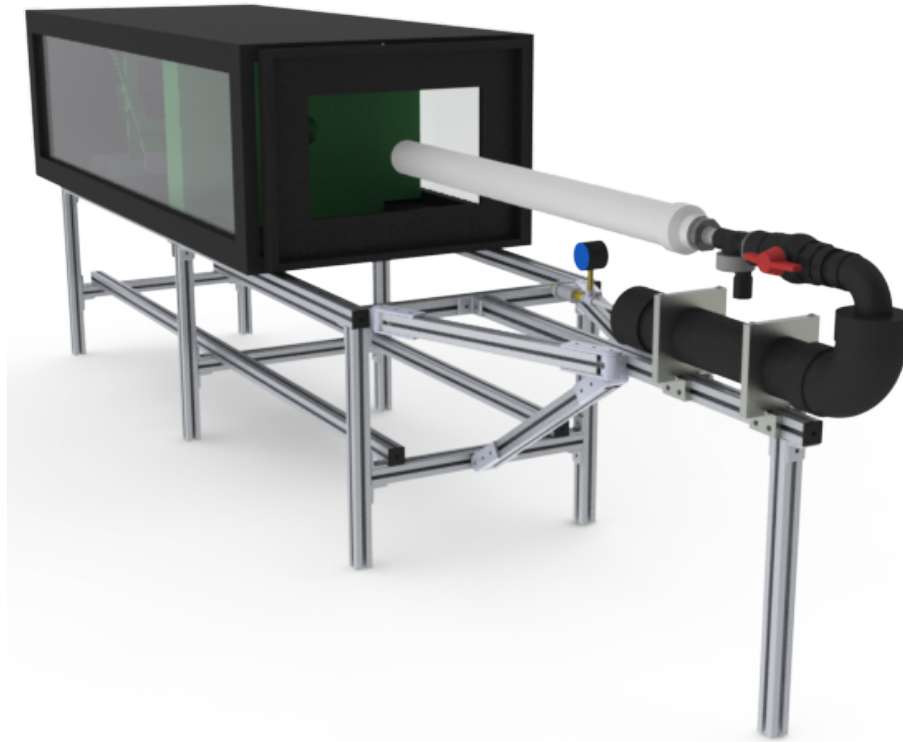

Figure 26 **3-D model of air cannon apparatus [34]**

Compressed Air Cannon

The compressed air cannon (Figure 27) was made with schedule 40 PVC pipe and braid reinforced using a braiding machine. Multiple layers of fiberglass were applied over the reservoir. Polyester resin was applied along with resin transfer molding to infuse fiber to the resin matrix to achieve a higher safety level. An electro-valve is placed in line with the reservoir and barrel for the trigger mechanism; this system uses a solenoid to release pressure through the barrel. The system for aiming incorporates a fixed reservoir locked into place on the frame by locking fixtures (Figure 28), and the barrel is minutely adjustable with a screw-type system to

fine-tune its accuracy. With this compressed air cannon it is only possible to fire a single projectile. [34]

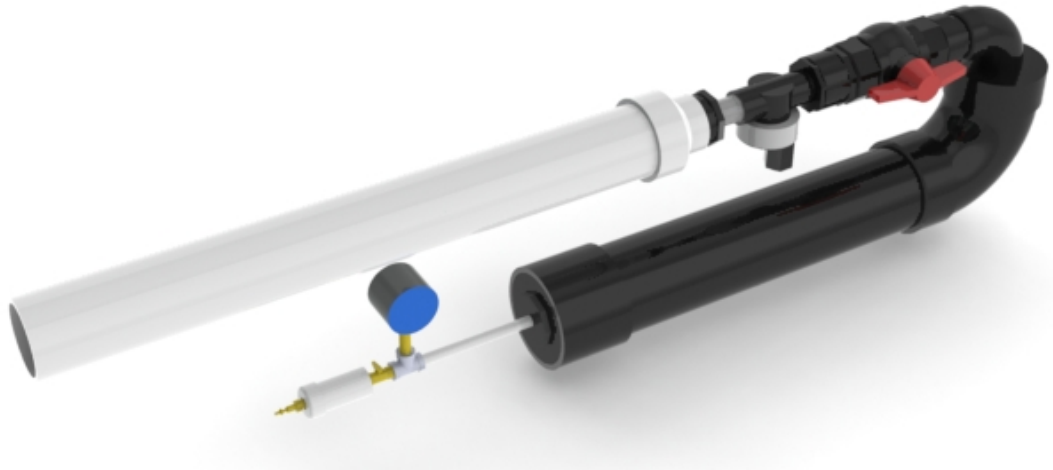

Figure 27 **Compressed air cannon** [34]

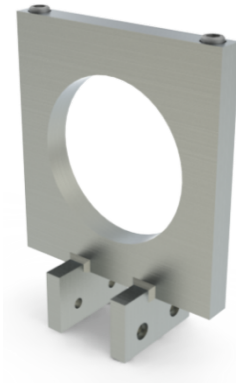

Figure 28 **Reservoir locking fixture** [34]

Test Chamber

A cabinet measuring 2 x 0.84 x 0.58 meters (Figure 30) was redesigned with three sections. The first divide is a two barrier system the first barrier being a safety wall composite assembled of contact film, balsa wood and polystyrene foam and the second a thin piece of foam board. The second divide is a wire barrier placed before the headform to block any rebounded projectiles.

The first sectional area is used to reduce the amount of windblast sent through the cabinet, which could affect the chronograph reading, as well to stop any possible errant shots. The second, sectional area lies between the two barriers, where the chronograph is located, which measures the velocity of the projectile. The third sectional area is where the headform is located. The test chamber shown in Figures 29 and 30 is mounted onto an aluminum frame shown in Figure 31.

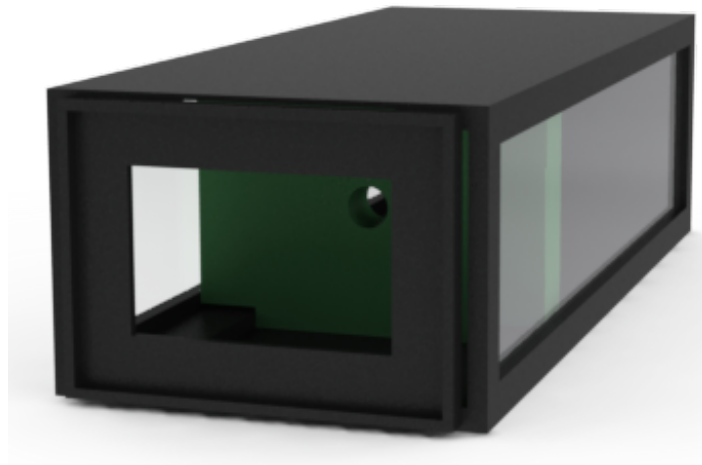

Figure 29 Test chamber [34]



Figure 30 Cabinet sections

The test chamber was redesigned with gas shocks to provide an unattended open position of the doors for the new test set-ups. There are also inspection windows made of Plexiglass that allow quick and easy access during fine-tuning equipment and test specimen replacement. There is also a sliding door to help prevent windblast that may alter recorded velocities; also if there is discrepancy with the path of the projectile in the first section, this will provide ricochet protection. [34]



Figure 31 Air cannon frame [34]

Headform

The headform used in this experiment is a modified mannequin bust. The bust is made out of a plastic shell that is filled with foam inside for support. The headform was modified for support and for mounting into the cabinet. The bust was fitted for a steel base that was folded into a box shape to support the bust and the make the headform mountable. The steel base was then attached to a ½” steel rod that was inserted into the bust to support the neck and head in the impacts. Once the rod was inserted and the steel base was snug on the bust the steel base was

strapped tight to the bust with a ratchet strap to make the headform one piece. The ratchet strap allows the straps to be easily tightened if they were to loosen at all. The bottom of the steel base was fixed to a mounting female thread, that is used to mount the headform to the ½” steel rod that is attached to the frame of the air cannon, Figure 33. The rod that is attached to the frame is movable along all three major axis and can be rotated around the rod’s axis for proper positioning of the headform, Figure 34.



Figure 32 **Headform**



Figure 33 **Headform base**



Figure 34 **Rod attachments to cannon frame**



Figure 35 **Headform attachment to rod**

Data Collection Equipment

The data collection necessary for this experiment comprised three items: weight of projectile, speed of projectile, and acceleration of headform.

The weight of the projectile was measured prior to each shot during the testing. The weight was determined using an Adam LBK6a model scale. This scale has a max weight of 3 kg and precision of 0.5 g.

The projectile's velocity was measured using a CED M2 Chronograph with Infrared screens. The chronograph has a range from 50 fps (15.24 m/s) to 7000 fps (2133.6 m/s), and a precision of 0.1 m/s [35].



Figure 36 CED M2 chronograph

The acceleration of the headform was measured using two tri-axial G-Force Tracker, GFT, accelerometers. The GFT's were mounted onto the headform using the adhesive mounting system provided with the accelerometers. The locations of the GFT's were selected in accordance to the guidelines provided in the user guide, which suggest that the user mount the device on the helmet, as well as a location mounted on the headform according to the test referenced for procedures, such as NOCSAE in which the accelerometers were mounted inside the headform [36][28][31]. The helmet sensor was mounted on the top of the helmet because this was a location where it would not be impacted directly by the projectiles. The sensor mounted on the headform was placed on the front of the neck for access purposes. Sensor locations can be observed in Figure 38.



Figure 37 **Tri-axial G-force Tracker accelerometer**



Figure 38 **G-Force Tracker mounting locations on headform**

Testing Parameters

With the helmet properly fitted to the headform, the G-Force Trackers are both properly calibrated to their respected positions. The headform is then weighed and mounted into the air cannon cabinet, and aligned so that the projectile impacts the desired position by use of a laser pointer mounted on the barrel of the cannon. Once in the proper position the headform is tightened and secured.

After the headform is secured into place, the clay for the projectile is weighed and formed into proper shape. For this experiment, a white natural modeling clay projectile is used. The clay was chosen because it is a dense material that transfers most of the energy of the collision to the headform, and also has minimum rebounding after the collision, which is ideal for the confined

space in the cabinet. The clay projectile is formed into a sphere approximately the size of a baseball, wrapped in a fabric, and placed in a plastic sandwich bag to minimize friction in the barrel and contain the clay after impact with the headform, Figure 40. Once the projectile is formed, it is weighed and that weight is documented prior to every shot, slight decrease in the projectile weight is observed as test sessions carry on.

The following parameters are controlled in the experiment: initial weight of the projectile (435 ± 5 grams), air pressure of cannon before firing (120 ± 2 psi), position of impact on headform (front, side, rear), and padding used in the helmet.

In all except one test session, 30 shots are fired with a cannon pressure of 120 ± 2 psi at the headform, the headform is impacted in the same position for the entire session. For each shot in the session the projectile's weight and velocity are documented and correlated with the resultant acceleration of the headform for that collision. Three different sessions were performed for each location. All three locations are impacted for every padding variation.

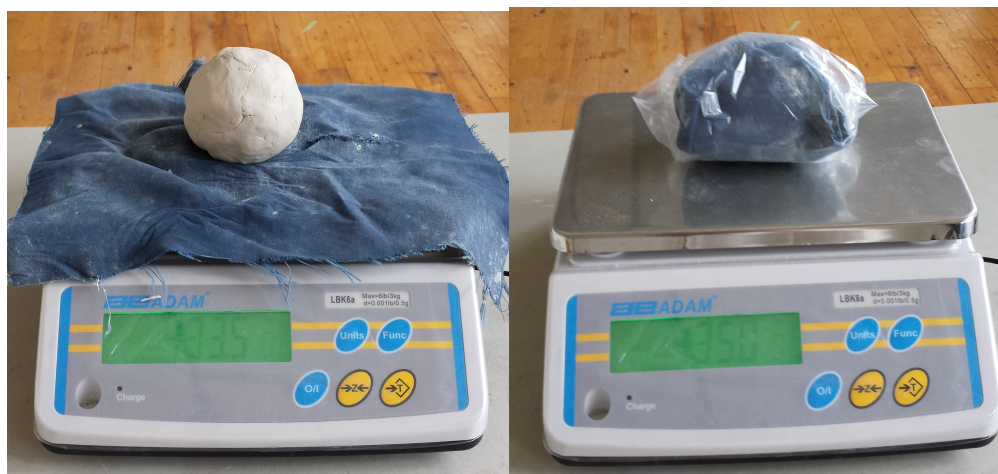

Figure 39 **Clay projectiles (Left: clay projectile molded into sphere, Right: clay projectile wrapped in fabric and plastic bag)**



Figure 40 Impact locations (Left: Rear, Middle: Side, Right: Front)

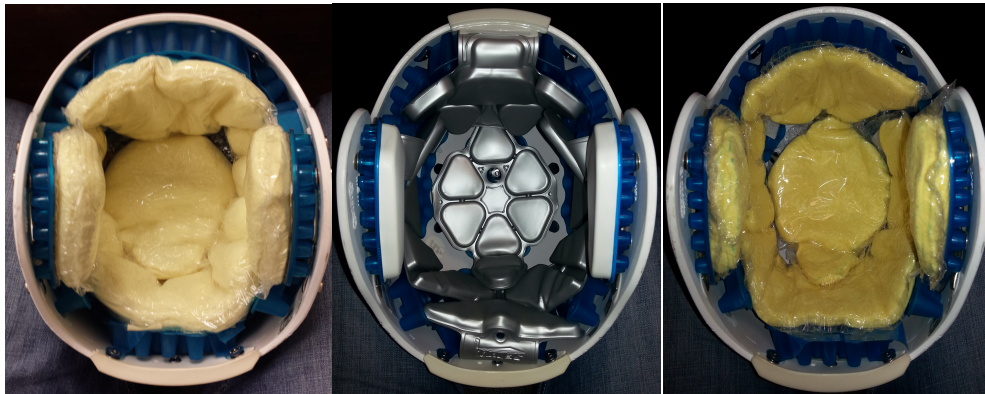

Figure 41 Helmet padding variations (Left: New ST Trauma Reducing Fabric, Center: Schutt Padding, Right: Old Kevlar Trauma Reducing Fabric)

Helmet Padding Variations

This experiment is a comparison test designed to evaluate the protection of different padding materials used in football helmets. To give a fair comparison only one control factor can be changed between compared sessions. The main control that was changed in this experiment was the padding material.

The padding used as the standard is the original helmet padding. This is a TPU foam pad engineered for use in the Schutt Air XP Pro helmet, which is one of the best helmets on the market, according to the 2014 STAR helmet ratings, scoring the second highest rating in the five star category [37]. The helmet that properly fit the headform was a size medium, and the helmet used in testing was donated by the Auburn University Athletic Department, and had been NOCSAE certified for the 2014 football season.

For the other padding variations the TPU foam was removed from the helmet shell and replaced by the samples of trauma reducing fabric. To make the trauma reducing fabric pads, the fabric was cut into shapes matching those of the padding taken out of the Schutt helmet, Figure 43. The shapes were then layered until the desired thickness was obtained for a proper helmet fit. Once the layers were stacked together they were contained into one single pad by wrapping the layers in a plastic heat shrink-wrap, and then shrinking the wrap to fit. The new fabric pads were then mounted in the correct locations of the helmet with double-sided tape.



Figure 42 **Padding shapes (Top: New ST Trauma Reducing Fabric, Middle: Schutt TPU Padding, Bottom: Old Kevlar Trauma Reducing fabric)**

Two fabric types were tested in this thesis: the previous Kevlar® trauma reducing fabric and the new ST trauma reducing fabric. And of these variations a sub variation of the Kevlar® trauma reducing fabric was tested where a layer of special bubble wrap was placed between the fabric pad and blue TPU plastic layer of the helmet to see if a solid layer that increased surface contact area would increase the performance of the fabric.

In total four padding variations were tested with impacts to three locations on the helmet resulting in twelve sets of data to compare:

1. Schutt TPU Padding – Front Impact
2. Schutt TPU Padding – Rear Impact
3. Schutt TPU Padding – Side Impact

4. Old Kevlar Trauma Reducing Fabric Padding – Front Impact
5. Old Kevlar Trauma Reducing Fabric Padding – Rear Impact
6. Old Kevlar Trauma Reducing Fabric Padding – Side Impact
7. Old Kevlar Trauma Reducing Fabric Padding w/ Bubble Wrap – Front Impact
8. Old Kevlar Trauma Reducing Fabric Padding w/ Bubble Wrap – Rear Impact
9. Old Kevlar Trauma Reducing Fabric Padding w/ Bubble Wrap – Side Impact
10. New ST Trauma Reducing Fabric Padding – Front Impact
11. New ST Trauma Reducing Fabric Padding – Rear Impact
12. New ST Trauma Reducing Fabric Padding – Side Impact

4. EXPERIMENTAL RESULTS

4.1 Impact Resistance (impact test)

The impact resistance test was performed early in the development of this thesis as a quick test to determine if the manufacturing modifications were giving results that competed with the old fabric as well as if the fabrics would compete on par with the foam padding used in the football helmets.

Table 2 and Figure 43 show the results of impact energy absorbed from the preliminary fabric comparison testing performed on the impact machine. The value for energy absorbed in the test was divided by the density of the fabric samples tested to get the material efficiency.

Table 2 Preliminary fabric comparison

Material Tested	Material Density (Kg/m ³)	Energy Absorbed in Test (Joules)	Material Efficiency (Joules/Gram x10 ⁻⁴)
Old Kevlar Trauma Reducing Fabric (2-layers)	36.61	6.16	1.683
Old Kevlar Trauma Reducing Fabric (3-layers)	39.54	15.97	4.039
First Sample New ST Trauma Reducing Fabric (2-layers)	50.46	1.54	0.305
First Sample New ST Trauma Reducing Fabric (3-layers)	55.91	3.54	0.633
Second Sample New ST Trauma Reducing Fabric (1-layer)	57.64	6.19	1.074
Second Sample New ST Trauma Reducing Fabric (2-layers)	55.86	13.36	2.392

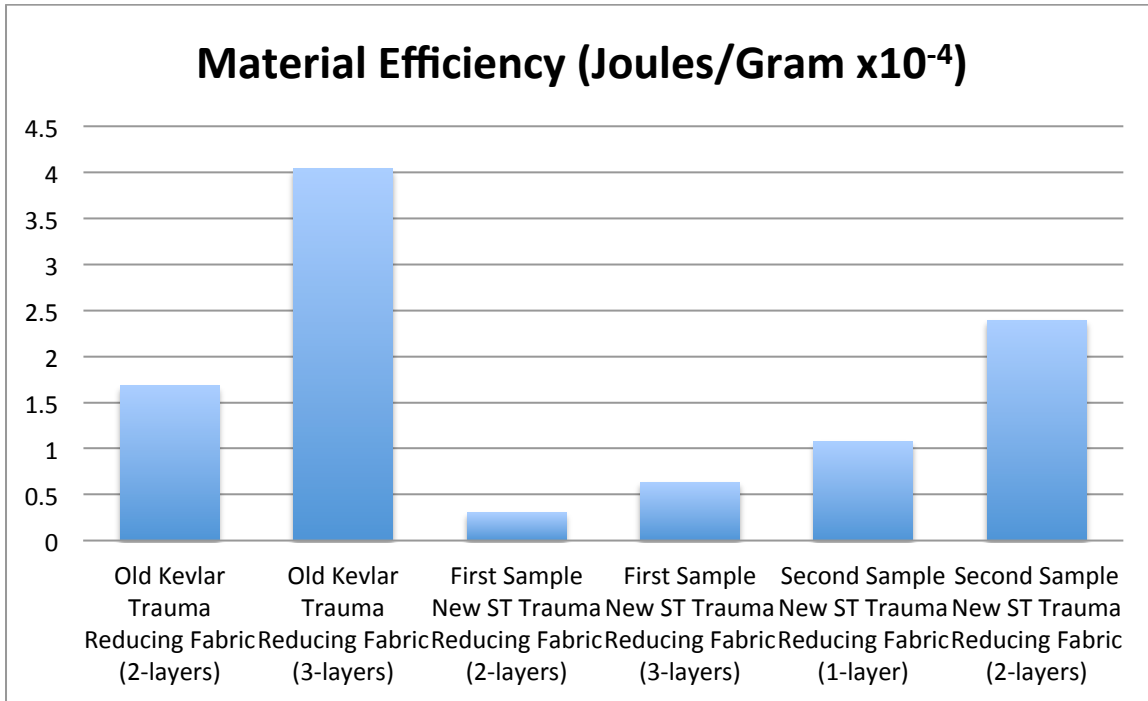

Figure 43 Plot for material efficiency for preliminary fabric comparison

From these results one can notice that the second sample performed significantly better than the first sample of the new fabric. Also the second sample performs better than the old Kevlar trauma reducing fabric.

The results from the preliminary fabric comparison were so promising that the test was slightly modified, by adding a cardboard layer to the test, and the second sample was compared to padding that was removed from two different football helmets. The foam pad came from a Schutt Air XP Pro and a Riddell Revolution Speed Classic. The cardboard was added to the test to provide a layer for the pads to rest on in the machine. Since the fabric and both pads were different shapes and sizes the numbers for energy absorbed was again divided by the material

density to get a material efficiency number to compare, data can be seen in Table 3 and Figure 44.

Table 3 Fabric comparisons to football helmet paddings

Material Tested	Material Density (Kg/m ³)	Energy Absorbed in Test (Joules)	Material Efficiency (Joules/Gram x10 ⁻⁴)
Second Sample New ST Trauma Reducing Fabric (1-layers)	57.64	8.69	1.508
Second Sample New ST Trauma Reducing Fabric (2-layers)	55.86	10.81	1.935
Schutt TPU Pad	275.86	19.07	0.691
Riddell TPU Pad	183.44	16.96	0.925

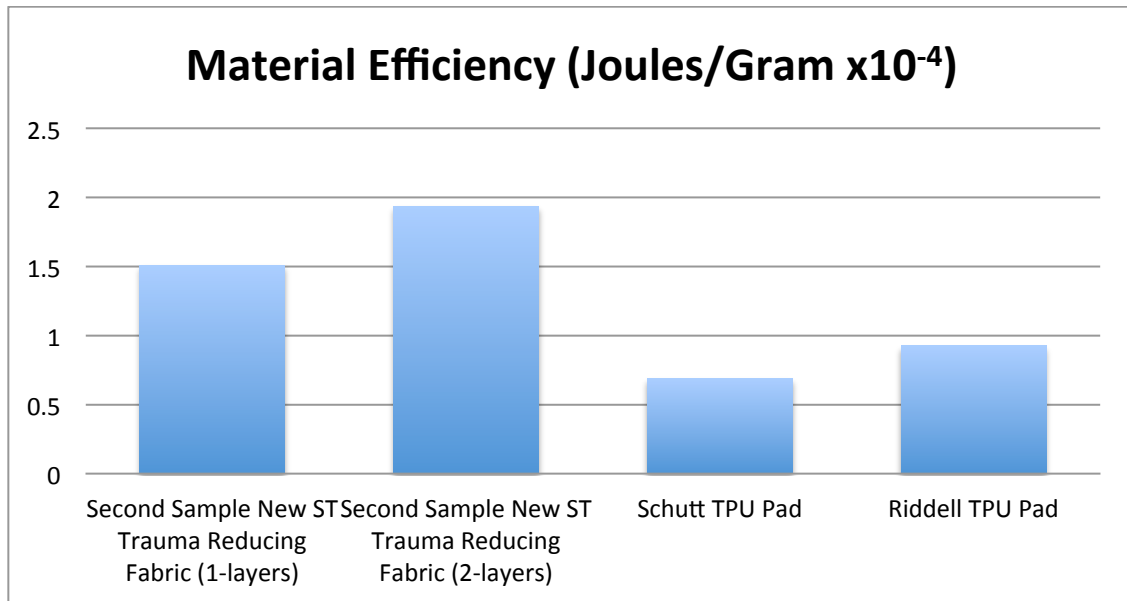

Figure 44 Plot for fabric comparisons to football helmet paddings

The data from the fabric comparison to the football helmet padding shows that for the test performed that the fabric has a better material efficiency than both foam pads. These results seem

to support the hypothesis that the trauma reducing nonwoven will perform very well as a football helmet pad, and shows great promise going into the next set of tests.

4.2 Air Cannon Testing

The results of the air cannon test was the determining factor in how well the trauma reducing nonwovens will perform in a football helmet pad. To analyze these results we needed to focus on two things: which GFT has the most accurate data, and what that data tells us.

4.2.1 GFT Data Accuracy

In Figure 45 and 46, plots for the measured G-Force values correlated with the kinetic energy of their respective projectiles are displayed.

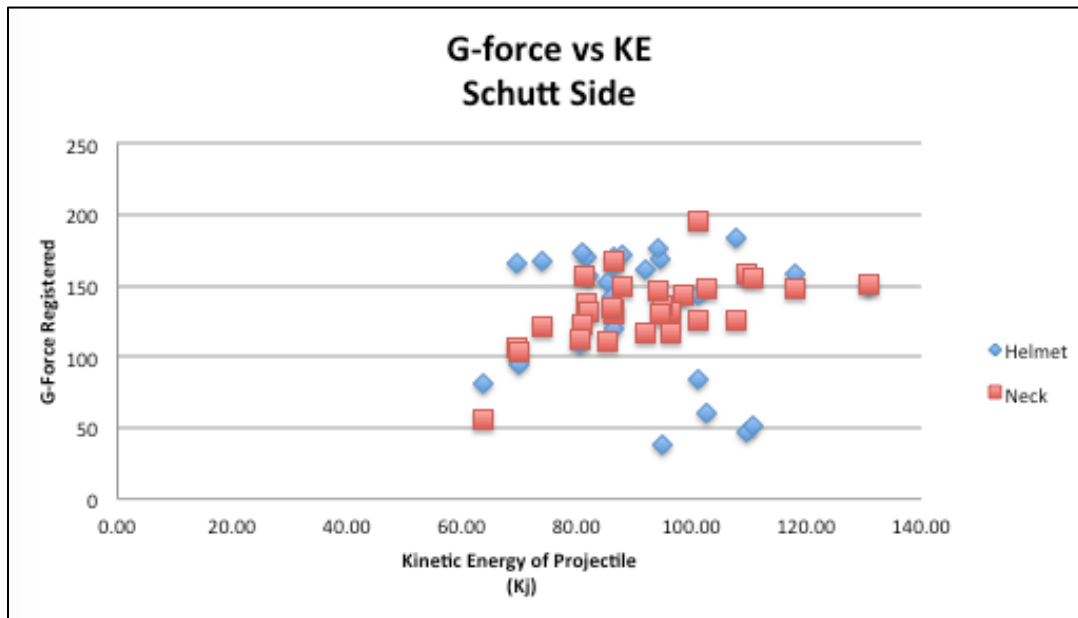

Figure 45 Plot showing similar data between the neck and helmet sensors for side impact

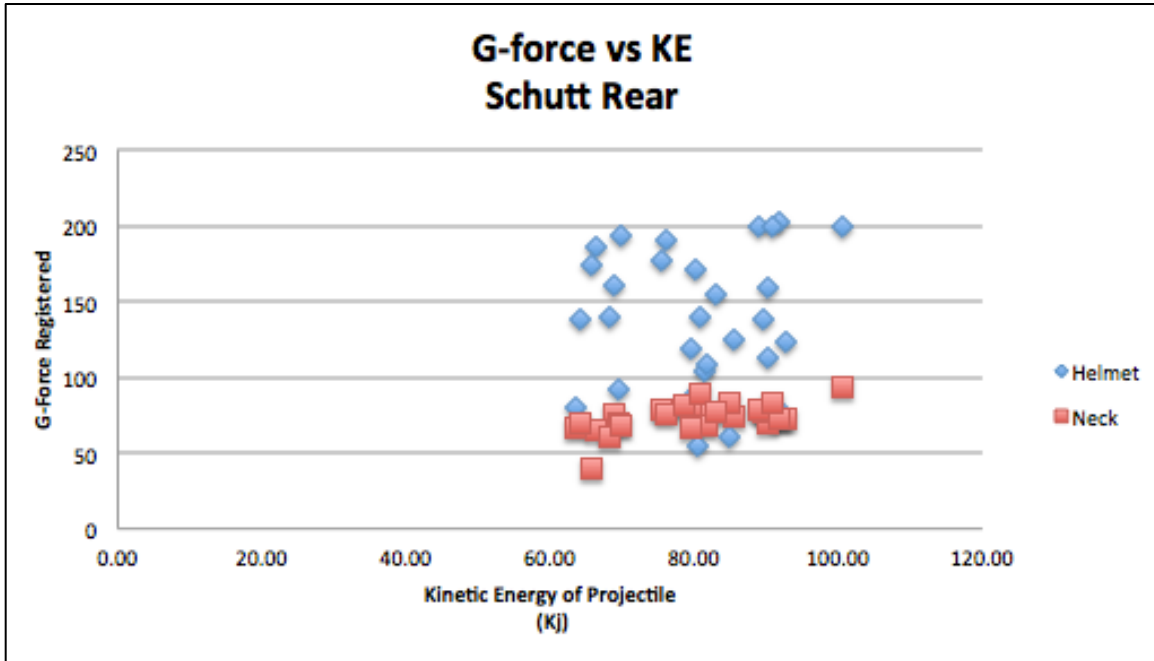

Figure 46 Plot showing differences in intensity and grouping for helmet and neck sensors

The plot in Figure 46 shows a clear difference between the G-force values of the helmet sensor, represented by the blue data set, and the neck sensor, represented by the red data set for impacts in the rear location, this trend was also observed for front impacts for all four pad variations as well, reference appendix for additional plots. However, the side impact location shows very similar data for both sensors (Figure 45). This is a very interesting occurrence. A likely explanation for this goes back to a simple concept that is used in protective materials, surface geometry. The curvature of the helmet is more severe on the front and rear, but the helmet flattens out on the side. This decrease in curvature would likely lead to an increase in transferred collision energy at that position, which is why the neck sensor reads higher G-forces at that impact location [38].

But if one looks at the data as a whole the sensors mounted on the neck of the headform have much tighter groupings than the helmet mounted sensors, as further indicated by the standard deviation values listed in Table 4.

Table 4 Standard deviations of G-force for both sensor locations

Impact location	Pad	G-force Standard Deviation	
		Helmet Sensor	Neck Sensor
Side	Schutt	42.13758182	24.08939795
	Old	24.52933754	28.31867758
	Old Bubble	28.39443356	25.65072788
	New	22.44626357	22.76251307
Rear	Schutt	44.794177	9.400293937
	Old	48.45660807	16.89543459
	Old Bubble	39.05278812	30.21107725
	New	53.39734099	35.9354001
Front	Schutt	22.44508995	13.24111569
	Old	31.26805319	14.76543276
	Old Bubble	7.37603863	15.94652967
	New	34.80117493	15.58691411
Average Standard Deviation:		33.25824062	21.06695955

The higher standard deviation shows a greater error in the data gathered by the helmet sensor. This supports the doubts expressed in several different publications that helmet mounted sensors do not give proper head acceleration data, and that the closer the sensor is mounted to the head the more accurate the number collected is to what the brain actually experiences [29][26]. With this idea in mind and the fact that for other lab experiment such as NOCSAE testing the accelerometer is mounted inside the headform, the data from the neck mounted accelerometer is used for all further padding material comparisons.

4.2.1 Padding Material Comparison

The gathered accelerometer data from the projectile test need to be handled in a similar manner to the data from the impact resistance testing. The data from each location is gathered and then the acceleration values need to be normalized by the weight of the padding used in the helmet. The G-force values were normalized to the acceleration experienced if each helmet had 211 grams of padding in it, which is the mass of the Schutt foam padding. That number was then modified to give the amount of G-force per 100 grams of padding, and these values are shown in Table 5. As one evaluates the numbers for G-force that the headform experienced in the collision, a smaller value is a better result.

Table 5 Padding material comparisons

Impact location	Pad	Pad Weight (grams)	G-force	Normalized G-force (per 211 g of pad)	Normalized G-force (per 100 g of pad)
Side	Schutt	211	133.389	133.389	63.218
	Old	127.5	185.066	111.829	52.999
	Old Bubble	136	171.873	110.781	52.503
	New	123	193.403	112.742	53.432
Rear	Schutt	211	73.763	73.763	34.959
	Old	127.5	95.060	57.441	27.223
	Old Bubble	136	106.438	68.605	32.514
	New	123	128.682	75.014	35.551
Front	Schutt	211	75.394	75.394	35.732
	Old	127.5	82.052	49.581	23.498
	Old Bubble	136	78.012	50.283	23.831
	New	123	79.176	46.155	21.874

The experimental results show that the helmet with the Schutt padding performed better outright from the test. However, when the numbers are normalized by the weight of the padding, the trauma reducing fabrics seem to have slightly better numbers than the Schutt TPU foam padding. Figures 47- 50 show these results.

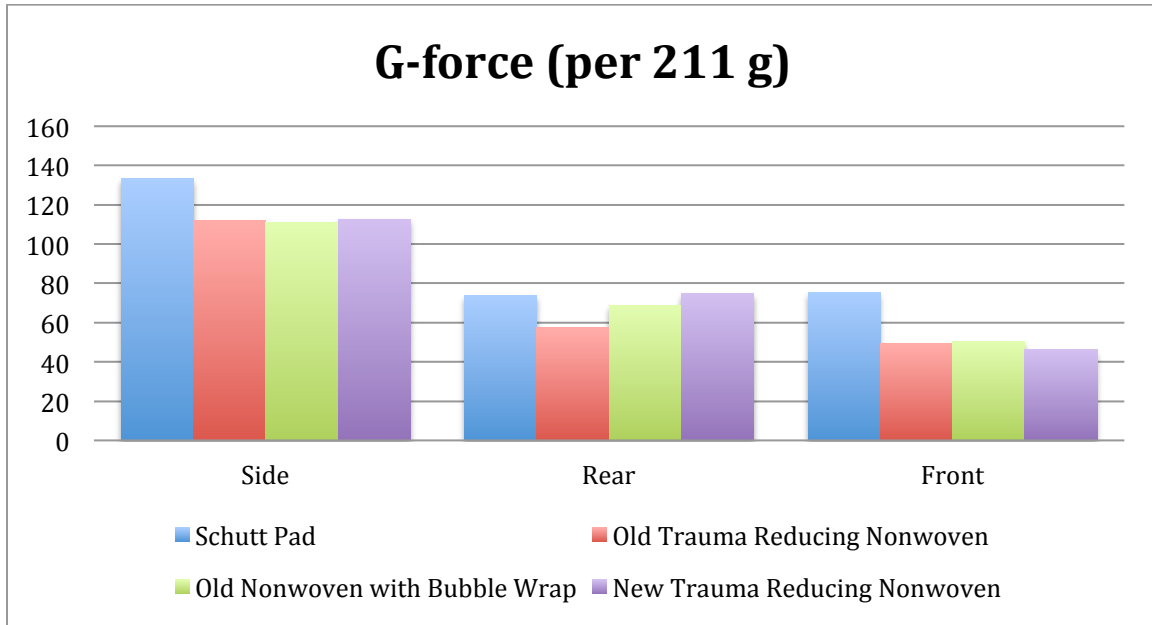

Figure 47 Plot of normalized G-force per 211 g of padding

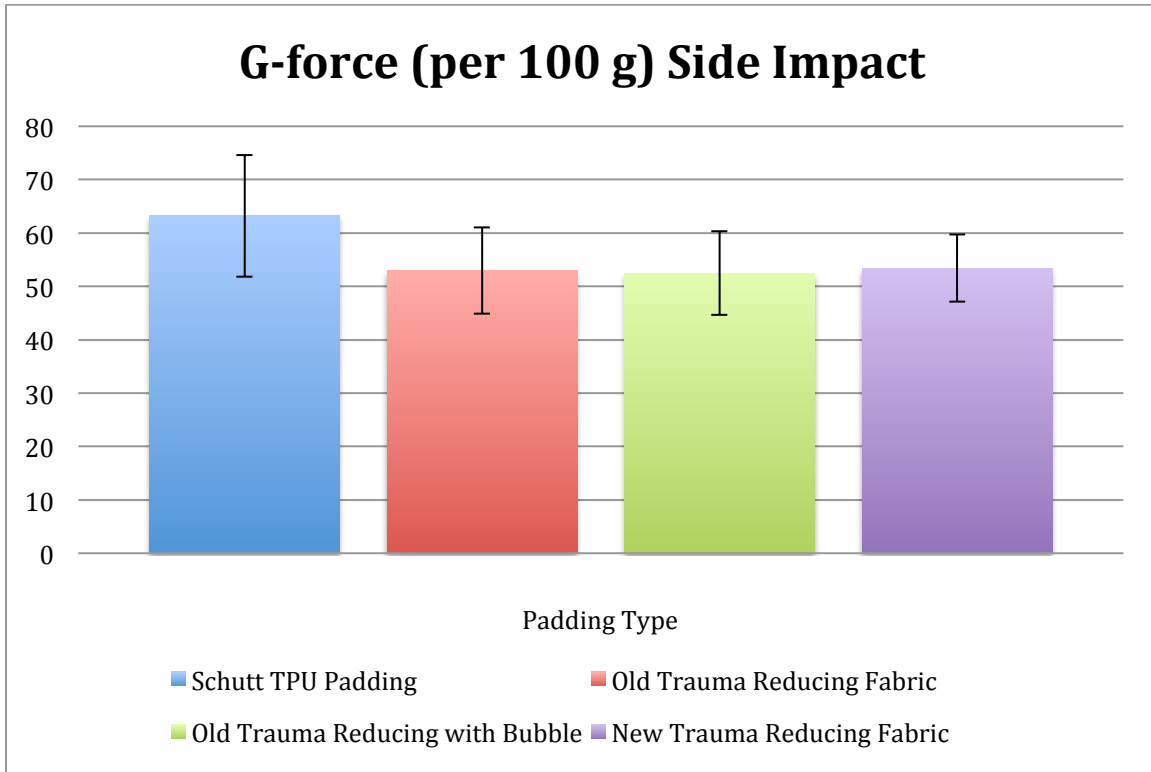

Figure 48 Plot of normalized G-force per 100 g of padding side impact

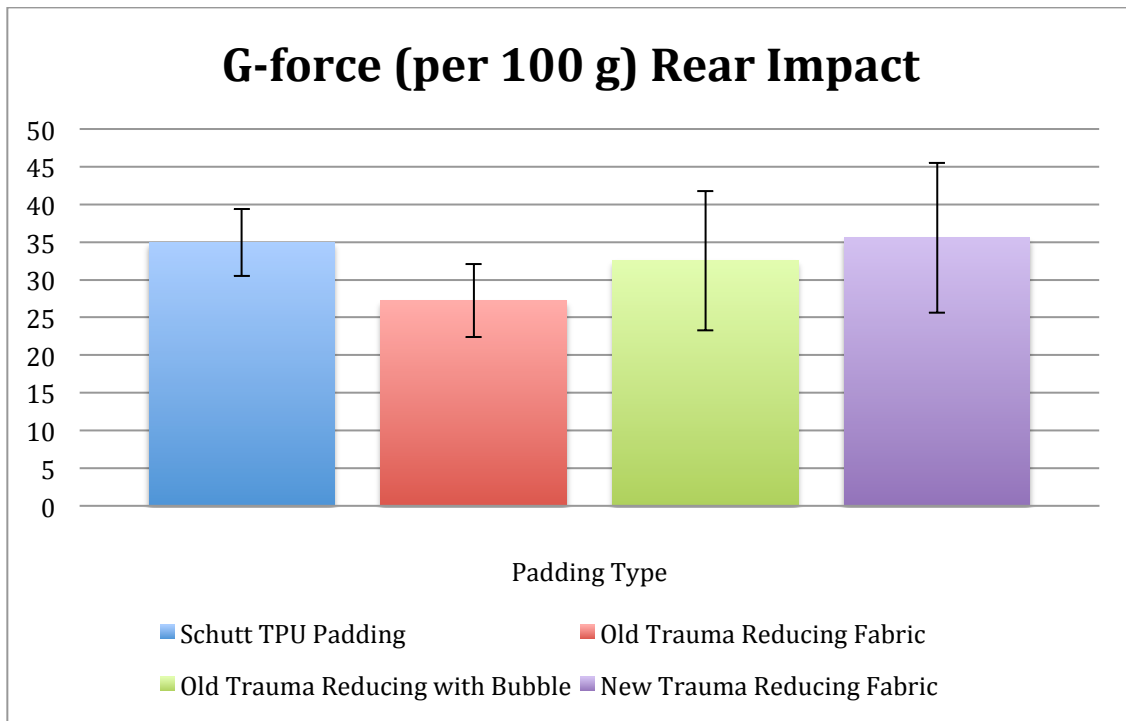

Figure 49 Plot of normalized G-force per 100 g of padding rear impact

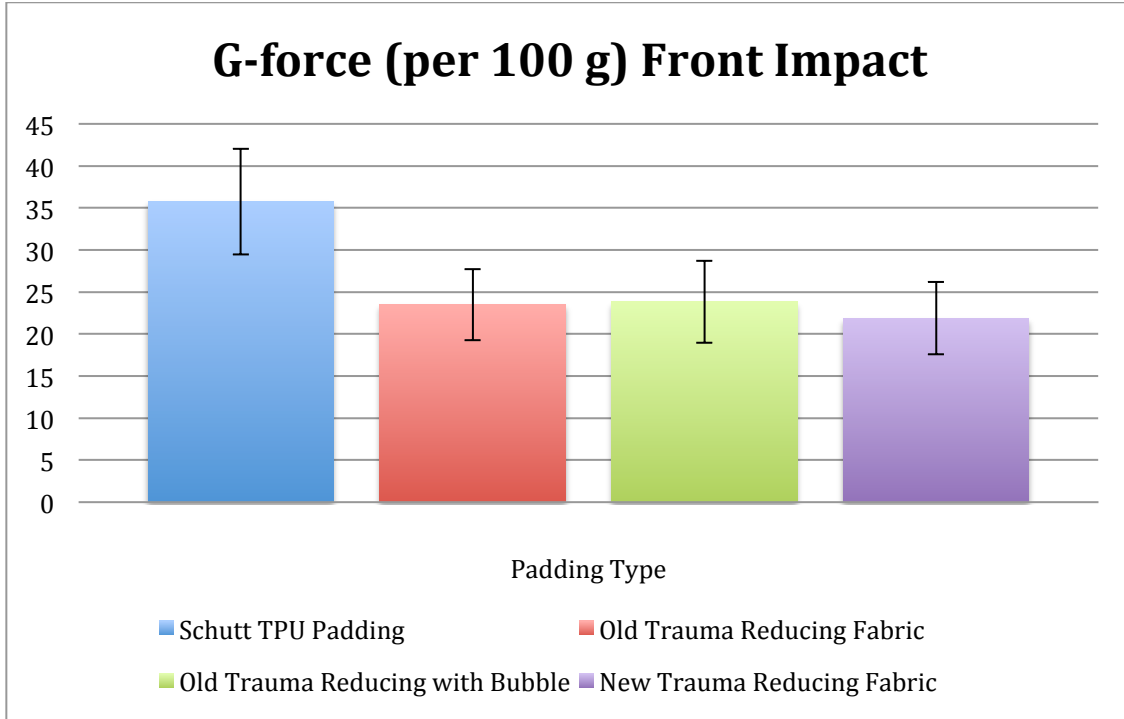

Figure 50 Plot of normalized G-force per 100 g of padding front impact

5. CONCLUSIONS

The original scope of this project was to create a new version of a trauma reducing fabric that is easier to manufacture and yielded equivalent or better properties to the original, and to apply the trauma reducing fabrics into a padding system to be used in football helmets.

The new trauma reducing fabric was successfully created by removing the carding and cross lapping steps from the manufacturing process as described in Section 2. The new and old trauma reducing fabrics were then made into helmet padding systems, and compared to the padding system of the “second best” helmet on the market, by the experiment described in section 3 [37].

The results from the comparison testing presented in section 4 show that when the padding is made to fit the headform that the standard padding system performs better, but when the data was standardized to the weights of the padding used in the helmets the trauma reducing fabrics performed slightly better than the standard helmet system. The new trauma reducing fabric’s performance was almost identical to that of the old trauma reducing fabric.

The conclusions that can be drawn from these results show that a fabric with the same qualities could be successfully reproduced with an easier manufacturing method. The results from the padding comparison are somewhat inconclusive. When the padding is fit into a limited space the raw data is in favor of the standard padding, but when the numbers are standardized by weight of the pad the trauma reducing fabric’s performance was better. From this we can

conclude that the trauma reducing fabric is a material that is worth investigating further for an athletic padding system.

6. RECOMMENDATIONS FOR FUTURE WORK

Additional work is required to develop a padding system that uses trauma-reducing nonwovens as the main material. Suggested systems would involve: The ability to fit more fabric into the helmet shell to create a larger fabric pad, combining several different materials into a pad with layers of this composite pad being the trauma reducing fabric, and several other pad variations.

Also modifications to the testing apparatus could greatly improve the quality of the data that is received in testing, and allow more observations to be made about the padding used. A new headform that better simulates the human head/neck system would provide more realistic data. Accelerometers that could be mounted internally in the headform opposed to on the helmet and neck would also give more realistic data. Also a velocity recording system so that the projectiles rebound velocity could be measured, and more precise data collection systems could allow for numbers to be produced such as acceleration absorbed by a padding system opposed to simply comparing the accelerations the headform experienced in the collision. Changes of this nature to the testing apparatus would greatly increase the understanding of how each padding variation is able to perform.

REFERENCES

1. Medical Dictionary : Concussion. *Merriam Webster Dictionary*. <http://www.merriam-webster.com/medical/concussion>.
2. SYSA Concussion Information Page. *Sadburry Youth Soccer*. December 1, 2013. <http://www.sudburrysoccer.org/sites/default/files/images/concussion.jpg>.
3. Concussion. Mayo Clinic. April 2, 2014. <http://www.mayoclinic.org/diseases-conditions/concussion/basics/symptoms/con-20019272>
4. Guskiewicz, K.M., *Association Between Recurrent Concussion And Late-Life Cognitive Impairment In Retired Professional Football Players*. *Neurosurgery*, 2005. **57**: p. 719-726.
5. Stamm, J.M., *Age of first exposure to football and later-life cognitive impairment in former NFL players*. *Neurology*, 2015. **84**: p. 1-7.
6. Making History Since 1929. *Riddell*. November 27, 2013. <http://www.riddell.com/history>.
7. Stephen Matthew Prongay. (September 21, 2012). The Football Helmet of the Future. *SiOWfa12: Science in Our World: Certainty and Controversy*. November 26, 2013. <http://www.personal.psu.edu/afr3/blogs/siowfa12/2012/09/the-football-helmet-of-the-future.html>.
8. Schutt Air XP. *Schutt*. <http://www.schuttsports.com/asp/Sport/ProductCatalog.aspx?id=792>
9. James Sterngold. (December 9, 2010). Gladiator Helmet Seeks to Eliminate Concussion Pain From Football Players. *Bloomberg*. October 3, 2013.

- <http://www.bloomberg.com/news/2010-12-09/gladiator-helmet-seeks-to-eliminate-concussion-pain-from-football-players.html>.
10. Tyler Riesenger. (January 14, 2011). Behold The Football Helmets Of The Future (Photos). *Sports Grid*. October 3, 2013. <http://www.sportsgrid.com/nfl/bulwark-football-helmets-photos/#2>.
 11. Riddell Speedflex Helmet. *Riddell*. <http://www.riddell.com/riddell-speedflex-helmet.html>.
 12. Xenith Epic Varsity Football Helmet. *Xenith*. <http://www.xenith.com/products/football-helmets/epic-varsity-football-helmet/>
 13. Bullet-proof garments and body armor; plurality of in-plane fibers defining a fabric plane and a plurality of upright ballistic fibers perpendicular to fabric plane
US 6846545 B2. *Google Patents*. January 25, 2005.
<https://www.google.com/patents/US6846545>
 14. AP. (Thursday, June 23, 2005). Warning: Body armor may be defective. CNN. December 1, 2013. http://www.cnn.com/2005/US/06/22/body.armor.defects/index.html?_s=PM:US.
 15. Enno Klop. (November 23, 2011). Materials by design: High Performance Polymers. *Teijin*. November 12, 2013. https://www.kiviniria.net/media/Techniekpromotie/Thema_sKIVINIRIA/Slim_Materiaalgebruik/presentaties/W203_Enno_klop.pdf.
 16. High Strength High Modulus Fibers. *Gertrude*. November 28, 2013. <http://gertrude-old.case.edu/276/materials/21.htm>.

17. Thomas, G.A. Non-woven Ballistic Composites. *Non-woven Fabrics for Military Applications*. February 13, 2008. pg. 17-49.
18. Para-aramids. *Society of Plastics Engineers: Texas A&M University*.
<http://plastics.tamu.edu/taxonomy/term/460>.
19. Material Properties Guide. *IDEX*. <https://www.idex-hs.com/education-and-tools/educational-materials/materials-guide>
20. Air Laid Web Formation. *Textile Learner*.
<http://textilelearner.blogspot.com/2013/07/airlaid-web-formation-technique.html>
21. Dahiya Atul. Dry Laid Nonwovens. April 2004.
<http://www.engr.utk.edu/mse/Textiles/Dry%20Laid%20Nonwovens.htm>
22. Needle Punched Nonwoven Innovations. *Delaware Valley Cooperation*.
<http://www.dvc500.com/needle-punched-fabrics.html>.
23. Laible, R.C. Methods and Phenomena 5, Ballistic Materials and Penetration Mechanics. Elsevier Scientific Publishing Company, Inc. Amsterdam. 1980.
24. Hearle, J.W.S., Purdy, A.T. "Report on Energy Absorption By Nonwoven Fabrics". Contract No. DAJA37-1-C-0554. European Research Office, United States Army, London. November 1971.
25. History and Purpose. *NOCSAE*. <http://nocsae.org/about-nocsae/history-and-purpose/>
26. Duma Stefan M., Rowson Steven. Every Newton Hertz: A Macro to Micro Approach to Investigating Brain Injury. Engineering in Medicine and Biology Society, 2009.
27. Football Helmet Ratings. *Virginia Tech 5-Star Helmet Ratings*.
<http://www.sbes.vt.edu/helmet.php>.

28. *Standard Test Method And Equipment Used In Evaluating The Performance Characteristics of Protective Headgear/Equipment* NOCSAE DOC.001. July 2013.
http://nocsae.org/wp-content/files_mf/1374154133ND00111m13DropImpactTestMethod.pdf.
29. *Standard Projectile Impact Test Method and Equipment Used In Evaluating the Performance Characteristics of Protective Headgear Faceguards or Projectiles* NOCSAE DOC.021. June 2012. <http://nocsae.org/wp-content/uploads/2013/07/ND021-12m13-Projectile-Impact-Test-Method.pdf>.
30. Rowson, Steven. *Journal of Biomechanical Engineering*. Linear and Angular Head Acceleration Measurements in Collegiate Football. June 2009. Vol 131. Pg. 1-7.
31. Rowson, Steven. *Journal of Applied Biomechanics*. A Six Degree of Freedom Head Acceleration Measurement Device for Use in Football. 2011, Vol 27, Pg. 8-14.
32. About Biomedical Engineering. *Virginia Tech / Wake Forrest School of Biomedical Engineering*. <http://www.sbes.vt.edu/welcome/aboutBioMed.php>
33. Rowson, Steven. Development of the STAR Evaluation System for Football Helmets: Integrating Player Head Impact Exposure and Risk of Concussion. *Annals of Biomedical Engineering*, Vol. 39, No. 8, August 2011 pp. 2130–2140.
34. Quinones Silva, Vladimir. *Design of Protective Covers Against Natural Hazards*. May 9, 2011.
35. The CED M2 Chronograph Instruction Manual
36. G-Force Tracker User's Guide
37. Football Helmet Ratings. *Virginia Tech 5-Star Helmet Ratings*.
<http://www.sbes.vt.edu/helmet.php>.

38. P. Halldin , A. Gilchrist. A new oblique impact test for motorcycle helmets. *N.J. Mills International Journal of Crashworthiness* Vol. 6 (1), 2001.

APPENDICES

Appendix A. G-Force values correlated with the kinetic energy of their respective projectiles for all 12 test sessions

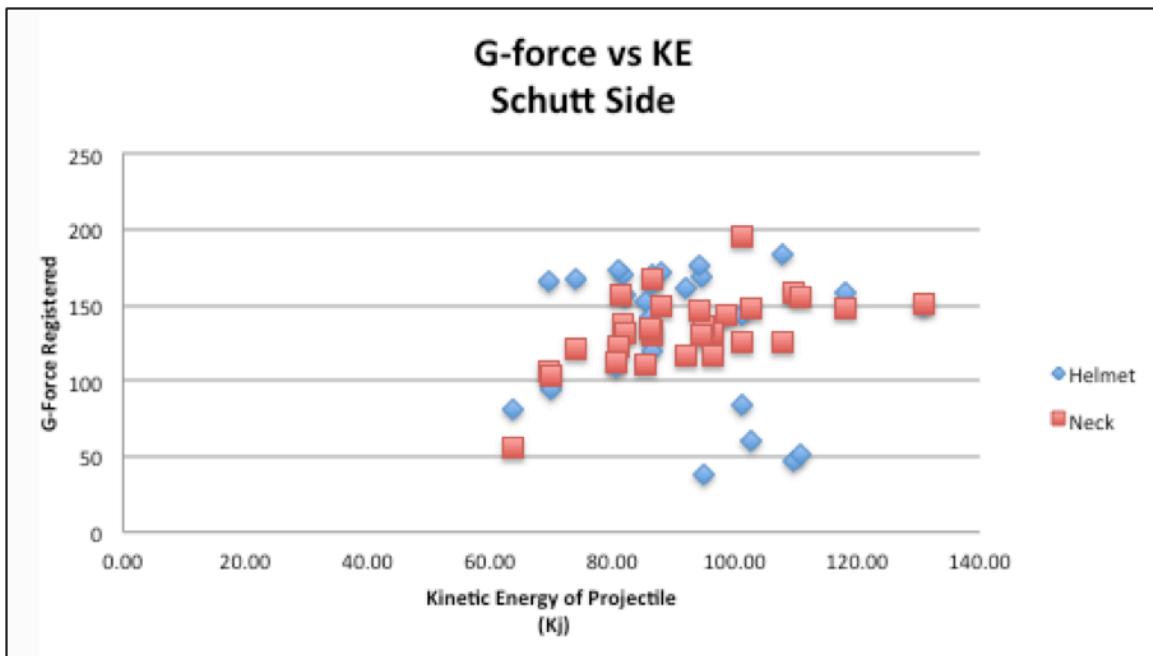
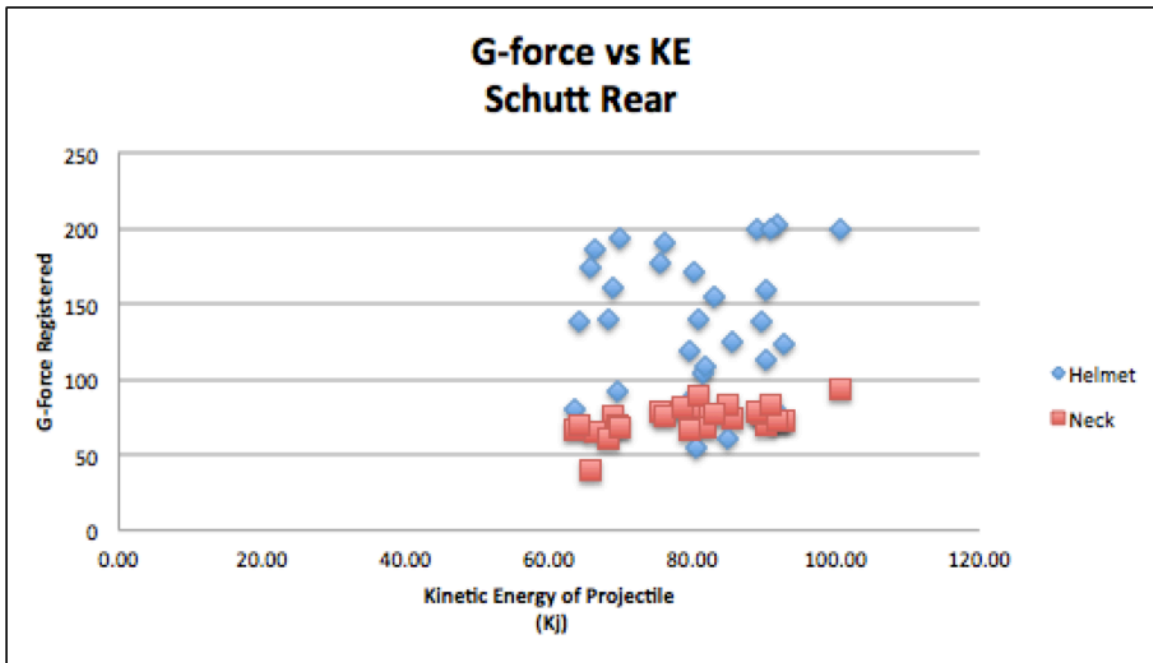

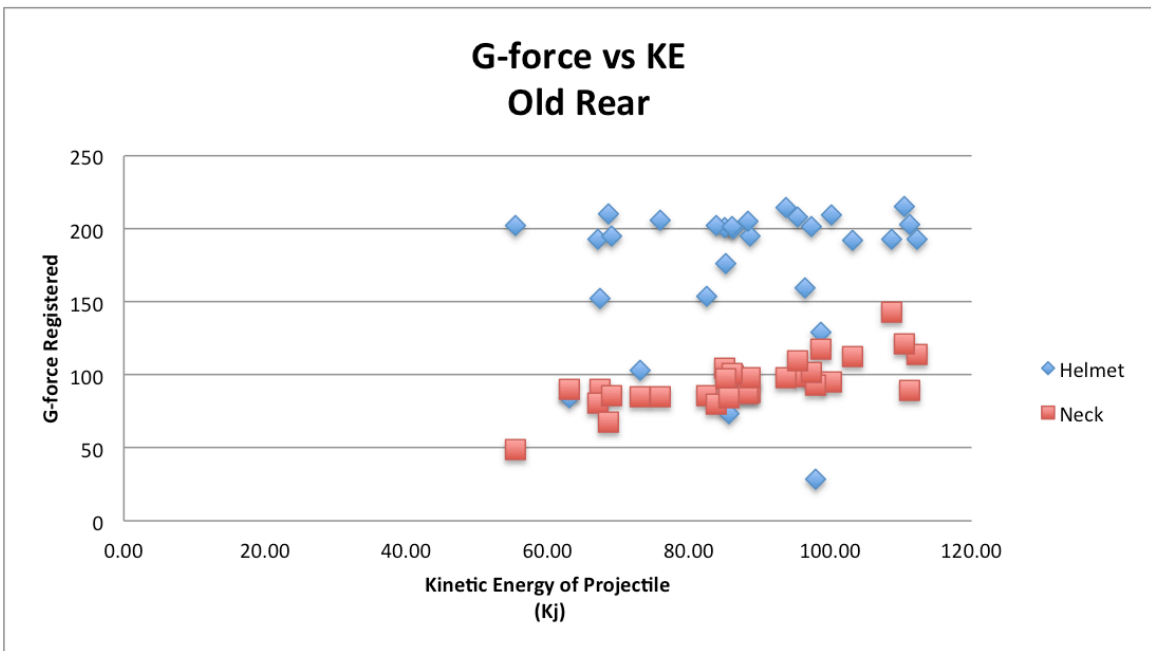
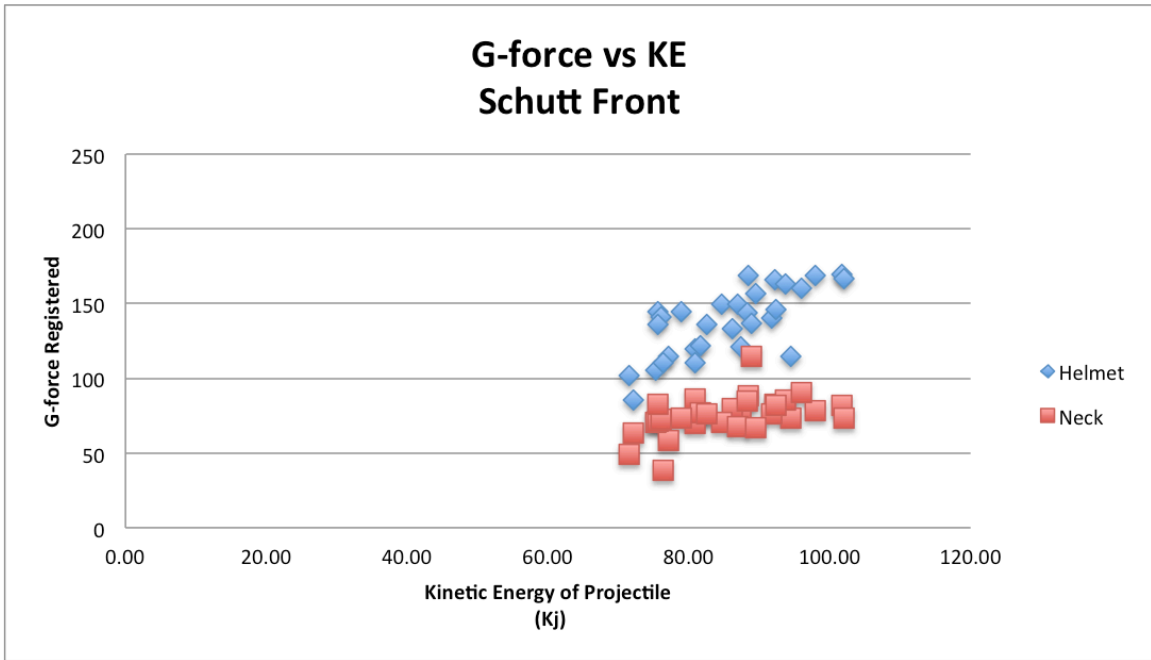

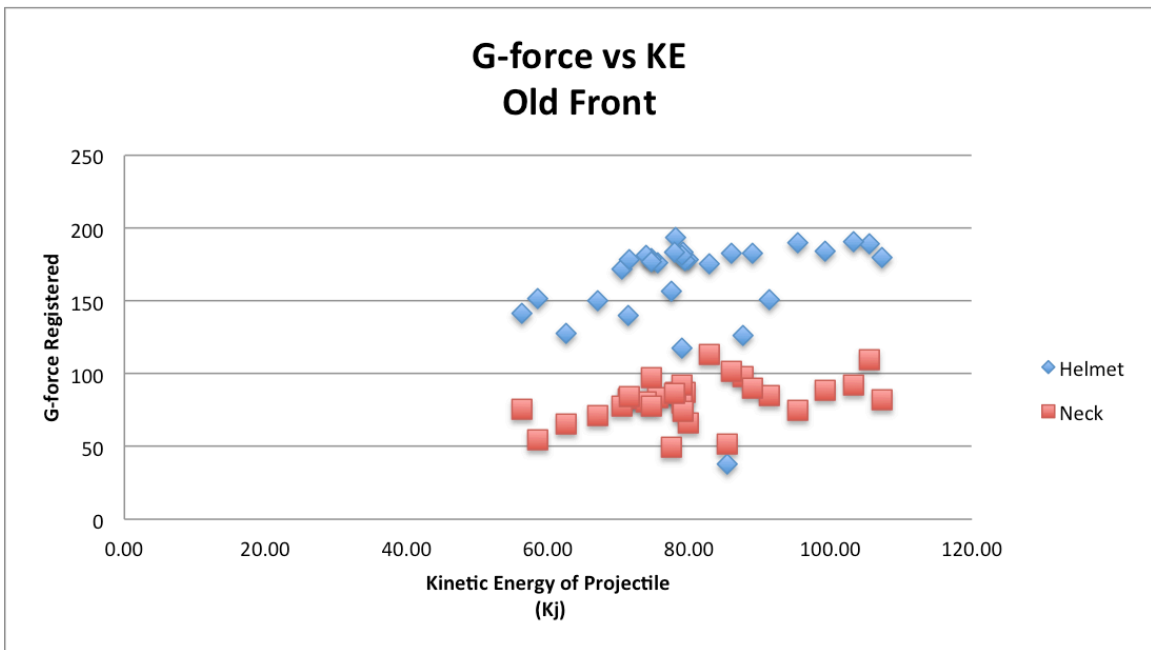
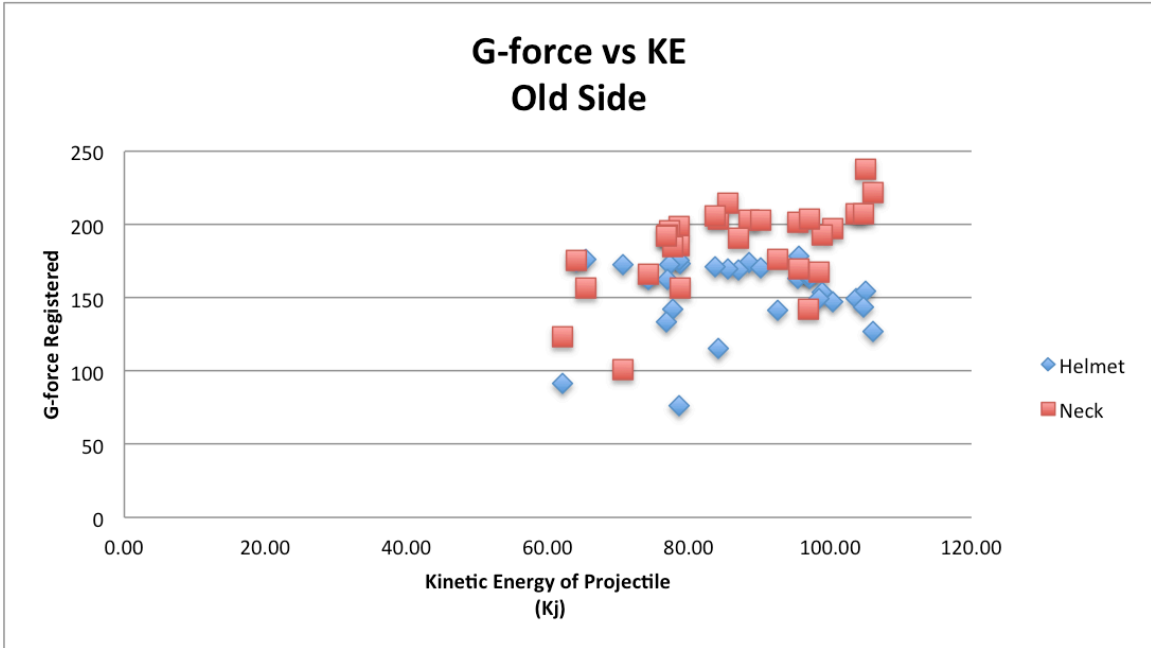

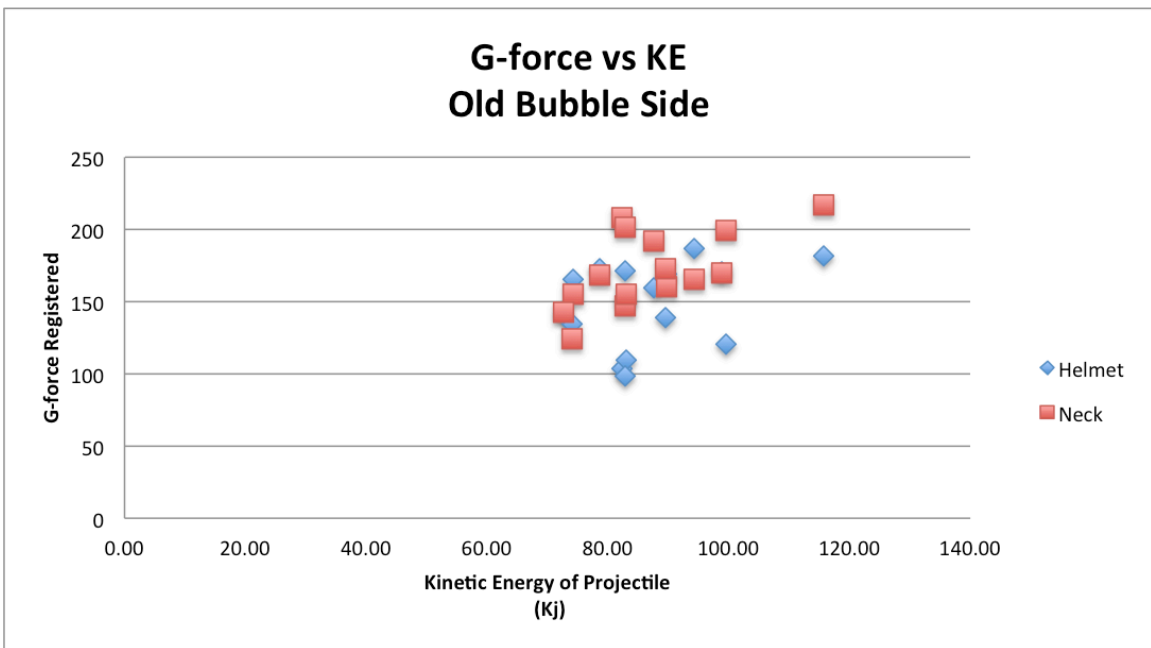
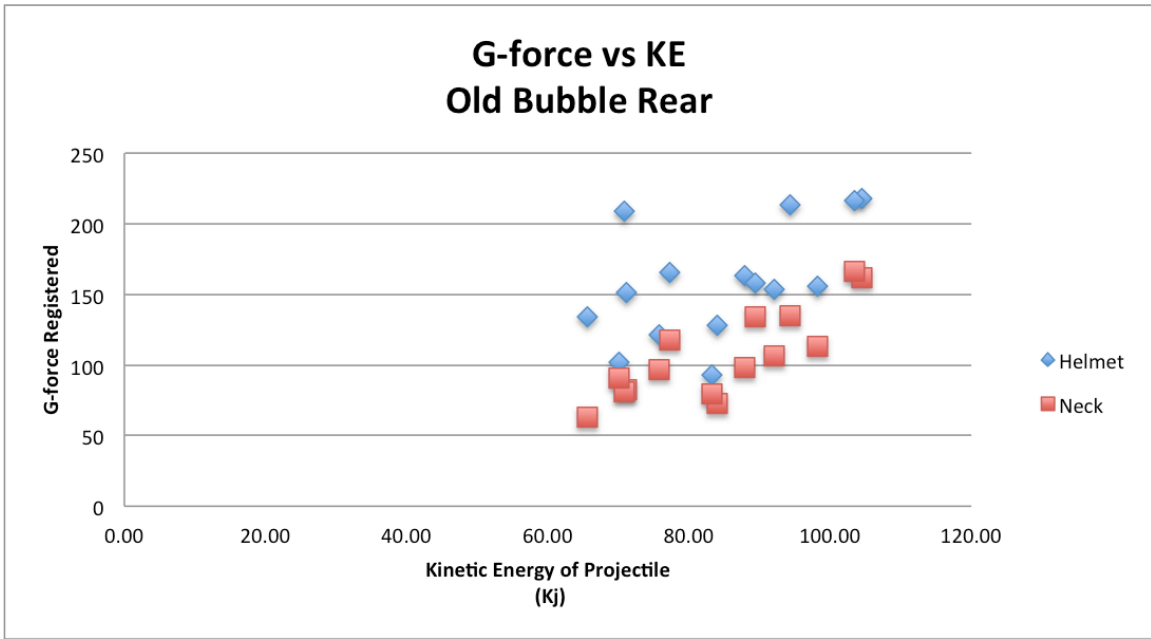

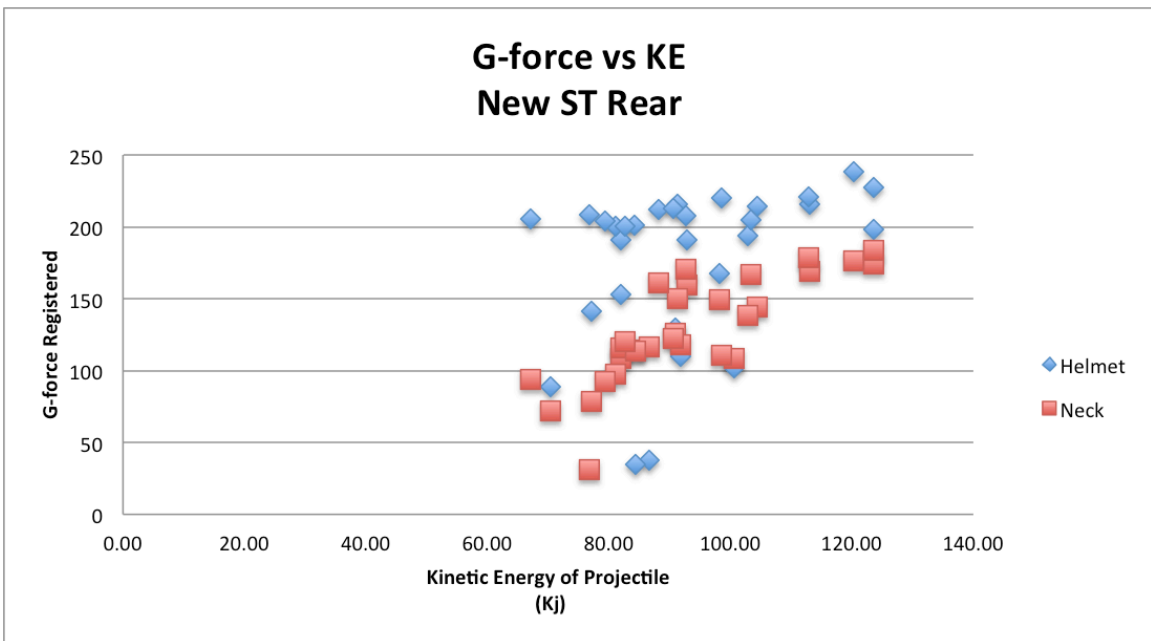
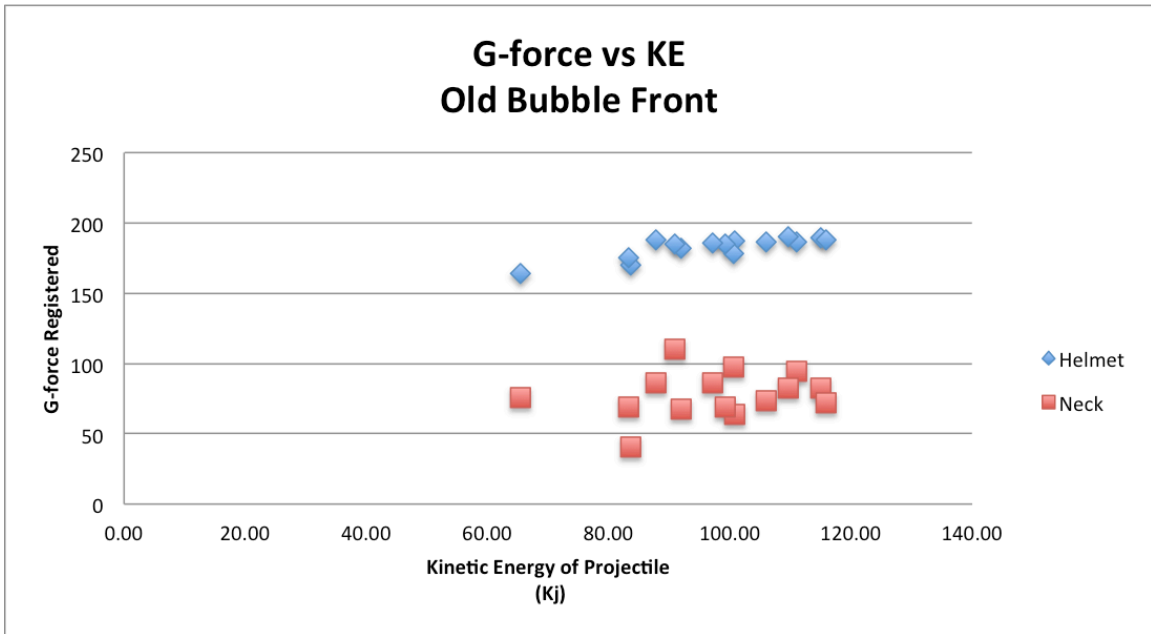

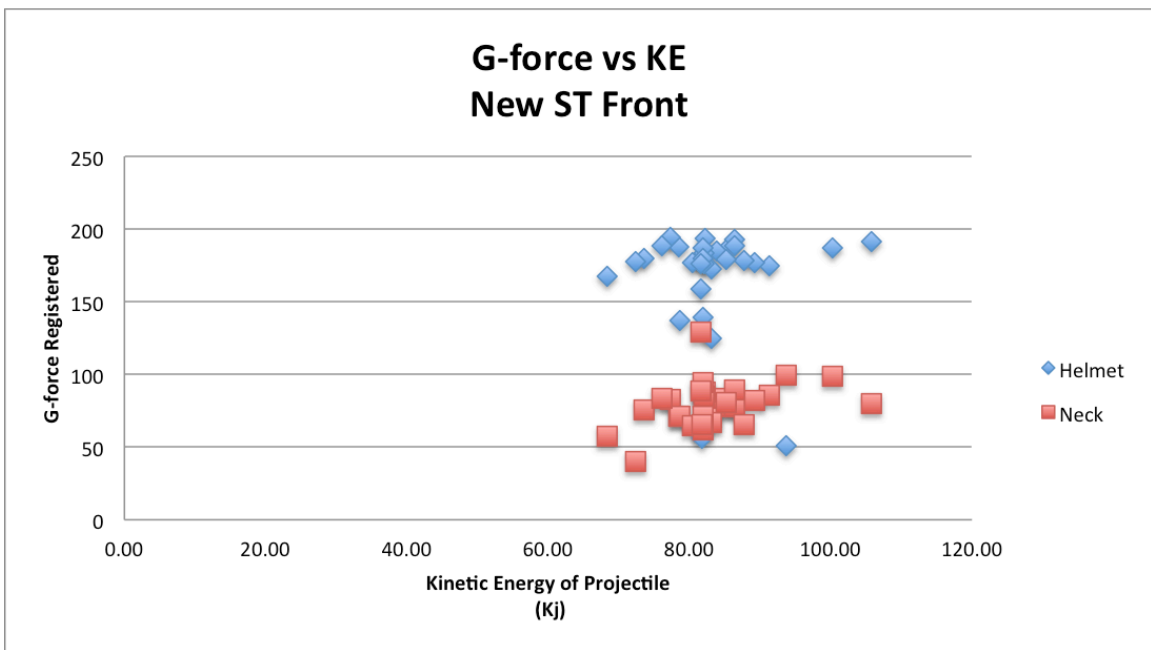
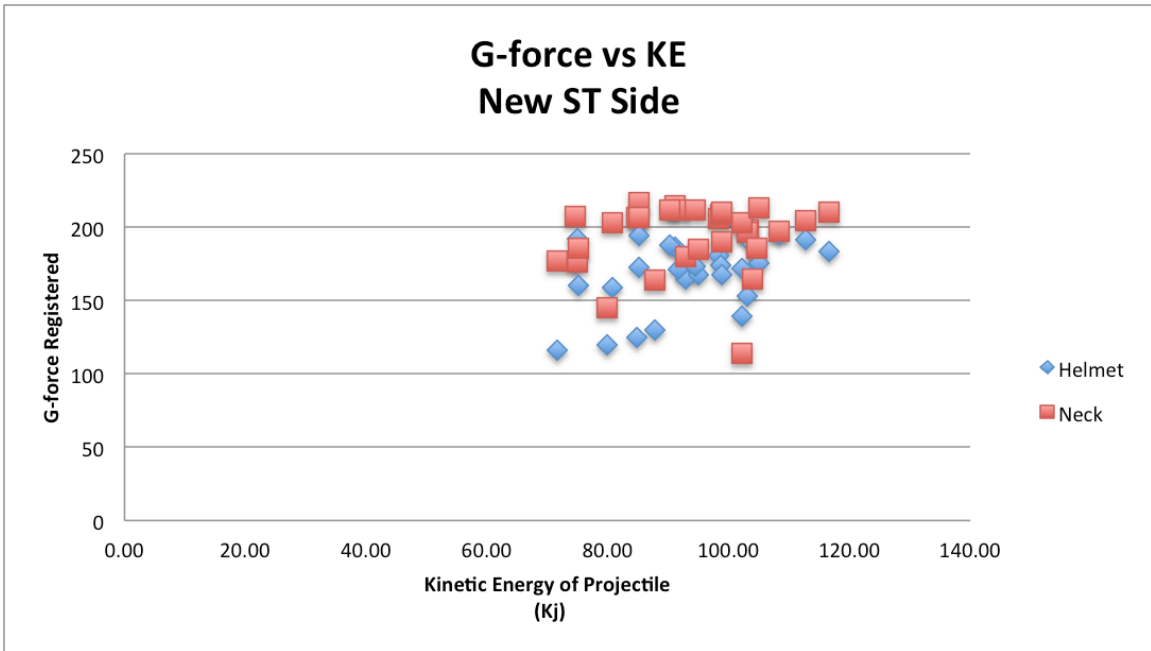

Appendix B. G-Force Tracker suggested mounting locations

