

EVALUATION OF THE MATURITY METHOD TO ESTIMATE CONCRETE
STRENGTH IN FIELD APPLICATIONS

Except where reference is made to the work of others, the work described in this thesis is my own or was done in collaboration with my advisory committee. This thesis does not include proprietary or classified information.

Jeffrey McMillan Nixon

Certificate of Approval:

Robert W. Barnes
Associate Professor
Civil Engineering

Anton K. Schindler, Chair
Gottlieb Assistant Professor
Civil Engineering

Mary L. Hughes
Assistant Professor
Civil Engineering

Stephen L. McFarland
Dean
Graduate School

EVALUATION OF THE MATURITY METHOD TO ESTIMATE CONCRETE
STRENGTH IN FIELD APPLICATIONS

Jeffrey McMillan Nixon

A Thesis

Submitted to

the Graduate Faculty of

Auburn University

in Partial Fulfillment of the

Requirements for the

Degree of

Master of Science

Auburn, Alabama
May 11, 2006

EVALUATION OF THE MATURITY METHOD TO ESTIMATE CONCRETE
STRENGTH IN FIELD APPLICATIONS

Jeffrey McMillan Nixon

Permission is granted to Auburn University to make copies of this thesis at its discretion,
upon request of individuals or institutions and at their expense. The author reserves all
publication rights.

Signature of Author

Date of Graduation

VITA

Jeffrey McMillan Nixon, son of J. Dawson and Barbara May (Smith) Nixon, was born July 9, 1981, in Evanston, Illinois. He graduated from Brookwood High School, in Snellville, Georgia in 1999. He entered Auburn University in September of 1999 and received a Bachelor of Civil Engineering, magna cum laude, in December of 2003. He began graduate school at Auburn University in January of 2004.

THESIS ABSTRACT

EVALUATION OF THE MATURITY METHOD TO ESTIMATE CONCRETE
STRENGTH IN FIELD APPLICATIONS

Jeffrey McMillan Nixon

Master of Science, May 11, 2006
(B.C.E., Auburn University, 2003)

713 Typed Pages

Directed by Anton K. Schindler

Estimating the strength of concrete is essential to contractors and engineers to allow concrete construction operations to proceed safely and expediently. The maturity method is a technique that allows the in-place concrete strength to be estimated using the time and temperature history of freshly placed concrete. The purpose of this project was to evaluate the accuracy of the maturity method to assess concrete strength under field conditions and develop a specification for Alabama Department of Transportation (ALDOT) to implement the maturity method. The field applications investigated were the construction of a precast prestressed girder and the construction of a bridge deck. For each project the accuracy of the maturity method for estimating the in-place strength of concrete was evaluated. A mock girder and mock bridge decks were constructed to test

the in-place strength. The in-place strength was tested with pullout tests, compression testing of cast-in-place cylinders, and compression testing of cores. Also the accuracy of using laboratory-cured specimens versus field-cured specimens for developing the strength-maturity relationship to estimate the in-place strength was evaluated. Seasonal effects on the maturity method were also evaluated during the bridge deck project. The optimum locations of temperature sensors used in estimating the in-place strength were determined in the prestressed girder and bridge deck. Finally the American Society of Testing and Materials (ASTM) Standard ASTM C 1074 recommended procedures for implementing the maturity method were evaluated on the actual bridge decks that were constructed.

It was found that the maturity method may only be accurate for estimating the in-place strength of the concrete up to an equivalent age of seven days. The Nurse-Saul maturity function with a datum temperature of 0 °C (32 °F) was found to be the most accurate function for estimating the strength when considering all projects and variables. When comparing the activation energies for the Arrhenius maturity function, an activation energy of 33,500 J/mol was more accurate for the warm-weather concrete placements, and an activation energy of 40,000 J/mol was more accurate for the cold-weather concrete placements. This supports the results of the laboratory study. The maturity method accurately estimated the pullout and cast-in-place cylinder strengths. The ASTM C 1074 recommended procedures were determined to be useful, but some modifications were recommended for implementation for ALDOT projects. A proposed specification is presented in this thesis.

ACKNOWLEDGMENTS

I would like to thank Samuel Wade for all of his assistance with preparation and testing of the field projects.

I would like to thank my advisor Dr. Anton Schindler for giving me the opportunity, to perform this study, and for the guidance, advice, and time that he provided throughout my college career.

I would like to thank ALDOT for providing the funding and resources available for conducting the field projects.

I would also like to thank my fellow graduate students, undergraduate students, laboratory supervisors Billy Wilson and Curtis Williams, and Auburn University faculty who have worked on or assisted with this project. Without them the project would not have been completed.

I would like to thank Andy Carroll and Scott Bridge Company in Opelika, Alabama for the assistance, expertise, and resources that were given to conduct the field Bridge Project. I would like to thank Paul Gustafson and Sherman Industries in Pelham, Alabama for the assistance, expertise, and resources that were given to conduct the field Prestressed Project.

Special thanks to my father Dawson Nixon, mother Barbara, brother Michael, and sister-in-law Emily. Your support, encouragement, and love have been greatly appreciated.

Style manual or journal used: Chicago Manual of Style, 15th edition

Computer software used: Microsoft Word®, Microsoft Excel®

TABLE OF CONTENTS

LIST OF TABLES	xix
LIST OF FIGURES	xxv
CHAPTER 1: INTRODUCTION	1
1.1 PROJECT OBJECTIVES	3
1.2 RESEARCH APPROACH	4
1.3 REPORT OUTLINE	7
CHAPTER 2: LITERATURE REVIEW	10
2.1 INTRODUCTION	10
2.2 DEFINITION AND DEVELOPMENT OF THE MATURITY METHOD	11
2.2.2 NURSE-SAUL MATURITY FUNCTION (NSM FUNCTION)	13
2.2.3 ARRHENIUS MATURITY FUNCTION (AM FUNCTION)	16
2.2.4 USE OF THE MATURITY METHOD TO ESTIMATE STRENGTH DEVELOPMENT	16
2.3 COMPARISON OF THE MATURITY FUNCTIONS	18
2.3.1 AGE CONVERSION FACTOR	19
2.3.2 TYPICAL DATUM TEMPERATURES VALUES	25
2.3.3 TYPICAL ACTIVATION ENERGY VALUES	27

2.3.4 SUMMARY OF THE TWO MATURITY FUNCTIONS.....	29
2.4 STRENGTH-MATURITY RELATIONSHIPS.....	30
2.5 LIMITATIONS OF THE MATURITY METHOD.....	33
2.5.1 EFFECTS OF CURING TEMPERATURES ON LONG-TERM STRENGTH.....	33
2.5.2 STRENGTH-MATURITY CURVES ARE MIXTURE SPECIFIC.....	37
2.5.3 OTHER FACTORS AFFECTING STRENGTH DEVELOPMENT.....	37
2.6 MATURITY RECORDING DEVICES.....	40
2.6.1 SYSTEM 4101 CONCRETE MATURITY METER.....	41
2.6.2 INTELLIROCK II.....	43
2.6.3 THE COMMAND CENTER.....	45
2.7 APPLICATION OF THE MATURITY METHOD.....	47
2.7.1 DEVELOPING THE STRENGTH-MATURITY RELATIONSHIP.....	47
2.7.2 ESTIMATING THE IN-PLACE STRENGTH.....	50
2.7.3 VERIFICATION OF IN-PLACE STRENGTH.....	51
2.8 IN-PLACE STRENGTH TESTING.....	54
2.8.1 NATURE OF IN-PLACE TESTING.....	54
2.8.2 PULLOUT TEST.....	61
2.8.2.1 Background of the Pullout Test.....	62
2.8.2.2 Failure Mechanism of the Pullout Test.....	65
2.8.2.3 Variability of the Pullout Test.....	70
2.8.2.4 ASTM C 900 Summary.....	74
2.8.2.5 Application of Pullout Test.....	76
2.8.3 COMPRESSIVE STRENGTH OF CORES.....	78

2.8.3.1 Background on Core Testing.....	78
2.8.3.2 Comparison of ASTM C 42 and AASHTO T 24.....	82
2.8.4 COMPRESSIVE TESTING OF CAST-IN-PLACE CYLINDERS	83
2.8.4.1 ASTM C 873 Mold Requirements	84
2.8.4.2 ASTM C 873 Cylinder Casting, Handling, and Testing	86
2.9 SUMMARY	86
CHAPTER 3: REVIEW OF LABORATORY TESTING PHASE.....	89
3.1 BACKGROUND.....	89
3.2 TESTING PROCEDURES	92
3.3 TYPICAL RESULTS.....	95
3.4 MAJOR FINDINGS.....	100
3.5 SUMMARY	103
CHAPTER 4: EVALUATION OF THE MATURITY METHOD FOR PRECAST/PRESTRESSED CONCRETE OPERATIONS.....	104
4.1 EXPERIMENTAL DESIGN.....	104
4.1.1 ANALYSIS APPROACH.....	105
4.1.1.1 Molded Cylinders Strategy.....	105
4.1.1.2 In-Place Strength Strategy.....	107
4.1.2 LAYOUT OF TESTS	108
4.1.2.1 Development of the Strength-Maturity Relationship	108
4.1.2.2 Girder Design	110

4.1.2.3 Verification of Pullout Table.....	117
4.2 RAW MATERIALS AND MIXTURE PROPORTIONS.....	117
4.3 FIELD PROCEDURES AND TESTING	120
4.3.1 FRESH CONCRETE TESTING	120
4.3.1.1 Quality Control Testing.....	120
4.3.1.2 Making and Curing of Specimens	121
4.3.2 HARDENED CONCRETE TESTING.....	125
4.3.2.1 Compression Testing of Molded Cylinders.....	126
4.3.2.2 Pullout Cube Testing.....	126
4.3.3 TEMPERATURE RECORDING	127
4.3.3.2 Temperature Recording for Cylinders and Pullout Cubes	128
4.3.3.3 Temperature Recording for Mock Girder	129
4.3.3.4 Temperature Recording for Cores.....	132
4.3.3.5 Air Temperature Data.....	132
4.3.4 IN-PLACE TESTING	132
4.3.4.1 Pullout Testing	132
4.3.4.2 Compressive Strength of Cores.....	136
4.3.5 DATA ANALYSIS METHODS	138
4.3.5.1 Data Assessment.....	139
4.3.5.2 Strength-Maturity Relationships (S-M Relationships).....	140
4.3.5.3 Calculations of Errors.....	140
4.3.5.4 Confidence Levels.....	142
4.3.5.5 Acceptance Criteria	142

4.4 PRESENTATION OF RESULTS	143
4.4.1 BATCHED MATERIAL AND FRESH CONCRETE PROPERTIES	143
4.4.2 TEMPERATURE DATA	144
4.4.3 STRENGTH DATA	147
4.4.4 STRENGTH-MATURITY RELATIONSHIP (S-M RELATIONSHIP).....	152
4.4.5 IN-PLACE STRENGTH GRAPHS	157
4.5 ANALYSIS OF RESULTS	162
4.5.1 ACCURACY OF VARIOUS MATURITY METHODS.....	162
4.5.2 ACCURACY OF THE PULLOUT TABLE PROVIDED BY LOK-TEST SUPPLIER	168
4.5.3 ACCURACY OF THE MATURITY METHOD TO ASSESS IN-PLACE STRENGTH ..	171
4.5.3.1 Assessing the Estimated In-Place Strengths for the Pullout Test.....	171
4.5.3.2 Assessing the Estimated In-Place Strengths for the Testing of	
Cores.....	182
4.5.3.3 Summary of Accuracy of In-place Strengths	190
4.5.4 EVALUATION OF THE TESTING SCHEDULE	191
4.5.5 EVALUATION OF THE MATURITY METHOD WITH CONFIDENCE LEVELS	193
4.5.6 EVALUATION OF THE TEMPERATURE PROFILE OF THE MOCK GIRDER	195
4.6 SUMMARY AND CONCLUSIONS.....	198
CHAPTER 5: EVALUATION OF THE MATURITY METHOD UNDER BRIDGE	
DECK CONSTRUCTION OPERATIONS	203
5.1 EXPERIMENTAL DESIGN.....	203
5.1.1 ANALYSIS APPROACH.....	204

5.1.1.2 Mock Bridge Deck Testing Design	205
5.1.1.3 Evaluation of the Use of Molded Cylinders for Verification Testing	207
5.1.1.4 Maturity Functions and Strength-Maturity Relationship Evaluations	208
5.1.2 MOCK BRIDGE DECK TESTING LAYOUT	209
5.1.2.1 Assessment of the Curing Conditions for the Molded Cylinders.....	209
5.1.2.2 Design of Mock Bridge Deck.....	210
5.1.2.3 Verification of the Pullout Table.....	216
5.1.3 ACTUAL BRIDGE DECK TESTING LAYOUT	217
5.2 MATERIALS AND PROPERTIES	220
5.3 FIELD PROCEDURES AND TESTING FOR MOCK BRIDGE DECK.....	221
5.3.1 FRESH CONCRETE TESTING	221
5.3.1.1 Quality Control Testing.....	221
5.3.1.2 Making and Curing Specimens	222
5.3.2 HARDENED CONCRETE TESTING.....	224
5.3.2.1 Compression Testing.....	224
5.3.2.2 Pullout Tests Performed on the Molded Cubes.....	225
5.3.3 TEMPERATURE RECORDING EQUIPMENT	225
5.3.3.1 Temperature Recording for Cylinders and Pullout Cubes	225
5.3.3.2 Temperature Recording for Mock Bridge Deck.....	226
5.3.3.3 Temperature Recording for the Cast-In-Place Cylinders	227
5.3.3.4 Temperature Recording for Cores.....	228

5.3.3.5 Air Temperature Data.....	228
5.3.4 IN-PLACE TESTING	229
5.3.4.1 Pullout Testing	229
5.3.4.2 Compressive Strength of Cores.....	232
5.3.4.3 Compressive Testing of Cast-In-Place Cylinders	233
5.4 PROCEDURES FOR THE EVALUATION OF THE USE OF MOLDED CYLINDERS FOR STRENGTH VERIFICATION TESTING	237
5.4.1 QUALITY CONTROL TESTING.....	237
5.4.2 HARDENED CONCRETE	237
5.4.3 DEVELOPING THE STRENGTH-MATURITY RELATIONSHIP	238
5.4.4 ESTIMATING THE IN-PLACE STRENGTH	239
5.4.5 VERIFICATION TESTING	241
5.5 DATA ANALYSIS APPROACH.....	241
5.5.1 DATA INTERPRETATION.....	242
5.5.2 MATURITY CALCULATIONS	243
5.5.3 STRENGTH-MATURITY RELATIONSHIPS.....	243
5.5.4 CALCULATIONS OF ERRORS	243
5.5.5 CONFIDENCE LEVELS.....	244
5.5.6 ACCEPTANCE CRITERIA	245
5.6 MOCK BRIDGE DECK RESULTS	245
5.6.1 COLD-WEATHER PLACEMENT TEST RESULTS	246
5.6.1.1 Fresh Concrete Properties	246
5.6.1.2 Temperature Data	246

5.6.1.3	Strength Data.....	251
5.6.1.4	Strength-Maturity (S-M) Relationships.....	256
5.6.1.5	In-Place Strength Graphs.....	262
5.6.2	WARM-WEATHER PLACEMENT TEST RESULTS	269
5.6.2.1	Fresh Concrete Properties	269
5.6.2.2	Temperature Data	270
5.6.2.3	Strength Data.....	274
5.6.2.4	Strength-Maturity (S-M) Relationships.....	280
5.6.2.5	In-Place Strength Graphs.....	285
5.7	RESULTS FOR THE EVALUATION OF THE USE OF MOLDED CYLINDERS FOR STRENGTH VERIFICATION TESTING	293
5.7.2	FRESH CONCRETE PROPERTIES	294
5.7.3	TEMPERATURE DATA	295
5.7.4	STRENGTH DATA	300
5.7.5	STRENGTH-MATURITY (S-M) RELATIONSHIPS	302
5.8	ANALYSIS AND DISCUSSION OF RESULTS.....	312
5.8.1	DISCUSSION OF THE MOCK BRIDGE DECK RESULTS	313
5.8.1.1	Accuracy of Various Maturity Methods.....	313
5.8.1.2	Accuracy of the Maturity Method to Assess Strength of the 4 x 8 inch Water-Tank-Cured Cylinders	322
5.8.1.3	Accuracy of the Pullout Table Supplied By LOK-Test Supplier	329
5.8.1.4	Accuracy of the Maturity Method to Assess In-Place Strengths.....	331
5.8.1.4.1	<i>Evaluation with Pullout Tests</i>	332

5.8.1.4.2	<i>Evaluation with Cast-in-Place Cylinders</i>	344
5.8.1.4.3	<i>Evaluation with Core Strength</i>	351
5.8.1.4.4	<i>Comparison of In-Place Testing</i>	358
5.8.1.4.5	<i>Summary</i>	360
5.8.2	ACCURACY OF THE USE OF MOLDED CYLINDERS FOR STRENGTH	
	VERIFICATION TESTING.....	361
5.8.2.1	Assessing the I-85 Bridge S-M Relationship	361
5.8.2.2	Assessing the Verification Test Results	367
5.8.3	EVALUATION OF THE TESTING SCHEDULE	372
5.8.4	EVALUATION OF THE CONFIDENCE LEVELS	375
5.8.5	EVALUATION OF THE TEMPERATURE PROFILE OF THE BRIDGE DECKS	381
5.9	SUMMARY AND CONCLUSIONS.....	385
CHAPTER 6:	IMPLEMENTATION OF THE MATURITY METHOD	390
6.1	STATE DEPARTMENT OF TRANSPORTATION PRACTICES	390
6.1.1	TXDOT MATURITY METHOD SPECIFICATION TEX-426-A	391
6.1.1.1	Developing the Strength-Maturity Relationship	391
6.1.1.2	Estimating the In-Place Strength.....	392
6.1.1.3	Verifying the Strength-Maturity Relationship	393
6.1.2	IOWA MATURITY METHOD SPECIFICATION IM 383	394
6.1.2.1	Developing the Strength-Maturity Relationship	394
6.1.2.2	Estimating the In-Place Strength.....	396
6.1.2.3	Verifying the Strength-Maturity Relationship	396

6.1.3 INDIANA MATURITY METHOD SPECIFICATION ITM 402-04T	397
6.1.3.1 Developing the Strength-Maturity Relationship	397
6.1.3.2 Estimating the In-Place Strength.....	398
6.1.3.3 Verifying the Strength-Maturity Relationship	398
6.2 NECESSARY REQUIREMENTS FOR IMPLEMENTATION	399
6.2.1 MATURITY FUNCTION AND CORRESPONDING VALUES	399
6.2.2 TEMPERATURE RECORDING OR MATURITY RECORDING DEVICES	400
6.2.3 DEVELOPING THE STRENGTH-MATURITY RELATIONSHIP	402
6.2.4 ESTIMATING THE IN-PLACE STRENGTH	412
6.2.5 VERIFYING THE STRENGTH-MATURITY RELATIONSHIP	414
6.3 SUMMARY	416
CHAPTER 7: CONCLUSIONS AND RECOMMENDATIONS	417
7.1 CONCLUSIONS	420
7.2 RECOMMENDATIONS	425
REFERENCES	429
APPENDIX A: PULLOUT TABLE BY GERMANN INSTRUMENTS.....	438
APPENDIX B: EVALUATION OF THE MATURITY METHOD FOR PRECAST/PRESTRESSED CONCRETE OPERATIONS	447
APPENDIX C: EVALUATION OF THE MATURITY METHOD UNDER BRIDGE DECK CONSTRUCTION CONDITIONS	513

C.1. COLD-WEATHER PLACEMENT OF MOCK BRIDGE DECK	
RESULTS	514
C.2. WARM-WEATHER PLACEMENT OF MOCK BRIDGE DECK	
RESULTS	543
C.3. EVALUATION OF THE USE OF MOLDED CYLINDERS FOR	
VERIFICATION TESTING.....	572
C.4. ACCURACY OF THE MATURITY METHOD	590
C.5. PICTURES OF MOCK BRIDGE DECK.....	601
C.6. PICTURES OF EVALUATION OF ASTM C 1074.....	613
APPENDIX D: PROPOSED ALDOT MATURITY SPECIFICATION.....	619
APPENDIX E: TEXAS DOT MATURITY SPECIFICATION TEX-426-A	634
APPENDIX F: IOWA DOT MATURITY SPECIFICATION IM 383.....	648
APPENDIX G: INDIANA DOT MATURITY SPECIFICATION ITM 402-04T.....	661

LIST OF TABLES

Table 2-1:	Datum temperature values proposed by Carino and Tank (1992)	26
Table 2-2:	Activation energy values proposed by various researchers (Carino 1991)	28
Table 2-3:	Activation energy values proposed by Carino and Tank (1992)	29
Table 2-4:	One-sided tolerance factor (K) for 10% defect level (Odeh and Owen 1980)	59
Table 2-5:	Summary of within-test coefficient of variation of pullout test (ACI 228.1R 2003)	72
Table 3-1:	Concrete mixtures evaluated in the laboratory phase	90
Table 3-2:	Laboratory testing schedules	94
Table 4-1:	Mock girder mixture proportions	119
Table 4-2:	Material properties for prestressed girder project	120
Table 4-3:	Coefficient of variation of test methods	142
Table 4-4:	Fresh concrete properties for prestressed girder project concrete	144
Table 4-5:	Laboratory cylinders strength and maturity data	147
Table 4-6:	Lime-saturated water-tank cylinders strength and maturity data	148
Table 4-7:	Damp-sand-pit cylinder strength and maturity data	148
Table 4-8:	In-place top pullout strength and maturity data	150
Table 4-9:	In-place side pullout strength and maturity data	150
Table 4-10:	In-place ASTM C 42 core strength and maturity data	151

Table 4-11:	In-place AASHTO T 24 core strength and maturity data	151
Table 4-12:	Pullout cube strength and maturity data.....	151
Table 4-13:	Evaluation of the errors of the laboratory S-M relationship for the laboratory-cured cylinders	163
Table 4-14:	Percent errors and average absolute errors for field-cured cylinder data using laboratory S-M relationships	164
Table 4-15:	Percent error for pullout cube strength from water-tank S-M relationship.....	169
Table 4-16:	Errors for pullout test using laboratory S-M relationship.....	172
Table 4-17:	Percent errors for pullout test using water-tank S-M relationship	176
Table 4-18:	Percent errors for pullout test using sand-pit S-M relationship	178
Table 4-19:	Percent errors for core test using laboratory S-M relationship	183
Table 4-20:	Percent errors for core test using water-tank S-M relationship	185
Table 4-21:	Percent errors for core test using sand-pit S-M relationship.....	186
Table 5-1:	Bridge deck concrete mixture proportions.....	220
Table 5-2:	Material properties for bridge deck.....	221
Table 5-3:	Coefficient of variation of test methods.....	244
Table 5-4:	Fresh concrete properties for the cold-weather placement mock bridge deck	246
Table 5-5:	Laboratory-cured cylinders strength and maturity data for cold-weather placement of mock bridge deck	251
Table 5-6:	6 x 12 inch Water-tank-cured cylinder strength and maturity data for the cold-weather placement of the mock bridge deck	251
Table 5-7:	In-place top pullout strength and maturity data for cold-weather placement of mock bridge deck	253
Table 5-8:	In-place side pullout strength and maturity data for cold-weather placement of mock bridge deck	253

Table 5-9:	In-place bottom pullout strength and maturity data for cold-weather placement of mock bridge deck	254
Table 5-10:	ASTM C 42 core strength and maturity data for the cold-weather placement of the mock bridge deck	254
Table 5-11:	AASHTO T 24 core strength and maturity data for the cold-weather placement of the mock bridge deck	255
Table 5-12:	Pullout strength and maturity data from the cubes for cold-weather placement of mock bridge deck	255
Table 5-13:	CIP cylinders strength and maturity data for the cold-weather placement of the mock bridge deck	256
Table 5-14:	4 x 8 inch water-tank-cured cylinder strength and maturity data for the cold-weather placement of the mock bridge deck	256
Table 5-15:	Fresh concrete properties for the warm-weather placement mock bridge deck	270
Table 5-16:	Laboratory-cured cylinders strength and maturity data for warm-weather placement of mock bridge deck	275
Table 5-17:	6 x 12 inch water-tank-cured cylinder strength and maturity data for the warm-weather placement of the mock bridge deck	275
Table 5-18:	In-place top pullout strength and maturity data for warm-weather placement of mock bridge deck	277
Table 5-19:	In-place side pullout strength and maturity data for warm-weather placement of mock bridge deck	277
Table 5-20:	In-place bottom pullout strength and maturity data for warm-weather placement of mock bridge deck	277
Table 5-21:	ASTM C 42 core strength and maturity data for the warm-weather placement of the mock bridge deck	278
Table 5-22:	AASHTO T 24 core strength and maturity data for the warm-weather placement of the mock bridge deck	278
Table 5-23:	Pullout strength and maturity data from the cubes for warm-weather placement of mock bridge deck	279

Table 5-24:	CIP cylinders strength and maturity data for the warm-weather placement of the mock bridge deck	279
Table 5-25:	4 x 8 inch water-tank cured cylinder strength and maturity data for the warm-weather placement of the mock bridge deck	280
Table 5-26:	Notation for the different testing locations on the two bridge decks	293
Table 5-27:	Fresh concrete properties for evaluation of the use of molded cylinders for verification testing	294
Table 5-28:	I-85 Bridge Sample D cylinders strength and maturity data.....	301
Table 5-29:	Creek Bridge Sample A cylinders strength and maturity data.....	301
Table 5-30:	Verification test cylinders strength and maturity data	302
Table 5-31:	Evaluation of the errors of the laboratory S-M relationship for cold-weather placement laboratory-cured cylinders	314
Table 5-32:	Evaluation of the errors of the laboratory S-M relationship for warm-weather placement laboratory-cured cylinders	314
Table 5-33:	Percent errors and average absolute percent errors for water-tank-cured cylinder data using laboratory S-M relationships for the cold-weather placement of the mock bridge deck.....	316
Table 5-34:	Percent errors and average absolute percent errors for water-tank-cured cylinder data using laboratory S-M relationships for the warm-weather placement of the mock bridge deck.....	316
Table 5-35:	Percent errors for water-tank-cured 4 x 8 inch cylinder using laboratory S-M relationship for the cold-weather placement	323
Table 5-36:	Percent errors for water-tank-cured 4 x 8 inch cylinder using laboratory S-M relationship for the warm-weather placement	323
Table 5-37:	Percent errors for 4 x 8 inch cylinder strengths using water-tank S-M relationship for the cold-weather placement.....	326
Table 5-38:	Percent errors for 4 x 8 inch cylinder strengths using water-tank S-M relationship for the warm-weather placement	326

Table 5-39:	Percent error for pullout cube strength from water-tank S-M relationship.....	331
Table 5-40:	Percent errors for pullout test using laboratory S-M relationship from the cold-weather placement	333
Table 5-41:	Percent errors for pullout test using laboratory S-M relationship from the warm-weather placement	334
Table 5-42:	Percent errors for pullout test using water-tank S-M relationship for the cold-weather placement	339
Table 5-43:	Percent errors for pullout test using water-tank S-M relationship for the warm-weather placement	340
Table 5-44:	Percent errors for CIP cylinder test using laboratory S-M relationship for the cold-weather placement.....	345
Table 5-45:	Percent errors for CIP cylinder test using laboratory S-M relationship for the warm-weather placement	345
Table 5-46:	Percent errors for CIP cylinder test using water-tank S-M relationship for the cold-weather placement.....	348
Table 5-47:	Percent errors for CIP cylinder test using water-tank S-M relationship for the warm-weather placement	348
Table 5-48:	Percent errors for core tests using laboratory S-M relationship for the cold-weather placement	352
Table 5-49:	Percent errors for core tests using laboratory S-M relationship for the warm-weather placement	352
Table 5-50:	Percent errors for core tests using water-tank S-M relationship for the cold-weather placement	355
Table 5-51:	Percent errors for core tests using water-tank S-M relationship for the warm-weather placement	355
Table 5-52:	Evaluation of the errors of the I-85 S-M relationship I-85 D cylinders...	362
Table 5-53:	Percent errors for Creek A cylinder data using I-85 Bridge S-M relationships	363

Table 5-54:	Percent errors for verification testing using I-85 Bridge S-M relationships	368
Table 6-1:	Approximate maturity values for testing (IM 383 2004).....	395
Table 6-2:	Testing ages for normal-strength concrete.....	406
Table 6-3:	The percent reduction in each confidence level with 10% defect level reduces the best-fit S-M relationship	411

LIST OF FIGURES

Figure 1-1:	Report organization.....	7
Figure 2-1:	Diagram showing the effect of temperature histories on maturity calculation	12
Figure 2-2:	Diagram of concrete temperature over time and the Nurse-Saul maturity function.....	15
Figure 2-3:	Strength versus concrete age of a concrete mixture cured at different temperatures (Type I + 30% Class C Fly Ash) (Wade 2005)	17
Figure 2-4:	Strength-maturity relationship using the NSM function for Figure 2-3 ($T_o = 0\text{ }^\circ\text{C}$).....	18
Figure 2-5:	Effect of datum temperatures on the age conversion factor determined with the NSM function (Carino 1984)	21
Figure 2-6:	Effect of the activation energies on the age conversion factor determined with the AM function (Carino 1984)	22
Figure 2-7:	Comparing Arrhenius maturity function with $E = 40\text{ kJ/mol}$ to Nurse-Saul maturity function with $T_o = 0\text{ }^\circ\text{C}$ ($32\text{ }^\circ\text{F}$) (Carino 1984)	23
Figure 2-8:	Comparing percent difference α of AM function with $E = 40\text{ kJ/mol}$ to the NSM function with $T_o = 0\text{ }^\circ\text{C}$ ($32\text{ }^\circ\text{F}$).....	24
Figure 2-9:	Comparison of strength-maturity relationships (Carino 1991).....	32
Figure 2-10:	Compressive strength versus age for concrete cylinders cured at three temperatures (Type I cement, $w/c = 0.55$) (Carino 1991).....	36
Figure 2-11:	Compressive strength versus equivalent age (Carino 1991).....	36
Figure 2-12:	Relationship between air content and 28-day compressive strength for concrete at three cement contents. Water content was reduced with increased air content to maintain a constant slump (Cordon 1946).....	38

Figure 2-13:	Effect of moist-curing time on strength gain of concrete (Gonnerman and Shuman 1928)	40
Figure 2-14:	Humboldt system 4101 concrete maturity meter	42
Figure 2-15:	intelliROCK II console and sensor (Source: Engius Construction Intelligence)	44
Figure 2-16:	Pocket PC used with The COMMAND Center System (Source: The Transtec Group)	46
Figure 2-17:	The COMMAND Center temperature sensor	47
Figure 2-18:	Example of a strength-maturity relationship using Nurse-Saul maturity function with $T_o = 0\text{ }^{\circ}\text{C}$	49
Figure 2-19:	Example of estimating the in-place strength of the concrete	51
Figure 2-20:	Strength for a population of concrete.....	56
Figure 2-21:	Confidence level for a strength-maturity relationship	60
Figure 2-22:	Pullout test equipment.....	62
Figure 2-23:	Schematic of the pullout test (Carino 1991)	63
Figure 2-24:	Kierkegaard-Hansen's configuration for the pullout test (Carino 1991)	64
Figure 2-25:	Sequence based on NBS large-scale pullout test (Carino 1991).....	66
Figure 2-26:	Model to illustrate aggregate interlock mechanism during pullout test (Carino 1991)	67
Figure 2-27:	Failure mechanism of pullout test according to Krenchel and Bickley (Carino 1991)	68
Figure 2-28:	Repeatability of the pullout test for different aggregates from Stone, Carino, and Reeve study (Carino 1991).....	70
Figure 2-29:	Coefficient of variation as a function of: (A) apex angle, (B) embedment depth, (C) maximum aggregate size, and (D) aggregate type (Carino 1991)	73
Figure 2-30:	Form-mounted pullout inserts.....	77

Figure 2-31:	Floating pullout inserts	77
Figure 2-32:	ASTM recommendation for the cast-in-place concrete cylinders molds (ASTM C 873 2003)	85
Figure 3-1:	Temperature cycles of the three curing methods (Wade 2005)	93
Figure 3-2:	Curing tank and programmable heating/cooling circulator	93
Figure 3-3:	Compressive strength versus age results for Type I – 0.41 mixture (Wade 2005).....	95
Figure 3-4:	Compressive strength versus age results for Type I – 0.48 mixture (Wade 2005).....	96
Figure 3-5:	Compressive strength versus age results for 20% Class F fly ash mixture (Wade 2005)	96
Figure 3-6:	Compressive strength versus age results for 30% Class F fly ash mixture (Wade 2005)	97
Figure 3-7:	Compressive strength versus age results for 20% Class C fly ash mixture (Wade 2005)	97
Figure 3-8:	Compressive strength versus age results for 30% Class C fly ash mixture (Wade 2005)	98
Figure 3-9:	Compressive strength versus age results for 30% Slag mixture (Wade 2005).....	98
Figure 3-10:	Compressive strength versus age results for 50% Slag mixture (Wade 2005).....	99
Figure 4-1:	Testing performed for the prestressed concrete plant	105
Figure 4-2:	Assumed temperature profile for prestressed girder	110
Figure 4-3:	Cross-sectional reinforcement configuration for mock girder	112
Figure 4-4:	Side view of formwork, steel reinforcement, and access panels	112
Figure 4-5:	Plan view of mock girder	113
Figure 4-6:	Elevation views of mock girder	114

Figure 4-7:	iButton Tree layout	116
Figure 4-8:	Sherman's batch plant.....	118
Figure 4-9:	Casting of concrete specimens.....	121
Figure 4-10:	Curing tarp over the specimens and mock girder	122
Figure 4-11:	Lime-saturated water-tank	123
Figure 4-12:	Damp-sand-pit.....	123
Figure 4-13:	Pullout cube molds.....	125
Figure 4-14:	A typical iButton.....	127
Figure 4-15:	Cylinder and cube temperature-recording device	129
Figure 4-16:	iButton tree.....	130
Figure 4-17:	iButton attached to a stirrup.....	130
Figure 4-18:	(a) iButton Tree 4 installed on a stirrup and (b) Lead wires with phone jacks.....	131
Figure 4-19:	Floating inserts.....	134
Figure 4-20:	Side-mounted pullout inserts on mock girder forms.....	135
Figure 4-21:	Mock girder form with pullout inserts and stirrups	135
Figure 4-22:	Access panels in mock girder forms	136
Figure 4-23:	Temperature history of the molded specimens and the mock girder	145
Figure 4-24:	Temperature history of the 7-day cores	146
Figure 4-25:	Temperature history of the 28-day cores	146
Figure 4-26:	Concrete strength versus concrete age.....	149
Figure 4-27:	S-M relationships using the Nurse-Saul maturity function with $T_0 = -10\text{ }^{\circ}\text{C}$	152

Figure 4-28:	S-M relationships using the Nurse-Saul maturity function with $T_o = 0\text{ }^\circ\text{C}$	153
Figure 4-29:	S-M relationships using the Arrhenius maturity function with $E = 33.5\text{ kJ/mol}$	153
Figure 4-30:	S-M relationships using the Arrhenius maturity function with $E = 40\text{ kJ/mol}$	154
Figure 4-31:	Laboratory S-M relationship with confidence levels ($T_o = -10\text{ }^\circ\text{C}$).....	155
Figure 4-32:	Laboratory S-M relationship with confidence levels ($T_o = 0\text{ }^\circ\text{C}$).....	155
Figure 4-33:	Laboratory S-M relationship with confidence levels ($E = 33.5\text{ kJ/mol}$)	156
Figure 4-34:	Laboratory S-M relationship with confidence levels ($E = 40\text{ kJ/mol}$)....	156
Figure 4-35:	Pullout test with laboratory S-M relationship and confidence levels ($T_o = -10\text{ }^\circ\text{C}$)	158
Figure 4-36:	Pullout test with laboratory S-M relationship and confidence levels ($T_o = 0\text{ }^\circ\text{C}$).....	158
Figure 4-37:	Pullout test with laboratory S-M relationship and confidence levels ($E = 33.5\text{ kJ/mol}$)	159
Figure 4-38:	Pullout test with laboratory S-M relationship and confidence levels ($E = 40\text{ kJ/mol}$)	160
Figure 4-39:	Cores with laboratory S-M relationship and confidence levels ($T_o = -10\text{ }^\circ\text{C}$)	160
Figure 4-40:	Cores with laboratory S-M relationship and confidence levels ($T_o = 0\text{ }^\circ\text{C}$).....	160
Figure 4-41:	Cores with laboratory S-M relationship and confidence levels ($E = 33.5\text{ kJ/mol}$)	161
Figure 4-42:	Cores with laboratory S-M relationship and confidence levels ($E = 40\text{ kJ/mol}$)	161
Figure 4-43:	45°-line graph for estimated cylinder strengths from the laboratory S-M relationship using the Nurse-Saul maturity function ($T_o = -10\text{ }^\circ\text{C}$)	165

Figure 4-44:	45°-line graph for estimated cylinder strengths from the laboratory S-M relationship using the Nurse-Saul maturity function ($T_o = 0\text{ }^{\circ}\text{C}$) ...	165
Figure 4-45:	45°-line graph for estimated cylinder strengths from the laboratory S-M relationship using the Arrhenius maturity function ($E = 33.5\text{ kJ/mol}$)	166
Figure 4-46:	45°-line graph for estimated cylinder strengths from the laboratory S-M relationship using the Arrhenius maturity function ($E = 40\text{ kJ/mol}$)	166
Figure 4-47:	45°-line graph to evaluate the pullout table using estimated strength from water-tank S-M relationship using the Nurse-Saul maturity function ($T_o = 0\text{ }^{\circ}\text{C}$)	169
Figure 4-48:	45°-line graph to evaluate the pullout table using estimated strength from water-tank S-M relationship using the Arrhenius maturity function ($E = 40\text{ kJ/mol}$)	170
Figure 4-49:	45°-line graph for estimating the strength of pullout test on the mock girder using laboratory S-M relationship with Nurse-Saul maturity function ($T_o = 0\text{ }^{\circ}\text{C}$)	172
Figure 4-50:	45°-line graph for estimating the strength of pullout test on the mock girder using laboratory S-M relationship with Arrhenius maturity function ($E = 40\text{ kJ/mol}$)	173
Figure 4-51:	45°-line graph for estimating the strength of pullout test on the mock girder using water-tank S-M relationship with Nurse-Saul maturity function ($T_o = 0\text{ }^{\circ}\text{C}$)	176
Figure 4-52:	45°-line graph for estimating the strength of pullout test on the mock girder using water-tank S-M relationship with Arrhenius maturity function ($E = 40\text{ kJ/mol}$)	177
Figure 4-53:	45°-line graph for estimating the strength of pullout test on the mock girder using sand-pit S-M relationship with Nurse-Saul maturity function ($T_o = 0\text{ }^{\circ}\text{C}$)	178
Figure 4-54:	45°-line graph for estimating the strength of pullout test on the mock girder using sand-pit S-M relationship with Arrhenius maturity function ($E = 40\text{ kJ/mol}$)	179

Figure 4-55:	45°-line graph for estimating the strength of cores for the mock girder using laboratory S-M relationship with Nurse-Saul maturity function ($T_o = 0\text{ }^{\circ}\text{C}$).....	184
Figure 4-56:	45°-line graph for estimating the strength of cores for the mock girder using laboratory S-M relationship with Arrhenius maturity function ($E = 40\text{ kJ/mol}$)	184
Figure 4-57:	45°-line graph for estimating the strength of cores for the mock girder using water-tank S-M relationship with Nurse-Saul maturity function ($T_o = 0\text{ }^{\circ}\text{C}$).....	186
Figure 4-58:	45°-line graph for estimating the strength of cores for the mock girder using water-tank S-M relationship with Arrhenius maturity function ($E = 40\text{ kJ/mol}$)	187
Figure 4-59:	45°-line graph for estimating the strength of cores for the mock girder using sand-pit S-M relationship with Nurse-Saul maturity function ($T_o = 0\text{ }^{\circ}\text{C}$).....	187
Figure 4-60:	45°-line graph for estimating the strength of cores for the mock girder using sand-pit S-M relationship with Arrhenius maturity function ($E = 40\text{ kJ/mol}$)	188
Figure 4-61:	Compressive strength from the pullout test versus the cores for the 7- and 28-day testing ages.....	190
Figure 4-62:	Evaluation of the testing ages for the prestressed girder project	192
Figure 4-63:	50% confidence level S-M relationship for the prestressed girder project	195
Figure 4-64:	Concrete temperature histories of iButton Tree 4.....	196
Figure 4-65:	Temperature profile along the girder at location C.....	197
Figure 5-1:	Planned research for bridge deck project.....	205
Figure 5-2:	In-place testing layout for the mock bridge deck.....	212
Figure 5-3:	Steel reinforcement layout of the mock bridge deck	214
Figure 5-4:	Plan view of iButton locations for the mock bridge deck.....	215
Figure 5-5:	Mock bridge deck structure	216

Figure 5-6:	Diagram of the iButtons at each location.....	218
Figure 5-7:	Temperature sensor layout for the I-85 Bridge.....	218
Figure 5-8:	Temperature sensors layout for the Creek bridge	219
Figure 5-9:	Casting of concrete specimens.....	222
Figure 5-10:	iButtons installed in the mock bridge deck.....	227
Figure 5-11:	iButtons embedded in the cast-in-place cylinders	228
Figure 5-12:	Top pullout inserts for the mock bridge deck	230
Figure 5-13:	Side and bottom pullout inserts.....	231
Figure 5-14:	Reinforcement and pullout inserts	231
Figure 5-15:	Side and bottom access panels.....	232
Figure 5-16:	Cast-in-place cylinders installed in the mock bridge deck	234
Figure 5-17:	Cast-in-place cylinder after concrete was placed.....	235
Figure 5-18:	Removal of the cast-in-place cylinders.....	236
Figure 5-19:	iButtons installed in the bridge decks	240
Figure 5-20:	iButton wires exiting the concrete	240
Figure 5-21:	Temperature history of 6 x 12 inch cylinders and the mock bridge deck for the cold-weather placement	248
Figure 5-22:	Temperature history of pullout cubes, 4 x 8 inch water-tank cylinders, and 28-day CIP cylinders for the cold-weather placement	249
Figure 5-23:	Temperature history of 10-day cores for cold-weather placement of mock bridge deck.....	250
Figure 5-24:	Temperature history of 28-day cores for cold-weather placement of mock bridge deck.....	250
Figure 5-25:	Concrete strength versus concrete age for cold-weather placement of mock bridge deck.....	252

Figure 5-26:	S-M relationships using the Nurse-Saul maturity function for mock bridge deck cold-weather placement ($T_o = -10\text{ }^\circ\text{C}$)	257
Figure 5-27:	S-M relationships using the Nurse-Saul maturity function for mock bridge deck cold-weather placement ($T_o = 0\text{ }^\circ\text{C}$).....	258
Figure 5-28:	S-M relationships using the Arrhenius maturity function for mock bridge deck cold-weather placement ($E = 33.5\text{ kJ/mol}$)	258
Figure 5-29:	S-M relationships using the Arrhenius maturity function for mock bridge deck cold-weather placement ($E = 40\text{ kJ/mol}$)	259
Figure 5-30:	S-M relationship for the laboratory cured cylinders with confidence levels for the cold-weather placement of the mock bridge deck ($T_o = -10\text{ }^\circ\text{C}$)	260
Figure 5-31:	S-M relationship for the laboratory cured cylinders with confidence levels for the cold-weather placement of the mock bridge deck ($T_o = 0\text{ }^\circ\text{C}$).....	260
Figure 5-32:	S-M relationship for the laboratory cured cylinders with confidence levels for the cold-weather placement of the mock bridge deck ($E = 33.5\text{ kJ/mol}$)	261
Figure 5-33:	S-M relationship for the laboratory cured cylinders with confidence levels for the cold-weather placement of the mock bridge deck ($E = 40\text{ kJ/mol}$)	261
Figure 5-34:	Pullout test with laboratory S-M relationship and confidence levels for the cold-weather placement of the mock bridge deck ($T_o = 0\text{ }^\circ\text{C}$).....	263
Figure 5-35:	Pullout test with laboratory S-M relationship and confidence levels for the cold-weather placement of the mock bridge deck ($E = 33.5\text{ kJ/mol}$)	264
Figure 5-36:	Pullout test with water-tank S-M relationship and confidence levels for the cold-weather placement of mock bridge deck ($T_o = 0^\circ\text{C}$).....	264
Figure 5-37:	Pullout test with water-tank S-M relationship and confidence levels for the cold-weather placement of mock bridge deck ($E = 33.5\text{ kJ/mol}$)	265

Figure 5-38:	Cast-in-place cylinders and 4 x 8 inch cylinders with laboratory S-M relationship and confidence levels for the cold-weather placement of the mock bridge deck ($T_o = 0\text{ }^\circ\text{C}$)	265
Figure 5-39:	Cast-in-place cylinders and 4 x 8 inch cylinders with laboratory S-M relationship and confidence levels for the cold-weather placement of the mock bridge deck ($E = 33.5\text{ kJ/mol}$).....	266
Figure 5-40:	Cast-in-place cylinders and 4 x 8 inch cylinders with water-tank S-M relationship and confidence levels for the cold-weather placement of mock bridge deck ($T_o = 0^\circ\text{C}$).....	266
Figure 5-41:	Cast-in-place cylinders and 4 x 8 inch cylinders with water-tank S-M relationship and confidence levels for the cold-weather placement of mock bridge deck ($E = 33.5\text{ kJ/mol}$).....	267
Figure 5-42:	Cores with laboratory S-M relationship and confidence levels for the cold-weather placement of the mock bridge deck ($T_o = 0\text{ }^\circ\text{C}$)	267
Figure 5-43:	Cores with laboratory S-M relationship and confidence levels for the cold-weather placement of the mock bridge deck ($E = 33.5\text{ kJ/mol}$)	268
Figure 5-44:	Cores with water-tank S-M relationship and confidence levels for the cold-weather placement of mock bridge deck ($T_o = 0^\circ\text{C}$)	268
Figure 5-45:	Cores with water-tank S-M relationship and confidence levels for the cold-weather placement of mock bridge deck ($E = 33.5\text{ kJ/mol}$)	269
Figure 5-46:	Temperature history of 6 x 12 inch cylinders and the mock bridge deck for the warm-weather placement	271
Figure 5-47:	Temperature history of pullout cubes, 4 x 8 inch water-tank cylinders, and 28-day CIP cylinders for the warm-weather placement	272
Figure 5-48:	Temperature history of 7-day cores for warm-weather placement of mock bridge deck.....	273
Figure 5-49:	Temperature history of 28-day cores for warm-weather placement of mock bridge deck.....	274
Figure 5-50:	Concrete strength versus concrete age for warm-weather placement of mock bridge deck.....	276

Figure 5-51:	S-M relationships using the Nurse-Saul maturity function for mock bridge deck warm-weather placement ($T_o = -10\text{ }^\circ\text{C}$)	281
Figure 5-52:	S-M relationships using the Nurse-Saul maturity function for mock bridge deck warm-weather placement ($T_o = 0\text{ }^\circ\text{C}$)	281
Figure 5-53:	S-M relationships using the Arrhenius maturity function for mock bridge deck warm-weather placement ($E = 33.5\text{ kJ/mol}$)	282
Figure 5-54:	S-M relationships using the Arrhenius maturity function for mock bridge deck warm-weather placement ($E = 40\text{ kJ/mol}$)	282
Figure 5-55:	S-M relationship for the Laboratory cured cylinders with confidence levels for the warm-weather placement of the mock bridge deck ($T_o = -10\text{ }^\circ\text{C}$)	283
Figure 5-56:	S-M relationship for the Laboratory cured cylinders with confidence levels for the warm-weather placement of the mock bridge deck ($T_o = 0\text{ }^\circ\text{C}$).....	284
Figure 5-57:	S-M relationship for the Laboratory cured cylinders with confidence levels for the warm-weather placement of the mock bridge deck ($E = 33.5\text{ kJ/mol}$)	284
Figure 5-58:	S-M relationship for the Laboratory cured cylinders with confidence levels for the warm-weather placement of the mock bridge deck ($E = 40\text{ kJ/mol}$)	285
Figure 5-59:	Pullout test with laboratory S-M relationship and confidence levels for the warm-weather placement of the mock bridge deck ($T_o = 0\text{ }^\circ\text{C}$).....	287
Figure 5-60:	Pullout test with laboratory S-M relationship and confidence levels for the warm-weather placement of the mock bridge deck ($E = 33.5\text{ kJ/mol}$)	287
Figure 5-61:	Pullout test with water-tank S-M relationship and confidence levels for the warm-weather placement of mock bridge deck ($T_o = 0^\circ\text{C}$).....	288
Figure 5-62:	Pullout test with water-tank S-M relationship and confidence levels for the warm-weather placement of mock bridge deck ($E = 33.5\text{ kJ/mol}$)	288

Figure 5-63:	Cast-in-place cylinders and 4 x 8 inch cylinders with laboratory S-M relationship and confidence levels for the warm-weather placement of the mock bridge deck ($T_o = 0\text{ }^\circ\text{C}$).....	289
Figure 5-64:	Cast-in-place cylinders and 4 x 8 inch cylinders with laboratory S-M relationship and confidence levels for the warm-weather placement of the mock bridge deck ($E = 33.5\text{ kJ/mol}$)	289
Figure 5-65:	Cast-in-place cylinders and 4 x 8 inch cylinders with water-tank S-M relationship and confidence levels for the warm-weather placement of mock bridge deck ($T_o = 0^\circ\text{C}$).....	290
Figure 5-66:	Cast-in-place cylinders and 4 x 8 inch cylinders with water-tank S-M relationship and confidence levels for the warm-weather placement of mock bridge deck ($E = 33.5\text{ kJ/mol}$)	290
Figure 5-67:	Cores with laboratory S-M relationship and confidence levels for the warm-weather placement of the mock bridge deck ($T_o = 0\text{ }^\circ\text{C}$)	291
Figure 5-68:	Cores with laboratory S-M relationship and confidence levels for the warm-weather placement of the mock bridge deck ($E = 33.5\text{ kJ/mol}$)...	291
Figure 5-69:	Cores with water-tank S-M relationship and confidence levels for the warm-weather placement of mock bridge deck ($T_o = 0^\circ\text{C}$)	292
Figure 5-70:	Cores with water-tank S-M relationship and confidence levels for the warm-weather placement of mock bridge deck ($E = 33.5\text{ kJ/mol}$).....	292
Figure 5-71:	Temperature history of I-85 Sample A with corresponding bridge deck temperatures	295
Figure 5-72:	Temperature history of I-85 Sample B with corresponding bridge deck temperatures	296
Figure 5-73:	Temperature history of I-85 Sample C with corresponding bridge deck temperatures	296
Figure 5-74:	Temperature history of I-85 Sample D with corresponding bridge deck temperatures	297
Figure 5-75:	Temperature history of Creek Bridge Sample A with corresponding bridge deck temperatures	297
Figure 5-76:	Temperature history of Creek Bridge Sample B with corresponding bridge deck temperatures	298

Figure 5-77:	Temperature history of Creek Bridge Sample C with corresponding bridge deck temperatures	298
Figure 5-78:	Temperature history of Location 1 (Mid-depth) and Location 2 (Mid-depth) from the Creek Bridge deck	299
Figure 5-79:	Temperature history of Location 6 (Bottom) and Location 6S (Bottom) from the I-85 Bridge.....	300
Figure 5-80:	The S-M relationship using the Nurse-Saul maturity function for I-85 and Creek Bridge decks ($T_o = -10\text{ }^\circ\text{C}$).....	303
Figure 5-81:	The S-M relationship using the Nurse-Saul maturity function for I-85 and Creek Bridge decks ($T_o = 0\text{ }^\circ\text{C}$)	303
Figure 5-82:	The S-M relationship using the Arrhenius maturity function for I-85 and Creek Bridge decks ($E = 33.5\text{ kJ/mol}$).....	304
Figure 5-83:	The S-M relationship using the Arrhenius maturity function for I-85 and Creek Bridge decks ($E = 40\text{ kJ/mol}$).....	304
Figure 5-84:	I-85 Bridge S-M relationship with confidence levels and verification test results ($T_o = -10\text{ }^\circ\text{C}$)	305
Figure 5-85:	I-85 Bridge S-M relationship with confidence levels and verification test results ($T_o = 0\text{ }^\circ\text{C}$).....	306
Figure 5-86:	I-85 Bridge S-M relationship with confidence levels and verification test results ($E = 33.5\text{ kJ/mol}$)	306
Figure 5-87:	I-85 Bridge S-M relationship with confidence levels and verification test results ($E = 40\text{ kJ/mol}$)	307
Figure 5-88:	I-85 Bridge deck strength development using Nurse-Saul maturity function with $T_o = -10\text{ }^\circ\text{C}$	308
Figure 5-89:	I-85 Bridge deck strength development using Nurse-Saul maturity function with $T_o = 0\text{ }^\circ\text{C}$	309
Figure 5-90:	I-85 Bridge deck strength development using Arrhenius maturity function with $E = 33.5\text{ kJ/mol}$	309
Figure 5-91:	I-85 Bridge deck strength development using Arrhenius maturity function with $E = 40\text{ kJ/mol}$	310

Figure 5-92:	Creek Bridge deck strength development using Nurse-Saul maturity function with $T_o = -10\text{ }^\circ\text{C}$	310
Figure 5-93:	Creek Bridge deck strength development using Nurse-Saul maturity function with $T_o = 0\text{ }^\circ\text{C}$	311
Figure 5-94:	Creek Bridge deck strength development using Arrhenius maturity function with $E = 33.5\text{ kJ/mol}$	311
Figure 5-95:	Creek Bridge deck strength development using Arrhenius maturity function with $E = 40\text{ kJ/mol}$	312
Figure 5-96:	45°-line graph for estimated cylinder strengths from the laboratory S-M relationship using the Nurse-Saul maturity function ($T_o = -10\text{ }^\circ\text{C}$)	317
Figure 5-97:	45°-line graph for estimated cylinder strengths from the laboratory S-M relationship using the Nurse-Saul maturity function ($T_o = 0\text{ }^\circ\text{C}$).....	317
Figure 5-98:	45°-line graph for estimated cylinder strengths from the laboratory S-M relationship using the Arrhenius maturity function ($E = 33.5\text{ kJ/mol}$)	318
Figure 5-99:	45°-line graph for estimated cylinder strengths from the laboratory S-M relationship using the Arrhenius maturity function ($E = 40\text{ kJ/mol}$)	318
Figure 5-100:	45°-line graph for estimating the strength of water-tank-cured 4 x 8 inch cylinder from the mock bridge deck laboratory S-M relationships using the Nurse-Saul maturity function ($T_o = 0\text{ }^\circ\text{C}$)	324
Figure 5-101:	45°-line graph for estimating the strength of water-tank-cured 4 x 8 inch cylinder from the mock bridge deck laboratory S-M relationships using the Arrhenius maturity function ($E = 33.5\text{ kJ/mol}$).....	324
Figure 5-102:	45°-line graph for estimating the strength of water-tank-cured 4 x 8 inch cylinder from the mock bridge deck water-tank S-M relationships using the Nurse-Saul maturity function ($T_o = 0\text{ }^\circ\text{C}$)	327
Figure 5-103:	45°-line graph for estimating the strength of water-tank-cured 4 x 8 inch cylinder from the mock bridge deck water-tank S-M relationships using the Arrhenius maturity function ($E = 33.5\text{ kJ/mol}$).....	327

Figure 5-104:	45°-line graph to evaluate the pullout table using estimated strength from water-tank S-M relationship using the Nurse-Saul maturity function ($T_o = 0\text{ }^{\circ}\text{C}$)	330
Figure 5-105:	45°-line graph to evaluate the pullout table using estimated strength from water-tank S-M relationship using the Arrhenius maturity function ($E = 40\text{ kJ/mol}$)	330
Figure 5-106:	45°-line graph for estimating the strength of pullout test on the mock bridge deck using laboratory S-M relationship with Nurse-Saul maturity function ($T_o = 0\text{ }^{\circ}\text{C}$).....	335
Figure 5-107:	45°-line graph for estimating the strength of pullout test on the mock bridge deck using laboratory S-M relationship with Arrhenius maturity function ($E = 33.5\text{ kJ/mol}$)	335
Figure 5-108:	45°-line graph for estimating the strength of pullout test on the mock bridge deck using water-tank S-M relationship with Nurse-Saul maturity function ($T_o = 0\text{ }^{\circ}\text{C}$).....	341
Figure 5-109:	45°-line graph for estimating the strength of pullout test on the mock bridge deck using water-tank S-M relationship with Arrhenius maturity function ($E = 33.5\text{ kJ/mol}$)	341
Figure 5-110:	45°-line graph for estimating the strength of CIP cylinders on the mock bridge deck using Laboratory S-M relationship with Nurse-Saul maturity function ($T_o = 0\text{ }^{\circ}\text{C}$).....	346
Figure 5-111:	45°-line graph for estimating the strength of CIP cylinders on the mock bridge deck using Laboratory S-M relationship with Arrhenius maturity function ($E = 33.5\text{ kJ/mol}$)	346
Figure 5-112:	45°-line graph for estimating the strength of CIP cylinders on the mock bridge deck using water-tank S-M relationship with Nurse-Saul maturity function ($T_o = 0\text{ }^{\circ}\text{C}$).....	349
Figure 5-113:	45°-line graph for estimating the strength of CIP cylinders on the mock bridge deck using water-tank S-M relationship with Arrhenius maturity function ($E = 33.5\text{ kJ/mol}$)	349
Figure 5-114:	45°-line graph for estimating the strength of cores for the mock bridge deck using laboratory S-M relationship with Nurse-Saul maturity function ($T_o = 0\text{ }^{\circ}\text{C}$).....	353

Figure 5-115: 45°-line graph for estimating the strength of cores for the mock bridge deck using laboratory S-M relationship with Arrhenius maturity function ($E = 33.5$ kJ/mol)	353
Figure 5-116: 45°-line graph for estimating the strength of cores for the mock bridge deck using water-tank S-M relationship with Nurse-Saul maturity function ($T_o = 0$ °C).....	356
Figure 5-117: 45°-line graph for estimating the strength of cores for the mock bridge deck using water-tank S-M relationship with Arrhenius maturity function ($E = 33.5$ kJ/mol)	356
Figure 5-118: Compression strength of the pullout test and CIP Cylinder versus the cores for the cold-weather placement 7- and 28-day testing ages	358
Figure 5-119: Compression strength of the pullout test and CIP Cylinder versus the cores for the warm-weather placement 7- and 28-day testing ages	359
Figure 5-120: 45°-line graph for estimating the strength of the Creek A cylinders using I-85 Bridge S-M relationship with Nurse-Saul maturity function ($T_o = -10$ °C).....	364
Figure 5-121: 45°-line graph for estimating the strength of the Creek A cylinders using I-85 Bridge S-M relationship with Nurse-Saul maturity function ($T_o = 0$ °C)	364
Figure 5-122: 45°-line graph for estimating the strength of the Creek A cylinders using I-85 Bridge S-M relationship with Arrhenius maturity function ($E = 33.5$ kJ/mol).....	365
Figure 5-123: 45°-line graph for estimating the strength of the Creek A cylinders using I-85 Bridge S-M relationship with Arrhenius maturity function ($E = 40$ kJ/mol)	365
Figure 5-124: 45°-line graph for estimating the strength of the verification cylinders using I-85 Bridge S-M relationship with Nurse-Saul maturity function ($T_o = 0$ °C)	368
Figure 5-125: 45°-line graph for estimating the strength of the verification cylinders using I-85 Bridge S-M relationship with Arrhenius maturity function ($E = 33.5$ kJ/mol)	369
Figure 5-126: 2,400-psi verification test percent errors for best-fit I-85 Bridge S-M relationship.....	370

Figure 5-127:	7-day verification test percent errors for the best-fit I-85 Bridge S-M relationship.....	371
Figure 5-128:	Evaluation of the testing ages for the cold-weather placement of the bridge deck field project	373
Figure 5-129:	Evaluation of the testing ages for the warm-weather placement of the bridge deck field project	374
Figure 5-130:	2,400-psi verification test percent errors for I-85 Bridge S-M relationship using a 50% confidence level at 10% defect level.....	377
Figure 5-131:	7-day verification test percent errors for the I-85 Bridge S-M relationship using a 50% confidence level at 10% defect level.....	377
Figure 5-132:	Applying a confidence level and acceptance criteria to the verification test results	379
Figure 5-133:	Mid-depth concrete temperature profile for middle versus edge of the Creek Bridge pour.....	382
Figure 5-134:	Temperature profile of Location 3 of the Creek Bridge deck.....	383
Figure 5-135:	Temperature profile of Location 4 of the warm-weather placement of the mock bridge deck.....	384
Figure 6-1:	Testing ages to accurately model the strength development of concrete (Type I + 30% Class C Fly Ash)	404
Figure 6-2:	S-M relationship with confidence levels of field-cured specimens	409
Figure 6-3:	S-M relationship with 50% confidence level and 5% reduction in strength.....	411
Figure 6-4:	Suspending the maturity recording device between reinforcement bars.....	413

CHAPTER 1

INTRODUCTION

In the midst of a nationwide desire for the concrete-based road and bridge construction processes to be accelerated in order to save time and money, there is a need for a technique to help increase the speed and productivity of concrete construction. The maturity method is such a technique. Though the maturity method has been around since the 1950's, considerable advancements have made this method a practical, simple, and economical option to determine in-place strength development of concrete.

The maturity method accounts for the combined effect of the concrete temperature and concrete age on the strength development of hardening concrete. Temperature development in concrete occurs due to the hydration of cementitious materials and the impact of the surrounding environment. Through the use of a temperature-recording device, the concrete temperature is measured and recorded, which then enables the calculation of a real-time maturity index from the temperature history of the in-place concrete. The maturity index and the strength development of concrete can be related. Once this strength-maturity relationship has been established, it can then be used to estimate the in-place strength of the concrete within the structure.

By using the maturity method, the old practice of “guessing” when the in-place strength has reached the required strength can be eliminated. The in-place strength can be

estimated with confidence to allow construction processes such as form removal, application of construction loads, or the opening to traffic to be scheduled in a more efficient manner. Verification of the strength is still required but fewer cylinders are needed because the maturity method produces an accurate estimate of the time when the desired strength will be achieved. Verification strength tests can then be conducted at the times indicated by the maturity method.

In order for the maturity method to provide accurate results, improved quality control is required. The maturity method is specific to a particular concrete mixture since the heat development and strength development for each concrete mixture is unique. Therefore, any time a concrete mixture is changed, by variations in water-to-cement ratio, cement content, admixture, or aggregate source, a new strength-maturity relationship should be developed. Also, the maturity method requires that the concrete be cured and consolidated properly. If the concrete does not have an adequate supply of water for the hydration process, then the strength development will be compromised.

As of now, ASTM C 1074 (2004) is the only standard specification for the use of the maturity method. Many individual state transportation agencies are in the process of implementing, or have already implemented, specifications that allow contractors to take advantage of the maturity method. These states include Texas, Iowa, Indiana, South Dakota, Pennsylvania, and Colorado. Further discussions of different state transportation agencies specifications for the maturity method are presented in Chapter 6 of this thesis.

The maturity method has been used on multiple highway projects in various states. One of the projects that used the maturity method for strength estimation was the I-40 Bridge in Oklahoma. On May 26, 2002, a river barge collided with this bridge over

the Arkansas River, collapsing multiple spans which resulted in closing the interstate highway to traffic. The maturity method allowed an acceleration of the repairing construction schedule. Instead of the original 57 days that were scheduled for the construction process, it took only 47 days to complete (Enguis 2005a).

TxDOT has also required that the maturity method be used on the multimillion dollar “Dallas High Five” project. The intersection of I-675 and US 75, one of the most congested intersections in the nation, in Dallas is being replaced with a five-level interchange to elevate traffic. The project began on January 2, 2002, and is scheduled to be completed in April of 2007 (Enguis 2005b).

1.1 PROJECT OBJECTIVES

There were two phases in the “Evaluation of the Maturity Method to Estimate Early-Age Concrete Strength” project sponsored by ALDOT. The first phase was an evaluation of the maturity method under controlled laboratory conditions using local Alabama materials. The laboratory testing was performed to evaluate the accuracy of the maturity method for typical summer and winter temperature ranges that exist in the state of Alabama. The second phase consisted of two field studies to evaluate the accuracy of the maturity method under actual construction conditions. This report detail this second phase of this project.

The following two main objectives were considered to evaluate the accuracy of the maturity method under actual construction conditions:

1. Determine the accuracy of the maturity method for actual projects within the state of Alabama, and

2. Develop a standard specification for implementation of the maturity method for ALDOT projects.

In order to accomplish these main goals, the following secondary goals were developed:

1. Evaluate the maturity method's accuracy for estimating in-place strengths using different testing methods: pullout test, compressive testing of cast-in-place cylinders, and compressive testing of cores,
2. Determine the most appropriate curing method to develop the strength-maturity relationship,
3. Determine the effects that winter and summer construction and curing conditions have on the accuracy of the maturity method,
4. Determine the best test schedule to develop the strength-maturity relationship,
5. Find the optimum location for the placement of temperature-recording devices in structures and pavements,
6. Determine the best procedure to implement the maturity method in ALDOT projects, and
7. Review other state transportation agencies' specifications to establish advantages and disadvantages of their specifications.

1.2 RESEARCH APPROACH

Before the field study for the maturity project began, an evaluation under laboratory conditions with raw materials used in Alabama's concrete industry was conducted. These

laboratory tests provided an assessment of which maturity function and corresponding temperature sensitivity constants yield the most accurate results. Additionally, the best testing schedules for different curing temperatures were developed from these laboratory results.

In order to evaluate the maturity method for field applications, ongoing construction was used to test the maturity method. The two field projects that were utilized for this report were the fabrication of a precast prestressed girder and the construction of a reinforced concrete bridge deck. The ASTM C 1074 (2004) specification was applied to both projects, and an evaluation of the accuracy of this specification was performed. Also, several other state transportation agencies' specifications were evaluated during the two field project studies to determine the accuracy obtained from these specifications.

Along with the ASTM-required laboratory-cured specimens used to develop the strength-maturity relationship, two other field curing methods were used to determine if a field-curing method could produce more accurate strength-maturity relationship for estimating the in-place strength than those of a laboratory-curing method. In-place tests were also conducted to evaluate the accuracy of the maturity method for freshly placed concrete in a structure. To determine the ideal locations for the temperatures sensors, many sensors were embedded to monitor the temperature profile of the members for both projects.

The first project conducted was the precast prestressed girder fabrication. With cooperation from the Sherman Prestress Plant in Pelham, Alabama, the field project was conducted on the steam-curing beds in their facility. Three different curing methods were

tested on molded cylinders used to develop the strength-maturity relationship: laboratory curing and two field curing methods (lime-saturated water-tank and damp-sand-pit). A mock girder was produced so that in-place testing could be conducted without damaging an actual girder. In-place testing conducted on the mock girder included the pullout test and compressive testing of cores extracted from the mock girder. Several temperature sensors were placed throughout the length of the girder to capture the concrete's temperature and maturity development. Testing on the mock girder and molded specimens lasted for 28 days after the concrete placement.

After the prestressed girder project was concluded, the bridge deck project was conducted with the assistance of the Scott Bridge Company on the I-85 and US 29 interchange in Auburn, Alabama. Two phases existed for the bridge deck project. The first phase was similar to the precast prestressed project in which mock bridge decks were constructed and in-place tests were conducted. The in-place testing conducted on the mock bridge decks consisted of pullout tests, compressive testing of cast-in-place cylinders, and compressive testing of cores. Two cylinder curing methods were used: laboratory-cured specimens and field-cured specimens cured in a lime-saturated water-tank. The mock deck phase was conducted twice, once in the winter and once in the summer, to evaluate the maturity method's accuracy during various construction seasons. Testing on the mock bridge decks were conducted for 28 days after casting.

The second phase of the bridge deck project was to evaluate how the use of molded cylinders for verification testing would work on a construction site. In this phase the concrete used to construct the actual bridge deck was tested. Temperature sensors

were placed throughout the structure to determine the best location for the sensors. No in-place testing was conducted on the actual bridge deck.

Once the field testing was completed, analysis of the data from the different projects was conducted to determine the accuracy of the maturity method under field conditions. An evaluation of other states' specification was also conducted. Finally, a proposed specification for the maturity method was created for ALDOT.

1.3 REPORT OUTLINE

The organization of the remainder this report is shown in flow chart format in Figure 1-1.

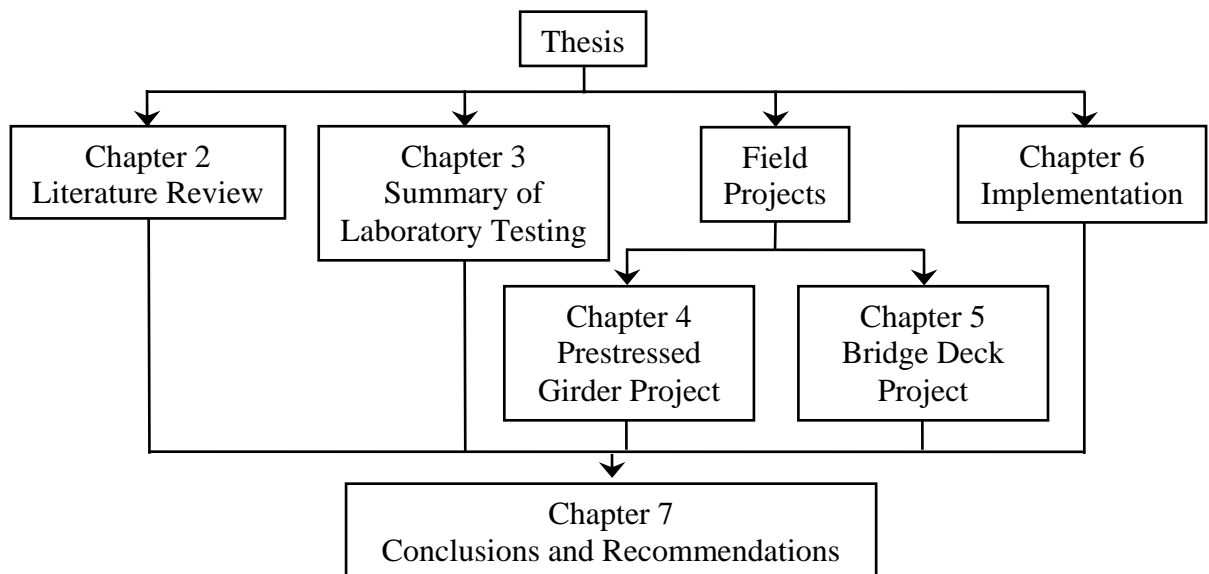

Figure 1-1: Report organization

A thorough discussion of the maturity method is presented in Chapter 2. It includes the background, different maturity functions available to calculate the maturity index, corresponding temperature sensitivity values for the different maturity functions, accuracy of the maturity method from past research, factors that affect the performance of

the maturity method, equipment used to record the concrete temperature history, and different in-place test methods.

A brief discussion of the results of the laboratory test phase (Phase I) of this project is given in Chapter 3. Included is a summary of the laboratory testing, a discussion on the accuracy of different maturity functions and the corresponding temperature sensitivity values, and a description of the testing schedules that were used for multiple curing temperature histories.

A discussion of the prestressed girder project is presented in Chapter 4. In this chapter, there is a thorough description of the testing procedures, the results from the data collected, analysis of the results, and the conclusions obtained from the prestressed girder project.

A discussion of the entire I-85 / US 29 bridge deck project is provided in Chapter 5. Descriptions of test procedures for the mock bridge decks and the tests performed on the actual bridge deck are given. The results, analysis, and conclusions for both the mock bridge deck and evaluation of molded cylinders for verification testing obtained from the I-85 / US 29 bridge project are presented.

The implementation of the maturity method is discussed in Chapter 6. Three states transportation agencies' maturity specifications are reviewed. Also included is a discussion of specification requirements to ensure that accurate estimates of the in-place strength are obtained. An outline of a proposed ALDOT Specification is also provided.

Conclusions and recommendations for the maturity method that address the project objectives are presented in Chapter 7.

Appendix A contains the pullout force and compressive strength correlation table as provided by Germann Instruments for the Lok-Test. Appendix B presents all the test data that were obtained from the Sherman Prestress Plant with pictures showing the entire process and diagrams of the mock girder. Appendix C presents all the test data that were obtained from the I-85 / US 29 bridge project and pictures of both test phases of that project. Appendix D is devoted to the proposed maturity method specification developed for the Alabama Department of Transportation. Appendix E contains the Texas Department of Transportation maturity specification Tex-426-A. Appendix F contains the Iowa Department of Transportation maturity specification IM 383. Appendix G contains the Indiana Department of Transportation maturity specification ITM 402-04T.

CHAPTER 2

LITERATURE REVIEW

2.1 INTRODUCTION

The maturity method is a simple and effective way to estimate early-age concrete strengths that are associated with bridge deck pours, prestressed girder productions, and concrete pavement applications. The maturity concept was developed in England during the 1950's when researchers were examining the effects of time and temperature on the strength development of hardening concrete. It has now become a widely used theory for estimating early-age concrete strength. Today the maturity method is used throughout the United States and the world. State transportation agencies such as Texas, Iowa, Indiana, Pennsylvania, Colorado, and South Dakota are all developing or implementing their own specifications for using the maturity method.

The purpose of this chapter is to explain the history and effectiveness of the maturity method. This chapter will outline the background of the maturity method and discuss and compare the two leading forms to compute maturity. The inherent limitations of the maturity method will be discussed along with the application of the maturity method to estimate concrete strengths. To assess the accuracy of the maturity method for estimating concrete strength, in-place testing methods were examined. Details of

the development and evaluation of strength-maturity relationships are given throughout this chapter.

2.2 DEFINITION AND DEVELOPMENT OF THE MATURITY METHOD

The strength gain of a concrete mixture is a function of its age and temperature history as long as the concrete is properly placed, consolidated, and cured (Carino 1991). The effects of temperature during the early ages of the concrete curing process have an important impact on the strength development of the concrete. Therefore, it can be difficult to estimate the in-place strength development of the concrete from strength data collected from specimens cured under a constant condition (Carino 1991). Consequently, the need for an estimate of the in-place strength of concrete using the time and temperature history of the concrete is essential. This method is known as the maturity method.

Maturity is “the extent of the development of a property of a cementitious mixture” (ASTM C 1074 2004). In other words, maturity is the development of the physical properties of the concrete as the hydration process progresses. To quantify a value for maturity, multiple functions exist to calculate the “maturity index” of the concrete. The two maturity functions that are recommended by ASTM C 1074 (2004) are the Nurse-Saul maturity function and the Arrhenius maturity function. The maturity index is “an indicator of maturity that is calculated from the temperature history of the cementitious mixture by using a maturity function” (ASTM C 1074 2004). For the case of this thesis, maturity of the concrete will be used with the strength development in order

to develop a strength-maturity relationship for a particular concrete mixture. Saul (1951) wrote the “maturity rule,” stating that:

Concrete of the same mix at the same maturity (reckoned in temperature time) has approximately the same strength whatever combination of temperature and time go to make up that maturity.

The concept of the maturity method can be used to quantify the strength development of a particular concrete mixture. Therefore, if the concrete is cured in either cold or hot conditions, the maturity should be the same and the strength of the concrete can be estimated accurately. An illustration of the maturity method for concrete cured at cold and hot temperatures is shown in Figure 2-1. If the curing temperatures are cold, then the time to reach a designated maturity will be longer than if the curing temperatures are hot. As long as the same maturity is reached for both curing conditions, their strength should be the same, as shown in Figure 2-1.

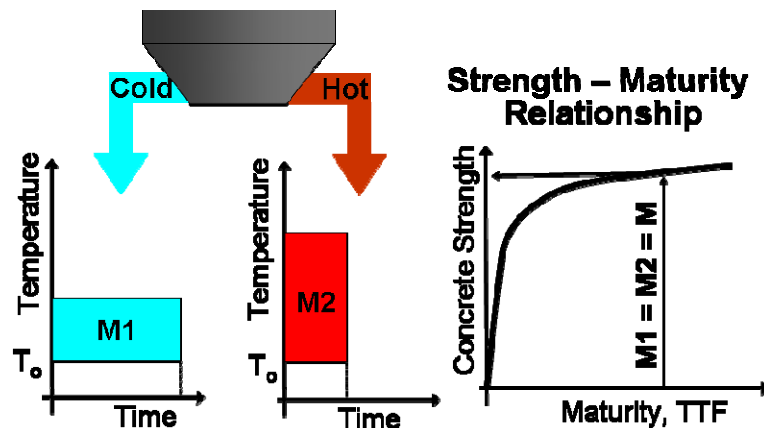

Figure 2-1: Diagram showing the effect of temperature histories on maturity calculation

In order to develop the strength-maturity relationship, multiple tasks must be conducted simultaneously on the concrete mixture. First, testing to evaluate the strength development and temperature history of a concrete mixture must be performed. To do this, multiple specimens are cast and then strength-tested at various ages. Also, the temperature is recorded by installing a recording device when the concrete is still in a fluid state. Strength testing can be conducted using multiple test methods. The two common testing methods are compression testing of molded concrete cylinders and flexural beams. When strength testing is being conducted, the maturity of the concrete must be recorded. To record the maturity of the concrete, the temperature data must be retrieved and the maturity index calculated for the time when the strength test was performed. After all the strength data have been collected and the maturity index has been calculated for each testing age of the concrete, the strength-maturity relationship can be developed using the data and a computer.

2.2.2 NURSE-SAUL MATURITY FUNCTION (NSM FUNCTION)

McIntosh (1949) first noted the idea that the rate of concrete strength gain is a function of time and temperature. He found that by using the temperature history of the concrete, the product of time and temperature above a no-hardening temperature (datum temperature) could adequately describe the strength development of concrete. However, he found that at different curing temperatures, this method did not hold true. Therefore, a more complex model than the product of temperature and time of the concrete should be used to characterize the strength development.

Soon after, Nurse (1949) wrote about the effects of steam curing on concrete. He cured multiple concrete mixtures at different temperatures and tested them at various time intervals. In order to compare the effects of time and temperature on the compressive strength, Nurse expressed the strengths “as a percentage of the strength after 3 days’ storage at normal temperature [18°C].” In effect, he was computing an equivalent age (discussed later in Section 2.3.1), which was not introduced until many years later. When these time-temperature “products” were plotted, they followed a general curve where the time-temperature product increased as the percent of 3-day compressive strength increased. Later, in a follow up on the findings of Nurse, Saul (1951) assigned the term “maturity” to the time-temperature product and gave it a mathematical basis. Saul also suggested the use of a “datum temperature” to calculate the maturity of the concrete as interpreted by Carino (1991). The Nurse-Saul maturity function is defined as follows (ASTM C 1074 2004):

$$M = \sum_0^t (T_c - T_o) \cdot \Delta t \quad \text{Equation 2-1}$$

- Where, M = Nurse-Saul maturity index at age t (°C • hours),
T_c = average concrete temperature during the Δt (°C),
T_o = datum temperature (°C), and
Δt = time interval (hours).

The units of the Nurse-Saul maturity function are °C • hours since it is a subtraction of the datum temperature (°C) from the concrete temperature (°C) then multiplied by the time interval (hours). The “datum temperature” is considered to be the

lowest temperature at which the concrete will not gain strength. Common values for the datum temperature are 0 °C (32 °F) and -10 °C (14 °F). A more through discussion of the datum temperature will be given in Section 2.3.2.

Bergstrom (1953) took the Nurse-Saul maturity function and showed that the maturity method can also be applied to normal concrete, and not just the steam cured concrete that Saul tested. The Nurse-Saul maturity function was found to work reasonably well for normal concrete curing temperatures. In the following years, there was much research done on the maturity method and its validity with respect to the effects that early-age curing temperatures have on the strength development.

The Nurse-Saul maturity function is the sum of the average temperature for the time interval minus the datum temperature multiplied by the time interval of interest. A schematic of the Nurse-Saul maturity function can be seen in Figure 2-2. The concrete temperature history of the concrete is shown with the curved line, whereas the Nurse-Saul maturity index for each time interval is accumulated in the shaded rectangular blocks.

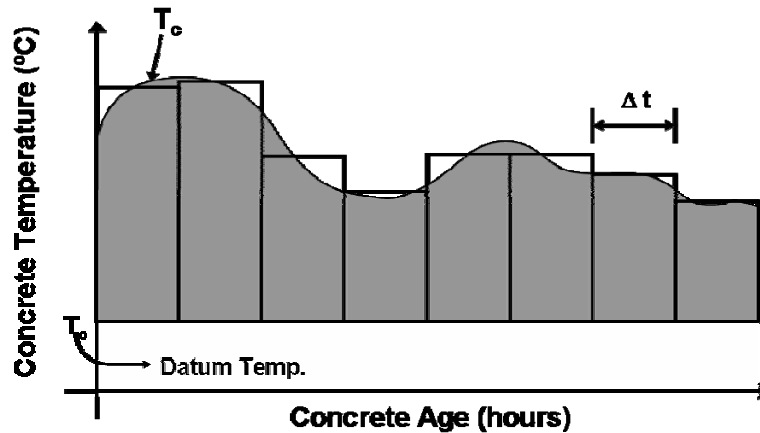

Figure 2-2: Diagram of concrete temperature over time and the Nurse-Saul maturity function

2.2.3 ARRHENIUS MATURITY FUNCTION (AM FUNCTION)

As suggested by Copeland, Kantro, and Verbeck (1962), the Arrhenius equation can be used to calculate the nonlinear rate of hydration of cement caused by the effect of temperature. Using the Arrhenius equation, Freiesleben Hansen and Pederson (1977) developed the Arrhenius maturity function, which is defined as follows:

$$M = \sum_0^t e^{\frac{-E}{R} \left[\frac{1}{273+T_c} - \frac{1}{273+T_r} \right]} \cdot \Delta t \quad \text{Equation 2-2}$$

- Where, M = Arrhenius maturity index at T_r (hours),
 T_c = average concrete temperature during Δt ($^{\circ}\text{C}$),
 T_r = reference temperature ($^{\circ}\text{C}$),
E = activation energy (J/mol), and
R = universal gas constant [8.3144 J/ (mol • K)].

Using the Arrhenius maturity function, the $^{\circ}\text{C}$ are converted to degrees Kelvin and canceled out by the units from the universal gas constant, leaving only hours. Typical values for the activation energy range from 33,500 J/mol to 45,000 J/mol. Activation energies will be discussed in Section 2.3.3. The typical reference temperature is 20 $^{\circ}\text{C}$ (68 $^{\circ}\text{F}$), but other reference temperatures, such as 23 $^{\circ}\text{C}$ (73 $^{\circ}\text{F}$), can be used (ASTM C 1074 2004).

2.2.4 USE OF THE MATURITY METHOD TO ESTIMATE STRENGTH DEVELOPMENT

Once an understanding of the calculation of the different maturity indices have been established, the strength data and the maturity indices can be used to evaluate the strength

of the concrete cured under any temperature condition. If a concrete mixture cures at different temperatures, the strength development of the concrete will be different for the different curing temperatures. Figure 2-3 shows an example of the strength versus concrete age of a Type I + 30% Class C fly ash concrete mixture cured at three different temperatures.

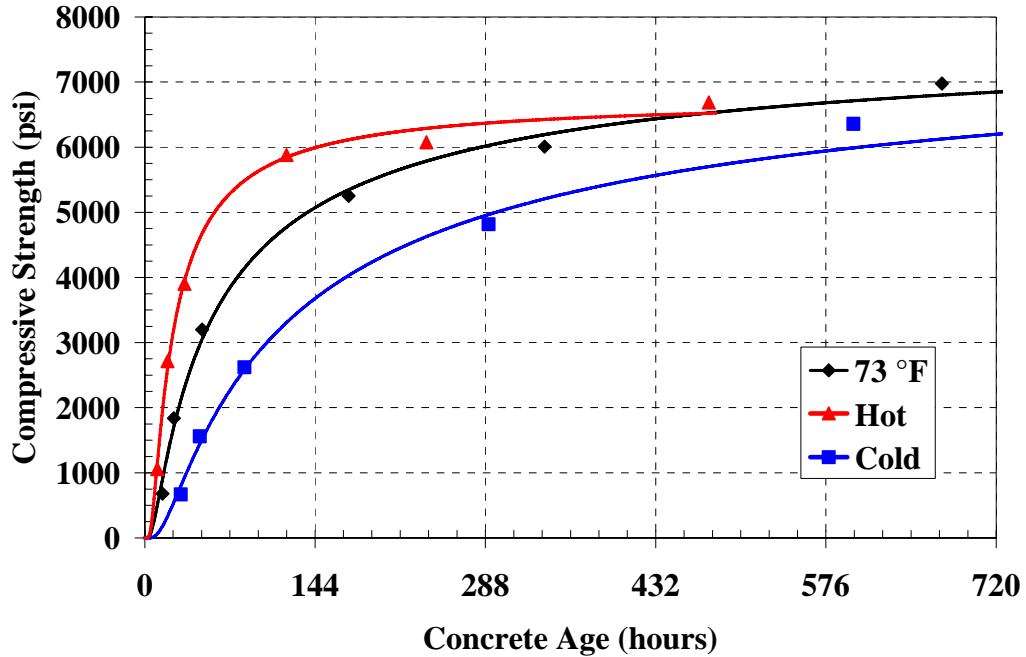

Figure 2-3: Strength versus concrete age of a concrete mixture cured at different temperatures (Type I + 30% Class C Fly Ash) (Wade 2005)

As Figure 2-3 shows, the strength gain of the same concrete mixture was different for the three curing conditions. Figure 2-4 shows the strength-maturity relationship for the same concrete mixture shown in Figure 2-3. The Nurse-Saul maturity function was used with a datum temperature of 0 °C (32 °F). The strength-maturity relationship was created from the 73 °F (23 °C) strength and maturity data (the calculations used to develop the strength-maturity relationship are discussed in Section 2.4). After the

strength-maturity relationship was created, the strength data and corresponding maturity indices for the three different curing temperatures were added to the strength-maturity relationship to illustrate that the maturity method is the same regardless of the curing temperature.

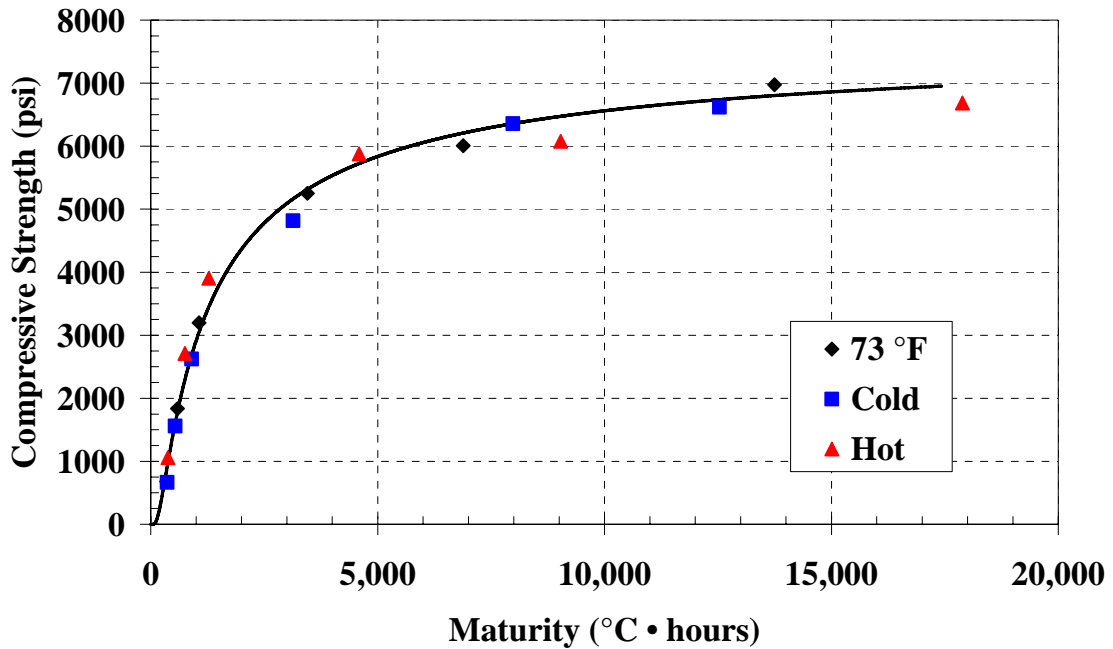

Figure 2-4: Strength-maturity relationship using the NSM function for Figure 2-3 ($T_0 = 0\text{ }^\circ\text{C}$)

Figure 2-4 shows that the maturity method accounts for the effect of curing temperatures on the strength development of this particular concrete mixture. With the knowledge of the strength-maturity relationship, the in-place strength can be estimated as long as the temperature history of the concrete in the structure is recorded.

2.3 COMPARISON OF THE MATURITY FUNCTIONS

Before the two maturity functions can be evaluated, a common factor must be established between the two functions so that their behavior can be compared. This is done by

converting the maturity functions into an “Age Conversion Factor.” The major determinant for using the age conversion factor is that the two maturity functions produce maturity values with different units. The age conversion factor allows the two maturity functions to be compared by evaluating their results with a unit-less factor. The effects of the different datum temperatures on the age conversion factor were evaluated for the Nurse-Saul maturity function, along with the effects of different activation energies on the age conversion factor for the Arrhenius Maturity function.

2.3.1 AGE CONVERSION FACTOR

It is often useful to express the maturity of a curing history in terms of a reference temperature, known as the “Age Conversion Factor.” The age conversion factor (α) is used to compare different curing temperatures and different maturity functions at a specified reference temperature. Rastrop (1954) first introduced the concept of equivalent age maturity. This can be rewritten as:

$$t_e = \sum \alpha \cdot \Delta t \quad \text{Equation 2-3}$$

Where, t_e = equivalent age (hours), and
 α = age conversion factor.

The α for the Nurse-Saul maturity function can be defined as follows (Carino 1991):

$$\alpha = \frac{(T_c - T_o)}{(T_r - T_o)} \quad \text{Equation 2-4}$$

Where, T_r = the reference temperature (°C).

The α for the Arrhenius maturity function developed by Freiesleben Hansen and Pederson (1977) can be defined as follows (Carino 1991):

$$\alpha = e^{\frac{-E}{R} \left[\frac{1}{273+T_c} - \frac{1}{273+T_r} \right]} \quad \text{Equation 2-5}$$

If the concrete temperature is equal to the reference temperature then the age conversion factor (α) is equal to one. If the concrete temperature is higher than the reference temperature, then the α is greater than one. If the concrete temperature is lower than the reference temperature, then the α is less than one.

The age conversion factors from three different datum temperatures were calculated to compare the effects of various datum temperatures on the Nurse-Saul maturity function. The datum temperatures that were evaluated were -10 °C, 0 °C, and 10 °C (14 °F, 32 °F, and 50 °F). These α results are plotted in Figure 2-5. Along with the α for the datum temperature, the α for the strength data with two different water-to-cement ratios (w/c) from Carino (1984) were added to Figure 2-5 to show the comparison of the datum temperatures with respect to actual concrete strength data.

As the temperature decreases below the reference temperature of 23 °C (73 °F), the datum temperature of 0 °C (32 °F) tends to fit the data set reasonably well. However, at temperatures higher than the reference temperature, the datum temperature 0 °C (32 °F) underestimates the age conversion factors for the actual data set. For temperatures higher than the reference temperature, the datum temperature 10 °C (50 °F) is closest to the actual data set but significantly underestimates the actual data set for temperatures less than the reference temperature. For the datum temperature of -10 °C (14 °F), the

actual data set is overestimated for temperatures less than the reference temperature and underestimated for temperatures over the reference temperature. In addition, Figure 2-5 illustrates that the age-conversion factor computed with the Nurse-Saul maturity function is linear relative to the curing temperature. It is important to note that all of the trends just described are for the particular concrete mixture that was presented by Carino (1984). These datum temperatures may not be accurate for other concrete mixtures.

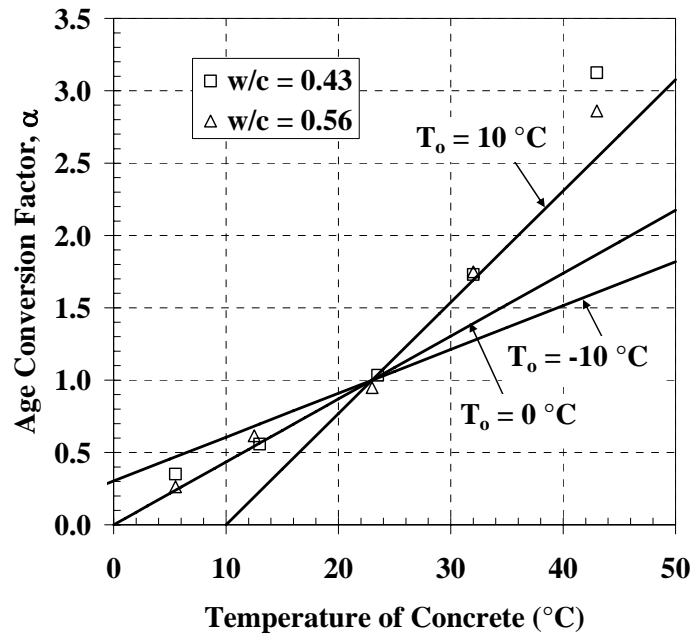

Figure 2-5: Effect of datum temperatures on the age conversion factor determined with the NSM function (Carino 1984)

As stated by Tank and Carino (1991), the Nurse-Saul maturity function was developed from empirical observations, and when a concrete mixture experiences varying early-age temperatures, the Nurse-Saul maturity method does not correctly represent the effect that temperature has on the strength development. Therefore, some researchers favor the Arrhenius maturity function because the nonlinear function accounts for the

nonlinear strength development in concrete (Tank and Carino 1991; Kjellsen and Detwiller 1993).

The α for the Arrhenius maturity function with different activation energies, along with the strength data from Carino (1984), are shown in Figure 2-6. Activation energies of 30, 40, and 50 kJ/mol were evaluated to illustrate the general trend of different activation energies. The general shape of α for the Arrhenius maturity function tends to follow the shape of the α for the actual data, which was not the case for the different datum temperatures used in the Nurse-Saul maturity function.

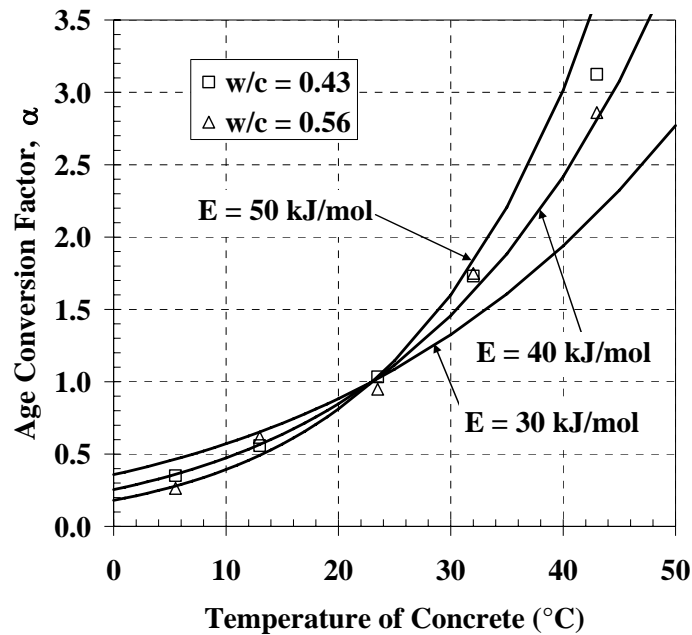

Figure 2-6: Effect of the activation energies on the age conversion factor determined with the AM function (Carino 1984)

For temperatures less than the reference temperature, the difference in α obtained for the three activation energies is minimal. When the temperature is greater than the reference temperature, the 50 kJ/mol activation energy overestimates the actual strength

data and the 30 kJ/mol underestimates the strength data. The optimum activation energy would be between 40 and 50 kJ/mol for this particular concrete mixture. Again, the trends that were explained above only apply to the concrete mixture that was presented by Carino (1984).

When α is compared for the Arrhenius and Nurse-Saul maturity functions, it can be seen that the α for the Arrhenius maturity function is the best means of modeling the nonlinear strength development of the concrete. In Figure 2-7, the α of the Arrhenius maturity function is compared to that of the Nurse-Saul maturity function. As the temperatures increases, the Nurse-Saul maturity function yields linear α values, whereas the Arrhenius maturity function yields non-linear α values.

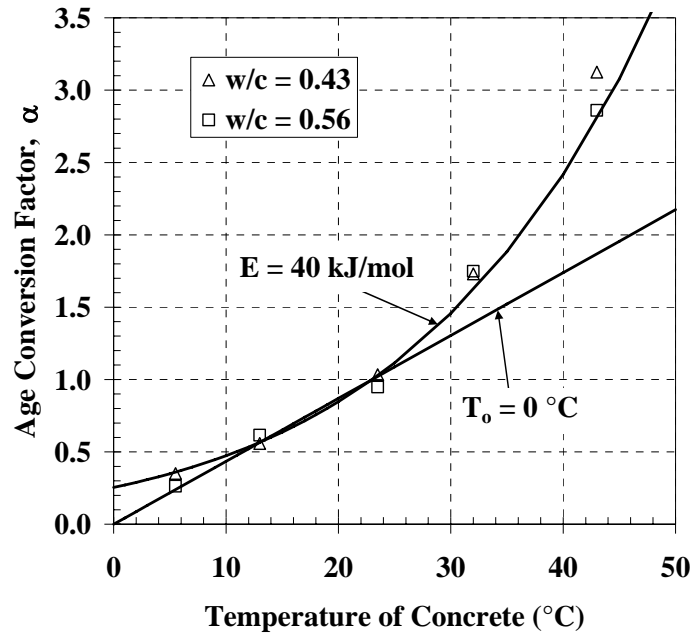

Figure 2-7: Comparing Arrhenius maturity function with $E = 40 \text{ kJ/mol}$ to Nurse-Saul maturity function with $T_0 = 0 \text{ }^{\circ}\text{C}$ ($32 \text{ }^{\circ}\text{F}$) (Carino 1984)

The percent difference in the α when using the two maturity functions and using the Nurse-Saul α as the baseline variable is shown in Figure 2-8. The Nurse-Saul maturity function with datum temperature of 0 °C (32 °F) was compared to the Arrhenius maturity function with activation energy of 40 kJ/mol. If the concrete temperature is between the reference temperature and approximately 53.6 °F (12 °C), the two α obtained from these functions are very similar. However as the temperature falls below 53.6 °F (12 °C), the percent difference in the two functions increases dramatically. For temperatures above the reference temperature, the percent difference in the two functions increases but not as dramatically as it does below 53.6 °F (12 °C). Therefore Figure 2-8 shows that the maturity functions are especially sensitive at low temperatures.

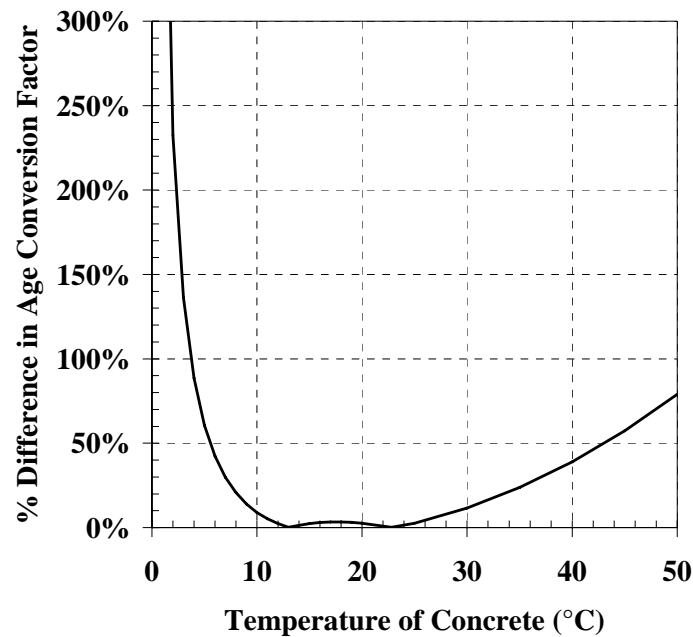

Figure 2-8: Comparing percent difference α of AM function with $E = 40$ kJ/mol to the NSM function with $T_0 = 0$ °C (32 °F)

Over the years, there has been much debate regarding which maturity function is superior for estimating concrete strengths. Many researchers believe the Arrhenius maturity function is more accurate. However, others think it is too complicated and unpractical. This group believes the Nurse-Saul maturity function is simpler and sufficiently accurate to be easily used on construction sites.

According to the results presented above, the Arrhenius maturity function is considered the preferable function to calculate the maturity for concrete because it most accurately represents the non-linear rate of hydration of the concrete. The activation energy that was considered best in the above case was only for the concrete mixture that was tested by Carino (1984). Optimum activation energies tend to change between concrete mixtures. Different datum temperatures and activation energies for different mixtures are discussed in the following sections.

2.3.2 TYPICAL DATUM TEMPERATURES VALUES

Saul (1951) explained that the datum temperature should be the lowest temperature at which concrete stops gaining strength. Saul recommended a datum temperature of -10.5 °C (13.1 °F). In a study by Plowman (1956), -12 °C (10.4 °F) was found to be the temperature at which concrete ceases to gain strength. Generally a datum temperature of -10 °C (14 °F) is used (Carino 1991). TxDOT (Tex-426-A 2004), Iowa DOT (IM 383 2004), and Indiana DOT (ITM 402-04 T 2004) all use a datum temperature of -10 °C (14 °F). ASTM C 1074 (2004) recommends a datum temperature of 0 °C (32 °F) for Type I cement without admixtures and when the curing temperature remains between 0 to 40 °C (32 to 104 °F).

Carino and Tank (1992) performed a study in which they tested concrete and mortar specimens cured under different isothermal temperatures. Specimens were made with different cementitious systems and two water-to-cement ratios. In this study, three sets of specimens were cured at 50, 73, and 104 °F (10, 32, and 40 °C) and then were strength tested at regular intervals. The best-fit datum temperatures were obtained for each concrete mixture. Table 2-1 is a summary of the datum temperature for each concrete mixture.

Table 2-1: Datum temperature values proposed by Carino and Tank (1992)

Cement Type	Datum Temperatures [°C (°F)]			
	w/c = 0.45		w/c = 0.60	
	Concrete	Mortar	Concrete	Mortar
Type I	11 (52)	11 (52)	9 (48)	7 (45)
Type II	9 (48)	9 (48)	6 (43)	5 (41)
Type III	7 (45)	6 (43)	7 (45)	6 (43)
Type I + 20% Fly Ash	-5 (23)	-2 (28)	0 (32)	3 (37)
Type I + 50% Slag	8 (46)	7 (45)	10 (50)	9 (48)
Type I + Accelerator	8 (46)	10 (50)	9 (48)	9 (48)
Type I + Retarder	5 (41)	6 (43)	5 (41)	2 (36)

From the study, Carino and Tank (1992) concluded that none of the values was -10 °C (14 °F). Most of the values that were found were greater than 0 °C (32 °F). When the w/c increased from 0.45 to 0.60 the datum temperatures tended to decrease for Type I and II mixtures. For the Type III mixtures, the datum temperatures stayed the same. As for the concrete mixtures with Type I + 20% fly ash, Type I + 50% slag, and Type I +

accelerator, the datum temperature tended to increase as the w/c ratio increased. The lowest datum temperature that was found was $-5\text{ }^{\circ}\text{C}$ ($23\text{ }^{\circ}\text{F}$) which was for the Type I + 20% fly ash concrete mixture with $w/c = 0.45$. The highest datum temperature that was found was $11\text{ }^{\circ}\text{C}$ ($52\text{ }^{\circ}\text{F}$) which was for the Type I concrete and mortar mixture with $w/c = 0.45$.

2.3.3 TYPICAL ACTIVATION ENERGY VALUES

The Arrhenius maturity function's temperature sensitivity depends on the activation energy used (Carino 1991). The activation energy can be determined in several ways: (1) it can be calculated experimentally (ASTM C 1074 2004), (2) it can be estimated from equations that incorporate the temperature of the concrete, or (3) it can be estimated from typical values. A list of values of recommended activation energies given by Carino (1991) is shown in Table 2-2. ASTM C 1074 (2004) suggests activation energies in the range of 40,000 to 45,000 J/mol for use with a Type I cement when no chemical admixtures are used. Should other cement types or admixtures be used, ASTM provides no further guidelines for the selection of appropriate activation energy values. ASTM C 1074 (2004) recommends the experimental procedure outlined in Annex A1 to determine the mixture-specific activation energy. This procedure involves the use of compression testing of mortar specimens cured at three different temperatures. The strength versus concrete age results for the three curing temperatures are used to determine the activation energy for that specific concrete mixture.

Table 2-2: Activation energy values proposed by various researchers (Carino 1991)

Cement Type	Type of Test	Activation Energy (J/mol)
Type I (Mortar)	Strength	42,000
Type I (Mortar)	Strength	44,000
Type I (Concrete)	Strength	41,000
OPC* (Paste)	Heat of Hydration	42,000 – 47,000
OPC* + 70% GGBF*	Heat of Hydration	56,000
OPC* (Paste)	Chemical Shrinkage	61,000
RHC* (Paste)	Chemical Shrinkage	57,000
OPC*(Paste)	Chemical Shrinkage	67,000
Type I/II (Paste)	Heat of Hydration	44,000
Type I/II + 50%GGBF (Paste)	Heat of Hydration	49,000

* OPC is ordinary portland cement, GGBF is ground-granulated blast-furnace slag, RHC is rapid harding concrete

The same study by Carino and Tank (1992) that was used to determine the best-fit datum temperature was also used to find the best-fit activation energies for each of the concrete mixtures evaluated. Table 2-3 summarizes the activation energy values for the Arrhenius maturity function obtained from Carino and Tank's tests. Based on these results, Carino and Tank concluded that the activation energy for a concrete mixture could be obtained from the strength-gain data of mortar cubes. From this table, it can further be seen that for some mixtures w/c had little effect on the activation energy. However, the specimens using Type I and Type II cements had significantly higher activation energies for the low water-cement ratio mixtures. The opposite was true for mixtures with Type I cement plus 50% slag; the activation energy was higher for the 0.60

water-to-cement ratio mixture. This table further indicates how the addition of admixtures can alter the activation energy. Carino (1991) recommends that calculation of the activation energy depends on the desired accuracy of the estimated strength and if precision is not as crucial, then typical values may be used with some confidence.

Table 2-3: Activation energy values proposed by Carino and Tank (1992)

Cement Type	Activation Energy (J/mol)			
	w/c = 0.45		w/c = 0.60	
	Concrete	Mortar	Concrete	Mortar
Type I	63,000	61,100	48,000	43,600
Type II	51,100	55,400	42,700	41,100
Type III	43,000	40,100	44,000	42,600
Type I + 20% Fly Ash	30,000	33,100	31,200	36,600
Type I + 50% Slag	44,700	42,700	56,000	51,300
Type I + Accelerator	44,600	54,100	50,200	52,100
Type I + Retarder	38,700	41,900	38,700	34,100

Freiesleben Hansen and Pederson (1977) recommended Equation 2-6 to calculate the activation energy depending on the temperature of the concrete:

$$T_c \geq 20 \text{ }^\circ\text{C} (68 \text{ }^\circ\text{F}): \quad E = 33,500 \text{ J/mol} \quad \text{Equation 2-6}$$

$$T_c < 20 \text{ }^\circ\text{C} (68 \text{ }^\circ\text{F}): \quad E = 33,500 + 1,470 (20 - T_c) \text{ J/mol}$$

2.3.4 SUMMARY OF THE TWO MATURITY FUNCTIONS

Some critics think the Arrhenius maturity function may be too complicated and not practical because a mixture-specific activation energy is required to obtain accurate

results. Most transportation agencies (TxDOT, Iowa DOT, and Indiana DOT) use the Nurse-Saul maturity function because it is simple and quick to implement. In addition, as long as the maturity is conservative, transportation agencies are satisfied because of the supplementary verification strength testing that some of them require. Researchers favor the Arrhenius maturity function, because it theoretically better models the non-linear strength development of concrete. However, the Nurse-Saul maturity function is generally thought to be the more practical of the two for in-the-field use.

2.4 STRENGTH-MATURITY RELATIONSHIPS

A strength-maturity relationship can be developed once the strength development of a concrete mixture has been obtained along with the corresponding maturity indices. In order to capture the strength development of a concrete mixture, strength testing must be conducted at intervals over a length of time, and ASTM C 1074 (2004) recommends ages of 1, 3, 7, 14 and 28 days for normal-strength applications. The steps for creating the strength-maturity relationship are presented in Section 2.7.1. The term “maturity” in this section refers to the maturity indices calculated by either the Nurse-Saul or the Arrhenius maturity function. When the compressive strength data are plotted versus the maturity, a unique relationship can be established that correlates the strength and maturity of the concrete mixture.

Many equations have been proposed to model the strength gain of concrete, but three are often used. These three functions are the exponential, hyperbolic, and logarithmic functions, which are defined as follows (Carino 1991):

Exponential

$$S = S_u e^{-\left[\frac{\tau}{M}\right]^\beta}$$

Equation 2-7

- Where, S = compressive strength (psi),
 S_u = limiting compressive strength (psi),
 M = maturity index (°C • hours or hours),
 τ = characteristic time constant (hours), and
 β = shape parameter.

Hyperbolic

$$S = S_u \frac{k(M - M_0)}{1 + k(M - M_0)}$$

Equation 2-8

- Where, M₀ = maturity when strength development is assumed to begin
 (°C • hours or hours), and
 k = rate constant (1/[°C • hours] or 1/hours).

Logarithmic

$$S = a + b \log(M)$$

Equation 2-9

- Where, a = constant (psi), and
 b = constant (psi/hr or psi/[°C • hr]).

Freiesleben Hansen and Pederson (1984) proposed the exponential function (Equation 2-7). The hyperbolic function (Equation 2-8) was a derivation by Carino (1991) from other researchers' hyperbolic function suggestions. ASTM C 1074 (2004) recommends the use of the hyperbolic or exponential functions. Plowman (1956) proposed the logarithmic function (Equation 2-9). Iowa DOT (IM 383 2004) and TxDOT

(Tex-426-A 2004) use the logarithmic function to develop the strength-maturity relationship.

According to Carino (1991), the logarithmic function has limitations because “the relationship predicts ever increasing strength with maturity [and] the linear relationship is not valid at very early maturities.” Carino (1991) determined that the hyperbolic function and the exponential function represented the concrete strength development very well. Freiesleben Hansen and Pederson (1984) studied the heat development of concrete and determined through empirical analyses of the data that the exponential function models the strength development of the concrete very well. The three strength-maturity relationships with data from Carino (1991) are compared in Figure 2-9.

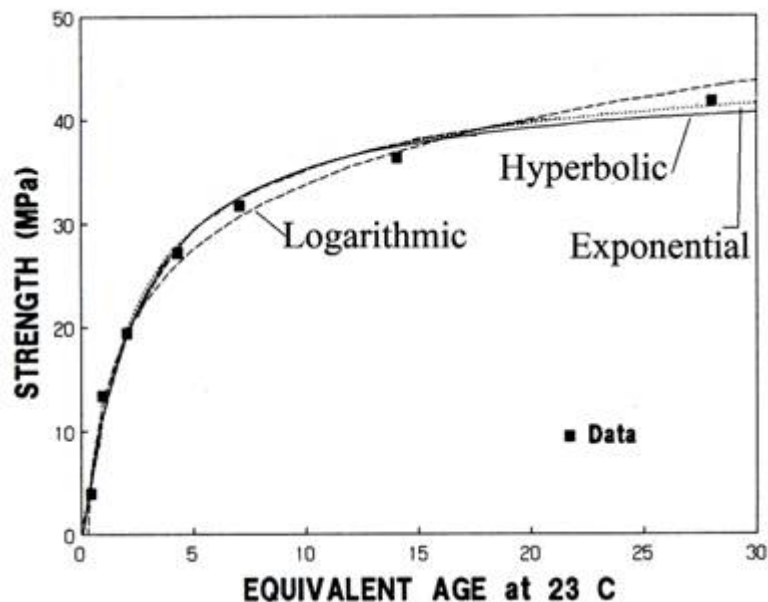

Figure 2-9: Comparison of strength-maturity relationships (Carino 1991)

From Carino’s (1991) data (with a Type I cement, $w/c = 0.45$), it appears that the exponential function and the hyperbolic function fit the data best. As for the logarithmic

function, Carino found it underestimated the early-age strengths and then began to overestimate the strength of the concrete at later ages. This equation could still be used, provided that the maturity method is only used to estimate early-age strengths.

The strength-maturity relationship can be used to estimate the in-place strength of concrete. The assumption that the strength-maturity relationship is the same for a particular concrete mixture, cured at different temperatures, allows the same strength-maturity relationship to be used in the field regardless of the temperature history of the concrete. As explained in earlier sections, the strength-maturity relationship is mixture-specific and should not be used for mixtures that are not the same as the concrete mixture that was used to create the original strength-maturity relationship.

2.5 LIMITATIONS OF THE MATURITY METHOD

A number of factors may lead to errors when estimating the in-place strength with the maturity method. A few of the factors that might cause problems with the maturity method are: the effects of curing temperature on long term strength, the fact that the strength-maturity relationships are mixture specific, the supply of moisture for hydration of the cement, and the effects of air content on the strength of concrete.

2.5.1 EFFECTS OF CURING TEMPERATURES ON LONG-TERM STRENGTH

Throughout the early years of the development of the maturity method, it was noticed that the curing temperature directly affects the long-term strength of the concrete. The effects of temperature on the long term strength has come to be known as the “cross-over effect.”

McIntosh (1956) studied the effects of different early-age temperatures on the strength gain of concrete. Carino (1991) pointed out that McIntosh's results showed that specimens exposed to high early-age temperatures tended to have higher strengths at early maturities and lower strengths at higher maturities than concrete cured at lower temperatures at early-ages. Maturities were calculated using the Nurse-Saul maturity function. Carino (1991) concluded from McIntosh's study "that a maturity function based on the product of time and temperature above a datum value cannot account for the 'quality of cure' as affected by the initial curing temperatures." In other words, the maturity method cannot account for the loss in strength that occurs due to curing at high temperatures at early ages.

Alexander and Taplin (1962) conducted a study to evaluate the strength development of concrete over a wide range of curing temperatures and ages to see if strength development obeyed the maturity rule defined by the Nurse-Saul maturity function. In agreement with earlier studies, Alexander and Taplin found that the strength-maturity relationship of concrete had a systematic deviation from the test data. The general conclusion was that at earlier ages, the Nurse-Saul maturity function greatly underestimated the strength gain of the concrete cured at higher temperatures and overestimated the strength of the concrete cured at lower temperatures. However, at later ages, the trend was opposite, as the Nurse-Saul maturity function underestimated the concrete strength when cured at lower temperatures and overestimated the concrete strength when cured at higher temperatures.

Kjellsen and Detwiller (1993) conducted a study on later-age strength prediction. They stated that the maturity method only works up to a strength level of 40 percent of

the 28-day strength. The inaccuracies they observed were due to the effects of early-age temperatures on strength. Kjellsen and Detwiller went further in trying to modify the maturity method, but the equation that was formulated is complex and difficult to apply. To date many people have attempted to develop simple ways of estimating the long-term strength of the concrete using the maturity method, but no one has been truly successful in developing a practical method.

Carino (1991) stated that an increase in initial curing temperatures would influence the behavior of the strength-maturity relationship. Figure 2-10 shows the strength development of concrete for actual concrete ages from research conducted by Carino in 1984 (Carino 1991). From this graph it is clear that the curing temperatures affected the initial rate of strength development as well as the ultimate strength of the concrete. The effects of curing temperatures on the strength-maturity relationship of concrete obtained from the data mentioned above are shown in Figure 2-11. If the strength-maturity relationship was correct, then there should not be multiple maturity curves; only one should exist.

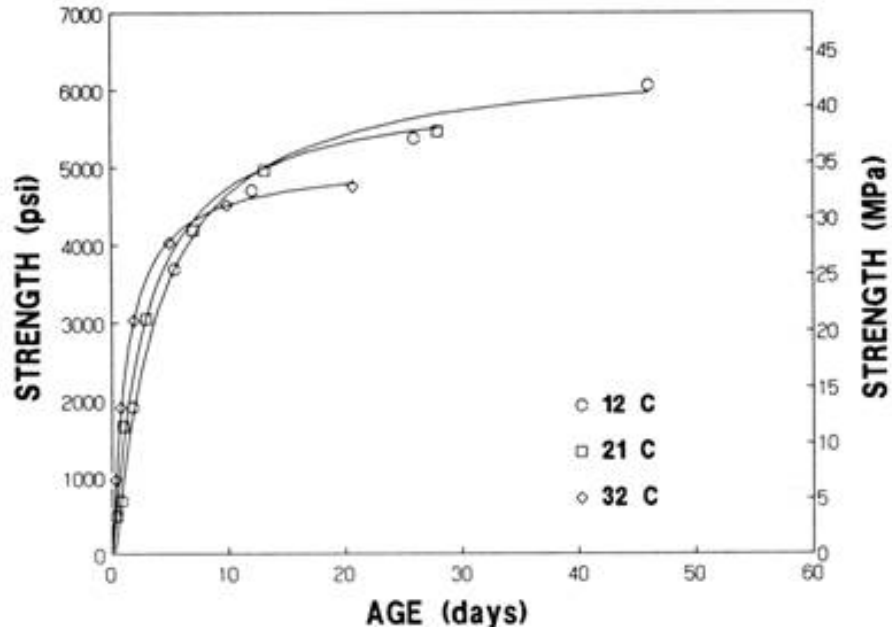

Figure 2-10: Compressive strength versus age for concrete cylinders cured at three temperatures (Type I cement, w/c = 0.55) (Carino 1991)

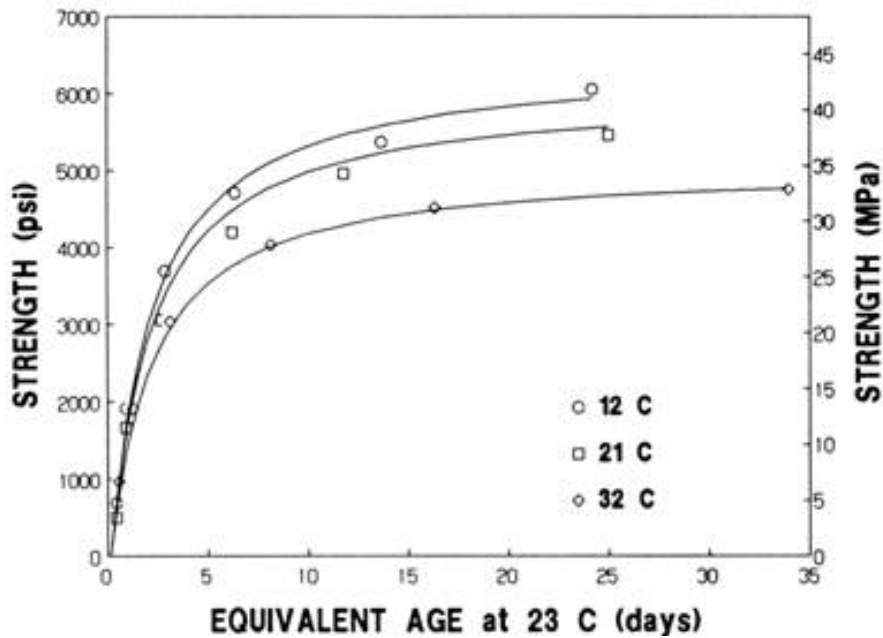

Figure 2-11: Compressive strength versus equivalent age (Carino 1991)

2.5.2 STRENGTH-MATURITY CURVES ARE MIXTURE SPECIFIC

A strength-maturity relationship must be developed for each different concrete mixture. ASTM C 1074 (2004) states that the accuracy of the strength-maturity relationship for estimating concrete strength depends on properly determining the maturity function and temperature sensitivity values of a particular concrete mixture. The strength-maturity relationship is then unique for that one particular concrete mixture (ASTM C 1074 2004). If the mixture changes, a new strength-maturity relationship must be developed. Iowa DOT's specification (IM 383 2004) requires that a new strength-maturity relationship be developed if changes in the sources of the material, proportions, or mixing equipment occur.

2.5.3 OTHER FACTORS AFFECTING STRENGTH DEVELOPMENT

Temperature affects the strength gain of concrete, but other factors have also been shown to affect the strength gain of concrete such as entrained air, clays in aggregates, and moisture. These are factors that can affect the strength-maturity relationship without the temperature ever changing.

It has been proven that as the air content increases in concrete, the concrete strength will decrease. A general rule is that for every 1% increase in total air, a 5% generally decrease in compressive strength can be expected (Mindess, Young, and Darwin 2003). This can be seen in Figure 2-12. The 28-day strengths for the different cement contents decrease as the air content of the concrete increases. The air content can become a problem with the strength-maturity relationship if the concrete supplier is not able to consistently control the air content in the concrete. When developing the strength-

maturity relationship, the air content of the concrete mixture must be the same as the air content required for the construction project.

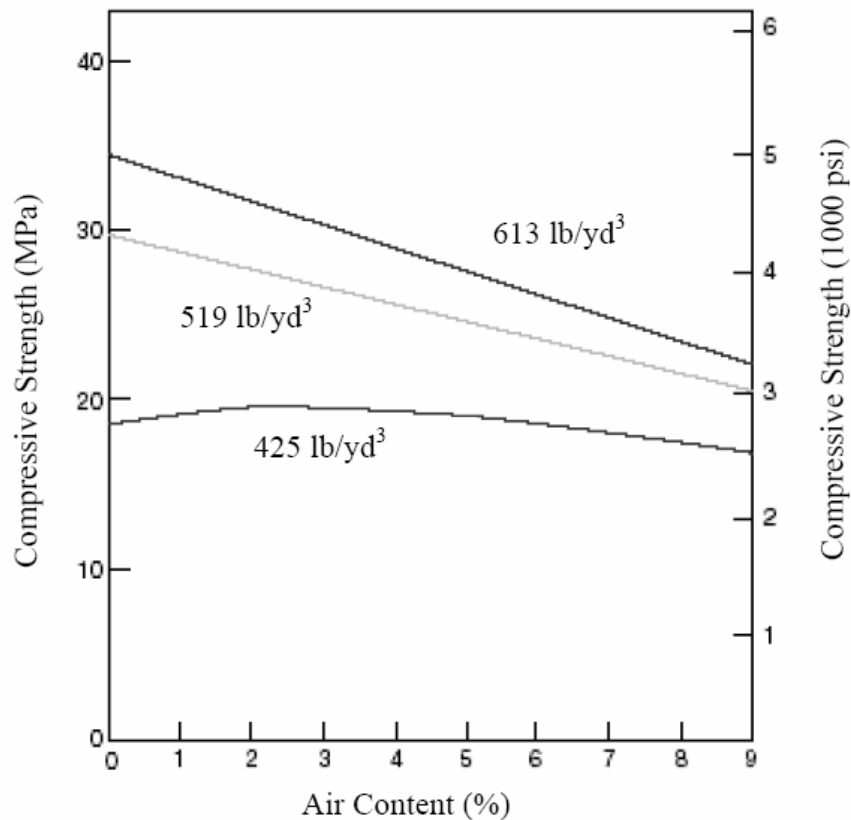

Figure 2-12: Relationship between air content and 28-day compressive strength for concrete at three cement contents. Water content was reduced with increased air content to maintain a constant slump (Cordon 1946)

Topuc and Ugurlu (2003) conducted a study on the effects of mineral filler on the properties of concrete. It was found that the existence of clay particles in aggregates has a large effect on weakening the bond between cement paste and aggregates in concrete. Throughout the study, a mineral filler was used and the results showed that the very small partials (mineral filler) were interfering with the bond between cement paste and aggregate which decreased the strength of the concrete. Therefore, if there was contamination of an aggregate stockpile with clay or other very fine minerals, concrete

being produced using these contaminated aggregates could potentially exhibit a lower strength than that produced with uncontaminated aggregate.

The maturity method uses the temperature history to estimate the in-place strength of concrete, but in order for the maturity method to be accurate, a sufficient amount of moisture must be supplied to sustain hydration while the concrete is gaining strength (Tank and Carino 1991). The ASTM C 1074 (2004) requires that a sufficient amount of water be supplied for the hydration process in order for the maturity method to be able to estimate the in-place concrete strength accurately. “If concrete dries out, strength gain ceases but the computed maturity value continues to increase with time” (Carino 1991).

During the construction process, water is lost from the paste due to evaporation or by absorption of water by the aggregates, formwork, or subgrade (Mindess, Young, and Darwin 2003). If the internal relative humidity falls below 80%, hydration will cease, the concrete strength development will be affected dramatically, and the ultimate strength will be significantly reduced. Figure 2-13 shows the effects of limited moist curing time on the strength development of concrete. The maturity method will not account for the lack of curing, and therefore the resulting strength may be much lower than what the strength-maturity relationship indicates.

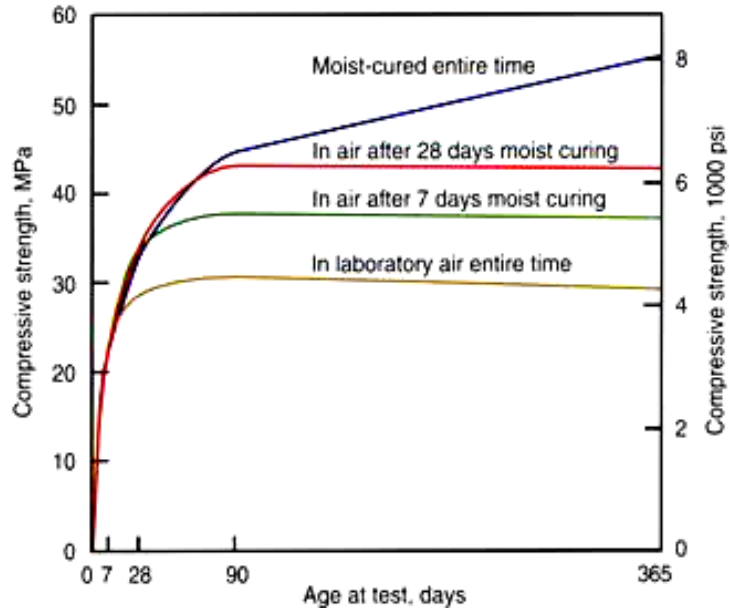

Figure 2-13: Effect of moist-curing time on strength gain of concrete (Gonnerman and Shuman 1928)

As explained, multiple factors other than temperature can affect the strength development of concrete. The temperature history of the concrete could stay the same indicating that the strength of concrete is following the strength-maturity relationship. In fact, the strength of the concrete could be significantly less. Therefore, good quality control must be in place to ensure that the strength-maturity relationship is accurate. The air content, curing methods, and stockpiles need to be monitored. With this in mind, in-place testing, along with the maturity method, can be used to ensure that adequate strength is reached. Further discussion of in-place testing can be found in Section 2.8.

2.6 MATURITY RECORDING DEVICES

Many different temperature-recording devices exist in the market today. Some are simple devices, displaying only the temperature of the concrete, while other devices can record

the temperature and time while calculating the maturity index. A simple thermometer can be used to record temperature and then the maturity index can be calculated, but this method can be inaccurate and time-consuming.

In this section, only a few maturity devices are reviewed. These maturity-recording devices all record temperature over time and were able to compute the maturity within the device or through external units used to access the data. Iowa DOT and TxDOT use a device that employs thermocouple wires attached to an external data-logging device. Two other devices were evaluated because of their simplicity and possible usefulness for ALDOT. The maturity recording devices evaluated during this research project were considered the most practical maturity recording devices at the time of the research. The devices reviewed are: (1) the System 4101 Concrete Maturity Meter distributed by Humboldt Manufacture Company; (2) intelliROCK II distributed by Nomadics Construction Labs; and (3) The COMMAND Center distributed by The Transtec Group.

2.6.1 SYSTEM 4101 CONCRETE MATURITY METER

The System 4101 Concrete Maturity Meter is a multi-channel maturity meter used, but not required, by Iowa DOT and TxDOT. Other multi-channel maturity meters exist, but the Humboldt Maturity Meter is one of the more commonly used multi-channel maturity meters. Figure 2-14 shows a picture of this system. Each maturity meter uses four type “T” thermocouple wires with quick-connect thermocouple jacks and an RS-232 cable. The RS-232 cable is used to connect the maturity meter to a computer to allow the data to be downloaded. Each maturity system has four channels. A 9-volt lithium battery

supplies power to the maturity meter and a rechargeable model is also available. Each maturity meter can be programmed with a meter ID number, time and date, and phone number. The maturity meter records data every half hour for the first two days and then every hour for the remaining time for up to 327 days. Type “T” thermocouple sensors have a temperature measuring accuracy of ± 1 °C and can record temperatures in the range of 14 °F to 194 °F (-10 °C to 90 °C).

The Humboldt maturity meter conforms to ASTM C 1074 (2004) specifications and can calculate both the Nurse-Saul and the Arrhenius maturity index. For the Nurse-Saul maturity function, the datum temperature (T_o) can be input into the maturity meter with a range of -20 °C to 60 °C. As for the Arrhenius maturity function, the constant E/R and reference temperature (T_r) can be input with ranges of 0 K to 20,000 K and 0 °C to 40 °C, respectively. The maturity meter can operate at temperatures between -4 °F and 122 °F (-20 °C and 50 °C) and is encased in a watertight, impact resistant box.



Figure 2-14: Humboldt system 4101 concrete maturity meter

The maturity index can be read directly from a display on the maturity box. The temperature history, time, and maturity can be downloaded to a computer through a COM port. Once the data have been downloaded, the time and date that recording started is available and for all four channels; the temperature-time history, Nurse-Saul maturity index, and Arrhenius maturity index can be displayed.

In order to record the temperature of the concrete, the maturity meter must be in close proximity to the area where the concrete temperature is being monitored. One end of the type “T” thermocouple wire is inserted into the concrete, while the other end, with the quick-connect jack, is plugged into the maturity meter. Once the thermocouple wire is installed in the concrete, the maturity meter is then turned on and recording started. The Humboldt maturity meter needs to be protected from environmental elements and from construction procedures so that the meter will not be destroyed.

2.6.2 INTELLIROCK II

The intelliROCK II system was considered because of the ability for the sensor to be self-contained and embedded within the concrete member. Figure 2-15 is a picture of the console and the temperature sensor used for this system. The battery and data logging chip are contained within the sensor that is embedded in the concrete. A wire runs from the embedded device to the edge of the concrete where a handheld console is connected whenever data needs to be downloaded or the maturity index needs to be read.



Figure 2-15: intelliROCK II console and sensor (Source: Engius Construction Intelligence)

Two sensors are available for recording the maturity index of the concrete: MAT-02-1H28D and MAT-02-5M7D. The MAT-02-1H28D is the standard sensor that records temperature and maturity every hour for 28 days. The MAT-02-5M7D is the high-early strength sensor which records data every 5 minutes for 7 days. If other time intervals are required, the supplier can program the sensors to accomplish that need. Each sensor can also record the job site ID and some placement notes. A data lock function is enacted on the sensor once the sensor is started to prevent any tampering with the data. The temperature accuracy is ± 1 °C. Additional data stored in the sensors are time and maturities of the maximum and minimum temperatures recorded.

Both the Nurse-Saul maturity function and Arrhenius maturity functions are calculated for this system. The maturity index is calculated every minute for an “up-to-the-minute accuracy.” Any reasonable datum temperature can be used to calculate the

Nurse-Saul maturity function and any activation energy can be used for the Arrhenius maturity function.

The console is attached to the wire through a quick-release stereo jack. The wire used to communicate with the sensor is a four-foot long, 18-gauge wire. Additional lengths up to 100 feet can be ordered. Once the sensor is installed into the concrete, the console is attached to the wire and the sensor activated. Then the console is disconnected and the sensor will continue to record the temperature. When the maturity index of the concrete is needed, the console is connected to the wire and the maturity index can be read directly from the console. If the entire temperature and maturity history is desired, the data can be transferred to the handheld console and then transferred to a computer. A computer program for reviewing the data is also provided.

2.6.3 THE COMMAND CENTER

The COMMAND center system is similar to the intelliROCK system. A sensor is placed into the concrete with a wire running to the edge of the concrete so that a pocket PC or laptop can be attached to the sensor to communicate with it. The sensor is self-powered and self-contained for recording the time and temperature of the concrete. The Transtec Group has created a computer program for a pocket PC or computer that will automatically download temperature data from the sensors and calculate the maturity index. Along with supplying the software, The Transtec Group has developed the maturity sensor using iButtons (made by Dallas Semiconductor). The connectors to connect the sensor to the pocket PC or computer are supplied. Figure 2-16 is an example of the pocket PC that can be used to connect to the maturity sensor. The COMMAND

Center uses the Nurse-Saul maturity function with any datum temperature that the user defines. The Arrhenius maturity function is not used in calculating the maturity index but the supplier indicates the possibility of creating an Arrhenius maturity index if needed.

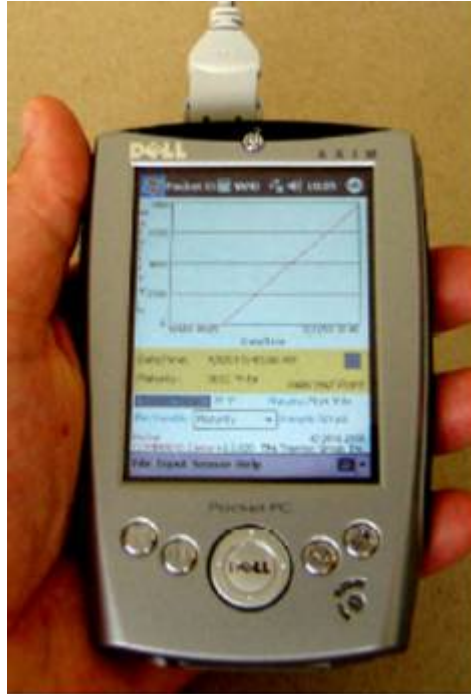

Figure 2-16: Pocket PC used with The COMMAND Center System
(Source: The Transtec Group)

The sensors that are used have an accuracy of ± 1 °C and have a temperature range of 14 °F to 185 °F (-10 °C to 85 °C). Any time interval may be programmed into the iButtons. Typical measurement intervals and monitoring periods are as follows: record every 1 minute for 34 hours, record every 5 minutes for 7 days, and record every 20 minutes for 28 days. The cable length for the sensors is typically 8 feet but can be ordered in lengths up to 100 feet. Figure 2-17 is a picture of the COMMAND Center temperature sensor.



Figure 2-17: The COMMAND Center temperature sensor

2.7 APPLICATION OF THE MATURITY METHOD

The maturity method can be used in many different concrete construction applications. For ALDOT, the maturity method can be used for form removal, opening of a concrete pavement or bridge deck to traffic, prestressed girder fabrication or other means for accelerating the construction process. When using the maturity method, two phases must be conducted: development of the strength-maturity relationship and estimation of the in-place strength.

2.7.1 DEVELOPING THE STRENGTH-MATURITY RELATIONSHIP

Before the strength-maturity relationship can be developed, several decisions need to be made. First, the maturity function and appropriate temperature sensitivity values need to be selected. Typical values of the datum temperature or activation energy can be used if a

high degree of accuracy is not required. Once the maturity function has been selected, the temperature-recording devices must be chosen.

The strength-maturity relationship should be created before the fieldwork is started. However, if this is not possible, then the strength-maturity relationship can be developed during the first day of concrete placement. Conventional means of testing the concrete strength need to be conducted for the initial few days of construction until the strength-maturity relationship has been developed.

ASTM C 1074 (2004) has some recommendations for developing the strength-maturity relationship. In accordance with ASTM C 192 (2002), 15 cylinders should be prepared from the concrete that will be used in the structure. Then, temperature sensors should be embedded in the center of at least two specimens, and the temperature sensors should start recording data immediately. The cylinders are then moist cured at 73 °F (23 °C) until they reach the testing age. Compressive tests are conducted in accordance with ASTM C 39 (2003) at the recommended ages of 1, 3, 7, 14, and 28 days. However, more testing, especially at early ages, will result in a higher accuracy when defining the strength-maturity relationship. Two specimens are to be tested at each age, and if one of the compressive strength exceeds 10% of their average strength, then another specimen should be tested. At each testing age, the maturity index is to be recorded at the time the compressive tests are conducted. ASTM C 1704 (2004) allows flexural strength testing instead of compressive testing of molded cylinders. The procedures for creating the flexural strength versus maturity relationship are similar to the procedures used for cylinders.

Once compressive testing has been conducted and maturity indices have been recorded, the strength-maturity relationship can be developed. The average compressive strengths are plotted versus their maturity indices and the best-fit curve is calculated for the data. ASTM C 1074 (2004) states that the strength-maturity relationship can either be drawn by hand or established through regression analysis by using a computer. By using a computer to determine the best-fit equation for the data, the most accurate strength-maturity relationship will be developed for that concrete mixture. An example of a strength-maturity relationship using the Nurse-Saul maturity function with a datum temperature of 0 °C (32 °F) is presented in Figure 2-18. After the strength-maturity relationship has been developed, it can be used to estimate the in-place strength of the structure, as explained in the following section.

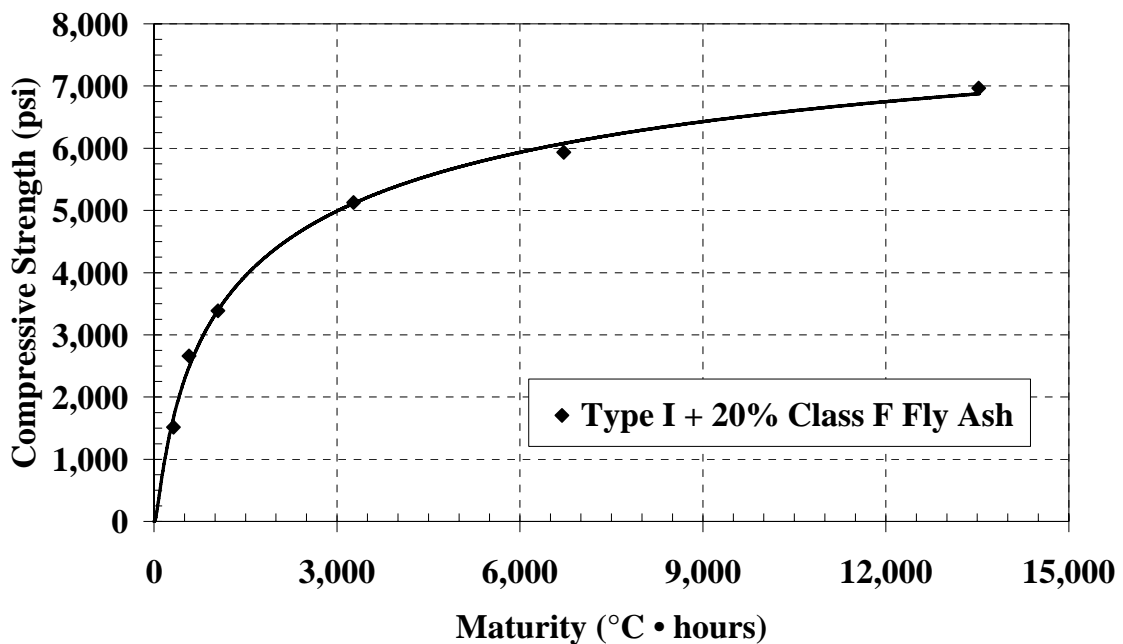

Figure 2-18: Example of a strength-maturity relationship using Nurse-Saul maturity function with $T_0 = 0$ °C

2.7.2 ESTIMATING THE IN-PLACE STRENGTH

In order to estimate the in-place strength of the concrete, maturity sensors must be installed in the fresh concrete as soon as possible. This can be done by either attaching the sensors to the form or reinforcing steel before the concrete is placed or by inserting the sensor in the fresh concrete right after the concrete is placed. Once the sensor is embedded in the concrete, the temperature recording must be started as soon as possible (ASTM C 1074 2004). Placement of the sensor in the structure depends on many factors such as critical construction operations and the location of most extreme environmental exposure. ASTM C 1074 (2004) recommends that the sensor be installed in the structure at locations “that are critical in terms of exposure conditions and structural requirements.” For example, if the maturity method was being used for a mainline paving operation, then the sensors should be placed in locations such as the beginning and end of the pavement placement for a day. By placing the sensors at these locations, the strength of the concrete can be accurately estimated and used to determine the earliest time that traffic can travel on the new concrete.

Once the sensor is placed and recording has begun, the maturity index can be calculated at any time to estimate the in-place concrete strength. ASTM C 1074 (2004) states that the same maturity function and values that were used for the strength-maturity relationship must be used in calculating the maturity index in the structure. When the strength at the location of the sensor is desired, the maturity index is to be read or calculated from the temperature history at that location. Then, using the strength-maturity relationship developed earlier, the compressive strength is estimated using the measured maturity index (ASTM C 1074 2004). An example of this process using the same

strength-maturity relationship given in Figure 2-18 is shown in Figure 2-19. The assumed maturity index in the structure is 2,400 °C • hours and the corresponding compressive strength is 4,700 psi. If the required strength at this location is 4,700 psi, then the in-place strength is assumed to be sufficient, and the construction process can continue. The Iowa DOT has accepted this method for estimating all strength in a concrete structure. On the other hand, ASTM C 1074 (2004) and TxDOT require a verification of the in-place strength for critical construction operations. More details of the verification of the in-place strength are given in the following section.

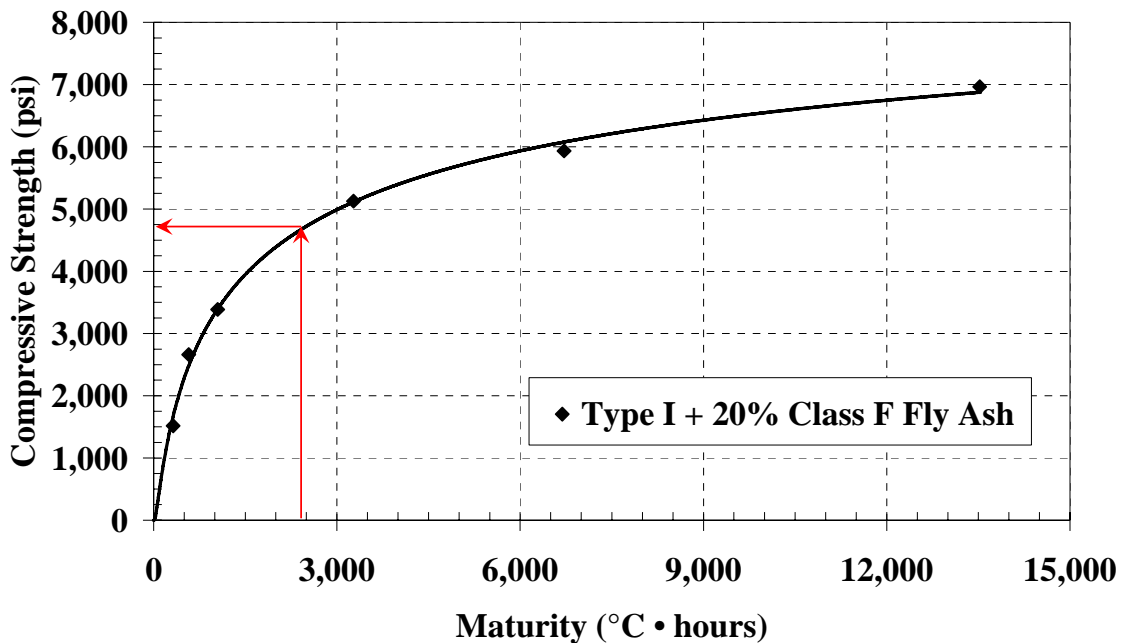

Figure 2-19: Example of estimating the in-place strength of the concrete

2.7.3 VERIFICATION OF IN-PLACE STRENGTH

ASTM C 1074 (2004) recommends that before a critical operation is conducted, other tests along with the maturity method must be conducted to verify that the concrete placed

in the structure has obtained the required strength. Other test methods to evaluate the in-place strength are:

- Pullout test (ASTM C 900 2001),
- Compressive testing of cores (ASTM C 42 or AASHTO T 24 2002),
- Compressive testing of cast-in-place cylinders (ASTM C 873 2004), and
- Penetration resistance test of hardened concrete (ASTM C 803 2003).

ASTM C 1074 (2004) also states that molded cylinders from the concrete as-delivered can be used to help verify the in-place strength. Molded cylinders are used by other DOTs as a means of verifying the in-place strength of the concrete at critical locations. TxDOT (Tex-426-A 2004) requires a set of three cylinders cast from concrete placed where the sensor is located in the structure. Thermocouple wires are embedded in two of the specimens which are then connected to a maturity meter. The cylinders are moist-cured or bath-cured according to ASTM C 192 (2002). Once the maturity meter is connected to the in-place concrete or the molded cylinders have reached or exceeded the maturity of the required strength, the cylinders are tested in accordance with ASTM C 39 (2003) to verify the estimated strength. The strength results are to be discarded if one cylinder is greater than 10% of the average of the other two cylinders or if one of the specimens is obviously defective. If two or more cylinders are discarded, a new batch must be made unless other means of verification can be made. Following the testing of the specimens, the average maturity is recorded along with the average strength. Then using the strength-maturity relationship developed earlier and the average maturity when the compression tests were performed, the average cylinder strength is estimated. If the

estimated cylinders strength and the average measured cylinder strengths are within an acceptable range, then it is assumed that the strength-maturity relationship is valid for the concrete supplied to site. Once the in-place concrete has reached or exceeded the required maturity for the required strength, the in-place concrete is assumed to have reached the required strength.

The problem with using cylinders as a means of verifying the in-place strength is that it does not provide a true representation of the in-place concrete strength. Since the cylinders are cured under different conditions than the concrete in the structure, the strength can be different because of reasons discussed in Section 2.5. Furthermore, when cylinders are made, they are consolidated in accordance to ASTM C 31 (2003), which is not the same as the consolidation of the concrete that is placed in the structure. Therefore, the cylinders may have a higher or lower compressive strength due simply to the method by which the cylinders were made.

Other tests are available that give a more accurate evaluation of the in-place strength. Some of the accepted tests include the pullout test and compressive testing of cast-in-place cylinders. With enough preplanning, these tests can be used along with the maturity method to estimate the in-place strength. The in-place test equipment is placed in the structure at critical locations along with maturity sensors. When the maturity reaches the desired value, the pullout test or cast-in-place cylinders can be tested to ensure the in-place strength is adequate. More discussion of the pullout test and cast-in-place cylinders will be provided next.

2.8 IN-PLACE STRENGTH TESTING

“The objective of in-place testing during construction is to assure, with a high degree of confidence, that the concrete in the structure is sufficiently strong to resist construction loads” (Carino 1993). The only way to assess the accuracy of the maturity method is to compare the in-place strength estimated with the maturity method to an accepted in-place strength testing method. Commonly accepted in-place test methods include: compression testing of cores, compression testing of cast-in-place cylinders, and the pullout test. Most in-place test methods are used to evaluate the strength of the concrete so that construction processes can continue. On the other hand, cores are usually only used when it is suspected that the strength of the concrete in the structure may not be adequate. Then, cores are taken and tested to ensure that the concrete strength in the structure has indeed met the strength requirements. This section will discuss the nature of in-place testing and the background and variability of these three methods.

2.8.1 NATURE OF IN-PLACE TESTING

Before discussing the three in-place testing methods, the behavior associated with in-place strengths must be understood. In the United States, the traditional method for estimating the concrete strength in a structure is done by molding and testing field-cured concrete cylinders (ACI 228.1R 2003). The strength data that are obtained from field-cured cylinders may be considerably different from the strength of the concrete in a structure due to different bleeding, consolidation, and curing conditions (Soutos, Bungey, and Long 2000).

To estimate the in-place strength using an in-place testing method, three primary sources of uncertainty must be accounted for (ACI 228.1R 2003):

1. The average value of the in-place results,
2. The relationship between compressive strength and the in-place test results,
and
3. The inherent variability of the in-place compressive strength.

Once these factors are accounted for, then in-place testing can be used to estimate the in-place compressive strength of the concrete. Along with the variability that can occur between molded cylinders and the in-place strengths, there is an inherent variability of concrete strength within the structure itself. This variability is due to “within-batch variability, systematic strength variation with member, systematic between-member variation if the structure has many members, and batch-to-batch variation if the structure contains more than one batch” (Bartlett and MacGregor 1999). Bartlett and MacGregor stated that “the variation of strength throughout a structure depends on the number of members, number of batches, and type of construction.” With this in mind, along with the knowledge that molded cylinders can be a poor representation of the in-place strength of a structure, in-place testing is an important alternative to assess the strength of the concrete in a structure.

An understanding of the design strengths for a structure and the measured strength obtained from in-place testing or acceptance testing through molded specimens is also needed. The design of structural elements is based on the specified compressive strength (f'_c). The specified compressive strength as defined by ACI 214 (1997) is the

compressive strength level that is expected to be exceeded with a 90% probability. In other words, of all the concrete that is produced for a specified value of f'_c , only 10% of the concrete strength is expected to fall below the specified strength of f'_c . The strength population for a typical concrete mixture is illustrated in Figure 2-20. Also added to Figure 2-20 is the location of f'_c and average strength (f'_{cr}) measured from testing the strength population for the concrete mixture. The AASHTO LRFD Bridge Construction Specification (2004) also states for a given mixture design that “no more than one in ten strength tests will be expected to fall below the specified strength.” There is thus a 10% probability of low strength built into the strength of the concrete for both the ACI and AASTHO design procedures.

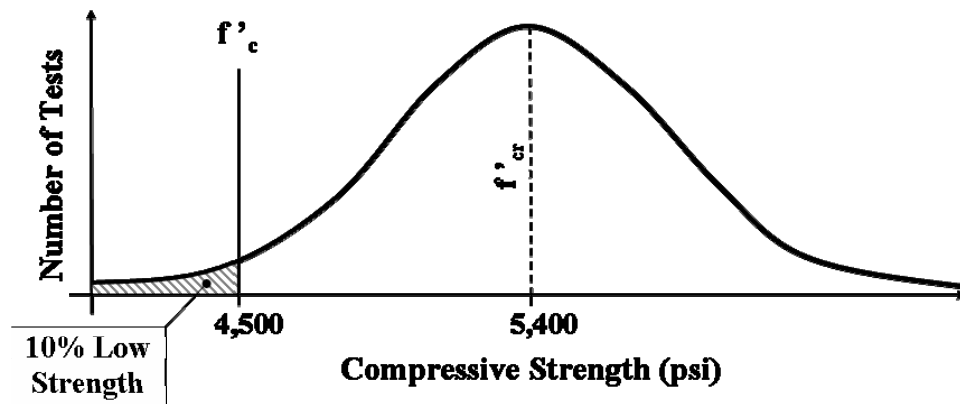

Figure 2-20: Strength for a population of concrete

When measuring the average strength (f'_{cr}) of a sample of concrete, whether using in-place or molded specimens, the average strength of the population is obtained. Therefore 50% of the measured strength values are lower than the average and 50% are higher than the average. When testing the in-place strength, the average compressive strength of the tests should be higher than f'_c to ensure 90% of the in-place concrete has a

strength higher than f'_c . In accordance with ACI 318 (2005), the strength of the concrete shall be satisfactory if the following two requirements are met:

1. Every arithmetic average of any three consecutive strength tests equals or exceeds f'_c , and
2. No individual strength test (average of two cylinders) falls below f'_c by more than 500 psi when f'_c is 5,000 psi or less; or by more than $0.10f'_c$ when f'_c is more than 5,000 psi.

ACI 318 (2005) states that if the concrete does not meet the first requirement, then steps must be taken to increase the average of subsequent strength test results. In addition, if the second requirement is not met, then a set of three cores should be taken from the area in question. If the average concrete core strength is 85% of or more than f'_c , then the area is considered structurally adequate, but no single core strength can be less than 75% of f'_c . If these requirements are not met, then extensive testing of the load capacity of the structure must be conducted or the concrete in question must be removed.

The AASHTO requirements for accepting concrete placed in a structure are stricter than the ACI requirements. In accordance with the AASTHO LRFD Bridge Construction Specification (2004), if the strength from any acceptance test falls below the specified strength, the concrete will be rejected and must be removed. For concrete that is used for footing and other non-critical elements, such as concrete rails, the concrete strength cannot fall below 500 psi below the specified strength. If strengths are less than 500 psi below the specified strength, then the concrete has to be removed unless the

strength can be verified by coring or the engineer states that the location of the concrete in question is not critical to the structural integrity of the member.

To ensure that 90% of the in-place strengths are well above the specified strength, confidence levels can be applied to the strength-maturity relationship. Vander Pol (2004) states that by using the best-fit S-M relationship it “will greatly underestimate the concrete strength for a significant fraction of concrete placements” (2004). Hindo and Bergstrom (1985) suggested the general tolerance factor, which is based on the assumption that 10% of the strength of the concrete is below f'_c . This method is also recommended by ACI 228.1R (2003). The tolerance factor method uses the probability (P) that 10% of the in-place strength will be below the specified strength based on a confidence level (γ) and the number of tests (n). Confidence levels are based on a one-sided tolerance limit for a normal distribution. Hindo and Bergstrom (1985) suggested a 75% confidence level be used for ordinary structures, a 90% confidence level be used for very important structures, and a 95% confidence level be used for nuclear power plants. The confidence level of 75% is the most commonly used value (ACI 228.1R 2003). Equation 2-10 shows how to compute the strength at a defect level of 10% at various confidence levels.

$$S_{0.10} = S(1 - C.V. \times K) \quad \text{Equation 2-10}$$

where, $S_{0.10}$ = strength for 10% defect level (psi),
S = sample average strength (psi),
K = one-sided tolerance factor, and
C.V. = coefficient of variation.

Table 2-4 gives the one-sided tolerance factor for a 10% defective level for γ values of 50%, 75%, 90%, and 95%. γ value of 50% was added to determine if a 50% confidence level would be adequate for some ordinary non-critical construction processes.

Table 2-4: One-sided tolerance factor (K) for 10% defect level (Odeh and Owen 1980)

Number of Test, n	Confidence Level, γ			
	50%	75%	90%	95%
3	1.498	2.501	4.258	6.158
4	1.419	2.134	3.187	4.163
5	1.382	1.961	2.742	3.407
6	1.360	1.860	3.494	3.006
7	1.347	1.791	2.333	2.755
8	1.337	1.740	2.219	2.582
9	1.330	1.702	2.133	2.454
10	1.324	1.671	2.065	2.355

Confidence levels are applied to the strength-maturity relationship because when a concrete supplier designs a concrete mixture, an inherent over strength is used to ensure that the majority of all the 28-day tests (acceptance age) are above the f'_c requirements. The strength-maturity relationship is also developed with the concrete that inherently includes this over-design. Confidence levels will theoretically take into account inherent over-design and develop a strength-maturity relationship based on the f'_c of the concrete. The best-fit strength-maturity relationship is in theory at a 50% confidence level with a probability of 50% defect level. Therefore, the confidence levels should be applied to the strength-maturity relationship to develop a strength-maturity relationship that incorporates a 10% defect level and a specified confidence level. An example of the

confidence levels being applied to a strength-maturity relationship and the theory of a 10% defective level for a given concrete mixture is shown in Figure 2-21.

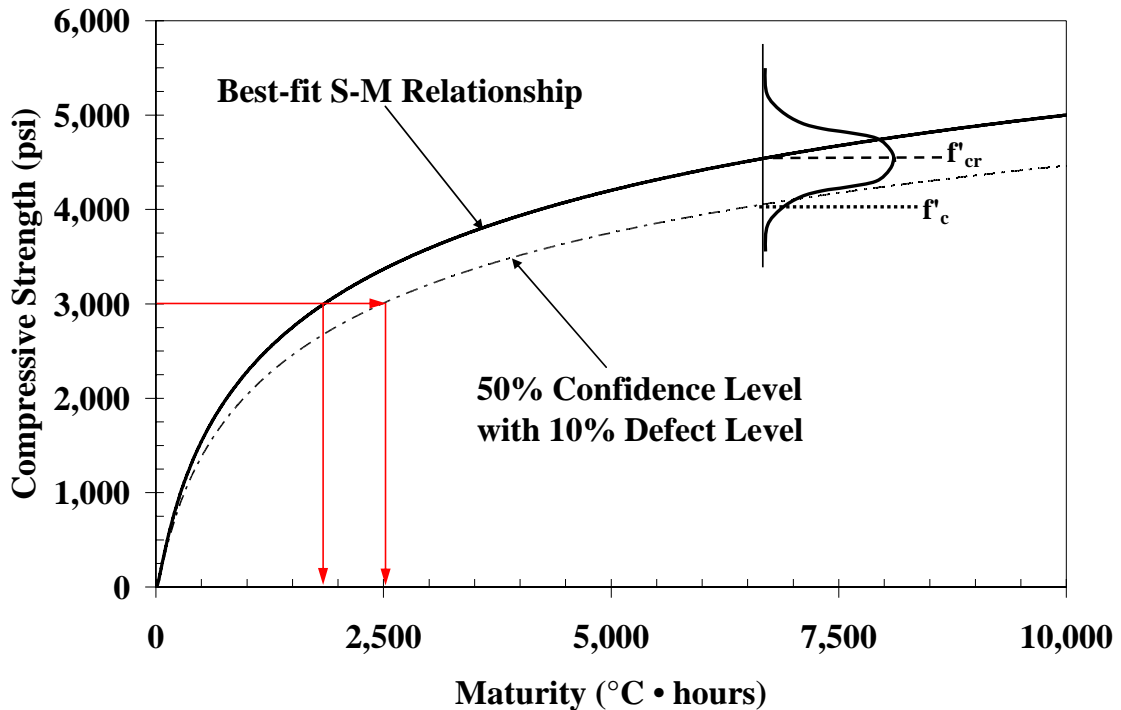

Figure 2-21: Confidence level for a strength-maturity relationship

The Nurse-Saul maturity function with a datum temperature of 0 °C (32 °F) was used to create the strength-maturity relationship, and then a 50% confidence level with 10% defect level was applied using Equation 2-10 to create a confidence-level-based new strength-maturity relationship. If a specified design strength of 3,000 psi was required to proceed with the construction process and the strength-maturity relationship with 50% confidence levels with 10% defect level was used, then the verification test could be performed when the in-place maturity index reached 2,500 °C • hours. If the test result falls above the 50% confidence level with 10% defect level line then one would feel

confident that the strength in the structure had reached adequate strength as 90% of the strength would exceed f'_c .

Stone, Carino, and Reeve (1986) criticized the approach by Hindo and Bergstrom because the variability of the concrete strength of cylinders is not equal to the variability of the in-place testing method. In response to the deficiencies of the Hindo and Bergstrom approach, Stone, Carino, and Reeve (1986) developed another technique. This technique is tedious and requires a computer program (Carino 1993). Carino (1993) proposed an alternative method to the one developed by Stone, Carino, and Reeve that was simpler and reasonably accurate. Carino (1993) reported that even though the “tolerance limit approach [Hindo and Bergstrom (1985) method] resulted in lower estimates of in-place characteristic strength, especially when the variability of the in-place results was high” the estimations are on the conservative side and could still be used in the construction process. Therefore, a 50% confidence level, along with the commonly used level of 75%, was evaluated during this research project.

2.8.2 PULLOUT TEST

The pullout test is a semi-non-destructive testing method involving the pulling out of an insert that has been embedded in the structure. From the force required to pullout out the insert, an estimate of the compressive strength can be determined using a pre-established correlation between pullout force and the compressive strength of the concrete. The advantage of the pullout test is that an accurate estimate of the in-place concrete strength is obtained. The actual effect of curing and construction conditions on the concrete strength is tested when the pullout test is used. The pullout test is a good method of

testing the in-place concrete strength so that critical construction processes can continue. The pullout test does not require extra concrete and cylinders to be made in the field, and the equipment used to perform the test is simple to operate, relatively light in weight, and portable.

2.8.2.1 Background of the Pullout Test

The pullout test equipment measures the force required to pull out a metal insert that is embedded into the concrete surface. The pullout machined attached to a form-mounted insert is shown in Figure 2-22.



Figure 2-22: Pullout test equipment

A relationship is used to relate the ultimate pullout force to the compressive strength of the concrete. Figure 2-23 depicts a pullout insert embedded close to the

concrete surface. A loading ram, which is connected to the insert and which transmits the forces to the concrete through a bearing ring, loads the insert. A conical-shaped fracture surface is created due to the test geometry. The term apex angle refers to two times the angle (α) between a line drawn from the edge of the head of the insert to the bearing ring and a vertical line drawn from the edge of the head of the insert.

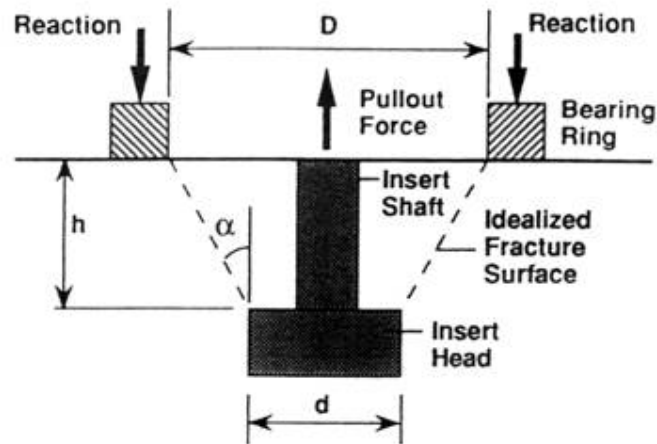

Figure 2-23: Schematic of the pullout test (Carino 1991)

Carino (1991) reported that the earliest known development of the pullout test began at the Central Institute for Industrial Building Research in the Soviet Union by Skramtajew. The pullout system was then continually modified by researchers around the world. These modifications continued for years until Kierkegaard-Hansen developed a pullout test that eventually became the common standard for the industry.

Kierkegaard-Hansen (1975) conducted a research project to find the optimum geometry of the pullout test for use in the field with simple equipment. The testing proved that a high correlation between the ultimate pullout force and the compressive strength can be obtained. Through a series of studies, Kierkegaard-Hansen established the

embedment depth, diameter of the insert's head, and the bearing ring diameter for optimum correlation to the compression strength. The optimum embedment depth of the insert was determined to be 25 mm (1 in.). As for the diameter of the head, it was concluded that the diameter of the disc did not appear to greatly influence the behavior of the test; therefore, a diameter of 25 mm (1 in.) was chosen. The optimum bearing ring size was determined to be 55 mm (2.2 in.). For this geometry, the apex angle is equal to 62°. A schematic of the Kierkegaard-Hansen insert geometry is shown in Figure 2-24. In the United States, the Lok-Test system, supplied by Germann Instruments, has the same configuration as shown in Figure 2-24.

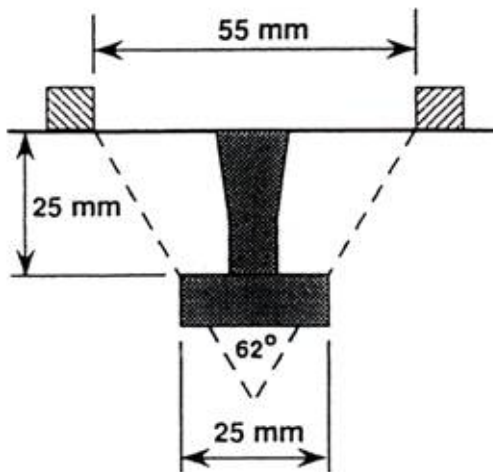

Figure 2-24: Kierkegaard-Hansen's configuration for the pullout test (Carino 1991)

Many researchers and others in the industry have concluded that the pullout test is an accurate means of testing in-place strength. Carino (1997) stated, "The cast-in-place pullout test is one of the most reliable techniques for estimating the in-place strength of concrete during construction." Bungey and Soutsos (2000) also believed that the pullout test is an accurate test and stated "that pull-out and pull-off tests can be successfully

applied to concrete in structures to yield estimates of in-situ strength.” Kierkegaard-Hansen and Bickley (1978) concluded “the Lok-Test system of pull out tests offers a simple, reliable, economic, and non-destructive way of determining the actual in-place strength of concrete at all strength levels in a practical statistically valid manner.” Hubler (1982) summarized that “the Lok-Test allows concreting to be done with far better control than with any other testing method, and as is close to a fail-safe system as modern technology has, as yet, devised.” Malhotra and Carette (1980) concluded that “in situ strength of concrete can be quantitatively determined using the pullout technique. The technique is simple, effective, and cheap, and test results can be reproduced with an acceptable degree of accuracy.” Therefore, the pullout test is an accurate and simple in-place test with which many in the industry feel very confident.

2.8.2.2 Failure Mechanism of the Pullout Test

Once Kierkegaard-Hansen (1975) had established the optimum pullout insert system, a couple of research projects were then devoted to understanding the failure mechanism of the pullout test. Most of the research were in the form of analytical studies; however, two major experimental studies were conducted. Carino (1991) stated that since “the stress distribution is not easy to calculate, the state of stress is altered by the presence of coarse aggregate particles, and the fundamental failure criterion for the concrete is not completely understood.”

A large-scale test was done on the failure mechanism of the pullout test by Stone and Carino (1983) for the National Bureau of Standards (changed in 1988 to the National Institute of Standards and Technology). The test was scaled up 12 times to allow the

embedment of strain gauges on the inserts. Stone and Carino found that there were three phases to the failure sequence, and these are shown in Figure 2-25.

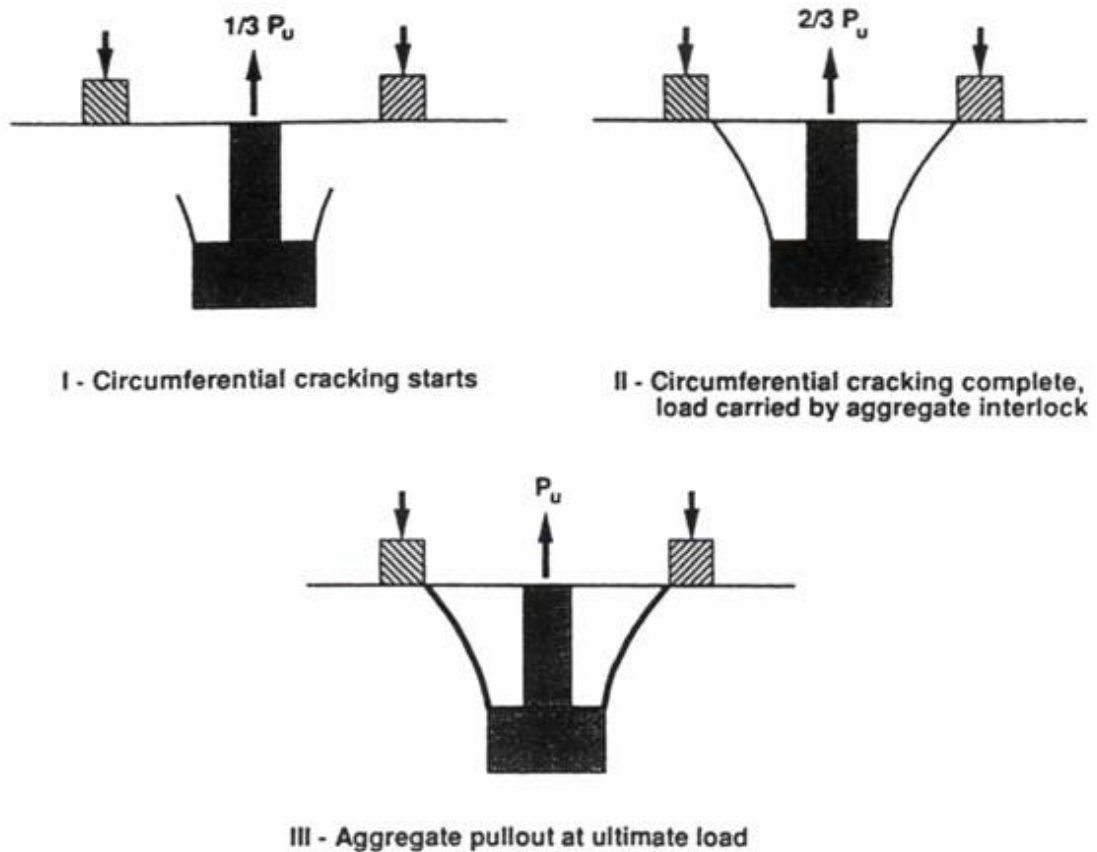

Figure 2-25: Sequence based on NBS large-scale pullout test (Carino 1991)

- Phase I - At about 1/3 of the ultimate load, circumferential cracking at the edge of the insert head begins.
- Phase II - At about 2/3 of the ultimate load, the circumferential cracking is completed connecting the insert head to bearing ring.
- Phase III - At 80% of the ultimate load, shear failure and degradation of the interlock between aggregates begins.

Stone and Carino (1983) concluded that the ultimate load-carrying mechanism was the interlock between aggregates which is shown in Phase III Figure 2-25. Figure 2-26 is an illustration of this aggregate interlock failure. Carino (1991) states that if the displacement was perpendicular to the failure crack, the section would separate with no extra force needed. As Figure 2-26(b) shows, the movement is inclined to the failure crack creating an interlock between the upper section and the aggregate. Therefore, a force is transmitted across the surface which requires a higher force to be applied to remove the upper section. This extra force is the shear failure mode explained in Phase III. This means that the ultimate load for the test is obtained when the coarse aggregate present on the interface of the crack is completely removed from the cement paste around this region (Carino 1991).

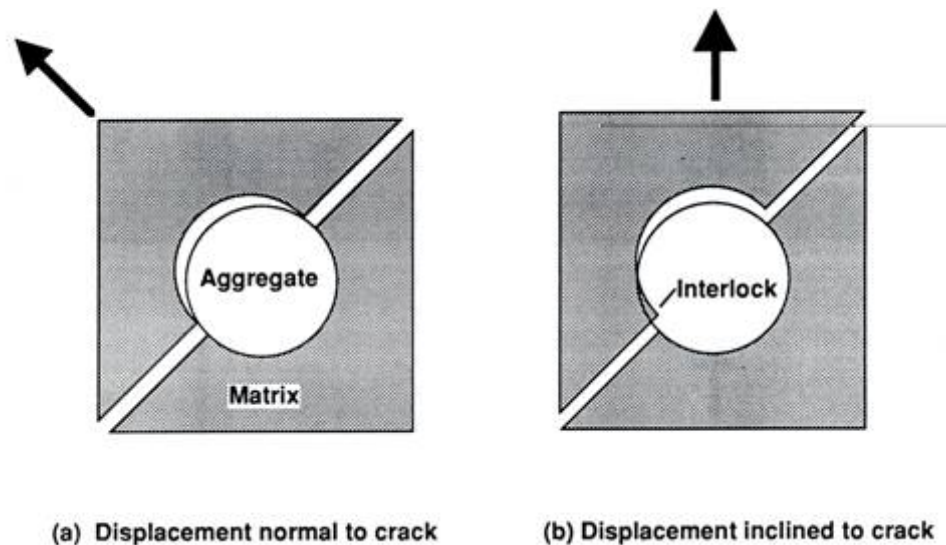

Figure 2-26: Model to illustrate aggregate interlock mechanism during pullout test (Carino 1991)

Krenchel and Shah (1985) also conducted a study of the failure planes of the pullout test. Krenchel and Bickley (1987) concluded from the Krenchel and Shah study that two circumferential crack systems are involved in the failure. The first and primary cracking mode begins at 30% to 40% of the ultimate load. The cracking extends from the head of the insert at an angle between 100° to 135° , from the vertical surface of the top of the head, to a point below the bearing ring. The second cracking system is the one that defines the conical shaped failure region of the concrete surrounding the insert and becomes fully developed at the ultimate load. Krenchel and Bickley concluded that three stages of failure mechanism existed as shown in Figure 2-27.

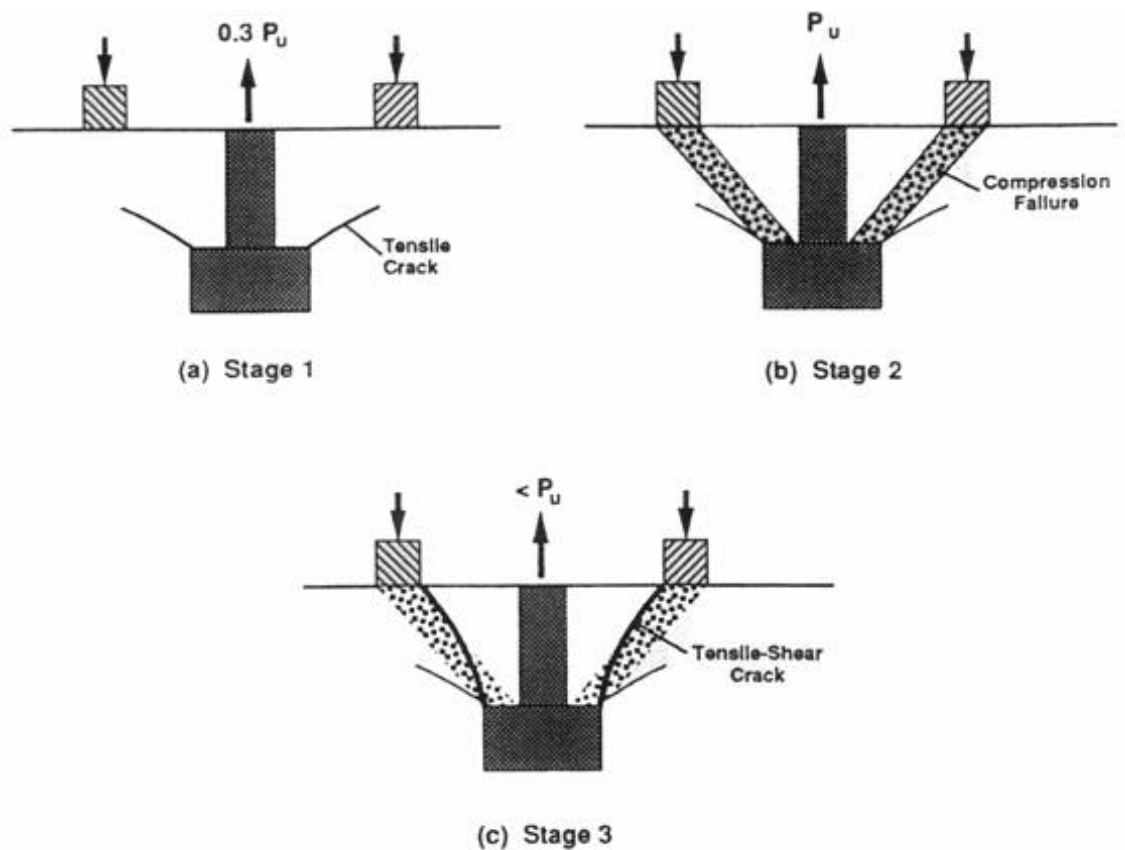

Figure 2-27: Failure mechanism of pullout test according to Krenchel and Bickley (Carino 1991)

- Stage 1 - Load between 30% to 40% of the ultimate load, “tensile cracks” begin at the head of the insert.
- Stage 2 - In the truncated zone numerous stable micro-cracks develop from compressive stresses. The cracks connect the insert head to the bearing ring.
- Stage 3 - A circumferential crack develops at the ultimate load which forms the final conical shaped failure region.

Krenchel and Bickley (1987) state that since the “micro cracking that occurs in stage 2 is responsible for and directly related to the ultimate load in this testing procedure it seems quite logical that such close correlation with the concrete *compressive* strength is always obtained.” It is this reasoning that allows the conclusion that with the correct geometry of the pullout system, a compressive failure can be obtained and in doing so, a correlation can be made between the pullout load and compressive strength of the concrete.

Carino (1991) concluded that the failure mechanism for the pullout test is either a compressive failure or a shear failure due to the interlock between the aggregate and paste. Even though there is a lack of agreement on the exact failure plane, Carino (1991) points out that there is a good correlation between pullout strength and compressive strength of the concrete and that the pullout test has good repeatability.

2.8.2.3 Variability of the Pullout Test

“Repeatability,” also known as with-in test variability, refers to the scatter of test results when the test is performed multiple times with the same personnel, equipment, and procedures (Carino 1991). Carino also states that the number of tests to be performed for any test procedure to obtain the average strength is determined by the repeatability of the test and certainty desired. The pullout test has proven to be a very reliable test method. Bickley (1982) conducted a review of about 4,300 pullout tests and revealed that the standard deviation of the ultimate pullout strength was constant. Figure 2-28 shows data from Stone, Carino, and Reeves (1986) that compares the coefficient of variation versus average pullout load for three different aggregates at an apex angle of 70°. The second series used the same gravel as the first series but an apex angle of 54° was tested. For normal aggregates the coefficient of variation ranges from 4% to 15%.

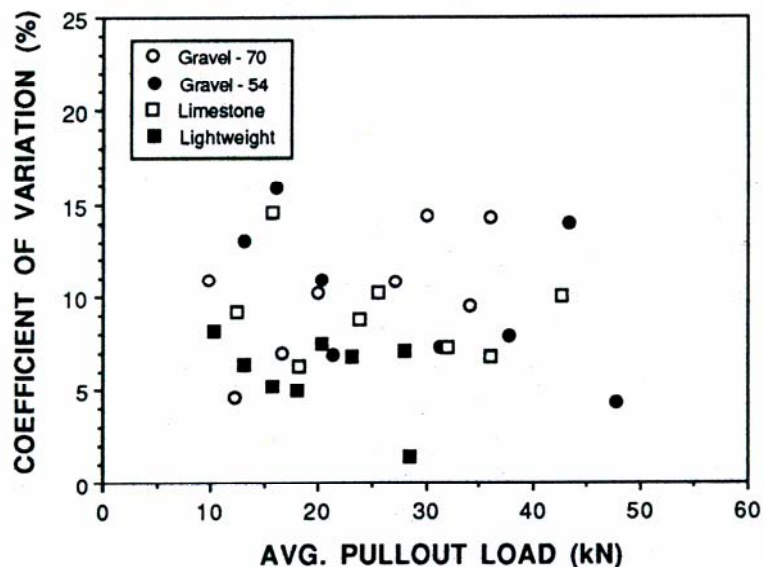

Figure 2-28: Repeatability of the pullout test for different aggregates from Stone, Carino, and Reeve study (Carino 1991)

The coefficient of variation results of all the researchers' tests with different aggregates, apex angles, embedment depth, and maximum aggregate sizes are presented in Table 2-5. The average values for the coefficient of variation vary from 4% to 15% with an average value of 8% (ACI 228.1R 2003).

Table 2-5: Summary of within-test coefficient of variation of pullout test (ACI 228.1R 2003)

Reference	Apex Angle (degrees)	Embedment Length +		Max. Aggregate Size		Aggregate Type	No. of Replication Specimens	Coefficient of Variation (%)	
		mm	in.	mm	in.			Range	Average
Malhotra and Carette (1980)	67	50	2.0	25	1	Gravel	2	0.9 - 14.3	5.3
Malhotra (1975)	67	50	2.0	6	1/4	Limestone	3	2.3 - 6.3	3.9
Bickley (1982)	62	25	1.0	10	3/8	-	8	3.2 - 5.3	4.1
Khoo (1984)	70	25	1.0	19	3/4	Granite	6	1.9 - 12.3	6.9
Carette and Malhotra (1984)	67	50	2.0	19	3/4	Limestone	4	1.9 - 11.8	7.1
	62	25	1.0	19	3/4	Limestone	10	5.2 - 14.9	8.5
Keiller (1982)	62	25	1.0	19	3/4	Limestone	6	7.4 - 31	14.8
Stone, Reeve, and Carino (1986)	70	25	1.0	19	3/4	Gravel	11	4.6 - 14.4	10.2
	70	25	1.0	19	3/4	Limestone	11	6.3 - 14.6	9.2
	70	25	1.0	19	3/4	Low Density	11	1.4 - 8.2	6.0
	54	25	1.0	19	3/4	Gravel	11	4.3 - 15.9	10.0
Bocca (1984)	67	30	1.2	13	1/2	-	24	2.8 - 6.1	4.3

+ *Embedment length* is the same as the *embedment depth* used in for this thesis.

Stone and Giza (1985) conducted a study to investigate the coefficient of variation with changes in the apex angle, embedment depth, aggregate size, and aggregate type. Figure 2-29(A) shows the effect of varying the apex angle. Figure 2-29(B) shows the coefficient of variation for various embedment depths. Figure 2-29(C) shows the effects of changes in aggregate size. Figure 2-29(D) show the effects of varying aggregate type.

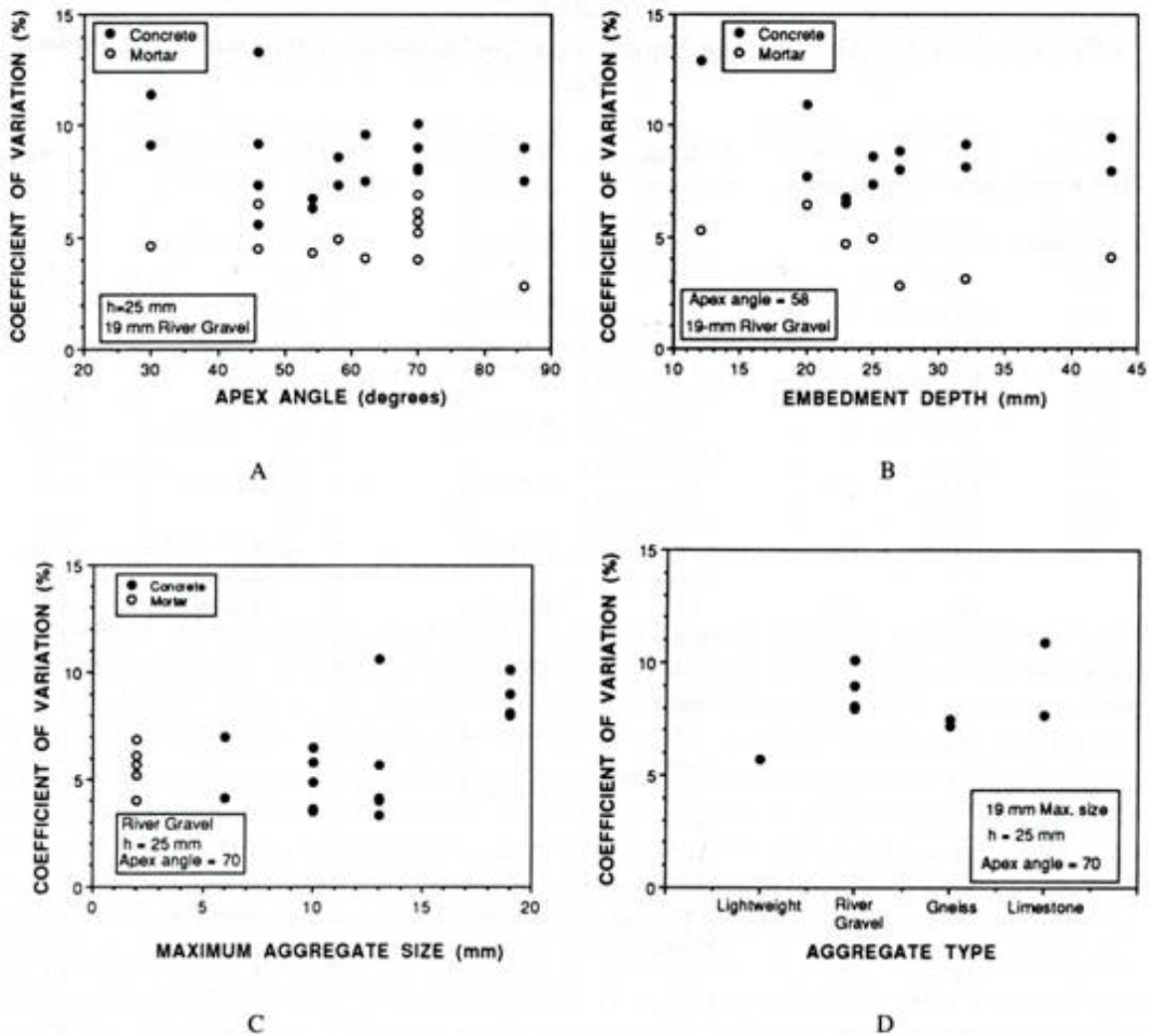

Figure 2-29: Coefficient of variation as a function of: (A) apex angle, (B) embedment depth, (C) maximum aggregate size, and (D) aggregate type (Carino 1991)

The apex angle ranges between 30° to 86° and does not have a large effect on the repeatability. Like the apex angle, the embedment depth does not greatly affect the repeatability. For varying aggregate size, the coefficients of variation are very close for aggregates sizes of 6, 10, and 13 mm. For the aggregate size of 19 mm, the average coefficient of variation was slightly higher than the others. Finally, for varying aggregate types the coefficients of variation are the same for normal aggregates, and the lightweight aggregate has a lower average coefficient of variation.

The average coefficient of variation for the pullout test is around 8% according to ASTM C 900 (2001) and Carino (1991). It has been shown that the repeatability of the pullout test can be relatively high, therefore larger number of tests should be conducted to determine the average pullout strength. ASTM C 900 (2001) recommends that a minimum of five tests be conducted each time because of the relatively high coefficient of variation.

2.8.2.4 ASTM C 900 Summary

ASTM C 900 (2001) is the only American specification that details the used of the pullout test. The standard allows for the use of cast-in-place inserts and post-installed inserts. Prior to application of the pullout system to test the in-place strength, the pullout force to compressive strength relationship must be established or verified. The standard states that the diameter of the head of the insert must be equal to the embedment depth and that the bearing ring inside diameter must be 2.0 to 2.4 times the diameter of the head of the insert. Tolerance for dimensions of the inserts shall be $\pm 2\%$. Specifications for the

pullout apparatus are also given, and the commercially available Lok-Test meets all of these specifications.

Spacing of the pullout inserts is subject to two requirements: the clear spacing between inserts must be at least eight times the head diameter, and the clear spacing between an insert and the edge of the concrete must be at least four times the diameter of the head. Also, inserts must be placed in such a manner that reinforcement is outside the expected conical failure surface by more than one reinforcement bar diameter or maximum aggregate size. A minimum of five tests must be conducted to assess the in-place strength. Inserts must be located in the area(s) of the structure where critical exposure conditions exist or specific structural design strengths must be met. Both form-mounted and floating inserts are allowed (discussed in Section 2.8.2.5). The load rate for testing the pullout insert is 70 ± 30 kPa/s (10.2 ± 4.4 psi/s). The pullout force is to be recorded to the nearest half of the least division on the dial. Tests should be rejected if the large end of the conical section is not a complete circle, the distance from the surface of the bearing ring to the head is not the same as the diameter of the head, or if a reinforcement bar is visible when the conical section is removed. The coefficient of variation is 8% for a test with maximum aggregate size of 19 mm and embedment depth of 25 mm. The percent range of compressive strength values is defined in Equation 2-11.

$$\%Range = \left(\frac{S_{max} - S_{min}}{S_{avg}} \right) \times 100 \quad \text{Equation 2-11}$$

where, S_{max} = maximum compressive strength from all tests (psi),
 S_{min} = minimum compressive strength from all tests (psi), and
 S_{avg} = average compressive strength of all tests (psi).

Using this expression, ASTM C 900 (2001) states that the acceptable ranges for the pullout tests are 31% for 5 inserts tested, 34% for 7 inserts tested and 36% for 10 inserts tested.

2.8.2.5 Application of Pullout Test

ACI Committee 228 recommends various methods to estimate correlation between the pullout test and compressive strength in the laboratory (ACI 228.1R 2003). The first is to install a pullout insert at the bottom of a 6 x 12 inch cylinder, and then break the cylinders in compression (Bickley 1982). The pullout test is stopped at the ultimate load, and the insert is not pulled out completely, so that the cylinder can be capped and then tested in compression. Another method is to cast a set of cylinders to be broken in compression and to cast a set of cylinders with inserts installed in the bottom only to be used for the pullout test. Both sets are tested simultaneously to obtain a pullout force and compressive strength. However, problems have developed when using the pullout installed in a 6 x 12 inch cylinder. When the pullout insert is tested, radial cracking may occur, causing the ultimate pullout strength to decrease.

A different method, which minimizes radial cracking, is to make concrete cubes with the inserts on the faces of the cube. The recommended minimum size of the cubes is 8 inches when a 1-inch embedment depth insert is being used (ACI 228.1R 2003). On each vertical wall, one insert can be placed in the center so that a total of four inserts can be tested from one cube. The cubes are made along with cylinders to compare the pullout force to the compressive strength. As long as the compaction is consistent between the

cylinders and the cubes, the test should be consistent in comparing the ultimate strengths of the pullout to the compressive strength.

In the field, the pullout equipment is simple, easy to perform, and the test can be conducted by one person. The insert can be installed in several different ways. The first method is to attach inserts to the forms before the concrete is cast. This setup is pictured in Figure 2-30. An alternate method is to install a “floating insert” in the top surface of the concrete after the concrete has been poured, as shown in Figure 2-31.



Figure 2-30: Form-mounted pullout inserts



Figure 2-31: Floating pullout inserts

Floating inserts should be installed according to the manufacturer's instructions. The floating insert is more difficult to install than the form-mounted insert. After the form inserts are positioned and covered by concrete, no additional work is needed until the testing. When the maturity reaches the desired level, the pullout test can be conducted to verify the strength of the concrete.

2.8.3 COMPRESSIVE STRENGTH OF CORES

Many variables affect the strength of cores and there have been many different means employed to interpret the strength of cores. Compressive strength of cores was only considered for this project because it is an ALDOT standard testing method for assessing the in-place strength of an existing structure. The inherent problems and different core conditioning methods are discussed in this section.

2.8.3.1 Background on Core Testing

Analysis of test results obtained from testing cores can be affected by many different variables (Suprenant 1985). As ACI 214.4R (2003) states, "the analysis of core test data can be difficult, leading to uncertain interpretations and conclusions." The reasons that ACI 214.4R (2003) lists for the difficulties that occur with testing cores include.

1. Systematic variation of in-place concrete strength along a member and throughout the structure,
2. Random variation of concrete strength, both within one batch and among batches,

3. Low test results attributable to flawed test specimens or improper test procedures,
4. Effects of the size, aspect ratio, and moisture condition of the test specimens, and
5. Additional uncertainty attributable to the variation in testing that is present even for tests carried out in strict accordance with standardized testing procedures.

Extensive research has been conducted around the world on the relationship of compressive strength of cores to compressive strength of molded specimens, and the general consensus is that core strengths tend to be lower than molded specimen strengths. Bloem (1968) states, “strength in place as measured on drilled cores will be less than that of moist-cured molded cylinders tested at the same age and will probably never reach the standard 28-day strength even at greater ages.” He also recommends that core tests, which are used to evaluate deficiencies in strength that were indicated by low strength from molded cylinders, should be interpreted with caution. He found in multiple cases that the core strengths never reached the design strength. Also Bloem (1965) indicated that the measured strength from cores removed from a structure vary significantly due to the curing method and test specimen conditioning.

Some of the reasons that compressive strengths of cores could be lower than the strength obtained from molded cylinders are outlined in ACI 214.4R (2003). These reasons are related to differences in bleeding, consolidation, and curing conditions. Szypula and Grossman (1990) concluded that core strengths are reduced by the presence

of microcracking and could not be relied upon to determine the nominal compressive strength. If cores are removed from an area in the structure that has been subjected to the stress of applied loads or restrained from imposed deformations, microcracking could be present, causing the strength of the cores to be lower (ACI 228.4R 2003). Microcracking can also occur when cores are being removed or if they are not handled properly.

Munday and Dhir (1984) conducted a study to determine the effects of core diameter, slenderness ratio, location and curing on core strengths, and the characterize the cube/core strength relationship. Conclusions drawn from the study were that cores smaller than those recommended by ASTM could be used to evaluate the in-place strength, but that a higher number of cores than recommended should be tested in order to obtain accurate test results. The slenderness ratio (length/diameter, L/D) effects varied with strength, and practices at the time for adopting a single set of correction factors for calculating specimen strength tended to be over-simplified. When cores were removed perpendicular to the direction of casting, they were an average 8% weaker than cores that were removed vertically. Cores that were removed at higher locations in a single pour were weaker than cores removed from lower locations of the same pour. They concluded that the relationship between the cores and molded specimen strengths for specimens with an L/D of 2 was a variable relationship. The method of using a single factor to estimate the cube strength from a core resulted in inherent problems.

Studies have been conducted to compare the effects of different curing methods on the strength of core specimens. Bloem (1965) concluded that, “it appeared that cores dried for 7 days to eliminate water absorbed during drilling provided the most accurate measure of strength in place.” Bartlett and MacGregor (1994) conducted a study to

determine the magnitude of the difference between the strength of cores that were air-dried and those that were soaked in water. This study revealed that the strengths of cores that were dried for 7 days were an average of 14% larger than those that were soaked for at least 40 hours before testing. Bartlett and MacGregor (1994) also found that the most representative strength was obtained from cores obtained by “air-cooled drill or by letting excess water evaporate from cores obtained using a water-cooled drill.” They concluded that the 7-day air-drying treatment was too long for allowing excess cooling water to evaporate.

Many factors affect the strength of cores; therefore, there is not one simple method of interpreting the strength results obtained from testing cores. Some of the problems can be avoided by using good quality control procedures for removing and testing cores, but there is not a consensus on how to handle all the problems. ASTM C 42 (2004) and AASHTO T 24 (2002) take different approaches to specify how cores should be conditioned before testing. Both organizations’ standards recognize the problems related to core testing and state “that there is no universal relationship between the compressive strength of a core and the corresponding compressive strength of standard-cured molded cylinders” (ASTM C 42 2004 and AASHTO T 24 2002).

Since there are many variables that affect the strength of cores, there is a higher coefficient of variation for cores than there is for compressive tests of molded concrete cylinders. Both ASTM C 42 (2004) and AASTHO T 24 (2002) recommend a coefficient of variation of 4.7% for cores with concrete strengths ranging from 4,500 to 7,000 psi that have a diameter of 4 inches. Accordingly, the range for cores should not differ by more than 13% (as defined in ASTM C 42). The range is calculated using Equation 2-11.

2.8.3.2 Comparison of ASTM C 42 and AASHTO T 24

Both ASTM C 42 (2004) and AASHTO T 24 (2002) have some of the same requirements for removal of cores and correction values for calculations. When removing the specimens from the structure, both ASTM C 42 and AASHTO T 24 state that the concrete must be hard enough so that there is no disruption between the bond of the mortar and the coarse aggregate. If the sample is damaged in any way, then it must be discarded. Also the cores cannot be removed from an area where cracks are present.

ASTM C 42 requires that the diameter for cores used in compression testing be at least 3.70 inches for concrete with maximum aggregate size less than 1.5 inches. AASTHO T 24 requires the diameter of the core to be 4 inches or greater for concrete with maximum aggregate size less than 1.5 inches. When the maximum aggregate size is greater than 1.5 inches, both ASTM C 42 and AASTHO T 24 suggest that the diameter should be at least three times the maximum aggregate size. Both methods allow a smaller diameter to be used only when necessary to maintain an L/D greater than 1.

The recommend L/D for both methods is between 1.9 and 2.1. Once the specimen L/D falls below 1.75, correction factors must be applied for the ASTM method. For the AASTHO method, if the L/D falls below 1.94, correction factors must be applied, and if the L/D exceeds 2.1, a reduction factor has to be applied. Both methods also require that specimens be discarded if the length before capping is less than 95% of the diameter.

The major difference between these two organizations' standard is the method for conditioning of the cores after removal. Once the cores are removed, ASTM C 42 requires the free surface drilling water to be wiped off and the core to remain outside so that surface moisture from the drilling process can evaporate. The core shall not remain

outside for more than an hour. The cores are placed in separate plastic bags to prevent moisture loss, and the cores are maintained at ambient temperature. The cores are kept in plastic bags at all times except for end preparation and 2 hours for capping. The cores must remain in the sealed plastic bags for at least 5 days following the last exposure to water. This method is intended to preserve the moisture conditions of the concrete from which the cores were removed. AASHTO T 24 requires that the cores be submerged in a lime-saturated water bath conditioned at 73 ± 3 °F for at least 40 hours prior to testing.

Before testing according to either method, each core's length and diameter must be measured. Capping the cores with a sulfur compound is required in each standard. Compressive testing is then done in accordance with ASTM C 39 (2003) and AASTHO T 22 (2005), respectively. Correction factors are applied, when prescribed, to the strength data for both methods. The correction factors are only applied to concrete with strengths ranges from 2,000 to 6,000 psi. In addition, the correction factors only apply to normal-weight concrete and concrete with a unit-weight between 100 and 120 psf.

2.8.4 COMPRESSIVE TESTING OF CAST-IN-PLACE CYLINDERS

ASTM C 873 (2004) is the standard specification that governs testing of cast-in-place cylinders. The use of cast-in-place cylinders is recommended by ASTM C 1074 (2004) to verify the strength estimated by the maturity method. The cast-in-place concrete cylinder method is a technique that allows molded concrete cylinders to be tested that were removed from the structure without having to core the concrete. The objective of using the cast-in-place cylinder is to capture the thermal history of the concrete in the structure

(ACI 228.1R 2003). When the compressive strength is needed, the cylinder is removed and tested in the same way molded concrete cylinders are tested.

Cast-in-place concrete cylinders have variability similar to normal molded cylinders. Bloem (1968) found the within-test coefficient of variation range from 2.7% to 5.2% with an average of 3.8%. Carino, Lew, and Volz (1983) found the average coefficient of variation to be equal to 3.8%. ASTM C 873 (2003) recommends a single-operator coefficient of variation of 3.5% for compressive strengths from 1,500 to 6,000 psi. No correlation between cast-in-place concrete cylinders and molded concrete cylinders is needed to compare the strength of the two (ACI 228.1R 2003). The cast-in-place cylinder testing method is a simple method that, with enough advanced planning, can be an accurate means of measuring the in-place strength.

2.8.4.1 ASTM C 873 Mold Requirements

ASTM C 873 (2003) specifies that cast-in-place cylinders can only be used with depths between 5 and 12 inches. ASTM C 873 (2003) has recommendations for the geometry and design of the cast-in-place cylinder molds. L/D should be between 1.5 and 2, but not less than 1 after capping of the specimen. The inside diameter of the mold must be larger than three times the nominal maximum aggregate size. The inside diameter of the mold shall not be less than 4 inches, with the average diameter not differing from the nominal diameter by more than 1%, and no individual diameter differing from any other by more than 2%. The sides of the mold must be perpendicular within 0.5° to the rim and bottom of the mold. Molds shall be watertight and not made of absorbent material or a material that reacts with concrete containing portland cement. Molds shall be made sufficiently

strong so that they will not deform or break. Molds are to be fastened to formwork using screws or nails. Figure 2-32 shows a diagram for the cast-in-place cylinder mold.

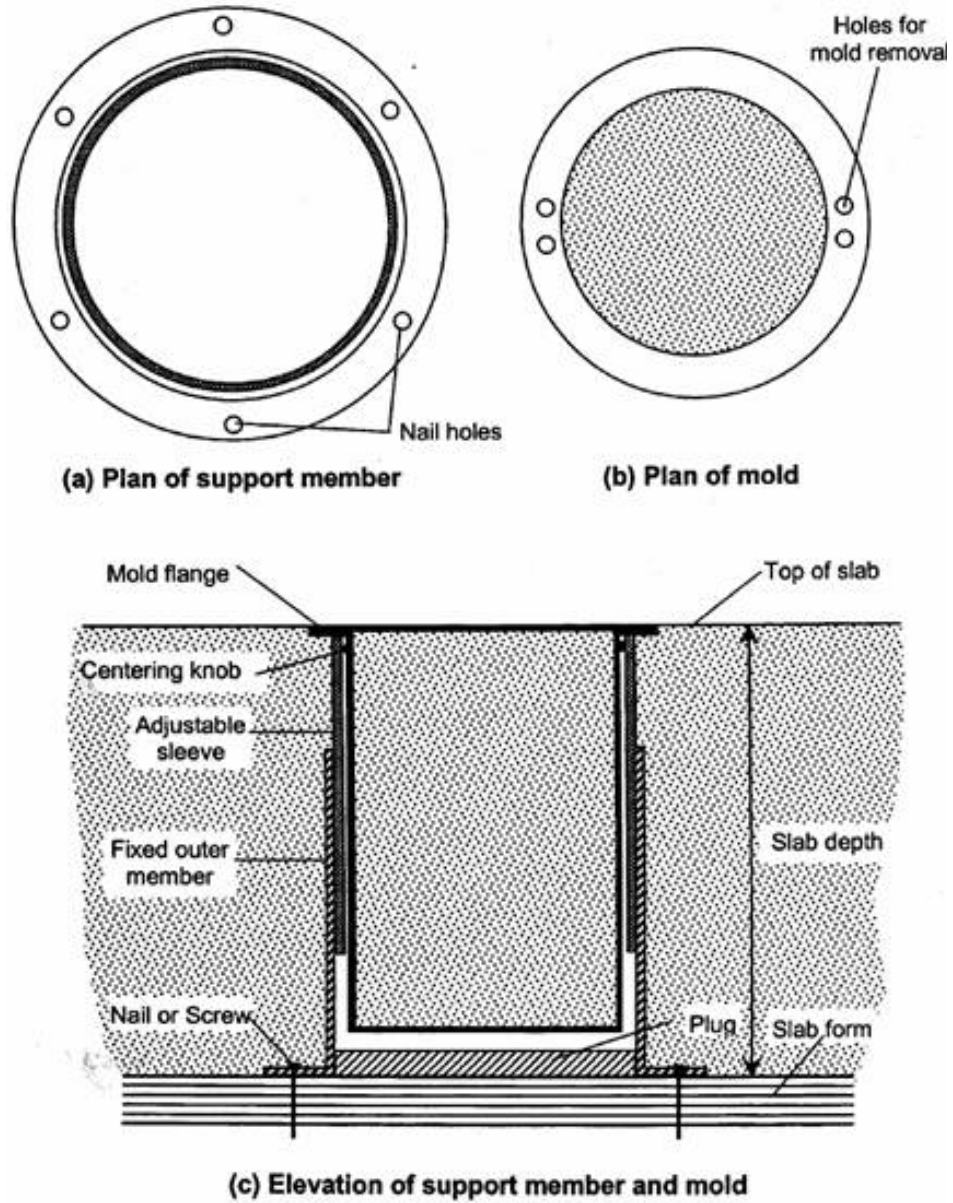

Figure 2-32: ASTM recommendation for the cast-in-place concrete cylinders molds (ASTM C 873 2003)

2.8.4.2 ASTM C 873 Cylinder Casting, Handling, and Testing

Consolidation of the concrete in the cast-in-place cylinder should be similar to that of the concrete surrounding the mold. For normal concrete, it is recommended that the surrounding concrete be vibrated and that the vibrator briefly touch the edge of the mold. Unless special circumstances exist, mechanical vibration inside the mold should not be applied. Curing of the specimens should be the same as for the surrounding concrete, and the specimens should not be removed until the strength of that location needs to be assessed. After removing the specimen, the temperature of the concrete should remain within ± 10 °F of the slab surface temperature. Transportation time for moving the specimens to the test site must not exceed 4 hours. The specimens are to be capped in accordance with ASTM C 617 (2003) and tested in accordance with ASTM C 39 (2003). No change to the moisture condition of the specimen is to occur unless specified. For cylinders with an L/D less than 1.75, the ASTM C 42 (2004) factors for strength correction are to be used. Two diameters of the molded specimen measured at a right angle to each other shall not differ by more than 1/16 inch.

2.9 SUMMARY

The maturity of concrete is based on the temperature history of the concrete. There are two common methods for calculating the maturity of concrete: the Nurse-Saul and Arrhenius maturity functions. The datum temperatures that are used most commonly for the Nurse-Saul maturity function are 0 °C and -10 °C (32 °F and 14 °F). For the Arrhenius maturity function, the common activation energies range from 33,500 to 45,000 kJ/mol, and the common reference temperature is 23 °C (73 °F). The Arrhenius

maturity function has been proven to be the more accurate function of the two, but the Nurse-Saul maturity function can be used with a high degree of confidence as well. Most transportation agencies that use the maturity method use the Nurse-Saul maturity function. When developing the strength-maturity relationships, there are three different functions most commonly used to estimate the strength of the concrete: exponential, hyperbolic, and logarithmic functions. The exponential and hyperbolic functions are the most accurate for modeling the strength gain of concrete.

A strength-maturity relationship is specific to each concrete mixture. Several factors other than temperature can affect the strength gain of concrete. These factors include the moisture for hydration, air content, and the presence of fine minerals in the coarse aggregate. In addition, high early-age curing temperature can affect concrete's long-term strength. Since some factors can affect the strength of concrete without affecting the temperature history of the concrete, extra steps should be taken to ensure that the strength-maturity relationship developed is valid. Confidence levels can be applied to the strength-maturity relationship to ensure that the concrete has met the required strength. Confidence levels need to be applied where critical strength is required to allow progression of different construction processes or opening the structure to applied loads.

To verify the strength-maturity relationship, cylinders can be made from concrete that is placed in the structure and tested to assure that the concrete supplied is the same as the concrete that was used to develop the strength-maturity relationship. In-place testing can also be used along with the maturity method to verify the strength of the concrete in the structure.

Reliable in-place testing methods are the pullout test and compression testing of cast-in-place cylinders. The pullout test has been proven to be an accurate method for estimating the in-place strength of concrete. The coefficient of variation is relatively high for the pullout test but reliable results can be obtained by increasing the number of pullout inserts tested. Cast-in-place cylinders have also been proven to give an accurate assessment of in-place strength, but more work must be conducted before the concrete is placed in order to use the cast-in-place system. Compression tests performed on cores can also be used to verify the in-place strength but extra planning is required. Many variables have been shown to affect the strength of cores; therefore, cores can produce inaccurate results of the in-place strength. Careful interpretation of the test results is needed to ensure adequate strength.

Multiple devices are available for recording the temperature development of concrete, and calculate the maturity of the concrete. Some of these devices are self-contained so that extra equipment is not necessary to record the temperature and maturity. As long as the recording device meets the ASTM C 1074 (2004) requirements, it should be sufficient.

CHAPTER 3

REVIEW OF LABORATORY TESTING PHASE

The objective of this chapter is to review the primary conclusions from the laboratory testing phase (Phase I) of Alabama Department of Transportation maturity project. Only a general review of the testing procedures, the results, and primary conclusions of Phase I are presented. The author of this thesis assisted with the laboratory phase; however, some of the contents of this chapter were obtained from Wade (2005). For a more detailed and thorough explanation of the results refer to Wade's thesis (2005) which outlines and discusses the laboratory testing phase in detail.

3.1 BACKGROUND

To evaluate the accuracy of the maturity method under laboratory conditions, a total of 13 different concrete mixtures were assessed. Type I and Type III cements along with multiple supplementary cementing materials (SCMs) were evaluated. The SCMs considered were: Class F fly ash, Class C fly ash, ground-granulated blast-furnace slag, and silica fume. Also evaluated were different water-to-cementitious materials (w/cm) ratios. Chemical admixtures were added to the concrete mixtures to achieve the desired slump and air content. The concrete mixtures that were evaluated were mixtures

commonly used on ALDOT construction projects. A summary of the mixtures can be found in Table 3-1.

Table 3-1: Concrete mixtures evaluated in the laboratory phase

Mixture Identification	Cementitious Materials Content	w/cm	Classification
CEMENT ONLY			
Type I - 0.48	620 lb/yd ³	0.48	Normal: A-1a
Type I - 0.44	620 lb/yd ³	0.44	Normal: A-1c
Type I - 0.41	658 lb/yd ³	0.41	HPC Bridge Deck
Type III - 0.44	620 lb/yd ³	0.44	Repair: A-1c
Type III - 0.37	705 lb/yd ³	0.37	Prestressed Girder
CLASS F FLY ASH			
20% F	658 lb/yd ³	0.41	Bridge Deck
30% F		0.41	Bridge Deck
CLASS C FLY ASH			
20% C	658 lb/yd ³	0.41	Bridge Deck
30% C		0.41	Bridge Deck
GGBF SLAG			
30% Slag	658 lb/yd ³	0.41	Bridge Deck
50% Slag		0.41	Bridge Deck
SILICA FUME			
70/20/10 - 0.44	620 lb/yd ³	0.44	HPC Bridge Deck: A-1c
70/20/10 - 0.37	705 lb/yd ³	0.37	Prestressed girder

The standard ALDOT concrete mixtures, A-1c and A-1a, defined in Section 501.02 (ALDOT 2002), were the concrete mixtures with 620 lb/yd³ of cement or cementitious material. The effects of the w/cm on the strength of the concrete were evaluated using cement-only mixtures. The SCMs were used as replacement to the Type I – 0.41 mixture. The percentages were based on the mass of cement replaced by

the SCMs. The mixture proportions for the SCMs were the same as the Type I – 0.41 mixture. This allowed the effects of the different SCMs on the strength development of the concrete, cured at different temperatures, to be evaluated. For the mixture labeled 70/20/10, the cementitious materials were made up of 70% Type I cement, 20% Class F fly ash, and 10% silica fume. These mixtures are also commonly referred to as ternary mixtures.

Three different curing conditions were evaluated. Each mixture was cured at three different temperatures: a controlled temperature was used as required by ASTM C 1074 (2004), a “cold” temperature, and a “hot” temperature. In order to mimic the field curing temperatures, “cold” and “hot” curing environments were designed to fluctuate. The “cold” curing condition was designed to simulate a winter ambient temperature cycle in Alabama and the “hot” curing condition was designed to simulate a summer ambient temperature cycle in Alabama.

Once all the strength and temperature data were obtained, the maturity was calculated for all of the concrete mixtures. Next the maturity method was applied to the concrete mixtures to evaluate its accuracy. The Nurse-Saul and Arrhenius maturity functions were both used to calculate the maturity index. The datum temperatures that were evaluated for the Nurse-Saul maturity function were 0 °C and -10 °C. The activation energies that were evaluated for the Arrhenius maturity function were 25,000 J/mol and 40,000 J/mol.

3.2 TESTING PROCEDURES

For each concrete mixture, a separate batch of concrete was made for each curing condition. Before the concrete was mixed, all mixing materials (cementitious materials, water, coarse aggregates, and fine aggregates) used for the hot and cold batches were heated or cooled to a temperature close to their respective curing temperatures. For each batch, 19 – 6 x 12 inch molded cylinders were made in accordance with AASHTO T 23 (2004). A temperature sensor was placed in one cylinder to record the temperature history of the concrete, and the sensor was programmed to record the temperature every 30 minutes, on average. After the cylinders were covered with snap-on plastic lids, they were moved to their respective curing conditions. The three curing conditions are as follows:

1. The controlled laboratory curing method maintained at constant temperatures between 68 °F and 73 °F,
2. The “hot” curing method maintained a cycling temperature between 90 °F and 105 °F, and
3. The “cold” curing method maintained a cycling temperature between 40 °F and 55 °F.

The cycling period for both “hot” and “cold” conditions was over 24 hours and was repeated every 24 hours. All of the curing methods used lime-saturated water baths. The temperature of the bath was controlled by a circulator that controlled the water temperature by circulating heated or cooled water through a series of copper pipes that oscillated through the lime-saturated water baths. For all three curing methods, the

desired curing temperatures are shown in Figure 3-1. To achieve the “hot” and “cold” curing methods two insulated water tanks were constructed one of which can be seen in Figure 3-2.

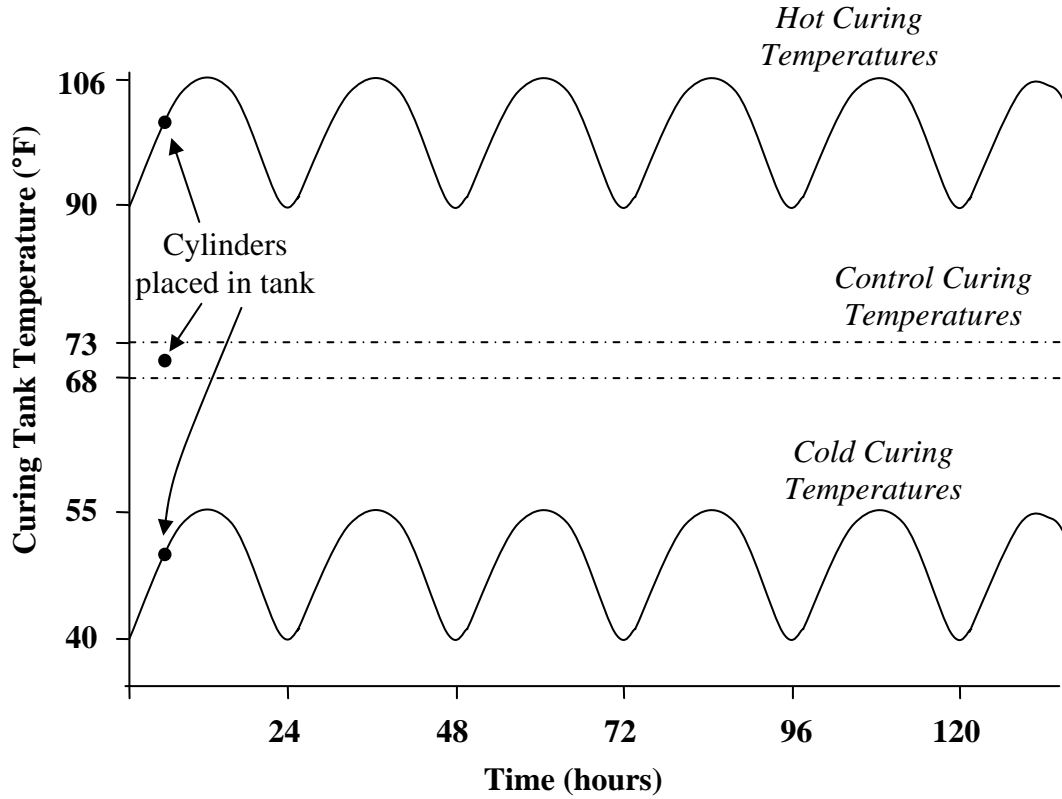

Figure 3-1: Temperature cycles of the three curing methods (Wade 2005)



Figure 3-2: Curing tank and programmable heating/cooling circulator

At the appropriate times, three cylinders were tested in compression in accordance with AASHTO T 22 (2003). A total of 18 cylinders were tested. The controlled curing condition's testing ages were: twice the final set time, 1, 2, 7, 14, and 28 days. For the "hot" and "cold" curing conditions, the equivalent ages for the respective curing conditions were calculated. This was done so that the strength data would be at approximately the same strength level for each batch of the same mixture. To calculate equivalent age, the control testing age was divided by the Nurse-Saul age conversion factor (Equation 2-4) using a datum temperature of -10 °C (14 °F). The average curing temperature for each curing method was used with a reference temperature of 23 °C (73 °F). For the "hot" and "cold" curing conditions, average temperatures were 98 °F (37 °C) and 47.5 °F (9 °C), respectively. Testing ages for the "hot" and "cold" curing conditions can be found in Table 3-2.

Table 3-2: Laboratory testing schedules

	Batch Identification		
	Control	Hot	Cold
Age of Concrete at Testing	2*t _s	2*t _s	2*t _s
	24 hr.	18 hr.	42 hr.
	48 hr.	35 hr.	84 hr.
	7 day	5 day	12 day
	14 day	10 day	25 day
	28 day	20 day	49 day

Note : t_s = final setting time

All compression testing was conducted using neoprene pads. The cylinders remained moist from the time they were removed from the water bath to the time they

were strength tested. This was done because the loss of moisture could cause a significant deviation in the compressive strength test results. Once all strength testing was completed, the temperature history of the concrete was obtained and the maturity was calculated.

3.3 TYPICAL RESULTS

Typical results found in the laboratory study showing the crossover effect are shown in the following figures. The concrete mixtures that are shown are: Type I – 0.41, Type I – 0.48, 20% Class F fly ash, 30% Class F fly ash, 20% Class C fly ash, 30% Class C fly ash, 30% slag, and 50% slag.

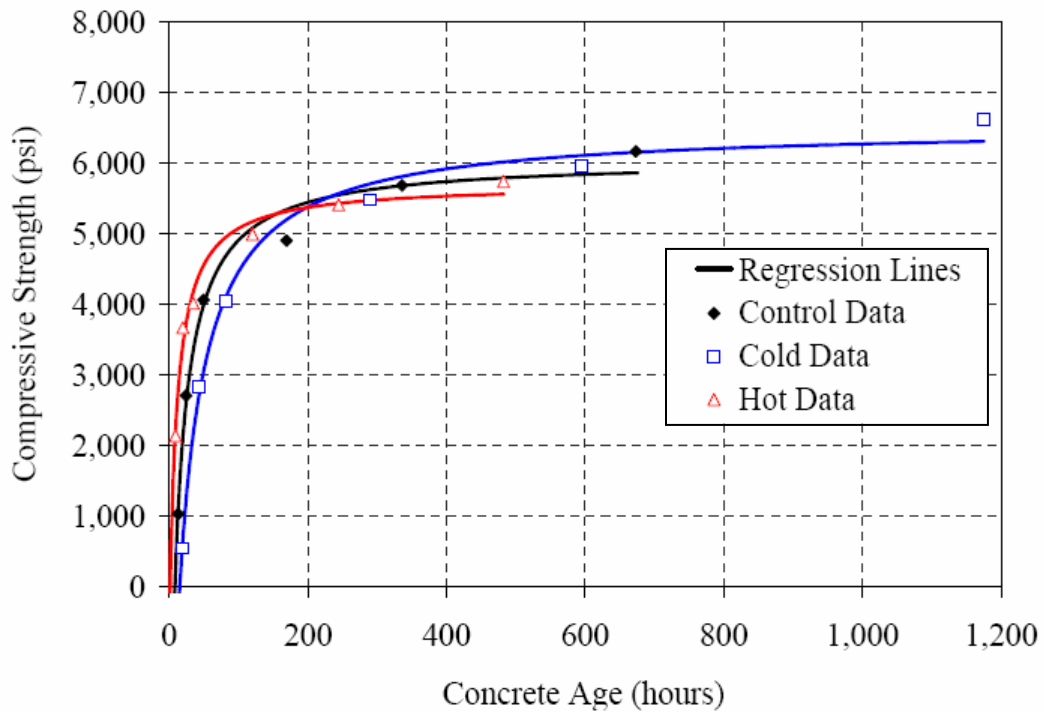

Figure 3-3: Compressive strength versus age results for Type I – 0.41 mixture (Wade 2005)

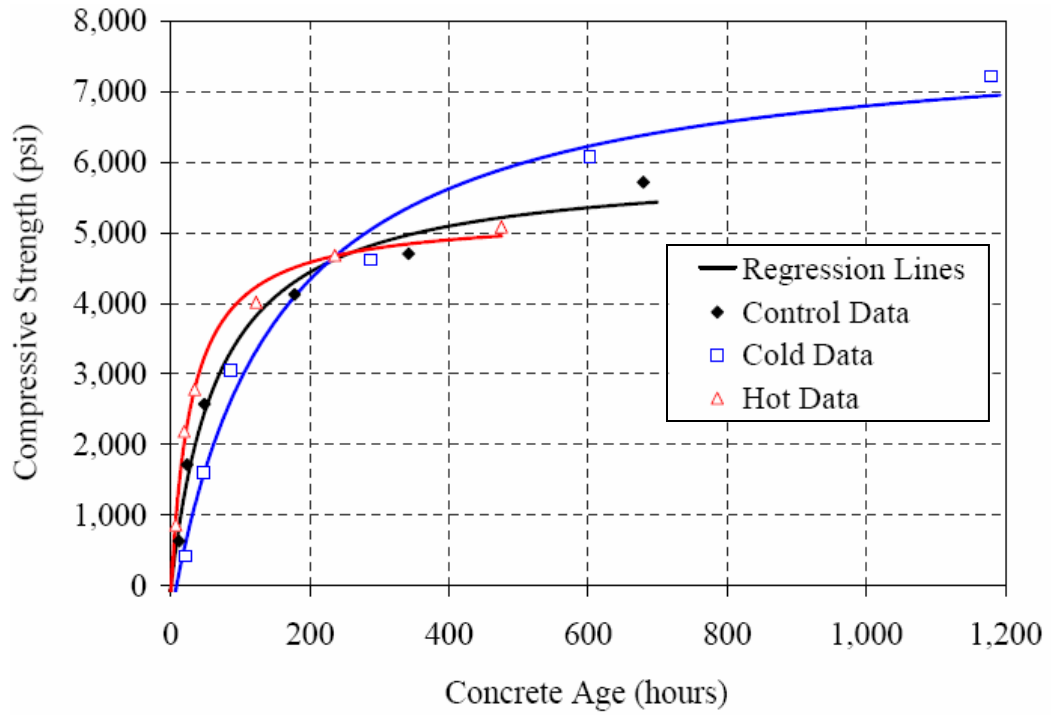

Figure 3-4: Compressive strength versus age results for Type I – 0.48 mixture (Wade 2005)

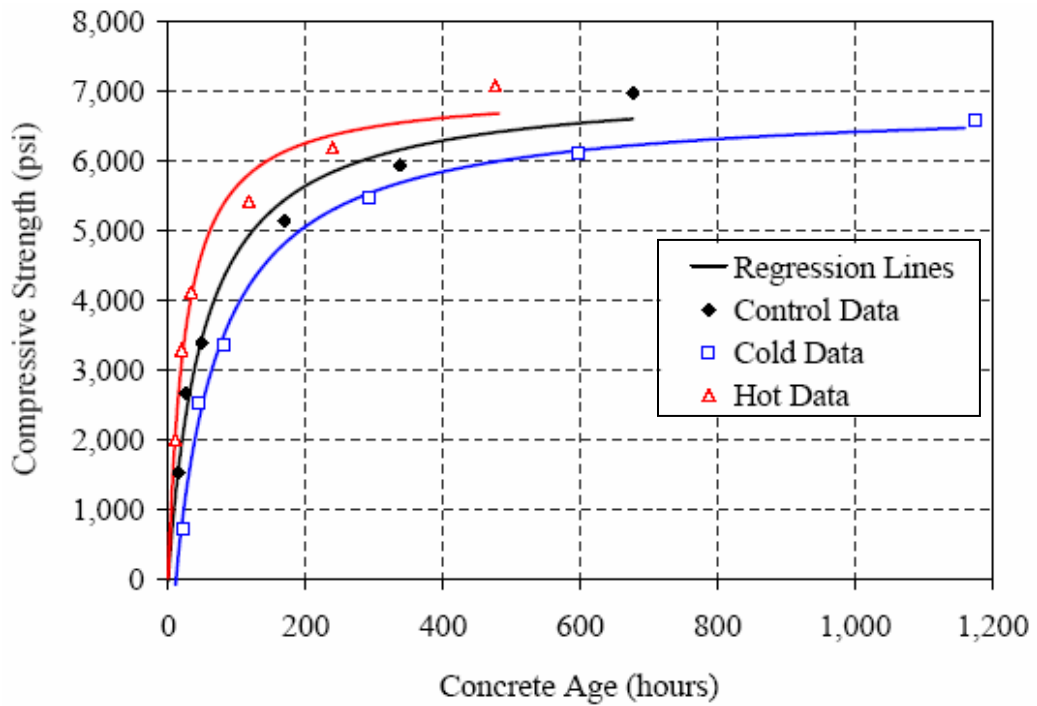

Figure 3-5: Compressive strength versus age results for 20% Class F fly ash mixture (Wade 2005)

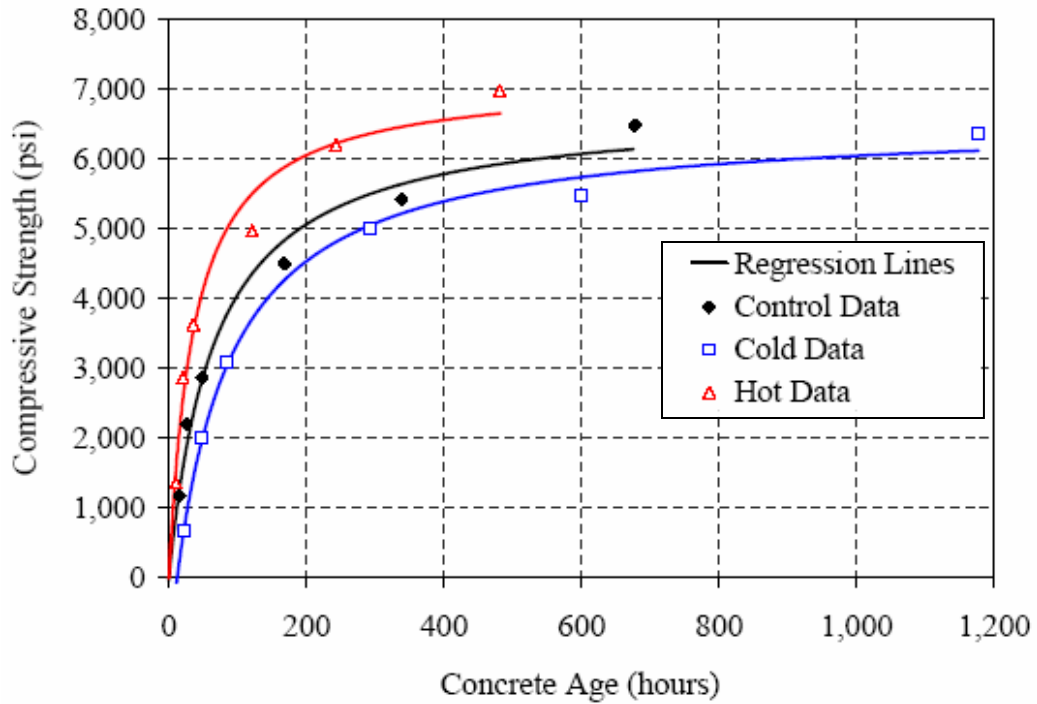

Figure 3-6: Compressive strength versus age results for 30% Class F fly ash mixture (Wade 2005)

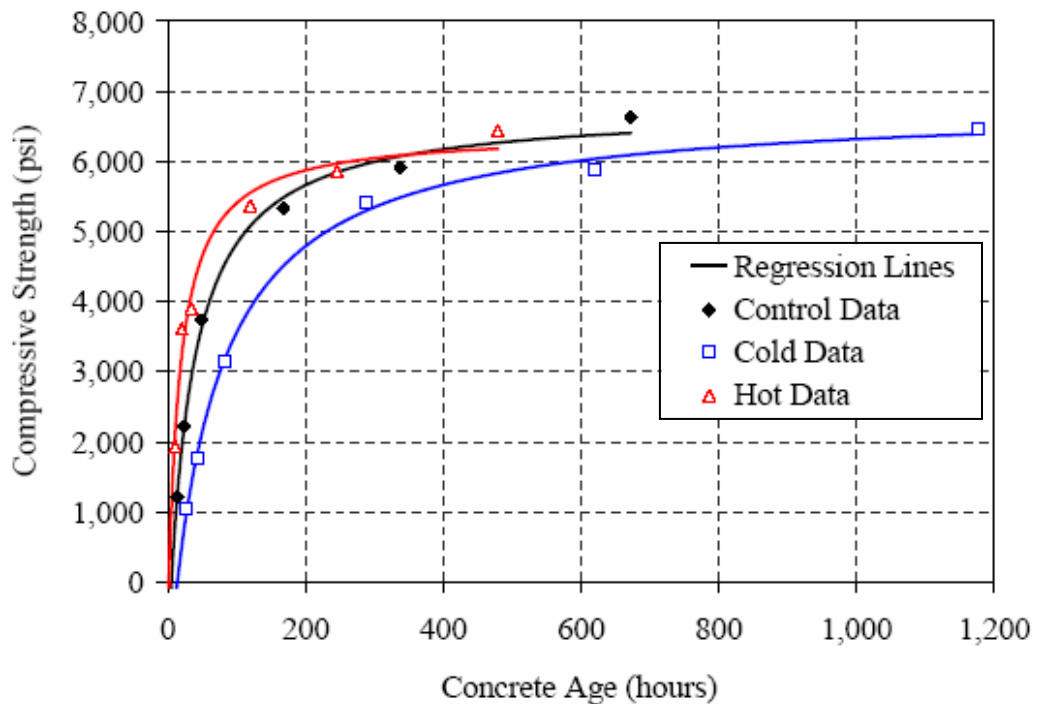

Figure 3-7: Compressive strength versus age results for 20% Class C fly ash mixture (Wade 2005)

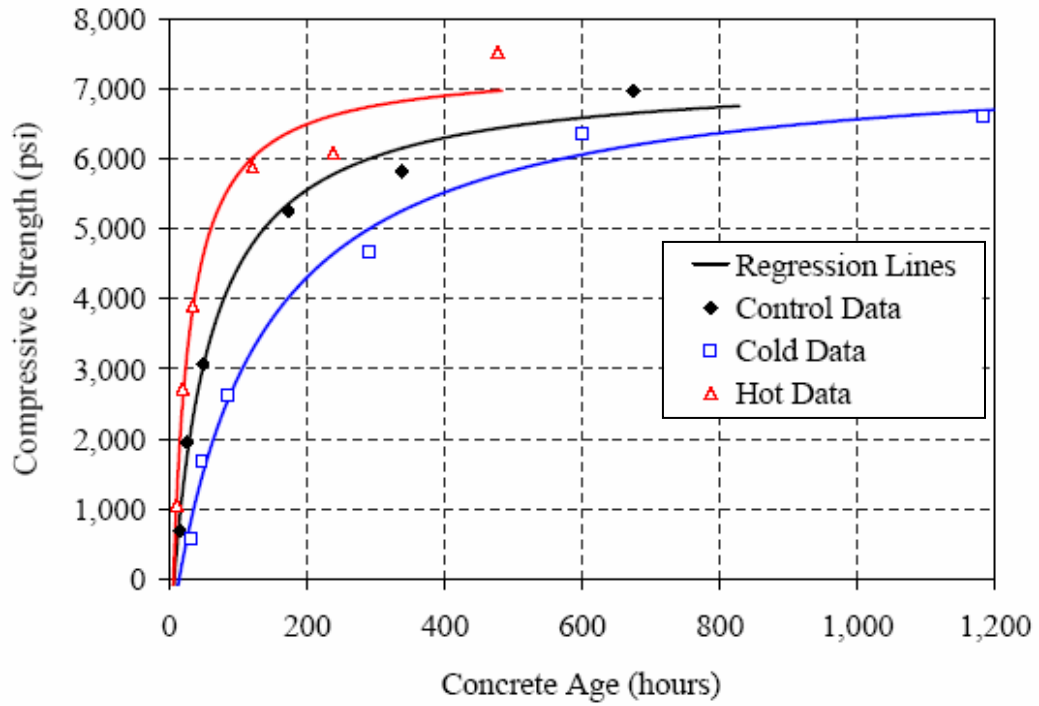

Figure 3-8: Compressive strength versus age results for 30% Class C fly ash mixture (Wade 2005)

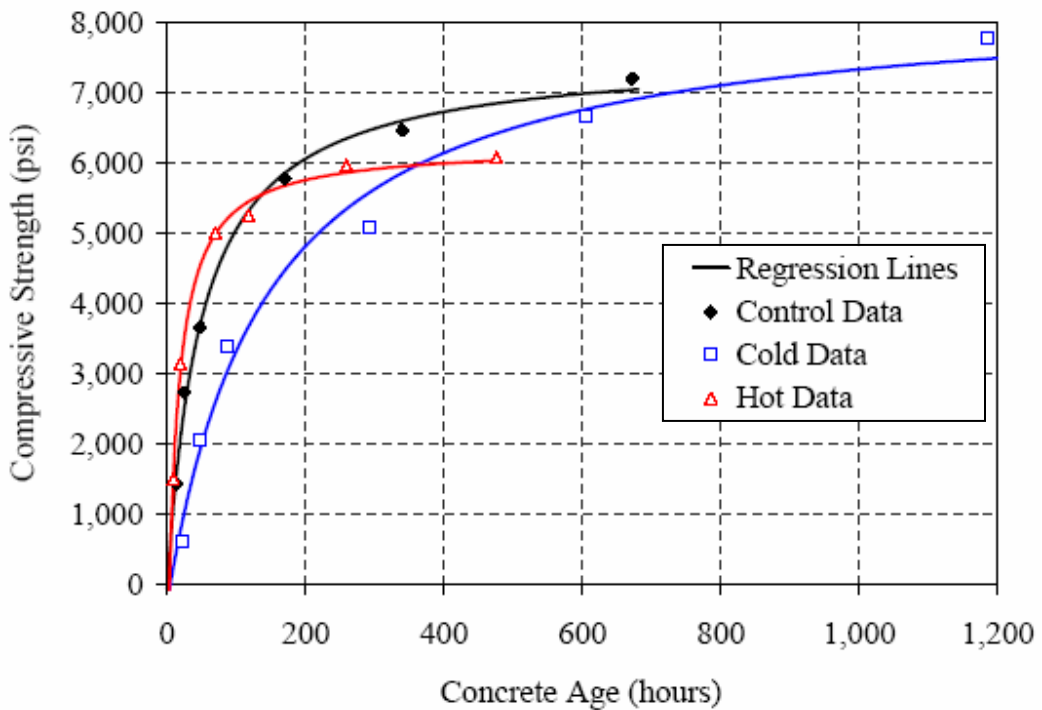

Figure 3-9: Compressive strength versus age results for 30% Slag mixture (Wade 2005)

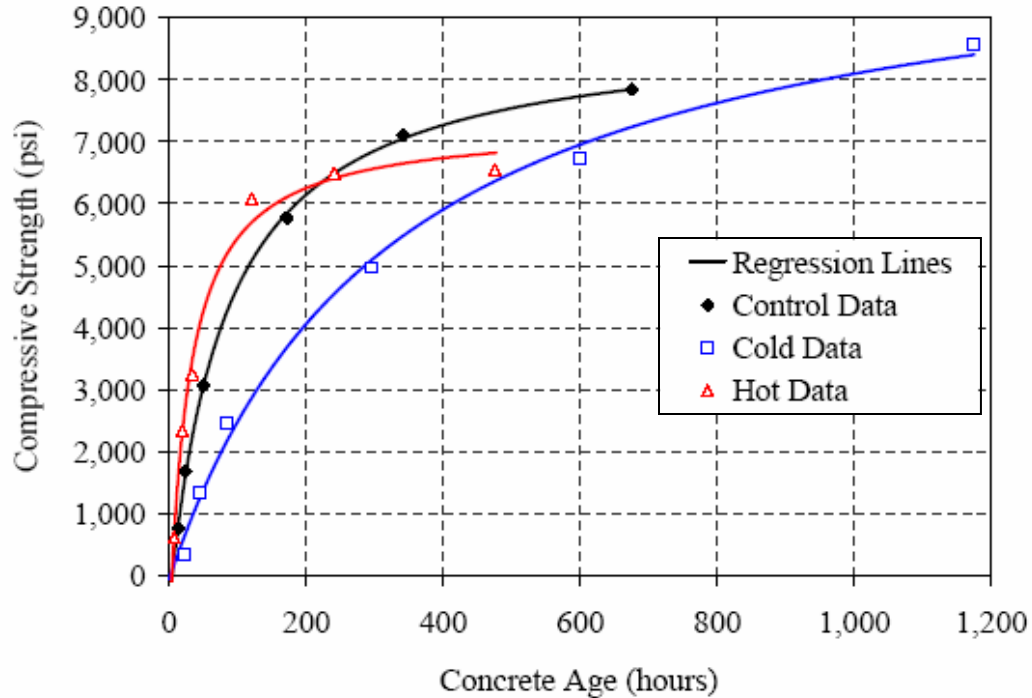

Figure 3-10: Compressive strength versus age results for 50% Slag mixture (Wade 2005)

As shown in Figure 3-3 to 3-10, each concrete mixture was affected by the different curing temperatures. If the curing temperature had not affected the strength of the concrete then only one curve would be present, not three. Some of the concrete mixtures, such as the Class F fly ash mixtures, were not affected by the crossover effect. The ultimate strengths or 28-day strengths for the Class F fly ash mixtures were approximately the same for the three curing conditions. As for the Type I and GGBF slag mixtures, the ultimate strengths decreased as the curing condition temperatures increased. The Type I – 0.48 was affected the most by the crossover effect. The 28-day strength of the cold curing condition was approximately 7,100 psi, whereas the 28-day strength of the hot curing condition was approximately 5,100 psi. The 2,000 psi difference is a large difference that the maturity method will not account for, and therefore, it was

recommended that the maturity method only be used for estimating concrete strength up to an equivalent age of 7 days.

3.4 MAJOR FINDINGS

The conclusions that were found in the laboratory phase based on the crossover effect were as follows Wade (2005):

- All hot batches tended to gain strength faster in the beginning and then some reached a reduced ultimate strength relative to batches cured at lower temperatures.
- The cold batch's strength in the beginning developed more slowly, while the ultimate strength was, for most mixtures, higher than that of the hot batch.
- All straight cement mixtures had crossover, with long-term strength losses ranging from 7% to 12% and crossover occurred between 7 days and 16 days.
- The replacement of cement with 20% and 30% Class F fly ash for the Type I - 0.41 mixture effectively eliminated the crossover effect.
- The replacement of cement with 20% Class C fly ash for the Type I - 0.41 mixture delayed, but did not completely eliminate, the crossover effect. An increased replacement dosage of 30% Class C fly ash for the Type I - 0.41 mixture effectively eliminated crossover.
- The replacement of cement with 30% or 50% GGBF slag for the Type I - 0.41 mixture increased crossover for the hot batch from 6% to more than 17% in some cases.

- Changing the cement from Type I to Type III for the Type I - 0.44 mixture increased the crossover effect slightly, but greatly decreased the time at which crossover occurred, from 16 days to 4 days.
- The replacement of cement with 20% Class F fly ash and 10% silica fume for the Type I - 0.44 mixture increased the crossover effect from 7% to 31% strength loss and increased the time at which crossover occurred from 16 days to 5 days.
- The Type III - 0.37 mixture had a 17% strength loss due to the crossover effect and crossover occurred less than two days after mixing for the hot batch.
- The ternary blend prestressed concrete mixture had a long-term strength loss of 23% from the crossover effect.

As for the accuracy of the maturity method, it was found that that the ASTM method produced average absolute percent errors in estimating strengths between 6% and 27%. These high errors were concluded to be partly attributed to the long-term strength loss associated with the hot batches. The loss in long-term strength cannot be solely corrected by the maturity method. Therefore it was recommended that the maturity method be used only until an equivalent age of 7 days.

Common constant temperature sensitivity values for both the Nurse-Saul maturity method and Arrhenius maturity method were evaluated and the conclusions reached were as follows (Wade 2005):

- When using the Nurse-Saul maturity function, a datum temperature of 0 °C (32 °F) produced less error than that found by using -10 °C (14 °F) for all mixtures.
- When using the Arrhenius maturity function, an activation energy of 40,000 J/mol for cold batches and 25,000 J/mol for hot batches produced the least error in strength estimations for 10 out of the 13 mixtures evaluated.

The final recommendations from the analysis of the laboratory phase are as follows (Wade 2005):

- Strength estimations using the maturity method may not be accurate beyond 7 days of equivalent age.
- If a mixture-specific temperature sensitivity value is desired, the Modified ASTM method should be used.
- If the Arrhenius maturity function is to be used, a temperature dependent model, such as that suggested by Freiesleben Hansen and Pederson (1977), described in Section 2.3.3, that allows for a high temperature sensitivity value at low temperatures and a lower value at high temperatures should be used.
- The Nurse-Saul maturity function using a constant value of 0 °C (32 °F) as the datum temperature should be used if a mixture-specific value is not determined.
- Results for mixtures in this study suggested that, in hot climates, when using Class F or Class C fly ash as replacement cement, for doses of 20 to 30%, a datum temperature of 4 °C (40 °F) or greater should be used.

3.5 SUMMARY

Wade (2005) concluded that the Nurse-Saul maturity function with a datum temperature of 0 °C (32 °F) provides a good means of estimating the strength of concrete for different cement types, varying types and dosages of supplementary cementing materials, and varying water-to-cementitious materials ratios when it is cured under fluctuating temperatures. The testing schedules used for the “hot” and “cold” curing conditions were sufficient for capturing the strength development of the concrete.

CHAPTER 4

**EVALUATION OF THE MATURITY METHOD FOR
PRECAST/PRESTRESSED CONCRETE OPERATIONS**

The accuracy of the maturity method for use in precast prestressed concrete applications will be evaluated in this chapter. Actual construction processes used to construct full-scale prestressed girders were used for this evaluation. Preparation for field testing was conducted at Auburn University, but field testing was conducted at the Sherman Prestress Plant in Pelham, Alabama. The field testing portion of this project was conducted in August 2004.

4.1 EXPERIMENTAL DESIGN

Multiple objectives were identified for the prestressed girder project. The main objective was to determine the accuracy of the maturity method to estimate in-place strengths in a precast prestressed application. The second objective was to evaluate the cylinder curing condition best suited for simulating the girder curing history. In conjunction with evaluation of the best curing condition, it was necessary to develop a cylinder testing schedule for developing the strength-maturity relationship for prestressed concrete mixtures. Finally, the most appropriate location for temperature sensors used to measure the maturity of the girder had to determine.

4.1.1 ANALYSIS APPROACH

Three test methods were used to evaluate the accuracy of the strength estimated by the maturity method. These test methods were: (1) compression testing of molded concrete cylinders cured under multiple conditions, (2) pullout testing, and (3) compression testing of cores extracted from the member. All in-place tests were performed on a mock girder, which was constructed using the same methods typically used to manufacture ALDOT girders. Figure 4-1 shows types of testing used for the prestressed girder project.

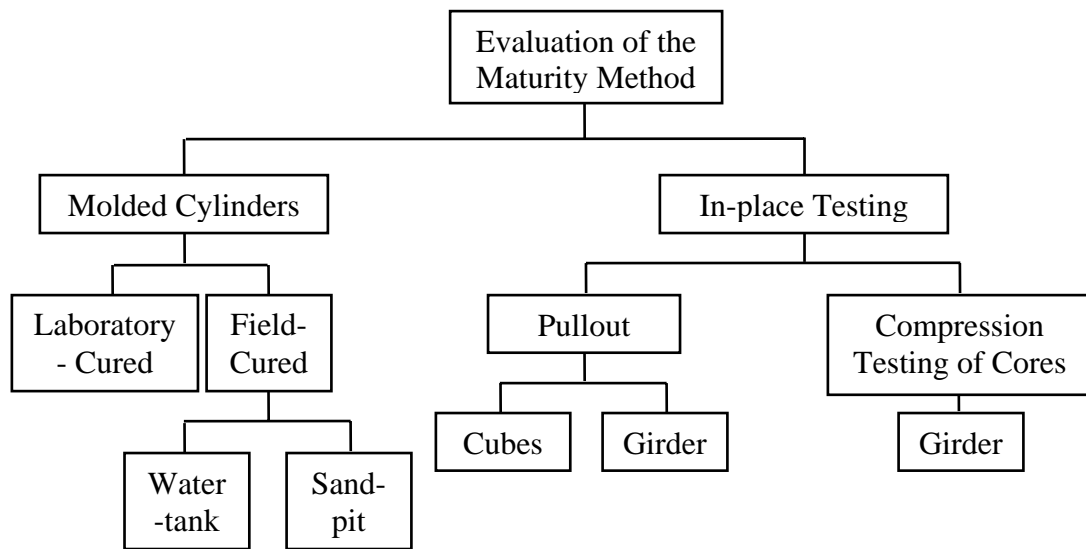

Figure 4-1: Testing performed for the prestressed concrete plant

4.1.1.1 Molded Cylinders Strategy

Different curing methods were used for the molded cylinders to establish the strength-maturity (S-M) relationship. One set of cylinders were cured in accordance with AASHTO T 23 (2004), where the curing temperature was controlled to be $73\text{ }^{\circ}\text{F} \pm 3\text{ }^{\circ}\text{F}$. The field-cured specimens were designed to mimic the temperature history of the girder, to try to eliminate discrepancies that can result with curing concrete under laboratory

conditions while concrete in the girder is cured under field conditions. Problems could include the crossover effect discussed in Section 2.5.1 and 3.3. A lime-saturated water-tank and damp-sand-pit were used to field-cure some of the molded cylinders. Each curing method was evaluated to determine which one best mimics the temperature history of the actual girder, which would then allow the cylinders to exhibit strengths close to the girder concrete.

All the strength and temperature data obtained from the different cylinder curing methods were used to develop different S-M relationships as explained in ASTM C 1074 (2004). The Nurse-Saul (Equation 2-1) and Arrhenius (Equation 2-2) maturity functions were used to calculate the maturity indices. ASTM C 1074 (2004) recommends a datum temperature of 0 °C be used for the Nurse-Saul maturity function. TxDOT (Tex-426-A 2004) and Iowa DOT (IM 383 2004) use a datum temperature of -10 °C (14 °F), which will be further discussed in Section 6.1. Therefore, datum temperatures of 0 °C (32 °F) and -10 °C (14 °F) were evaluated. ASTM C 1074 (2004) also recommends that if the Arrhenius maturity function is used, the activation energy be set as a range from 40,000 to 45,000 J/mol. As recommended by Freiesleben Hansen and Pederson (1977) (in Section 2.3.3), Europeans use an activation energy value as low as 33,500 J/mol for concrete cured above 20 °C (70 °F). Activation energies of 33,500 J/mol and 40,000 J/mol were selected to compute the Arrhenius maturity function for the prestressed girder project.

The use of confidence levels for prestressed applications was also considered. As stated previously in Section 2.8.1, confidence levels are a means of ensuring that for critical construction operations, the required strength is met before proceeding with

subsequent construction operations. The strength criteria stated in ACI 318 (2005) Section 5.6.3.3 allows for 10% of test results to fall below f'_c ; therefore, a one-sided tolerance with defect level of 10% was used to estimate strengths of the concrete at various confidence levels. The use of 10% defect level ensures that 90% of the population of strengths will remain above the strength estimated from the strength-maturity relationship. For the prestressed girder project, confidence levels (γ) equal to 50%, 75%, and 90% were considered. Confidence levels were used to predict in-place strengths based on S-M relationships developed from laboratory-cured and field-cured cylinder specimens.

4.1.1.2 In-Place Strength Strategy

Once the accuracy of the maturity method was evaluated based on cylinders cured under different conditions, the in-place strength was evaluated. In-place testing was conducted because concrete cured under control conditions, such as laboratory-cured cylinders and field-cured cylinders, does not always provide a true representation of the actual in-place concrete strength. Concrete placed in the field experiences different temperature conditions, moisture conditions, and consolidation than that cured under controlled conditions; therefore, testing that is conducted on concrete placed in the field would be expected to provide a more accurate assessment of the in-place strength. For this project, two methods were used to determine the in-place strength of the girder: the pullout test and compressive testing of cores. Since the two test methods used to test the in-place strength were destructive methods, a mock prestressed girder was cast.

Before the pullout test could be used to assess the in-place strength, the pullout strength table (Appendix A) for the test apparatus had to be verified. Once the pullout table was proven accurate, then the pullout test can was used to assess the in-place strength. Results for each of the two test methods used to assess the in-place strength were compared to the strengths estimated from the laboratory-cured and field-cured strength-maturity relationships. Initially, only the pullout test was going to be performed because the pullout test is considered one of the more accurate methods to assess the in-place concrete strength (Carino 1997, Bungey and Soutsos 2000, Kierkegaard-Hansen and Bickley 1978, Hubler 1982, and Malhotra and Carette 1980). Cores were originally not considered for testing because of the uncertainties inherent in this testing method, which were discussed in Section 2.8.3. However, the test method used by ALDOT for assessing the in-place strength is to test cores extracted from the structure. Therefore, compressive testing of cores was added to the testing matrix.

4.1.2 LAYOUT OF TESTS

Multiple factors were considered in selecting the tests for a prestressed girder application. The final testing procedures are described in Section 4.3.

4.1.2.1 Development of the Strength-Maturity Relationship

In developing the S-M relationships, curing conditions and testing schedules were considered. Since the temperature history of the laboratory-cured and field-cured cylinders would be significantly different, two different testing schedules were developed. First, the field testing schedule was established. Testing times were designed

to capture the rapid early-age strength development of prestressed concrete due to the use of Type III cement and steam curing. The test schedule used for the field-cured specimens was to test at concrete age of 8 hours, 12 hours, 18 hours, 24 hours, 48 hours, 4 days, 7 days, and 28 days. At the prestress plant, most of the forms are removed at a concrete age of approximately 18 hours. However, before releasing the strands, the quality control personnel will test the strength of the concrete by compression testing molded cylinders before releasing the strands. Once the concrete has reached the desired strength, the forms are removed and the strands are cut. Therefore, the testing conducted at 18 hours is intended to ensure that the concrete has reached the required strength to resist the stresses due to the transfer of prestress force.

Once the field-cured specimens' test schedule had been developed, the test schedule for the laboratory-cured specimens was developed by using the age conversion factor discussed in Section 2.3.1. An idealized temperature profile based on a typical temperature history used to cure prestressed members was selected (Figure 4-2), and the equivalent age was determined with this temperature history.

The Nurse-Saul method was used with a datum temperature of -10°C (14°F) to develop the testing schedule. The target testing schedule for the laboratory-cured specimen was to test at concrete ages of 11 hours, 20 hours, 34 hours, 42 hours, 66 hours, 4 days, 7 days, and 28 days. Test ages of 4 days, 7 days, and 28 days were actually supposed to be 0.7 days later, but since the testing times are not as critical at these ages, these specimens were tested at the same time as the field-cured specimens.

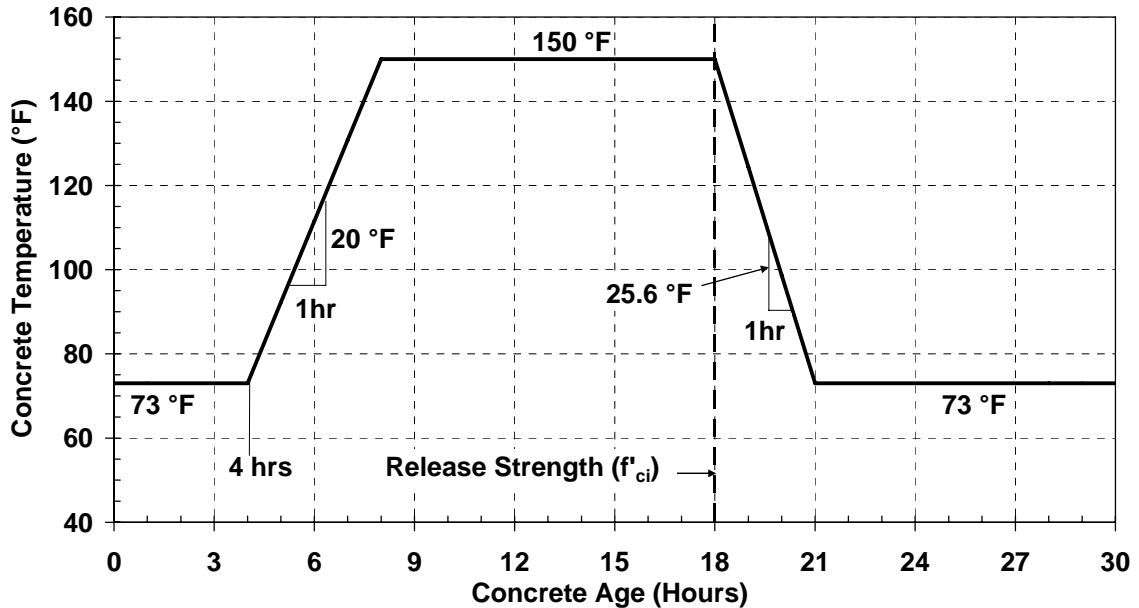

Figure 4-2: Assumed temperature profile for prestressed girder

4.1.2.2 Girder Design

Two main factors were initially considered when the geometry of the mock girder was designed. First was the necessity that the girder type be the same as one that ALDOT uses in actual construction. ALDOT commonly uses AASHTO and Bulb-Tee girders. The second factor was that Sherman prestress had some existing twenty-foot AASHTO Type IV forms that could be used for the project. These forms were selected as they were older forms that were not being used anymore and they could be modified for this research project.

Once the type of girder was established, the layout of the testing location was designed. Multiple tests had to be conducted on the girder to establish the in-place strength of the concrete, including temperature recording, pullout testing, and coring. Each type of test required that the test location be carefully placed. No testing was

conducted within 18 inches of the ends of the girder to eliminate problems that could occur with concrete near the ends of the girder. Based on these constraints, the mock girder was 19 foot long AASHTO Type IV girder.

The structural behavior of the mock prestressed girder was considered. No live loads would be applied to the mock girder; therefore all design was done using dead loads along with loads that might be encountered during transportation of the mock girder from the steam beds to the storage yard. Minimum longitudinal steel reinforcement requirements were met, and some steel was added to anchor the corners of the stirrups during construction. In addition, two lightly stressed 0.6-inch prestressing strands were used in the web of the mock girder to help position the stirrups as shown in Figure 4-3. Minimum stirrups were adequate for the mock girder; therefore, the stirrups were positioned so as to not interfere with the in-place tests. The longitudinal and transverse reinforcement placed in the mock girder are shown in Figure 4-3 and Figure 4-4.

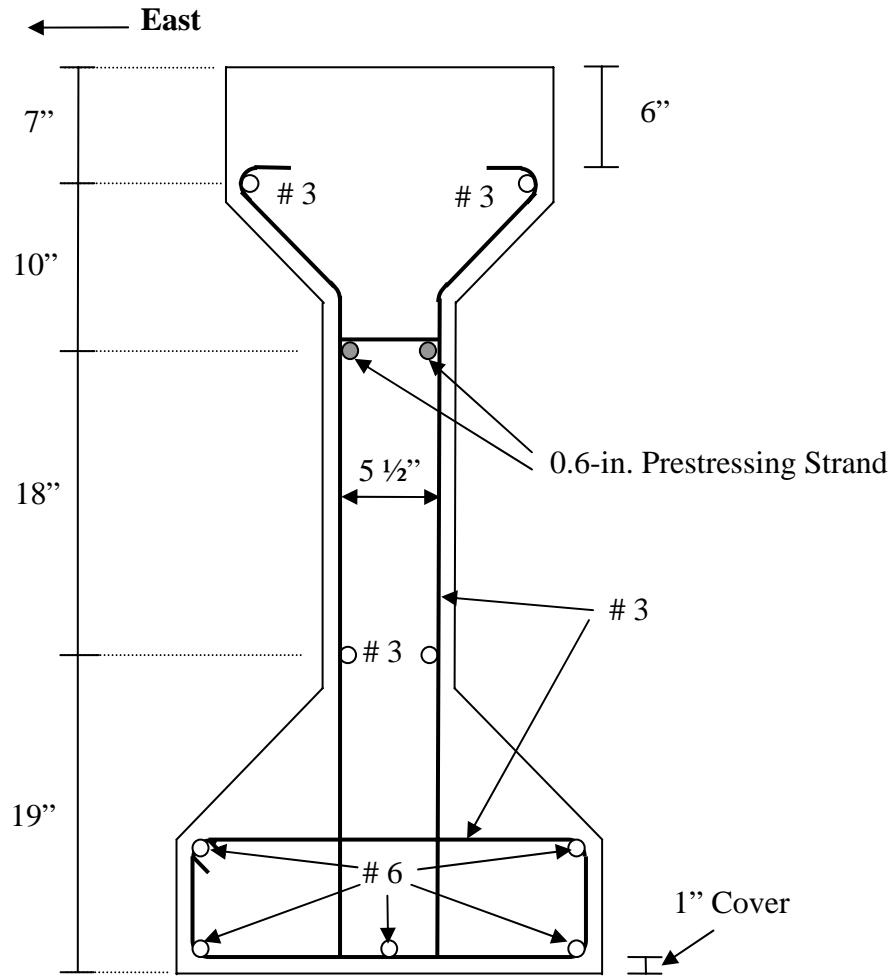

Figure 4-3: Cross-sectional reinforcement configuration for mock girder

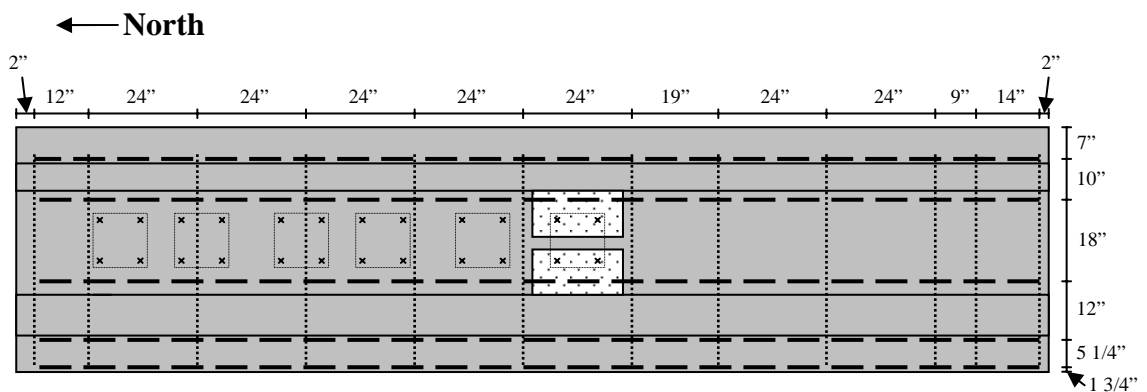

Figure 4-4: Side view of formwork, steel reinforcement, and access panels

For the cored specimens a length-to-diameter (L/D) ratio of 2 was desired so that no correction factors would need to be applied, and the cores would have the same L/D as the molded concrete cylinders. Cores were taken out of the top flange of the girder, because this was the only place on the girder that a core could be obtained with an adequate length. Since the top flange was small, core tests were performed at 7 and 28 days. Two different curing methods, ASTM C 42 (2004) and AASHTO T 24 (2002), were used to condition the cores after they were extracted from the girder. Twelve cores were removed at each age. Two of the cores were used for temperature recording and the other ten were strength tested, five each for the two curing methods. The layout of the cores can be seen in Figure 4-5.

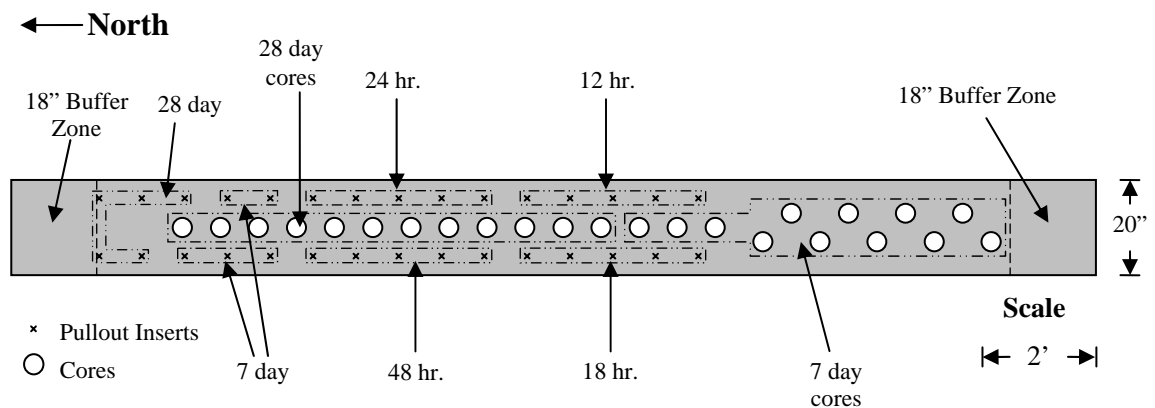

Figure 4-5: Plan view of mock girder

Pullout testing locations were determined after the location of the cores was finalized. Pullout tests were performed on the top and side of the girder. Five inserts were tested at each age on the top, as this is the minimum required by ASTM C 900 (2004). The layout of the top inserts can be found in Figure 4-5. Since there was plenty of room on the side of the girder, four inserts on each side for each age were used. The layout of

the side inserts can be seen in Figure 4-6. The pullout testing ages corresponded with a most of the field-cured cylinder testing schedule. The testing ages were 12 hours, 18 hours, 24 hours, 48 hours, 7 days, and 28 days. In order to perform the 12-hour pullout tests, an access panel was installed in the forms to allow access for the tests to be performed before the forms were removed.

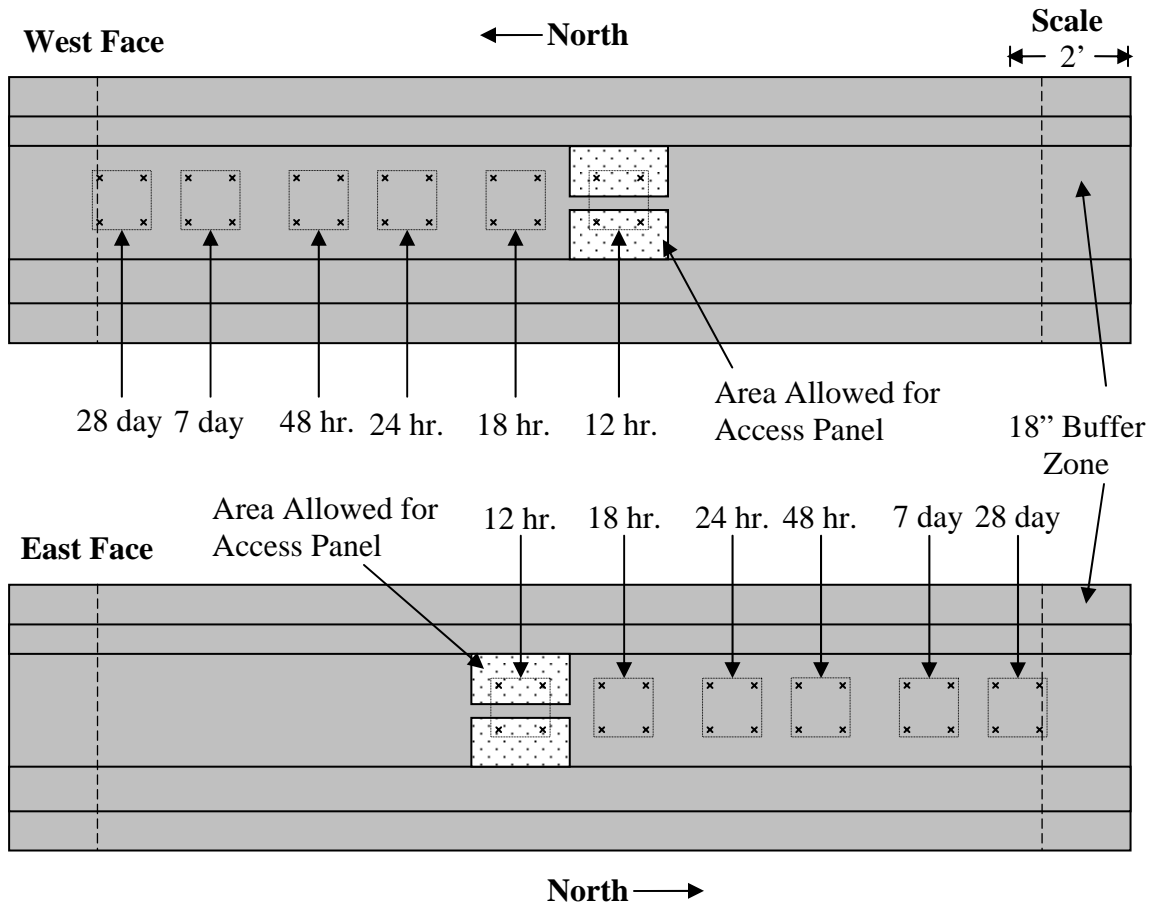

Figure 4-6: Elevation views of mock girder

The temperature sensor layout was designed so that the temperature profile of the girder at critical points and at each in-place testing location could be measured. The location of all of the iButton temperature sensors can be seen in Figure 4-7. The

temperature sensors were attached to the stirrups throughout the beam. A total of 7 iButton trees were made. The term “Tree” refers to multiple iButtons attached in series at a single cross-section. Trees 1 and 7 had nine iButtons, Trees 2 and 3 had six iButtons, Tree 4 had ten iButtons, and Trees 5 and 6 had three iButtons.

Trees 1, 4, and 7 were designed to determine the location of the maximum and minimum temperatures in the girder. The assumption was made that the temperature would be symmetrical about the vertical axis. Location A and C sensors were used for the top inserts, and location D was used for the cores. Side inserts used the sensors at either location E or G. Locations D and F were used to compare the temperature gradient from the center to edge of the web.

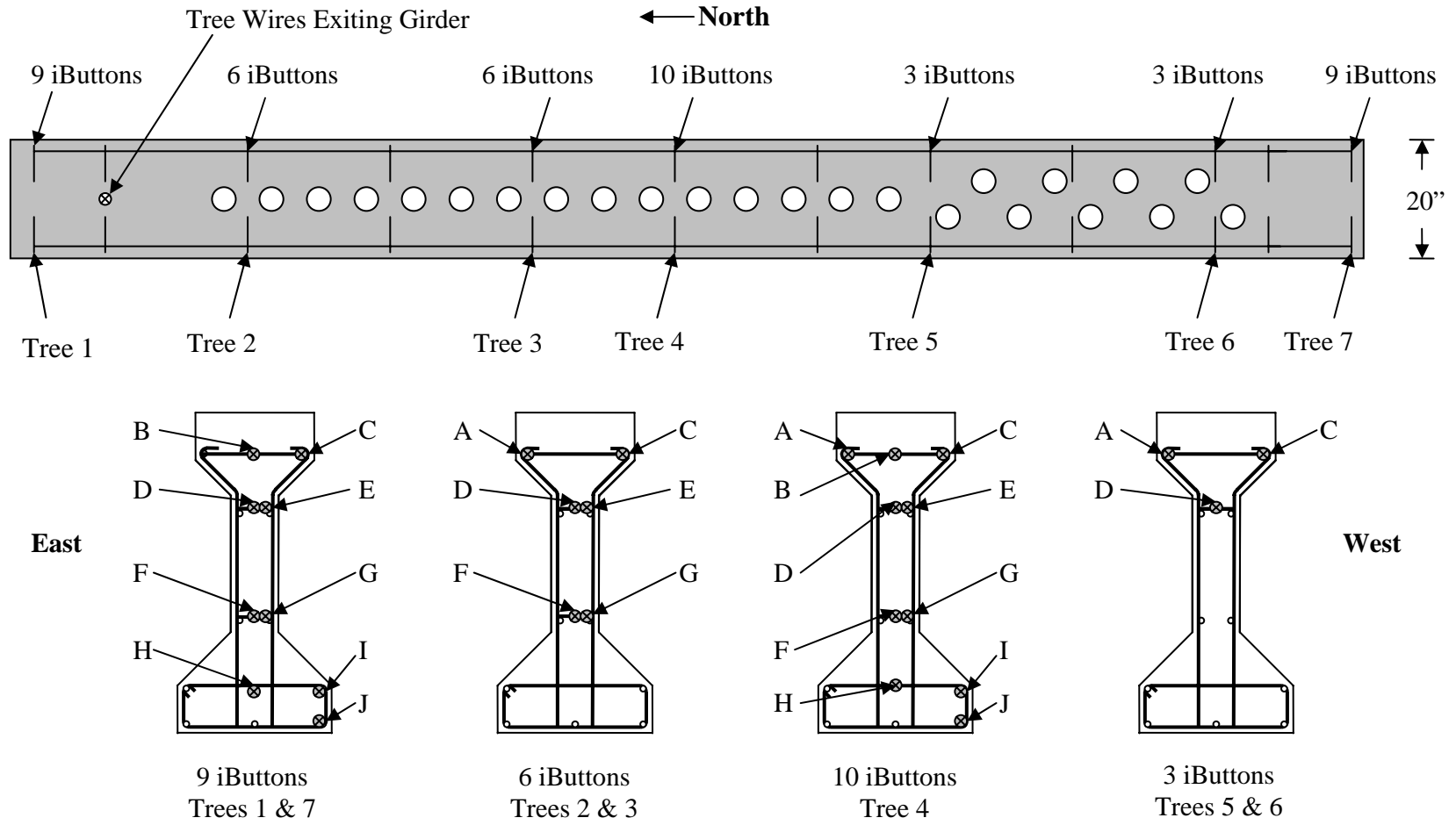

Figure 4-7: iButton Tree layout

4.1.2.3 Verification of Pullout Table

For the pullout machine supplied by Germann Instruments, a table (Appendix A) was provided that correlated the pullout force to the compressive strength of a 6 x 12 inch cylinder. A series of tests was conducted to confirm that the correlation table was accurate. As stated in Section 2.8.2.5, there are two different methods to verify or create pullout load-to-compressive strength relationships. Cubes (8 x 8 x 8 in.) were used to verify the correlation between the pullout force and compressive strength. Additional 6 x 12 inch cylinders were used to determine the compressive strength. Since a pullout force versus compressive strength relationship was provided by Germann Instruments, tests at three ages (instead of the ACI recommended six ages) were used to verify this that relationship was sufficiently accurate. The average compressive strength of the pullout test obtained from pullout force versus compressive strength table was compared to the estimated strength from the S-M relationship of the cylinders that were cast along with the cubes. If the compressive strengths measured from the pullout tests performed on the cubes were relatively close to the compressive strengths measured from the cylinders cured in the water-tank, with both at the same maturity, then the pullout table were considered accurate. Test at three different ages were conducted: 18 hours, 48 hours, and 7 days. Six cubes were cast, and two cubes (8 inserts) were tested at each age. The cubes were cured the same way as the lime-saturated water-tank cylinders.

4.2 RAW MATERIALS AND MIXTURE PROPORTIONS

All material used to produce the concrete was supplied by Sherman Industries. The mixture design used was one that is commonly used for the production of prestressed

girders. Sherman produced the concrete and cast the mock girder using construction procedures typically used for ALDOT prestressed girders. The concrete used for the research was mixed on site at Sherman's batch plant (Figure 4-8). All concrete was made in one 5-yd³ batch to eliminate variations that can occur from batch-to-batch. Table 4-1 contains the mixture proportions for one cubic yard of the concrete and the required fresh and hardened concrete properties. All coarse and fine aggregate weights are for saturated, surface-dry condition.



Figure 4-8: Sherman's batch plant

Table 4-1: Mock girder mixture proportions

Item	Mixture Design
Water (pcy)	260
Type III Cement (pcy)	705
Coarse aggregate (pcy)	1,983
Fine aggregate (pcy)	1,125
Air-Entraining Admixture* (oz/yd)	1.6
High-Range Water Reducing Admixture ⁺ (oz/yd)	56.4
Target air (%)	4 (± 1)
Target slump (in.)	8 (± 1)
w/c	0.34
f _c (psi)	7,000

* Degussa Inc., MBVR

⁺ Degussa, Inc., Glenium 3200 HES

The Type III cement was obtained from Cemex and was produced at the plant in Demopolis, AL. The coarse aggregate was a No. 78 crushed limestone from Vulcan Materials in Helena, AL. The fine aggregate was obtained from Superior Products quarry located in Red Bluff, AL. Gradations of the coarse and fine aggregate used for the project were not obtained, but specific gravities for the materials are listed in Table 4-2. The air-entraining admixture was MBVR, and the high-range water-reducing admixture was Glenium 3200 HES.

Table 4-2: Material properties for prestressed girder project

Materials Description	Specific Gravity	Absorption (%)
Water	1.00	-
Type III Cement	3.15	-
Coarse aggregate	2.82	0.4
Fine aggregate	2.62	0.4

4.3 FIELD PROCEDURES AND TESTING

This section documents all of the testing procedures that were used for the tests conducted for the prestressed girder project.

4.3.1 FRESH CONCRETE TESTING

Fresh concrete properties were measured to ensure that the concrete that was supplied for the research met ALDOT specifications. All fresh concrete tests were conducted or overseen by an ACI Concrete Field Testing Technician – Grade I.

4.3.1.1 Quality Control Testing

The quality control tests conducted for the prestressed plant project included slump, air content, and fresh concrete temperature. All fresh concrete properties were tested in accordance with AASHTO Specifications: slump – AASHTO T 119 (2005), air content – AASHTO T 152 (2005), and fresh concrete temperature – AASHTO T 309 (2005).

4.3.1.2 Making and Curing of Specimens

Concrete for the laboratory-cured cylinders, field-cured cylinders, and pullout cubes was taken from the middle of the batch as specified in AASHTO T 141 (2005). All specimens were cast with the same concrete that was placed in the girder and then moved to the different curing conditions at appropriate times. The specimens were cast on the steel casting bed to ensure that a hard flat surface was used, as shown in Figure 4-9.



Figure 4-9: Casting of concrete specimens

A total of 58 - 6 x 12 in. white plastic cylinder molds were used for the laboratory-cured and field-cured cylinders. All cylinders were made in accordance with AASHTO T 23 (2004). Once the specimens were made and the plastic lids snapped on, the 25 laboratory-cured cylinders were placed in field-curing boxes for the first 24 to 48 hours. These field-curing boxes maintained a curing temperatures between 60 and 80 °F (15.6 to 26.7 °C). After 24 hours, the cylinders were transported to Auburn University,

removed from the plastic molds, and placed in a moist-curing room in which the temperature was held at $73\text{ }^{\circ}\text{F} \pm 3\text{ }^{\circ}\text{F}$, and the relative humidity was maintained at 100%. Three cylinders were tested at each age. One extra cylinder was instrumented with a temperature sensor to measure the concrete's temperature history. As discussed in Section 4.1.2.1, the testing ages for the laboratory-cured cylinders were 11 hours, 20 hours, 34 hours, 42 hours, 66 hours, 4 days, 7 days, and 28 days.

The remaining 33 cylinders were field-cured to allow evaluation of the effects that elevated temperatures had on the strength of these cylinders. All of these remaining cylinders were placed on the bed used for the mock girder and then covered with curing tarps used for prestressed girders, as shown in Figure 4-10.

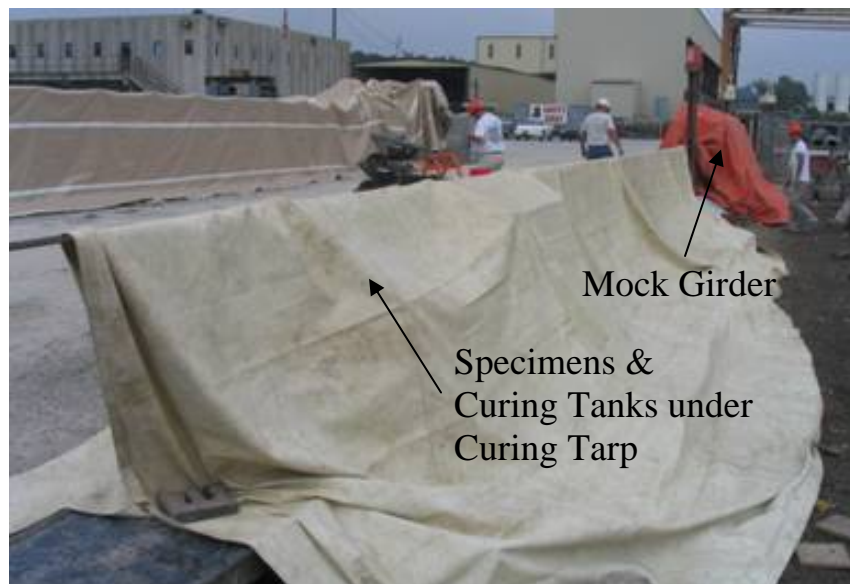

Figure 4-10: Curing tarp over the specimens and mock girder

The water-tank and sand-pit were both underneath the curing tarp so that the two containers would also be heated along with the girder. This was done so that when the cylinders were moved to the two containers, there would not be a dramatic change in

temperature. The tarps were removed and the forms on the mock girder were removed at a concrete age of approximately 18 hours. Next, the field-cured specimens were removed from the plastic molds and placed in the two separate curing environments. Half of the cylinders were moved to each field-curing condition. The lime-saturated water-tank can be seen in Figure 4-11, and the damp-sand-pit can be seen in Figure 4-12.



Figure 4-11: Lime-saturated water-tank



Figure 4-12: Damp-sand-pit

When the girder was removed from the prestressing bed, the water-tank and sand-pit were moved with the girder to the storage yard that was exposed to the environment. Again, three cylinders from each curing condition were tested at each age, and one additional cylinder was instrumented with a temperature sensor to measure its temperature history. The testing ages for the field-cured cylinders were 8, 12, 18, 24, and 48 hours, and 4, 7, and 28 days. Since all field specimens were cured under the tarp for the first 18 hours, one set of three cylinders was tested at 8, 12, and 18 hours, and the results were used for both sets of field-cured cylinders (water-tank and sand-pit cured).

The final specimens that were made were the pullout cubes. Since no standard exists detailing pullout cube construction, previous research and recommendations were applied. As stated by Carino (1997), an 8-inch cube with 1 inserts on each of the 4 faces is the preferred approach to eliminate any problems that can occur with radial cracking in the cylinders, which was discussed in Section 2.8.2.5. Therefore, six cube molds were designed to create an 8-inch cube with one insert in the center of each vertical side. The molds were made out of wood, sealed with polyurethane, and coated with a form-releasing agent so the concrete would not stick to the mold. Figure 4-13 shows the pullout molds.

No information is given on the method for properly consolidating the fresh concrete in the cubes, so a standard procedure was developed for these cubes. The standard for making concrete cylinders (AASHTO T 23 2004) was used in developing the standard for making the pullout cubes. Cylinders are filled in three layers for 6 x 12 inch cylinders, so this scheme was used for the cubes. As for the number of rods per layer, cylinders are rodded 25 times per layer. The area of a 6-inch cylinder is 28.27

inches; therefore the number of rods was calculated as 0.884 rods per in². Then the ratio of rods per square inch was multiplied by the area for an 8 x 8 in. surface cube (64 in²) which returned 56 roddings per layer. Finally, it is required to tap the sides of a cylinder with a mallet 12-15 times per layer and since the cube molds were made out of wood, it was decided to tap each side 4 times, giving 16 taps per layer.

After the cubes were cast, the molds were placed in double bags and sealed to prevent moisture loss from the concrete. This is equivalent to capping cylinders after they have been made. The pullout cubes were then cured under the curing tarps and finally moved to the lime-saturated water-tank at 18 hour when the girder forms were removed. Pullout tests from the cubes were performed at 18 hours, 48 hours, and 7 days.



Figure 4-13: Pullout cube molds

4.3.2 HARDENED CONCRETE TESTING

Once the concrete had set, hardened concrete testing was performed to assess the strength characteristics of the concrete. Compression testing of cores was conducted on the mock

girder and pullout tests was conducted on the molded specimens as well as on the mock girder. In addition to all of these tests, the maturities of all the specimens were also calculated from their measured temperature histories. All hardened concrete testing was performed by ACI Certified Concrete Strength Testing Technicians.

4.3.2.1 Compression Testing of Molded Cylinders

Compression testing was conducted on cylinders cured under all three types of curing conditions: laboratory-cured, lime-saturated water-tank cured, and damp-sand-pit cured.

Compression tests were performed in accordance with AASHTO T 22 (2005).

Laboratory-cured specimens were tested at Auburn University's testing labs, while the field-cured specimens were tested at the Sherman Prestress Plant's testing facilities.

Neoprene pads were used for all compression tests. Sixty durometer neoprene pads were used for testing ages up to 66 hours for the laboratory-cured specimens testing ages up to 48 hour for the field-cured specimens. For later testing ages, 70 durometer neoprene pads were used. The compressive strength rating for a 60 durometer pad is 2,500 to 7,000 psi, and the rating for 70 durometer pads is 4,000 to 12,000 psi. AASHTO T 22 (2005) requires that the load rate for a 6 inch diameter concrete cylinder be in the range of 34,000 to 85,000 lbs per minute; therefore, to stay consistent throughout all tests, a load rate of 60,000 lbs per minute was used.

4.3.2.2 Pullout Cube Testing

All tests involving pullout cubes were conducted in accordance with ASTM C 900 (2001). Inserts that were installed in the pullout cubes were LOK-TEST inserts L-46,

which are designed for pullout loads between 0 and 100 kN, allowing compression strengths between 0 and 11,000 psi to be tested. A hole was drilled through the side of the mold to allow a screw to pass through and attach to the stem of the insert. The load rate that was used for the pullout test was 0.5 ± 0.2 kN/sec (112 ± 45 lbf/sec), which is the load rate recommended by ASTM C 900 (2001) for the inserts.

4.3.3 TEMPERATURE RECORDING

Multiple temperature-recording devices for concreting applications are commercially available. Since the temperature history for more than 50 different locations needed to be collected, a temperature-recording device called an iButton was chosen for the project. An iButton, which is shown in Figure 4-14 and is produced by Dallas Semiconductor (Maxim), allows the user to program the temperature-logging interval and starting time by means of a computer. In addition, each iButton has a serial number assigned for identification purposes. Each iButton is covered by concrete, which protects it from the harsh construction environment.



Figure 4-14: A typical iButton

The iButton does not have to be connected to a computer at all times. When the temperature data are needed, a laptop computer or hand-held computer can be attached to retrieve the data.

4.3.3.2 Temperature Recording for Cylinders and Pullout Cubes

In order to place the iButton in the concrete, wires were attached to the iButton so that the data could be retrieved later, as shown in Figure 4-15. A two-wire 20 gauge telephone wire was attached to the iButton with aluminum tape. One wire was attached to the top (labeled side) of the iButton. The other wire was attached to the bottom of the iButton. The aluminum tape on the top could not touch the sides of the iButton; otherwise, a short circuit would develop and the data could not be retrieved. On the other end of the wire, an RJ11 telephone jack was installed. Using a COM port on the computer, the phone jack was connected to the universal 1-wire COM port adapter, and all the temperature data downloaded to the computer. Once the phone jack and iButton were installed, the iButton end was coated three times with Plasti Dip, which is a liquid rubber coating. When dry, this coating provided a waterproof barrier for the iButton (Figure 4-15).

The time interval programmed in the iButton for the cylinders was 25 minutes. This allowed the iButton to record temperatures every 25 minutes over 30 days. A shorter interval was used for the cubes because testing ended after 7 days. For the pullout cubes, the time interval was 15 minutes. To eliminate any effects that iButtons could have on the strength of the cylinder, none of the cylinders containing iButtons were tested. One iButton was installed in the 7-day pullout cube, but the iButton was placed in the center of the cube so that the iButton would not interfere with the pullout inserts.



Figure 4-15: Cylinder and cube temperature-recording device

4.3.3.3 Temperature Recording for Mock Girder

The temperature sensors used for the girder were similar to the sensors made for the cylinder. The iButtons were attached to telephone wire in the same manner, but instead of using Plasti Dip, an epoxy was used in anticipation that the hydrostatic pressure from the fresh concrete could become too large and destroy the connection to the iButton sensors. The epoxy used was Sherman Williams Tile-Clad HS. Instead of using a wire and telephone jack for every iButton, iButton trees were made to allow multiple iButtons to be accessed from a single phone jack. The term “tree” will be used to refer to multiple iButtons connected to one phone jack. A total of seven iButton trees were made, and each tree was attached to a stirrup. Lead wires for each tree were made long enough so that all seven wires could come out of the mock girder at the same location. Figure 4-16 shows part of an iButton tree. Once all the trees were made, the serial number for each iButton and its location was recorded for identification purposes after the concrete was placed.

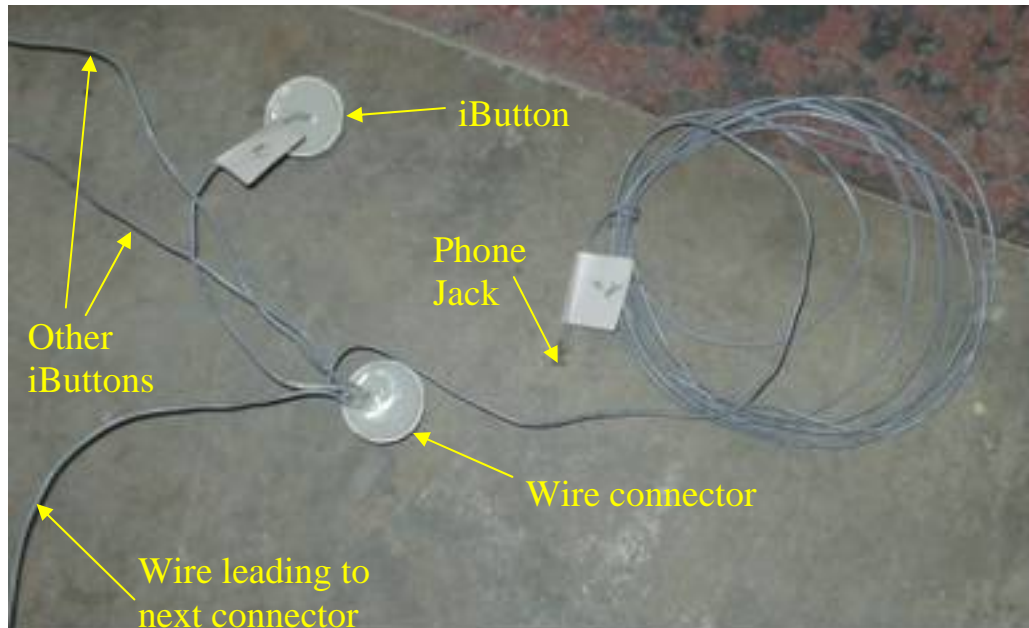

Figure 4-16: iButton tree

The time interval programmed into the iButtons used for the mock girder was 25 minutes, which allowed the iButtons to record data for more than 30 days. When an iButton was attached to a stirrup, a small foam pad was secured between the iButton and the steel to prevent the temperature of the steel from affecting the temperature recorded by the iButton (Figure 4-17).



Figure 4-17: iButton attached to a stirrup

All of the wiring was secured to the steel in an attempt to prevent the wire from being damaged while the concrete was being placed. Figure 4-18 shows iButton Tree 4 attached to the stirrups and the exit point for all the lead wires with the phone jacks for each iButton tree.

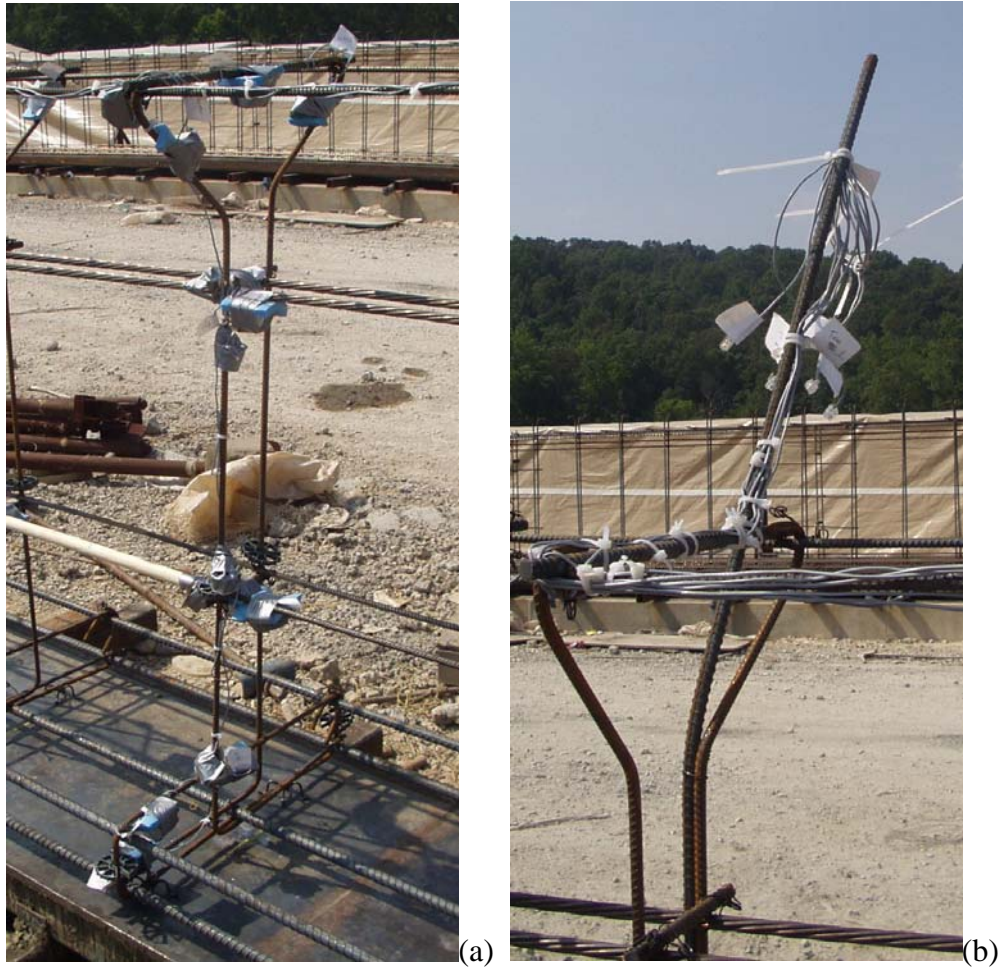

Figure 4-18: (a) iButton Tree 4 installed on a stirrup and
(b) Lead wires with phone jacks

4.3.3.4 Temperature Recording for Cores

Temperature recording for the cores was achieved with a combination of the methods used for the mock girder and cylinders. Up to time the cores were removed, the temperature history was read from the sensor installed inside the girder. After the cores were removed at each testing age, a sensor was installed into two of the cores to record the further maturing of the cores until they were strength tested. A hole was drilled into the core and an iButton was secured to the center of the core with rapid setting cement. The cores with iButtons were not strength tested.

4.3.3.5 Air Temperature Data

Ambient temperature data were required for the period over which this project was conducted. The climate data were retrieved from the National Oceanic and Atmospheric Administration (NOAA) website for the Birmingham Municipal Airport station, which is the closest NOAA recording station to the prestress plant.

4.3.4 IN-PLACE TESTING

To verify the accuracy of the maturity method for prestressed applications, two different types of in-place tests were conducted: the pullout test and compressive testing of cores. Testing was conducted in accordance with AASHTO and ASTM specifications.

4.3.4.1 Pullout Testing

Pullout tests were conducted on the top and the sides of the mock girder. The testing ages for the pullout tests were 12, 18, 24, 48 hours, and 7 and 28 days. All pullout tests were

conducted in accordance with ASTM C 900 (2001) and the recommendations supplied by the manufacturer of the pullout machine. Locations of all the tests are defined in Section 4.1.2.2. A load rate of 0.5 ± 0.2 kN/sec (112 ± 45 lbf/sec) was used for all pullout tests.

The top inserts were LOK-TEST inserts L-50 (floating inserts), which are designed for pullout loads between 0 and 100 kN, which allow a compressive strength range of 0 to 11,000 psi to be tested. ASTM C 900 requires that the spacing between inserts be no less than eight times the diameter of the disc of the insert. The floating inserts were thus spaced at 9 inches on center. Spacing from the center of the insert to the edge of the girder was $4\frac{1}{2}$ inches. This distance met the requirements of ASTM C 900 (2001), which states that the clear spacing of the insert to any formed edge of concrete should be more than four times the diameter of the disc. When installing the top inserts, the floating inserts were placed in the concrete four inches away from the final location and then pulled toward the final location. The floating inserts were then rotated to approximately a 10° angle from the top surface as recommended by the supplier of the inserts. This process was used to ensure that no air pockets would be trapped below the disk of the insert and good consolidation would be achieved. Figure 4-19 shows the floating inserts installed on the top of the girder.



Figure 4-19: Floating inserts

The side inserts were LOK-TEST inserts L-41, designed for pullout loads between 0 and 100 kN, which allow a compression strength range of 0 to 11,000 psi to be tested. These inserts had a cardboard backing so that the inserts could be nailed to wooden forms. The forms used for the mock girder were old forms that had rusted, so before proceeding with the project, the forms were cleaned with a wire-bristled grinder. Holes were drilled into the forms where the inserts were to be placed as shown in Figure 4-6. All ASTM C 900 (2001) spacing requirements were met and inserts were positioned so that the longitudinal steel and stirrups would not interfere with the pullout inserts' failure plane. The inserts were then installed by inserting a screw in the hole and attaching the cardboard and insert to the screw as shown in Figure 4-20. Figure 4-21 shows that the inserts and stirrup locations.



Figure 4-20: Side-mounted pullout inserts on mock girder forms



Figure 4-21: Mock girder form with pullout inserts and stirrups

Two access panels were cut in the sides of the forms so that pullout testing on the mock girder could be conducted at 12 hours (prior to form removal). Figure 4-22 shows the hole cut, the front and back of the panel, and the inserts installed on the panel. The access panels were then re-secured and caulked so that the concrete would not leak from the forms during construction. No extra steps were taken for consolidation around the side-mounted inserts.



Figure 4-22: Access panels in mock girder forms

4.3.4.2 Compressive Strength of Cores

Cores were extracted and tested to assess the in-place compressive strength of the concrete. All core tests were conducted in accordance with ASTM C 42 (2004) and AASHTO T 24 (2002). The testing ages that were used for the cores were 7 and 28 days. Since the two standards differ the method by which cores should be conditioned and stored after removal from the girder, both methods were utilized. ASTM C 42 (2004) requires that the cores be removed a minimum of five days before the desired testing age.

The cores for the 7-day testing age were thus removed at 24 hours and the 28-day cores were removed at 21 days. All cores were removed at the same time in an effort to eliminate any discrepancy that could occur with differences in curing temperature from removal to testing. A standard coring machine secured to the girder with a vacuum-sealed pad was used so that holes would not have to be drilled into the mock girder to secure the core machine. A thin layer of quick-setting paste was applied to the top of the mock girder to help create a better vacuum seal for the coring machine. This layer was then cut off when the cores were trimmed to the desired length.

Since prestressed concrete is a high-early-strength concrete, the strength at 24 hours was adequate enough to core. As the cores were removed, the cores were alternately placed in the two different curing methods (specified by ASTM C 24 (2004) and AASHTO T 24 (2002)), in an attempt to eliminate possible anomalies between different areas of the girder. The inside diameter of the core barrel was 4 inches. The final dimension of the cores after cutting was 4 x 8 inches.

ASTM C 42 (2004) requires that once the cores are removed, they remain outside until the coring water has evaporated from the core or until one hour after removal. After the cores were surface dry, they were placed in sealed double bags and remained in the bags until the cores were cut. The same day the cores were removed from the mock girder, they were transported to Auburn University and cut to a length of 8 inches. After the cores were cut, the cutting water was allowed to evaporate before the cores were placed back into the double bags. The day before the cores were strength tested, the cores were sulfur capped in accordance with AASHTO T 231 (2005). After capping was

completed, the cores were placed back into the bags and then compression tested in accordance with AASHTO T 22 (2005).

AASHTO T 24 (2002) required a different curing method than ASTM C 42 (2004). When these cores were removed, they were immediately placed into a lime-saturated bath, and only removed for cutting and sulfur capping. Cutting and sulfur capping was achieved in the same manner as for the ASTM cores, but after the sulfur capping was completed the AASHTO cores were placed into the 100%-humidity curing room. The cores were not placed back into limewater since the limewater could damage the sulfur caps. Compression testing of the AASHTO cores was done with the same procedure as the ASTM cores. For four inch diameter cores, the loading rate required by AASHTO T 22 (2005) is between 15,000 and 37,000 lbs per minute. A load rate of 26,000 lbs per minute was used for all tests.

4.3.5 DATA ANALYSIS METHODS

The first data analysis step was to download all the temperature data and strength data. The strength data was reviewed to eliminate any outliers. The accumulation of the maturity was determined for the molded specimens and for the girder at the location where the in-place testing was conducted. Strength-maturity relationships were then developed using the strength and maturity data. Afterwards, the accuracy of the maturity method was evaluated by assessing all of the errors obtained between the measured and predicted strengths. Finally, confidence levels were developed to evaluate the accuracy of the maturity method for the prestressed concrete application.

4.3.5.1 Data Assessment

ASTM and AASHTO standards were used to eliminate potential outliers in the strength data. The coefficient of variation of each type of testing was used to identify the outliers. If the range of compression test results (defined in Equation 2-11) for three concrete cylinders cast under field conditions was within 9.5% then all specimens were used (AASHTO T 22 2005). If the percent range exceeded 9.5%, then the furthest outlier was removed, and the remaining test results were used.

For the pullout test, the same elimination process is used by ASTM C 900 (2001). The acceptable ranges for the pullout inserts is 31% for 5 pullout inserts, 34% for 7 pullout inserts, and 36% for 10 pullout inserts. Therefore acceptable range of 31% for the top inserts and 34% for the side inserts were used. The acceptable range used for the pullout cubes was 34%. As for the cores, the accepted range for a single operator was 13% (AASHTO T 24 2002).

After all the temperature data were collected, some small adjustments were made to the first couple of iButton readings. Hour zero was the time at which water contacted cement; therefore, any readings that were taken between the time water contacted cement and when the iButton sensors were covered with concrete had to be adjusted. To make this adjustment, the value of the first temperature reading recorded after the sensor was covered with concrete was used for all prior temperatures from time zero until this point. At most, this was only 2 to 3 readings.

One other adjustment was made to the temperature reading for the cores. Since two separate iButtons were used to measure the temperatures of the cores at different stages (one from the girder, the other placed into the core after being removed), a small

transitional adjustment was made in the temperature readings to eliminate the effects any heat generated by the cement used to install the iButton in the cores.

4.3.5.2 Strength-Maturity Relationships (S-M Relationships)

The cylinder strength and maturity data collected at each testing age were used to develop the S-M relationship. As stated in Section 2.4, there are multiple ways to define the best fit for a S-M relationship. The exponential function (Equation 2-6) was used to define the estimated strengths for the S-M relationships in this study. The general consensus is that the exponential function is the more accurate function to use (Carino 1997; Freiesleben Hansen and Pederson 1984).

At each testing age, the strength was estimated by the maturity method, and then the error between the measured strength and estimated strength was found. Each error was then squared and all the errors were summed for the entire data set. Using the solver function in Microsoft Excel®, the sum of error squared was minimized in by varying S_u , β , and τ to find the best values to fit the data set. Once the values of S_u , β , and τ were determined, the exponential function could be used to calculate the estimated strength at any maturity value of the concrete.

4.3.5.3 Calculations of Errors

Once all maturities had been calculated and the S-M relationships had been established, the accuracy of the strength estimated with the maturity method could be evaluated. The accuracy for all tests was determined by evaluating the percent error, absolute average error, and average absolute percent error. The error between the strength obtained by

testing molded cylinders and that estimated by the S-M relationship was calculated. Additionally error parameters were calculated for the strength obtained from the in-place strength test versus that estimated by the maturity method.

To calculate the percent error, the measured strength was subtracted from the estimated strength, and this difference was divided by the measured strength, and the results multiplied by 100, as shown in Equation 4-1.

$$\% Error = \left(\frac{\hat{y} - y}{y} \right) \times 100 \quad \text{Equation 4-1}$$

where, \hat{y} = estimated strength (psi), and
 y = measured strength (psi).

The absolute average error is not a true statistical value but is used by Carino and Tank (1992) to help establish a single parameter that can be evaluated to quantify the accuracy of the strength estimated by the maturity method for an entire data set. Equation 4-2 defines the absolute average error:

$$AAE = \frac{\sum (|\hat{y} - y|)}{n} \quad \text{Equation 4-2}$$

where, AAE = Average absolute error (psi), and
 n = number of ages tested in a data set.

The absolute average percent error is also used to establish a single parameter that can be evaluated to quantify the accuracy of the strength estimated by the maturity method for an entire data set. Equation 4-3 defines the absolute average percent error:

$$AA\%E = \frac{\sum(|\%Error|)}{n} \quad \text{Equation 4-3}$$

where, $AA\%E$ = Average absolute percent error.

4.3.5.4 Confidence Levels

Confidence levels were applied to the S-M relationships. To calculate confidence levels the coefficient of variation for each type of test was used. As stated in Section 4.1.1.1, the confidence levels that were used for the prestressed girder project were 50%, 75%, and 90% with a defective level of 10%. To calculate the strength corresponding to a defect level of 10% with various confidence levels, refer to Equation 2-9. Table 2-4 summarizes the corresponding K-values for the different confidence levels at a defect level of 10%. Table 4-3 shows the coefficient of variation for test data obtained from cylinders, cores, and pullout inserts.

Table 4-3: Coefficient of variation of test methods

Test Method	Coefficient of Variation	Reference
Compression Testing of Molded Cylinders	2.9%	AASHTO T 22 (2005)
Compression Testing of Cores	4.7%	AASHTO T 24 (2002)
Pullout Test	8.0%	ASTM C 900 (2001)

4.3.5.5 Acceptance Criteria

To determine if the maturity method is an accurate method for evaluating the strength development of concrete, an acceptance criterion had to be established. ASTM C 39 (2003) states that the acceptable range for compression tests of three field-cured cylinders is 9.5%. Also ASTM C 1074 (2004) states that if the measured concrete strength of a

structure consistently exceeds the strength estimated with the maturity method by 10% or more, then a new S-M relationship is to be developed. Therefore, the criteria that if the strength estimated with the maturity method exceeds the measured strength of molded cylinders by more than 10%, the maturity method is not accurate. Since the coefficient of variation for the pullout test and core is higher than the compression tests of molded cylinders, if the strength estimated with the maturity method exceeded the measured strength by 15% or less the tests will be considered accurate.

4.4 PRESENTATION OF RESULTS

All test results for the prestressed girder project are presented in this section. Analysis and discussion of the test results will be presented in Section 4.5, along with the tables of errors and graphs that show the accuracy of the different test methods and the accuracy of the maturity method. The average cylinder, pullout, and core strengths data and corresponding maturity indices are presented in this section. Outliers have been removed from some test data and temperature data have been adjusted, as discussed in Section 4.3.5.1. Appendix B has all the individual strength and percent ranges for all testing that was conducted. Also located in Appendix B are pictures of the prestressed girder project, testing, and specimens.

4.4.1 BATCHED MATERIAL AND FRESH CONCRETE PROPERTIES

The total air content was 2.5%, which was acceptable for assessing the accuracy of the maturity method. Table 4-4 summarizes the fresh concrete properties of the concrete used in the mock girder.

Table 4-4: Fresh concrete properties for prestressed girder project concrete

Fresh Concrete Properties	Results
Air (%)	2.5%
Slump (in.)	7 ¼
Temperature (°F)	94

4.4.2 TEMPERATURE DATA

All of the concrete temperatures from the cylinders, pullout cubes, and cores, along with the ambient air temperatures, are shown in Figure 4-23. Two of the concrete temperature histories of the mock girder, including the maximum early-age temperature (Girder Location 4B) and minimum early-age temperature (Girder Location 1J), are also presented in Figure 4-23. The remainder of the temperature data are presented in Appendix B. Only the first four days were plotted because after that period, the temperatures of the specimens closely followed the ambient temperature cycle.

As shown in Figure 4-23, a substantial difference between the laboratory-cured specimens and the field-cured specimens existed for the first 24 hours. The field-cured specimens simulated the mock girder temperature more accurately than the laboratory-cured specimens. Even though the temperatures from the field-cured specimens did not reach the maximum temperature recorded in the girder, they did follow the minimum girder temperatures more closely.

The temperature history of the 7-day ASTM C 42 and AASHTO T 24 cured cores are presented in Figure 4-24, and the temperature history of the 28-day ASTM C 42 and AASHTO T 24 cured cores are shown in Figure 4-25.

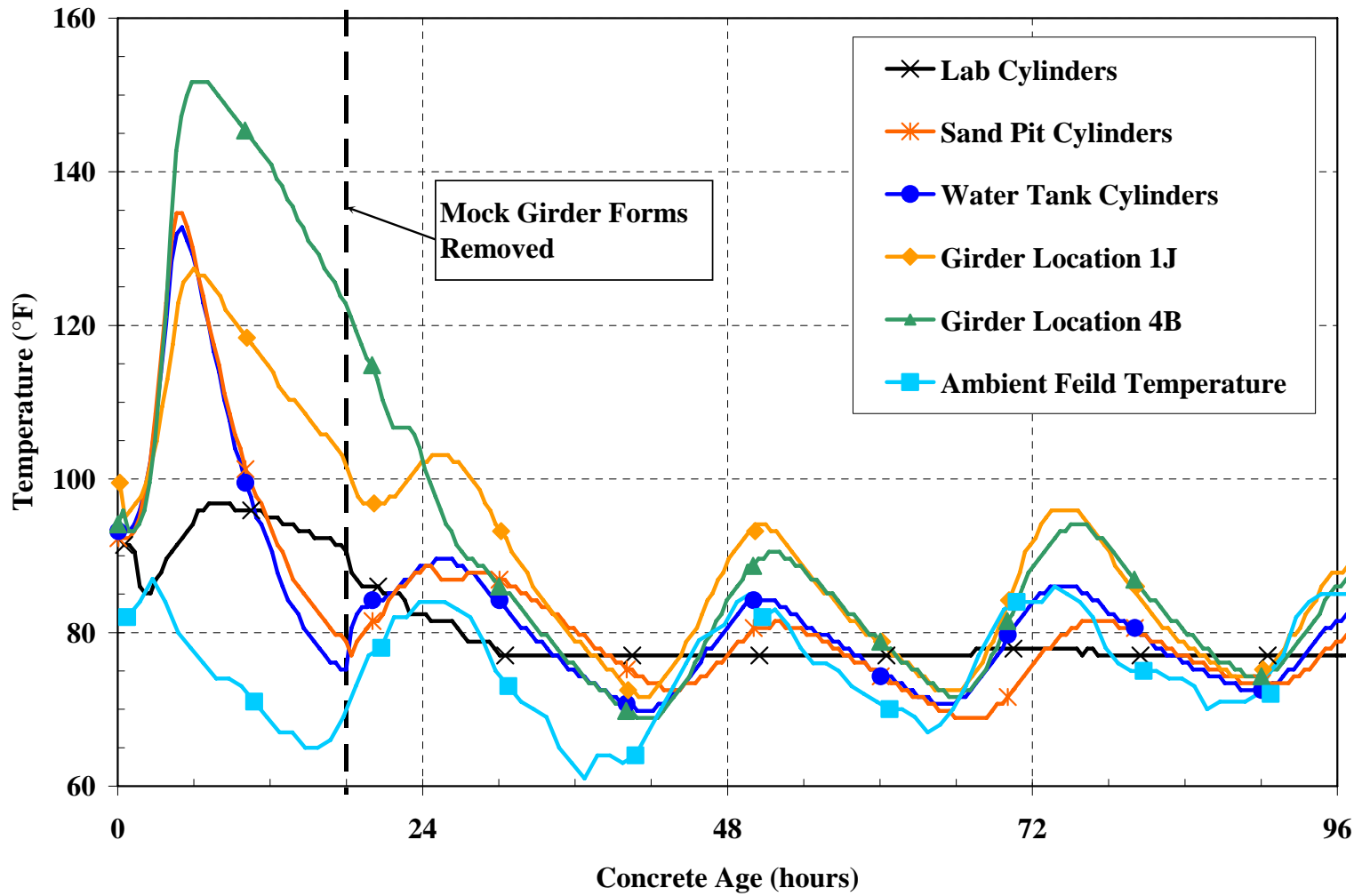

Figure 4-23: Temperature history of the molded specimens and the mock girder

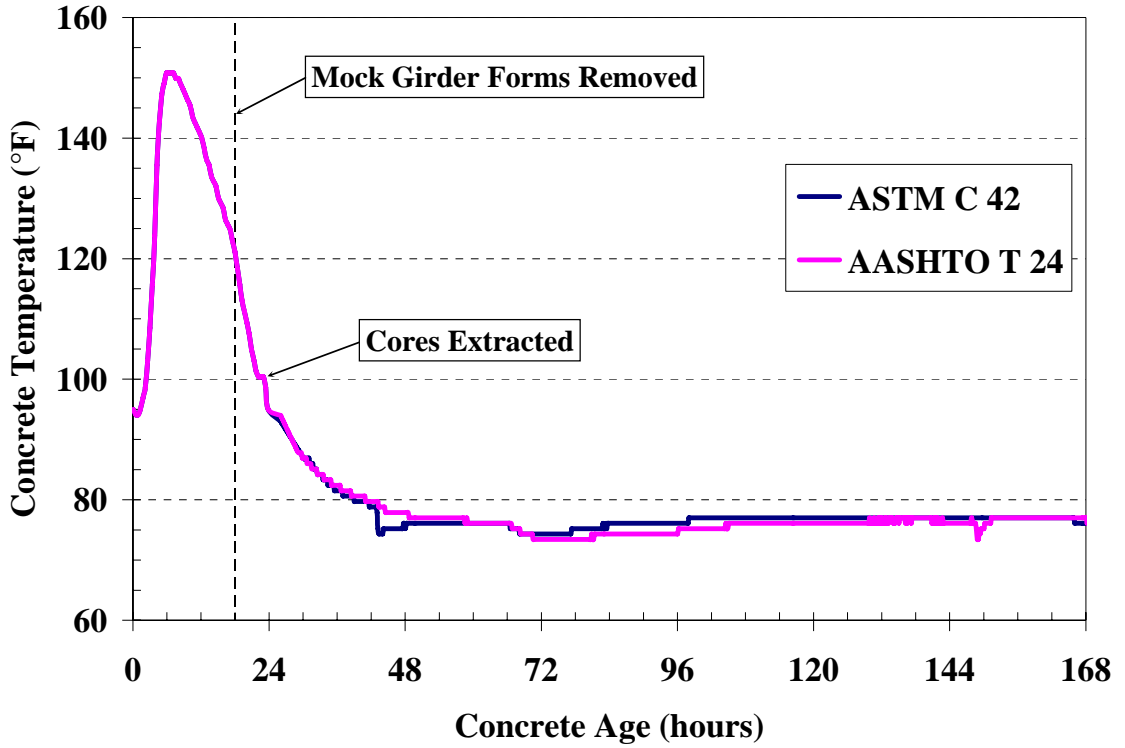

Figure 4-24: Temperature history of the 7-day cores

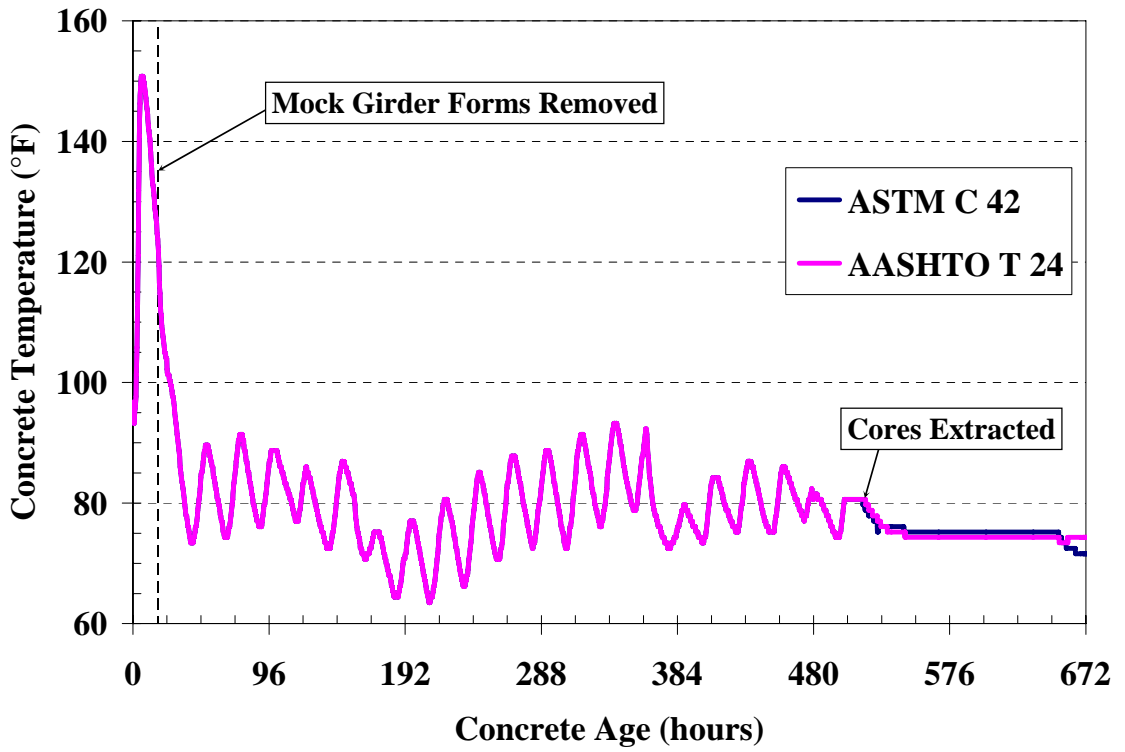

Figure 4-25: Temperature history of the 28-day cores

4.4.3 STRENGTH DATA

The maturity values and average strength test results for the laboratory-cured specimens are summarized in Table 4-5. No outliers were removed from the data set; however, one 8-hour cylinder result was discarded due to malfunction with the compression machine at the prestressing plant.

Table 4-5: *Laboratory cylinders strength and maturity data*

Target Age	Concrete Age (hours)	Nurse-Saul Maturity (°C • hours)		Arrhenius Maturity (hours)		Measured Strength (psi)
		T _o = -10 °C	T _o = 0 °C	E = 33.5 kJ/mol	E = 40 kJ/mol	
11 hr	11.9	515	397	19.2	21.2	3,250
20 hr	20.4	874	673	32.5	35.6	4,500
34 hr	33.7	1,367	1,033	48.6	52.4	5,000
42 hr	42.2	1,673	1,251	58.3	62.3	4,990
66 hr	66.1	2,504	1,845	84.6	89.1	5,330
4 day	95.3	3,530	2,579	117.1	122.3	5,720
7 day	168.2	6,042	4,362	195.9	202.3	6,080
28 day	671.9	22,769	16,052	709.7	718.2	7,000

A summary of the maturity and strength data for the lime-saturated water-tank and damp-sand-pit cylinders are presented in Table 4-6 and Table 4-7. All strength data were within the acceptable range for concrete cylinders, so no outliers were removed from the data sets. Again, two 8-hour cylinders were removed due to malfunction with the compression machine. For the test ages of 48 hours, 4 days, 7 days, and 28 days, only two specimens were cast for both the lime-saturated water-tank and the damp-sand-pit. Only two cylinders were made for each testing age because there was not enough concrete was produced to make all of the cylinders. ALDOT allows strength testing to be

conducted with only two cylinders. While this is not the best way to obtain accurate strength results, it is an acceptable method. In addition, concrete strength tended to have less variability at later ages, so two specimens were used for the later age tests. All individual strength test results for the cylinders are presented in Appendix B.

Table 4-6: *Lime-saturated water-tank* cylinders strength and maturity data

Target Age	Concrete Age (hours)	Nurse-Saul Maturity (°C • hours)		Arrhenius Maturity (hours)		Measured Strength (psi)
		T _o = -10 °C	T _o = 0 °C	E = 33.5 kJ/mol	E = 40 kJ/mol	
8 hr	8.1	445	365	22.3	27.5	3,600
12 hr	12.2	649	528	30.9	37.4	4,400
18 hr	18.4	879	699	38.7	45.7	4,690
24 hr	24.2	1,119	877	46.8	54.3	5,070
48 hr	48.5	2,010	1,526	76.2	84.8	5,330
4 day	96.0	3,649	2,690	127.8	137.3	6,170
7 day	168.0	6,181	4,502	208.3	219.6	6,110
28 day	671.3	23,818	17,105	770.8	795.5	7,050

Table 4-7: *Damp-sand-pit* cylinder strength and maturity data

Target Age	Concrete Age (hours)	Nurse-Saul Maturity (°C • hours)		Arrhenius Maturity (hours)		Measured Strength (psi)
		T _o = -10 °C	T _o = 0 °C	E = 33.5 kJ/mol	E = 40 kJ/mol	
8 hr	8.1	442	362	21.8	26.8	3,600
12 hr	12.2	642	520	30.1	36.2	4,400
18 hr	18.4	858	678	37.1	43.6	4,690
24 hr	24.4	1,103	861	45.5	52.5	4,980
48 hr	48.5	1,967	1,483	73.5	81.4	5,280
4 day	96.0	3,658	2,699	127.9	137.3	5,850
7 day	168.6	6,239	4,555	210.7	222.4	6,190
28 day	671.5	24,445	17,732	802.9	834.8	7,240

The strength development of all molded cylinder types are presented in Figure 4-26. Only the first 7 days are shown to illustrate the difference between the strength development of the field-cured and laboratory-cured molded cylinders. The exponential function was used to characterize the strength gain of the concrete. The characteristic values, S_u , β , and τ , along with the R_2 value for the strength development relationships are documented in Appendix B.

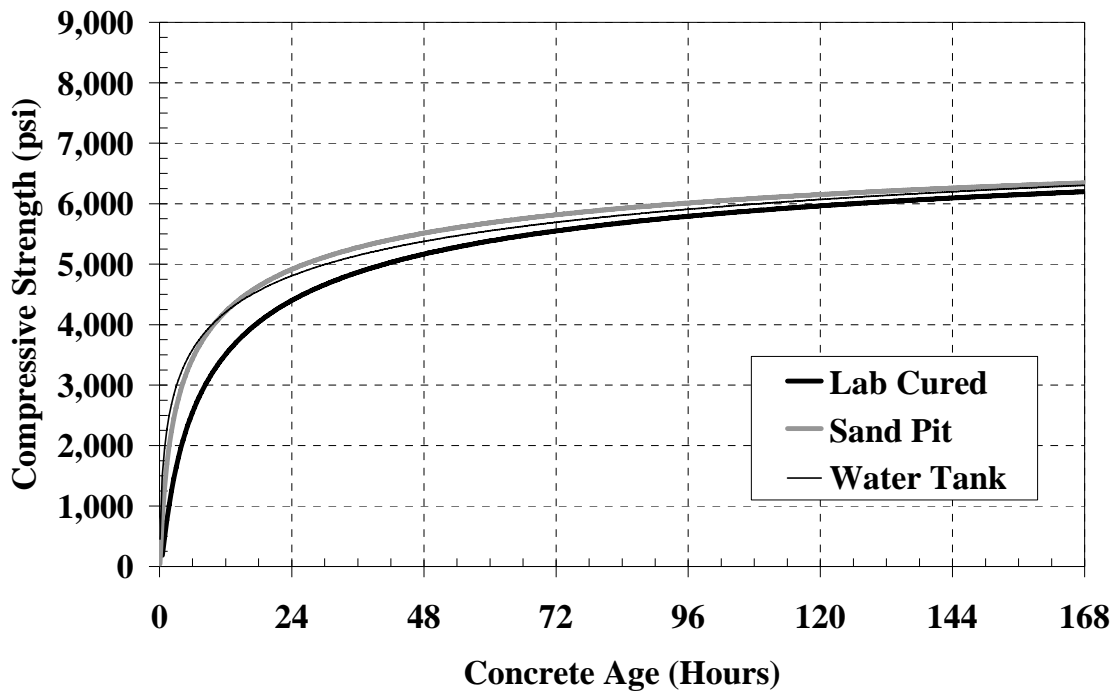

Figure 4-26: Concrete strength versus concrete age

The average in-place strength and maturity data for the top pullouts are presented in Table 4-8. The average in-place strength and maturity data for the side pullouts are presented in Table 4-9. All outliers were removed from the data sets. Some of side inserts were damaged during the construction process and were unable to be tested, while some of the top inserts could not be tested because of problems that occurred with placing the

floating inserts in the fresh concrete. These data were not included in the overall test results. Results for all individual pullout tests are summarized in Appendix B.

Table 4-8: In-place *top pullout* strength and maturity data

Target Age	Concrete Age (hours)	Nurse-Saul Maturity (°C • hours)		Arrhenius Maturity (hours)		Pullout Compressive Strength (psi)
		T _o = -10 °C	T _o = 0 °C	E = 33.5 kJ/mol	E = 40 kJ/mol	
12 hr	12.2	789	668	50.0	67.0	4,540
18 hr	18.4	1185	1002	67.2	95.5	4,960
24 hr	24.1	1469	1231	85.0	110.5	5,500
48 hr	49.2	2471	1979	119.9	147.6	5,790
7 day	167.2	6963	5294	272.0	308.0	6,730
28 day	671.2	25757	18769	900.0	966.5	8,270

Table 4-9: In-place *side pullout* strength and maturity data

Target Age	Concrete Age (hours)	Nurse-Saul Maturity (°C • hours)		Arrhenius Maturity (hours)		Pullout Compressive Strength (psi)
		T _o = -10 °C	T _o = 0 °C	E = 33.5 kJ/mol	E = 40 kJ/mol	
12 hr	12.2	767	646	46.0	60.4	4,010
18 hr	18.4	1153	969	72.3	87.3	4,940
24 hr	24.1	1481	1243	85.8	111.3	5,270
48 hr	49.2	2537	2046	124.5	153.8	5,650
7 day	167.2	7025	5357	278.4	317.6	6,140
28 day	671.2	25479	19046	883.9	946.7	6,680

Average core strength and maturity data are summarized in Tables 4-10 and 4-11. Again all outliers were removed from the data set before the data were averaged. Also, one core each from the ASTM C 42 - 7 day, AASHTO T 24 - 7 day, and AASHTO T 24 - 28 day tests could not be extracted from the girder as the vacuum pad could not be

properly secured to the top of the girder. In Appendix B the individual strength test results, the dimensions of cores, and the layout of the core removal are reported.

Table 4-10: In-place ASTM C 42 core strength and maturity data

Target Age	Concrete Age (hours)	Nurse-Saul Maturity (°C • hours)		Arrhenius Maturity (hours)		Core Compressive Strength (psi)
		T _o = -10 °C	T _o = 0 °C	E = 33.5 kJ/mol	E = 40 kJ/mol	
7 day	168.5	6,574	4,890	248.8	279.0	5,280
28 day	672.6	25,015	18,198	848.1	898.6	6,090

Table 4-11: In-place AASHTO T 24 core strength and maturity data

Target Age	Concrete Age (hours)	Nurse-Saul Maturity (°C • hours)		Arrhenius Maturity (hours)		Core Compressive Strength (psi)
		T _o = -10 °C	T _o = 0 °C	E = 33.5 kJ/mol	E = 40 kJ/mol	
7 day	168.7	6,550	4,864	247.6	277.5	5,030
28 day	672.2	24,987	18,172	846.9	897.1	5,910

The set of average strength and maturity data for the pullout cubes is presented in Table 4-12. One insert was not tested at 18 hours due to the insert being improperly installed in the pullout cube. Two outliers were removed from the data set, one at 48 hours and the other at 7 days. The individual test results for the pullout cubes are presented in Appendix B.

Table 4-12: Pullout cube strength and maturity data

Target Age	Concrete Age (hours)	Nurse-Saul Maturity (°C • hours)		Arrhenius Maturity (hours)		Pullout Cube Compressive Strength (psi)
		T _o = -10 °C	T _o = 0 °C	E = 33.5 kJ/mol	E = 40 kJ/mol	
18 hr	19.0	1,052	864	53.1	65.9	5,330
48 hr	49.7	2,184	1,687	90.4	104.7	5,740
7 day	167.7	6,376	4,700	224.9	242.8	7,040

4.4.4 STRENGTH-MATURITY RELATIONSHIP (S-M RELATIONSHIP)

S-M relationships were developed as stated in Section 4.3.5.3. The exponential function was used to characterize the S-M relationship of the concrete. The best-fit S_u , β , and τ and R^2 values are summarized in Appendix B. Four different S-M relationships were developed using the Nurse-Saul maturity function with $T_o = -10\text{ }^\circ\text{C}$ and $0\text{ }^\circ\text{C}$ and the Arrhenius maturity function with $E = 33,500\text{ J/mol}$ and $40,000\text{ J/mol}$. The strength and maturity data along with corresponding S-M relationships for all molded cylinders using the Nurse-Saul maturity function with $T_o = -10\text{ }^\circ\text{C}$ and $0\text{ }^\circ\text{C}$ are shown in Figures 4-27 and 4-28, respectively. The strength and maturity data along with corresponding S-M relationships for all molded cylinders using the Arrhenius maturity function with $E = 33,500\text{ J/mol}$ and $40,000\text{ J/mol}$ are shown in Figures 4-29 and 4-30, respectively.

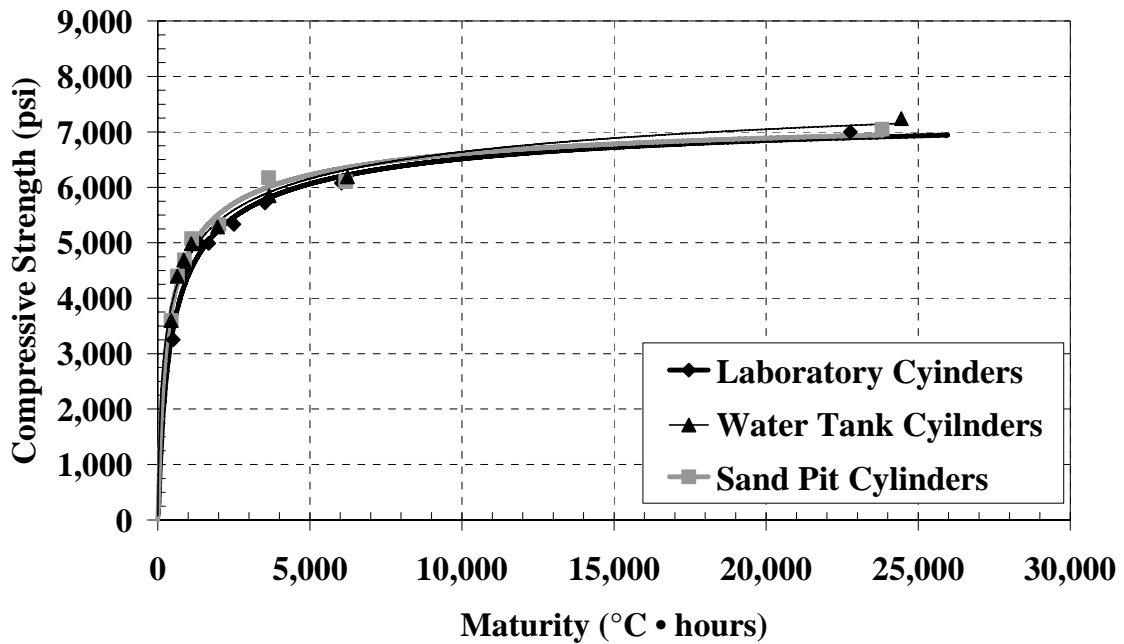

Figure 4-27: S-M relationships using the Nurse-Saul maturity function with $T_o = -10\text{ }^\circ\text{C}$

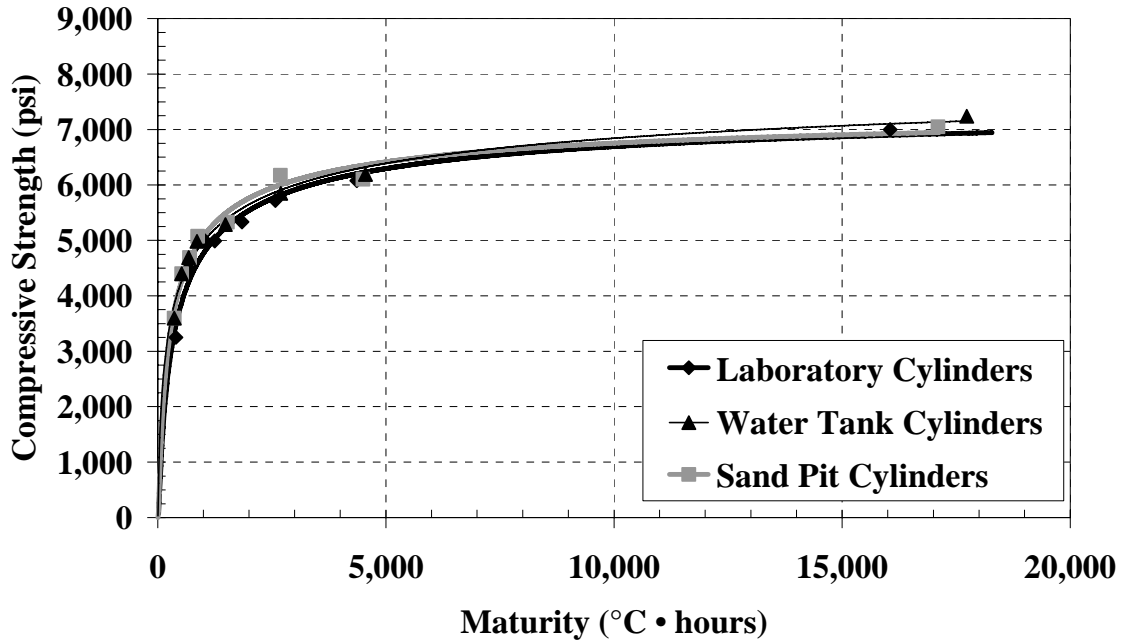

Figure 4-28: S-M relationships using the Nurse-Saul maturity function with $T_0 = 0\text{ }^\circ\text{C}$

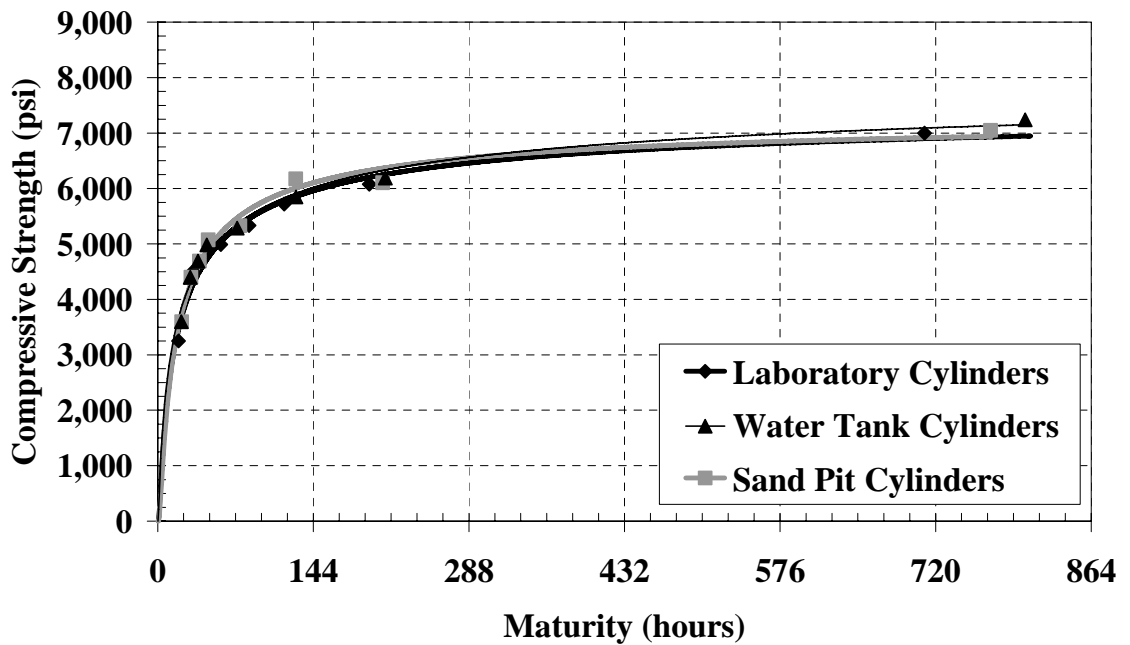

Figure 4-29: S-M relationships using the Arrhenius maturity function with $E = 33.5\text{ kJ/mol}$

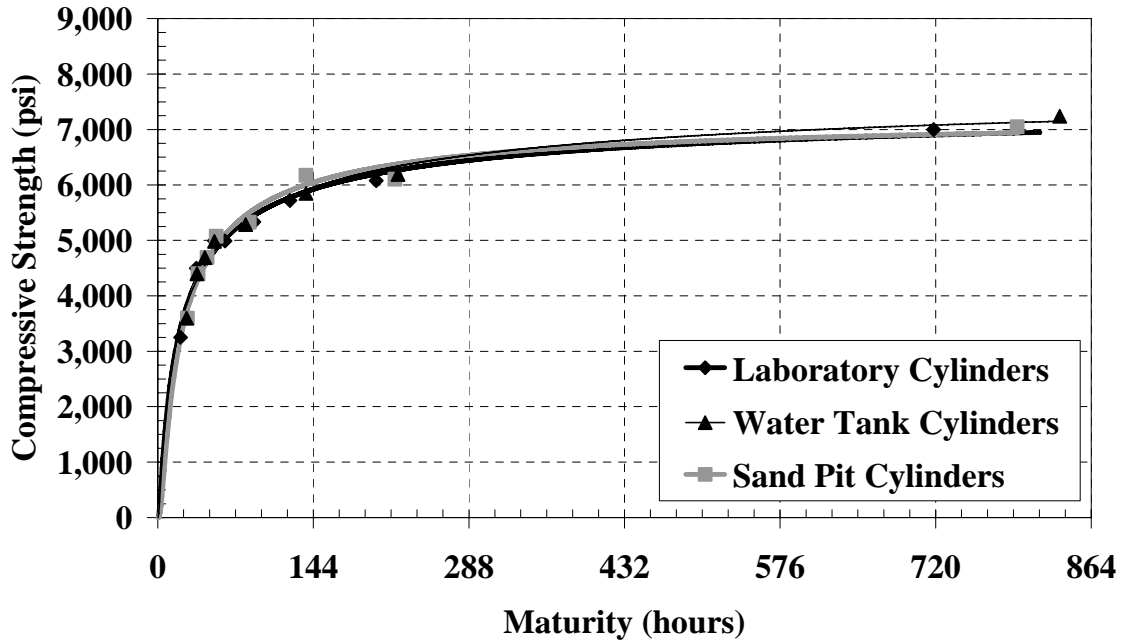

Figure 4-30: S-M relationships using the Arrhenius maturity function with $E = 40$ kJ/mol

In accordance with ASTM C 1074 (2004), the S-M relationship should be developed using cylinders that were cured under laboratory conditions in accordance with ASTM C 192 (2002). Therefore, the laboratory-cured cylinder S-M relationship was graphed with the strength and maturity data for the lime-saturated water-tank and damp-sand-pit cured cylinders. S-M relationships modified to reflect confidence levels of 50%, 75%, and 90% with a 10% defective level were determined and are shown in Figures 4-31 to 4-34. The strength development at various confidence levels were calculated as explained in Section 4.3.5.5. For the remainder of the chapter the S-M relationships that were developed from the laboratory-cured cylinders will be referred to as the “laboratory” S-M relationship. The S-M relationships that were developed from the field-cured lime-saturated water-tank cylinders will be referred to as the “water-tank”

S-M relationship and the S-M relationship that were developed from damp-sand-pit cylinders will be referred to as the “sand-pit” S-M relationship.

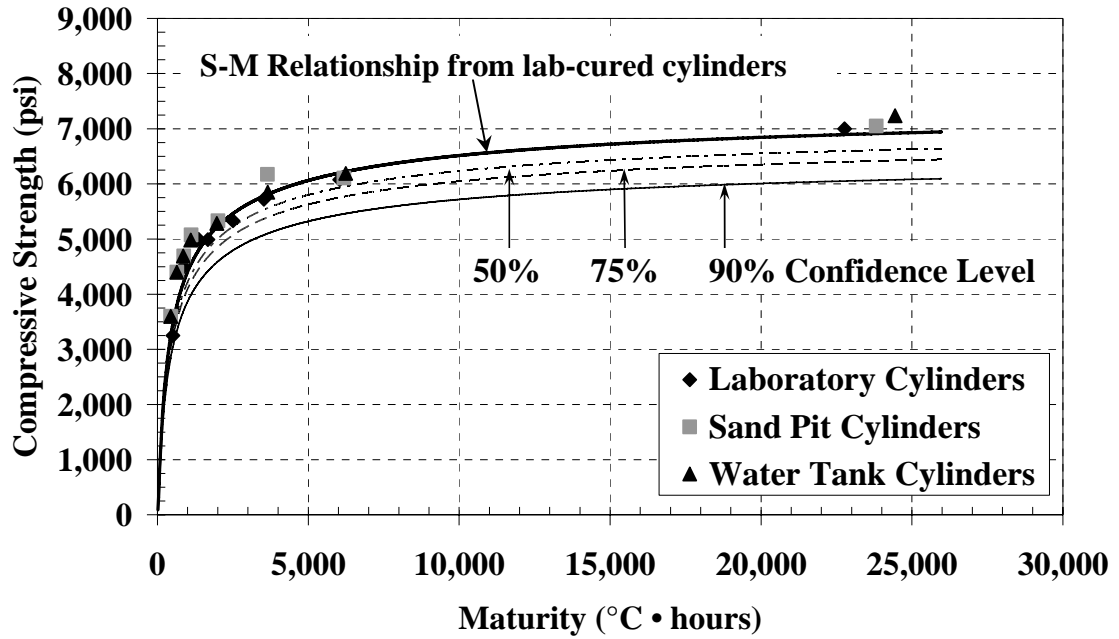

Figure 4-31: Laboratory S-M relationship with confidence levels ($T_0 = -10\text{ }^\circ\text{C}$)

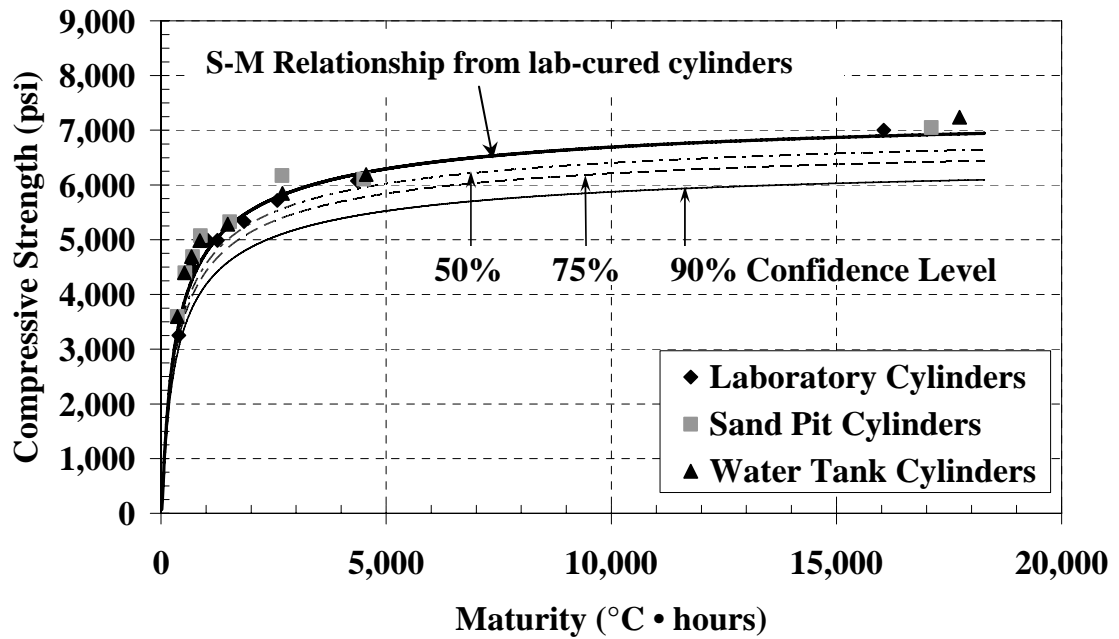

Figure 4-32: Laboratory S-M relationship with confidence levels ($T_0 = 0\text{ }^\circ\text{C}$)

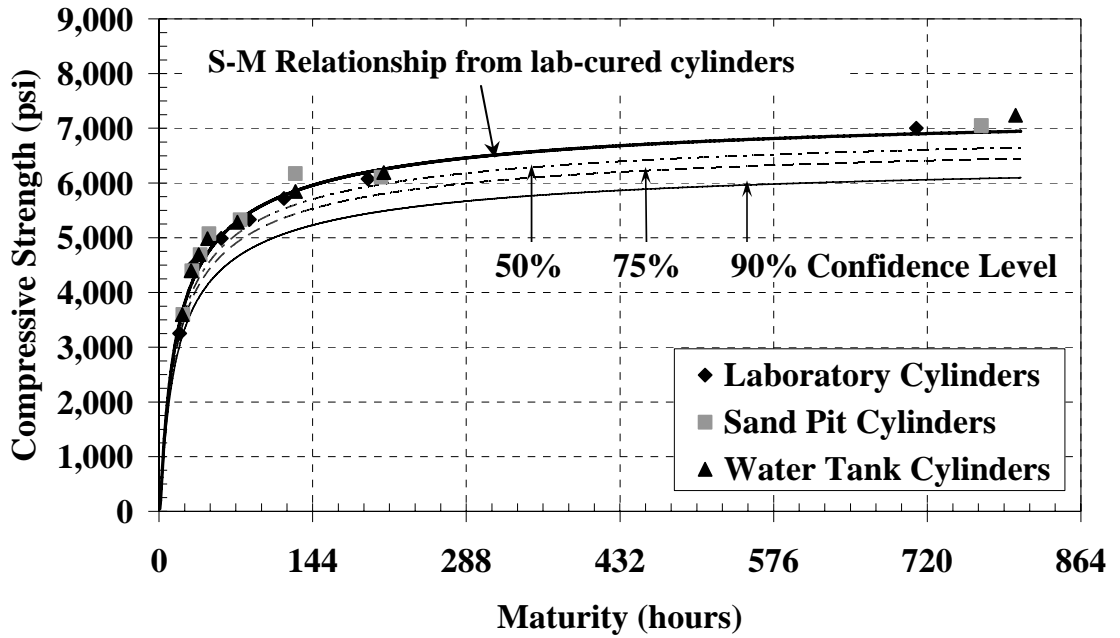

Figure 4-33: Laboratory S-M relationship with confidence levels (E = 33.5 kJ/mol)

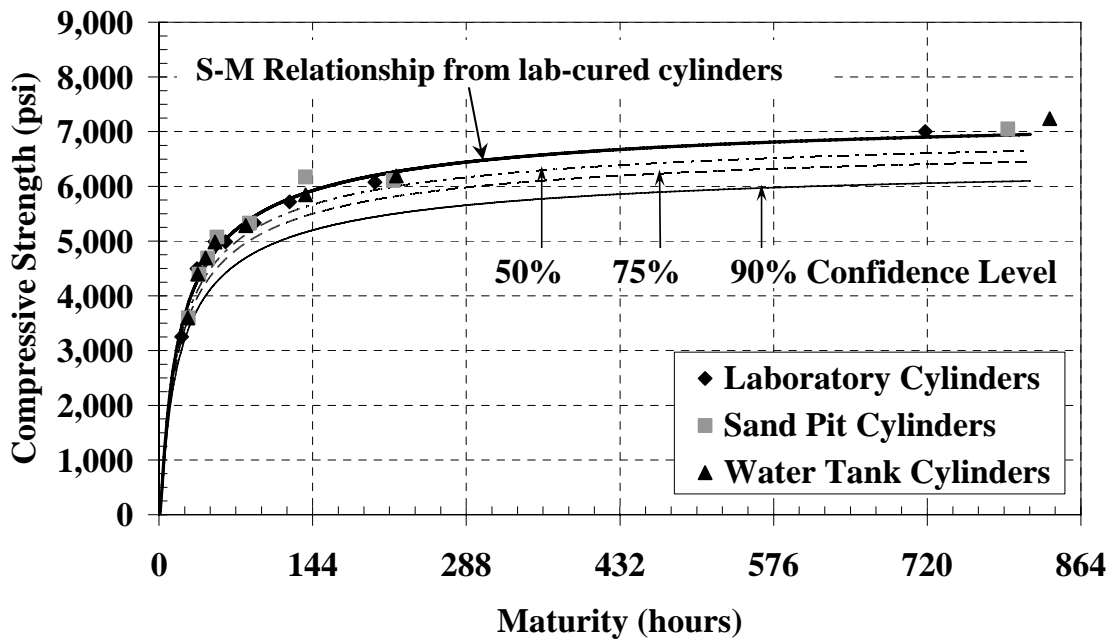

Figure 4-34: Laboratory S-M relationship with confidence levels (E = 40 kJ/mol)

S-M relationships developed from the field-cured cylinder were evaluated to determine if they would better represent the concrete strengths than the *laboratory* S-M relationship. S-M relationships were developed from both of the field-curing conditions. For the remainder of this chapter when discussing both S-M relationships developed from the field-curing conditions, the term “*field-cured*” S-M relationship will be used. The *field-cured* S-M relationships are presented in Appendix B.

4.4.5 IN-PLACE STRENGTH GRAPHS

To evaluate the in-place strength of the mock girder, pullout tests and compressive testing of cores were conducted. The strengths and maturities of the tests were graphed against all three S-M relationships, developed using results from the three different curing conditions of concrete cylinders. All four maturities were evaluated: Nurse-Saul maturity function with $T_0 = -10\text{ }^\circ\text{C}$ and $0\text{ }^\circ\text{C}$ and Arrhenius maturity function with $E = 33.5\text{ kJ/mol}$ and 40 kJ/mol . Along with the S-M relationship, strength for confidence levels of 50%, 75%, and 90% with 10% defect levels were also added to the graphs. The confidence levels for the pullouts and cores are different due to the number of specimens and coefficient of variation associated with the tests. The *laboratory* S-M relationships plotted with the average compressive strengths from the pullout tests are presented in Figures 4-35 to 4-38. The *field-cured* S-M relationships plotted with the average pullout compressive strengths are presented in Appendix B. The *laboratory* S-M relationships with plotted the average compressive strengths of the cores are presented in Figures 4-39 to 4-42. The *field-cured* S-M relationships plotted with the cores compressive strength

are presented in Appendix B. The average at each testing age was plotted, with bar lines showing the minimum and maximum compression strength for that testing age.

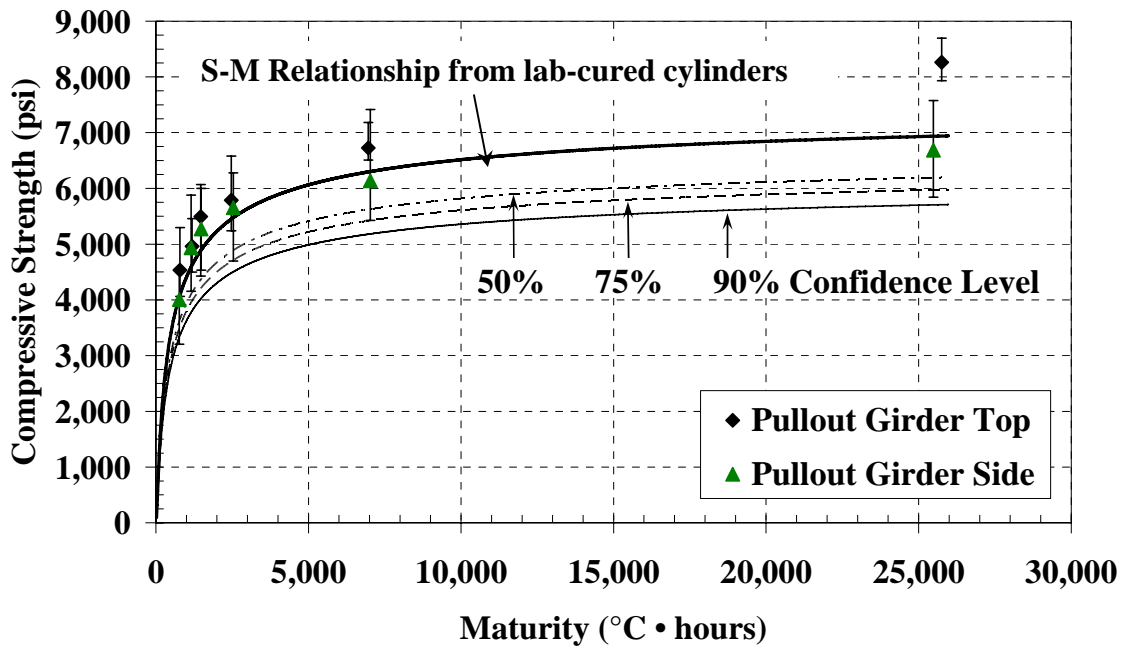

Figure 4-35: Pullout test with *laboratory* S-M relationship and confidence levels ($T_0 = -10\text{ }^\circ\text{C}$)

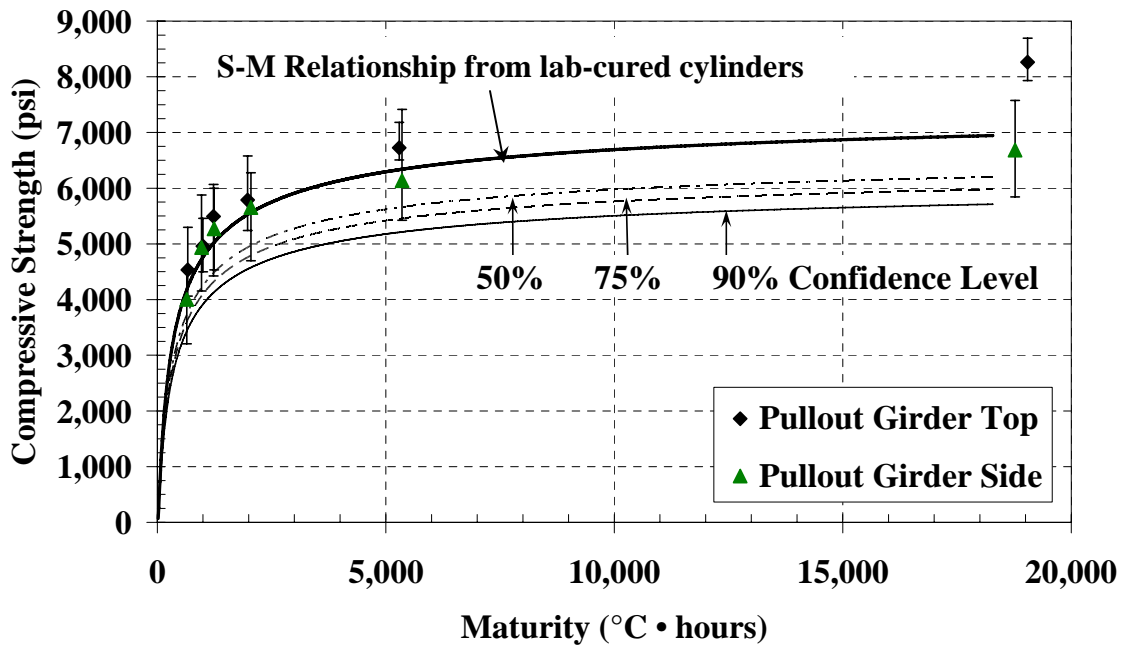

Figure 4-36: Pullout test with *laboratory* S-M relationship and confidence levels ($T_0 = 0\text{ }^\circ\text{C}$)

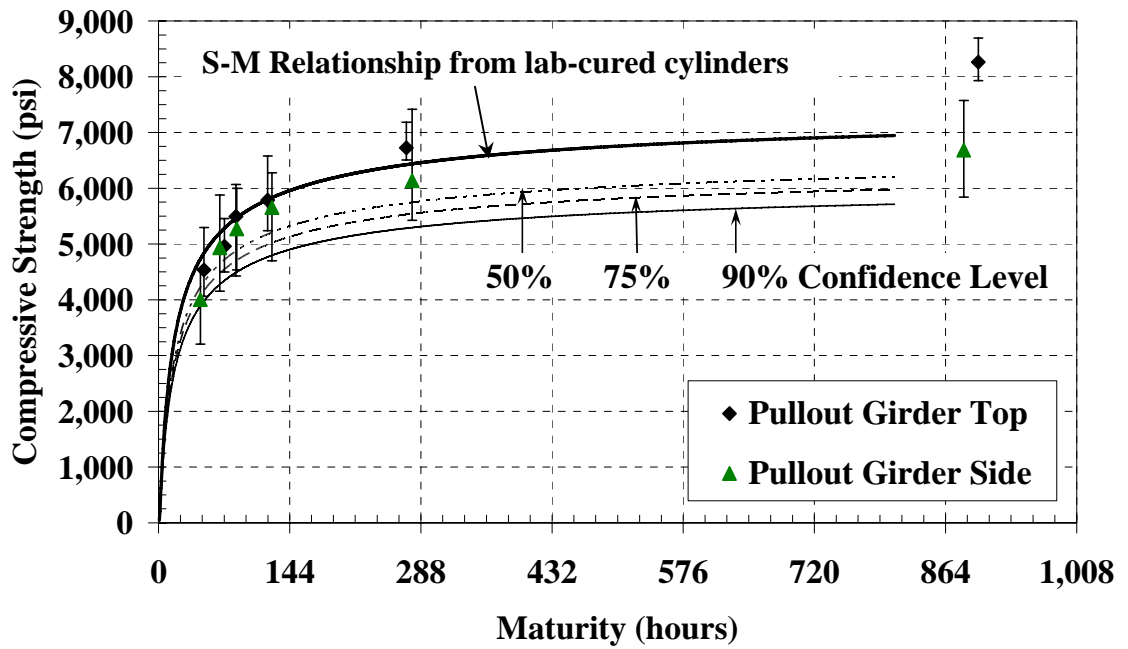

Figure 4-37: Pullout test with *laboratory* S-M relationship and confidence levels (E = 33.5 kJ/mol)

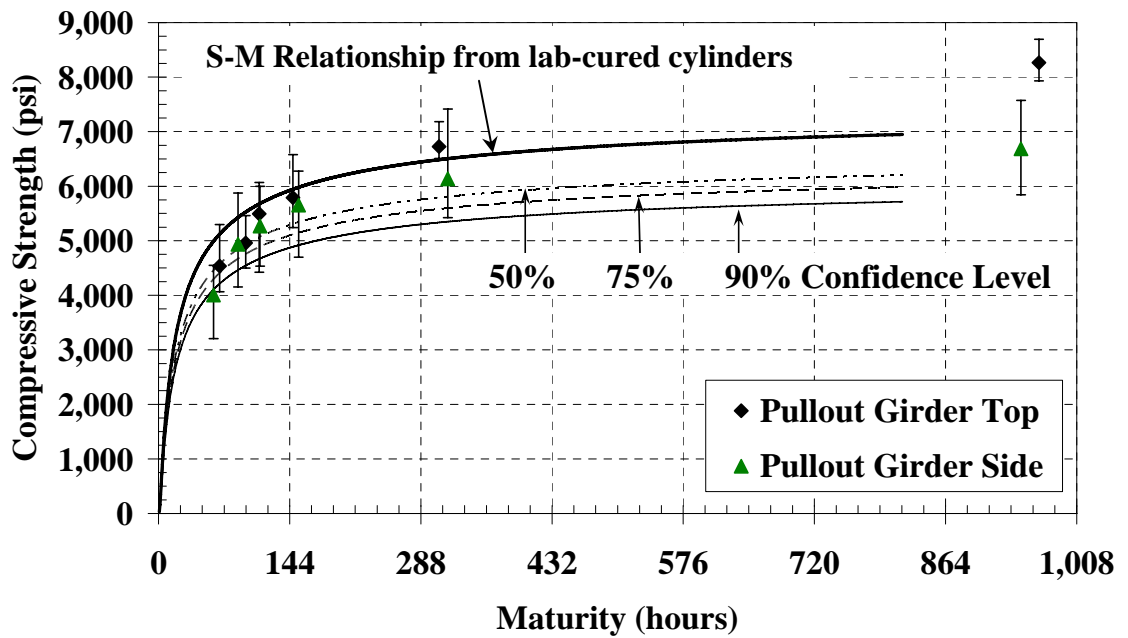

Figure 4-38: Pullout test with *laboratory* S-M relationship and confidence levels
($E = 40 \text{ kJ/mol}$)

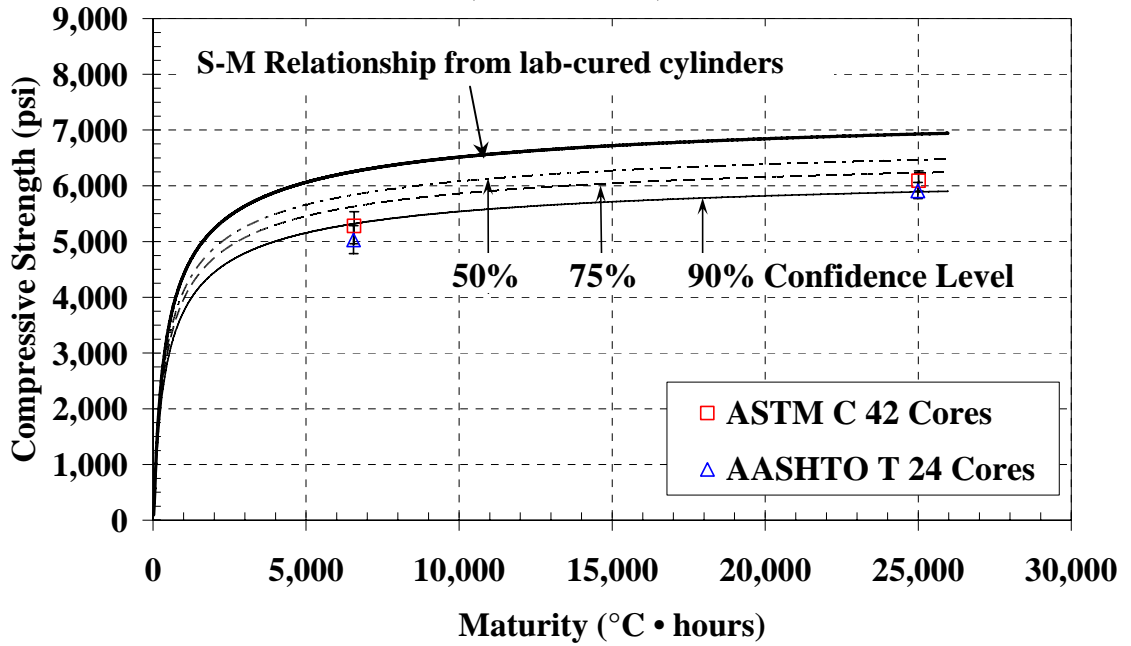

Figure 4-39: Cores with *laboratory* S-M relationship and confidence levels ($T_o = -10 \text{ }^{\circ}\text{C}$)

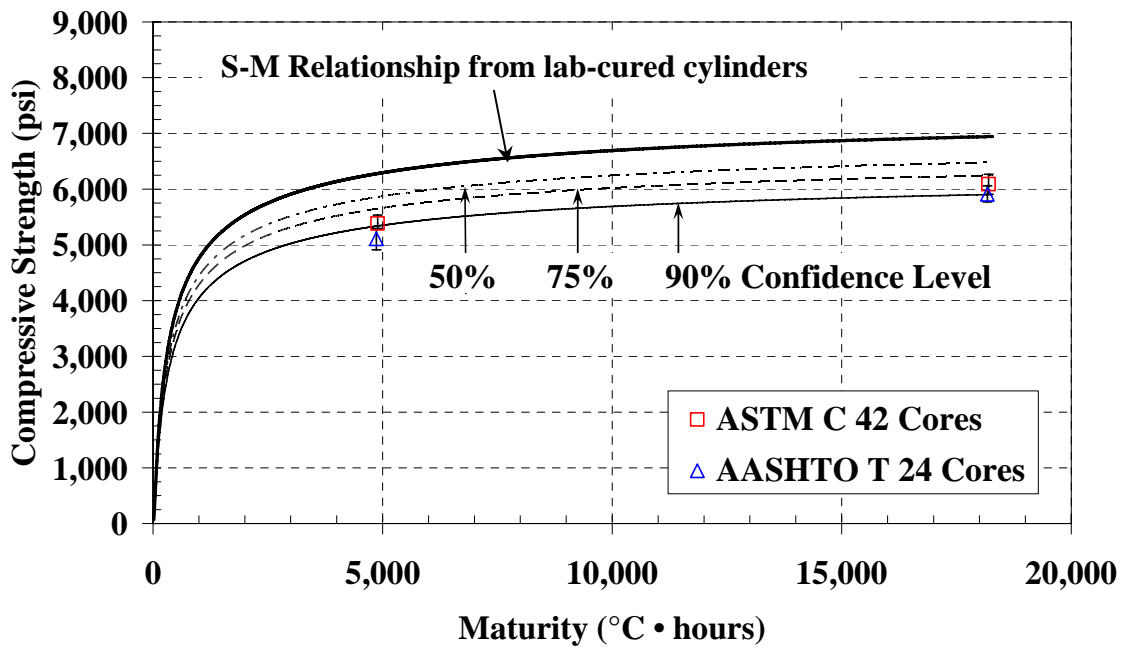

Figure 4-40: Cores with *laboratory* S-M relationship and confidence levels ($T_o = 0 \text{ }^{\circ}\text{C}$)

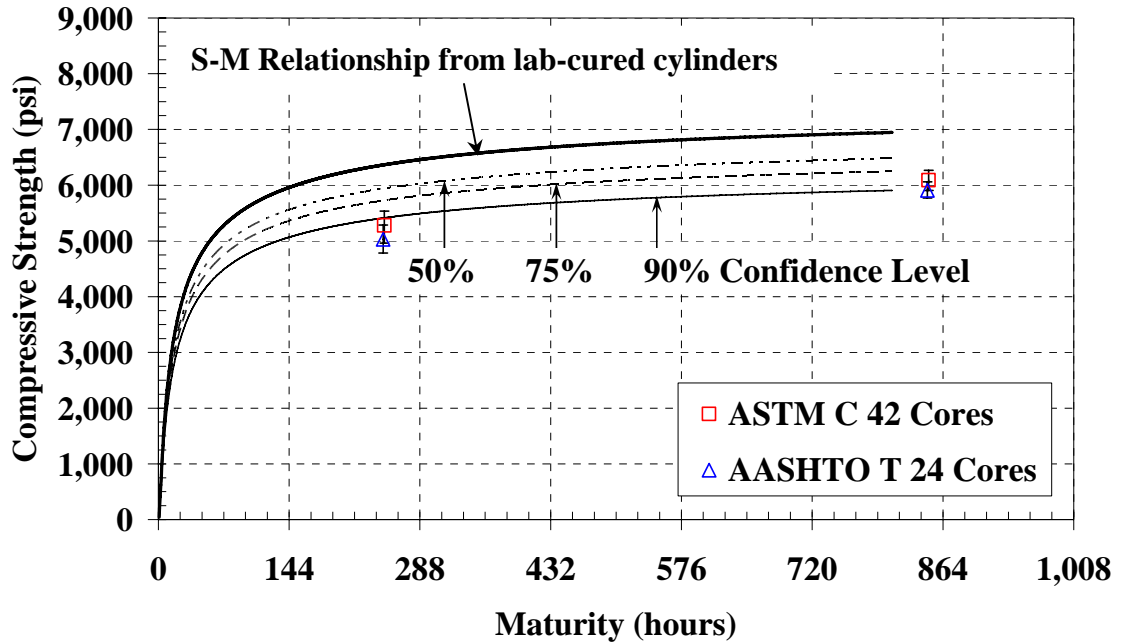

Figure 4-41: Cores with *laboratory* S-M relationship and confidence levels (E = 33.5 kJ/mol)

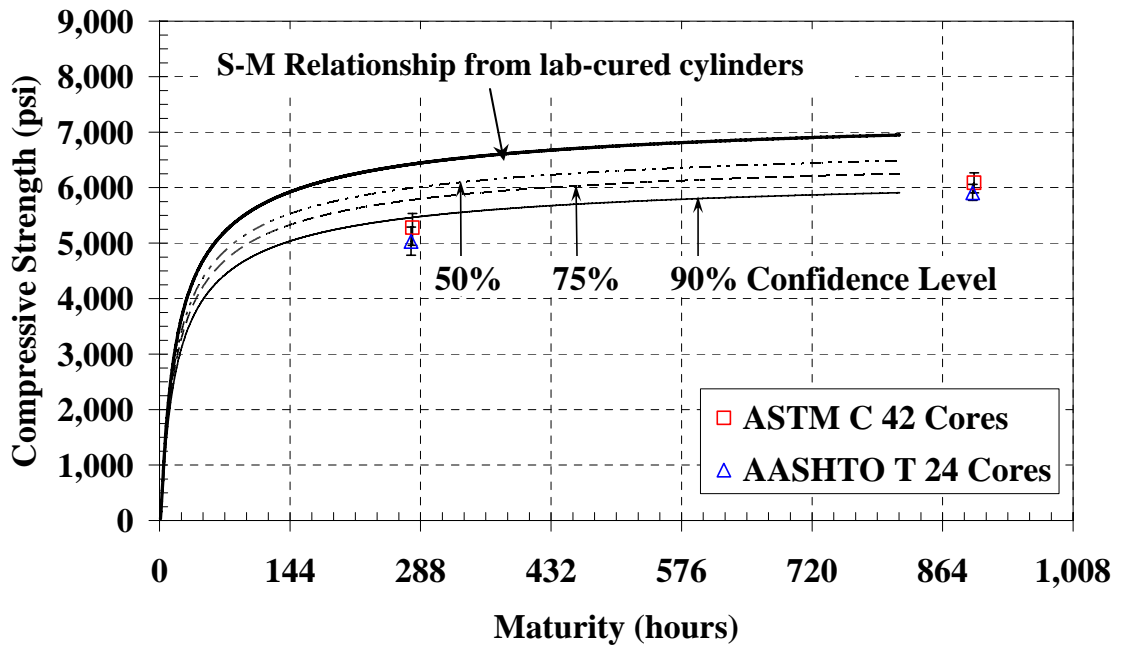

Figure 4-42: Cores with *laboratory* S-M relationship and confidence levels (E = 40 kJ/mol)

4.5 ANALYSIS OF RESULTS

Parameters that were stated in Section 4.3.5 will be used to determine whether the maturity method is an accurate and appropriate method to estimate the strength development for prestressed concrete applications.

4.5.1 ACCURACY OF VARIOUS MATURITY METHODS

Before the accuracy of the maturity method could be assessed, the *laboratory S-M* relationship was checked to evaluate the fit of the S-M relationship to the strength and maturity data of the laboratory-cured cylinders. The percent errors at each testing age and average absolute error for the entire set were calculated using the strengths from *laboratory S-M* relationship that corresponded to the measured strengths of the laboratory-cured specimens at the same maturity. Results of this process are presented in Table 4-13. The percent errors were calculated using Equation 4-1 and the average absolute errors were calculated using Equation 4-2. The strengths from the *laboratory S-M* relationship that correspond to the laboratory-cured cylinders strengths are presented in Appendix B. If the percent error is negative, then the maturity method underestimates the strength, which is considered to be conservative. If the error is positive, then the maturity method overestimates the strength. As long as the maturity method did not overestimate the strength by more than 10%, then the maturity method were considered accurate for estimating the strength of the molded cylinders.

Table 4-13: Evaluation of the errors of the *laboratory* S-M relationship for the laboratory-cured cylinders

	Concrete Age (hours)	Nurse-Saul Function		Arrhenius Function	
		T _o = -10 °C	T _o = 0 °C	E = 40 kJ/mol	E = 33.5 kJ/mol
<i>Percent Errors</i>	11.9	7%	6%	6%	6%
	20.4	-6%	-6%	-5%	-6%
	33.7	-4%	-4%	-4%	-4%
	42.2	1%	1%	1%	1%
	66.1	2%	2%	2%	2%
	95.3	1%	1%	1%	1%
	168.2	2%	2%	2%	2%
	671.9	-2%	-1%	-1%	-1%
<i>Average Absolute Error (psi)</i>		192	187	175	182

- Negative percent error reflects an underestimation of the measured strength
+ Positive percent error reflects an overestimation of the measured strength

When examining the average absolute error for the set of laboratory cylinders, the average absolute error ranged from 175 to 192 psi for all four maturity methods. The largest percent error was 7%. Since the average absolute errors were below 200 psi and the percent errors were less than 10%, the laboratory S-M relationships were considered to fit the laboratory-cured cylinder data very well.

ASTM C 1074 (2004) recommends that the S-M relationship be created with cylinders cured in laboratory conditions. The average absolute errors and percent errors at each testing age were calculated to compare the estimated strength from the laboratory-cured specimens to the measured strength of the field-cured cylinders. The percent error and average absolute errors are presented in Table 4-14. The estimated strengths from the *laboratory* S-M relationship for both sets of field-cured cylinders are presented in

Appendix B. The estimated strength from the *laboratory* S-M relationship versus the corresponding measured strengths for the field-cured cylinders are presented in Figures 4-43 to 4-46. A 45°-line was plotted on the graphs to illustrate the condition for which the estimated strengths and measured strengths are equal. In addition, $\pm 10\%$ and $\pm 20\%$ error lines are added to the plots to show the magnitude of the error.

Table 4-14: Percent errors and average absolute errors for field-cured cylinder data using *laboratory* S-M relationships

		Concrete Age (hours)	Nurse-Saul Function		Arrhenius Function	
			T _o = -10 °C	T _o = 0 °C	E = 40 kJ/mol	E = 33.5 kJ/mol
Sand Pit Cylinder	Percent Errors	8.1	-10%	-7%	7%	2%
		12.2	-13%	-12%	-1%	-5%
		18.4	-10%	-9%	-1%	-4%
		24.2	-10%	-9%	-4%	-6%
		48.5	-2%	-1%	1%	0%
		96.0	-6%	-6%	-5%	-5%
		168.0	2%	2%	3%	2%
		671.3	-2%	-2%	-2%	-2%
		Average Absolute Error (psi)	437	387	208	230
Water Tank Cylinder	Percent Errors	8.1	-10%	-8%	6%	1%
		12.2	-14%	-12%	-3%	-6%
		18.4	-10%	-9%	-3%	-5%
		24.4	-9%	-8%	-3%	-5%
		48.5	-1%	-1%	1%	0%
		96.0	-1%	0%	1%	0%
		168.6	1%	1%	1%	1%
		671.5	-4%	-4%	-4%	-4%
		Average Absolute Error (psi)	395	348	182	202

- Negative percent error reflects an underestimation of the measured strength

+ Positive percent error reflects an overestimation of the measured strength

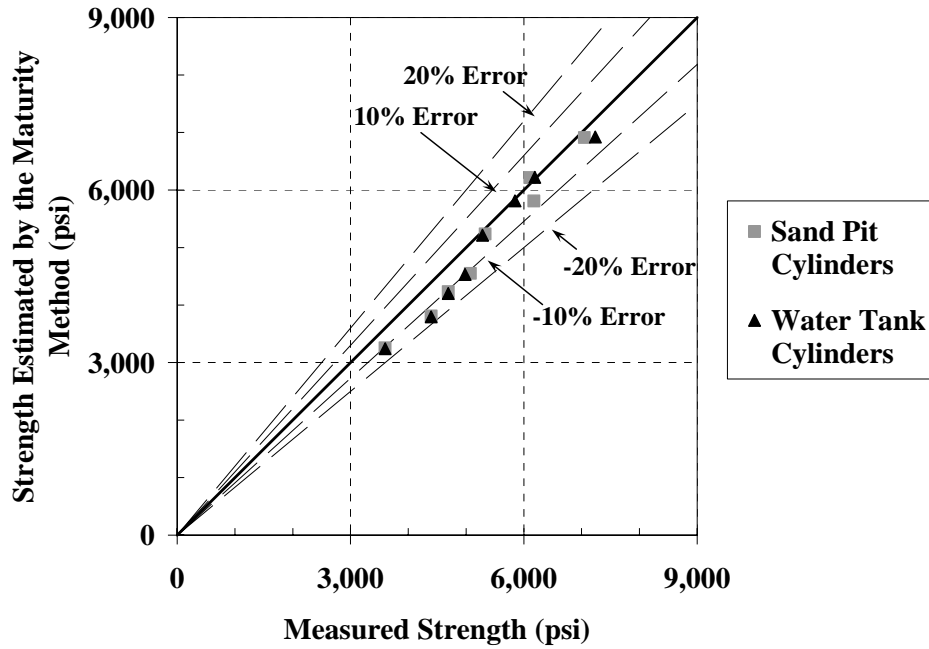

Figure 4-43: 45°-line graph for estimated cylinder strengths from the *laboratory* S-M relationship using the Nurse-Saul maturity function ($T_o = -10\text{ }^\circ\text{C}$)

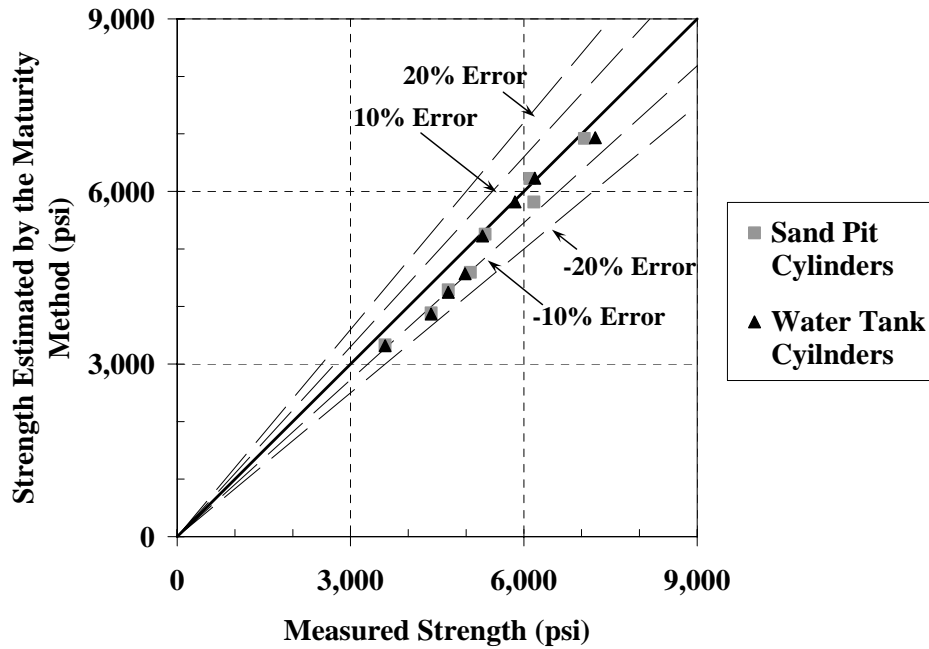

Figure 4-44: 45°-line graph for estimated cylinder strengths from the *laboratory* S-M relationship using the Nurse-Saul maturity function ($T_o = 0\text{ }^\circ\text{C}$)

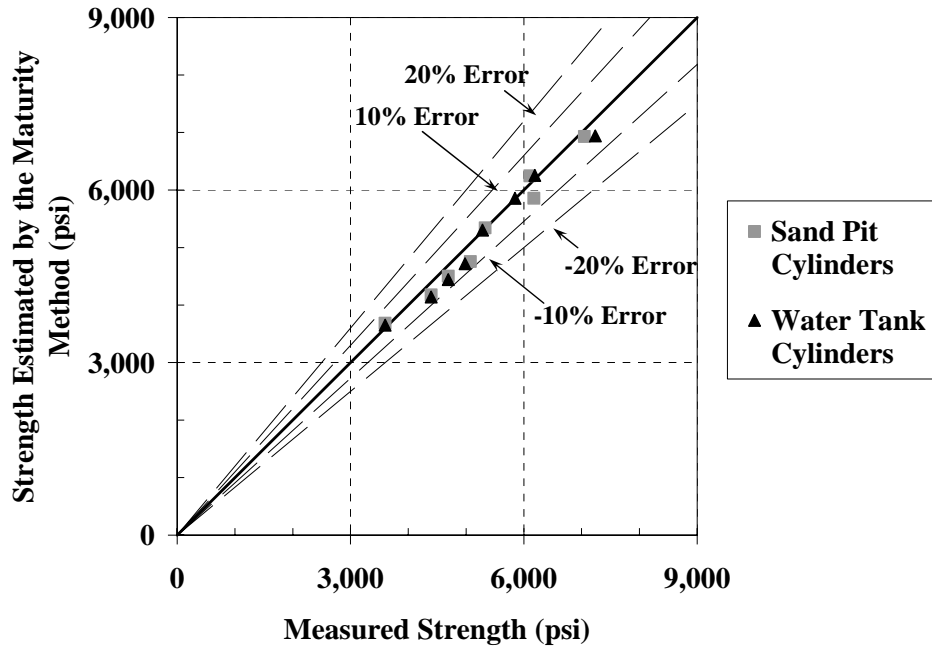

Figure 4-45: 45°-line graph for estimated cylinder strengths from the *laboratory* S-M relationship using the Arrhenius maturity function ($E = 33.5$ kJ/mol)

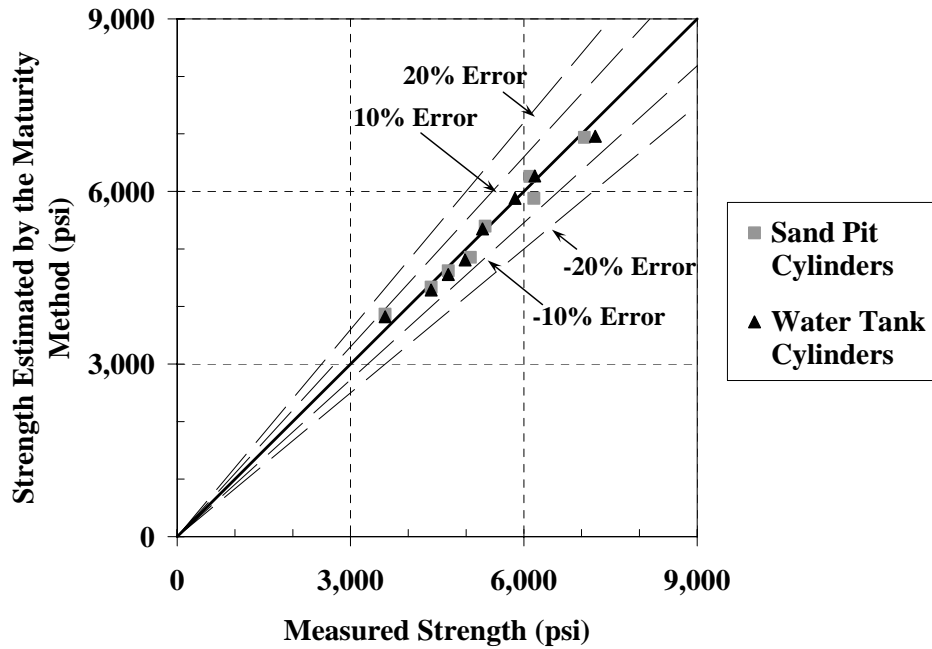

Figure 4-46: 45°-line graph for estimated cylinder strengths from the *laboratory* S-M relationship using the Arrhenius maturity function ($E = 40$ kJ/mol)

When the different datum temperatures were evaluated for the Nurse-Saul maturity function, the average absolute error was contained in a range from 348 to 437 psi. The average absolute error for the Nurse-Saul maturity function with datum temperature of 0 °C was slightly lower than the datum temperature of -10 °C, but not by much. The Arrhenius maturity function had the lowest average absolute errors for both the damp-sand-pit and water-tank data. The average absolute error for the Arrhenius maturity function with $E = 40$ kJ/mol was only about 20 psi less than that with $E = 33.5$ kJ/mol, which is not a great enough difference to indicate that one activation energy is “better” than the other. In summary, the *laboratory* S-M relationship using Arrhenius maturity functions estimated the strength of the field-cured cylinders more accurately than the Nurse-Saul maturity function.

The general trends can be identified by examining the 45°-line graphs and the percent errors given in Table 4-14. These show that the Arrhenius maturity functions tend to give a better estimation of the strength than the Nurse-Saul maturity functions. At early ages, the Nurse-Saul maturity function with a datum temperature of -10 °C underestimated the strength of the field-cured concrete by 10% or more. The datum temperature of 0 °C did underestimate the strength of the concrete but stayed within the 10% required with the exception of the 12-hour testing age. However, the Arrhenius maturity function for the *laboratory* S-M relationship estimates all three sets of cylinders within $\pm 10\%$ which indicates that the Arrhenius maturity function estimates the early-age strengths better than the Nurse-Saul maturity function.

In summary, the Arrhenius maturity method works well for estimating the cylinder strength for the different curing methods. The activation energy 40 kJ/mol was

the most accurate activation energy evaluated, although the activation energy of 33.5 kJ/mol was also accurate for estimating the strength. As for the Nurse-Saul maturity method, the datum temperature of -10 °C was not as accurate for estimating the strength of the field-cured specimens as the datum temperature of 0 °C. Only one testing age was not within the 10% range for the datum temperature of 0 °C. At this testing age, the strength of the concrete was underestimated, which is conservative and considered acceptable.

4.5.2 ACCURACY OF THE PULLOUT TABLE PROVIDED BY LOK-TEST SUPPLIER

Once the S-M relationships were evaluated and determined to provide accurate strength estimations, the in-place tests were evaluated. To determine if the pullout table supplied by Germann Instruments is accurate, the pullout cube data were analyzed as stated in Section 4.1.1.2. The pullout cubes were cured in the lime-saturated water-tank; therefore, compressive strengths that correlated to the pullout force from the pullout test tables were compared to the estimated strength from the *water-tank* S-M relationship at the same maturity. Since the Arrhenius maturity function with $E = 40$ kJ/mol and the Nurse-Saul maturity function with $T_0 = 0$ °C were found to be more accurate from Section 4.5.1, these two S-M relationships were used to evaluate the pullout table.

The estimated cylinder strengths from the *water-tank* S-M relationship and measured strengths from the pullout tables for the pullout cubes are presented in Appendix B. The percent errors calculated for the pullout cubes are presented in Table 4-15. In addition, the 45°-line graphs showing the cylinder strength estimated by the *water-tank* S-M relationship versus the strength from the pullout correlation table are presented

in Figure 4-47 to 4-48. 45°-line was added to the graph with 15% error lines. The other two 45°-line graphs for the Nurse-Saul maturity function with $T_o = -10\text{ }^\circ\text{C}$ and Arrhenius maturity function with $E = 33.5\text{ kJ/mol}$ are shown in Appendix B.

Table 4-15: Percent error for pullout cube strength from *water-tank* S-M relationship

Concrete Age (hours)	Nurse-Saul Function		Arrhenius Function	
	$T_o = -10\text{ }^\circ\text{C}$	$T_o = 0\text{ }^\circ\text{C}$	$E = 33.5\text{ kJ/mol}$	$E = 40\text{ kJ/mol}$
19.0	12%	11%	7%	5%
49.7	5%	5%	3%	2%
167.7	11%	11%	10%	10%

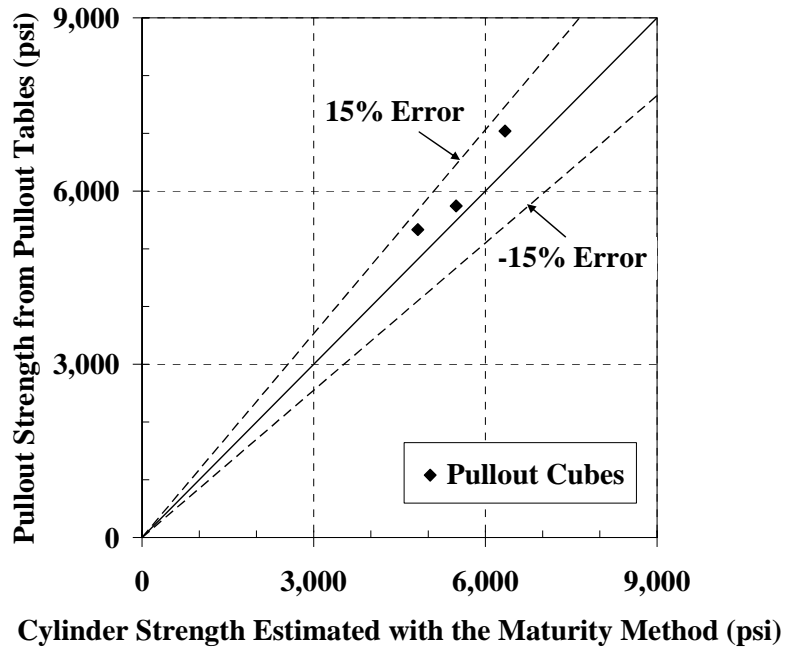

Figure 4-47: 45°-line graph to evaluate the pullout table using estimated strength from *water-tank* S-M relationship using the Nurse-Saul maturity function ($T_o = 0\text{ }^\circ\text{C}$)

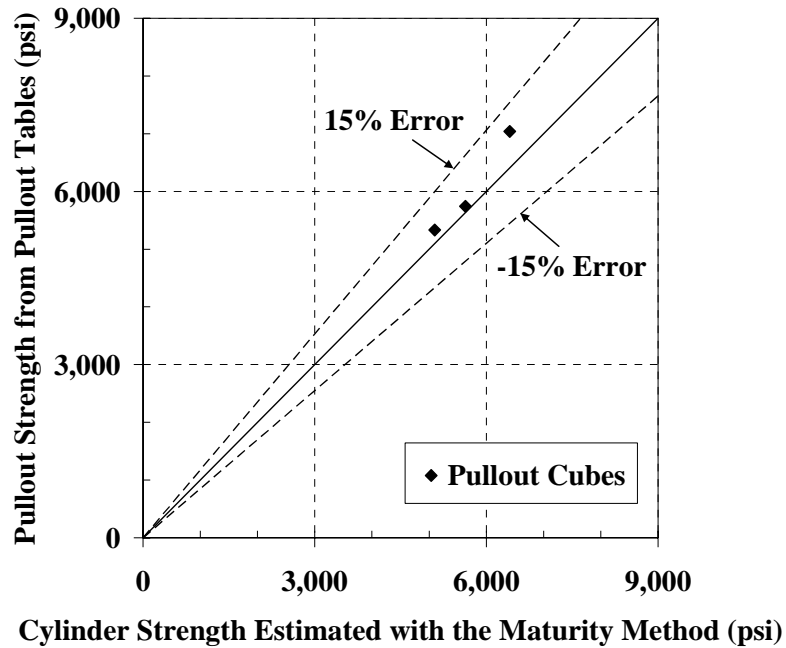

Figure 4-48: 45°-line graph to evaluate the pullout table using estimated strength from *water-tank* S-M relationship using the Arrhenius maturity function ($E = 40$ kJ/mol)

As stated in Section 4.3.5.5, if the pullout cubes exhibited a percent error of more than 15%, then the correlation table was considered invalid. When examining the percent errors for the pullout correlation table, none of the test ages showed errors greater than 15% for any of the four different *water-tank* S-M relationships. The largest percent error that occurred was 12%. Therefore, the correlation table was considered accurate for this concrete mixture and these strength levels. More testing will be conducted on the pullout cubes in other research phases to develop additional confidence in the use of the pullout correlation table.

4.5.3 ACCURACY OF THE MATURITY METHOD TO ASSESS IN-PLACE STRENGTH

Once the S-M relationships and the pullout table were concluded to be accurate, the evaluation of the in-place strength test was started. The in-place strength was quantified using the pullout test and compression testing of cores extracted from the mock girder. The acceptance criteria of 15% error was used, as stated in Section 4.3.5.5, for evaluating both testing methods. If the percent error differed by more than 15%, the maturity method was considered inaccurate to estimate the in-place strength.

4.5.3.1 Assessing the Estimated In-Place Strengths for the Pullout Test

First, the estimated strength from the *laboratory* S-M relationship was evaluated for the pullout test. Percent errors between the measured pullout strength and estimated strength from the *laboratory* S-M relationship are presented in Table 4-16. The average absolute percent error (Equation 4-3) was also calculated for the estimated in-place strength using the maturity method. The average absolute percent errors are located at the bottom of Table 4-16. The estimated pullout strengths from the *laboratory* S-M relationship for the individual pullout testing ages are presented in Appendix B. The 45°-line graphs that compare the measured pullout compressive strength to the estimated strength from the *laboratory* S-M relationship are shown in Figures 4-49 and 4-50. Graphs for the Nurse-Saul maturity function with $T_0 = 0\text{ }^{\circ}\text{C}$ and Arrhenius maturity function with $E = 40\text{ kJ/mol}$ are both shown in this section. The 45°-line and 15% error lines were added to the figures to help assess the accuracy of the maturity functions. The other 45°-line graphs showing the Nurse-Saul maturity function with $T_0 = -10\text{ }^{\circ}\text{C}$ and Arrhenius maturity function with $E = 33.5\text{ kJ/mol}$ are presented in Appendix B.

Table 4-16: Errors for pullout test using *laboratory* S-M relationship

	Concrete Age (hours)	Insert Location	Nurse-Saul Function		Arrhenius Function	
			T _o = -10 °C	T _o = 0 °C	E = 40 kJ/mol	E = 33.5 kJ/mol
Percent Difference	12.2	Top	-10%	-7%	13%	7%
		Side	1%	4%	25%	18%
	18.4	Top	-7%	-4%	11%	7%
		Side	-7%	-4%	10%	5%
	24.1	Top	-11%	-9%	3%	1%
		Side	-7%	-5%	8%	4%
49.2	Top	-6%	-4%	3%	0%	
	Side	-3%	-2%	6%	3%	
167.2	Top	-6%	-6%	-4%	-4%	
	Side	3%	3%	6%	5%	
671.2	Top	-16%	-16%	-15%	-15%	
	Side	4%	4%	5%	4%	
Average Absolute % Error	Top	9%	8%	8%	6%	
	Side	4%	4%	10%	7%	

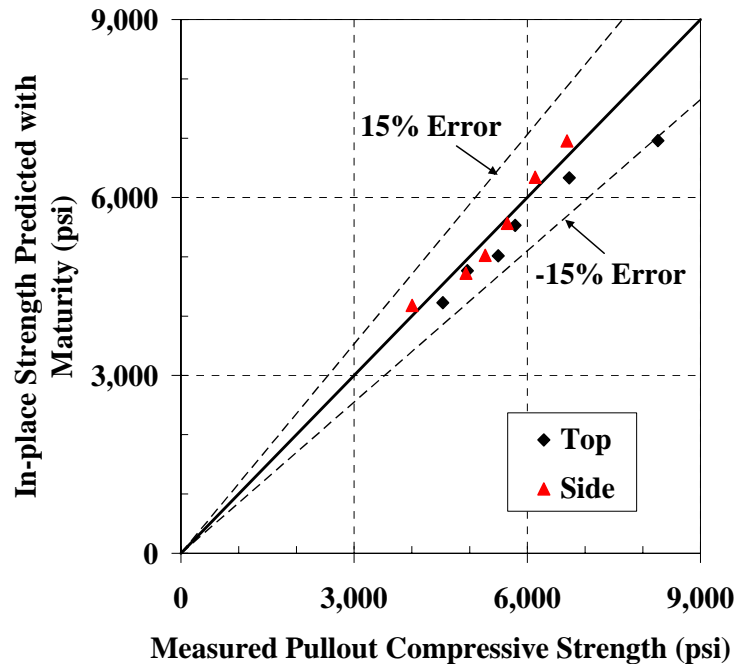

Figure 4-49: 45°-line graph for estimating the strength of pullout test on the mock girder using *laboratory* S-M relationship with Nurse-Saul maturity function (T_o = 0 °C)

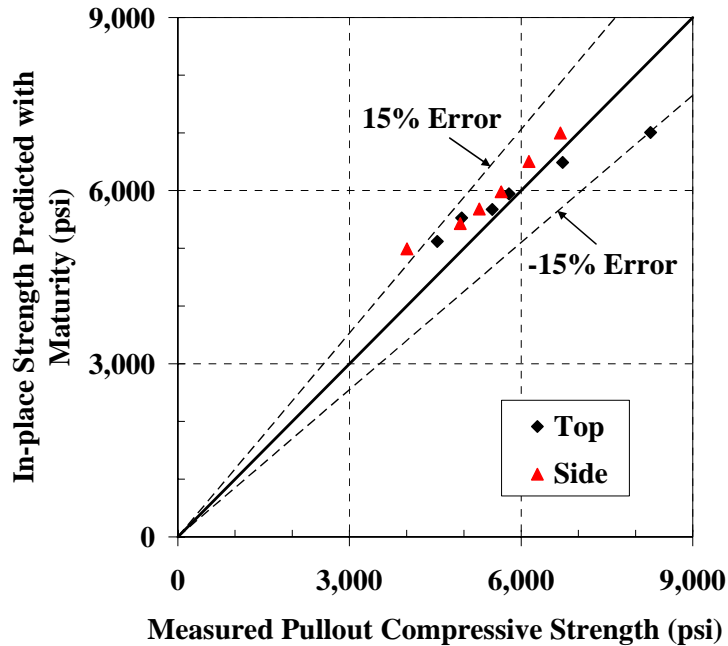

Figure 4-50: 45°-line graph for estimating the strength of pullout test on the mock girder using *laboratory* S-M relationship with Arrhenius maturity function ($E = 40$ kJ/mol)

When examining the percent errors for the pullout test using the *laboratory* S-M relationship, most of the errors are within 15%. However, the 28-day top pullout test exceeded the 15% criteria for all the maturity methods used, but not by much. This error can be attributed to multiple factors, but probably should not be considered as unacceptable because the side pullouts all lie within a 5% error for the Nurse-Saul maturity function. The higher error can possibly be attributed to the fact that only four inserts were tested at this age for the top because one of the inserts could not be tested due to an improper installation of the insert. Since the maturity method is especially useful to estimate early-age concrete strength, the accuracy of the method up to the equivalent age of 7 days is of more importance.

When only the data up to 7 days are considered, the maximum error is only 11% for the Nurse-Saul maturity function. This error is very reasonable. When evaluating the average absolute percent error, the difference between the two datum temperatures for the Nurse-Saul maturity method is very small. No definitive conclusion can be made on which datum temperature is better based on the average absolute percent errors. However, it should be noted that the range for the percent error for the datum temperature of 0 °C never exceeds 10% for the first 7 days whereas the datum temperature of -10 °C has a percent error of -11% for the 24-hour test.

The only errors that were not within the 15% range, besides the 28-day top pullout test, were the Arrhenius maturity function errors for the side pullout tests at the age of 12 hours. The error was overestimated by 25% and 18%, these errors but only occurred for the Arrhenius maturity function, whereas the Nurse-Saul maturity function estimated the strength very well with the error staying below 5%. When considering the early-age estimation of strength, the Arrhenius maturity function with $E = 40$ kJ/mol estimated the in-place strength the worst. The average absolute percent errors for $E = 33.5$ kJ/mol were 6% and 7% for the top and side pullout test, respectively, whereas the average absolute percent errors for $E = 40$ kJ/mol were 8% and 10%. These errors indicate that the activation energy of 33.5 kJ/mol estimates the in-place strength more accurately.

The Nurse-Saul maturity function was the most accurate function for estimating the in-place strength using the *laboratory* S-M relationship. The Nurse-Saul maturity function with $T_o = 0$ °C predicted the in-place strength slightly better than $T_o = -10$ °C.

The Arrhenius maturity function with $E = 33.5$ kJ/mol also estimated the in-place strengths fairly well with the exception of the 12-hour side pullout test.

Next, the in-place strengths were evaluated using the *water-tank* and *sand-pit* S-M relationships. The percent errors and average absolute percent errors are presented in Table 4-17 for the *water-tank* S-M relationship. The 45°-line graphs that show the measured in-place compressive strengths and the estimated strengths from the *water-tank* S-M maturity relationship are presented in Figures 4-51 to 4-52. Graphs for the Nurse-Saul maturity function with $T_o = 0$ °C and Arrhenius maturity function with $E = 40$ kJ/mol are presented in this section. The other graphs for estimating the strength with the *water-tank* S-M relationship with the Nurse-Saul maturity function with $T_o = -10$ °C and Arrhenius maturity function with $E = 33.5$ kJ/mol are presented in Appendix B. Also located in Appendix B are the estimated pullout compressive strengths from the *water-tank* and *sand-pit* S-M relationships.

Table 4-17: Percent errors for pullout test using *water-tank* S-M relationship

	Concrete Age (hours)	Insert Location	Nurse-Saul Function		Arrhenius Function	
			T _o = -10 °C	T _o = 0 °C	E = 40 kJ/mol	E = 33.5 kJ/mol
Percent Difference	12.2	Top	-1%	0%	13%	8%
		Side	11%	13%	25%	20%
	18.4	Top	-1%	0%	12%	8%
		Side	-2%	0%	10%	7%
	24.1	Top	-7%	-6%	4%	0%
		Side	-3%	-1%	8%	5%
	49.2	Top	-4%	-3%	3%	1%
		Side	-1%	0%	6%	4%
	167.2	Top	-5%	-4%	-2%	-3%
		Side	4%	5%	8%	7%
	671.2	Top	-13%	-13%	-13%	-13%
		Side	7%	7%	8%	8%
Average Absolute % Error	Top	5%	4%	8%	6%	
	Side	5%	4%	11%	8%	

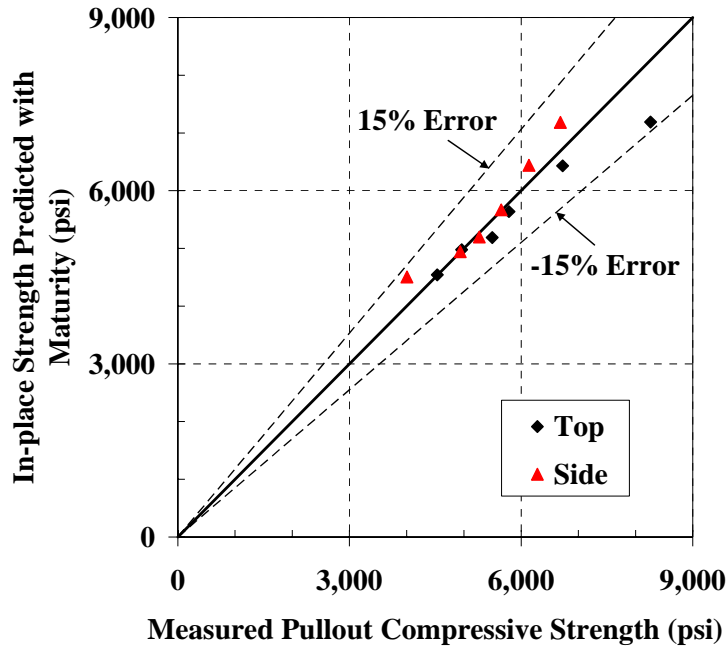

Figure 4-51: 45°-line graph for estimating the strength of pullout test on the mock girder using *water-tank* S-M relationship with Nurse-Saul maturity function (T_o = 0 °C)

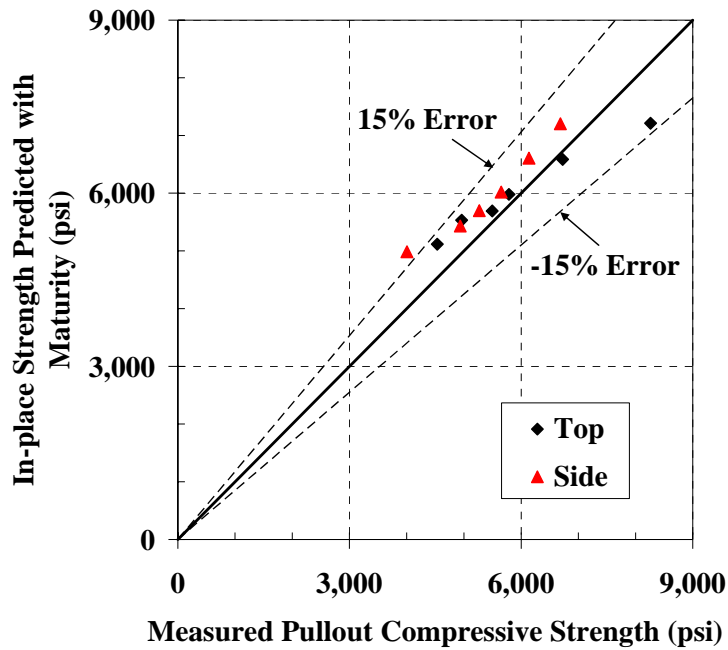

Figure 4-52: 45°-line graph for estimating the strength of pullout test on the mock girder using *water-tank* S-M relationship with Arrhenius maturity function ($E = 40$ kJ/mol)

The sand-pit percent errors and average absolute errors are listed in Table 4-18. Graphs showing the 45°-line for the estimated pullout strength from the *sand-pit* S-M relationship versus the measured strength from the in-place pullout testing are presented in Figures 4-53 and 4-54. The Nurse-Saul maturity method with $T_0 = 0$ °C is presented in Figure 4-53, and the Arrhenius maturity function with $E = 40$ kJ/mol is presented in Figure 4-54. The other Nurse-Saul maturity function with $T_0 = -10$ °C and the Arrhenius maturity function with $E = 33.5$ kJ/mol are presented in Appendix B.

Table 4-18: Percent errors for pullout test using *sand-pit* S-M relationship

	Concrete Age (hours)	Insert Location	Nurse-Saul Function		Arrhenius Function	
			$T_0 = -10\text{ }^\circ\text{C}$	$T_0 = 0\text{ }^\circ\text{C}$	$E = 40\text{ kJ/mol}$	$E = 33.5\text{ kJ/mol}$
Percent Difference	12.2	Top	0%	1%	15%	10%
		Side	12%	13%	26%	22%
	18.4	Top	1%	2%	14%	10%
		Side	0%	2%	12%	9%
	24.1	Top	-5%	-4%	5%	2%
		Side	-1%	1%	10%	7%
49.2	Top	-2%	-1%	5%	3%	
	Side	1%	2%	8%	6%	
167.2	Top	-5%	-4%	-2%	-3%	
	Side	5%	5%	7%	7%	
671.2	Top	-16%	-16%	-15%	-16%	
	Side	4%	4%	4%	4%	
Average Absolute % Error	Top	5%	5%	9%	7%	
	Side	4%	5%	11%	9%	

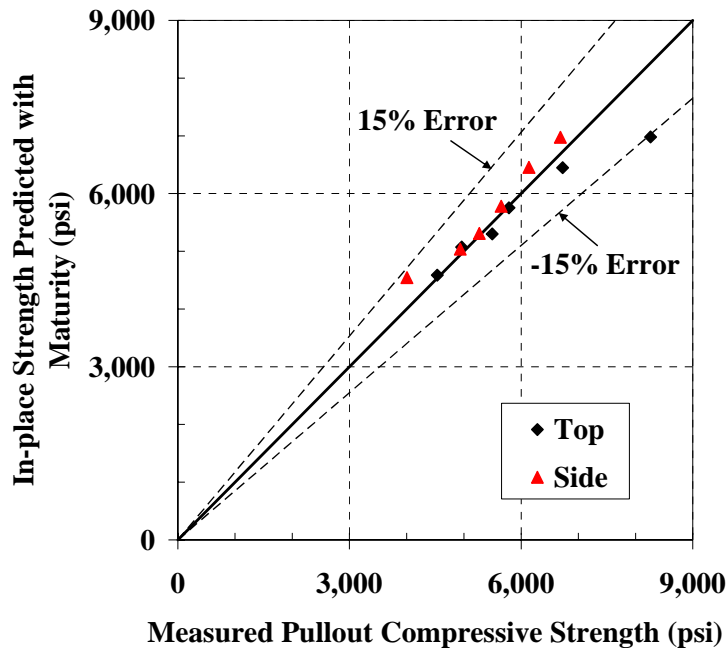

Figure 4-53: 45°-line graph for estimating the strength of pullout test on the mock girder using *sand-pit* S-M relationship with Nurse-Saul maturity function ($T_0 = 0\text{ }^\circ\text{C}$)

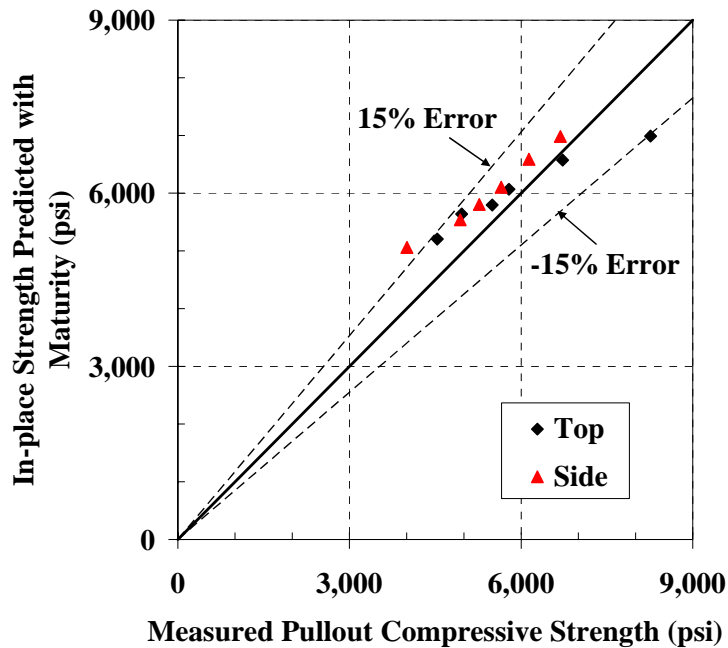

Figure 4-54: 45°-line graph for estimating the strength of pullout test on the mock girder using *sand-pit* S-M relationship with Arrhenius maturity function ($E = 40$ kJ/mol)

When examining the percent errors and 45°-line graphs for all the S-M relationships, one of the trends that was evident was that the 28-day top pullout strengths were underestimated for all S-M relationships, while all the side pullout strengths were estimated fairly accurately. The percent errors for the 28-day top pullout strength ranged between -13% to -16%. The same trend also occurred in the percent errors when the pullout strength was estimated from the *laboratory* S-M relationship. This high percentage error and the fact that the side pullout was well estimated indicates that the test results recorded for the 28-day top pullout might have been collected or recorded wrongly. Due to the inaccuracy shown for the 28-day top pullout test and the fact that the

maturity method is mainly used for early-age strengths, the 28-day top pullout test results will not be considered in analyzing the accuracy of the maturity method.

The Nurse-Saul maturity function for the *water-tank* S-M relationship tended to estimate the in-place strength most accurately. For this method, all the percent errors, for testing up to 7 days, ranged from -7% to 13%. A clear distinction on which datum temperature gave more accurate results could not be concluded, due to the small difference in percent error between the two. The small average absolute percent error also indicates that both datum temperatures estimated the strength very accurately. The average absolute percent error was only 4% and 5% for both datum temperatures.

When all the *water-tank* S-M relationships were considered, all of the percent errors were within the 15% range, with the exception of the Arrhenius maturity function side pullout test estimates. Generally, the activation energies for Arrhenius maturity functions using the *water-tank* S-M relationship overestimated the strength for the 12 hour test by more than 15%. On the other hand, both the Nurse-Saul maturity functions overestimated the strength by no more than 13% for all the tests. In addition, the average absolute percent error for the Arrhenius maturity function was higher than the Nurse-Saul maturity function. In general, for the *water-tank* S-M relationships, the Nurse-Saul maturity functions were the most accurate for estimating the in-place pullout strength.

The same trends that occurred in the *water-tank* S-M relationship occurred in the *sand-pit* S-M relationship. Most of the percent errors lay within 15%, with the exception of the 28-day top pullout test for all maturity functions and the 12-hour side pullout test for the Arrhenius maturity functions. Again, the Nurse-Saul maturity function was the most accurate S-M relationship. For the first seven days, the percent errors for this

function ranged from -5% to 13%. The difference between $T_o = 0\text{ }^\circ\text{C}$ and $T_o = -10\text{ }^\circ\text{C}$ was very small, and it could not be determined which datum temperature provided the most accurate estimate. As for the Arrhenius maturity function, $E = 33.5\text{ kJ/mol}$ was more accurate than $E = 40\text{ kJ/mol}$. With the exception of the 12-hour test, the percent errors for the first 7 days of the Arrhenius maturity function with $E = 33.5\text{ kJ/mol}$ were 10% or less, whereas the percent errors for the first seven days of the $E = 40\text{ kJ/mol}$ function were as high as 15%.

Generally, both *field-cured* S-M relationships using the Nurse-Saul maturity function tended to estimate the strength very well. The Arrhenius maturity function using $E = 33.5\text{ kJ/mol}$ was the better of the two activation energies being evaluated. When determining which curing method was the most accurate, the average absolute percent error was used. There was very little difference between the two field-curing methods. However, for the Nurse-Saul maturity function, the average absolute percent error was smaller for the two *field-cured* S-M relationships than for the *laboratory* S-M relationship. The average absolute percent error was 4% to 5% for the field-curing condition versus 4% to 9% for the laboratory-curing condition. This indicates that the field-curing condition estimates the in-place strength more accurately for the Nurse-Saul maturity function. For the Arrhenius maturity function, the average absolute error was 7% to 11% for the field-curing condition, and 6% to 11% for the laboratory-curing condition. No definitive conclusion can be made on whether the field or laboratory-curing condition estimated the in-place strength more accurately for the Arrhenius maturity function.

In summary, the in-place strength for the pullout test was estimated accurately with the Nurse-Saul maturity function. The maturity function of Nurse-Saul using $T_o = 0$ °C was the slightly better maturity function for estimating the in-place strength. The Arrhenius maturity function with $E = 33.5$ kJ/mol was also a good maturity function for estimating the in-place strength. As for the comparison of the different S-M relationships, the data support the conclusion that the *water-tank* and *sand-pit* S-M relationships provided the most representative strength-maturity data for estimating the in-place strength. The estimated strengths from *laboratory* S-M relationship are within the acceptable tolerance, but the estimated strengths from the *field-cured* S-M relationships were slightly more accurate. It should be noted that there was no cross-over effect which was not expected, and therefore both *laboratory* and *field cured* S-M relationships were accurate at estimating the in-place strength. A further evaluation of whether the *field-cured* S-M relationship will estimate the in-place strength more accurately than the *laboratory* S-M relationship will be conducted in the bridge deck project.

4.5.3.2 Assessing the Estimated In-Place Strengths for the Testing of Cores

Next, the accuracy of the maturity method for estimating the compressive strength of cores was evaluated. As stated in Section 2.8.3, the compressive strengths of cores have been a debated testing method because cores tend to exhibit lower strengths than the in-place concrete strength (Bloem 1965). All estimated strengths for the compressive strengths of the cores from the four maturity methods and three curing methods are presented in Appendix B.

The percent errors and average absolute percent errors for the core strength data using the *laboratory* S-M relationship are presented in Table 4-19. The 45°-line graphs showing the estimated strength versus the measured strength for the Nurse-Saul maturity function with $T_o = 0\text{ }^\circ\text{C}$ and Arrhenius maturity function with $E = 40\text{ kJ/mol}$ are presented in Figures 4-55 and 4-56. The maturity method using these S-M relationships overestimated the core strength by 14% to 28%. These results may indicate that the strength of the cores were low as compared to the pullout test results.

Table 4-19: Percent errors for core test using *laboratory* S-M relationship

	Concrete Age (Days)	Curing Method	Nurse-Saul Function		Arrhenius Function	
			$T_o = -10\text{ }^\circ\text{C}$	$T_o = 0\text{ }^\circ\text{C}$	$E = 40\text{ kJ/mol}$	$E = 33.5\text{ kJ/mol}$
<i>Percent Difference</i>	7.0	ASTM C 42	19%	17%	22%	21%
		AASHTO T 24	24%	23%	28%	27%
	28.0	ASTM C 42	14%	14%	15%	14%
		AASHTO T 24	17%	18%	18%	18%
<i>Average Absolute % Error</i>		ASTM C 43	16%	15%	18%	17%
		AASHTO T 25	21%	20%	23%	22%

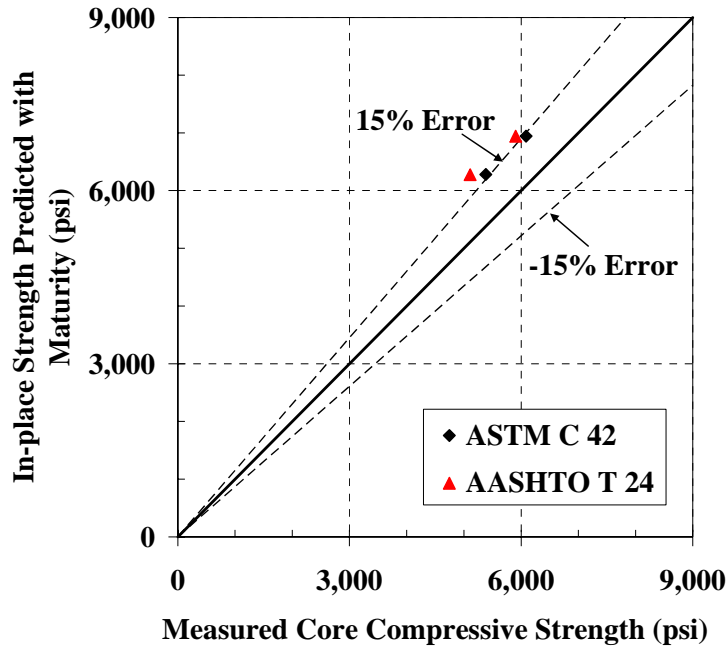

Figure 4-55: 45°-line graph for estimating the strength of cores for the mock girder using *laboratory* S-M relationship with Nurse-Saul maturity function ($T_0 = 0\text{ }^{\circ}\text{C}$)

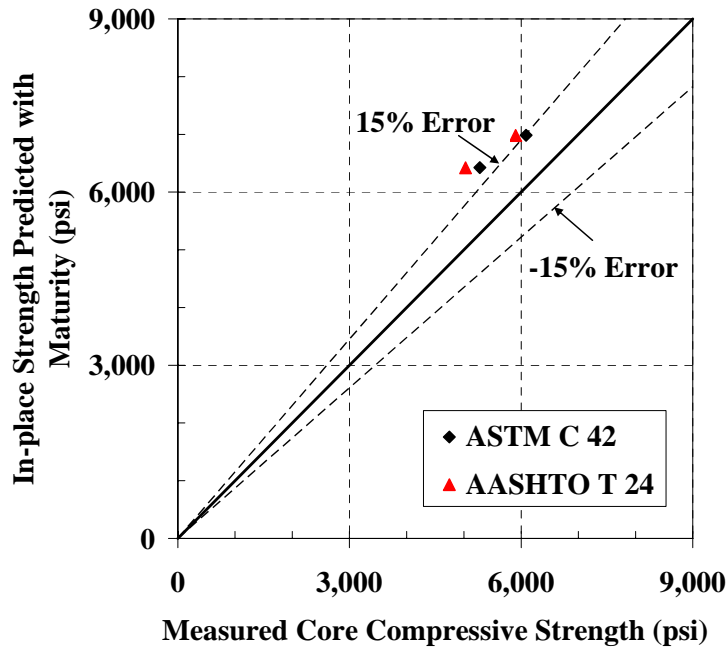

Figure 4-56: 45°-line graph for estimating the strength of cores for the mock girder using *laboratory* S-M relationship with Arrhenius maturity function ($E = 40\text{ kJ/mol}$)

All of the cores' strengths are overestimated by the maturity method. The Nurse-Saul maturity function tended to estimate the strengths better than the Arrhenius maturity function for the 7-day test. The percent error ranged from 17% to 24% for the Nurse-Saul maturity function and 21% to 28% for the Arrhenius maturity function. As for the 28-day test, the percent errors ranged from 14% to 18% for both maturity functions. The average absolute percent error was about the same for the different maturity functions.

The strength data of the cores were also compared to the estimated strengths from the *water-tank* and *sand-pit* S-M relationships to see if they would provide a better estimate of in-place strength. The percent errors for the *water-tank* and *sand-pit* S-M relationships are presented in Tables 4-20 and 4-21. The 45°-line graphs showing the measured strengths and estimated strengths from the *water-tank* and *sand-pit* S-M relationships are presented in Figures 4-57 to 4-60. The Nurse-Saul maturity function with $T_0 = 0\text{ }^\circ\text{C}$ and Arrhenius maturity function with $E = 40\text{ kJ/mol}$ are presented in this section. The Nurse-Saul maturity function with $T_0 = -10\text{ }^\circ\text{C}$ and Arrhenius maturity function with $E = 33.5\text{ kJ/mol}$ are presented in Appendix B.

Table 4-20: Percent errors for core test using *water-tank* S-M relationship

	Concrete Age (Days)	Curing Method	Nurse-Saul Function		Arrhenius Function	
			$T_0 = -10\text{ }^\circ\text{C}$	$T_0 = 0\text{ }^\circ\text{C}$	$E = 40\text{ kJ/mol}$	$E = 33.5\text{ kJ/mol}$
<i>Percent Difference</i>	7.0	ASTM C 42	20%	18%	23%	22%
		AASHTO T 24	26%	25%	29%	28%
	28.0	ASTM C 42	18%	18%	18%	18%
		AASHTO T 24	21%	21%	22%	21%
<i>Average Absolute % Error</i>		ASTM C 43	19%	18%	21%	20%
		AASHTO T 25	24%	23%	26%	25%

Table 4-21: Percent errors for core test using *sand-pit* S-M relationship

	Concrete Age (Days)	Curing Method	Nurse-Saul Function		Arrhenius Function	
			$T_o = -10\text{ }^\circ\text{C}$	$T_o = 0\text{ }^\circ\text{C}$	E = 40 kJ/mol	E = 33.5 kJ/mol
<i>Percent Difference</i>	7.0	ASTM C 42	21%	19%	23%	23%
		AASHTO T 24	27%	25%	30%	29%
	28.0	ASTM C 42	14%	14%	15%	14%
		AASHTO T 24	18%	18%	18%	18%
<i>Average Absolute % Error</i>	ASTM C 43	18%	17%	19%	19%	
	AASHTO T 25	22%	22%	24%	23%	

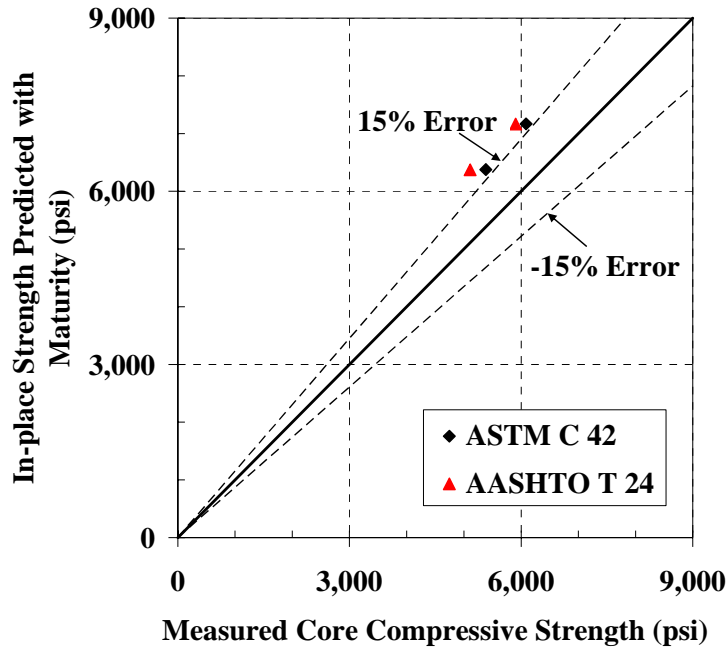

Figure 4-57: 45°-line graph for estimating the strength of cores for the mock girder using *water-tank* S-M relationship with Nurse-Saul maturity function ($T_o = 0\text{ }^\circ\text{C}$)

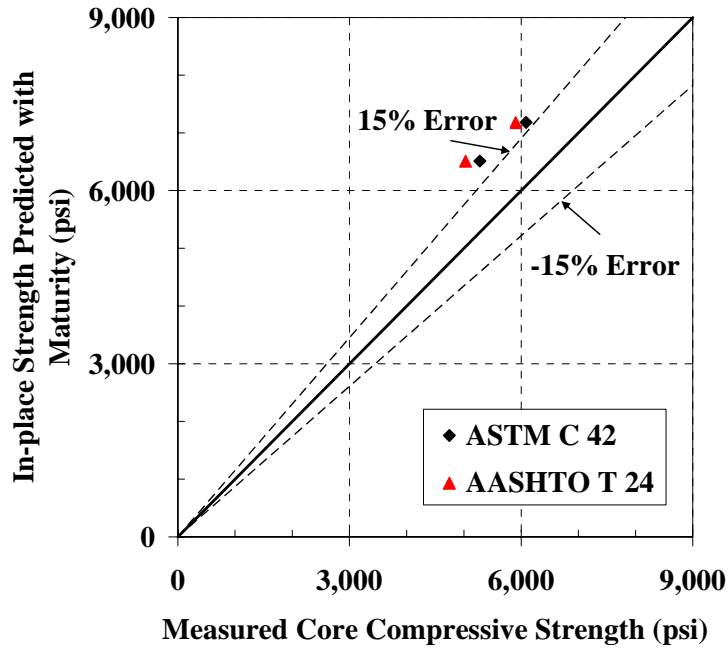

Figure 4-58: 45°-line graph for estimating the strength of cores for the mock girder using *water-tank* S-M relationship with Arrhenius maturity function ($E = 40$ kJ/mol)

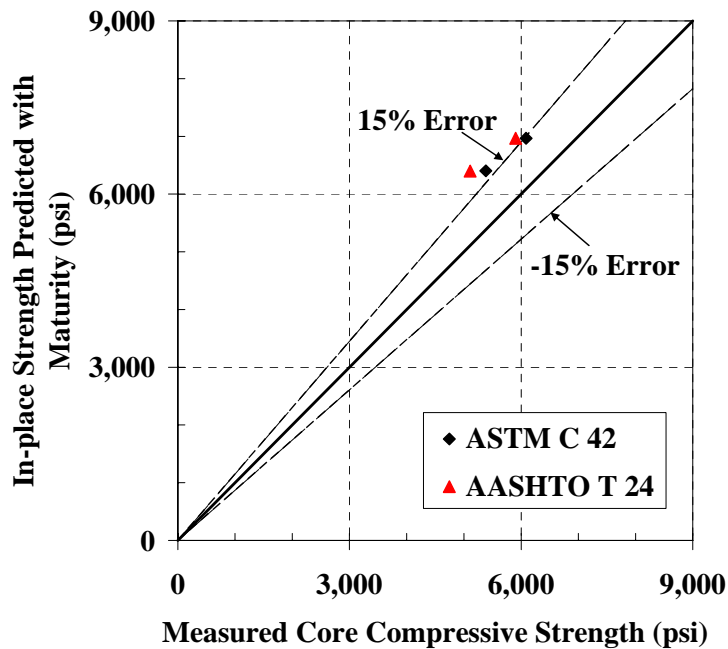

Figure 4-59: 45°-line graph for estimating the strength of cores for the mock girder using *sand-pit* S-M relationship with Nurse-Saul maturity function ($T_0 = 0$ °C)

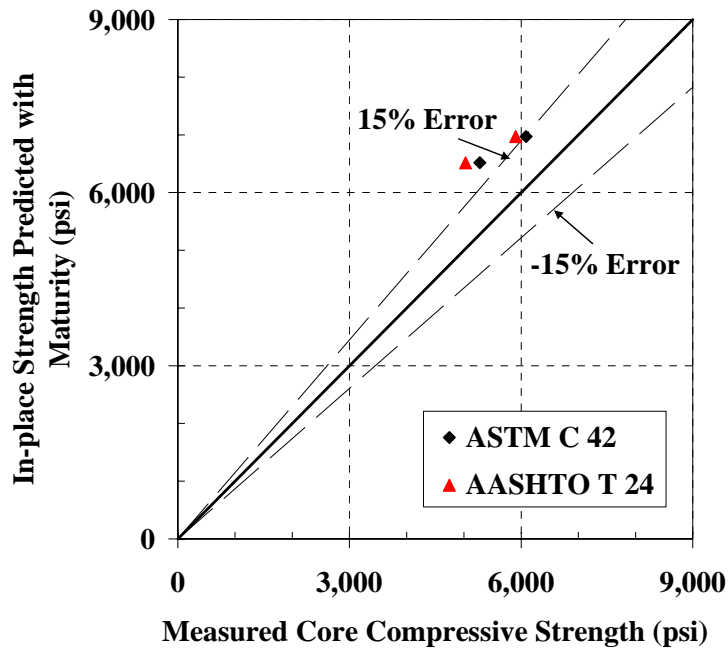

Figure 4-60: 45°-line graph for estimating the strength of cores for the mock girder using *sand-pit* S-M relationship with Arrhenius maturity function ($E = 40$ kJ/mol)

Again, the same trends that occurred in the 45°-line graphs for laboratory results can be identified for the water-tank and sand-pit plots. All of the percent errors were greater than 15%, except for some of the 28-day results of the ASTM C 42 curing method for the strengths estimated from the *sand-pit* S-M relationship. The Nurse-Saul maturity function estimated the strength a little better than the Arrhenius maturity function for the 7 day testing age. For the Nurse-Saul maturity function, the percent errors ranged from 19% to 27% for the strengths estimated from the *sand-pit* S-M relationship and 18% to 26% for the 7-day strengths estimated from *water-tank* S-M relationship. For the Arrhenius maturity function, the percent errors ranged from 23% to 30% for the 7-day strengths estimated from the *sand-pit* S-M relationship and 22% to 29% for the 7-day

strengths estimated from *water-tank* S-M relationship. As for the 28-day testing age there was very little difference in the percent errors of the Arrhenius maturity function and Nurse-Saul maturity function.

As for the differences in the two core curing methods, the strength differences were minimal and both curing methods consistently highly overestimated the core strength. The maturity method did not estimate the core strength accurately for any of the curing methods. The discrepancies between the core strengths and the pullout test results tend to indicate that the core strengths were most likely lower than the actually in-place strength, and that this does not mean that the maturity method did not work well for estimating the in-place strength.

A comparison of the compression strength of the pullout test to the cores can be seen in Figure 4-61. The 7- and 28-day testing ages are shown for both tests. The maturities for the pullout test and cores were not exactly the same but were within 10% of one another. The results of the compression testing of the cores did not correspond well to the compression strengths of the pullout test at the same ages. The core strengths were an average approximately 1,000 psi lower for the 7-day test and approximately 1,300 psi lower for the 28-day test.

When evaluating the average absolute percent errors, the ASTM C 42 curing method tended to have a lower error by 4% to 5% than the AASHTO T 24 curing method. The ASTM C 42 method and AASHTO T 24 curing methods do not show enough evidence to conclude which method is more accurate. In fact, the strengths for the two different curing methods were very close, which can be seen in Figures 4-55 and 4-56.

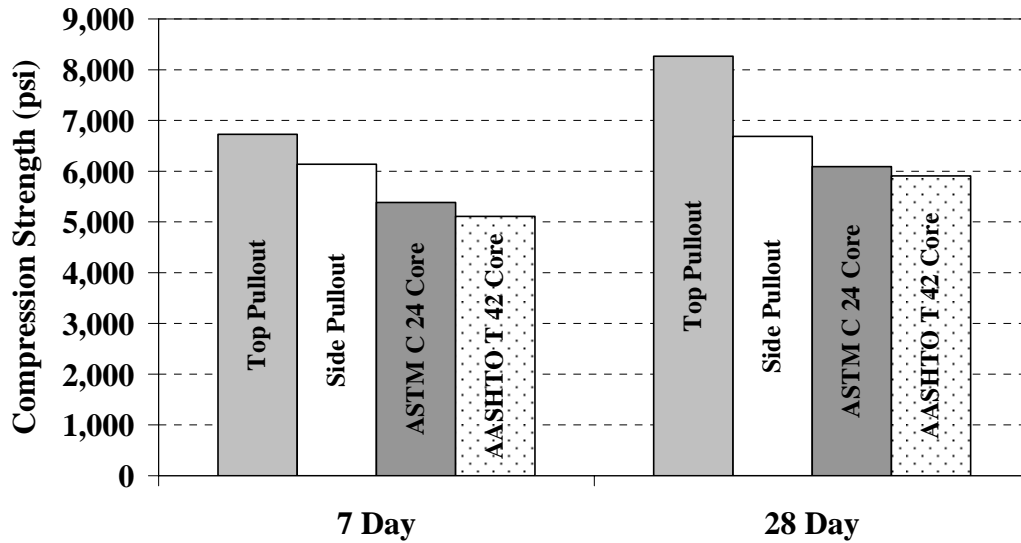

Figure 4-61: Compressive strength from the pullout test versus the cores for the 7- and 28-day testing ages

4.5.3.3 Summary of Accuracy of In-place Strengths

In summary, the maturity method provided accurate estimates of the in-place strength as measured by pullout testing. The compressive strengths of the cores were not estimated well by any of the maturity methods evaluated. This inaccuracy was probably due to the fact that the core strengths were low compared to the pullout test. The results are in agreement with the findings of other researchers who state that cores do not provide an accurate assessment of in-place strength. Therefore, the inaccuracy of the maturity method for assessing the strength of cores was discounted when evaluating the ability of the maturity method to estimate the in-place strength of concrete.

4.5.4 EVALUATION OF THE TESTING SCHEDULE

When developing the testing schedule for the molded cylinders for the prestressed girder project, many test ages were employed because there was an uncertainty of how many ages were needed to capture the strength development of concrete made with Type III cement. Ideally, the number of testing ages should be the minimum number that will capture the strength development of the concrete. Since the *field-cured* S-M relationships were more accurate relationships for estimating the in-place strength, the testing schedule that was used for the field-cured specimens was evaluated.

In order to capture the strength development of the concrete, a minimum of two testing ages should fall on the initial slope of the strength development curve. Also at least one of the testing ages should be in the area of the curve where the strength development starts to transition from a high rate of strength development to the slower rate. One of the testing ages should be around 7 days because the maturity method is usually only used to provide early-age strength estimates. Finally, a 28-day test should be performed for two reasons: (1) to help obtain an estimate of the ultimate strength (S_u) needed for the exponential function, and (2) to ensure that the concrete produced for the strength-maturity relationship meets the 28-day strength requirements of the concrete for precast prestressed girder operations.

The testing schedule that was established for the prestressed girder field study included tests at 8, 12, 18, and 24 hours and 2, 4, 7 and 28 days. The strength development of the concrete used for the prestressed field project and the testing schedule can be seen in Figure 4-62.

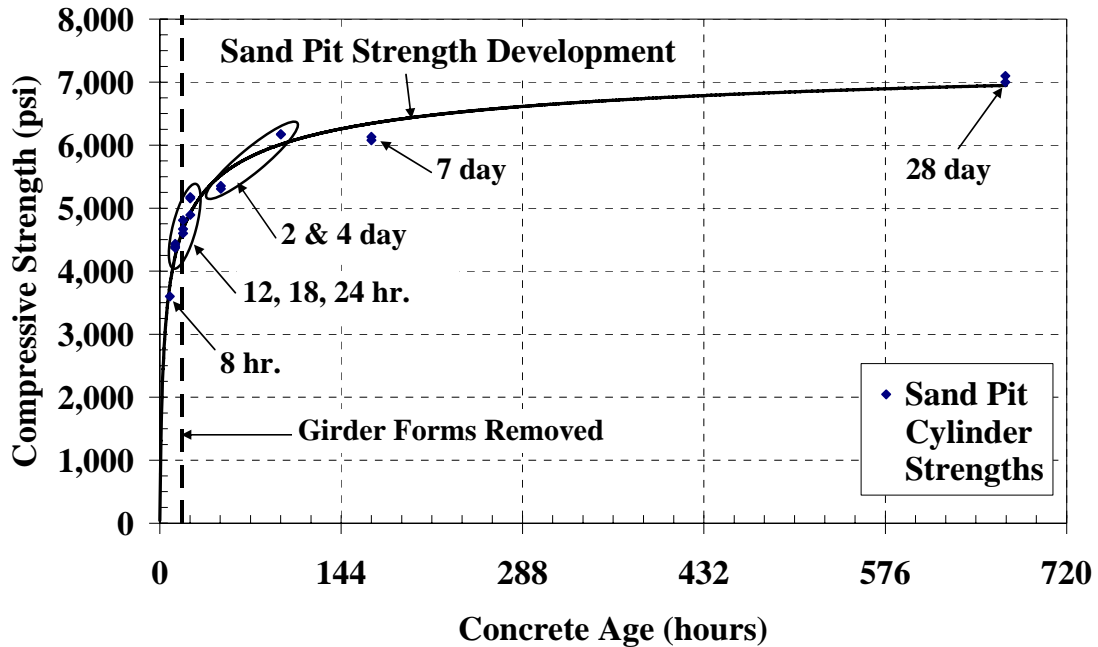

Figure 4-62: Evaluation of the testing ages for the prestressed girder project

Another earlier testing age before the first 8 hour test could have been conducted to better capture the initial strength development. Therefore, it is recommended that a testing age of 6 hours, instead of 8-hours, be used to help capture the initial strength gain of the concrete. As for the next three testing ages, 12, 18, and 24 hours, only two of these testing ages are needed since strengths are fairly close to one another. On average, the release of the prestressed strands was conducted at about 18 hours at the Sherman Prestress plant. It would be beneficial for the testing ages to bracket the release time. The strength and maturity data that would be collected at these ages would help when using the strength-maturity relationship to estimate the concrete strength. Inclusion of a test age in the transition area from the initial strength development to the slower strength development at day 2 or 3 would be adequate. The test age at 4 days seem to be too far from the transitional point to be beneficial. Finally, the 7 and 28 day testing ages should

be conducted to help define the strength plateau of the concrete. Therefore, the final recommended testing schedule for the precast prestressed operations is to test at 6, 12, and 24 hours, and 3, 7, and 28 days. These ages correspond to equivalent ages of 8, 40, and 83 hours, and 5, 9, and 30 days when $E = 33.5$ kJ/mol is used to compute the equivalent age with the assumed temperature history.

4.5.5 EVALUATION OF THE MATURITY METHOD WITH CONFIDENCE LEVELS

The strengths of the concrete for the cylinders, pullout tests, and core strength tests relating to several confidence levels were calculated for each type of test result using the coefficients of variation and the K values in Table 2-4 that corresponded to the number of tests being performed. The estimated strengths at confidence levels of 50%, 75%, and 90% were calculated as stated in Section 4.3.5.5. Confidence levels only need to be considered if critical construction sequence requires that a specific strength be reached before proceeding with further construction. The more critical the concrete process, the higher the required confidence level.

The prestressed girder construction process is usually controlled by the tensioning and release of the strands. A specific concrete strength is required before the strands can be cut and the prestressed force transferred to the concrete. ALDOT Standard Specification (2002) requires that when the *average* strength of two cylinders reaches the specified strength, the prestressed strand can be cut. This means that prestressed concrete plants use an average strength, which corresponds to a 50% confidence level with a defective level equal to 50%, not the 10% from which the f'_c data is determined.

Consideration of confidence levels with a 10% defect level ensures that 90% of the strengths estimated with the maturity method tested are above the required strength at the applied confidence level. Therefore, when the strength estimated with the maturity method is verified, there will be a 90% chance that the specified strength is reached. When examining the confidence level S-M relationships (Figures 4-31 to 4-42) for the in-place pullout strength data, the confidence level of 50% seems adequate to ensure that the measured concrete strengths fall above the S-M relationship. Since prestressed girder production has a high degree of control, it is not surprising that the measured test results were very close to the original S-M relationship developed from the average of the both the laboratory and field-cured cylinders. Not all the strength test results were above the S-M relationship developed for a 50% confidence level, but most of the results were. Use of a 75% confidence level would require the fabricator to wait additional time to guarantee that a certain strength be achieved, which could result in delays in the production process. One possible reason that most concrete strengths fell above the 50% confidence level is that all the concrete tested was from one batch of concrete and it would be expected that this condition would result in a low variability.

It is recommended that the 50% confidence level S-M relationship be used to estimate the strength of concrete used for prestressed precast girders. An example of this estimation process is illustrated in Figure 4-63. If the specified strength at transfer of prestressed force was 4,400 psi, then the verification test would be preformed at a maturity index of $675\text{ }^{\circ}\text{C} \cdot \text{hours}$. Testing at this maturity value would ensure that the estimated strength of 4,400 psi corresponds to a 10% defect level, so that there is a 90% chance the estimated strength should be above 4,400 psi.

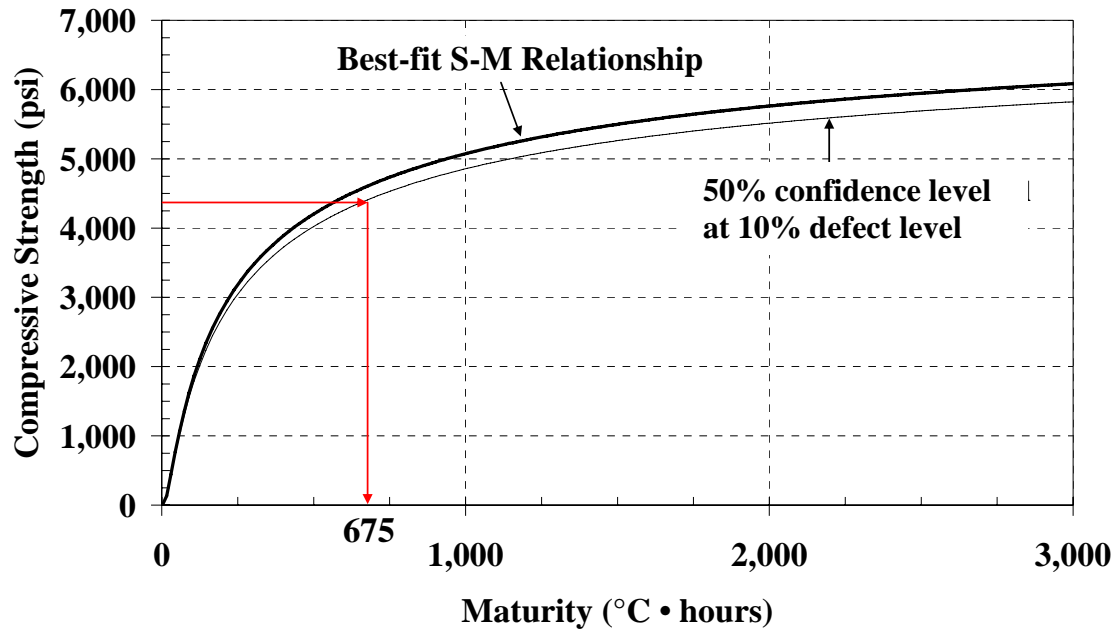

Figure 4-63: 50% confidence level S-M relationship for the prestressed girder project

4.5.6 EVALUATION OF THE TEMPERATURE PROFILE OF THE MOCK GIRDER

One of the objectives of the prestressed field project was to evaluate the most appropriate locations for installation of temperature sensors. To determine the potential locations for the temperature sensors, two of factors were considered. The first factor depends on the possibility that in-place testing will be performed along with the use of the maturity method. To properly use the maturity method, the temperature sensors should be installed near the location where the in-place testing will be conducted. This ensures that the most representative temperature history will be used for maturity calculations at locations of in-place testing.

If the maturity method is to be used with concrete cylinders to verify the estimated strength, then the location of the temperature probe will be critical. Figure 4-64 shows the temperature variation that can occur within a typical cross section in the girder.

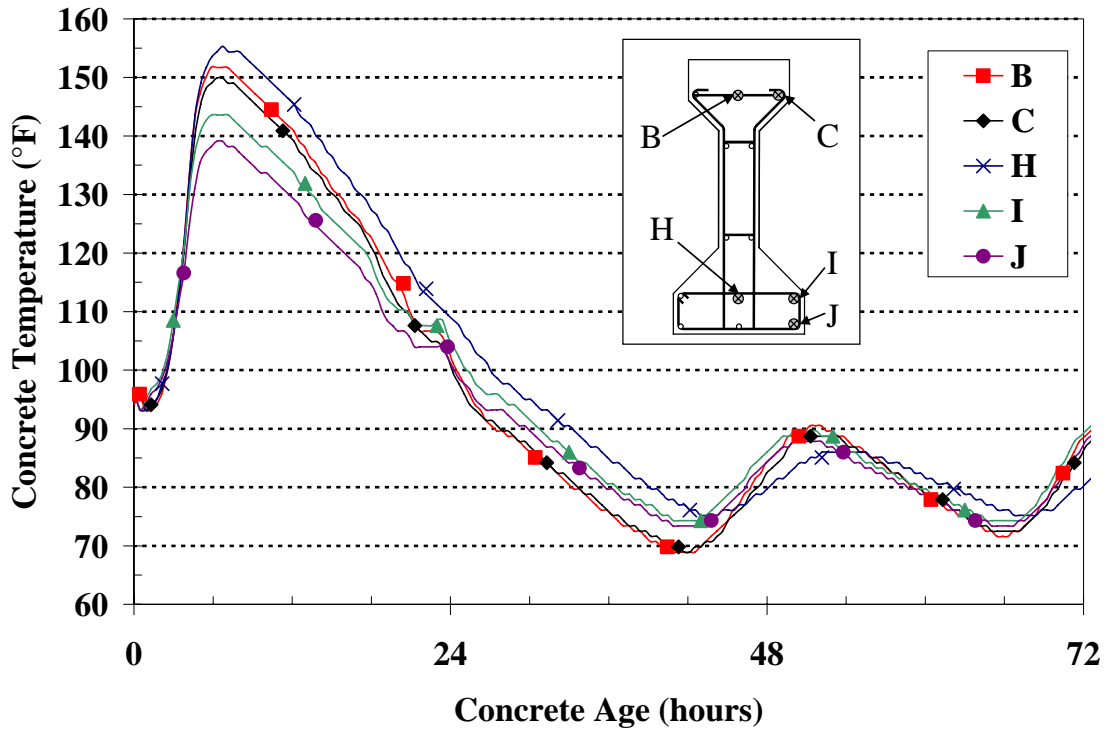

Figure 4-64: Concrete temperature histories of iButton Tree 4

As shown in Figure 4-64, the temperature variation changes the most throughout the cross-section at early ages when most of the heat of hydration is being released. Only the early-age temperature should be considered when selecting the most appropriate location for the temperature sensors. The centers of the bottom and top flanges (Locations B and H) have the highest temperatures, whereas the lowest temperatures occur at the outside of the bottom flange at Locations I and J. Most of the prestressed strands are located in the bottom flange; therefore, the concrete strength is most critical in the bottom flange when the prestressed force is transferred. Under these conditions, a temperature sensor should be placed at the location where the minimum temperature occurs at early ages. This would be on the stirrup close to the surface of the bottom flange. By placing the temperature sensors at the surface of the bottom flange, the sensor will also be out of

the way of all of the prestressed strands, ensuring that the probe does not interfere with the bond of the prestressed strands.

The other consideration is location along the length of girder since temperature varies along the length of the girder. The temperature profile along the length of the girder close to the surface of the top flange (Location C) can be seen in Figure 4-65. The center of the girder has the highest temperature and the ends of the girder have the lowest temperatures, which is to be expected. So again, the maturity temperature sensors should be placed in the ends of the girder on the stirrup close to the surface of the bottom flange. By placing the temperature sensor in that location, the temperature sensor will capture the slowest strength develop since the lowest temperatures are in this region. Also, the temperature sensors will be out of the way of most of the critical sections in the girder. The remainder of the temperature profiles are presented in Appendix B.

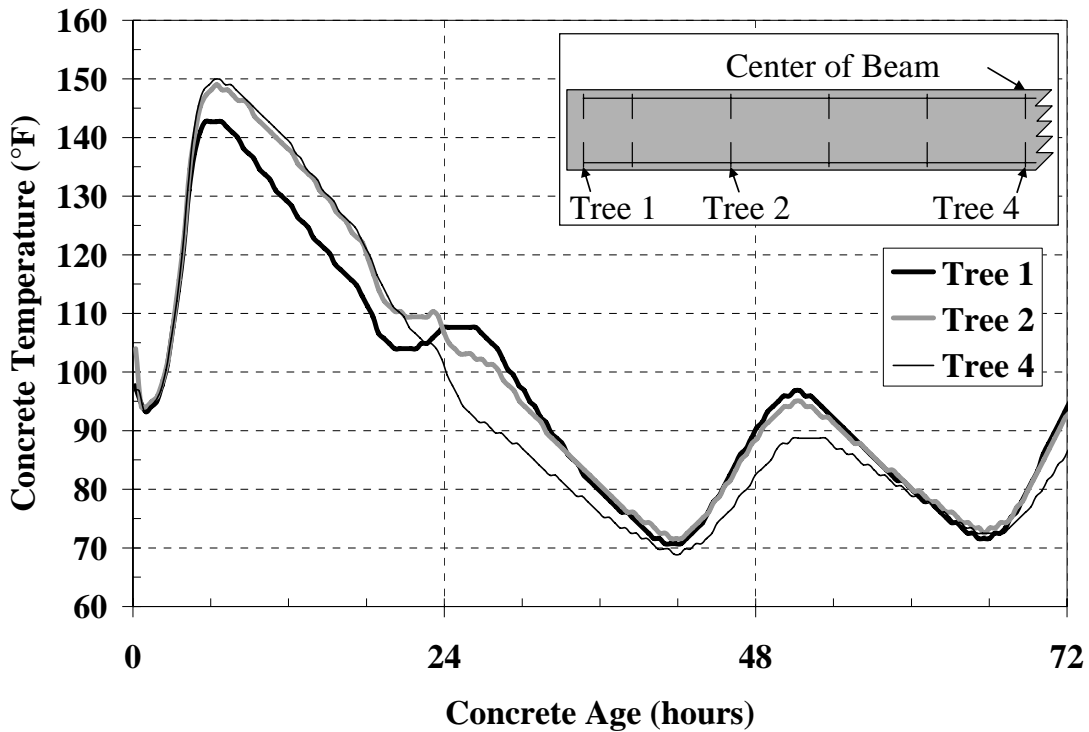

Figure 4-65: Temperature profile along the girder at location C

When placing temperature sensors in a prestressed element, sensors should not be in direct contact with reinforcement. The reinforcement temperature may affect the actual concrete temperature. A material that does not conduct heat can be used to shield the temperature sensor from the reinforcement. The temperature sensor should be secured to stirrups and not to the prestressed strands to ensure that the sensors do not interfere with the bond between the strands and the concrete. It is recommended that the temperature sensor used for the maturity method should be placed in the end of the girder at the outside of the bottom flange where the minimum temperatures were found in this project.

4.6 SUMMARY AND CONCLUSIONS

Overall, the maturity method reflected the concrete strength accurately for the prestressed girder field project. The objectives stated in Section 4.1 were accomplished. The S-M relationships that were developed using cylinders cured in laboratory and field conditions all estimated the concrete strength accurately. Four different maturity methods were evaluated: Nurse-Saul maturity function with datum temperatures of $-10\text{ }^{\circ}\text{C}$ and $0\text{ }^{\circ}\text{C}$, and Arrhenius maturity function with activation energies of 33.5 kJ/mol and 40 kJ/mol . For estimating the strength of the molded cylinders the following conclusion were supported by the test results:

- The Arrhenius maturity function was more accurate than the Nurse-Saul maturity function.
- Both activation energies estimated the molded cylinders' strength accurately, and there was not enough evidence to conclude that one activation energy more accurately estimated the strength than the other.

- The Nurse-Saul maturity function with $T_o = 0\text{ }^\circ\text{C}$ was slightly more accurate at estimating the cylinder strength than $T_o = -10\text{ }^\circ\text{C}$, but not enough evidence was available to definitively conclude which datum temperature gave more accurate results.

In-place testing also indicated that the maturity method would work for prestressed girder project. Strengths measured from the pullout test correlated very well to those estimated by the maturity method showing little error, whereas the core strengths did not correlate as well. Since the pullout test accurately represented the strength of the concrete, the cores strengths' poor correlations was attributed to low test results, also observed by other researchers. The data supports the following conclusions regarding the accuracy of the maturity method for estimating the in-place strengths:

- The Nurse-Saul maturity function with $T_o = 0\text{ }^\circ\text{C}$ was a slightly more accurate estimation of the in-place strength than was the estimation with $T_o = -10\text{ }^\circ\text{C}$.
- The Nurse-Saul maturity function with $T_o = -10\text{ }^\circ\text{C}$ seems to overestimate the in-place strength slightly more than $T_o = 0\text{ }^\circ\text{C}$.
- The Arrhenius maturity function with $E = 33.5\text{ kJ/mol}$ estimated the in-place strengths more accurately than the function with $E = 40\text{ kJ/mol}$.

When comparing the different curing methods used to develop the S-M relationship, strengths for all curing methods were estimated within the acceptable percent error ranges. The following trends and conclusions were found:

- The *field-cured* S-M relationship estimated the in-place strength more accurately than the *laboratory* S-M relationship, although the *laboratory* S-M relationship estimated strengths within 15% of in-place strengths, which was still acceptable.
- In general, the *laboratory* S-M relationship slightly underestimated the strength of the concrete compared to the two *field-cured* S-M relationships.

More research will be conducted to determine if *field-cured* S-M relationships always estimate the strength development of the concrete more accurately than the *laboratory* S-M relationship as required by ASTM C 1074 (2004).

Since both of the field-curing methods are very similar in estimating the S-M relationships, use of the lime-saturated water-tank curing method is recommended, based purely on ease of use. The lime-saturated water-tank curing method was easier to implement because it only involved an aluminum tank and lime-saturated water; the damp-sand-pit was more difficult to implement due to the requirement that the cylinders be dug out of the sand, and that the sand stay damp with water. However, if the damp-sand-pit method is desired, it is considered an acceptable means for developing an accurate S-M relationship.

Finally, evaluations of the testing schedule for the field-cured specimens were made and the following conclusions were drawn:

- Fewer testing ages were necessary to capture the strength development of the concrete that were employed in this study. As long as the initial strength development, the transition area, and the age corresponding to the required

strength are included in the testing ages, that is sufficient to develop the strength-maturity relationship.

- The 28-day testing age will make it possible to evaluate the concrete used to develop the strength-maturity relationship and ensure that the concrete meets the necessary strength requirements.
- The recommended testing ages to create the S-M relationship for a precast prestressed girder operation is 6, 12, and 24 hours, and 3, 7, and 28 days.

The inclusion of strengths corresponding to confidence levels in a prestressed application could be a useful calculation to ensure that the required strength in the concrete is achieved before the prestressed strand force is applied to the concrete. The S-M relationship with a confidence level of 50% and 10% defect level seems to be adequate. Confidence levels inherently require more time to elapse before verification testing can occur, but they do ensure with a high degree of confidence that the strength of the in-place concrete is adequate for the construction processes to continue.

Temperature sensor should be placed in the area of the girder where the minimum temperature of the concrete exists. Use of the minimum temperature history of the concrete girder, ensures that the slowest strength development of the concrete is captured. For this project, the minimum temperature in the girder was found in the ends of the girder near the outside surface of the bottom flange. It is recommended that each prestressed girder producer run similar tests to ensure that the prestressed construction process they are using shows the same trends that were found in this project. Only if

in-place testing is being conducted on the girder should the temperature sensors be placed in another location.

In general, the maturity method estimated the concrete strength for the prestressed construction process accurately. The prestressed construction process is a very structured process that is carried out with a high degree of control; therefore, it is not surprising that the maturity method worked well. The second project, which is a bridge deck application described in Chapter 5, will help answer some questions not totally answered with this field project.

CHAPTER 5
EVALUATION OF THE MATURITY METHOD UNDER BRIDGE DECK
CONSTRUCTION OPERATIONS

The accuracy of the maturity method for use in bridge deck construction applications will be evaluated in this chapter. Actual construction processes used to construct a bridge deck were used for this evaluation. Preparation and strength tests for field testing were conducted at Auburn University, but field testing was conducted at the ALDOT I-85 and US 29 bridge project in Auburn, Alabama with the assistance of Scott Bridge Company from Opelika, Alabama. The field testing portion of this project was conducted from December 2004 to July 2005.

5.1 EXPERIMENTAL DESIGN

Multiple objectives were targeted for the bridge deck field project. The primary objective was to assess the accuracy of the maturity method to estimate the in-place strengths of a bridge deck. The evaluation of the maturity method was conducted under different seasonal weather conditions, and a proposed maturity specification was implemented of the bridge deck construction to assess the efficiency of the specification. Other objectives were to evaluate the cylinder curing condition best suited to simulate the bridge deck curing history and to develop a cylinder testing schedule to define the strength-maturity

relationship. The most appropriate location for the temperature sensors to measure the maturity of the concrete was also determined.

5.1.1 ANALYSIS APPROACH

To evaluate the accuracy of the maturity method for bridge deck construction applications, two separate evaluations were conducted during this field project: (1) assessment of the accuracy of the maturity method to estimate the in-place strength of the concrete and (2) assessment of the accuracy of the use of molded cylinders for verification testing. The first evaluation is similar to the precast prestressed field project; two mock bridge decks were constructed to assess accuracy of the maturity method to estimate the in-place concrete strength. Different cylinder curing conditions were evaluated to determine which curing condition would create a strength-maturity relationship that would accurately estimate the in-place strengths. The second phase was designed to evaluate the accuracy of molded-cylinder verification testing as recommended by ASTM C 1074 Section 9.5.4 and other transportation agencies. The second phase was evaluated using fieldwork that was performed during the construction of the actual bridge deck. A chart outlining the testing for the bridge deck field project is shown in Figure 5-1.

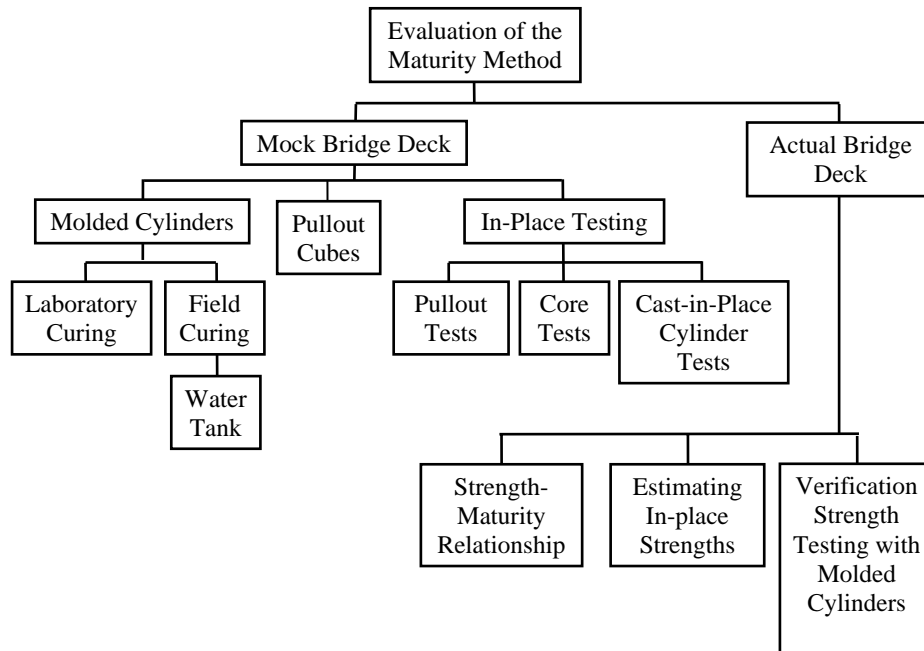

Figure 5-1: Planned research for bridge deck project

5.1.1.2 Mock Bridge Deck Testing Design

The mock bridge deck was designed to evaluate the effects of different curing methods for molded cylinders on the maturity method, to test ability of the maturity method to estimate the in-place strengths, and to evaluate the effects of the seasonal weather variations on the maturity method. A mock deck was built so that in-place testing could be conducted and the actual bridge deck would not be damaged. The mock bridge deck was constructed adjacent to the actual bridge under construction, so that it would be exposed to the same environmental conditions as the actual bridge deck under construction.

This phase of testing was conducted in the winter months and then again in the summer months. For the cold-weather testing, the mock bridge deck was cast in mid-February 2005, and testing performed through mid-March 2005. For the warm-weather

testing, the mock bridge deck was cast in mid-June 2005, and was testing concluded in mid July 2005.

During the mock bridge deck phase, there were two sets of molded cylinders that were cured differently to evaluate which curing condition would more accurately estimate the in-place strength of the bridge deck. As in the precast prestressed girder project, the first curing method was the laboratory curing in accordance with AASHTO T 23 (2004). In this method recommended by ASTM C 1074 (2004), the curing temperature is controlled to be at $73\text{ }^{\circ}\text{F} \pm 3\text{ }^{\circ}\text{F}$. The other curing method evaluated was field-cured specimens, which were designed to mimic the curing temperatures of the bridge deck. For the precast prestressed girder project, two different field-curing methods were conducted: lime-saturated water-tank and damp-sand-pit. Results and conclusion comparing the two curing methods for the precast prestressed girder project can be found in Section 4.6. From the results of the precast prestressed girder project there was very little difference between the two field-curing methods, so therefore only the lime-saturated water-tank was evaluated for the bridge deck project.

The other evaluation that was performed using the mock bridge deck was the accuracy of the maturity method to estimate the in-place strength. As explained in Section 4.1.1.2, the in-place testing was conducted because molded specimens cured under laboratory or field conditions are not always accurate at estimating the in-place strength of the concrete. Three methods were used to determine the in-place strength of the bridge deck: pullout testing, compressive testing of cast-in-place cylinders, and compressive testing of cores.

For the precast prestressed girder project, it was found that the pullout table provided by Germann Instruments to correlate the pullout force measured from the pullout machine to the compressive strength of a 6 x 12 inch cylinder was accurate. However, more tests were conducted in this project to reconfirm the results that were found in the precast prestressed girder project. The same methods using the pullout cubes that were conducted in the precast prestressed project were applied in the bridge deck project. If the compressive strength estimated from the pullout tests performed on the cubes and the compressive strengths measured from the molded cylinders at the same maturity were relatively close, then the pullout table was considered accurate.

After the pullout table was confirmed as accurate, the pullout test was used to assess the in-place strength. For this project, strengths from the three in-place testing methods were compared to the strength estimated from the laboratory-cured and field-cured strength-maturity relationships. The pullout tests were conducted because of the good accuracy of the test that was found in the precast prestressed girder project. In addition, the compressive testing of cores was conducted because this is the preferred method by ALDOT for measuring in-place strength. Since the core results were not found to be accurate during the precast prestressed girder project, compressive testing of cast-in-place concrete cylinders was added to assess the in-place strength.

5.1.1.3 Evaluation of the Use of Molded Cylinders for Verification Testing

The evaluation of the use of molded cylinders for verification testing was designed to assess the methods for verifying the strength estimated by the maturity method for possible ALDOT use in construction projects. During the construction of actual bridge

decks, the strength-maturity relationship will be developed in accordance with ASTM C 1074 and verification tests will be conducted from as-delivered concrete molded into cylinders. The other objective of this phase is to evaluate the optimum location for temperature sensor installation in the bridge deck.

5.1.1.4 Maturity Functions and Strength-Maturity Relationship Evaluations

For evaluating the maturity method for the bridge deck construction application, the same maturity functions that were evaluated in the precast prestressed field project were used for this field project. The strength and temperature data obtained from the different cylinder curing methods for the mock bridge deck and the evaluation of the use of molded cylinder for verification testing were used to create different strength-maturity curves as explained in ASTM C 1074 (2004). The Nurse-Saul maturity function with datum temperature of 0 °C and -10 °C (32 °F and 14 °F) were evaluated along with the Arrhenius maturity function with activation energy values of 33,500 and 40,000 J/mol. The reasons why these functions and corresponding values were evaluated are explained in Section 4.1.1.1. Equations showing how to calculate the two maturity functions are presented in Section 2.2.

Confidence levels applied to the strength-maturity relationship for the bridge deck construction were also considered. For the I-85 and US 29 bridge deck project, a defect level of 10% was used to estimate strengths at various confidence levels. Confidence levels equal to 50%, 75%, and 90% were considered which were the same as for the precast prestressed project. These confidence levels were applied to the strength-maturity relationship from the mock bridge deck to evaluate the effectiveness of the confidence

levels to estimate strengths determined from molded cylinders and in-place testing methods. Confidence levels were applied to the strength-maturity relationship to evaluate whether they should be used when verifying the strength of the concrete.

5.1.2 MOCK BRIDGE DECK TESTING LAYOUT

The following section explains the tests that were conducted for the mock bridge deck. Actual test procedures are explained in Section 5.3.

5.1.2.1 Assessment of the Curing Conditions for the Molded Cylinders

Laboratory-cured and field-cured specimens were used for this project. Testing ages for these two curing methods were taken from ASTM C 1074 (2004): 1, 3, 7, 14, and 28 days. In addition, the testing age of 2 days was added to the testing schedule to help gather more early-age test results. Therefore, the final testing schedule was 1, 2, 3, 7, 14, and 28 days. ASTM C 1074 (2004) only recommends to conduct more early-age tests when concrete with rapid strength development is used; therefore, the testing schedule above was the same for the cold-weather placement and the warm-weather placement of the mock bridge deck.

One other set of tests that was conducted in the mock bridge deck evaluation was compressive testing of 4 x 8 inch molded cylinders. This was conducted to eliminate any problems that could occur with the strength results due to the size difference between 6 x 12 inch cylinders and 4 x 8 inch cylinders. Since the cores and cast-in-place cylinders were 4 x 8 inch cylinders, 4 x 8 inch molded cylinders were cast during the construction of the mock bridge deck.

5.1.2.2 Design of Mock Bridge Deck

Two factors were considered when designing the mock bridge deck: (1) making the bridge deck large enough to conduct the in-place testing without any of the tests interfering with one another and (2) molding the actual bridge deck as accurately as possible. Multiple tests had to be conducted on the mock bridge deck to establish the in-place strength of the concrete, such as temperature recording, pullout testing, cast-in-place cylinders, and coring. Each test had to be carefully located. Based on these considerations and the structural design of the mock bridge deck, the final size was 5 feet 6 inches by 10 feet 6 inches by 9½ inches thick.

First, the locations of all the tests were selected. The same procedures for the cores that were used for the precast prestressed project were repeated for the mock bridge deck phase. The cores were four-inch diameter cores and had a length-to-diameter (L/D) ratio equal to 2.0. This then required the slab to be a minimum of at least nine inches so that the tops and bottoms of the cores could be trimmed off. Compared to the actual bridge deck, which is normally about 6 to 7 inches, the mock bridge deck was thicker. The testing ages were 7 and 28 days, and the curing methods of ASTM C 42 (2004) and AASHTO T 24 (2002) were used to condition the cores after they were extracted from the mock deck. Clear spacing between the cores was to be a minimum of four inches, which was the diameter of the cores. Twelve cores were removed at each age; two of these cores were used for temperature recording, and the other ten were tested to determine their compressive strength. Five cores were used for each for the two curing methods. A total of twenty-four cores were removed from the mock bridge deck. The location of the cores can be seen in Figure 5-2.

For the cast-in-place (CIP) cylinders, the same diameters and lengths that were used for the cores were used for the CIP cylinders. This was ideal because 4 x 8 inch plastic molds were to cast the cylinders in the structure. Later in Section 5.3, the actual procedures used to make the CIP cylinder are explained. Due to the aluminum sleeve in which each 4 x 8 inch plastic mold and a 1½ inch wood block were placed inside, the depth of the slab had to be 9½ inches. At each testing age, four CIP cylinders were removed with a temperature sensor installed in one of them. The other three CIP cylinders were tested to determine their compressive strength. The testing ages that were used for the CIP cylinders were 1, 2, 7, and 28 days. Sixteen CIP cylinders were installed in the mock bridge deck. The location of the CIP cylinders can be seen in Figure 5-2.

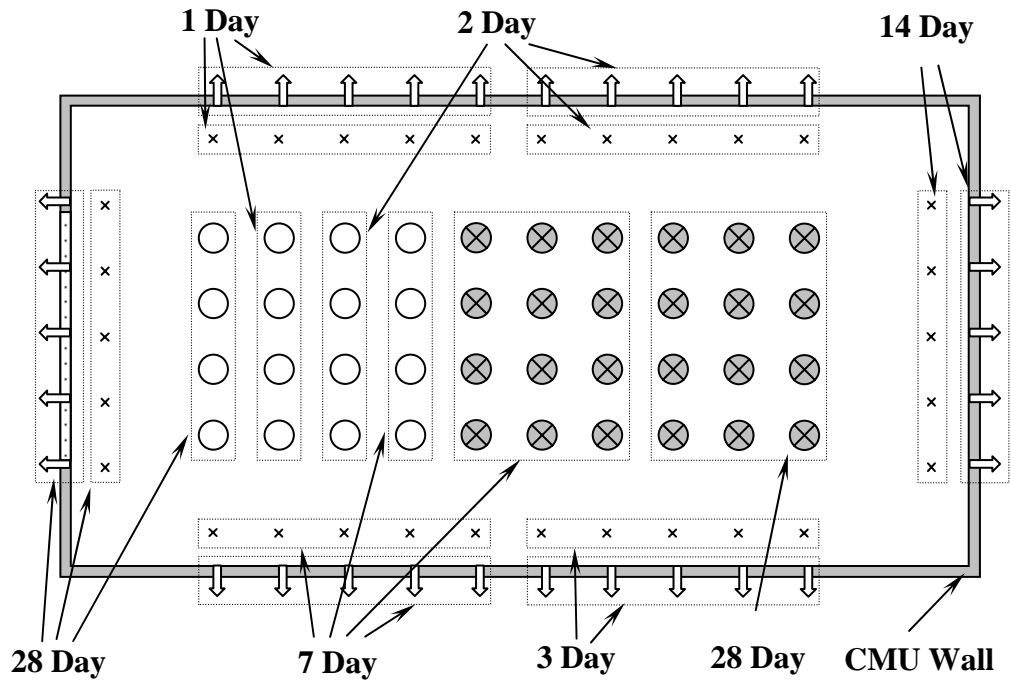

Top Layout

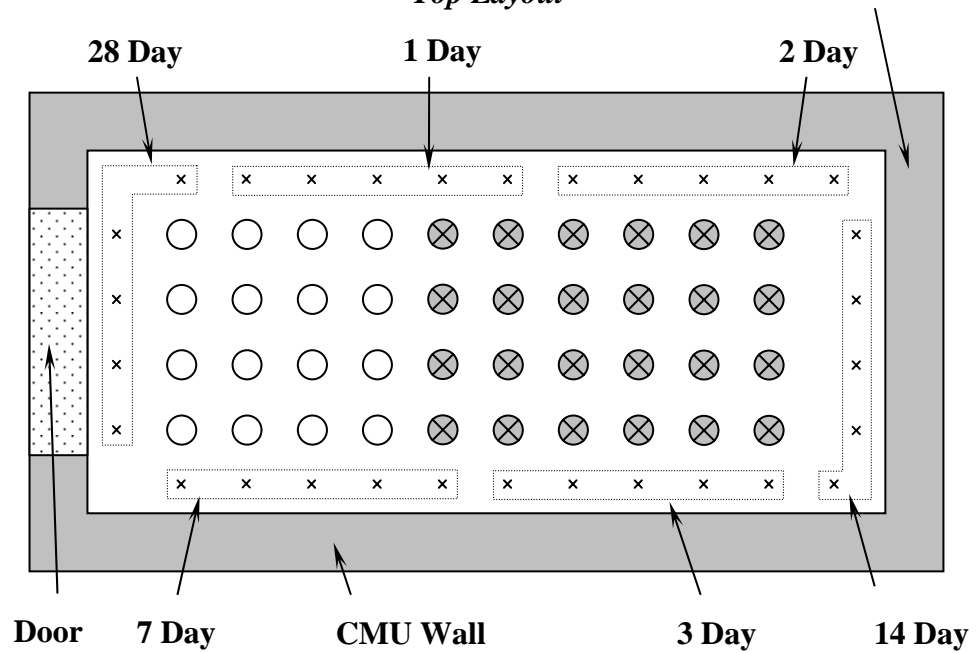

Bottom Layout

⇓	Side Pullout Inserts	○	Cast-In-Place Cylinders
×	Top & Bottom Pullout Inserts	⊗	Cores

Figure 5-2: In-place testing layout for the mock bridge deck

For the pullout test, the inserts were installed and tested on the top, side, and bottom of the mock bridge deck. The spacing requirements of ASTM C 900 (2004) were all satisfied. The requirement for the spacing of the inserts from the edge of concrete required the depth of the slab to be a minimum of nine inches for the side pullout inserts. For the top, side, and bottom five inserts were tested at each age; this is the minimum required by ASTM C 900 (2004). The pullout testing ages corresponded with the field-cured cylinder schedule, which was 1, 2, 3, 7, 14, and 28 days. Ninety pullout inserts were installed in the mock bridge deck. The layout of the pullout inserts can be seen in Figure 5-2.

Once the layout of the in-place testing was complete, the structural performance of the mock bridge deck was considered in the design. Live loads would be applied to the mock bridge deck due to testing that would occur and these were considered in the structural design calculations. In addition, it was taken into consideration that the elevated slab would have many holes due to coring and removal of the cast-in-place cylinders, which would lower the structural capacity of the mock bridge deck. With these factors, the amount of reinforcement needed to support the slab was calculated and by shifting the in-place test location slightly, the reinforcement was placed in the mock bridge deck so that the steel would not interfere with any of the in-place testing. The final reinforcement design can be seen in Figure 5-3.

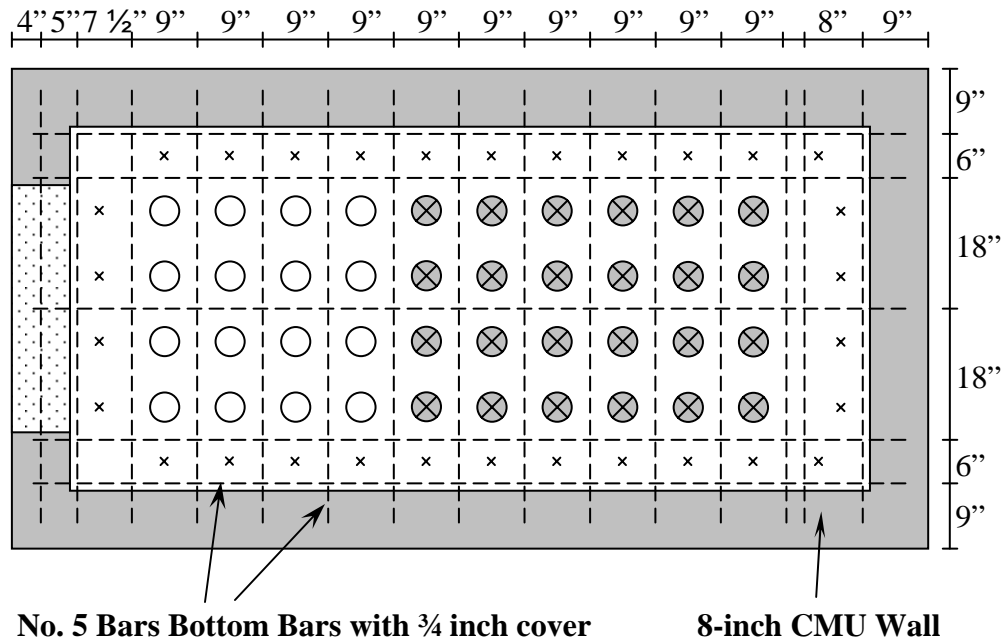

Figure 5-3: Steel reinforcement layout of the mock bridge deck

The temperature sensors layout for the mock bridge deck was designed to collect the maturity of the in-place tests as accurately as possible. The iButtons were attached to multiple steel brackets throughout the mock bridge deck. On each bracket three iButtons were installed, one at the top, middle, and bottom of the slab. Eighteen iButtons were installed; the location of all the iButtons can be seen in Figure 5-4.

Location 1 was used to calculate the maturity for the 28-day pullout test. For the 1 and 2 day pullout tests, Location 2 was used; for the 3- and 7-day tests, Location 4 was used. Finally, Location 3 was used for the 14-day pullout test. Since three iButtons were installed on the steel bracket at each location, the top iButton was used for the top pullout inserts, the middle iButton was used for the side inserts, and the bottom iButton was used for the bottom inserts. The temperature history of the cores before they were removed from the mock bridge deck was obtained from the middle iButton at Location 5 and 6.

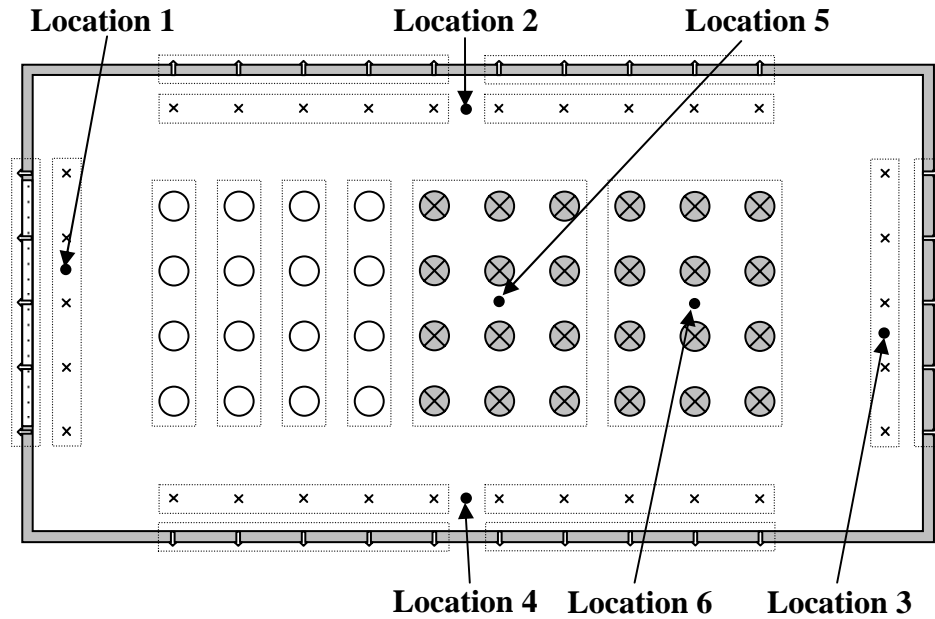

Figure 5-4: Plan view of iButton locations for the mock bridge deck

In order to mimic the actual bridge deck, a structure was built to elevate the mock bridge deck so that the ambient temperatures could be felt underneath the deck. A reinforcement concrete pad was cast on the ground. Then concrete-masonry-unit (CMU) walls were built to support the deck. The bottom of the mock bridge deck was approximately 6 feet 4 inches above the ground. Forms with props were used to support the fresh concrete weight until the slab was sufficiently strong enough to support its own weight. The structure can be seen in Figure 5-5.



Figure 5-5: Mock bridge deck structure

5.1.2.3 Verification of the Pullout Table

More pullout verification tests to confirm the accuracy of the pullout table were conducted. The same process used for the precast prestressed girder project of using cubes (8 x 8 x 8 inch) to verify the correlation between the pullout force and compressive strength was used. Additional 6 x 12 inch cylinders cured like the cubes were used to determine the compressive strength. The testing ages for the pullout cubes were 1, 2, and 7 days. A total of six cubes were cast, and two cubes (eight inserts) tested at each age.

5.1.3 ACTUAL BRIDGE DECK TESTING LAYOUT

The actual bridge deck testing of this project was designed to evaluate the ASTM C 1074 (2004) recommendation in Section 9.5.4 for using molded cylinders to verify the strength estimated by the maturity method. This was evaluated on two bridges that were constructed at the I-85 and US 29 construction site. The bridges were built in two phases, the southbound lanes were built first and then the northbound lanes were built after the existing bridge was removed. The first deck tested was the southbound lanes of US 29 that crossed over I-85, and the second deck was the southbound lanes of US 29 that crossed over the Parkerson Mill Creek. For the rest of the thesis, the bridge crossing I-85 will be referred to as the “I-85 Bridge” and the bridge crossing Parkerson Mill Creek will be referred to as the “Creek Bridge”.

The I-85 Bridge deck was cast in three sections on December 21, 2004; January 5, 2005; and January 10, 2005. Temperatures sensors were placed in each segment but verification tests were only conducted on the first two segment. For the Creek bridge deck, only one placement was used for the entire deck on March 4, 2005, and verification testing was conducted for the entire bridge.

Temperature sensors were installed throughout the bridge decks to capture the temperature history of the concrete. The main objective was to evaluate the ideal location for the maturity to be recorded. Therefore, many iButtons were installed in the bridge decks. For the I-85 Bridge the temperature sensors were installed in 16 locations. At each location three iButtons were installed to measure the temperature profile through the depth of the bridge deck. An illustration of the three iButtons at each location can be seen

in Figure 5-6. The layout of the iButton locations for the I-85 Bridge is shown in Figure 5-7.

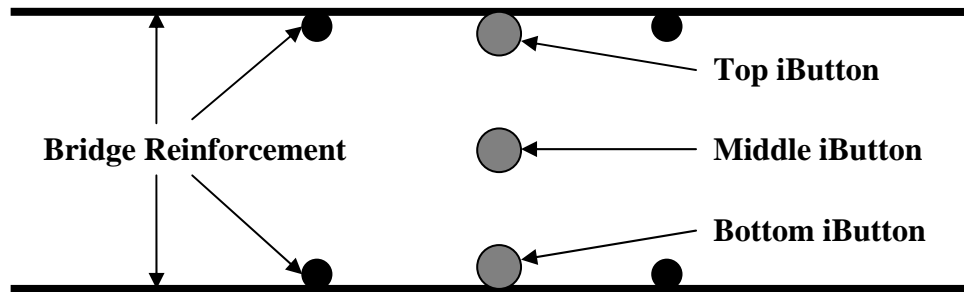

Figure 5-6: Diagram of the iButtons at each location

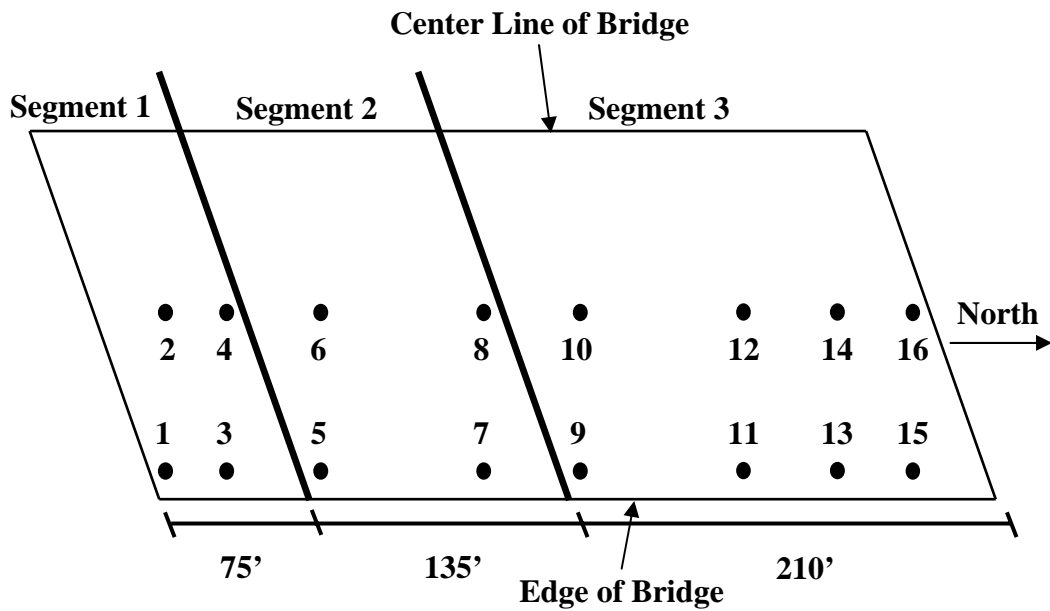

Figure 5-7: Temperature sensor layout for the I-85 Bridge

For the Creek Bridge, there were six locations where the temperature sensors were installed; at each location three iButtons were installed to measure the temperature history. The layout of the iButton locations for the Creek Bridge can be seen in Figure 5-8.

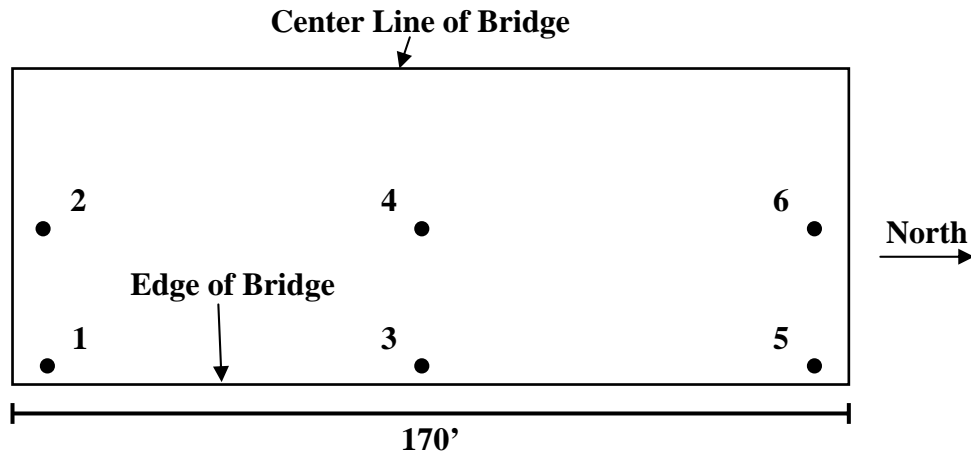

Figure 5-8: Temperature sensors layout for the Creek bridge

The strength-maturity relationship was developed from concrete that was placed at Location 8 for the I-85 Bridge and Location 5 for the Creek Bridge. Verification tests were conducted at Locations 2, 4, and 5 for the I-85 Bridge and at Locations 1 and 3 for the Creek Bridge. Two testing ages were conducted for the verification tests: (1) when the verification cylinders reached the maturity that corresponded to 2,400-psi and (2) an actual age of 7 days. The 2,400-psi strength requirement was used because this is the strength that ALDOT requires for most construction operations to continue (ALDOT 2002). The 7-day verification test was to verify that the concrete placed in the structure was following the strength-maturity relationship developed.

5.2 MATERIALS AND PROPERTIES

The concrete mixture design was the ALDOT-specified mixture design AL-AF1C (ALDOT 2002). The concrete producer for the bridge construction supplied the concrete. The same mixture design was used for all phases of this project. Table 5-1 contains the mixture proportions for one cubic yard of the concrete and the specified fresh and hardened concrete properties. All coarse and fine aggregate weights are given in terms of the saturated, surface-dry condition.

Table 5-1: Bridge deck concrete mixture proportions

Item	Mixture Design
Water (pcy)	275
Type I Cement (pcy)	434
Class C Fly Ash (pcy)	186
Coarse aggregate (pcy)	1,879
Fine aggregate (pcy)	1,089
Air-Entraining Admixture* (oz/yd)	2.0
Water-Reducing Admixture ⁺ (oz/yd)	20.0
Target air (%)	5 (± 1)
Target slump (in.)	< 3.5
w/c	0.44
f _c (psi)	4,000

* Degussa Inc., MBAE 90

⁺ Degussa, Inc., Pozzoloth 122-R

The Type I cement was obtained from Cemex and was produced at the plant in Clinchfield, GA. The mineral admixture was a Class C Fly Ash obtained from Holcim and was produced at the plant in Quinton, AL. The coarse aggregate was No. 67 river gravel from Martin Marietta in Shorter, AL. The fine aggregate was obtained from Coach

Sand located in Cypress, AL. Specific gravities for the materials are in given Table 5-2, but gradations of the coarse and fine aggregate were not obtained.

Table 5-2: Material properties for bridge deck

Materials Description	Specific Gravity	Absorption (%)
Water	1.00	-
Type I Cement	3.15	-
Coarse aggregate	2.62	0.3
Fine aggregate	2.64	0.1

5.3 FIELD PROCEDURES AND TESTING FOR MOCK BRIDGE DECK

This section documents all of the procedures that were used for the bridge deck field tests. The same testing procedures that were used on the prestressed project were used for the mock bridge deck to ensure consistent data between the two field projects. The mock bridge deck was constructed twice: a cold and warm-weather placement. For both decks, the same testing procedures were used.

5.3.1 FRESH CONCRETE TESTING

Fresh concrete properties were taken to ensure that the concrete that was supplied for the research met ALDOT specifications. All fresh concrete tests were conducted or overseen by an ACI Concrete Field Testing Technician – Grade I.

5.3.1.1 Quality Control Testing

The quality control tests that were conducted on the mock bridge deck were slump, air content, and fresh concrete temperature. All fresh concrete properties were tested in

accordance to AASHTO Specifications: slump - AASHTO T 119 (2005), air content - AASHTO T 152 (2005), and fresh concrete temperature - AASHTO T 309 (2005).

5.3.1.2 Making and Curing Specimens

The laboratory-cured 6 x 12 inch cylinders, lime-saturated water-tank 6 x 12 inch cylinders, 4 x 8 inch cylinders, and pullout cubes were all cast from concrete that was taken out of the middle of the concrete truck as specified in AASHTO T 141 (2005). All specimens were cast with the same concrete that was placed in the mock bridge deck and then moved to different curing conditions at the appropriate times. The specimens were cast on a hard surface to ensure that good quality specimens were produced, as shown in Figure 5-9.



Figure 5-9: Casting of concrete specimens

For the laboratory-cured and field-cured cylinders, a total of 38 - 6 x 12 inch white plastic cylinder molds were used. All cylinders were made in accordance with AASHTO T 23 (2004). Once the specimens were made and the plastic lids snapped on,

19 of the cylinders were used for the laboratory curing conditions which were the same as for the precast prestressed girder project (Section 4.3.1.2). At each age, three cylinders were tested, and one cylinder was instrumented with a temperature sensor to measure the concrete's temperature history. The testing ages for the laboratory-cured cylinders were 1, 2, 3, 7, 14, and 28 days.

The remaining 19 - 6 x 12 inch cylinders were cured in the field in a lime-saturated water-tank. All of the cylinders were placed below the mock bridge deck for the first 24 hours, after which the cylinders were removed from the plastic molds and placed in the lime-saturated water-tank. The water-tank was placed next to the mock bridge deck and was exposed to ambient temperatures for a couple of days before the testing was conducted to ensure that the temperature of the water was close to the ambient temperature. The testing ages for the field-cured cylinders were 1, 2, 3, 7, 14, and 28 days.

Along with the 6 x 12 inch molded cylinders, 13 - 4 x 8 inch molded cylinders were made. All cylinders were made in accordance to AASHTO T 23 (2004). After the cylinders were made, plastic lids were snapped on, and the same curing procedures that were used for the 6 x 12 inch field-cured specimens were used. The testing ages for the field-cured cylinders were 1, 2, 7, and 28 days.

The final set of specimens that were made was the pullout cubes. The same testing procedures and molds that were used in the precast prestressed girder project were used for these cubes. Details of how the molds were made and the testing procedures for making the cubes are presented in Section 4.3.1.2. The mold was filled in three layers, each layer was rodded 56 times, and the sides were tapped with a mallet 16 times. After

the cubes were cast, the molds were placed in double bags and sealed to prevent any moisture loss from the concrete. The cubes were then cured under the mock bridge deck and moved to the lime-saturated water bath after 24 hours. Six cubes were made with four inserts in each cube and eight pullout tests were performed at ages of 1, 2, and 7 days.

5.3.2 HARDENED CONCRETE TESTING

After the concrete set, hardened concrete testing was performed to assess the strength characteristics of the concrete. Compression tests and pullout tests were conducted on the molded specimens. The pullout tests, compressive testing of cast-in-place cylinders and compressive testing of cores were performed on the mock girder as explained in Section 5.3.4. The maturity of each specimen was calculated from its measured temperature history. All hardened concrete tests were performed by ACI Certified Concrete Strength Testing Technicians.

5.3.2.1 Compression Testing

Compression tests were performed in accordance with AASHTO T 22 (2005). All specimens were tested at Auburn University. Compression testing was conducted on 6 x 12 inch and 4 x 8 inch cylinders cured under laboratory and field conditions.

Neoprene pads were used for all compression tests. Fifty-durometer neoprene pads were used for 1, 2, and 3 day testing ages for the laboratory and field cured specimens. For all other testing ages, 60 durometer neoprene pads were used. The compressive strength rating for a 50 durometer pad is 1,500 to 6,000 psi, and the rating

for 60 durometer pads is 2,500 to 7,000 psi. The load rate required by AASHTO T 22 (2005) for a six-inch diameter concrete cylinder ranges from 34,000 to 85,000 lbs per minute; therefore, a consistent load rate of 60,000 lbs per minute was used. For the 4 x 8 inch cylinders, the load rate range required by AASHTO T 22 (2005) is between 15,000 to 37,000 lbs per minute. A consistent load rate of 26,000 lbs per minute was used for these cylinders.

5.3.2.2 Pullout Tests Performed on the Molded Cubes

All pullout tests conducted on the molded cubes were done in accordance with ASTM C 900 (2001). Inserts that were installed in the cubes were LOK-TEST inserts L-46, which are design for pullout loads between 0 and 100 kN. The load rate that was used for the pullout test was 0.5 ± 0.2 kN/sec (112 ± 45 lbf/sec), which is the recommend load rate for the inserts by ASTM C 900 (2001).

5.3.3 TEMPERATURE RECORDING EQUIPMENT

The iButton by Dallas Semiconductor (Maxim) was used for the temperature recording for this project. This was the same temperature-recording device that was used for precast prestressed girder project explained in Section 4.3.3.

5.3.3.1 Temperature Recording for Cylinders and Pullout Cubes

The temperature recording for the cylinders and pullout cubes were done the same way as explained for the precast prestressed girder project in Section 4.3.3.2. The time interval programmed in the iButton for the 6 x 12 inch and 4 x 8 inch cylinders was 25 minutes,

and this allowed the iButton to record temperature for over 30 days. For the pullout cubes the time interval was 15 minutes, which allowed the iButton to record data for more than 14 days. An extra cylinder was made for each set of cylinders so that an iButton could be installed to record their temperature history. Strength testing was not conducted on any cylinder with an iButton. One iButton was installed in the center of the 7-day pullout cube, so that the iButton would not affect the pullout results.

5.3.3.2 Temperature Recording for Mock Bridge Deck

The temperature sensors used for the mock bridge deck were the same as the sensors using in the cylinders. Each location where the temperature was recorded had a four-foot wire attached so that the wire would run outside the forms. Each iButton was attached to a bracket so that the iButton would remain in its intended location after the concrete was placed. A picture of iButtons installed in the mock bridge deck and the wire coming out of the concrete can be seen in Figure 5-10. The end of each wire that was outside the structure was labeled to identified the location of the iButton after the concrete was placed. The time interval for the iButtons in the mock bridge deck was 25 minutes which allowed recording of the temperature history for 30 days.

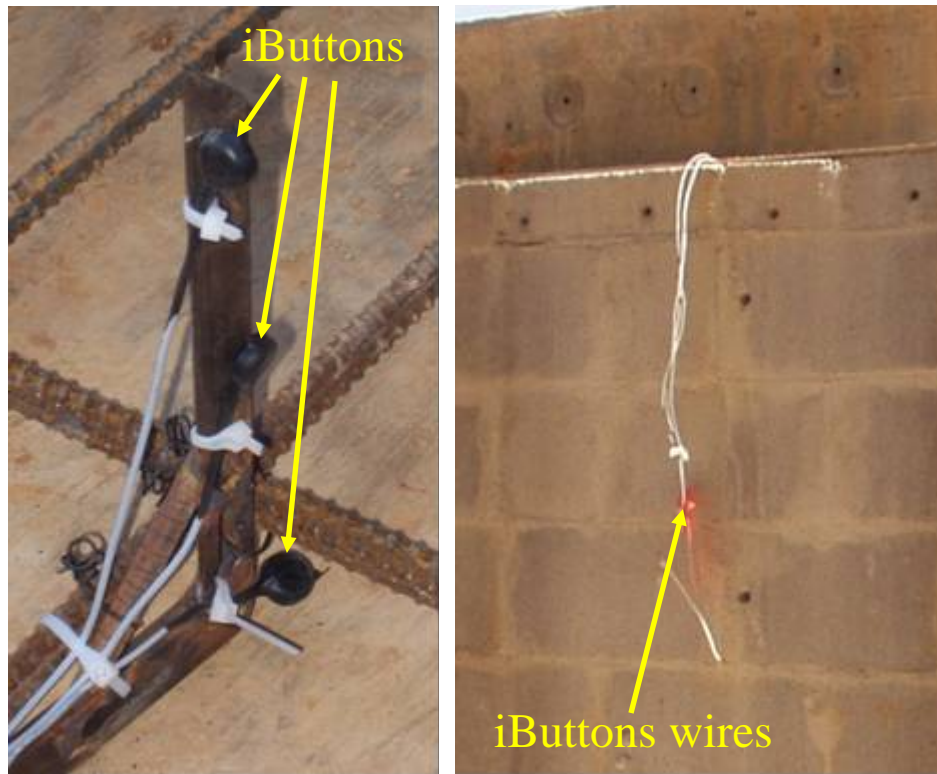

Figure 5-10: iButtons installed in the mock bridge deck

5.3.3.3 Temperature Recording for the Cast-In-Place Cylinders

The iButtons for the cast-in-place (CIP) cylinders were placed the same way as the iButtons for the molded cylinder. After the concrete was cast and finished for the mock bridge deck, an iButton was placed into one CIP cylinder for each testing age. A total of four CIP cylinders had an iButton installed. When the cast-in-place cylinders were tested, one CIP cylinder with an iButton was removed at each age, and that cylinder remained with the other CIP cylinders that were strength tested. The cylinder with an iButton was not strength tested. The time interval for the CIP cylinder iButtons was 25 minutes. A picture of the iButton installed after the concrete was finished can be seen in Figure 5-11.



Figure 5-11: iButtons embedded in the cast-in-place cylinders

5.3.3.4 Temperature Recording for Cores

Temperature recording for the cores was done the same way explained in Section 4.3.3.4 for the precast prestressed girder project. The temperature history until the cores were removed came from the sensor installed in the mock bridge deck. After the cores were removed, a sensor was installed into a core by drilling a hole into the core, and an iButton was secured to the center of the core with rapid-setting cement. The cores with iButtons were not tested for strength.

5.3.3.5 Air Temperature Data

Ambient temperature data were required for the period over which both cold-weather and warm-weather placements were conducted. The climate data were retrieved from the

National Oceanic and Atmospheric Administration website for Auburn/Opelika Airport which is approximately six miles from the construction site.

5.3.4 IN-PLACE TESTING

Three different in-place tests were conducted to assess the accuracy of the maturity method to estimate the in-place strength: pullout tests, compressive testing of cast-in-place cylinders, and compressive testing of cores. All tests were carried out in accordance with AASHTO and ASTM specifications.

5.3.4.1 Pullout Testing

Pullout tests were conducted on the top, sides, and bottom of the mock bridge deck at ages of 1, 2, 3, 7, 14, and 28 days. All pullout tests were conducted in accordance with ASTM C 900 (2001) and the recommendations supplied by the manufacturer of the pullout machine. A load rate of 0.5 ± 0.2 kN/sec (112 ± 45 lbf/sec) was used for all pullout tests. Locations of all the tests are defined in Section 5.1.2.2.

The top inserts were the same inserts used in the precast prestressed girder project for the top. LOK-TEST inserts L-50 (floating inserts) were used. These inserts are designed for pullout loads between 0 and 100 kN, which allow a compressive strength range of 0 to 11,000 psi to be tested. The floating inserts were spaced at 9 inches on center, which meets the ASTM C 900 spacing requirement between inserts of no less than eight times the diameter of the disc. In addition, the spacing for inserts near the edge of the deck was satisfied with the center of the insert at least $4 \frac{1}{2}$ inches from the edge of the mock bridge deck. The installation method used for the top inserts was the same as

for the precast prestressed girder project, which was explained in Section 4.3.4.1. The floating inserts installed on the top of the mock bridge deck are shown in Figure 5-12.



Figure 5-12: Top pullout inserts for the mock bridge deck

The side inserts were LOK-TEST inserts L-41. These are designed for pullout loads between 0 and 100 kN, which allow a compression strength range of 0 to 11,000 psi to be tested. These inserts had a cardboard backing so that the inserts could be nailed to the wooden forms. All ASTM C 900 (2001) spacing requirements were met, and the inserts were positioned so that the reinforcement would not interfere with the pullout failure plane. No extra steps were taken to consolidate the concrete around the side and bottom inserts. The side and bottom inserts can be seen in Figure 5-13, and Figure 5-14 shows the reinforcement and inserts.



Figure 5-13: Side and bottom pullout inserts



Figure 5-14: Reinforcement and pullout inserts

Access panels were cut in the side and bottom of the forms so that pullout testing on the mock deck could be conducted at 1, 2, and 3 days, before the forms were removed at 6 days. The access panels for the side and bottom inserts are shown in Figure 5-15. The

access panels were caulked so that the concrete would not leak from the forms during construction.

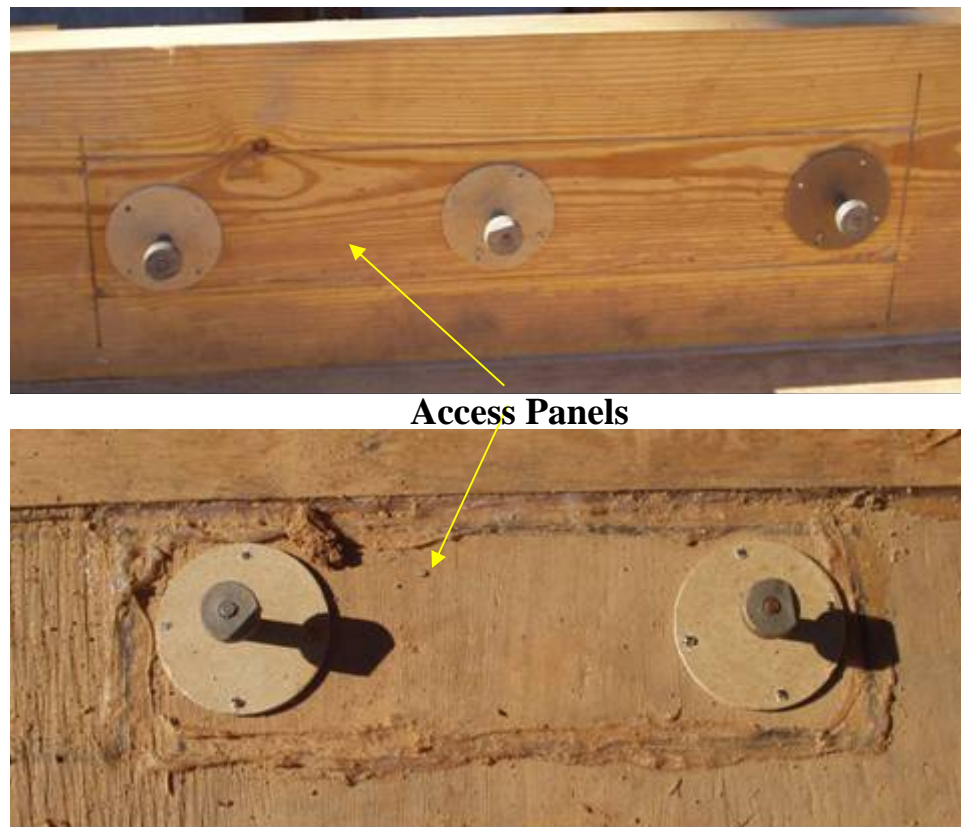

Figure 5-15: Side and bottom access panels

5.3.4.2 Compressive Strength of Cores

The cores were removed, prepared, cured, and tested the same way as the cores used during the precast prestressed girder project. Both ASTM C 42 (2004) and AASHTO T 24 (2002) conditioning methods for the cores were used. The actual testing procedures that were used to extract, condition, and test the cores are explained in Section 4.3.4.2. All cores of the same testing age were removed at the same time to try to eliminate any discrepancy that could occur with differences in curing temperature from removal to

testing. The testing ages for the cores were 7 and 28 days. For the warm-weather placement, the cores for the 7-day testing age were removed at 48 hours. Since cold-weather placement would slow down the strength development of the mock bridge deck, an equivalent age for the 7-day cores was calculated for the cold-weather placement and was determined to be 10 days. Therefore, the first set of cold-weather cores were removed at 5 days and tested 10 days. For both the cold and warm-weather placements, the 28-day cores were removed at 21 days.

The same core diameter, length-to-diameter (L/D) ratio, coring machine, cutting process, curing methods, sulfur capping, and testing explained in Section 4.3.4.2 for the precast prestressed girder project were used for the cores extracted from the mock bridge deck. The cores were cut to obtain an L/D of 2.0, and the inside diameter of the core barrel was 4 inch. The final dimension of the cores after cutting was 4 x 8 inch. The cores were sulfur capped the day before compression testing in accordance with AASHTO T 231 (2005), and strength testing was done in accordance with AASHTO T 22 (2005). A load rate of 26,000 lbs per minute was used.

5.3.4.3 Compressive Testing of Cast-In-Place Cylinders

Sixteen cast-in-place cylinders were installed into each mock bridge deck. ASTM C 873 (2004) was used in testing the cast-in-place cylinders. The cast-in-place cylinder sleeves were not made the way ASTM C 873 recommends; another method was developed that met all the size and durability requirements of ASTM C 873 for the sleeves installed in the concrete. Aluminum was used for the rigid sleeves embedded in the concrete. The aluminum sleeves were 9½ inches tall, which was the depth of the slab. The inner

diameter of the aluminum sleeve was about 4¼ inches and the plastic 4 x 8 inch molds fit snugly inside. A 1½-inch thick wooden plug was placed inside the bottom of the aluminum mold so that the top of the plastic 4 x 8 inch cylinder mold would be at the surface of the concrete. The aluminum molds were nailed to the wooden form by three aluminum tabs that were attached to the sides of the molds. After the aluminum sleeves were installed, the wooden plug and plastic 4 x 8 inch cylinder molds were placed inside the aluminum sleeves. The cast-in-place cylinders can be seen in Figure 5-16.



Figure 5-16: Cast-in-place cylinders installed in the mock bridge deck

When the concrete was placed in the mock bridge deck, the cast-in-place cylinders were filled with concrete. The recommendations from ASTM C 873 (2004) were followed when consolidating the cast-in-place cylinders. The concrete vibrator used to consolidate the mock bridge deck was brought in contact with the outside of each aluminum mold for a couple of seconds and then removed. The vibrator was never placed

inside the cast-in-place cylinder. The same finishing and curing methods used on the mock bridge deck were used for the cast-in-place cylinders. The cast-in-place cylinders can be seen in Figure 5-17 after the concrete has been finished.

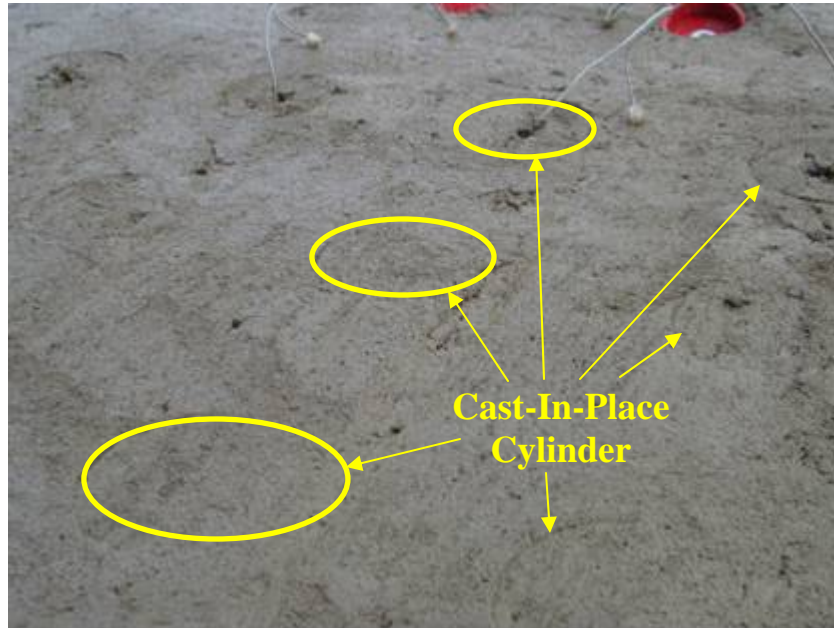

Figure 5-17: Cast-in-place cylinder after concrete was placed

When it was time for testing the cast-in-place cylinders, a 10-ton jack was used to push each cylinder from the bottom out of the concrete. The testing ages were 1, 2, 7, and 28 days. Like the pullout test, access panels were cut in the forms so that the 1 and 2 day cast-in-place cylinders could be removed. A cast-in-place cylinder being removed from the concrete with the jack can be seen in Figure 5-18.



Figure 5-18: Removal of the cast-in-place cylinders

After the cast-in-place cylinders were removed they were transported back to Auburn University testing facilities, stripped from their molds, and compression tested in accordance with AASHTO T 22 (2005). Neoprene pads were used for all compression tests. Fifty durometer neoprene pads were used for 1- and 2-day testing ages, and 60 durometer neoprene pads were used for the 7- and 28-day testing ages. To stay consistent with the 4 x 8 inch cylinder and cores, a load rate of 26,000 lbs per minute was used.

5.4 PROCEDURES FOR THE EVALUATION OF THE USE OF MOLDED CYLINDERS FOR STRENGTH VERIFICATION TESTING

The testing associated with this phase was conducted on the actual bridge decks being cast for the I-85 Bridge and Creek Bridge. Molded cylinders were created from concrete being placed in the bridge deck, and these were used for verification of the strength estimated by the maturity method as recommended in Section 9.5.4 of ASTM C 1074 (2004).

5.4.1 QUALITY CONTROL TESTING

Fresh concrete properties were recorded to ensure that the concrete that was supplied met ALDOT specifications. Each time concrete cylinders were made to create either the strength-maturity relationship or to serve as verification tests, the fresh concrete properties were measured. The quality control tests that were done on the bridge deck were slump, air content, and fresh concrete temperature. All fresh concrete properties were tested in accordance to AASHTO Specifications: slump - AASHTO T 119 (2005), air content - AASHTO T 152 (2005), and fresh concrete temperature - AASHTO T 309 (2005). All testing for fresh concrete tests were conducted by the ALDOT concrete technicians that were there to monitor the placement of the concrete.

5.4.2 HARDENED CONCRETE

After the concrete had set, hardened concrete tests were performed the same way as explained in Section 5.3.2. The maturities of all the specimens were also calculated from their measured temperature history. All hardened concrete tests were performed by ACI

Certified Concrete Strength Testing Technicians. Compression tests were performed in accordance with AASHTO T 22 (2005). All specimens were tested at Auburn University. Neoprene pads were used for all compression tests. Fifty-durometer neoprene pads were used testing ages up to 4 days for the strength-maturity cylinders and for the 2,400-psi verification cylinders. For all other testing ages, 60 durometer neoprene pads were used. To stay consistent throughout all tests, a load rate of 60,000 lbs per minute was used.

5.4.3 DEVELOPING THE STRENGTH-MATURITY RELATIONSHIP

The original plan was to develop the strength-maturity relationships before the bridge deck was going to be placed. The strength-maturity relationship was developed a week before the first bridge deck was cast. The strengths estimated by the maturity method were then verified during the first segment placement for the I-85 Bridge. After the verification tests were conducted, it was discovered that a different concrete mixture was supplied to the bridge than the one used to develop the strength-maturity relationship. So it was then decided that a strength-maturity relationship would be developed from the concrete delivered to site for each of the remaining bridge deck placements.

Three different bridge deck placements were tested, and two strength-maturity relationships were created from the concrete placed in the structure for the second bridge deck segment of the I -85 Bridge and for the one segment of the Creek Bridge. To develop each strength-maturity relationship, 22 - 6 x 12 inch molded cylinders were made. In accordance with AASHTO T 23 (2004). Once the specimens were made and the plastic lids snapped on, the cylinders were cured under laboratory conditions as specified by ASTM C 1074. The strength-maturity cylinders were placed in field-curing boxes for

the first 24 to 48 hours. These field-curing boxes controlled the curing environment to stay between 60 and 80 °F. After 24 hours, the cylinders were transported to Auburn University, removed from the plastic molds, and placed in a moist-curing room. At each age, three cylinders were tested. The testing ages for the strength-maturity cylinders were: 1, 2, 3, 4, 7, 14, and 28 days.

Temperature recording devices were used to measure the temperature history of the molded cylinders used to develop the strength-maturity relationship. The iButtons that were used for the mock bridge deck, as described in Section 5.3.3.1, were also used for this phase of the project. An extra cylinder was cast each time so that an iButton could be installed, and that cylinder was not strength tested.

5.4.4 ESTIMATING THE IN-PLACE STRENGTH

iButtons were also used for the recording of the temperature history of the in-place concrete. At each location in the bridge decks as described in Section 5.1.3, three iButtons were installed: one at the top, middle, and bottom of the bridge deck. A two-wire, 20-gauge telephone wire was attached to the iButton with aluminum tape. One wire was attached to the top of the iButton and the other wire was attached to the bottom of the iButton. The three iButtons at each location were then connected in series like the iButton “Trees” described in Section 4.3.3.3 for the precast prestressed girder project. A single wire ran from each temperature sensing location in the bridge deck to the barrier wall reinforcement outside of the bridge deck. The wire was zip-tied to the bottom of the reinforcement steel in the bridge deck to avoid any damage to the wire. The iButtons installed in the bridge deck were suspended away from the reinforcement steel with an

insulated wire, which can be seen in Figure 5-19. In addition, iButtons were attached to the reinforcement steel at Locations 1 and 6 of the I-85 bridge and Location 3 of the Creel bridge deck to evaluate the effect that the temperature of the steel has on the temperature recorded with the iButtons. Figure 5-20 shows the end of the wire exiting the concrete with the phone jack attached to the computer to download the data.



Figure 5-19: iButtons installed in the bridge decks



Figure 5-20: iButton wires exiting the concrete

5.4.5 VERIFICATION TESTING

For the verification testing, seven cylinders were made from the concrete delivered to be placed at the designated location explained in Section 5.1.3. The cylinders were made in accordance with AASHTO T 23 (2004) and cured under laboratory conditions. The testing ages for the verification tests were (1) at the maturity when 2,400-psi is reached on the strength-maturity relationship, and (2) at an actual concrete age of 7 days. At each testing age, three cylinders were strength tested. Temperature-recording devices described in Section 5.3.3.1 were used to measure the temperature histories of the molded cylinders. The seventh cylinder was made each time so that an iButton could be installed, and that cylinder was not strength tested.

5.5 DATA ANALYSIS APPROACH

After all the data were collected, it was analyzed the same way as for the precast prestressed girder project in Section 4.3.5. All the temperature data were downloaded and outliers were removed from the strength data. The accumulation of the maturity was determined for the molded specimens, the mock bridge deck at the locations where the in-place tests were conducted, and the locations in the I-85 and Creek bridges. Strength-maturity relationships were developed from the strength and maturity data. Afterwards the accuracy of the maturity method was evaluated by assessing all the errors obtained between the measured and estimated strength. Confidence levels with a 10% defect level were applied to the best-fit strength-maturity relationship.

5.5.1 DATA INTERPRETATION

The same methods explained in Section 4.3.5.1 for the precast prestressed girder project were used to eliminate potential outliers in the strength data. The percent range, defined by Equation 2-11, was calculated for each test age of all testing methods conducted. If the range of testing results for three concrete cylinders cast under the field conditions was within 9.5%, then all specimens were used (AASHTO T 22 2005). The acceptable range for the pullout inserts are as follows: 31% for 5 pullouts inserts, 34% for 7 pullout inserts, and 36% for 10 pullout inserts (ASTM C 900 2001). Therefore 31% was used for the top, side, and bottom inserts of the mock bridge deck. The acceptable range for the pullout test performed on the molded cubes was 34%. For the cores the acceptable range for a single operator is 9% (AASHTO T 24 2002). Finally for cast-in-place cylinders, the acceptable range for a single operator is 10% (ASTM C 873 2004). If the percent range exceeded the allowable range, then the furthest outlier was removed, and the remaining test results were used

As was done for the precast prestressed girder project, some small adjustments were made to the first couple of temperatures recorded by the iButton. Hour Zero for all the tests was the time when the water contacted cement; therefore, the recorded temperatures that were taken between the times the water contacted cement at the batch plant and when the iButton sensors were covered with concrete were adjusted. The first temperature reading recorded after the sensor was covered with concrete was used for all temperatures prior to the time the water contacted cement. At most, this was 1 to 2 hours. In addition, the same adjustment that was explained in Section 4.3.5.1 for the precast prestressed girder project was done for the cores from the mock bridge deck. A transition

was made from the temperatures recorded in the mock bridge deck to the temperatures recorded from the iButton installed in the core after it was removed.

5.5.2 MATURITY CALCULATIONS

All maturity calculations were done in accordance with ASTM C 1074 (2004). The Nurse-Saul maturity function with datum temperatures of 0 °C and -10 °C were calculated with Equation 2-1. The Arrhenius maturity function, as defined by Equation 2-2, was determined with activation energies of 33,500 J/mol and 40,000 J/mol. A reference temperature of 22.8 °C (73 °F) and universal gas constant of 8.314 J/(mol x K) were used for the Arrhenius maturity function. Once strength testing of the specimens was conducted, the corresponding maturity at each age was calculated from the temperature history of each specimen type and in-place concrete.

5.5.3 STRENGTH-MATURITY RELATIONSHIPS

The strength-maturity relationships were calculated the same way as explained for the precast prestressed girder project in 4.3.5.3. All of the cylinder strength and maturity data at each testing age were used to create the strength-maturity relationship. The exponential function was used to define the strength-maturity relationship for the same reasons as explained in Section 4.3.5.3. The exponential function is defined by Equation 2-6.

5.5.4 CALCULATIONS OF ERRORS

Once all maturities have been calculated and the strength-maturity relationships have been established, the accuracy of the strength estimated with the maturity method can be

evaluated. The accuracy was determined by evaluating the percent error and the absolute average error as was done in the precast prestressed girder project. These error parameters between the strength obtained by testing molded cylinders and that estimated by the strength-maturity relationship were calculated. In addition, the error parameters were calculated for the strengths obtained from the in-place strength tests and those estimated by the maturity method. The percent error was calculated using Equation 4-2 and the average absolute error was calculated using Equation 4-3.

5.5.5 CONFIDENCE LEVELS

Confidence levels were applied to all of the strength-maturity relationships to develop a new strength-maturity relationship based on the desired defect level. The coefficient of variation for each type of test was used along with Equation 2.9 in Section 2.8.1 to apply the confidence levels to the original strength-maturity relationship. The confidence levels of 50%, 75%, and 90% and defect level of 10% were used to calculate the confidence levels as stated in Section 5.1.1.4. The corresponding K-values for the different confidence levels at a defect level of 10% are summarized in Table 2-3. Table 5-3 is the coefficient of variation for test data obtained from cylinders, cast-in-place cylinders, cores, and pullout inserts.

Table 5-3: Coefficient of variation of test methods

Test Method	Coefficient of Variation	Reference
Compression Testing of Molded Cylinders	2.9%	AASHTO T 22 (2005)
Compression Testing of CIPCylinders	3.5%	ASTM C 873 (2004)
Compression Testing of Cores	4.7%	AASHTO T 24 (2002)
Pullout Testing	8.0%	ASTM C 900 (2001)

5.5.6 ACCEPTANCE CRITERIA

To determine if the maturity method is an accurate method for evaluating the strength gain of concrete, the acceptance criteria established in Section 4.3.5.6 for the precast prestressed girder project were used. If the strength estimated with the maturity method exceeds the measured strength of the molded cylinders or cast-in-place cylinders by more than 10%, then the maturity method is not accurate. For evaluation of the pullout test and the compressive strength of cores, each test will be considered accurate if strength estimated with the maturity method exceeds the measured strength by 15% or less.

5.6 MOCK BRIDGE DECK RESULTS

All test results for the mock bridge deck are presented in this section. Discussions of the results are presented in Section 5.8. Tables of the errors and graphs that can be used to evaluate the accuracy of the maturity method are also presented in Section 5.8. As discussed in Section 5.5.1, outliers were removed from the data presented in this section. The average strengths at each test age for the molded cylinders, pullout tests, compressive tests of the cast-in-place cylinders, and compressive tests of the cores are presented in this section. All individual strength test results for the mock bridge deck are presented in Appendix C. In addition, some of temperature profiles for the mock bridge deck are presented in this section, and all temperatures profiles are presented in Appendix C. This section is subdivided into cold-weather placement test results and the warm-weather placement test results. For the rest of this chapter, the cylinders that were cured in the field in lime-saturated water-tank will be known as the “*water-tank*” cylinders.

5.6.1 COLD-WEATHER PLACEMENT TEST RESULTS

5.6.1.1 Fresh Concrete Properties

The cold-weather placement of the mock deck occurred on February 24, 2005 at 12:50 pm. The ambient temperature for the first 24 hours ranged from 43 to 63 °F. A 3-yd³ batch was delivered for the mock bridge deck and all the testing that was performed. All fresh concrete properties were taken after the concrete was delivered to the construction site. The total air content was 5.0%, which was acceptable for assessment of the accuracy of the maturity method. Table 5-4 summarizes the fresh concrete properties tested for the cold-weather placement of the mock bridge deck.

Table 5-4: Fresh concrete properties for the cold-weather placement mock bridge deck

Fresh Concrete Properties	Results
Air (%)	5.0%
Slump (in.)	2.75
Temperature (°F)	77

5.6.1.2 Temperature Data

The temperature history of the 6 x 12 inch laboratory and water-tank cylinders and mock bridge deck are shown in Figure 5-21. The temperature history of the pullout cubes, 28-day CIP cylinders, and 4 x 8 inch molded cylinders are shown in Figure 5-22. The maximum temperatures and the minimum temperatures from the mid-depth temperature sensors are shown in this section. Only the first seven days were plotted because thereafter all of the specimens (excluding the laboratory cured specimens) closely followed the ambient temperature cycle.

A substantial difference between the laboratory-cured specimens and the field-cured specimens occurred over the entire period. The laboratory cured specimens never gave a temperature history close to the mock bridge deck temperature for the first 7 days. Even though the temperatures from the field-cured specimens did not reach the maximum temperature recorded in the mock bridge deck for the first 4 days, they did follow the mock bridge deck temperatures more closely than the laboratory specimens did after 4 days.

The temperature history of the 10-day, ASTM C 42 and AASHTO T 24 cured cores are presented in Figure 5-23, and the temperature history of the 28-day, ASTM C 42 and AASHTO T 24 cured cores are shown in Figure 5-24.

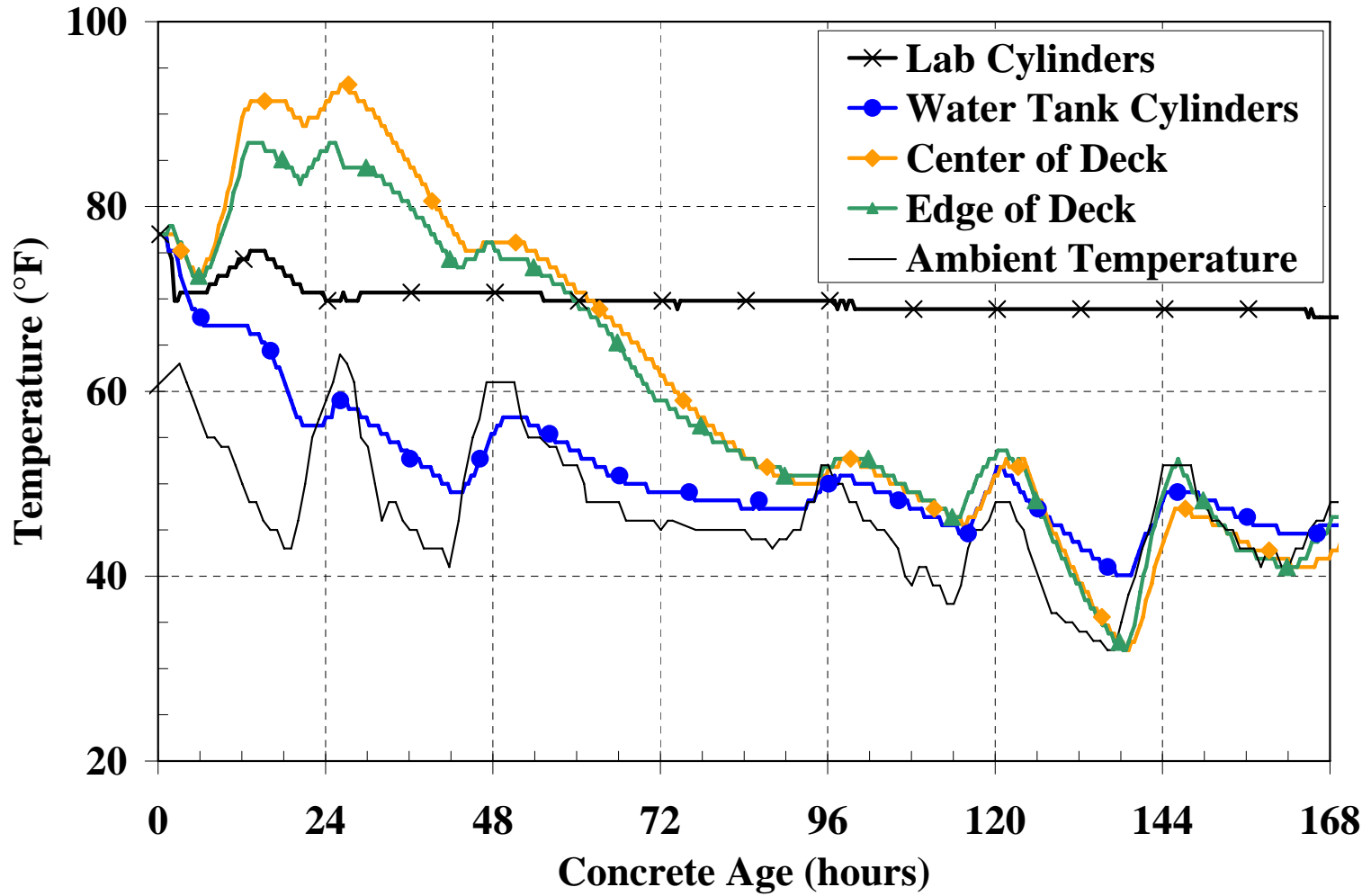

Figure 5-21: Temperature history of 6 x 12 inch cylinders and the mock bridge deck for the cold-weather placement

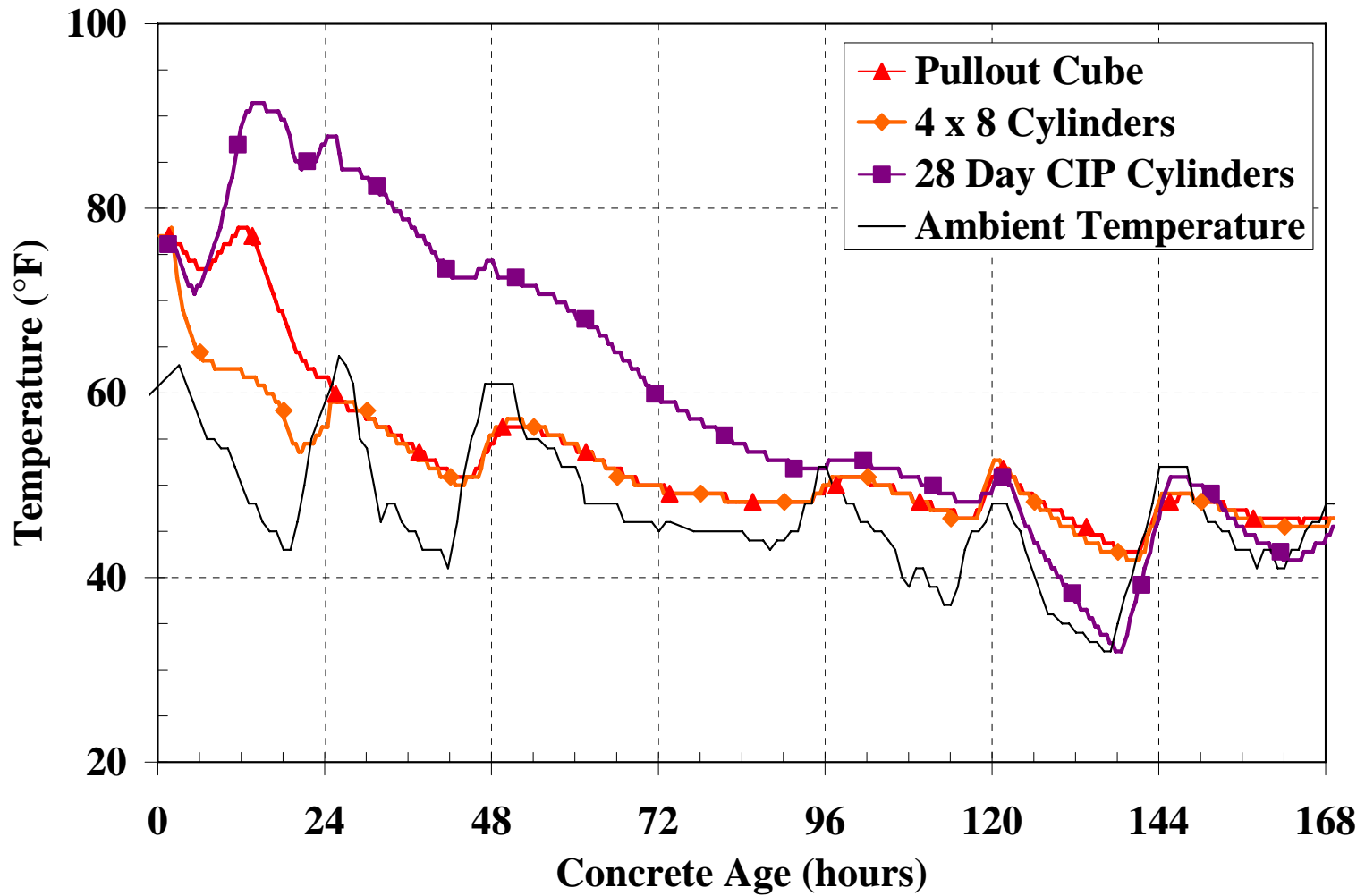

Figure 5-22: Temperature history of pullout cubes, 4 x 8 inch water-tank cylinders, and 28-day CIP cylinders for the cold-weather placement

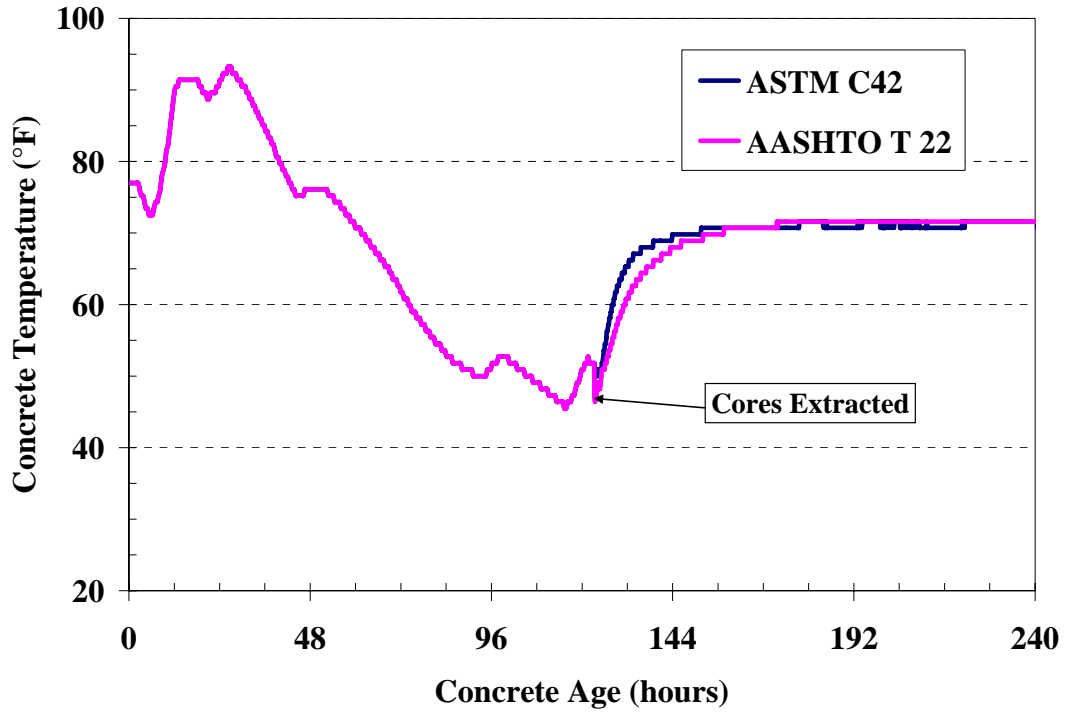

Figure 5-23: Temperature history of 10-day cores for cold-weather placement of mock bridge deck

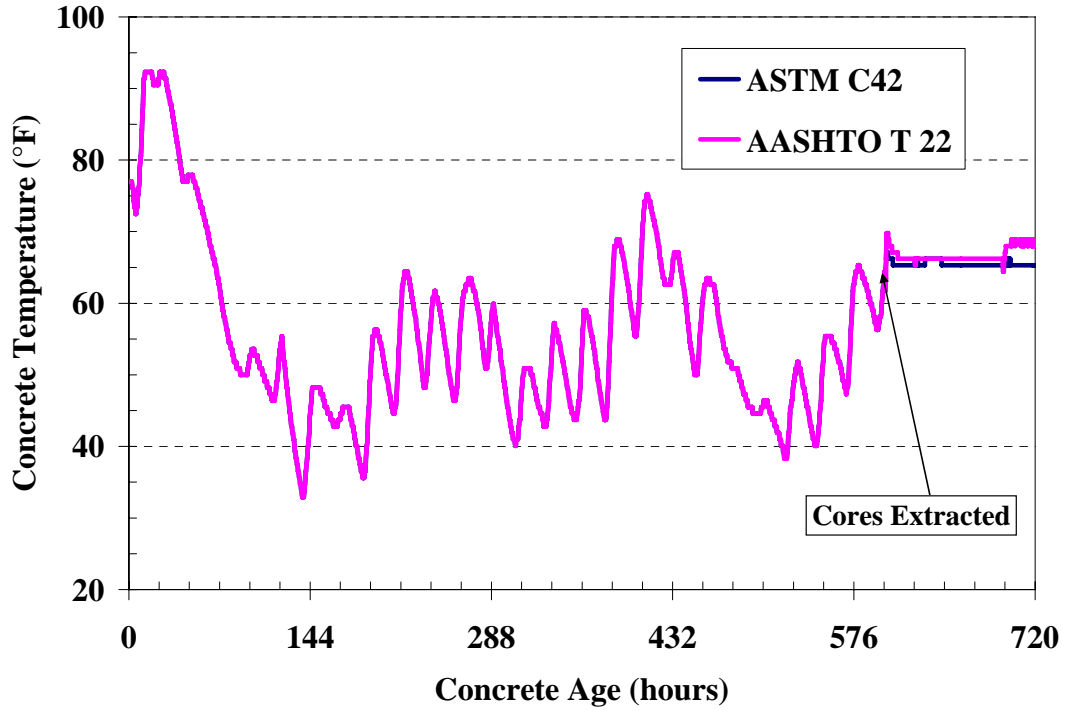

Figure 5-24: Temperature history of 28-day cores for cold-weather placement of mock bridge deck

5.6.1.3 Strength Data

The maturity values and strength test results for the laboratory-cured specimens are summarized in Table 5-5. No outliers were removed from the data set. A summary of the maturity and strength data for the 6 x 12 inch lime-saturated water-tank cured cylinders are presented in Table 5-6. Only one outlier was removed from the entire field cured set of cylinders, and it occurred in the one-day test data.

Table 5-5: Laboratory-cured cylinders strength and maturity data for cold-weather placement of mock bridge deck

Target Age (days)	Concrete Age (hours)	Nurse-Saul Maturity (°C • hours)		Arrhenius Maturity (hours)		Measured Strength (psi)
		T _o = -10 °C	T _o = 0 °C	E = 33.5 kJ/mol	E = 40 kJ/mol	
1	26.8	861	596	26.2	26.1	1,030
2	49.4	1,569	1,078	47.3	47.0	2,050
3	73.6	2,321	1,589	69.7	69.1	2,630
7	170.3	5,292	3,589	157.5	155.1	3,690
14	336.9	10,269	6,904	303.2	297.1	4,330
28	672.4	20,329	13,605	597.7	584.3	5,020

Table 5-6: 6 x 12 inch Water-tank-cured cylinder strength and maturity data for the cold-weather placement of the mock bridge deck

Target Age (days)	Concrete Age (hours)	Nurse-Saul Maturity (°C • hours)		Arrhenius Maturity (hours)		Measured Strength (psi)
		T _o = -10 °C	T _o = 0 °C	E = 33.5 kJ/mol	E = 40 kJ/mol	
1	27.0	761	491	22.0	21.2	820
2	49.2	1,245	754	35.2	33.2	1,430
3	73.4	1,769	1,037	49.5	46.0	2,140
7	170.2	3,536	1,838	97.5	88.0	3,590
14	335.9	6,850	3,493	187.5	168.1	4,370
28	672.3	14,151	7,431	387.4	349.3	4,650

The strength development of molded cylinders is presented in Figure 5-25. The entire testing time was shown to illustrate the difference between the strength development of the water-tank-cured and laboratory-cured molded cylinders. The exponential function was used to characterize the strength development of the concrete. The corresponding best-fit S_u , β , and τ values that define the strength development graphs are present in Appendix C.

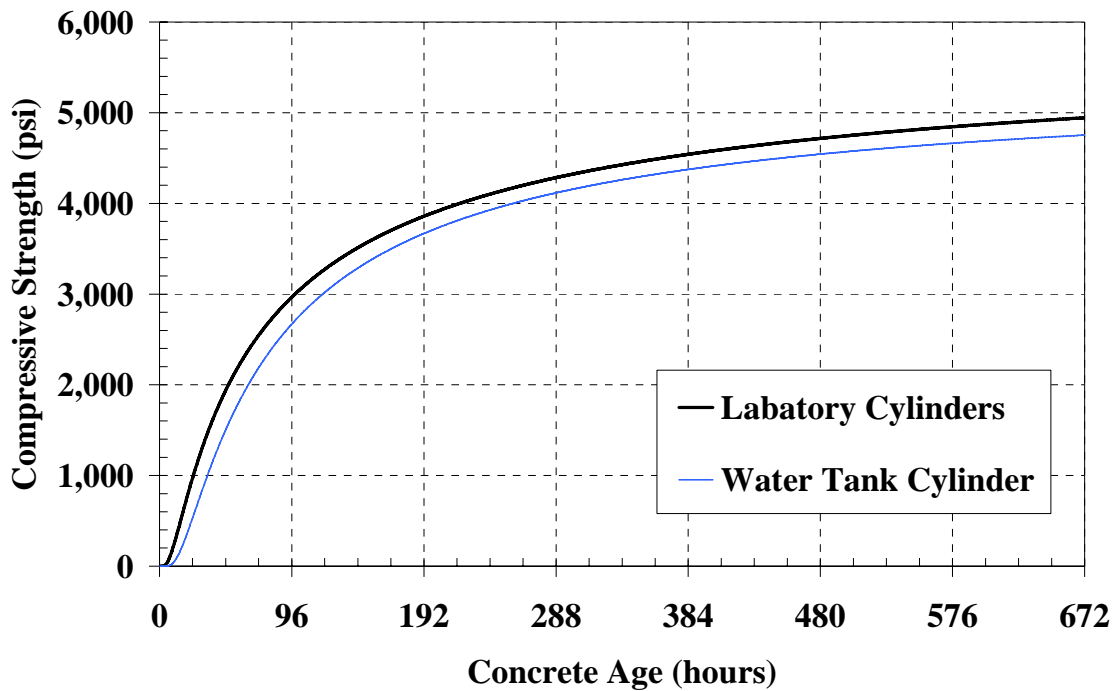

Figure 5-25: Concrete strength versus concrete age for cold-weather placement of mock bridge deck

The in-place strength and maturity data for the top pullouts are presented in Table 5-7, the side pullouts are presented in Table 5-8, and the bottom pullouts are presented in Table 5-9. All outliers were removed from the data sets. Some of side and bottom inserts were damaged during the construction process and were unable to be tested, while some

of the top inserts could not be tested because of problems that occurred with placing the floating inserts in the fresh concrete.

Table 5-7: In-place top pullout strength and maturity data for cold-weather placement of mock bridge deck

Target Age (days)	Concrete Age (hours)	Nurse-Saul Maturity (°C • hours)		Arrhenius Maturity (hours)		Pullout Compressive Strength (psi)
		T _o = -10 °C	T _o = 0 °C	E = 33.5 kJ/mol	E = 40 kJ/mol	
1	25.7	919	665	29.9	31.0	1,760
2	47.7	1,703	1,228	55.0	56.7	2,600
3	72.2	2,432	1,710	76.3	77.4	3,140
7	168.8	4,147	2,459	123.4	118.6	3,470
14	335.1	7,868	4,518	229.0	216.5	4,660
28	671.2	15,560	8,852	444.7	415.7	4,050

Table 5-8: In-place side pullout strength and maturity data for cold-weather placement of mock bridge deck

Target Age (days)	Concrete Age (hours)	Nurse-Saul Maturity (°C • hours)		Arrhenius Maturity (hours)		Pullout Compressive Strength (psi)
		T _o = -10 °C	T _o = 0 °C	E = 33.5 kJ/mol	E = 40 kJ/mol	
1	25.7	947	693	31.4	32.7	1,560
2	47.7	1,750	1,275	57.5	59.7	2,660
3	72.2	2,447	1,726	76.9	78.2	2,930
7	168.8	4,147	2,459	124.3	119.6	4,010
14	335.1	7,868	4,518	229.0	216.5	4,300
28	671.2	15,560	8,852	447.8	418.9	4,300

Table 5-9: In-place bottom pullout strength and maturity data for cold-weather placement of mock bridge deck

Target Age (days)	Concrete Age (hours)	Nurse-Saul Maturity (°C • hours)		Arrhenius Maturity (hours)		Pullout Compressive Strength (psi)
		T _o = -10 °C	T _o = 0 °C	E = 33.5 kJ/mol	E = 40 kJ/mol	
1	25.7	977	723	33.1	34.9	1,750
2	47.7	1,797	1,322	60.2	63.1	2,540
3	72.2	2,510	1,788	80.3	82.3	3,400
7	168.8	4,147	2,459	127.4	123.4	3,940
14	335.1	7,868	4,518	229.0	216.5	3,610
28	671.2	15,560	8,852	446.3	417.1	4,090

Core strengths and maturity data are summarized in Table 5-10 and Table 5-11.

Again all outliers were removed from the data set before the data analysis was conducted.

Also one core from the ASTM C 42 - 10-day and AASHTO T 24 - 10-day were not extracted from the mock bridge deck due to complications experienced with the coring barrel. For the AASHTO T 24 - 28-day cores, one core was removed due to being an outlier and for the ASTM C 42 – 28-day cores, two cores were removed due to being outliers. In Appendix C, the dimension of the cores and the layout of the core removal are reported.

Table 5-10: ASTM C 42 core strength and maturity data for the cold-weather placement of the mock bridge deck

Target Age (days)	Concrete Age (hours)	Nurse-Saul Maturity (°C • hours)		Arrhenius Maturity (hours)		Core Compressive Strength (psi)
		T _o = -10 °C	T _o = 0 °C	E = 33.5 kJ/mol	E = 40 kJ/mol	
10	10.2	7,448	5,006	227.8	226.9	4,070
28	30.0	17,662	10,351	508.1	479.5	4,650

Table 5-11: AASHTO T 24 core strength and maturity data for the cold-weather placement of the mock bridge deck

Target Age (days)	Concrete Age (hours)	Nurse-Saul Maturity (°C • hours)		Arrhenius Maturity (hours)		Core Compressive Strength (psi)
		T _o = -10 °C	T _o = 0 °C	E = 33.5 kJ/mol	E = 40 kJ/mol	
10	10.2	7,407	4,966	226.4	225.4	3,980
28	30.0	17,760	10,450	512.0	484.1	4,300

The pullout test results from the 8 x 8 x 8 inch cubes are presented in Table 5-12.

Two outliers were removed from the data set, one at 1 day and the other at 2 days.

Table 5-12: Pullout strength and maturity data from the cubes for cold-weather placement of mock bridge deck

Target Age (days)	Concrete Age (hours)	Nurse-Saul Maturity (°C • hours)		Arrhenius Maturity (hours)		Pullout Cube Compressive Strength (psi)
		T _o = -10 °C	T _o = 0 °C	E = 33.5 kJ/mol	E = 40 kJ/mol	
1	26.2	832	570	25.3	25.1	1,130
2	48.5	1,328	845	38.8	37.4	1,630
7	157.6	3,466	1,892	96.8	88.8	3,130

Strength and maturity data for the cast-in-place cylinders and water-tank-cured 4 x 8 inch cylinders are summarized in Table 5-13 and Table 5-14. All outliers were removed from the data set before the data analysis was conducted. For the CIP cylinders, one cylinder was not tested for the 2 day testing age due to the cylinder being defective after removal from the deck. In addition, one CIP cylinder was removed from both the 7- and 28-day test results due to being an outlier. For the water-tank 4 x 8 inch cylinders, one was removed from the 2 day testing age for being an outlier.

Table 5-13: CIP cylinders strength and maturity data for the cold-weather placement of the mock bridge deck

Target Age (days)	Concrete Age (hours)	Nurse-Saul Maturity (°C • hours)		Arrhenius Maturity (hours)		Compressive Strength (psi)
		T _o = -10 °C	T _o = 0 °C	E = 33.5 kJ/mol	E = 40 kJ/mol	
1	1.1	1,014	753	34.8	36.9	1,870
2	2.1	1,874	1,372	62.5	65.4	2,770
7	7.1	4,399	2,696	134.1	131.1	3,880
28	28.0	15,874	9,151	455.0	427.2	4,980

Table 5-14: 4 x 8 inch water-tank-cured cylinder strength and maturity data for the cold-weather placement of the mock bridge deck

Target Age (days)	Concrete Age (hours)	Nurse-Saul Maturity (°C • hours)		Arrhenius Maturity (hours)		Compressive Strength (psi)
		T _o = -10 °C	T _o = 0 °C	E = 33.5 kJ/mol	E = 40 kJ/mol	
1	1.1	710	444	20.2	19.3	760
2	2.1	1,231	732	34.4	32.2	1,330
7	7.1	3,554	1,851	97.5	87.8	3,460
28	28.0	14,149	7,429	386.5	348.1	4,970

5.6.1.4 Strength-Maturity (S-M) Relationships

The strength-maturity relationships for the cold-weather casting of the mock bridge deck were developed as stated in Section 5.5.3. The exponential function was used to characterize the strength-maturity relationship of the concrete. The best-fit S_u , β , and τ values and R^2 values are summarized in Appendix C. Four different S-M relationships were developed using the following maturity functions and corresponding temperature sensitivity values: Nurse-Saul maturity function with $T_o = -10$ °C and 0 °C and Arrhenius maturity function with $E =$ of 33,500 J/mol and 40,000 J/mol. The S-M

relationship with Nurse-Saul maturity function using $T_0 = -10\text{ }^\circ\text{C}$ is shown in Figure 5-26. The S-M relationship with Nurse-Saul maturity function using $T_0 = 0\text{ }^\circ\text{C}$ is shown in Figure 5-27. The S-M relationship with Arrhenius maturity function using $E = 33,500\text{ J/mol}$ is shown in Figure 5-28. The S-M relationship with Arrhenius maturity function using $E = 40,000\text{ J/mol}$ is shown in Figure 5-29.

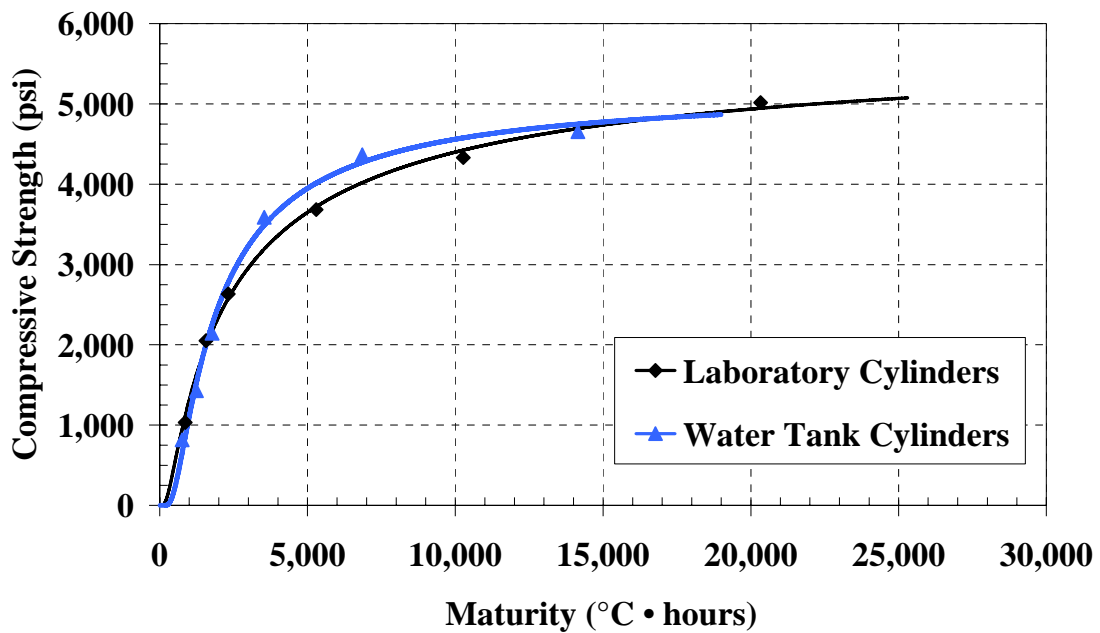

Figure 5-26: S-M relationships using the Nurse-Saul maturity function for mock bridge deck cold-weather placement ($T_0 = -10\text{ }^\circ\text{C}$)

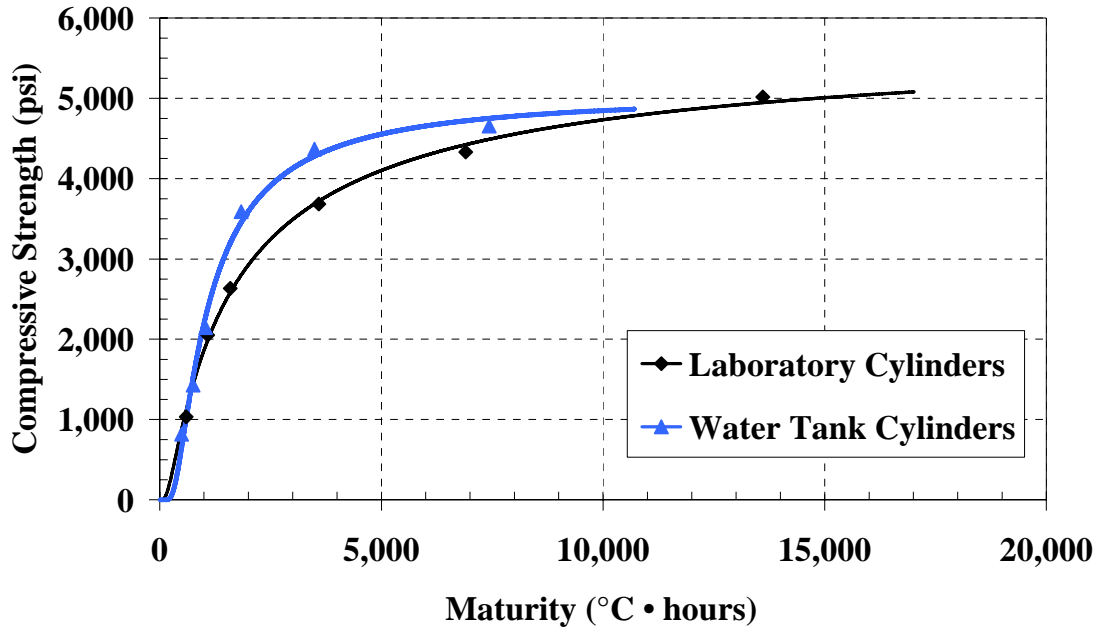

Figure 5-27: S-M relationships using the Nurse-Saul maturity function for mock bridge deck cold-weather placement ($T_0 = 0\text{ }^\circ\text{C}$)

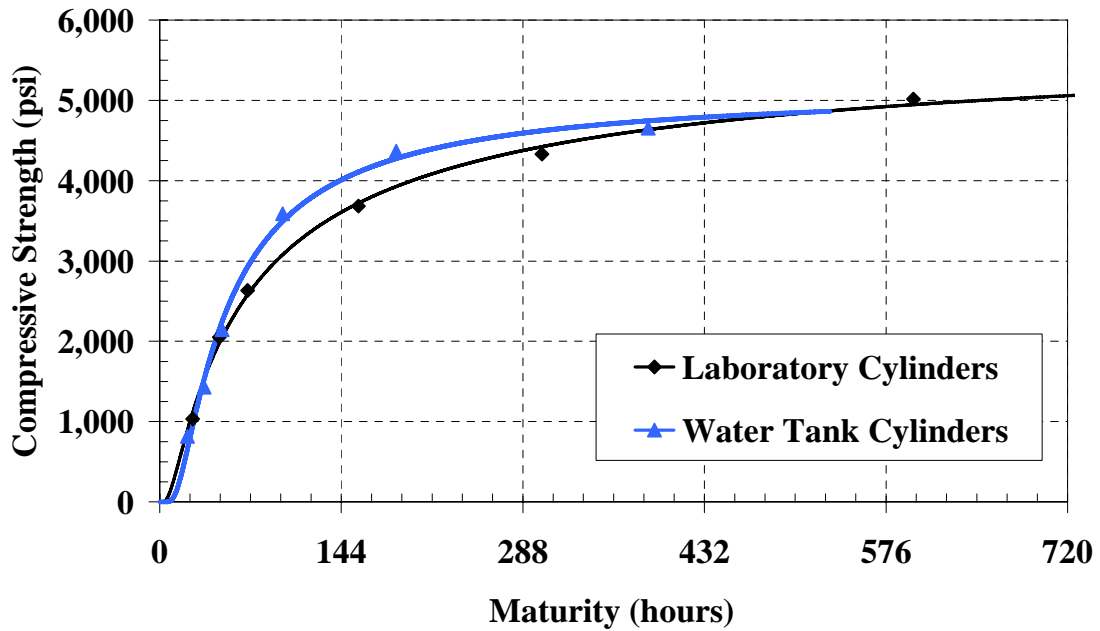

Figure 5-28: S-M relationships using the Arrhenius maturity function for mock bridge deck cold-weather placement ($E = 33.5\text{ kJ/mol}$)

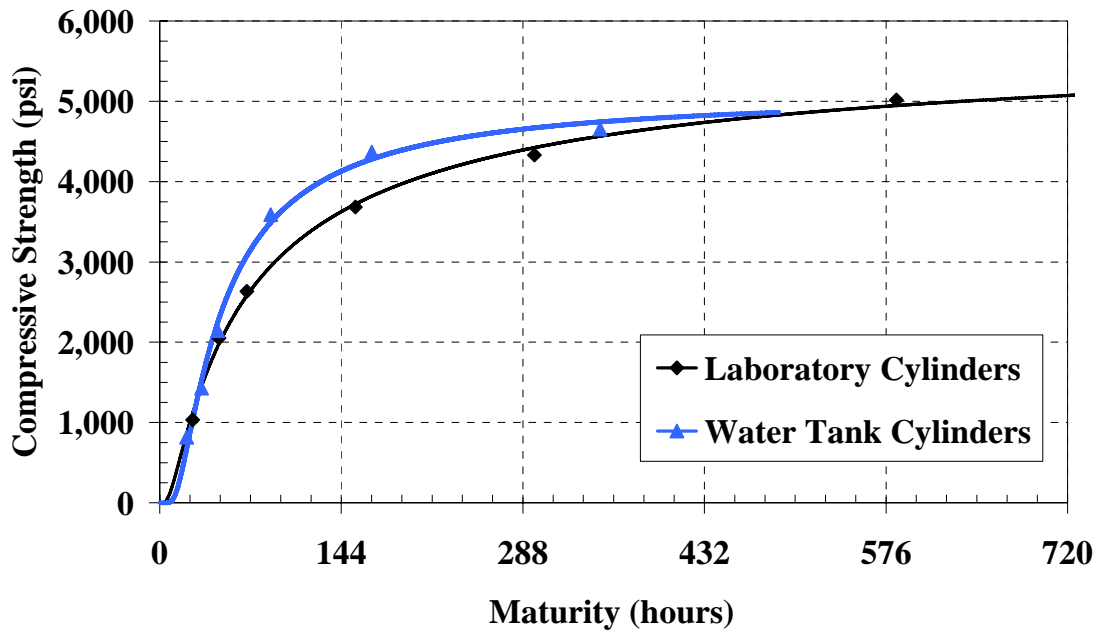

Figure 5-29: S-M relationships using the Arrhenius maturity function for mock bridge deck cold-weather placement ($E = 40$ kJ/mol)

In accordance with ASTM C 1074 (2004), the S-M relationship should be developed by using cylinders that were cured under laboratory conditions in accordance to ASTM C 192 (2002). Therefore, the laboratory-cured cylinder S-M relationship was graphed with the strength and maturity results for the water-tank-cured cylinders. The S-M relationships incorporating confidence levels of 50%, 75%, and 90% and are shown in Figures 5-30 to 5-33. The confidence levels were calculated as explained in Section 5.5.5.

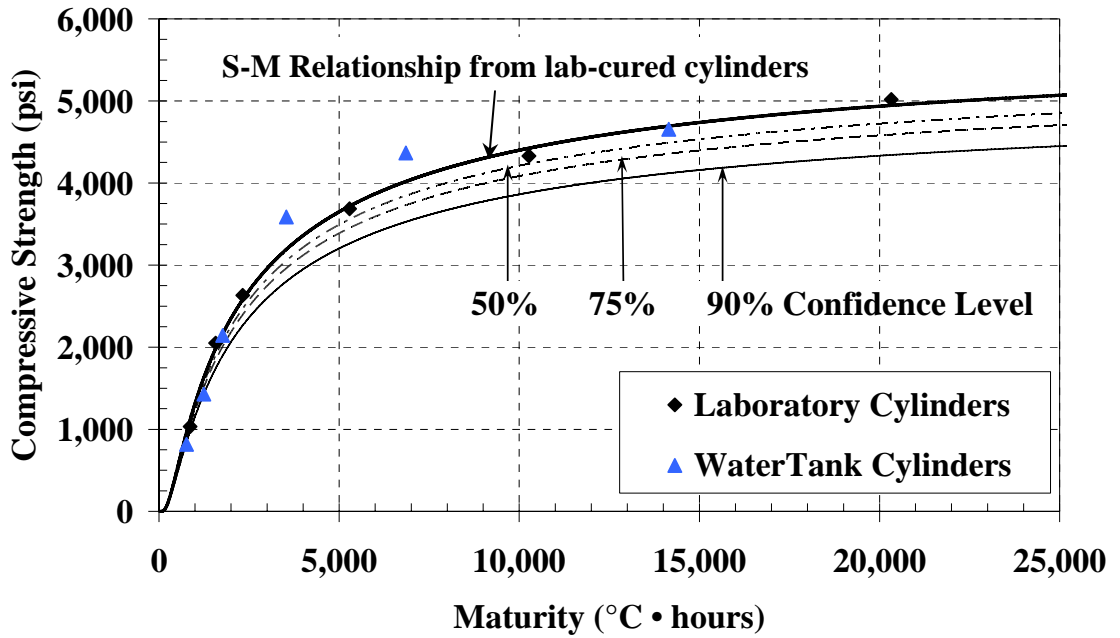

Figure 5-30: S-M relationship for the *laboratory* cured cylinders with confidence levels for the cold-weather placement of the mock bridge deck ($T_0 = -10^{\circ}\text{C}$)

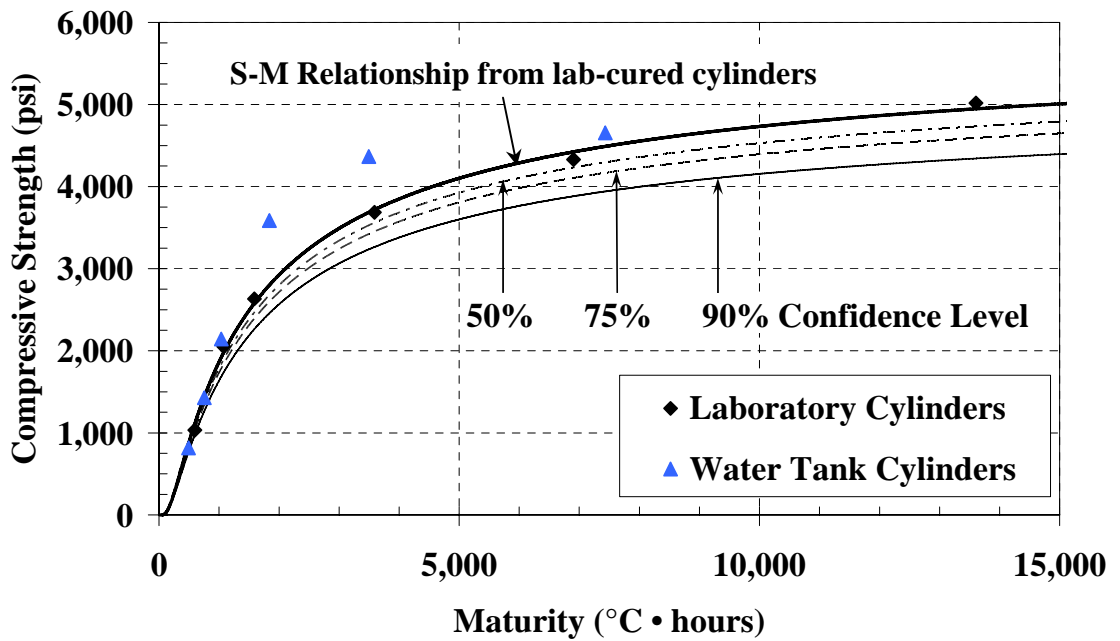

Figure 5-31: S-M relationship for the *laboratory* cured cylinders with confidence levels for the cold-weather placement of the mock bridge deck ($T_0 = 0^{\circ}\text{C}$)

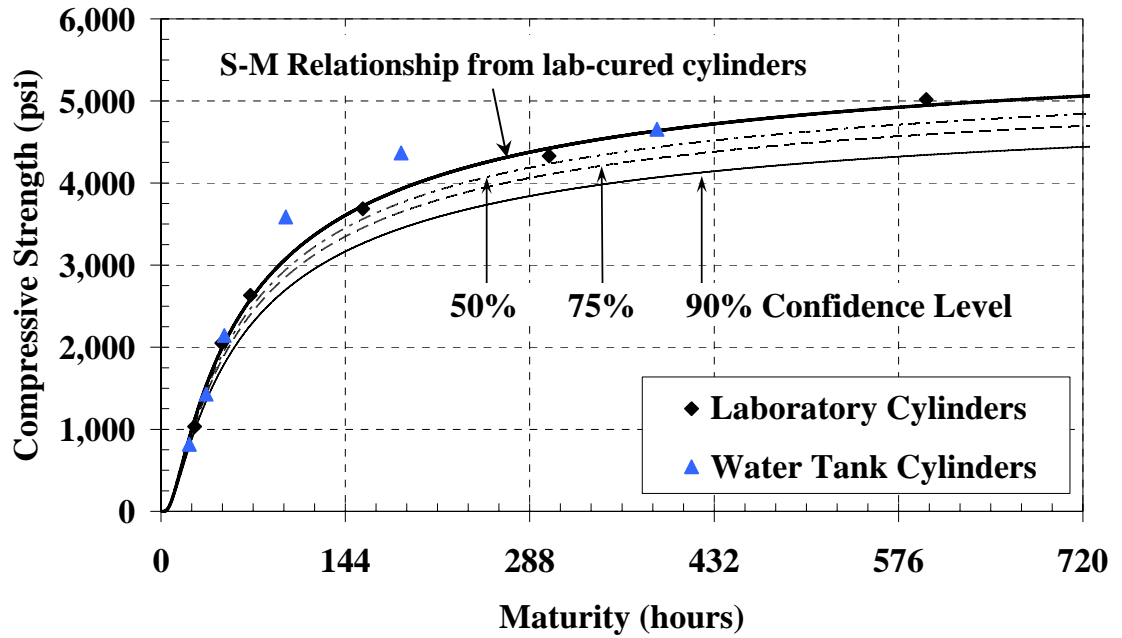

Figure 5-32: S-M relationship for the *laboratory* cured cylinders with confidence levels for the cold-weather placement of the mock bridge deck ($E = 33.5$ kJ/mol)

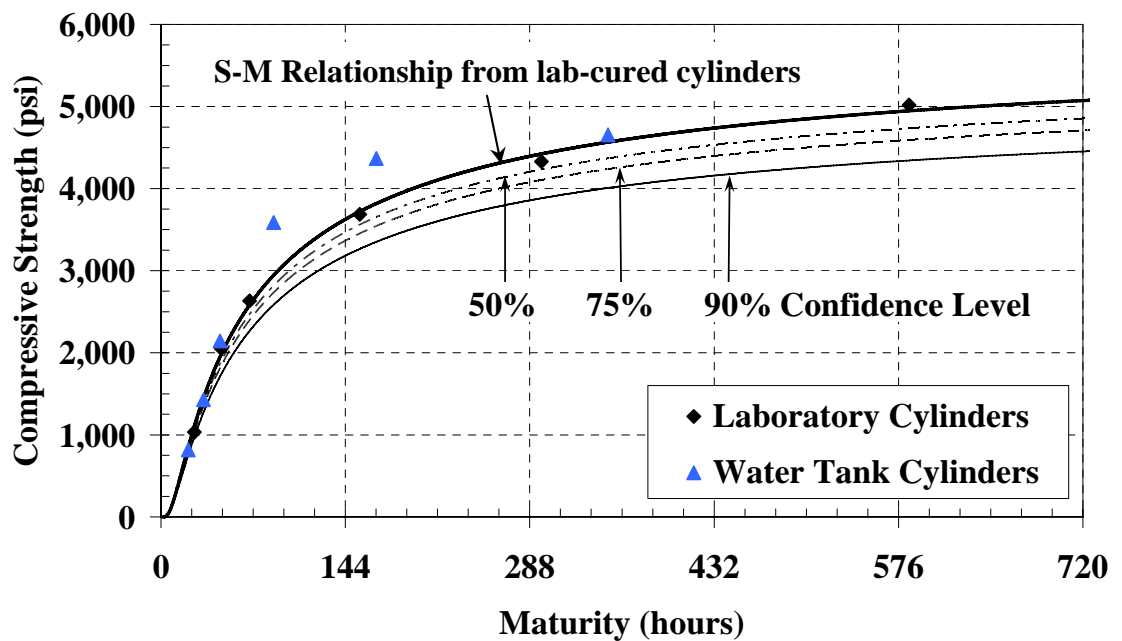

Figure 5-33: S-M relationship for the *laboratory* cured cylinders with confidence levels for the cold-weather placement of the mock bridge deck ($E = 40$ kJ/mol)

To evaluate whether the water-tank-cured cylinders would better represent the concrete's S-M relationship, the procedure that was used for the laboratory-cured cylinders was used for the water-tank-cured cylinders. These S-M relationships are presented in Appendix C. The 4 x 8 inch water-tank-cured cylinders data were added with the cast-in-place cylinder data to the laboratory and water-tank S-M relationships because the confidence levels for these were the similar. These graphs are presented in the next section.

5.6.1.5 In-Place Strength Graphs

To evaluate the in-place strength of the mock girder, pullout tests, compressive tests of cast-in-place cylinders, and compressive tests of cores were used. The strength and maturities of the tests were graphed against both S-M relationships that were developed from the concrete cylinders cured under different conditions. All four maturities were evaluated: Nurse-Saul maturity function with $T_0 = -10\text{ }^\circ\text{C}$ and $0\text{ }^\circ\text{C}$ and Arrhenius maturity function with $E = 33.5\text{ kJ/mol}$ and 40 kJ/mol . Along with the S-M relationship, the confidence levels of 50%, 75%, and 90% were also added to the graphs. The confidence levels for the pullout tests, cast-in-place cylinders, and cores are different due to the number of specimens and coefficient of variation of each test. For the following figures, the Nurse-Saul maturity function with $T_0 = 0\text{ }^\circ\text{C}$ and Arrhenius maturity function with $E = 33.5\text{ kJ/mol}$ are presented in this section. The Nurse-Saul maturity function with $T_0 = -10\text{ }^\circ\text{C}$ and Arrhenius maturity function with $E = 40\text{ kJ/mol}$ are presented in Appendix C.

The laboratory and water-tank-cured S-M relationship with the pullout compressive strengths are presented in Figure 5-34 to 5-37. The laboratory and water-tank cured S-M relationship with the compressive strengths of the cast-in-place cylinders are presented in Figure 5-38 to 5-41. Since the coefficient of variation of the cast-in-place cylinders and 4 x 8 inch molded cylinders are similar, the confidence levels for Figures 5-38 to 5-41 were calculated using the coefficients of variation of the 4 x 8 inch molded cylinders. The laboratory and water-tank-cured S-M relationship with the compressive strengths of the cores are presented in Figures 5-42 to 5-47.

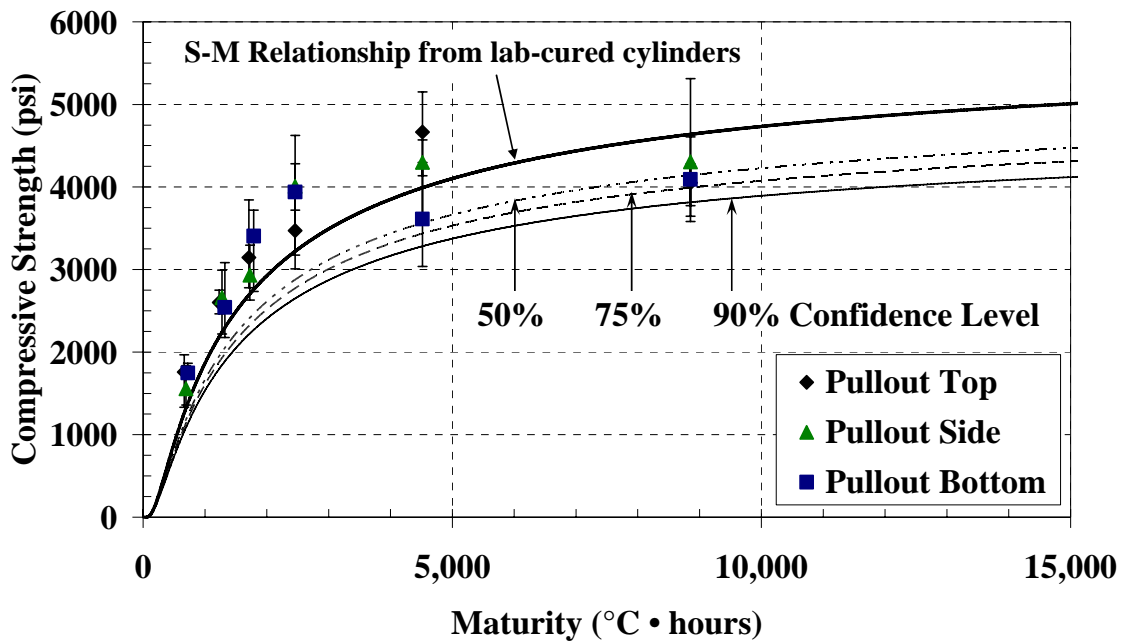

Figure 5-34: Pullout test with *laboratory* S-M relationship and confidence levels for the cold-weather placement of the mock bridge deck ($T_o = 0\text{ }^\circ\text{C}$)

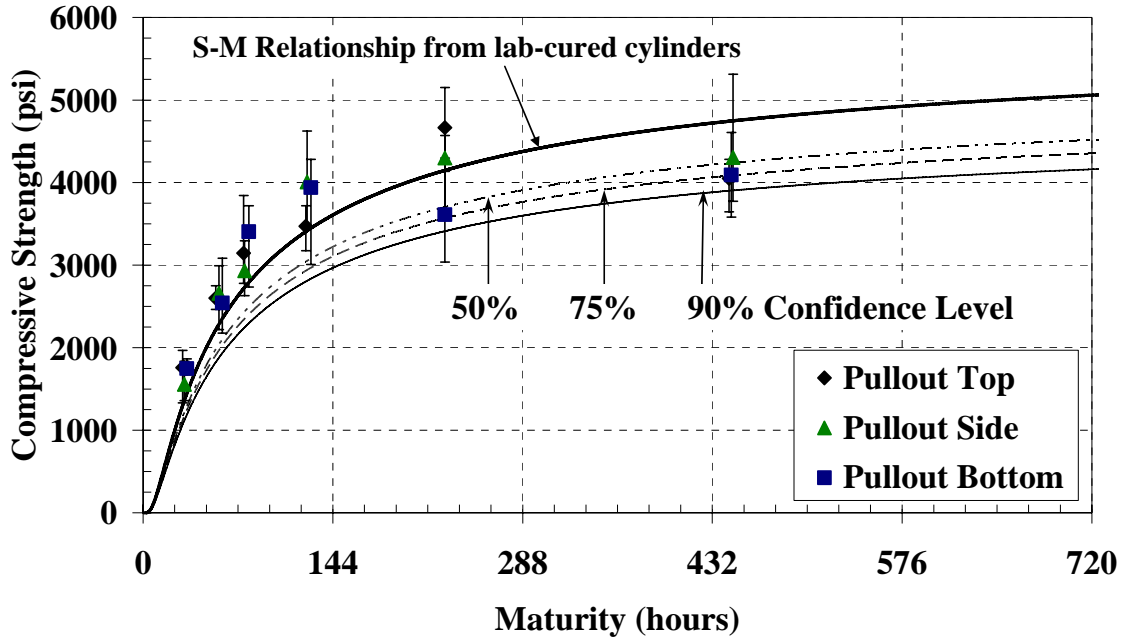

Figure 5-35: Pullout test with *laboratory* S-M relationship and confidence levels for the cold-weather placement of the mock bridge deck ($E = 33.5$ kJ/mol)

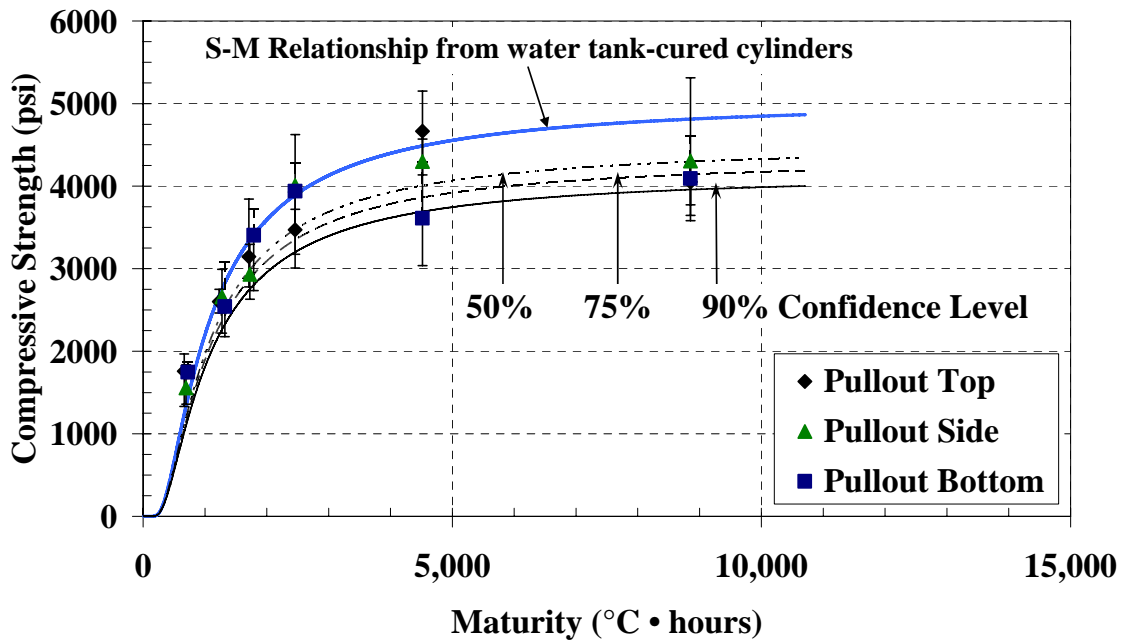

Figure 5-36: Pullout test with *water-tank* S-M relationship and confidence levels for the cold-weather placement of mock bridge deck ($T_o = 0^\circ\text{C}$)

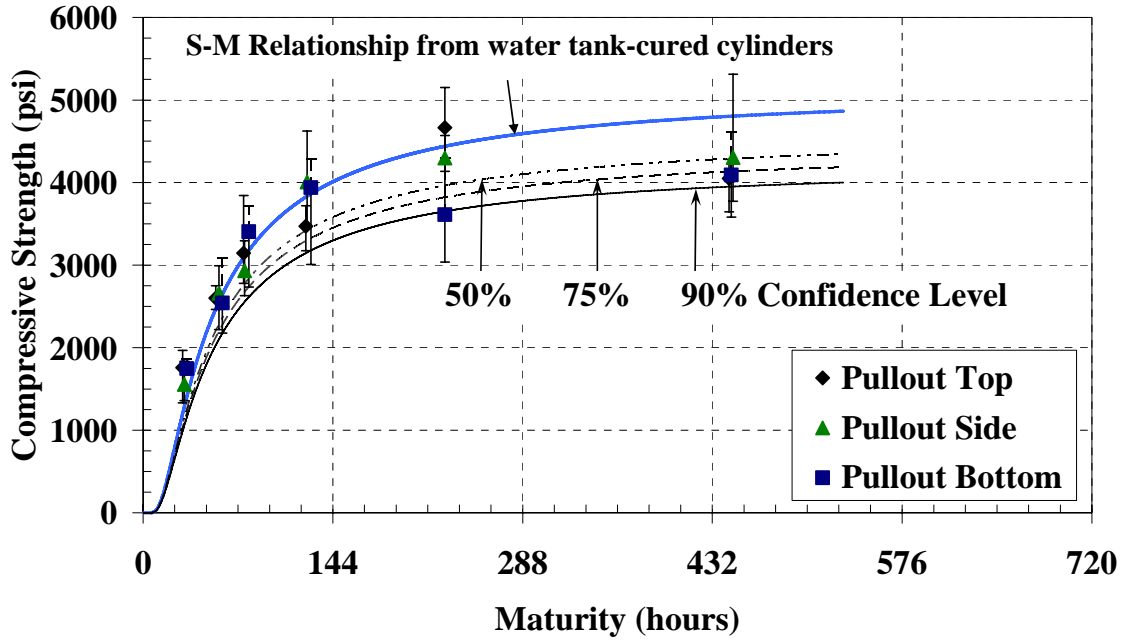

Figure 5-37: Pullout test with *water-tank* S-M relationship and confidence levels for the cold-weather placement of mock bridge deck ($E = 33.5$ kJ/mol)

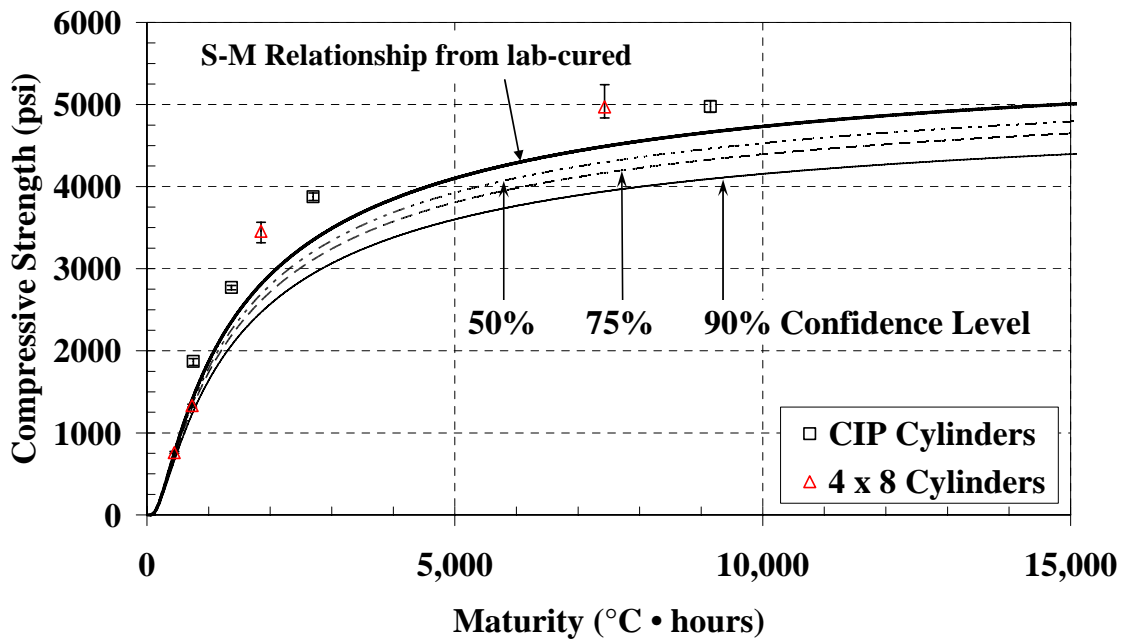

Figure 5-38: Cast-in-place cylinders and 4 x 8 inch cylinders with *laboratory* S-M relationship and confidence levels for the cold-weather placement of the mock bridge deck ($T_o = 0$ $^{\circ}\text{C}$)

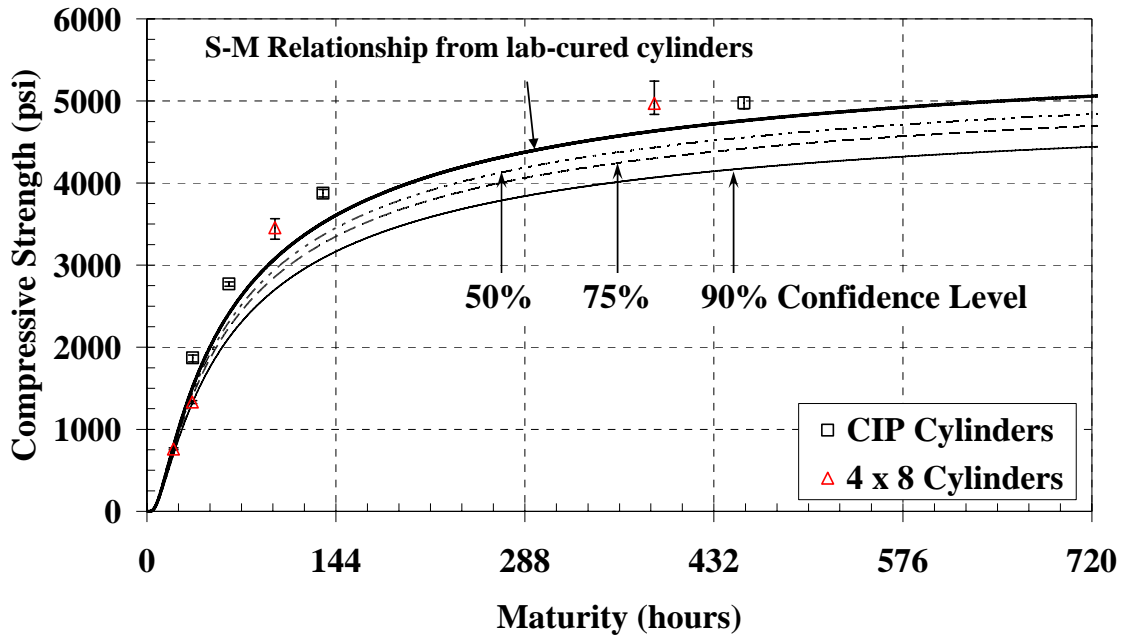

Figure 5-39: Cast-in-place cylinders and 4 x 8 inch cylinders with *laboratory* S-M relationship and confidence levels for the cold-weather placement of the mock bridge deck ($E = 33.5 \text{ kJ/mol}$)

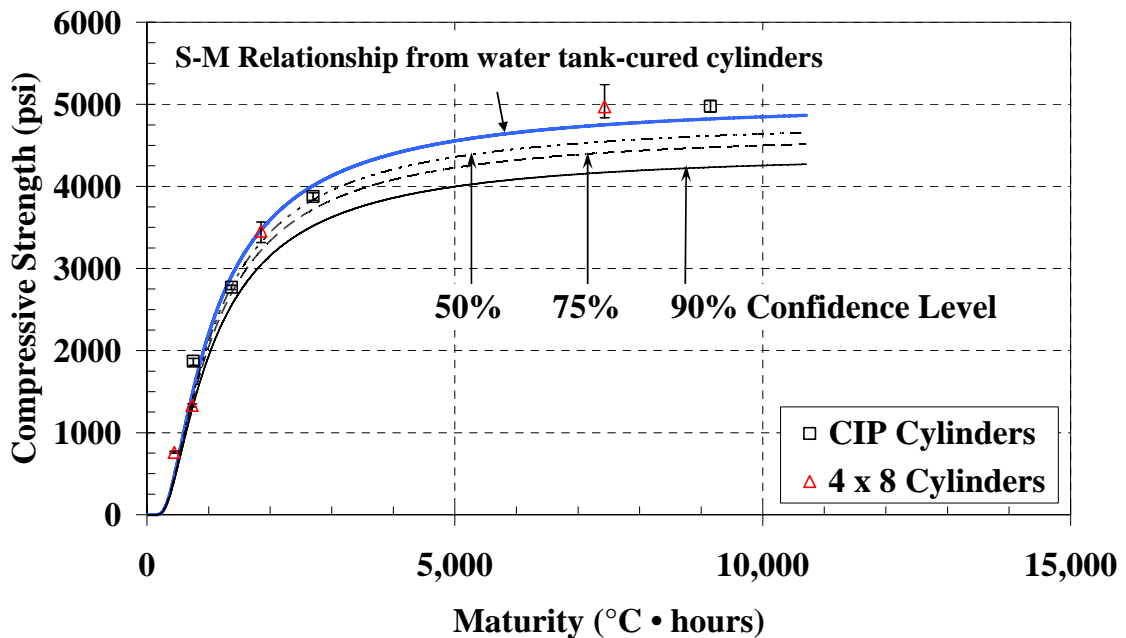

Figure 5-40: Cast-in-place cylinders and 4 x 8 inch cylinders with *water-tank* S-M relationship and confidence levels for the cold-weather placement of mock bridge deck ($T_o = 0^{\circ}\text{C}$)

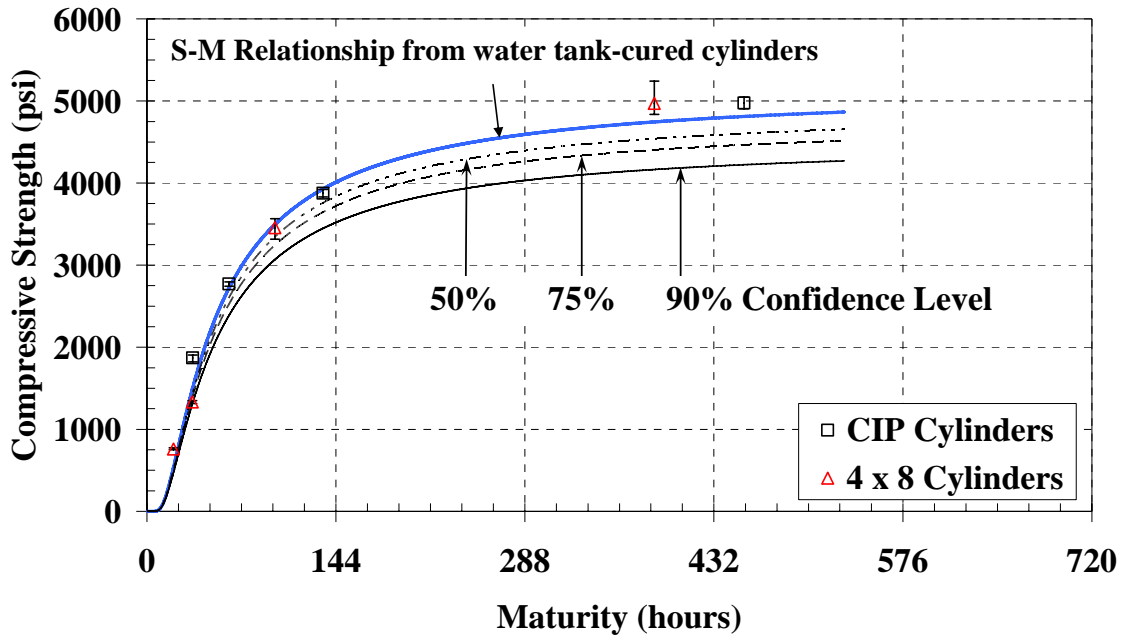

Figure 5-41: Cast-in-place cylinders and 4 x 8 inch cylinders with *water-tank* S-M relationship and confidence levels for the cold-weather placement of mock bridge deck ($E = 33.5 \text{ kJ/mol}$)

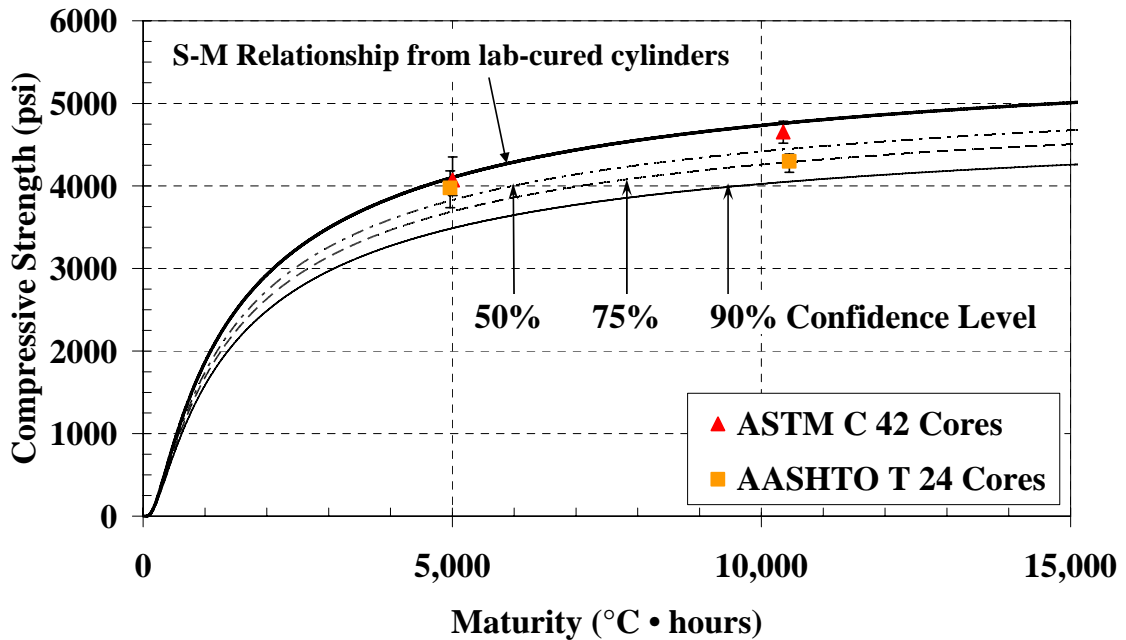

Figure 5-42: Cores with *laboratory* S-M relationship and confidence levels for the cold-weather placement of the mock bridge deck ($T_o = 0 \text{ }^{\circ}\text{C}$)

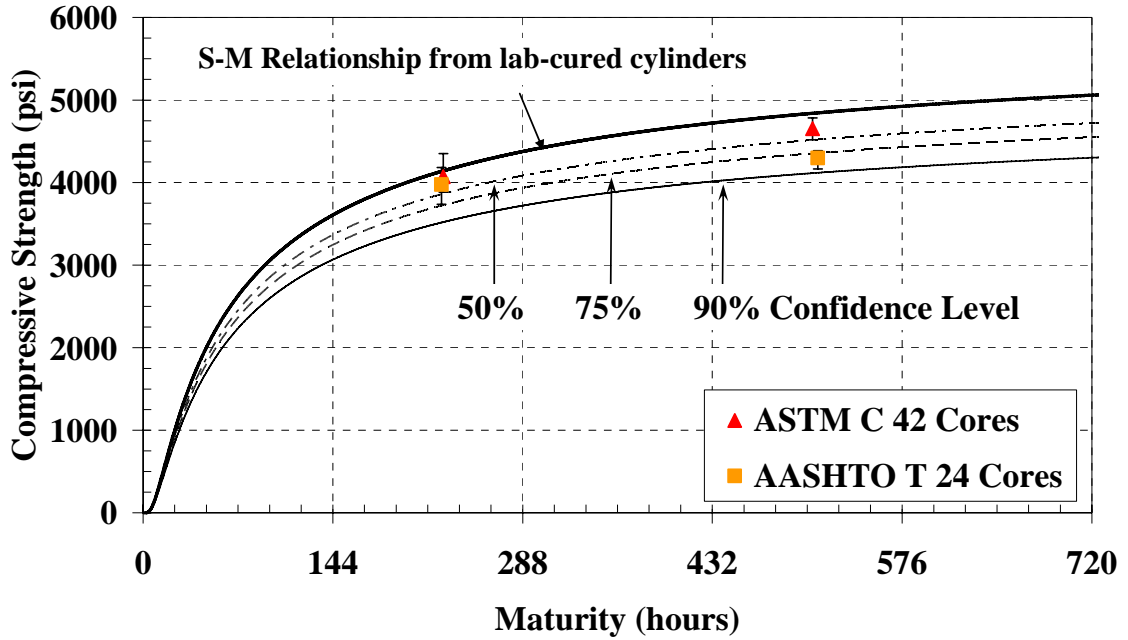

Figure 5-43: Cores with *laboratory* S-M relationship and confidence levels for the cold-weather placement of the mock bridge deck ($E = 33.5$ kJ/mol)

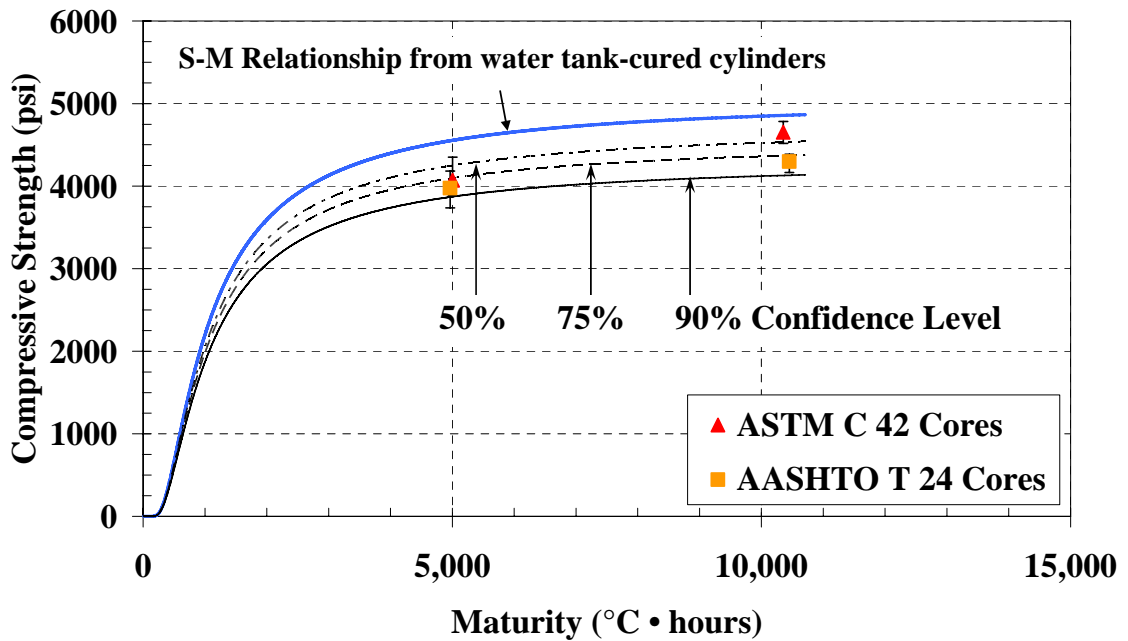

Figure 5-44: Cores with *water-tank* S-M relationship and confidence levels for the cold-weather placement of mock bridge deck ($T_o = 0^{\circ}\text{C}$)

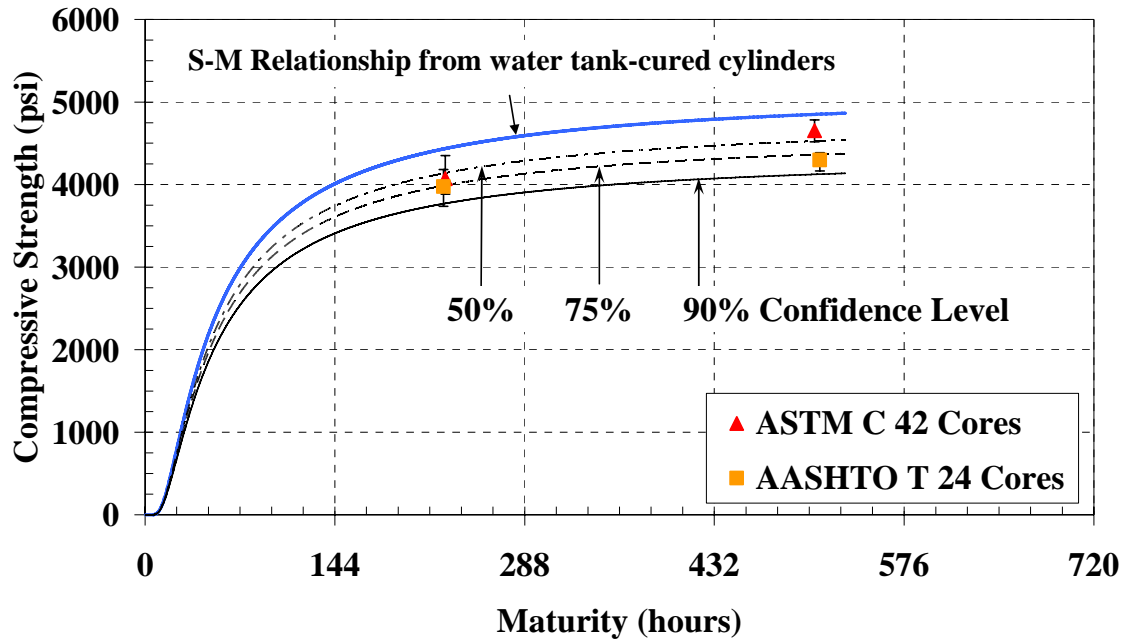

Figure 5-45: Cores with *water-tank* S-M relationship and confidence levels for the cold-weather placement of mock bridge deck ($E = 33.5$ kJ/mol)

5.6.2 WARM-WEATHER PLACEMENT TEST RESULTS

5.6.2.1 Fresh Concrete Properties

The warm-weather placement of the mock deck occurred on June 14, 2005 at 1:30 pm. The ambient temperature for the first 24 hours ranged from 75 to 90 °F. A 4-yd³ batch was delivered for the mock bridge deck and all the testing that was performed. Fresh concrete properties were taken after the concrete was delivered to the construction site and are summarized in Table 5-15. The total air content was 4.0% which was acceptable for assessment of the accuracy of the maturity method.

Table 5-15: Fresh concrete properties for the warm-weather placement mock bridge deck

Fresh Concrete Properties	Results
Air (%)	4.0%
Slump (in.)	2.5
Temperature (°F)	92

5.6.2.2 Temperature Data

The warm-weather placement of the mock bridge temperature histories of the 6 x 12 inch laboratory and water-tank cured cylinders and the mock bridge deck are presented in Figure 5-46. The temperature history of the pullout cubes, 4 x 8 inch cylinders, and 28-day CIP cylinders are presented in Figure 5-47. The maximum temperatures and the minimum temperatures recorded for the mock bridge deck are presented in Figure 5-46. The mid-depth temperature sensors were used for the mock bridge temperature histories presented here. Only the first seven days were plotted because thereafter all the specimens closely followed the ambient temperature cycle.

A difference occurs between the laboratory-cured specimens and the field-cured specimens but not as extensive as it was for the cold-weather placement. The field-cured temperatures to some extent followed the mock bridge deck recorded temperature but not to the same degree as found in the cold-weather placement of the mock bridge deck. Even though the temperatures from the field-cured specimens did not reach the temperatures recorded in the mock bridge deck for the first two days, they follow the recorded mock bridge deck temperatures more closely than do the laboratory specimens.

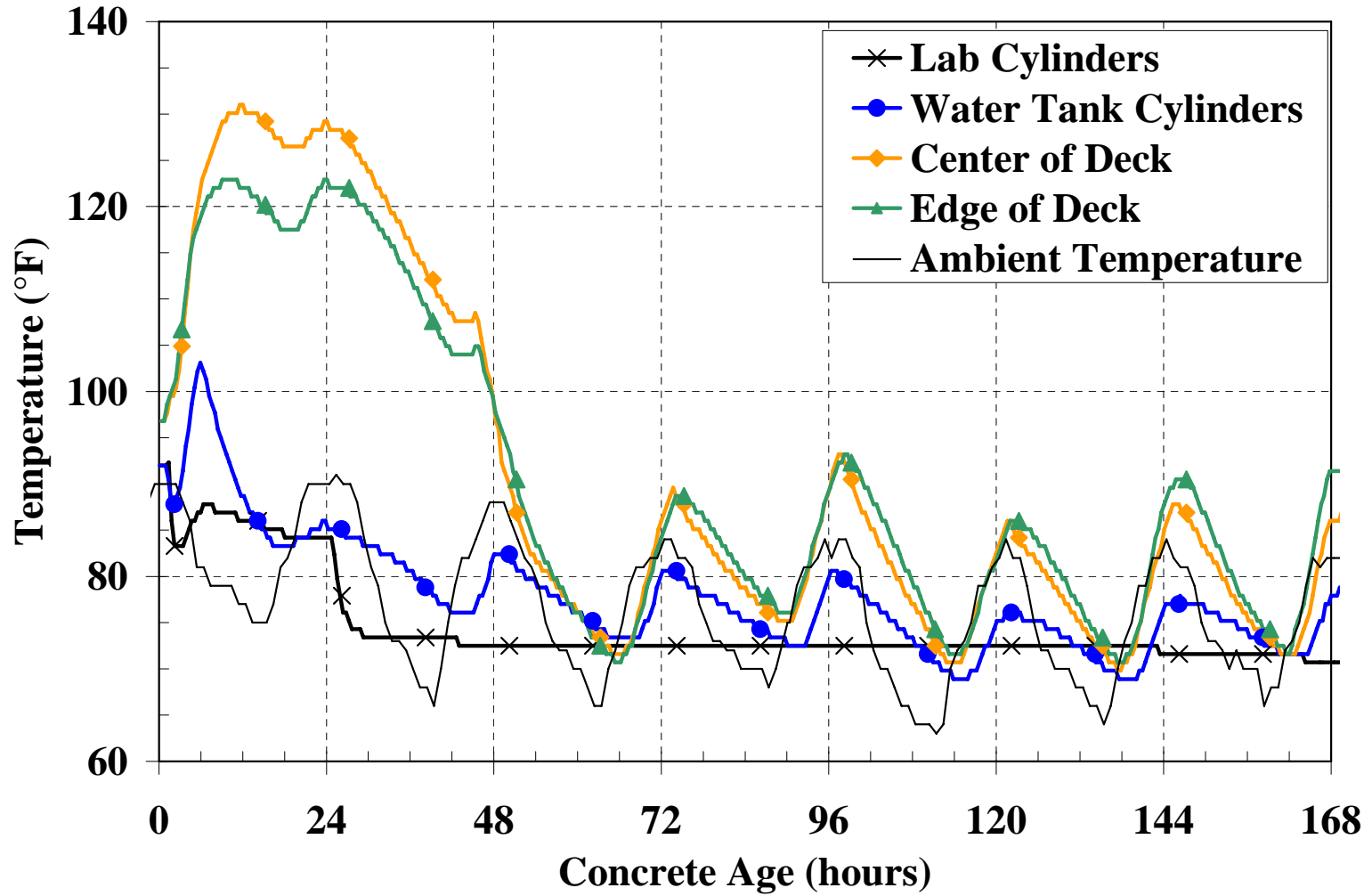

Figure 5-46: Temperature history of 6 x 12 inch cylinders and the mock bridge deck for the warm-weather placement

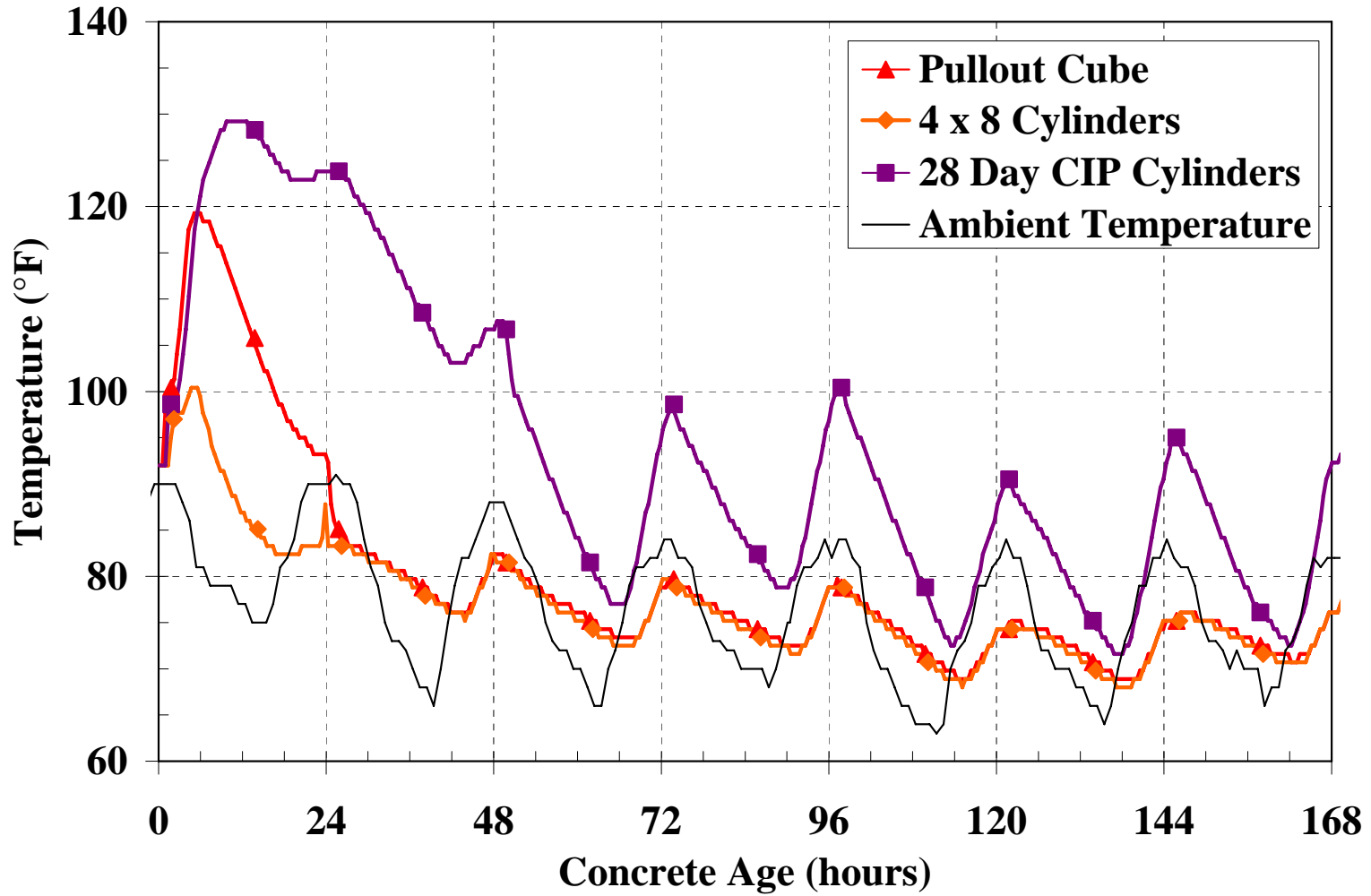

Figure 5-47: Temperature history of pullout cubes, 4 x 8 inch water-tank cylinders, and 28-day CIP cylinders for the warm-weather placement

The temperature history of the 7-day ASTM C 42 and AASHTO T 24 cured cores are presented in Figure 5-48. The temperature history of the 28-day ASTM C 42 and AASHTO T 24 cured cores are shown in Figure 5-49.

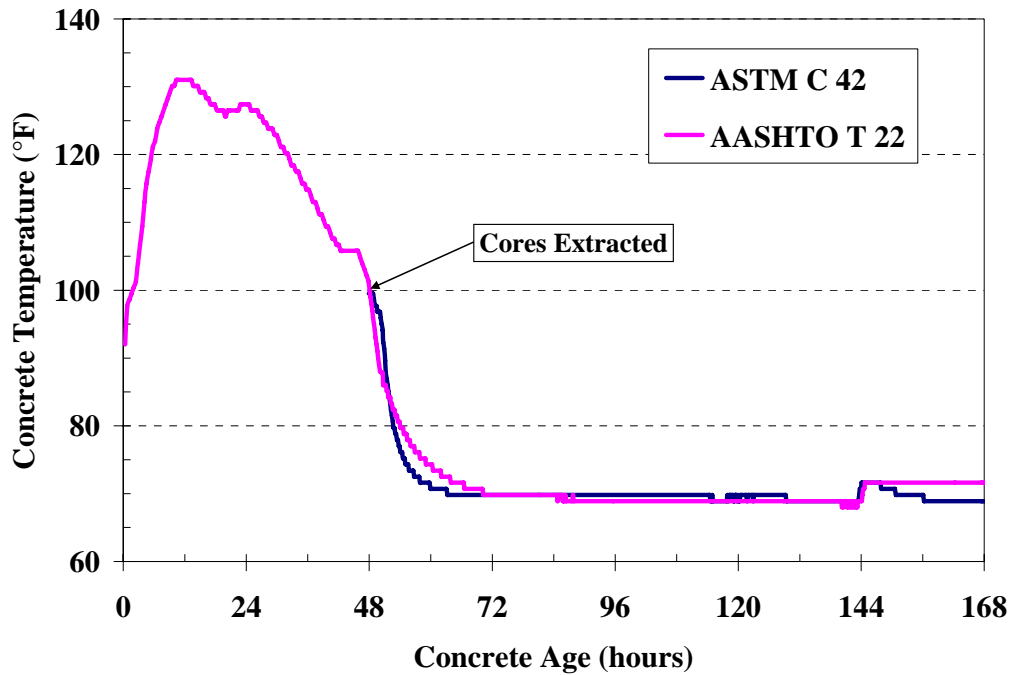

Figure 5-48: Temperature history of 7-day cores for warm-weather placement of mock bridge deck

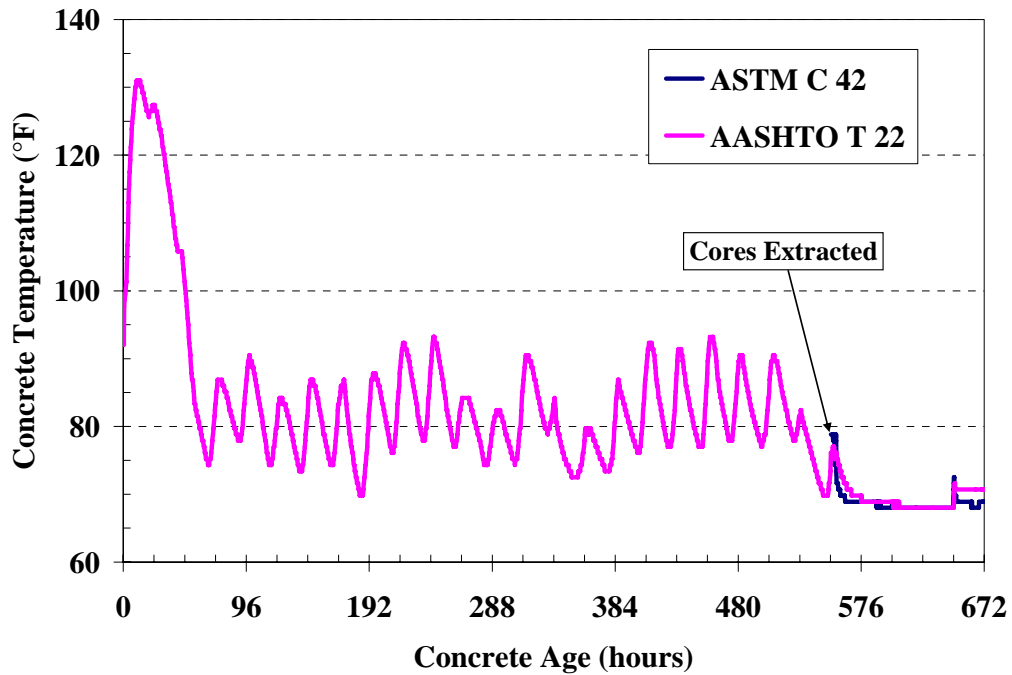

Figure 5-49: Temperature history of 28-day cores for warm-weather placement of mock bridge deck

5.6.2.3 Strength Data

The maturity values and strength test results for the laboratory-cured specimens are summarized in Table 5-16. No outliers were removed from the data set. A summary of the maturity and strength data for the 6 x 12 inch water-tank cured cylinders are presented in Table 5-17. Only one outlier was removed from the entire water-tank-cured set of cylinders, it was for the one-day testing age.

Table 5-16: Laboratory-cured cylinders strength and maturity data for warm-weather placement of mock bridge deck

Target Age (days)	Concrete Age (hours)	Nurse-Saul Maturity (°C • hours)		Arrhenius Maturity (hours)		Measured Strength (psi)
		T _o = -10 °C	T _o = 0 °C	E = 33.5 kJ/mol	E = 40 kJ/mol	
1	25.6	1,018	762	35.1	37.4	2,020
2	50.3	1,830	1,328	60.0	62.3	3,020
3	72.3	2,547	1,825	81.8	84.1	3,330
7	170.1	5,700	4,003	177.4	179.2	4,040
14	336.1	10,937	7,577	334.1	334.2	4,950
28	674.2	21,598	14,859	653.3	649.9	5,970

Table 5-17: 6 x 12 inch water-tank-cured cylinder strength and maturity data for the warm-weather placement of the mock bridge deck

Target Age (days)	Concrete Age (hours)	Nurse-Saul Maturity (°C • hours)		Arrhenius Maturity (hours)		Measured Strength (psi)
		T _o = -10 °C	T _o = 0 °C	E = 33.5 kJ/mol	E = 40 kJ/mol	
1	25.4	1,051	800	38.0	41.3	1,960
2	49.0	1,928	1,440	66.8	71.2	2,830
3	72.2	2,728	2,011	92.1	97.0	3,080
7	169.8	6,019	4,322	194.1	199.8	4,020
14	335.9	11,748	8,393	374.2	383.0	4,750
28	673.8	23,582	16,848	749.5	766.3	5,590

The strength development of the 6 x 12 inch molded cylinders is presented in Figure 5-50. The entire testing time is shown to illustrate the difference between the strength development of the water-tank-cured and laboratory-cured molded cylinders. The exponential function was used to characterize the strength gain of the concrete. The corresponding best-fit S_u , β , and τ values that define the strength development graphs are presented in Appendix C.

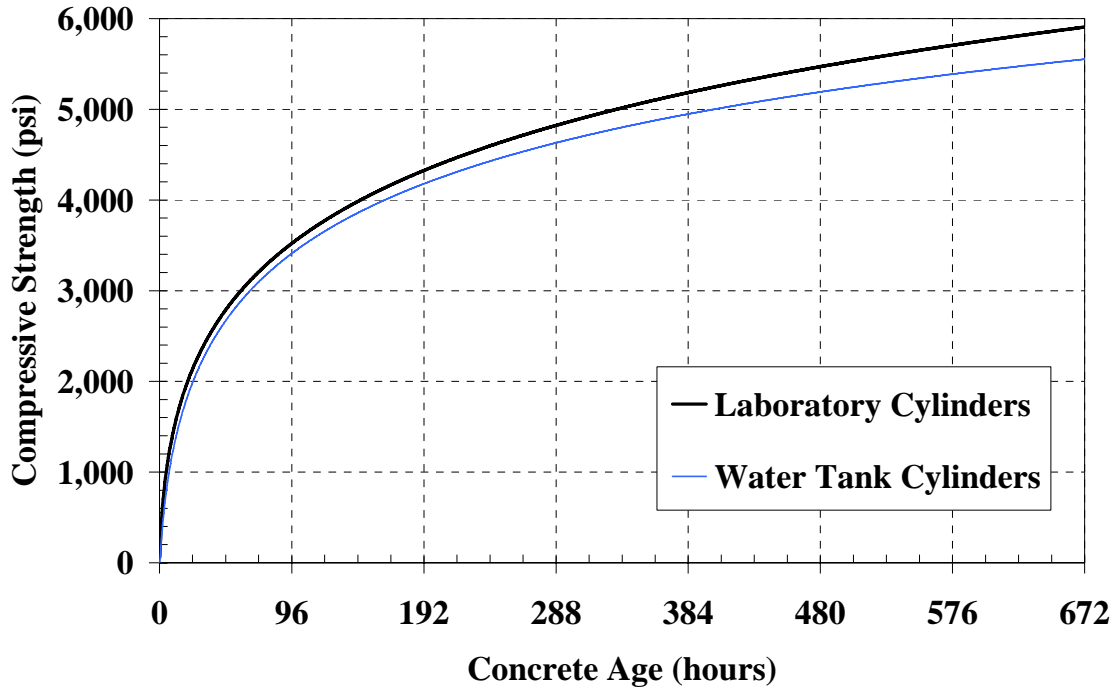

Figure 5-50: Concrete strength versus concrete age for warm-weather placement of mock bridge deck

The in-place strength and maturity data for the top pullouts are presented in Table 5-18, the side pullouts are presented in Table 5-19, and the bottom pullouts are presented in Table 5-20. All outliers were removed from the data sets. Some of side and bottom inserts were damaged during the construction process and could not to be tested, while some of the top inserts could not be tested because of problems that occurred with placing the floating inserts in the fresh concrete. All 28-day data for the side pullout tests were removed due to cracking that occurred during testing of those inserts. ASTM C 900 (2001) states that if cracking occurs that is not the same diameter as the bearing ring, then the test results must be discarded.

Table 5-18: In-place top pullout strength and maturity data for warm-weather placement of mock bridge deck

Target Age (days)	Concrete Age (hours)	Nurse-Saul Maturity (°C • hours)		Arrhenius Maturity (hours)		Pullout Compressive Strength (psi)
		T _o = -10 °C	T _o = 0 °C	E = 33.5 kJ/mol	E = 40 kJ/mol	
1	24.0	1,353	1,117	67.8	83.4	3,020
2	48.4	2,714	2,232	133.2	162.8	3,090
3	71.5	3,317	2,604	137.5	158.3	3,450
7	168.4	6,946	5,263	258.4	284.7	4,250
14	335.5	13,548	10,194	492.6	537.6	4,860
28	672.3	26,562	19,842	949.0	1027.3	6,210

Table 5-19: In-place side pullout strength and maturity data for warm-weather placement of mock bridge deck

Target Age (days)	Concrete Age (hours)	Nurse-Saul Maturity (°C • hours)		Arrhenius Maturity (hours)		Pullout Compressive Strength (psi)
		T _o = -10 °C	T _o = 0 °C	E = 33.5 kJ/mol	E = 40 kJ/mol	
1	24.0	1,351	1,115	67.4	82.8	2,590
2	48.4	2,693	2,210	130.7	159.0	3,430
3	71.5	3,397	2,685	144.2	167.5	3,420
7	168.4	6,949	5,265	259.4	286.7	3,720
14	335.5	13,548	10,194	492.6	537.6	4,250
28	672.3	26,562	19,842	933.9	1007.0	-

Table 5-20: In-place bottom pullout strength and maturity data for warm-weather placement of mock bridge deck

Target Age (days)	Concrete Age (hours)	Nurse-Saul Maturity (°C • hours)		Arrhenius Maturity (hours)		Pullout Compressive Strength (psi)
		T _o = -10 °C	T _o = 0 °C	E = 33.5 kJ/mol	E = 40 kJ/mol	
1	24.0	1,370	1,133	68.4	84.5	3,070
2	48.4	2,718	2,235	132.3	161.6	3,370
3	71.5	3,460	2,747	149.9	175.4	3,430
7	168.4	6,950	5,267	265.2	294.8	3,820
14	335.5	13,548	10,194	492.6	537.6	5,320
28	672.3	26,565	19,845	938.5	1012.4	5,310

Core strength and maturity data are summarized in Table 5-21 and Table 5-22. All outliers were removed from the data set before the data analysis was conducted. One core for both the ASTM C 42 – 28-day and AASHTO T 24 – 28-day cores was not extracted from the mock bridge deck due to complication that occurred during coring. In Appendix C, the individual strength test results, the dimension of the cores, and the layout of the cores are reported.

Table 5-21: ASTM C 42 core strength and maturity data for the warm-weather placement of the mock bridge deck

Target Age (days)	Concrete Age (hours)	Nurse-Saul Maturity (°C • hours)		Arrhenius Maturity (hours)		Core Compressive Strength (psi)
		T _o = -10 °C	T _o = 0 °C	E = 33.5 kJ/mol	E = 40 kJ/mol	
7	7.1	6,656	4,957	261.7	296.8	3,390
28	28.1	25,680	18,726	883.3	941.1	4,050

Table 5-22: AASHTO T 24 core strength and maturity data for the warm-weather placement of the mock bridge deck

Target Age (days)	Concrete Age (hours)	Nurse-Saul Maturity (°C • hours)		Arrhenius Maturity (hours)		Core Compressive Strength (psi)
		T _o = -10 °C	T _o = 0 °C	E = 33.5 kJ/mol	E = 40 kJ/mol	
7	7.1	6,666	4,965	260.8	295.1	3,180
28	28.1	25,696	18,872	891.2	953.0	4,040

The pullout test results obtained from the cube specimens are presented in Table 5-23. One of the tests for the 1-day test age was not conducted due to the insert not being perpendicular with the surface of the concrete.

Table 5-23: Pullout strength and maturity data from the cubes for warm-weather placement of mock bridge deck

Target Age (days)	Concrete Age (hours)	Nurse-Saul Maturity (°C • hours)		Arrhenius Maturity (hours)		Pullout Cube Compressive Strength (psi)
		T _o = -10 °C	T _o = 0 °C	E = 33.5 kJ/mol	E = 40 kJ/mol	
1	24.3	1,226	983	53.3	62.4	2,170
2	48.5	2,117	1,632	82.5	92.7	2,620
7	168.8	6,144	4,459	207.2	218.4	3,630

The cast-in-place (CIP) cylinders and water-tank-cured 4 x 8 inch cylinders strength and maturity data are summarized in Table 5-24 and Table 5-25. Again all outliers were removed from the data set before the data analysis was conducted. For the CIP cylinder, one test result was removed from the 1-day test age due to being an outlier. For the water-tank-cured 4 x 8 inch cylinders, one test result was removed from both the 1- and 28-day testing ages for being an outlier.

Table 5-24: CIP cylinders strength and maturity data for the warm-weather placement of the mock bridge deck

Target Age (days)	Concrete Age (hours)	Nurse-Saul Maturity (°C • hours)		Arrhenius Maturity (hours)		Compressive Strength (psi)
		T _o = -10 °C	T _o = 0 °C	E = 33.5 kJ/mol	E = 40 kJ/mol	
1	1.0	1,473	1,225	78.1	98.0	2,900
2	2.0	2,822	2,333	144.5	179.5	3,630
7	7.1	7,301	5,608	292.5	333.7	4,400
28	28.1	26,550	19,811	944.1	1020.4	4,790

Table 5-25: 4 x 8 inch *water-tank* cured cylinder strength and maturity data for the warm-weather placement of the mock bridge deck

Target Age (days)	Concrete Age (hours)	Nurse-Saul Maturity (°C • hours)		Arrhenius Maturity (hours)		Compressive Strength (psi)
		T _o = -10 °C	T _o = 0 °C	E = 33.5 kJ/mol	E = 40 kJ/mol	
1	1.0	1,044	793	37.6	40.7	2,030
2	2.0	1,895	1,411	65.2	69.3	2,850
7	7.1	5,921	4,228	189.4	194.2	4,240
28	28.1	23,193	16,459	730.1	742.6	5,990

5.6.2.4 Strength-Maturity (S-M) Relationships

The strength-maturity relationships for the warm-weather casting of the mock bridge deck were developed as for the cold-weather casting of the mock bridge deck as stated in Section 5.5.3. The exponential function was used to characterize the strength-maturity relationship of the concrete. The best-fit S_u , β , and τ values and R^2 values are summarized in Appendix C. The S-M relationship with Nurse-Saul maturity function using $T_o = -10$ °C is shown in Figure 5-51. The S-M relationship with Nurse-Saul maturity function using $T_o = 0$ °C is shown in Figure 5-52. The S-M relationship with Arrhenius maturity function using $E = 33,500$ J/mol is shown in Figure 5-53. The S-M relationship with Arrhenius maturity function using $E = 40,000$ J/mol is shown in Figure 5-54.

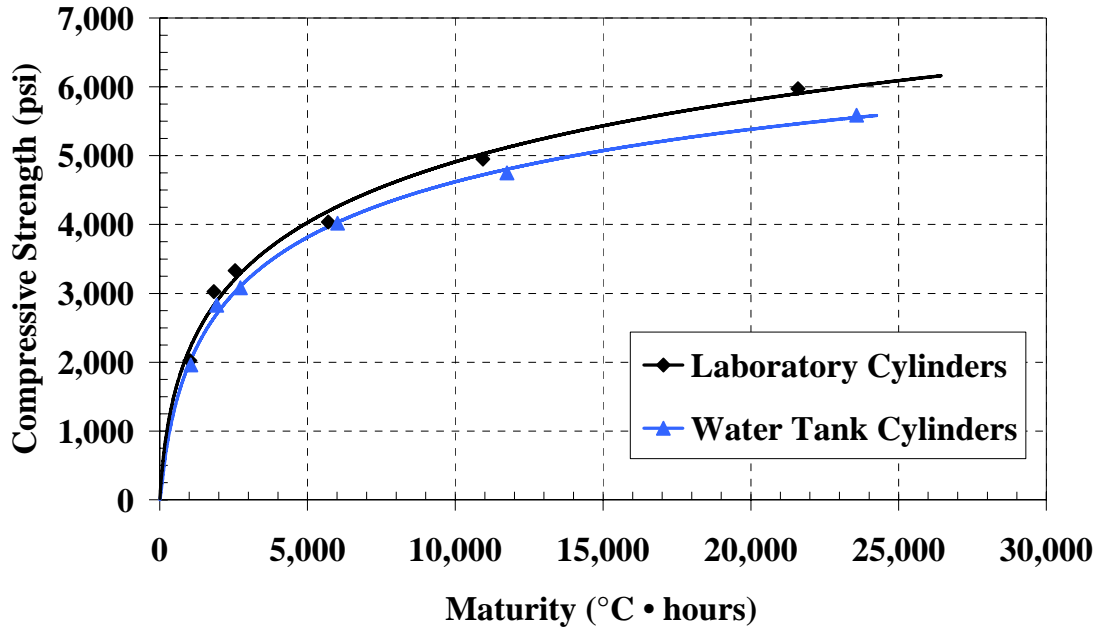

Figure 5-51: S-M relationships using the Nurse-Saul maturity function for mock bridge deck warm-weather placement ($T_0 = -10\text{ }^\circ\text{C}$)

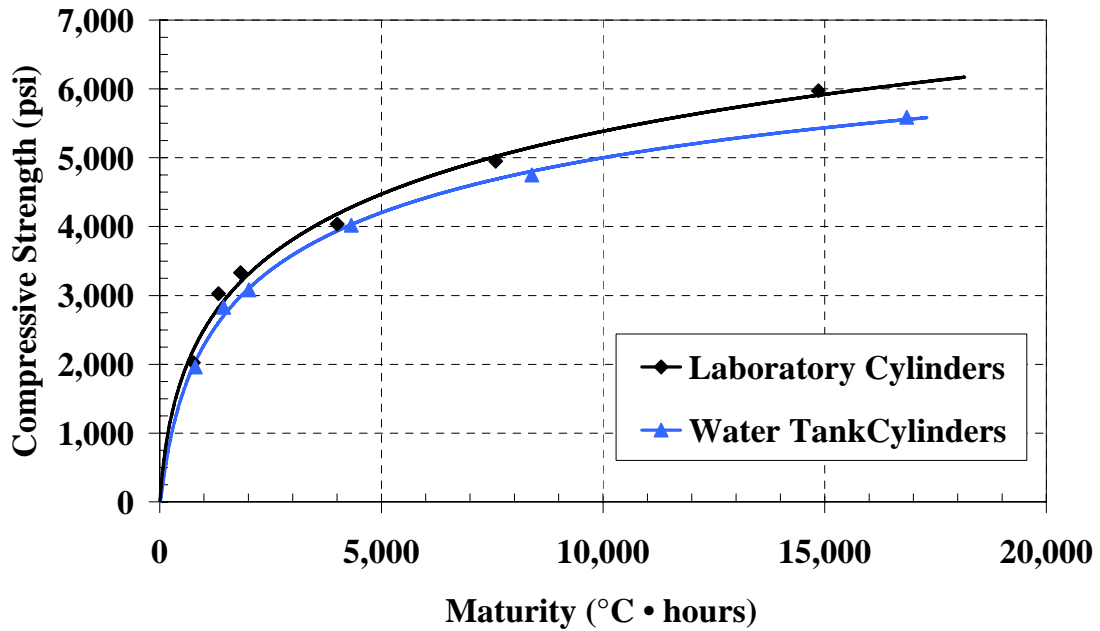

Figure 5-52: S-M relationships using the Nurse-Saul maturity function for mock bridge deck warm-weather placement ($T_0 = 0\text{ }^\circ\text{C}$)

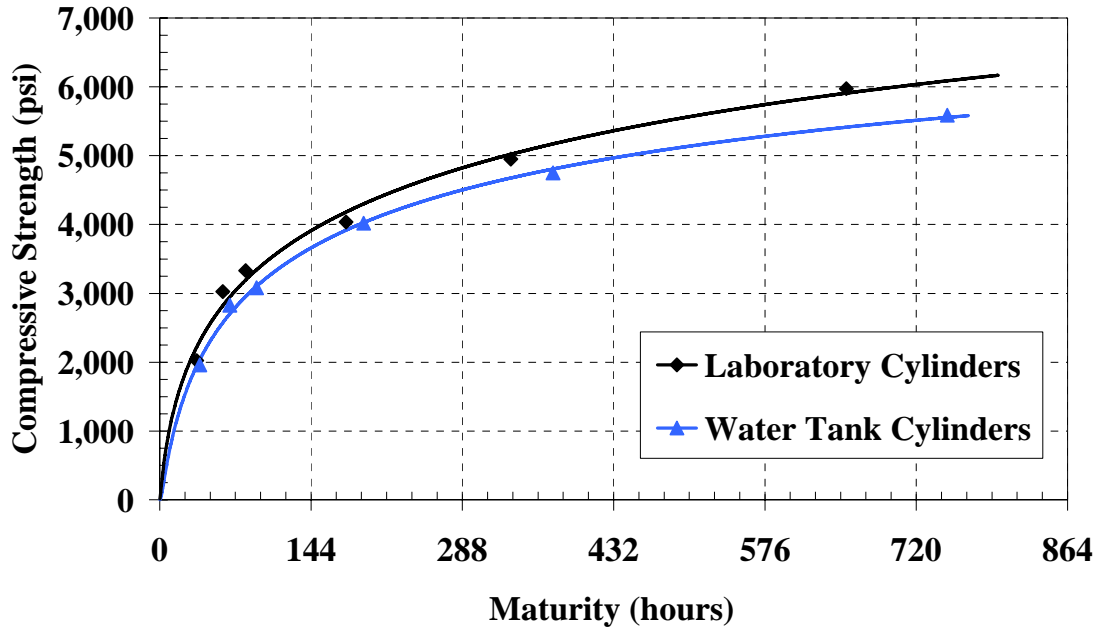

Figure 5-53: S-M relationships using the Arrhenius maturity function for mock bridge deck warm-weather placement ($E = 33.5$ kJ/mol)

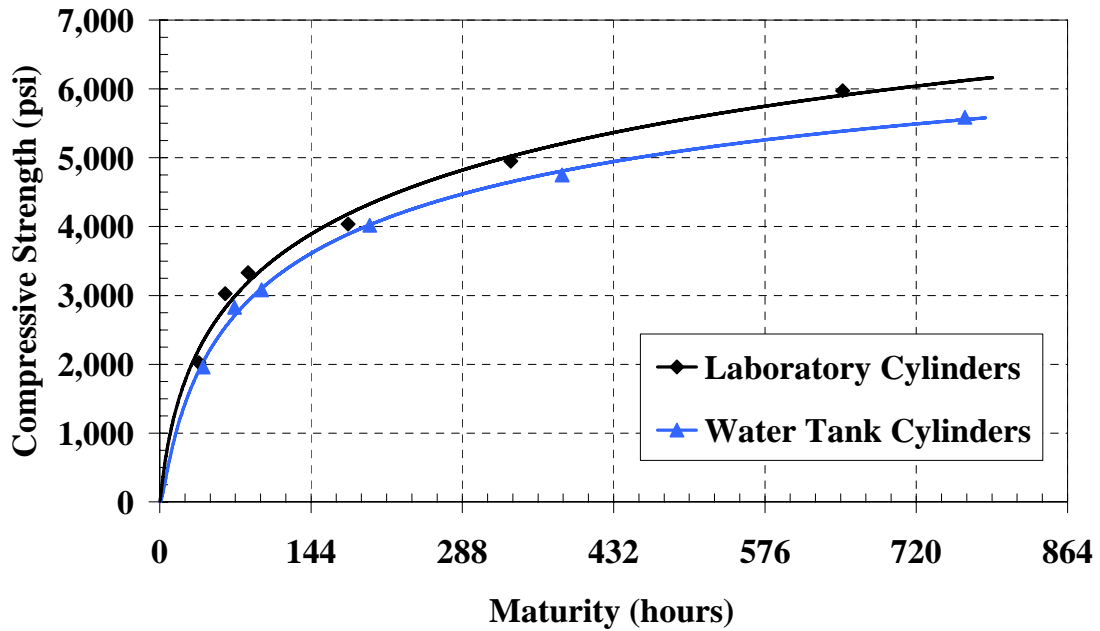

Figure 5-54: S-M relationships using the Arrhenius maturity function for mock bridge deck warm-weather placement ($E = 40$ kJ/mol)

The strength-maturity relationships from the laboratory-cured cylinders with the confidence levels of 50%, 75%, and 90% are presented in Figure 5-55 to 5-58. The confidence levels were calculated as explained in Section 5.5.5.

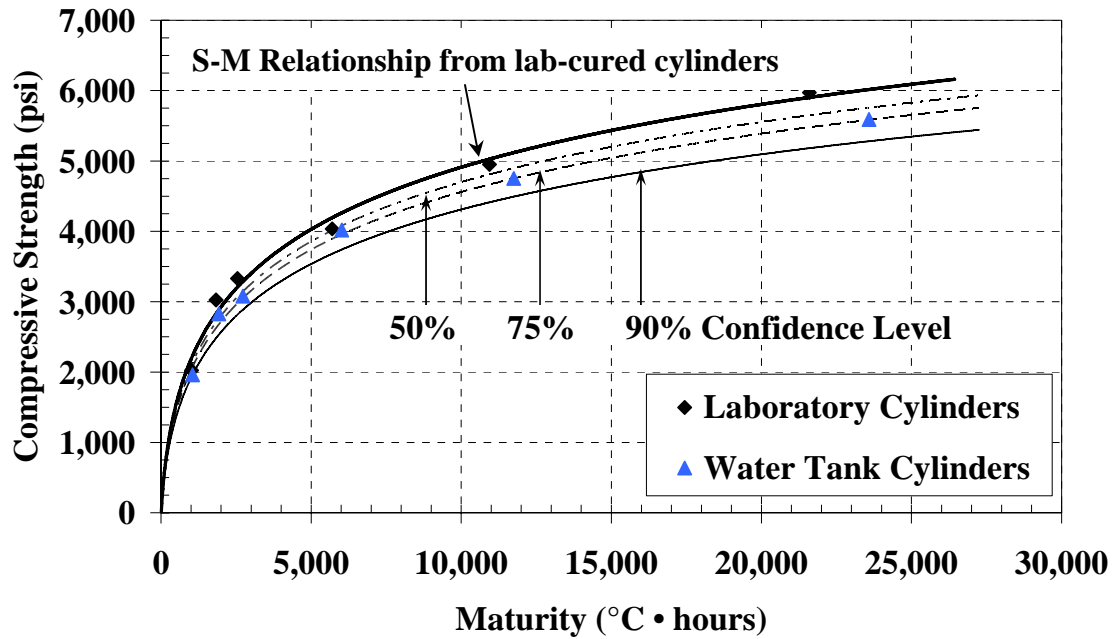

Figure 5-55: S-M relationship for the *Laboratory* cured cylinders with confidence levels for the warm-weather placement of the mock bridge deck ($T_o = -10\text{ }^\circ\text{C}$)

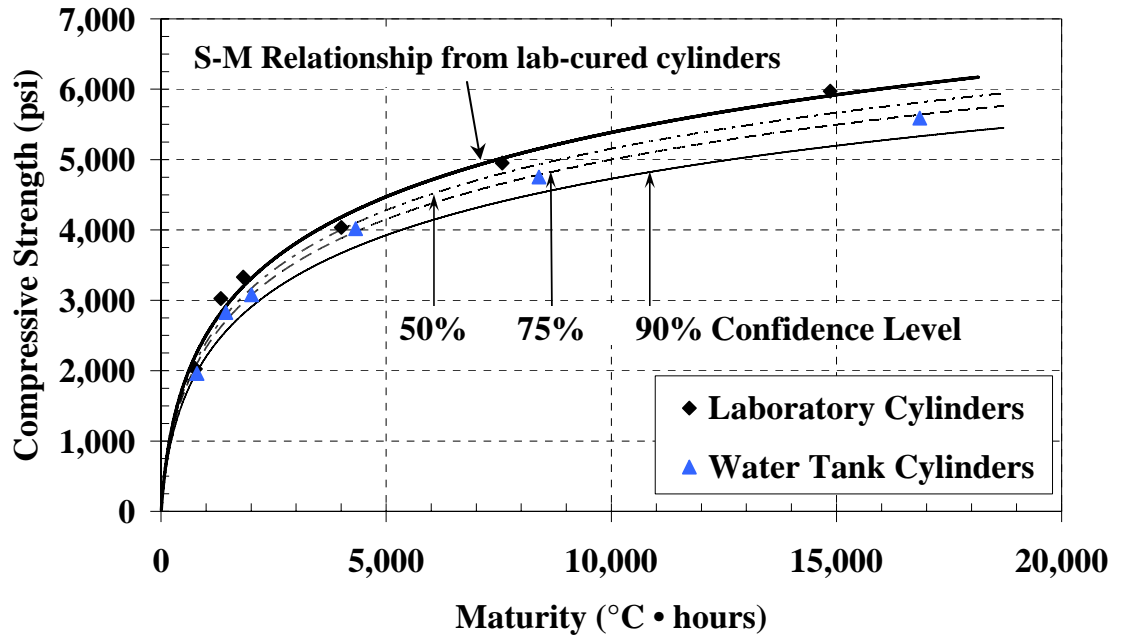

Figure 5-56: S-M relationship for the *Laboratory* cured cylinders with confidence levels for the warm-weather placement of the mock bridge deck ($T_0 = 0^{\circ}\text{C}$)

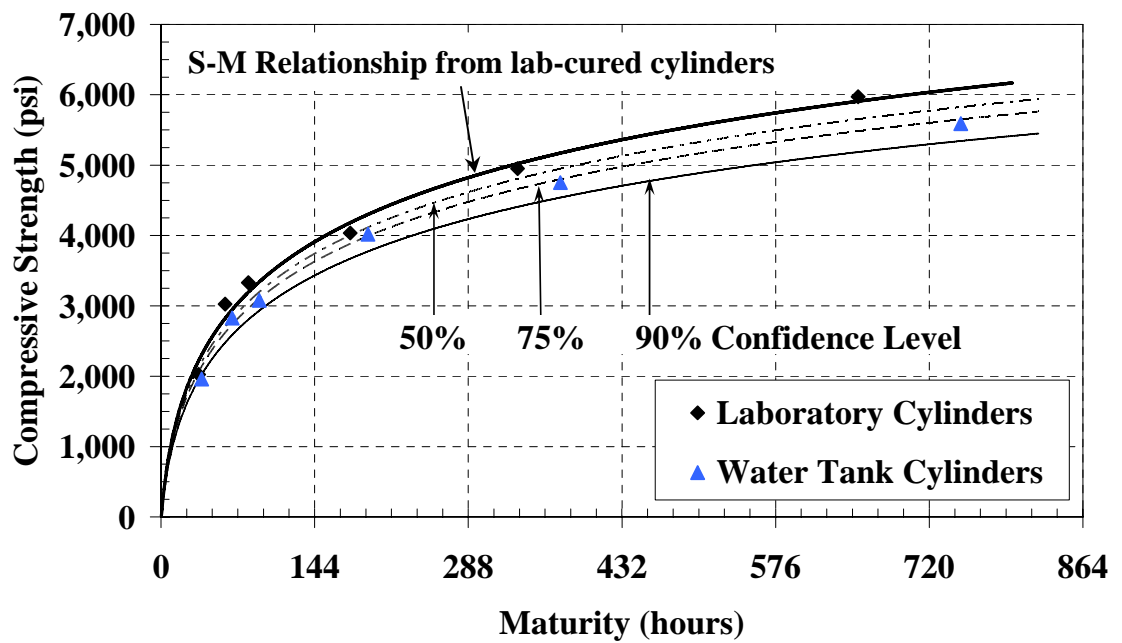

Figure 5-57: S-M relationship for the *Laboratory* cured cylinders with confidence levels for the warm-weather placement of the mock bridge deck ($E = 33.5 \text{ kJ/mol}$)

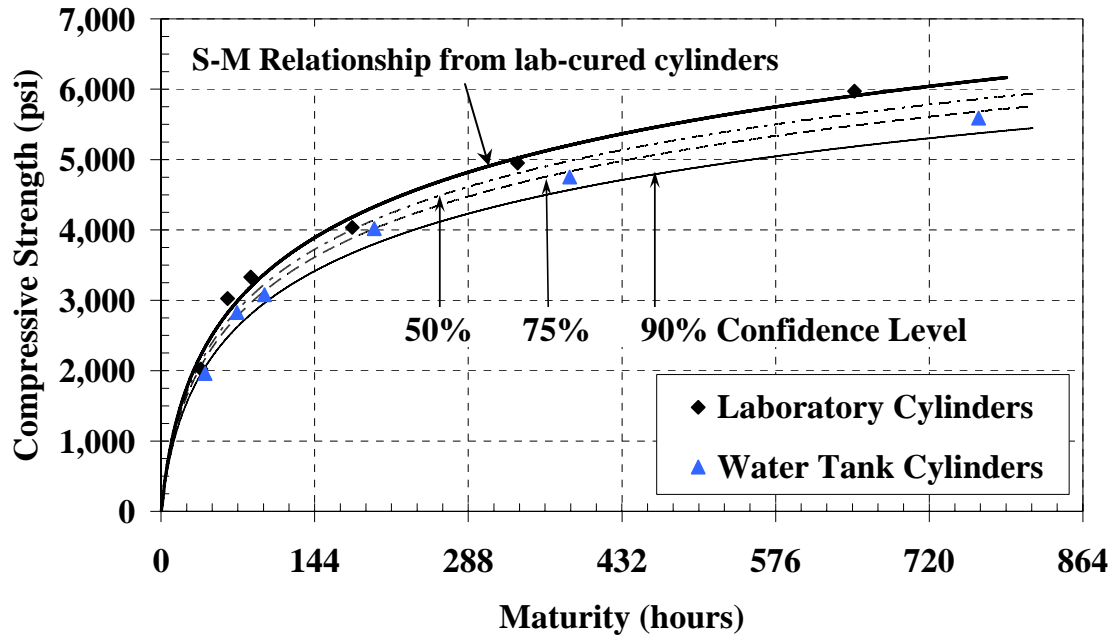

Figure 5-58: S-M relationship for the *Laboratory* cured cylinders with confidence levels for the warm-weather placement of the mock bridge deck ($E = 40$ kJ/mol)

To evaluate whether the water-tank-cured cylinders would better represent the concrete's S-M relationship, the procedure that was used for the laboratory-cured cylinders was used for the water-tank-cured cylinders. The water-tank S-M relationships are presented in Appendix C. The 4 x 8 inch water-tank-cured cylinder data were added with the cast-in-place cylinder data to the laboratory and water-tank S-M relationships because the confidence levels for these were the similar. These graphs are presented in the next section.

5.6.2.5 In-Place Strength Graphs

The strength and maturity data of the in-place tests were graphed with both S-M relationships that were developed for the two different type of cylinder curing. All four

maturities were evaluated: Nurse-Saul maturity function with $T_o = -10\text{ }^\circ\text{C}$ and $0\text{ }^\circ\text{C}$ and Arrhenius maturity function with $E = 33.5\text{ kJ/mol}$ and 40 kJ/mol . Along with the best-fit S-M relationship the confidence levels of 50%, 75%, and 90% were added to the graphs. For Figures 5-59 to 5-70 the Nurse-Saul maturity function with $T_o = 0\text{ }^\circ\text{C}$ and Arrhenius maturity function with $E = 33.5\text{ kJ/mol}$ are presented. The results for the Nurse-Saul maturity function with $T_o = -10\text{ }^\circ\text{C}$ and Arrhenius maturity function with $E = 40\text{ kJ/mol}$ are presented in Appendix C. The laboratory and water-tank S-M relationships with the pullout compressive strengths are presented in Figures 5-59 to 5-62. The laboratory and water-tank cured S-M relationships with the compressive strengths of the cast-in-place cylinder and 4 x 8 inch water-tank-cured cylinders are presented in Figures 5-63 to 5-66. Since the coefficient of variation of the cast-in-place cylinders and 4 x 8 inch water-tank-cured cylinders are similar, the confidence levels for Figures 5-63 to 5-66 were calculated using the coefficients of variation of the 4 x 8 inch molded cylinders. The laboratory and water-tank cured S-M relationships with the compressive strengths of the cores are presented in Figures 5-67 to 5-70.

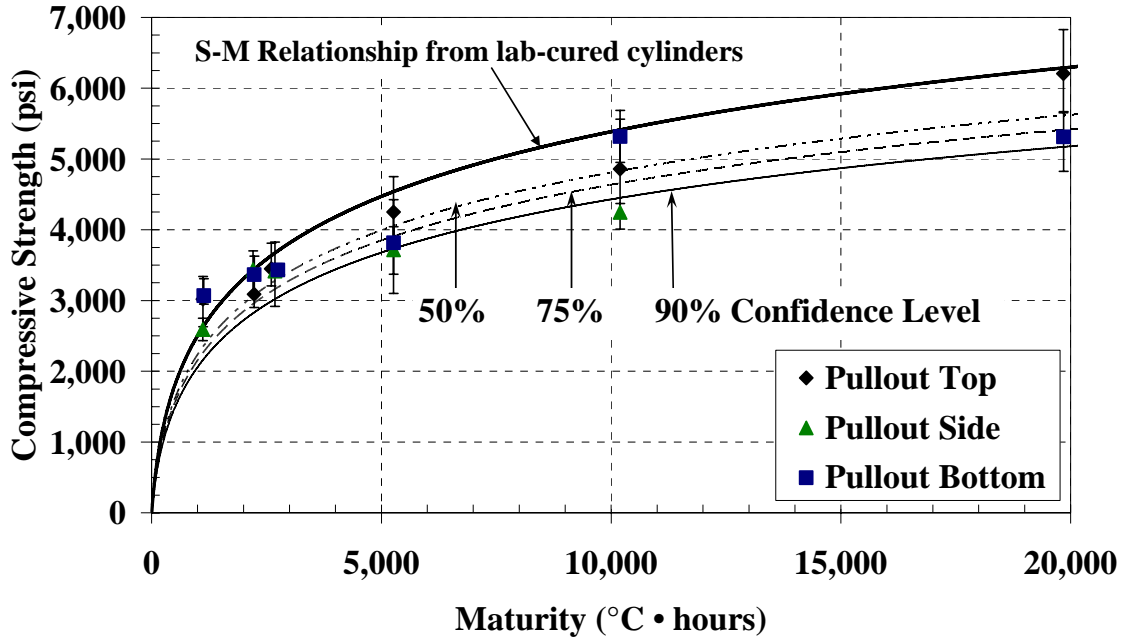

Figure 5-59: Pullout test with *laboratory* S-M relationship and confidence levels for the warm-weather placement of the mock bridge deck ($T_0 = 0^{\circ}\text{C}$)

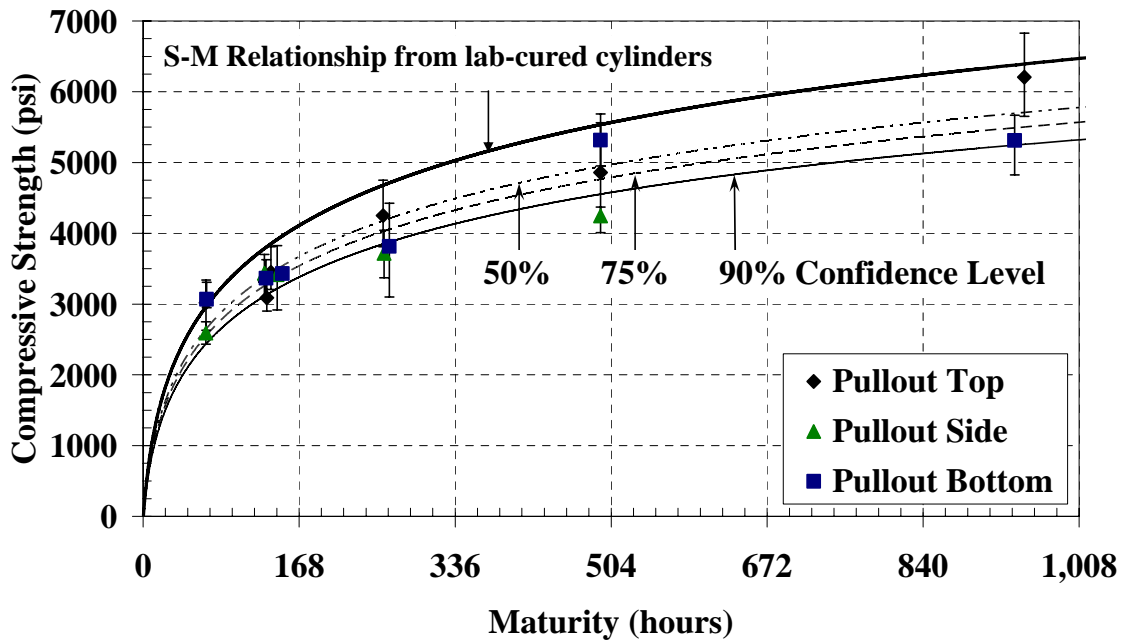

Figure 5-60: Pullout test with *laboratory* S-M relationship and confidence levels for the warm-weather placement of the mock bridge deck ($E = 33.5 \text{ kJ/mol}$)

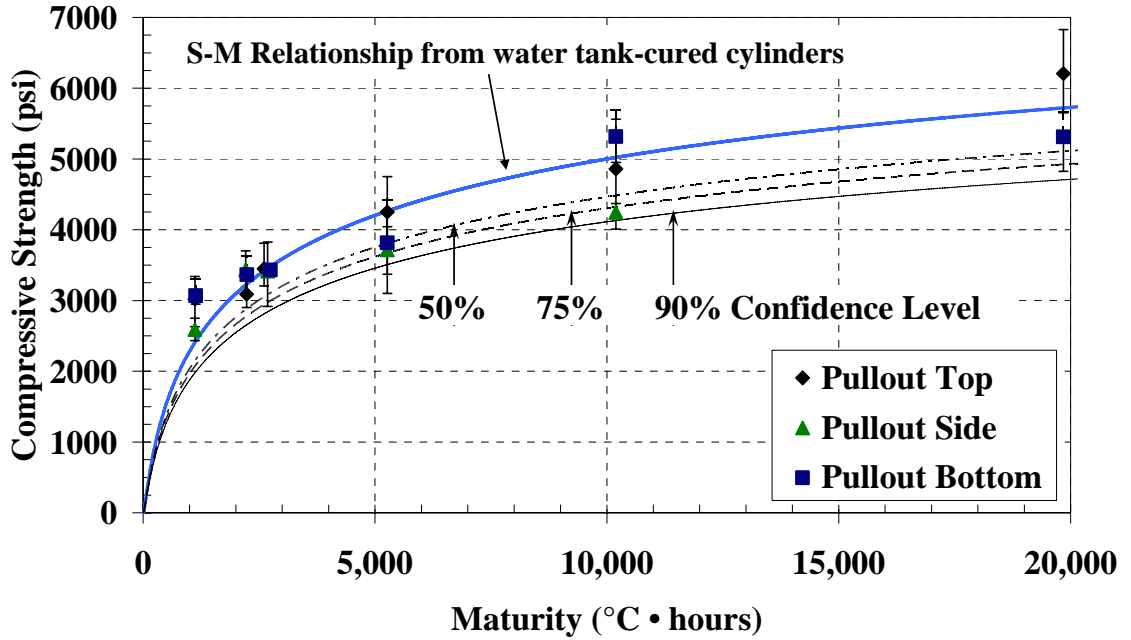

Figure 5-61: Pullout test with *water-tank* S-M relationship and confidence levels for the warm-weather placement of mock bridge deck ($T_o = 0^\circ\text{C}$)

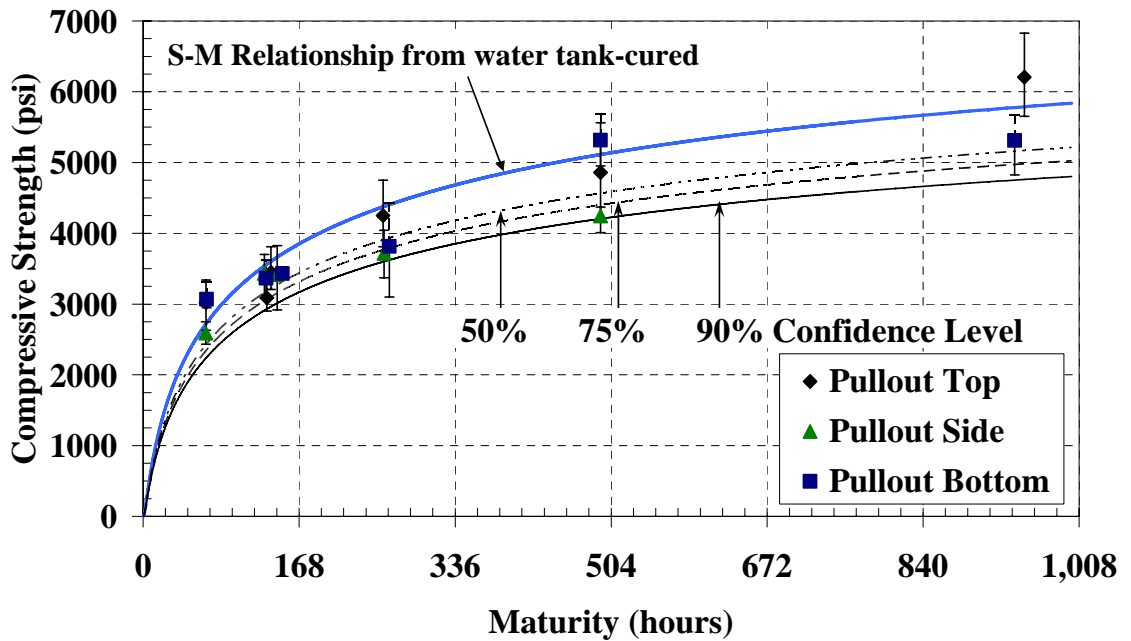

Figure 5-62: Pullout test with *water-tank* S-M relationship and confidence levels for the warm-weather placement of mock bridge deck ($E = 33.5 \text{ kJ/mol}$)

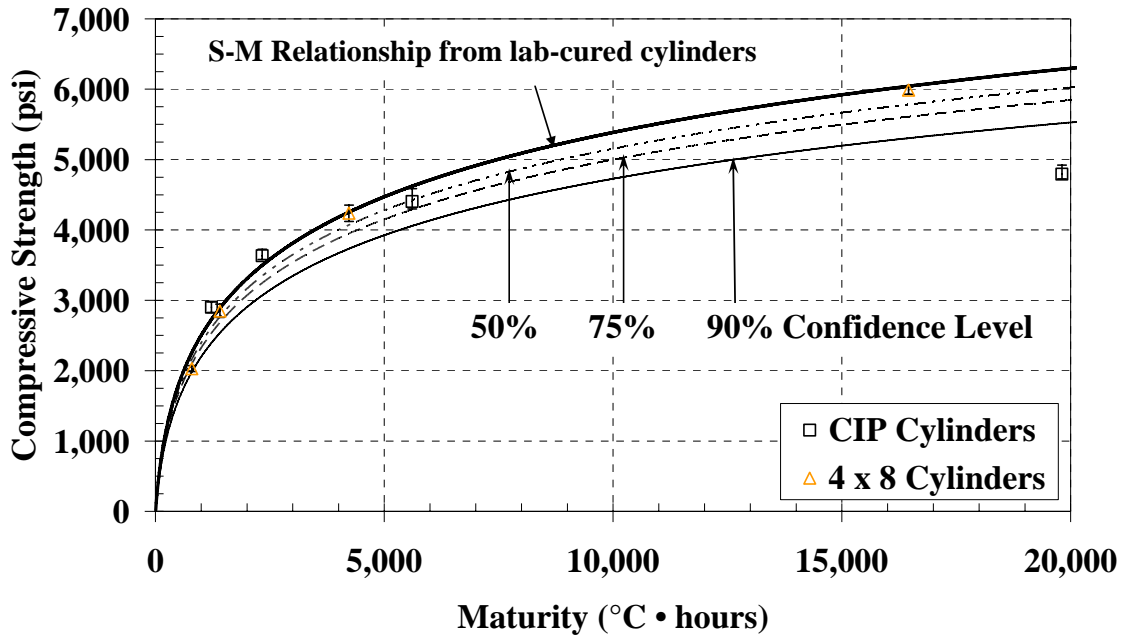

Figure 5-63: Cast-in-place cylinders and 4 x 8 inch cylinders with *laboratory* S-M relationship and confidence levels for the warm-weather placement of the mock bridge deck ($T_o = 0^{\circ}\text{C}$)

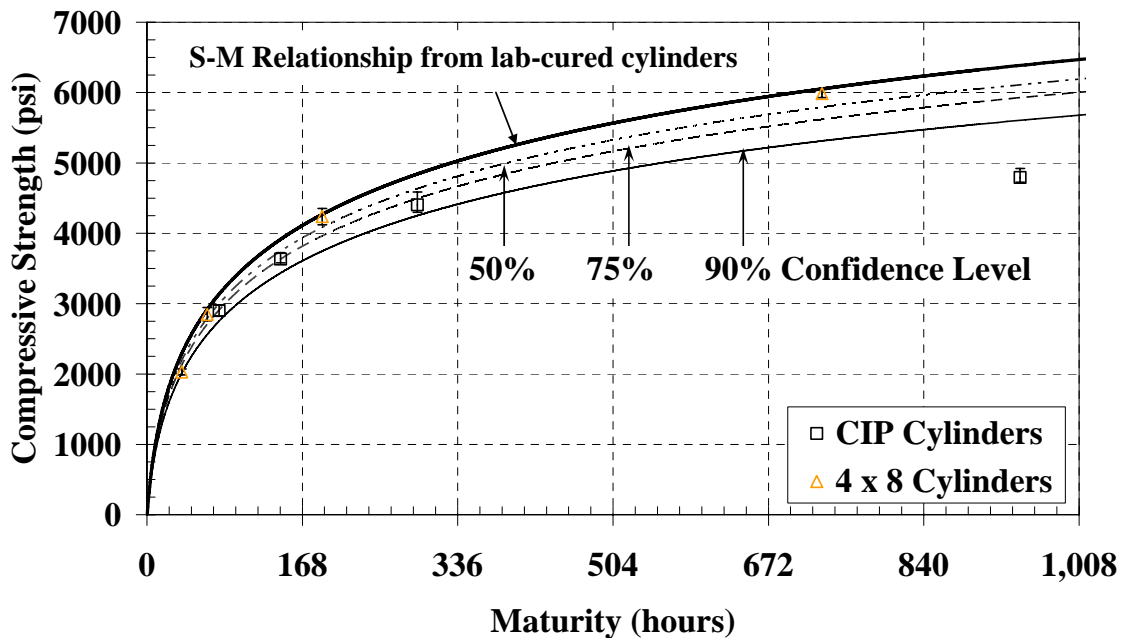

Figure 5-64: Cast-in-place cylinders and 4 x 8 inch cylinders with *laboratory* S-M relationship and confidence levels for the warm-weather placement of the mock bridge deck ($E = 33.5 \text{ kJ/mol}$)

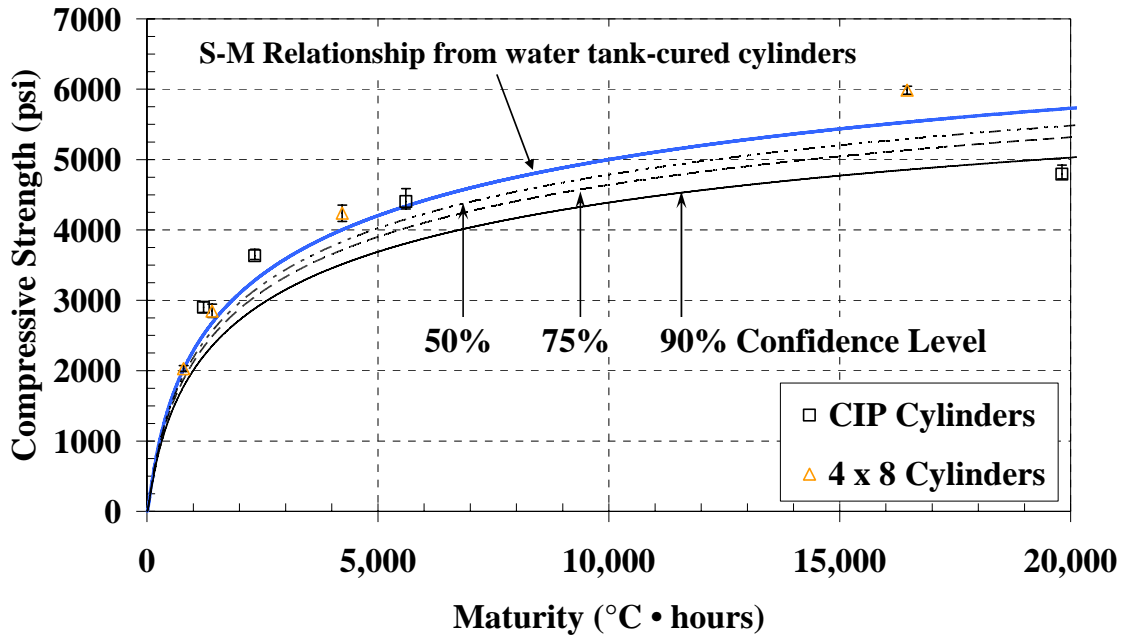

Figure 5-65: Cast-in-place cylinders and 4 x 8 inch cylinders with *water-tank* S-M relationship and confidence levels for the warm-weather placement of mock bridge deck ($T_o = 0^{\circ}\text{C}$)

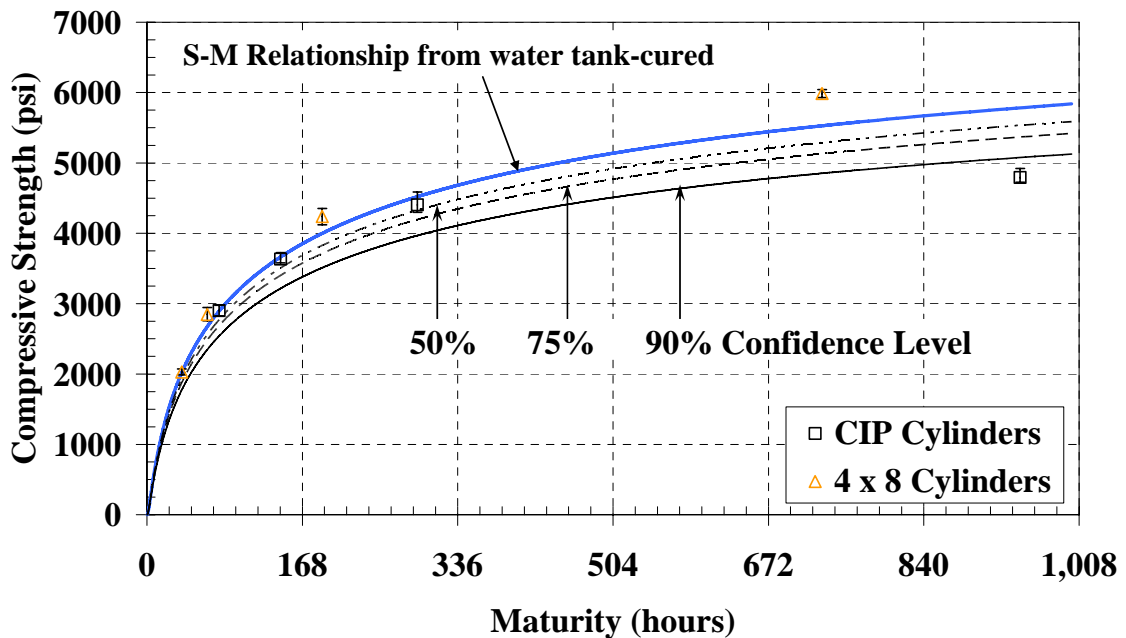

Figure 5-66: Cast-in-place cylinders and 4 x 8 inch cylinders with *water-tank* S-M relationship and confidence levels for the warm-weather placement of mock bridge deck ($E = 33.5 \text{ kJ/mol}$)

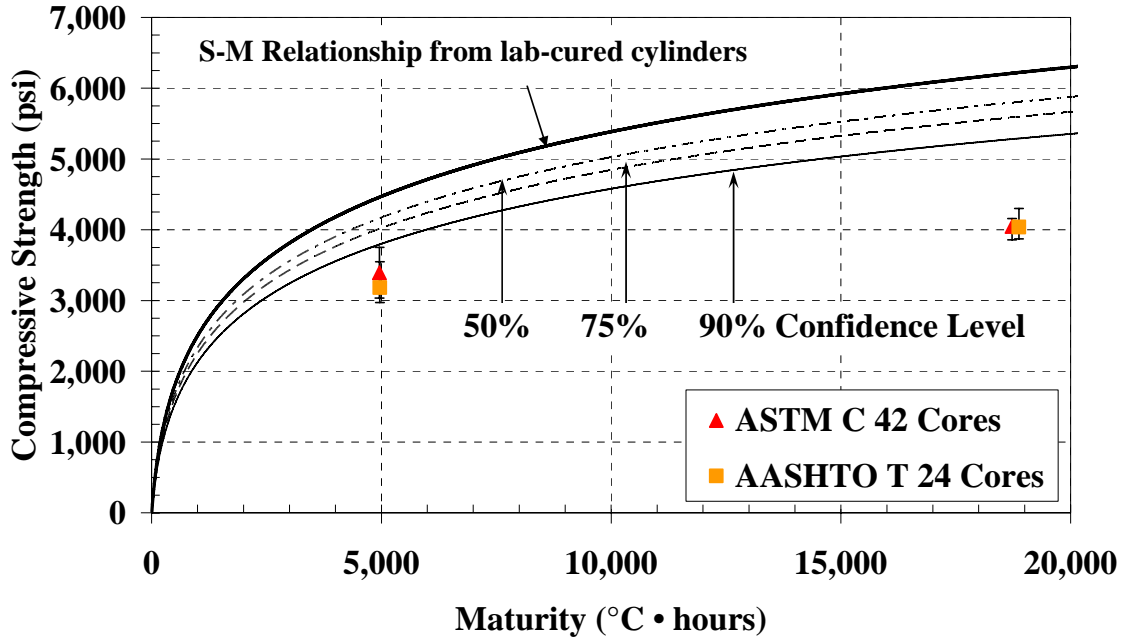

Figure 5-67: Cores with *laboratory* S-M relationship and confidence levels for the warm-weather placement of the mock bridge deck ($T_0 = 0^{\circ}\text{C}$)

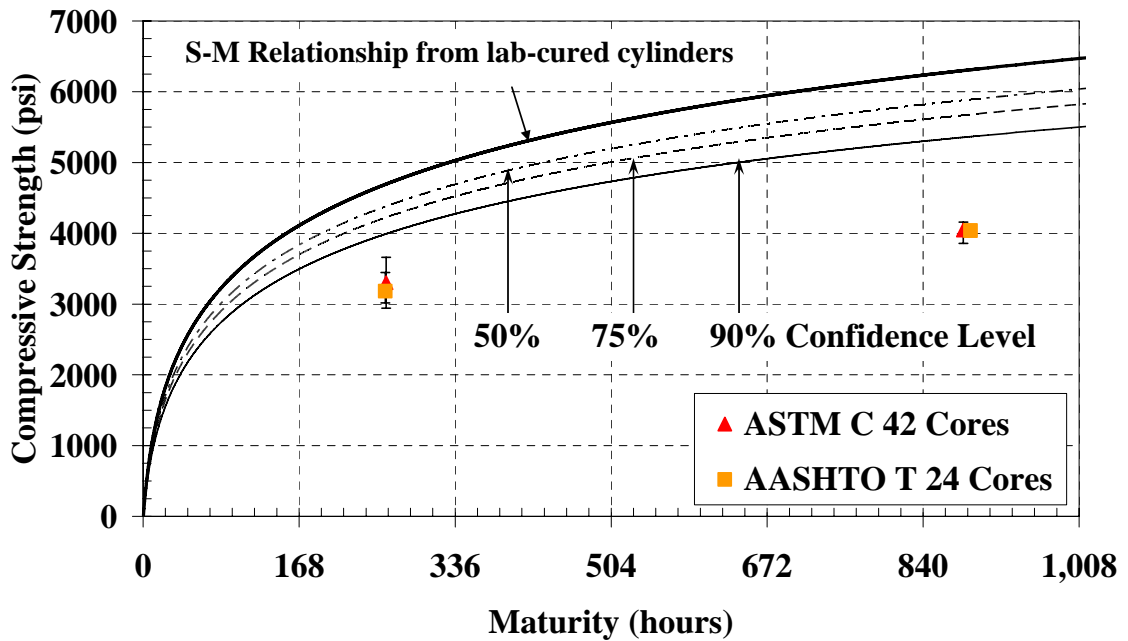

Figure 5-68: Cores with *laboratory* S-M relationship and confidence levels for the warm-weather placement of the mock bridge deck ($E = 33.5 \text{ kJ/mol}$)

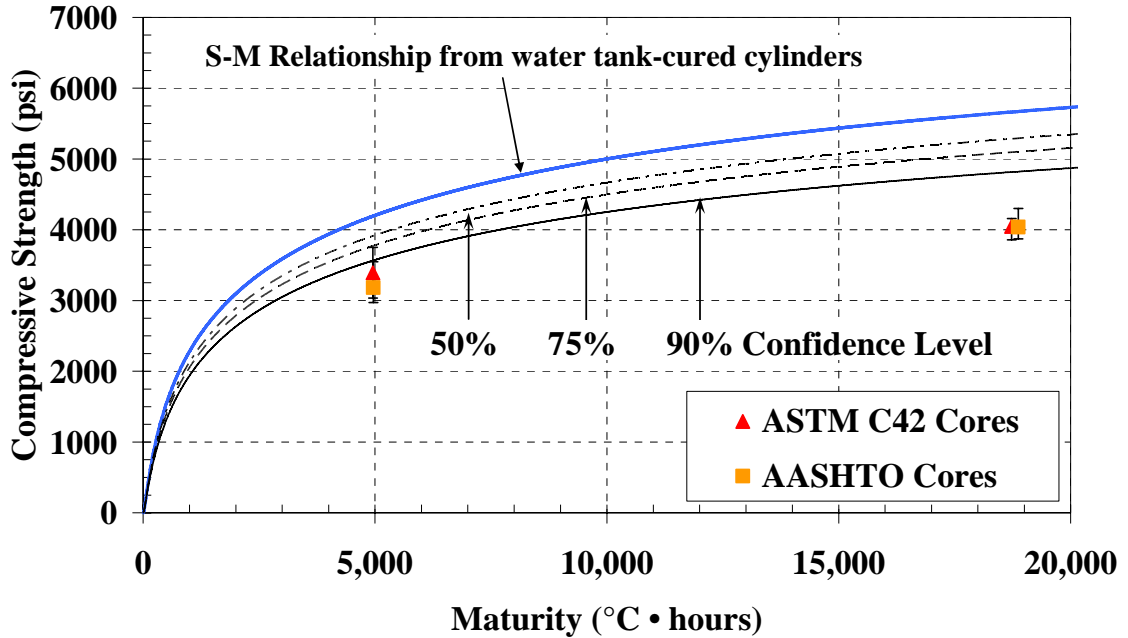

Figure 5-69: Cores with *water-tank* S-M relationship and confidence levels for the warm-weather placement of mock bridge deck ($T_o = 0^{\circ}\text{C}$)

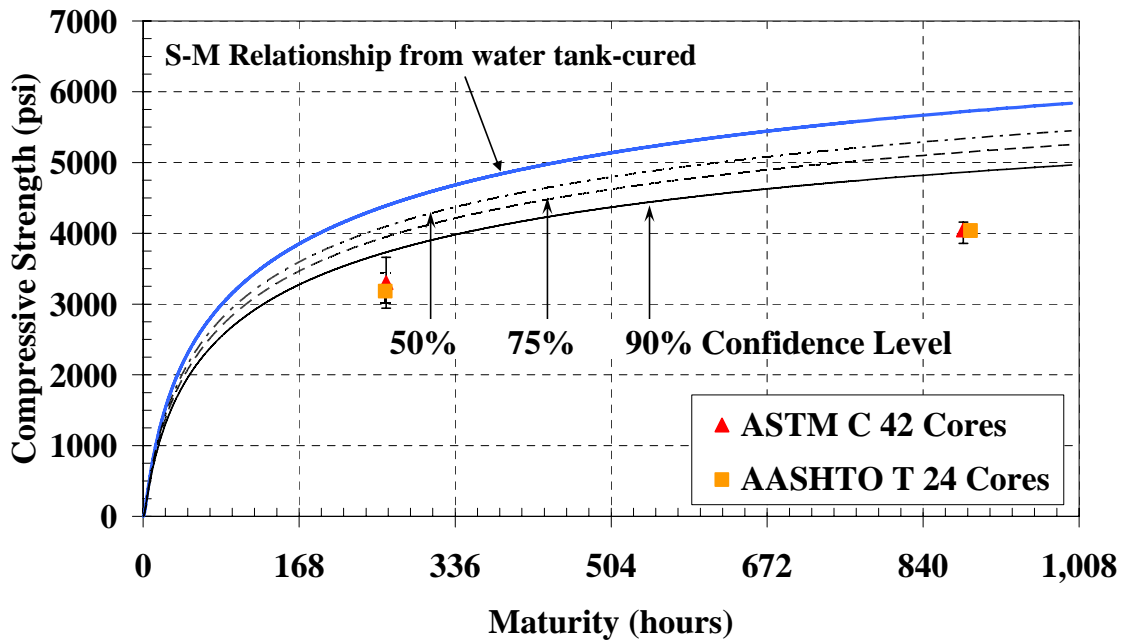

Figure 5-70: Cores with *water-tank* S-M relationship and confidence levels for the warm-weather placement of mock bridge deck ($E = 33.5 \text{ kJ/mol}$)

**5.7 RESULTS FOR THE EVALUATION OF THE USE OF MOLDED
CYLINDERS FOR STRENGTH VERIFICATION TESTING**

All test results for the evaluation of the use of molded cylinders for verification testing are presented in this section. Discussions of the results are presented in Section 5.9 along with tables of errors and graphs that can be used to evaluate the accuracy of the maturity method. As discussed in Section 5.5.1, outliers have already been removed from the data presented in this section. All individual strength test results for this phase are presented in Appendix C. Also, a couple of temperature profiles for the bridge decks are presented in this section, and all temperatures profiles are presented in Appendix C. Table 5-26 provides the test location notation that is used to identify the different S-M relationships and verification tests. Refer back to Figure 5-7 and 5-8 for the actual locations of the verification tests.

Table 5-26: Notation for the different testing locations on the two bridge decks

Bridge and Temperature Sensor Location	Test Location Notation
I-85 Bridge: Location 2	I-85 A
I-85 Bridge: Location 4	I-85 B
I-85 Bridge: Location 5	I-85 C
I-85 Bridge: Location 8	I-85 D
Creek Bridge: Location 1	Creek C
Creek Bridge: Location 3	Creek B
Creek Bridge: Location 5	Creek A

5.7.2 FRESH CONCRETE PROPERTIES

Fresh concrete properties were determined for the concrete delivered to the construction site by an ALDOT inspector. However, the air content was not taken for all the samples. Table 5-15 summarizes the fresh concrete properties for each location where cylinders were required for the S-M relationship or verification testing.

Table 5-27: Fresh concrete properties for evaluation of the use of molded cylinders for verification testing

Test Location	Batch Date and Time	Fresh Concrete Properties	Results
I-85 A	12/21/04 10:15 AM	Air (%)	-
		Slump (in.)	3.75
		Temperature (°F)	62
I-85 B	12/21/04 8:20 AM	Air (%)	1.0%
		Slump (in.)	2
		Temperature (°F)	58
I-85 C	1/5/05 12:08 PM	Air (%)	4.0%
		Slump (in.)	4
		Temperature (°F)	69
I-85 D	1/5/05 7:33 AM	Air (%)	3.5%
		Slump (in.)	5
		Temperature (°F)	69
Creek A	4/4/05 1:20 PM	Air (%)	-
		Slump (in.)	3.75
		Temperature (°F)	-
Creek B	4/4/05 3:00 PM	Air (%)	3.8%
		Slump (in.)	4
		Temperature (°F)	74
Creek C	4/4/05 5:40 PM	Air (%)	4.0%
		Slump (in.)	3
		Temperature (°F)	76

5.7.3 TEMPERATURE DATA

The temperature histories of all of the molded cylinders are presented in this section along with some of the temperature histories of the bridge decks. The temperature histories from the laboratory-cured I-85 Bridge cylinders and the bridge deck where the concrete was sampled are presented in Figures 5-71 to 5-74. Ambient temperatures were also added. The first 8 days are shown to illustrate the initial heat development; for the remainder of time, the concrete temperature fluctuated with the change in ambient temperatures. The temperature histories from all the laboratory-cured Creek Bridge cylinders and the bridge deck where the concrete was sampled are presented in Figures 5-75 to 5-77. Ambient temperatures are also shown, and only the first 8 days of data is presented.

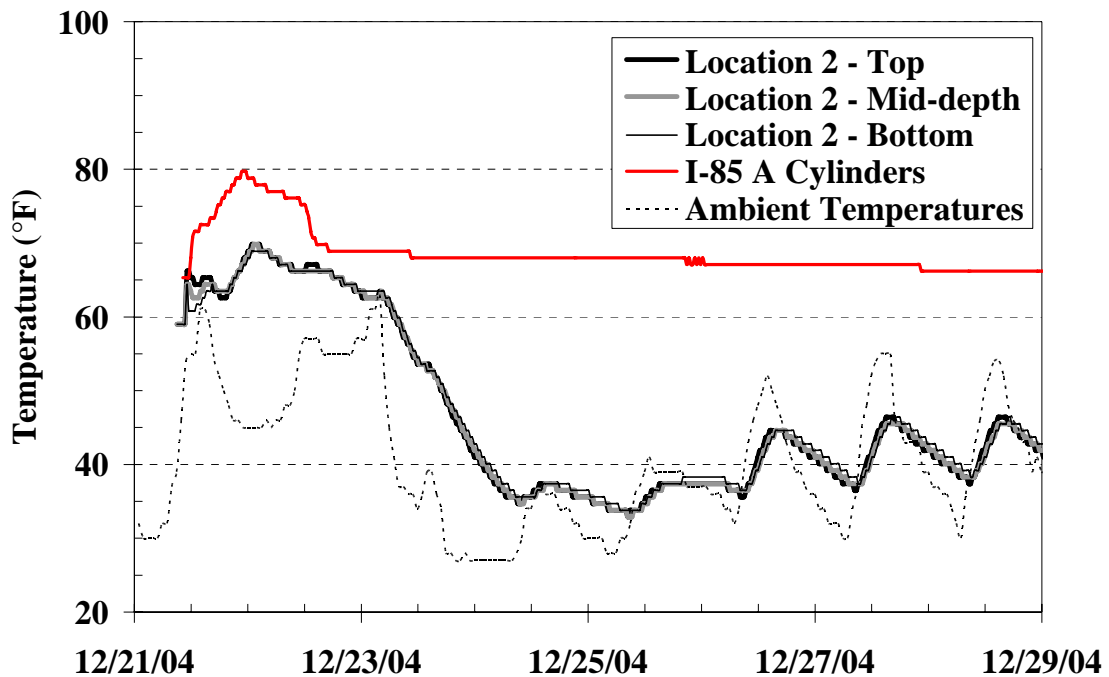

Figure 5-71: Temperature history of I-85 Sample A with corresponding bridge deck temperatures

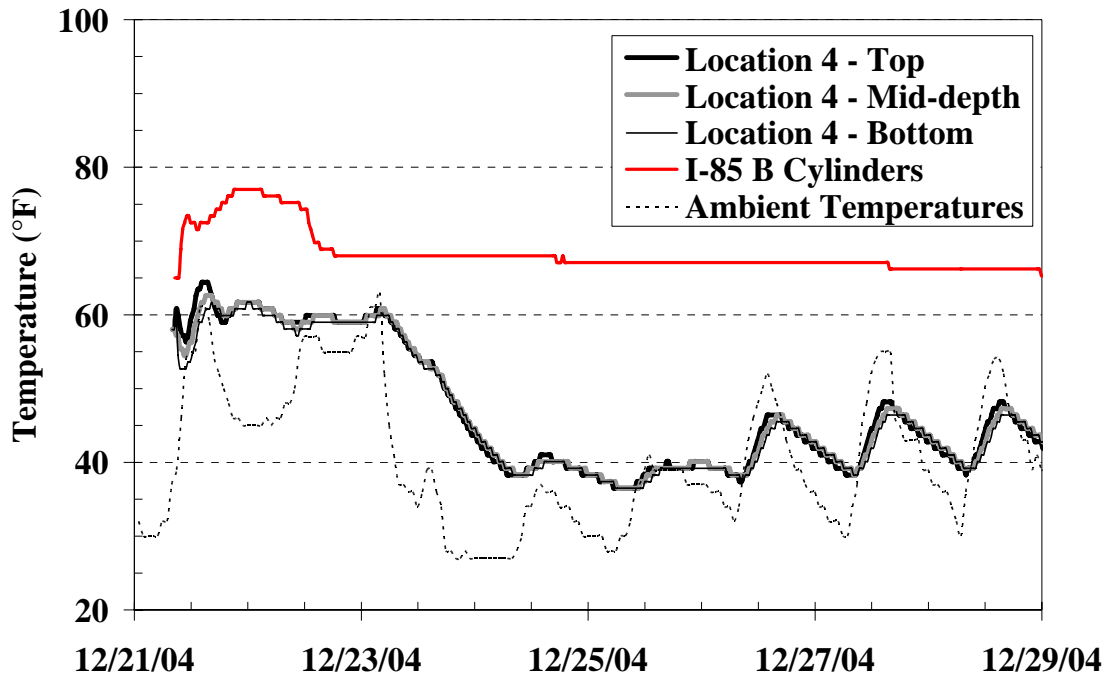

Figure 5-72: Temperature history of I-85 Sample B with corresponding bridge deck temperatures

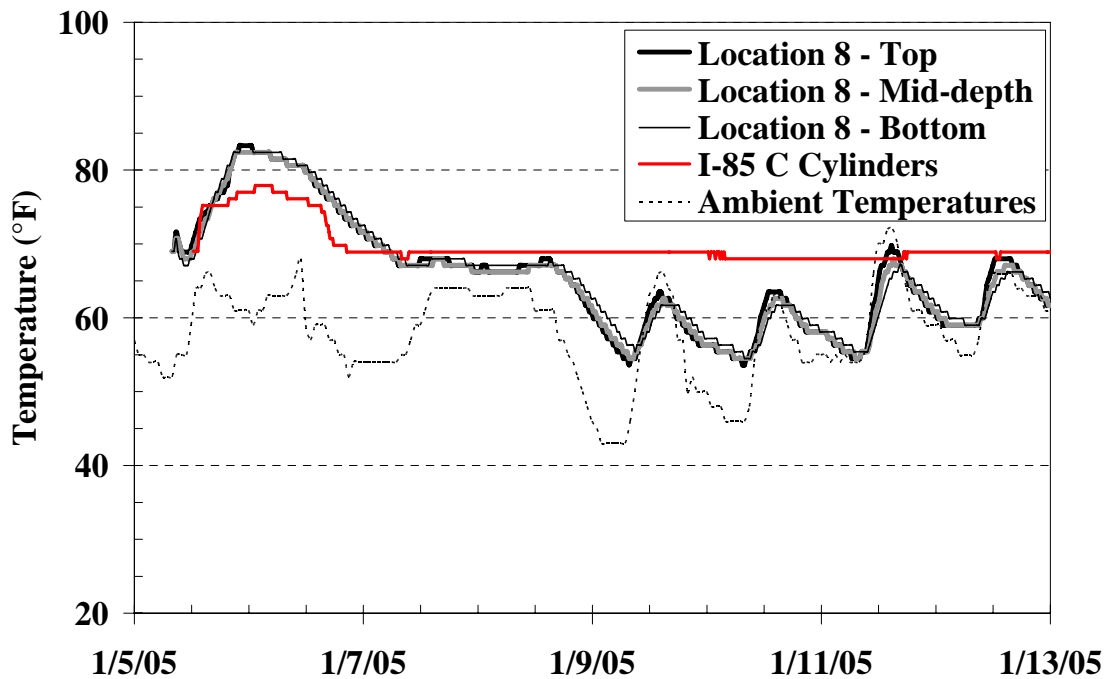

Figure 5-73: Temperature history of I-85 Sample C with corresponding bridge deck temperatures

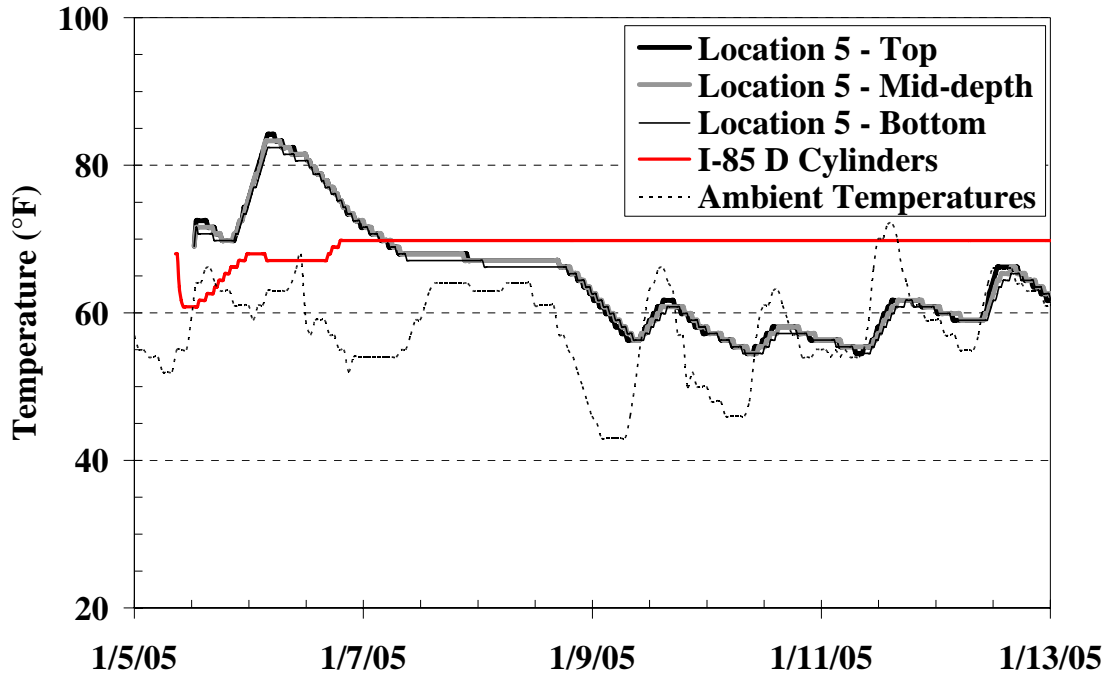

Figure 5-74: Temperature history of I-85 Sample D with corresponding bridge deck temperatures

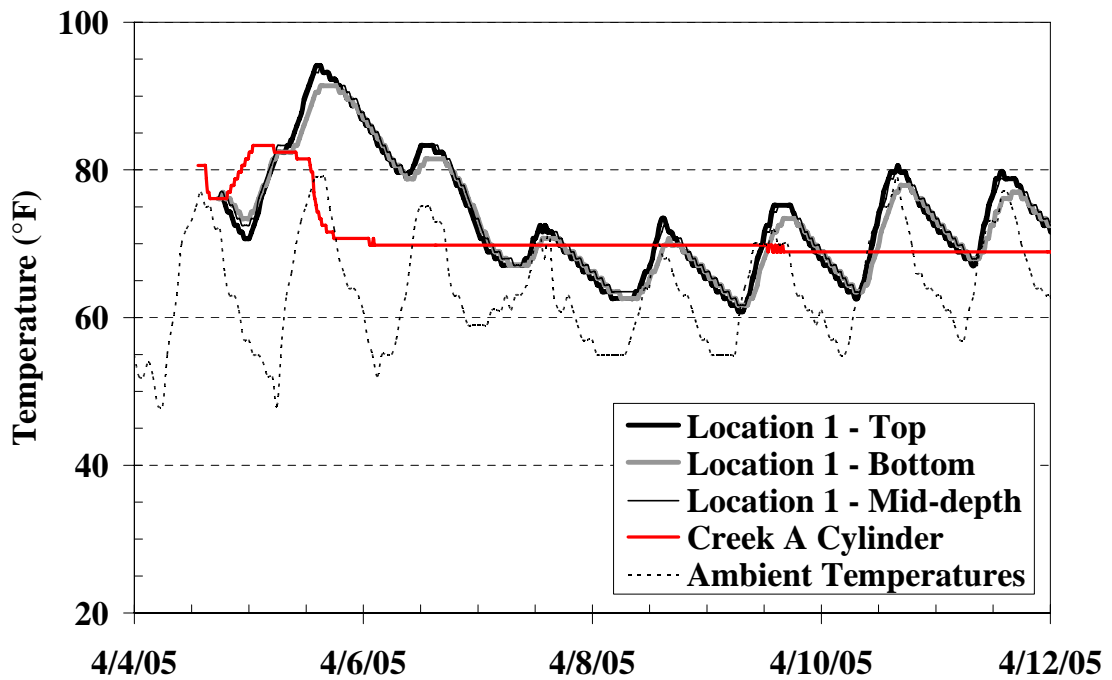

Figure 5-75: Temperature history of Creek Bridge Sample A with corresponding bridge deck temperatures

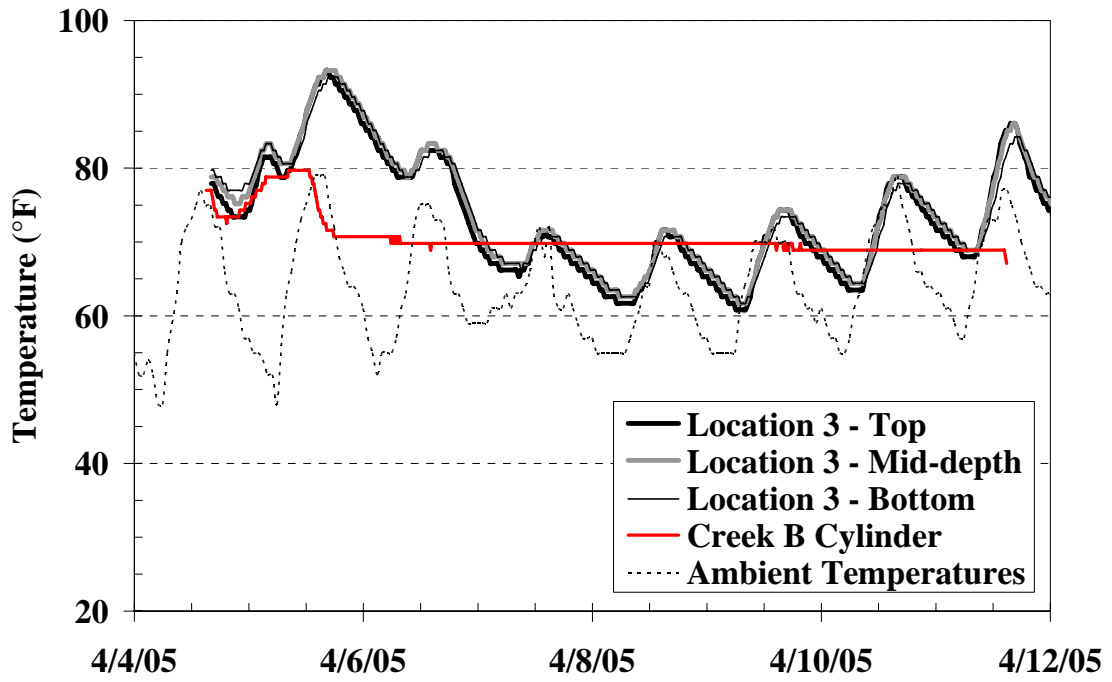

Figure 5-76: Temperature history of Creek Bridge Sample B with corresponding bridge deck temperatures

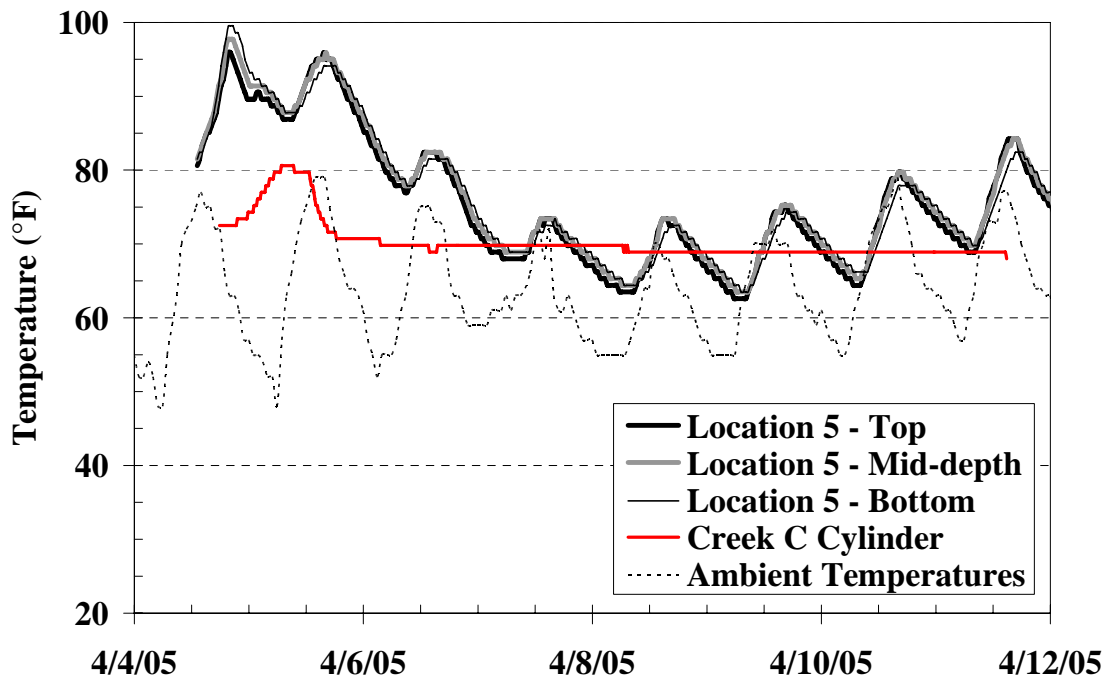

Figure 5-77: Temperature history of Creek Bridge Sample C with corresponding bridge deck temperatures

The final temperature histories that are presented in this section are additional temperatures recorded from the I-85 and Creek Bridge decks. The difference between the top, mid-depth, and bottom temperature histories can be seen in the Figures 5-71 to 5-77. The difference between the center of the bridge deck and outside edge of the bridge deck can be seen in Figure 5-78 which shows Location 1 and 2 of the Creek Bridge. Location 2 is the center of the bridge deck. Presented in Figure 5-79 are the results of Location 6 of the I-85 Bridge where one set of sensors was attached to the reinforcement and the other set of sensors was suspended away from the reinforcement. The location labeled 6S is the temperature sensors that were attached to the reinforcement steel and the location labeled 6 was suspended away from the steel as explained in Section 5.4.4.

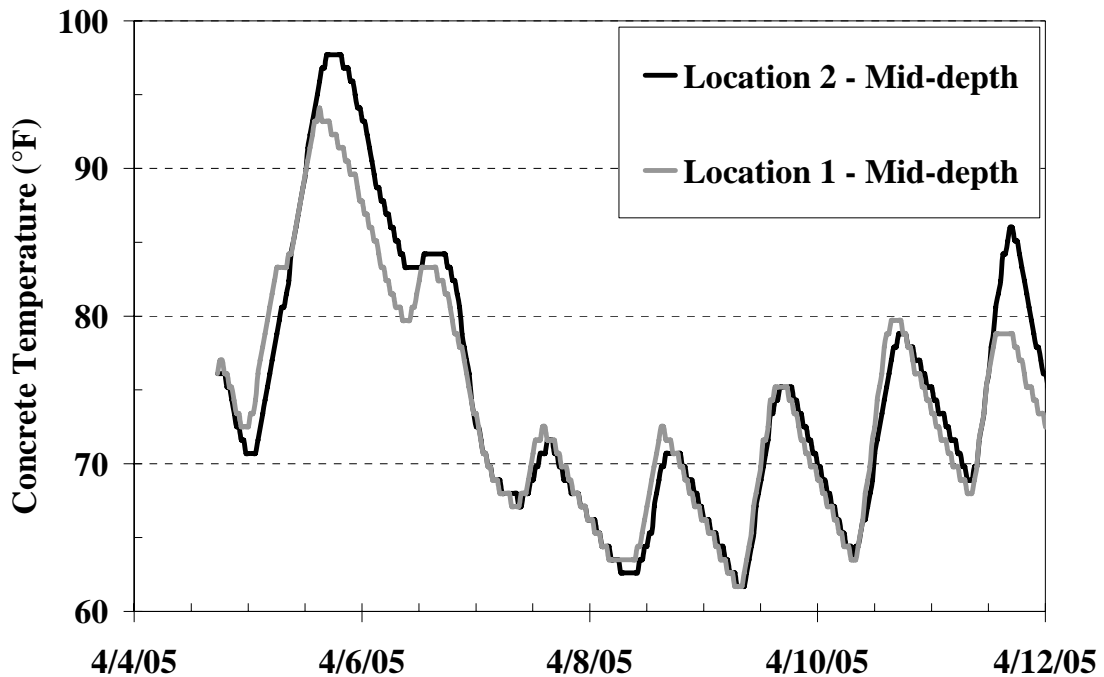

Figure 5-78: Temperature history of Location 1 (Mid-depth) and Location 2 (Mid-depth) from the Creek Bridge deck

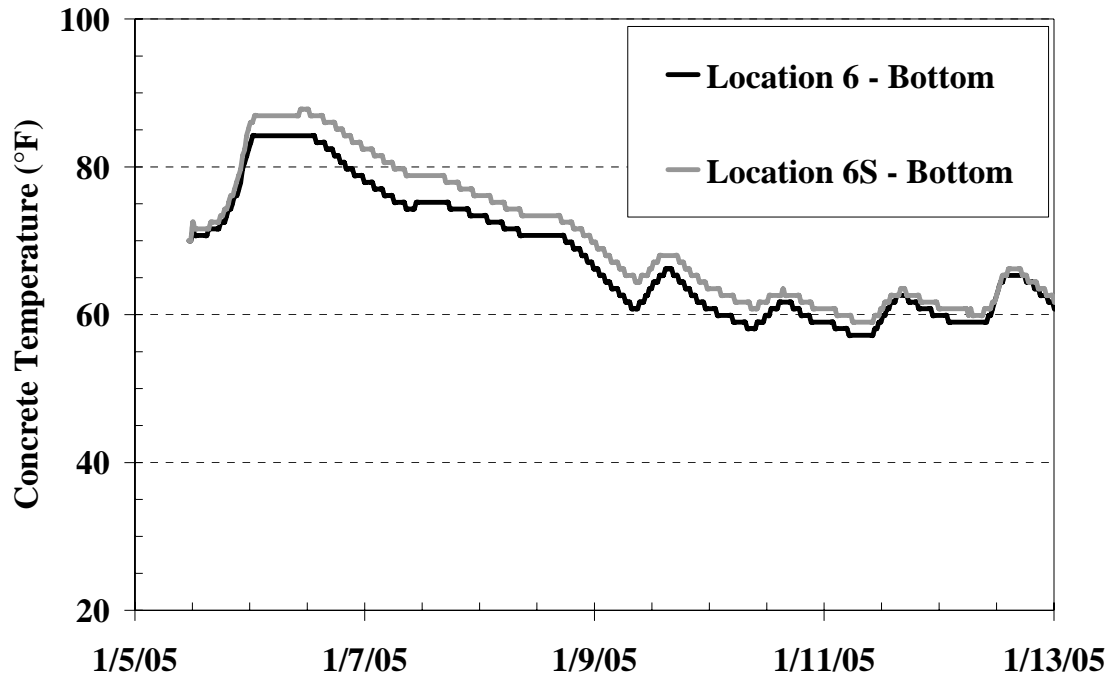

Figure 5-79: Temperature history of Location 6 (Bottom) and Location 6S (Bottom) from the I-85 Bridge

5.7.4 STRENGTH DATA

The maturity values and strength test results for the I-85 Bridge and Creek bridge specimens used to develop the S-M relationships are summarized in Table 5-28 and 5-29. No outliers were removed from the data set, but the 3-day testing for the Creek Bridge was removed because of complications that occurred during testing. The verification test, maturity values, and strength test results are presented in Table 5-30. No outliers were removed from the verification test results.

Table 5-28: I-85 Bridge Sample D cylinders strength and maturity data

Target Age (days)	Concrete Age (hours)	Nurse-Saul Maturity (°C • hours)		Arrhenius Maturity (hours)		Measured Strength (psi)
		T _o = -10 °C	T _o = 0 °C	E = 33.5 kJ/mol	E = 40 kJ/mol	
1	24.0	681	441	19.6	18.8	1,000
2	47.9	1,402	925	40.8	39.6	2,220
3	77.0	2,306	1,537	67.7	66.0	3,000
4	103.5	3,109	2,078	91.4	89.3	3,520
7	172.1	5,206	3,487	153.3	149.9	4,060
14	339.8	10,314	6,920	303.9	297.5	4,820
28	680.6	20,429	13,735	603.4	589.6	5,770

Table 5-29: Creek Bridge Sample A cylinders strength and maturity data

Target Age (days)	Concrete Age (hours)	Nurse-Saul Maturity (°C • hours)		Arrhenius Maturity (hours)		Measured Strength (psi)
		T _o = -10 °C	T _o = 0 °C	E = 33.5 kJ/mol	E = 40 kJ/mol	
1	24.6	906	661	30.8	30.8	1,840
2	48.5	1,652	1,170	52.9	52.9	2,860
3	-	-	-	-	-	-
4	93.7	3,055	2,120	93.9	93.9	3,610
7	168.9	5,333	3,676	160.9	160.9	4,090
14	333.0	10,415	7,087	307.9	307.9	4,950
28	668.3	20,896	14,214	616.1	616.1	5,910

Table 5-30: Verification test cylinders strength and maturity data

Cylinder Set	Testing Target	Nurse-Saul Maturity (°C • hours)		Arrhenius Maturity (hours)		Measured Strength (psi)
		T _o = -10 °C	T _o = 0 °C	E = 33.5 kJ/mol	E = 40 kJ/mol	
I-85 A	2,400 psi	1,063	747	33.0	33.3	1,740
	7 Day	5,135	3,452	149.1	152.0	3,600
I-85 B	2,400 psi	1,084	757	33.4	33.5	1,570
	7 Day	5,143	3,445	151.7	148.5	3,580
I-85 C	2,400 psi	1,444	1,007	44.4	44.5	2,050
	7 Day	5,183	3,513	154.4	152.2	3,530
Creek B	2,400 psi	1,571	1,097	48.4	48.7	2,800
	7 Day	5,268	3,595	157.9	156.3	4,360
Creek C	2,400 psi	1,568	1,091	48.2	48.1	2,390
	7 Day	5,170	3,518	152.7	154.6	3,690

5.7.5 STRENGTH-MATURITY (S-M) RELATIONSHIPS

The strength-maturity relationships for the two bridge decks were developed as stated in Section 5.5.3. The best-fit S_u , β , and τ values and R^2 values are summarized in Appendix C. The S-M relationship using the Nurse-Saul maturity function with $T_o = -10$ °C is shown in Figure 5-80. The S-M relationship using the Nurse-Saul maturity function with $T_o = 0$ °C is shown in Figure 5-81. The S-M relationship using the Arrhenius maturity function with $E = 33,500$ J/mol is shown in Figure 5-82. The S-M relationship using the Arrhenius maturity function with $E = 40,000$ J/mol is shown in Figure 5-83.

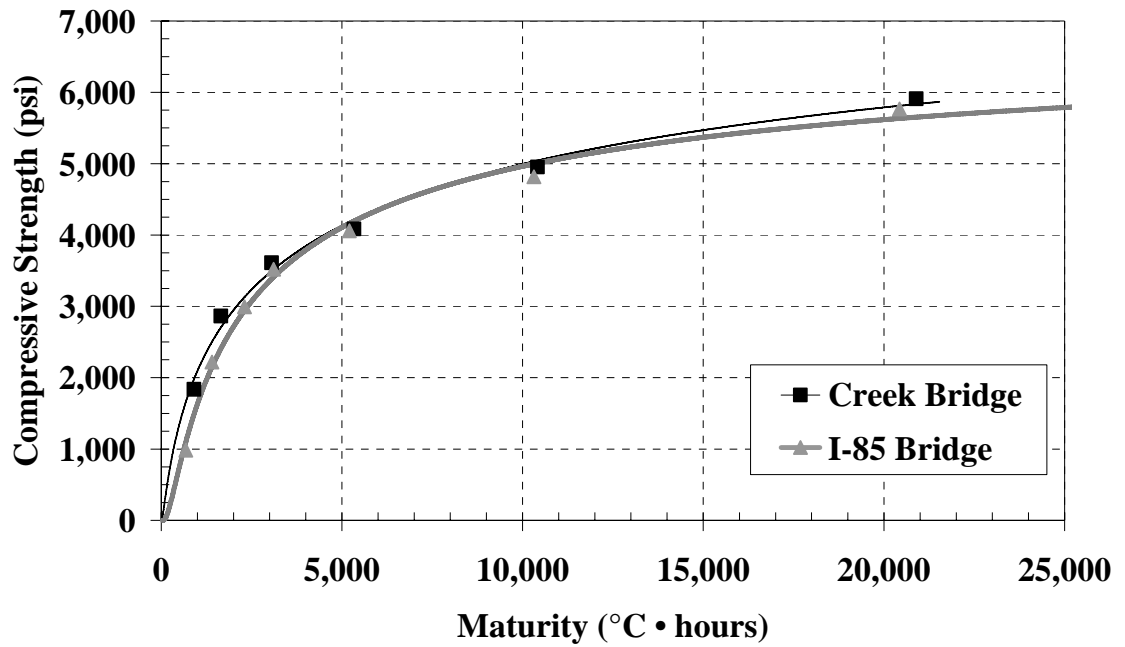

Figure 5-80: The S-M relationship using the Nurse-Saul maturity function for I-85 and Creek Bridge decks ($T_0 = -10\text{ }^\circ\text{C}$)

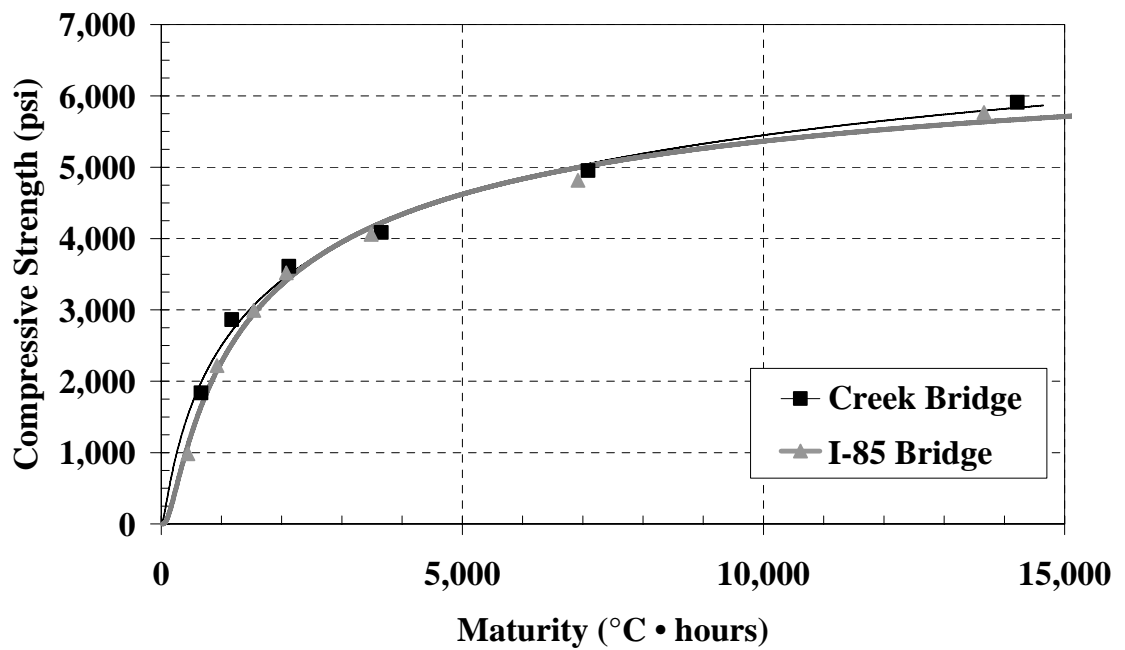

Figure 5-81: The S-M relationship using the Nurse-Saul maturity function for I-85 and Creek Bridge decks ($T_0 = 0\text{ }^\circ\text{C}$)

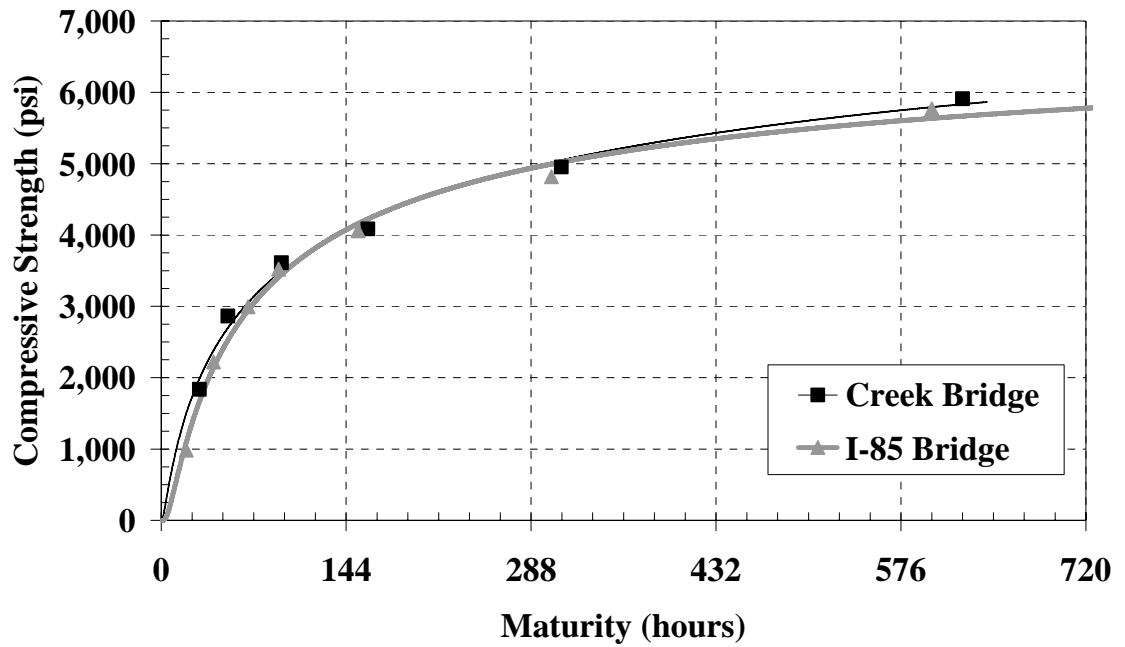

Figure 5-82: The S-M relationship using the Arrhenius maturity function for I-85 and Creek Bridge decks ($E = 33.5$ kJ/mol)

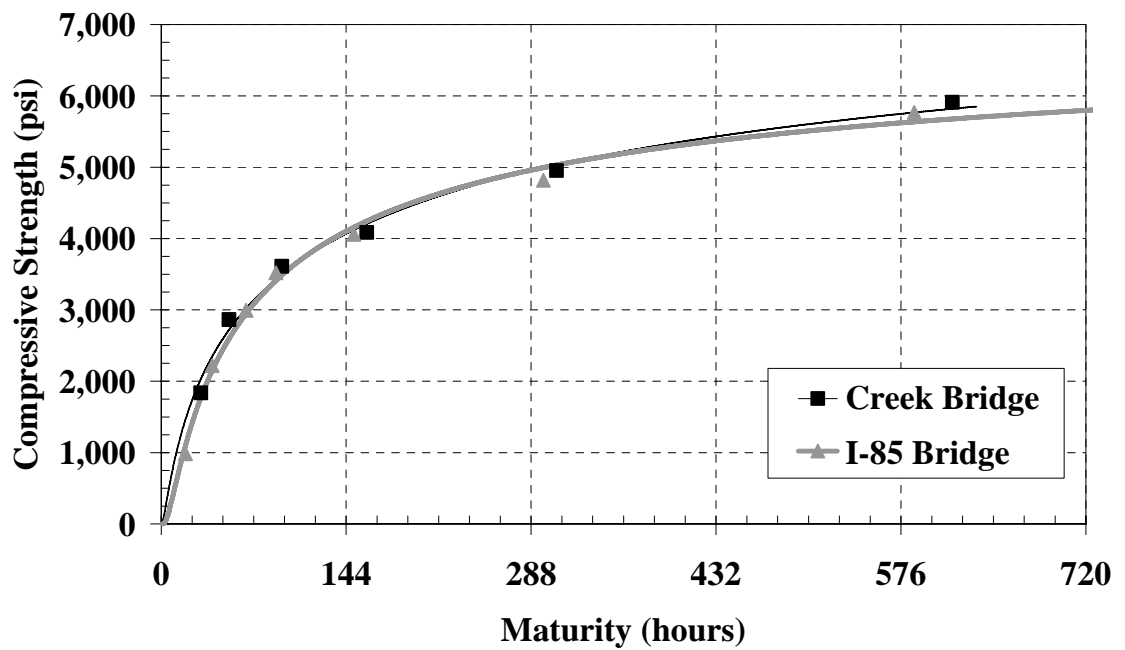

Figure 5-83: The S-M relationship using the Arrhenius maturity function for I-85 and Creek Bridge decks ($E = 40$ kJ/mol)

Since the I-85 Bridge S-M relationship was the first one developed for the concrete being placed in the bridge decks, this S-M relationship was used for all verification tests for the entire project. This procedure was used because this would be similar to the actual procedures used when implementing the maturity method on the construction site. The S-M relationships included confidence levels of 50%, 75%, and 90%, and the verification test results are shown on Figures 5-84 to 5-87. The estimated strength at various confidence levels were calculated as explained in Section 5.5.5.

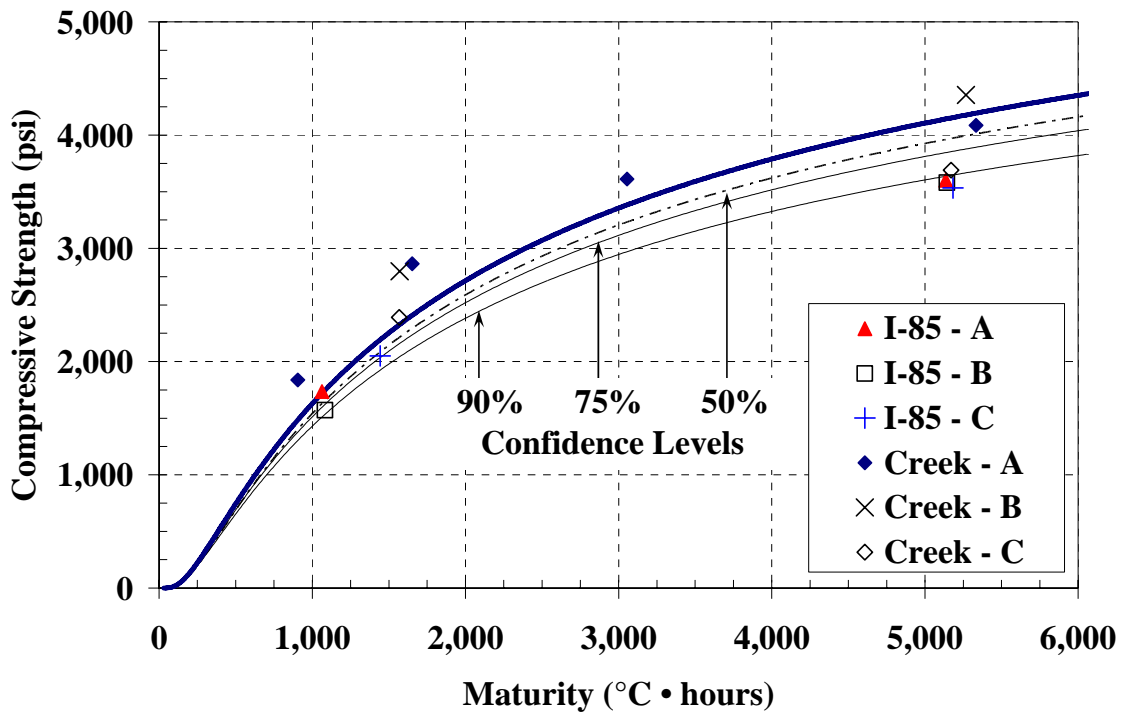

Figure 5-84: I-85 Bridge S-M relationship with confidence levels and verification test results ($T_o = -10\text{ }^\circ\text{C}$)

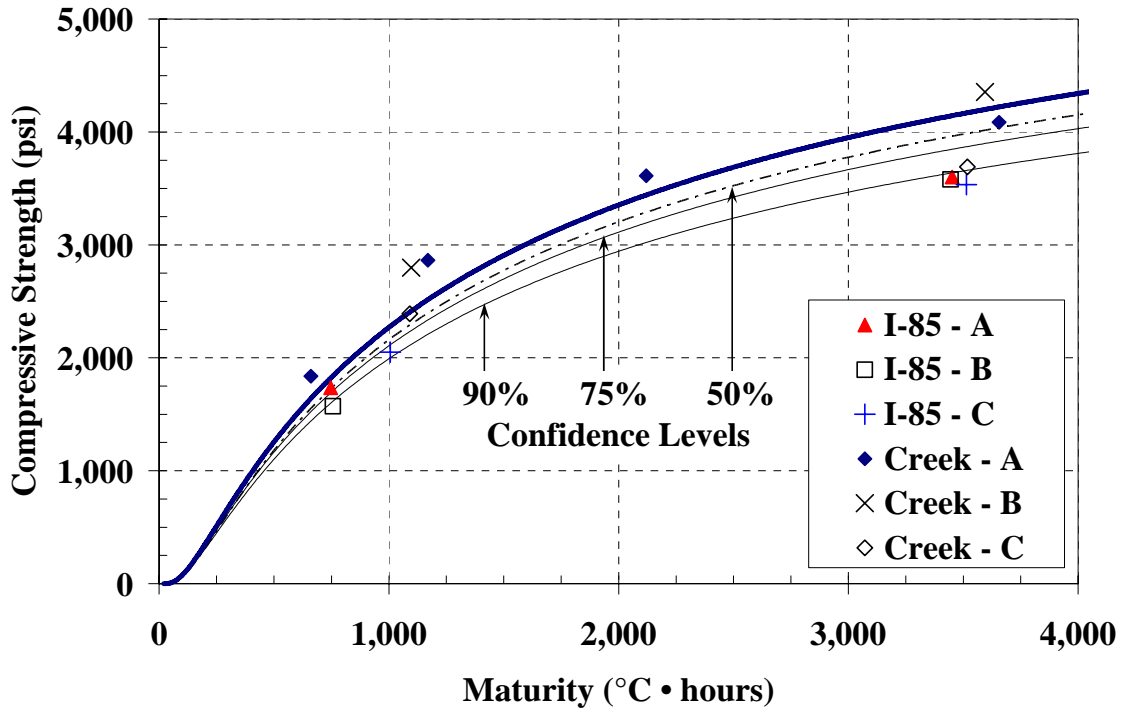

Figure 5-85: I-85 Bridge S-M relationship with confidence levels and verification test results ($T_0 = 0^{\circ}\text{C}$)

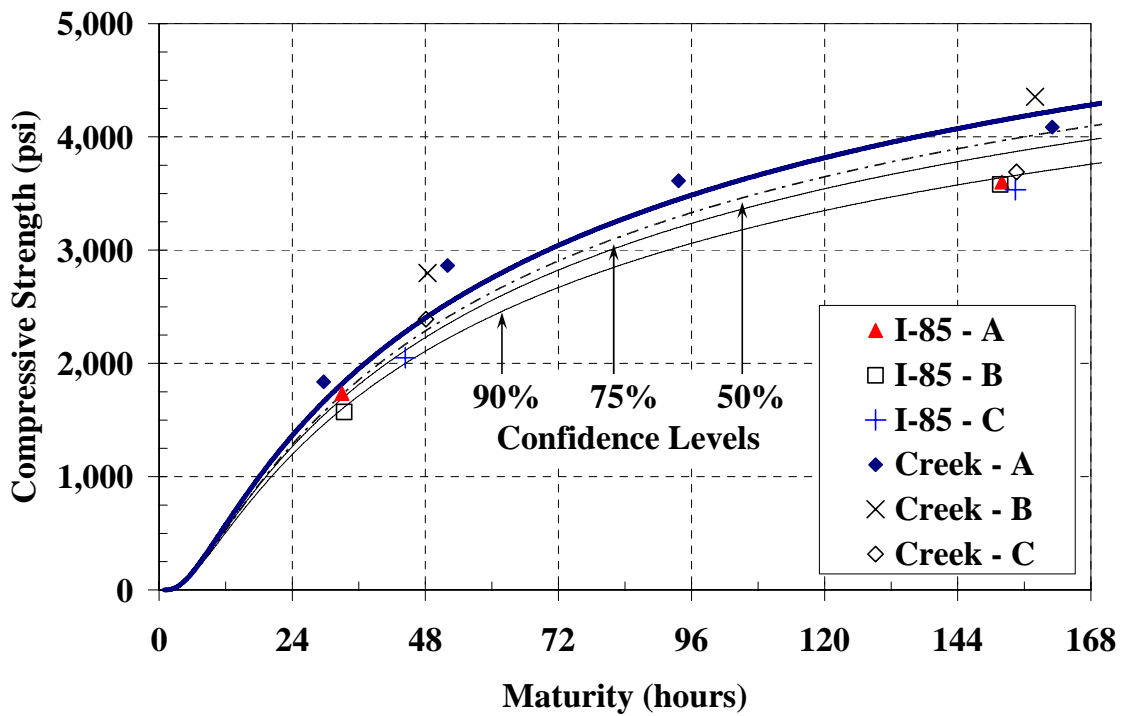

Figure 5-86: I-85 Bridge S-M relationship with confidence levels and verification test results ($E = 33.5 \text{ kJ/mol}$)

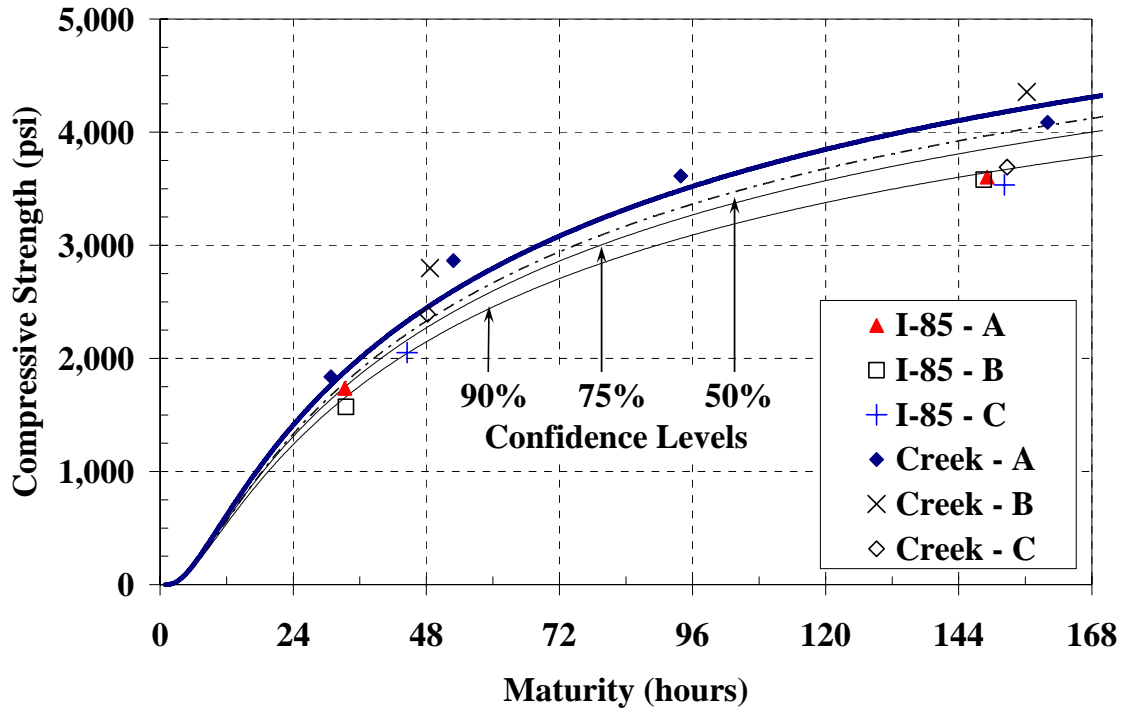

Figure 5-87: I-85 Bridge S-M relationship with confidence levels and verification test results ($E = 40 \text{ kJ/mol}$)

The last set of results that are presented are the estimated in-place strength developments of the actual bridge deck. Once all the temperature developments of the bridge deck were retrieved and the S-M relationships were developed, the strength development of the concrete in the bridge deck was estimated. These graphs illustrate the effects of temperature history on the in-place strength development of the concrete. All four maturity functions were used to estimate the strength development of the concrete, and each of the I-85 Bridge placements are shown in Figures 5-88 to 5-91. The Creek Bridge bridge deck's strength development is presented in Figures 5-92 to 5-95. For each casting segment, only the first and last temperature sensors that were covered with concrete are shown to illustrate the difference in strength development between the beginning and end of a placement. The morning placement (AM) and afternoon

placement (PM) ambient temperature when the concrete was placed is also shown on these Figures 5-88 to 5-95. In addition, the mid-depth sensors were used at both of those locations. All other strength developments for the other sensors were very similar to the strength developments shown here; therefore, those graphs are not presented.

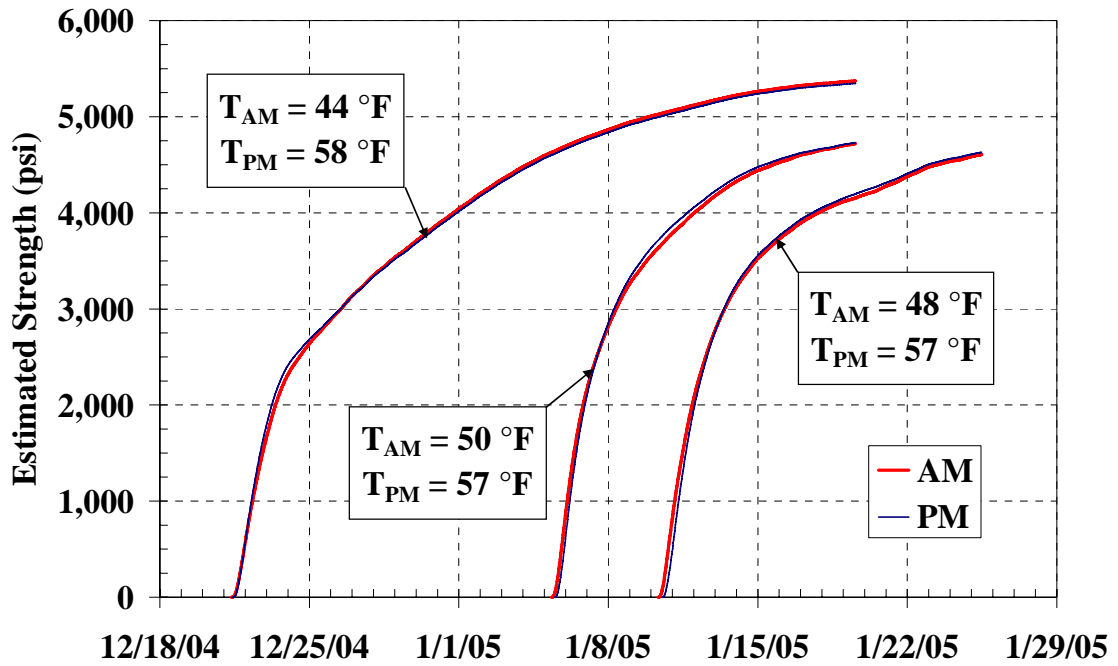

Figure 5-88: I-85 Bridge deck strength development using Nurse-Saul maturity function with $T_o = -10\text{ }^\circ\text{C}$

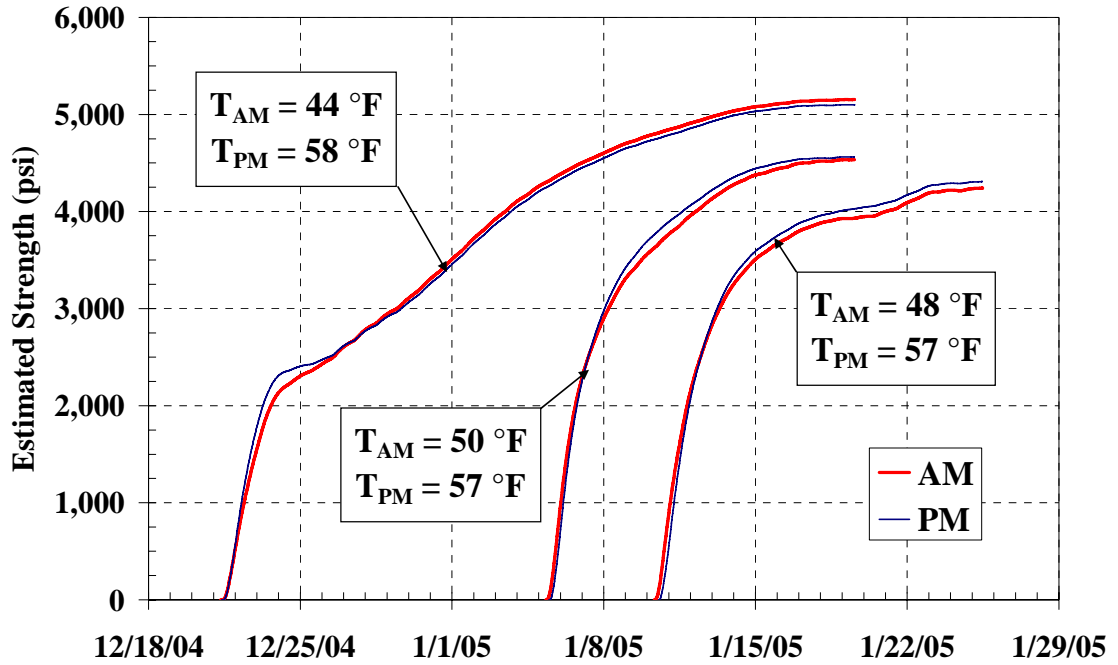

Figure 5-89: I-85 Bridge deck strength development using Nurse-Saul maturity function with $T_o = 0\text{ }^{\circ}\text{C}$

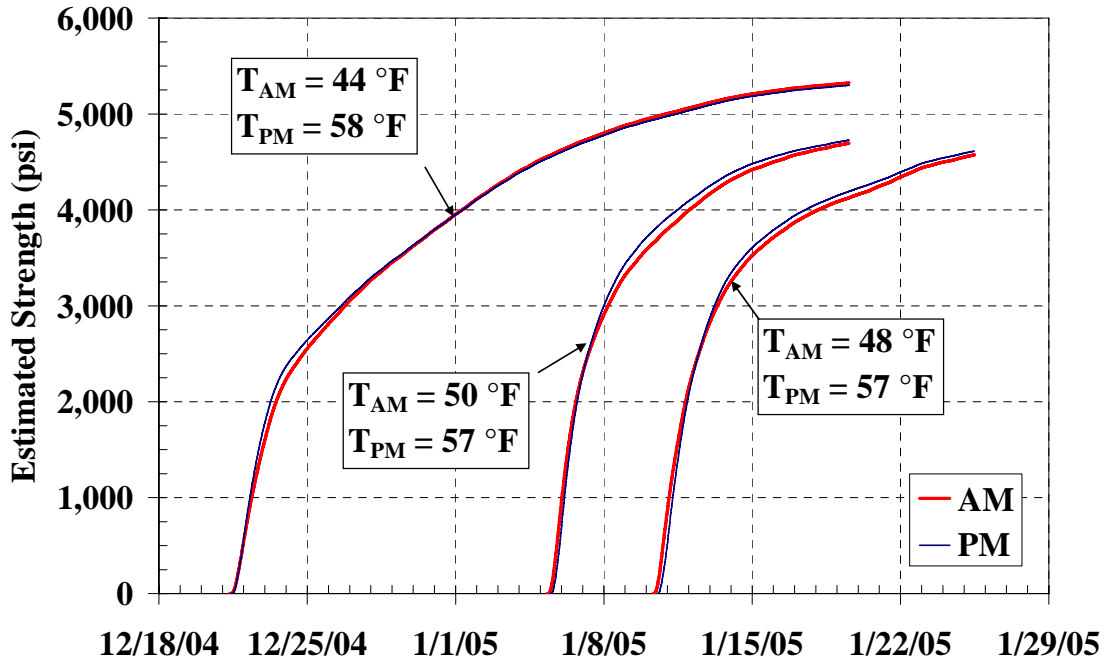

Figure 5-90: I-85 Bridge deck strength development using Arrhenius maturity function with $E = 33.5\text{ kJ/mol}$

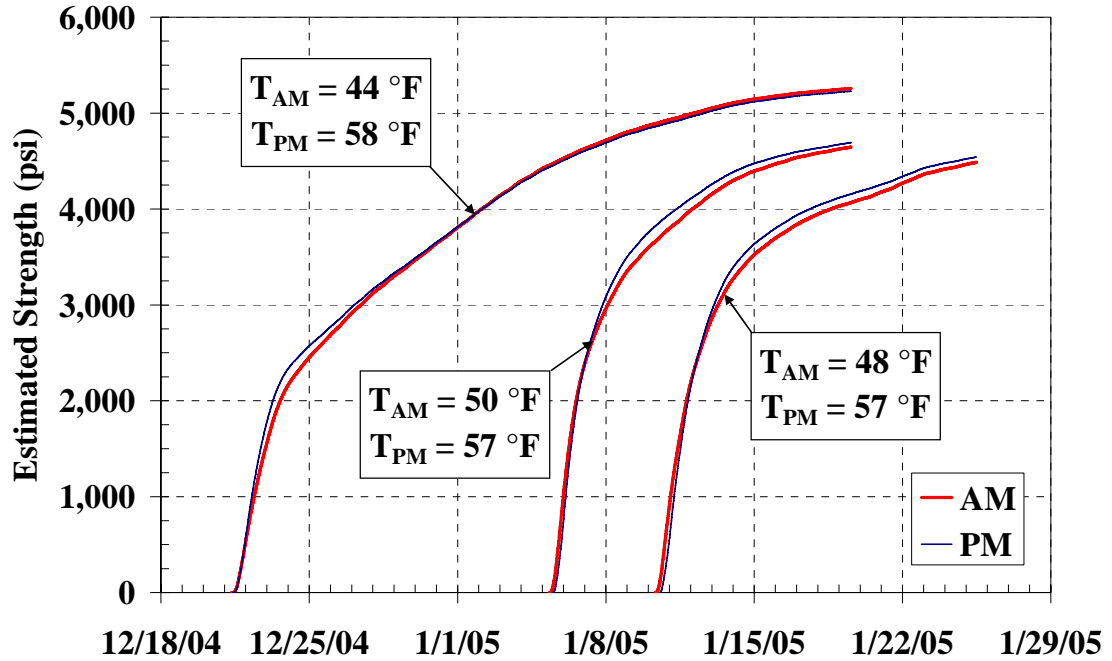

Figure 5-91: I-85 Bridge deck strength development using Arrhenius maturity function with $E = 40\text{ kJ/mol}$

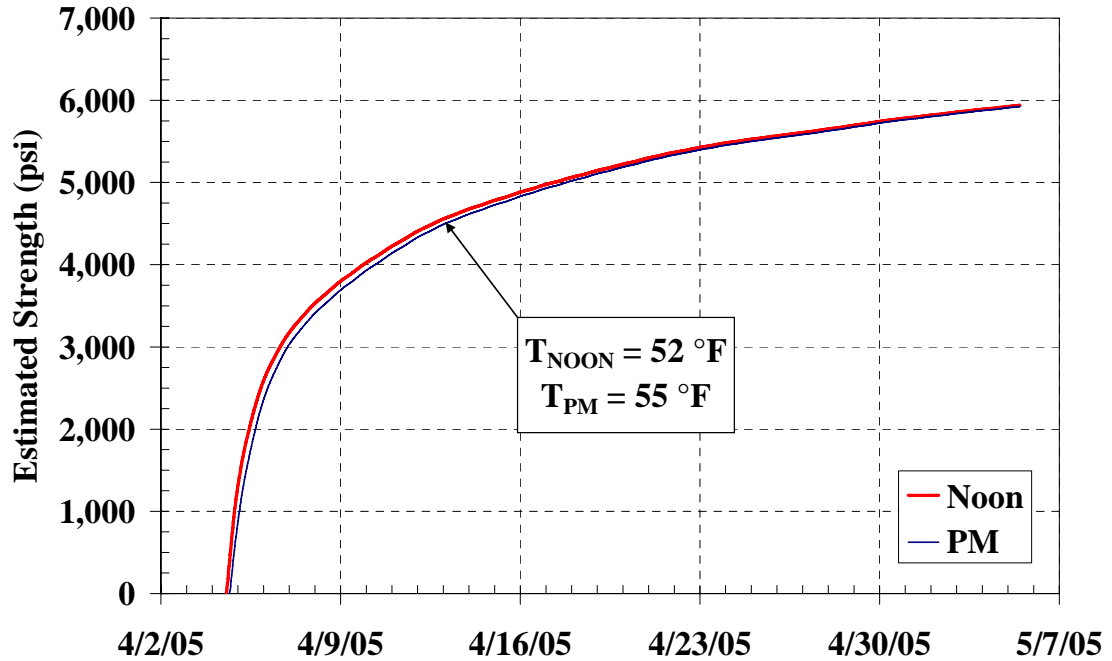

Figure 5-92: Creek Bridge deck strength development using Nurse-Saul maturity function with $T_o = -10\text{ }^{\circ}\text{C}$

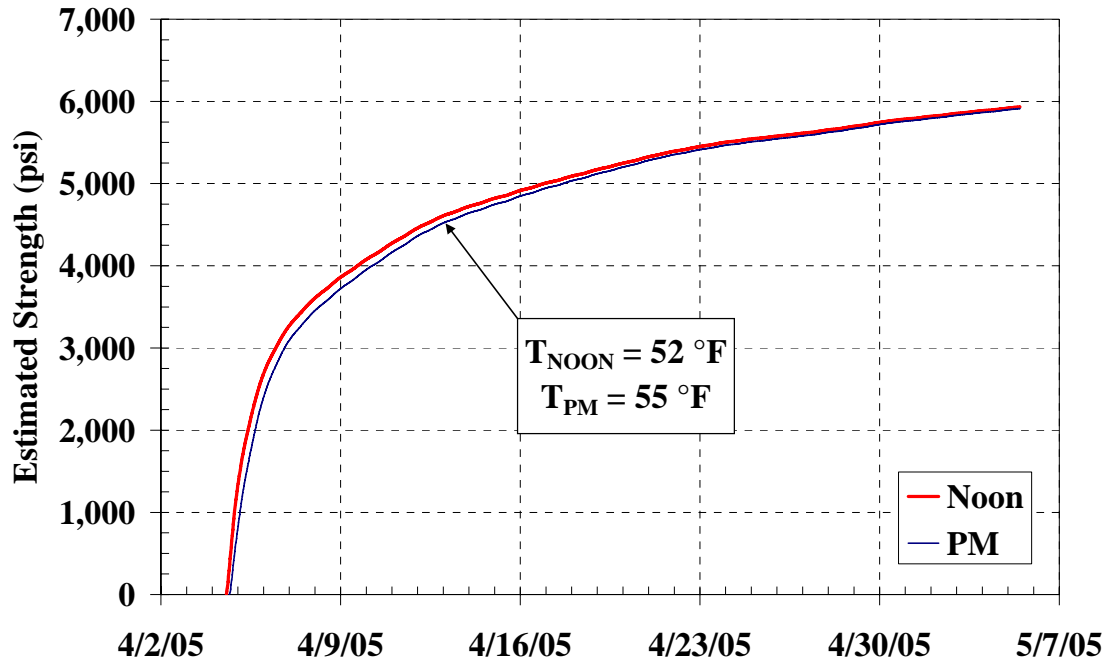

Figure 5-93: *Creek Bridge* deck strength development using Nurse-Saul maturity function with $T_o = 0 \text{ }^\circ\text{C}$

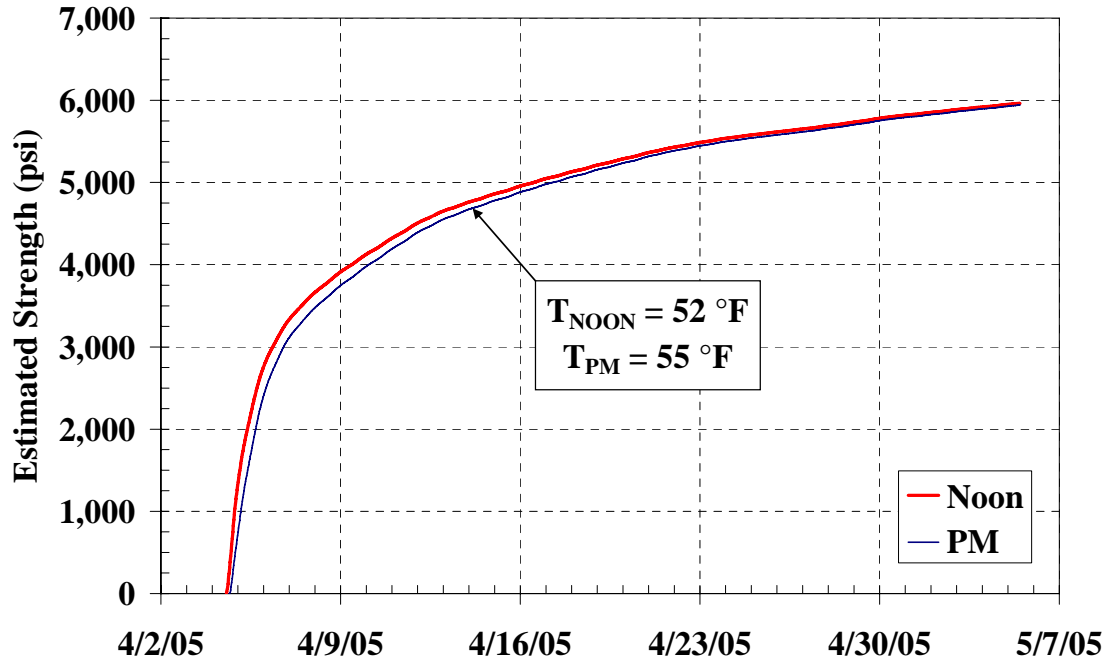

Figure 5-94: *Creek Bridge* deck strength development using Arrhenius maturity function with $E = 33.5 \text{ kJ/mol}$

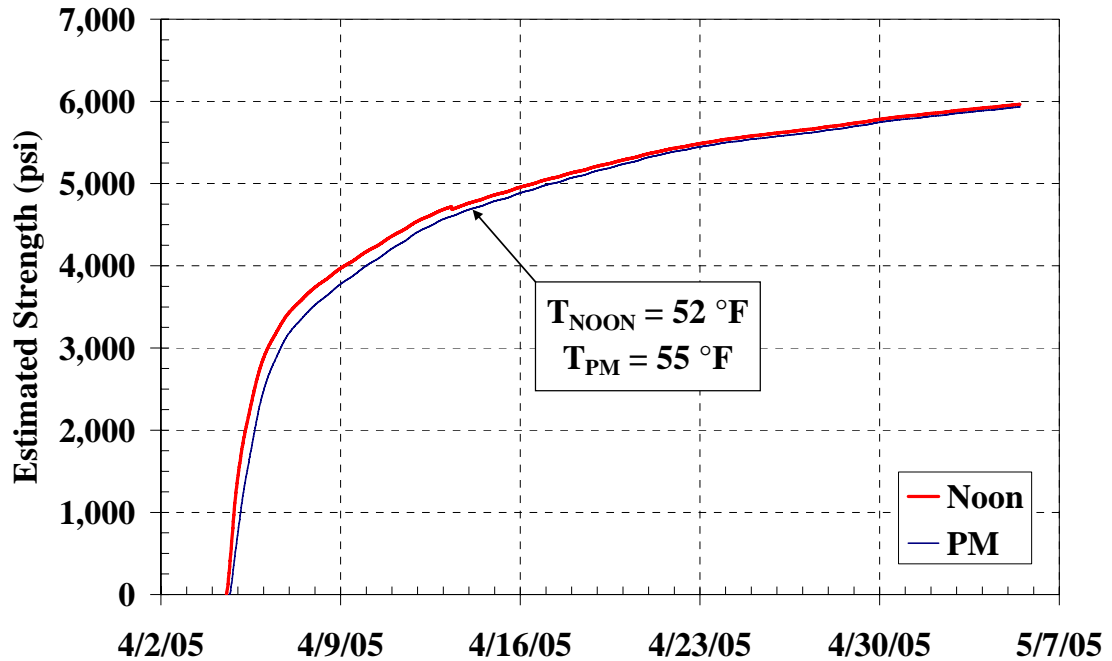

Figure 5-95: *Creek Bridge* deck strength development using Arrhenius maturity function with $E = 40 \text{ kJ/mol}$

5.8 ANALYSIS AND DISCUSSION OF RESULTS

Parameters stated in Section 5.5 were used to determine whether the maturity method is an accurate and appropriate method to estimate the strength development for bridge deck applications. The evaluation of the mock bridge deck and the accuracy of the maturity method to estimate the in-place strength is discussed in Section 5.8.1. The evaluation of the use of molded cylinders for verification testing is discussed in Section 5.8.2. For assessing the accuracy of the maturity method, the acceptable limits described in Section 5.5.6 were used. If the strength of the concrete is overestimated by more than the percent error limit then the maturity method is unconservative, and this condition is unacceptable. On the other hand, if the concrete strength is underestimated, then this is conservative,

and this condition may in some cases be acceptable unless most of the test results are underestimated. An underestimation is conservative and would be acceptable on the construction site when implementing the maturity method.

5.8.1 DISCUSSION OF THE MOCK BRIDGE DECK RESULTS

The primary objectives of the mock bridge deck testing was to assess the accuracy of the maturity method to estimate the in-place strength. In addition, different curing methods to develop the maturity method were evaluated. To determine the accuracy of the maturity method, both cold and warm-weather placement of the mock bridge deck were evaluated together.

5.8.1.1 Accuracy of Various Maturity Methods

Before the accuracy of the maturity method could be assessed, the laboratory S-M relationship for both the cold- and warm-weather placement of the mock bridge was checked to evaluate the fit of the S-M relationship to the strength and maturity data of the laboratory-cured cylinders. The percent errors at each testing age and average absolute error for the entire set were calculated using the strengths from laboratory S-M relationship that corresponded to the measured strengths of the laboratory-cured specimens at the same maturity and presented in Table 5-31 for the cold-weather placement and Table 5-32 for the warm-weather placement. The percent errors were calculated using Equation 4-1 and the average absolute error was calculated using Equation 4-2. The strengths from the laboratory S-M relationship that correspond to the laboratory-cured cylinder strengths for both placements of the mock bridge deck are

presented in Appendix C. If the percent error is negative, then the maturity method underestimates the strength, and if the error is positive, then the maturity method overestimates the strength. As long as the maturity method does not overestimate the strength by more than 10%, then the maturity method is considered accurate to estimate the strength of the molded cylinders.

Table 5-31: Evaluation of the errors of the *laboratory* S-M relationship for cold-weather placement laboratory-cured cylinders

	Concrete Age (hours)	Nurse-Saul Function		Arrhenius Function	
		T _o = -10 °C	T _o = 0 °C	E = 40 kJ/mol	E = 33.5 kJ/mol
<i>Percent Error</i>	26.8	8%	8%	8%	8%
	49.4	-3%	-3%	-3%	-3%
	73.6	-2%	-2%	-2%	-2%
	170.3	1%	1%	1%	1%
	336.9	2%	2%	2%	2%
	672.4	-1%	-1%	-1%	-1%
<i>Average Absolute Error (psi)</i>		67	67	67	67

- Negative percent error reflects an underestimation of the measured strength
+ Positive percent error reflects an overestimation of the measured strength

Table 5-32: Evaluation of the errors of the *laboratory* S-M relationship for warm-weather placement laboratory-cured cylinders

	Concrete Age (hours)	Nurse-Saul Function		Arrhenius Function	
		T _o = -10 °C	T _o = 0 °C	E = 40 kJ/mol	E = 33.5 kJ/mol
<i>Percent Error</i>	25.6	9%	9%	10%	10%
	50.3	-7%	-7%	-7%	-7%
	72.3	-4%	-4%	-4%	-4%
	170.1	4%	4%	4%	4%
	336.1	1%	1%	1%	1%
	674.2	-1%	-1%	-1%	-1%
<i>Average Absolute Error (psi)</i>		132	134	138	136

- Negative percent error reflects an underestimation of the measured strength
+ Positive percent error reflects an overestimation of the measured strength

When examining the average absolute error for laboratory sets of cylinders, the average absolute error was 67 psi for the cold-weather placement and ranged from 132 to 138 psi for the warm-weather placement for all four maturity methods. The average absolute errors were below 200 psi which indicates that both laboratory S-M relationships fit the corresponding sets of laboratory strength and maturity data very well. All of the percent errors were within 10%, which indicates that the laboratory S-M relationship was a good fit for the laboratory-cured cylinders.

ASTM C 1074 (2004) recommends that the S-M relationship be developed with cylinders cured in laboratory conditions. The average absolute errors and percent errors at each testing age were calculated to compare the estimated strength from the laboratory S-M relationship to the measured strength of the water-tank-cured cylinders for both the cold and warm-weather placement. The average absolute errors and percent error for the cold-weather placement are presented in Tables 5-33 and for the warm-weather placement are presented in Table 5-34. The estimated strengths from the laboratory S-M relationship for water-tank-cured cylinder for both mock bridge deck placements are presented in Appendix C. The estimated strength from the laboratory S-M relationship versus the corresponding measured strengths for all sets of cylinders and both placements are presented in Figures 5-96 to 5-99. A 45°-line was plotted on the graphs to illustrate where the estimated strengths and measured strengths are equal. In addition, $\pm 10\%$ and $\pm 20\%$ error lines are added to the plots to show the magnitude of the error. If the error was negative, then the maturity method underestimated the strength (which is conservative), and if the error was positive then the maturity method overestimated the strength.

Table 5-33: Percent errors and average absolute percent errors for water-tank-cured cylinder data using *laboratory* S-M relationships for the cold-weather placement of the mock bridge deck

	Concrete Age (hours)	Nurse-Saul Function		Arrhenius Function	
		T _o = -10 °C	T _o = 0 °C	E = 40 kJ/mol	E = 33.5 kJ/mol
<i>Percent Error</i>	27.0	17%	7%	4%	10%
	49.2	14%	1%	2%	7%
	73.4	1%	-10%	-9%	-4%
	170.2	-11%	-22%	-18%	-14%
	335.9	-8%	-16%	-13%	-10%
	672.3	1%	-4%	-2%	0%
<i>Average Absolute Error (psi)</i>		180	338	201	235

- Negative percent error reflects an underestimation of the measured strength
+ Positive percent error reflects an overestimation of the measured strength

Table 5-34: Percent errors and average absolute percent errors for water-tank-cured cylinder data using *laboratory* S-M relationships for the warm-weather placement of the mock bridge deck

	Concrete Age (hours)	Nurse-Saul Function		Arrhenius Function	
		T _o = -10 °C	T _o = 0 °C	E = 40 kJ/mol	E = 33.5 kJ/mol
<i>Percent Error</i>	25.4	14%	16%	19%	18%
	49.0	2%	3%	5%	4%
	72.2	7%	8%	10%	8%
	169.8	6%	7%	8%	7%
	335.9	8%	8%	10%	9%
	673.8	8%	9%	10%	9%
<i>Average Absolute Error (psi)</i>		253	285	340	310

- Negative percent error reflects an underestimation of the measured strength
+ Positive percent error reflects an overestimation of the measured strength

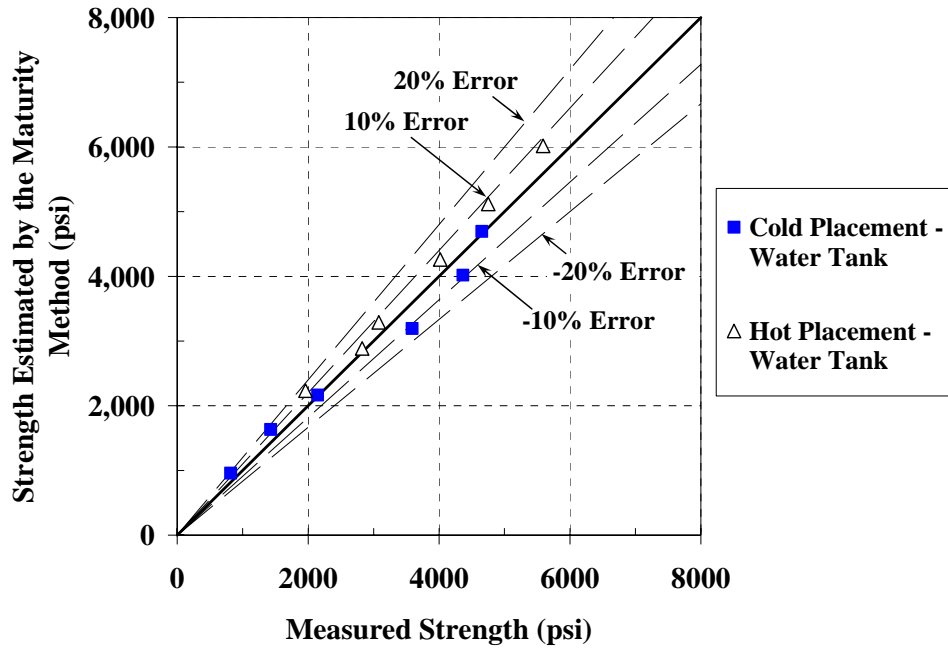

Figure 5-96: 45°-line graph for estimated cylinder strengths from the *laboratory* S-M relationship using the Nurse-Saul maturity function ($T_0 = -10\text{ }^\circ\text{C}$)

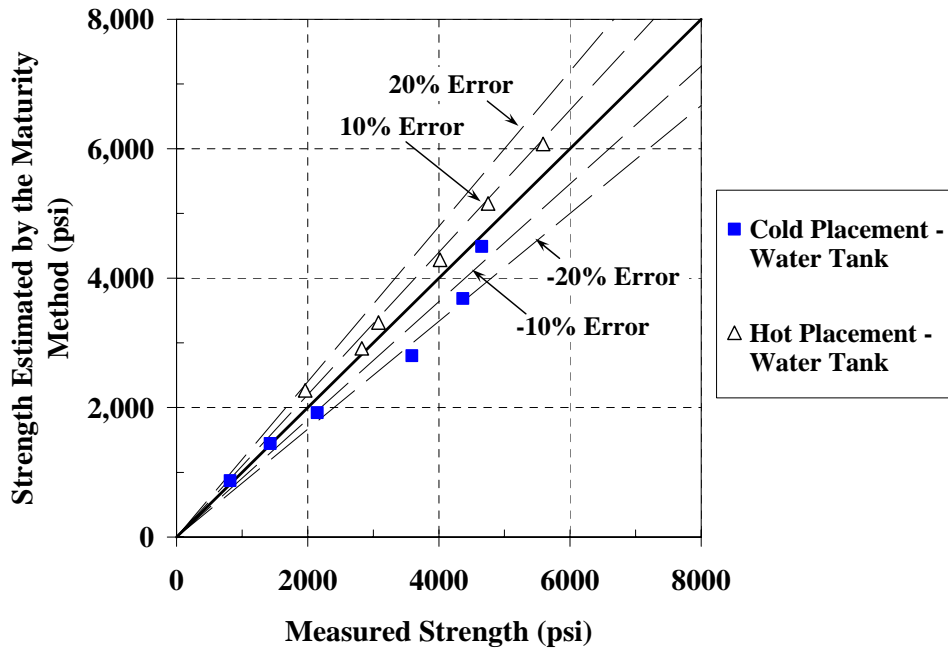

Figure 5-97: 45°-line graph for estimated cylinder strengths from the *laboratory* S-M relationship using the Nurse-Saul maturity function ($T_0 = 0\text{ }^\circ\text{C}$)

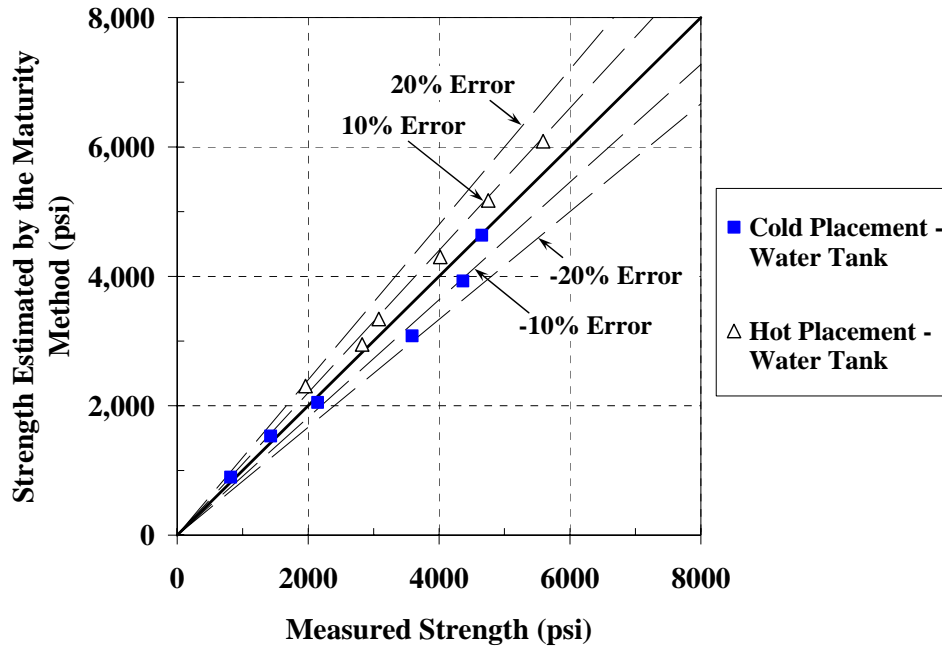

Figure 5-98: 45°-line graph for estimated cylinder strengths from the *laboratory* S-M relationship using the Arrhenius maturity function ($E = 33.5$ kJ/mol)

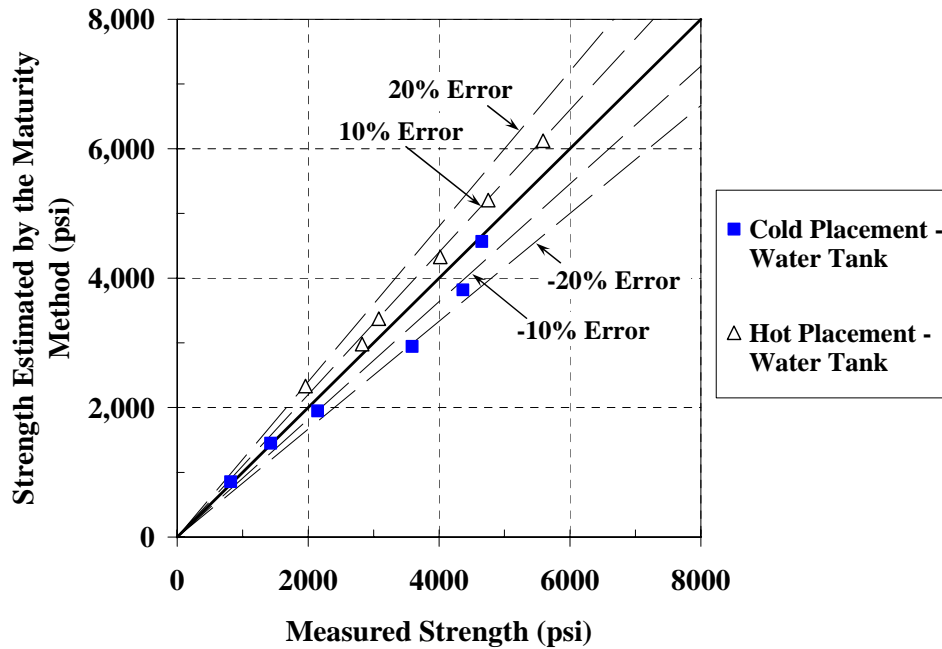

Figure 5-99: 45°-line graph for estimated cylinder strengths from the *laboratory* S-M relationship using the Arrhenius maturity function ($E = 40$ kJ/mol)

In analyzing the accuracy of the laboratory S-M relationship to estimate the strength of the water-tank-cured cylinders, a couple of trends were observed. The first was that for all maturity functions for the cold-weather placement, the 7-day strengths were underestimated by more than 10%. Although underestimating the strength is conservative, this indicates that the laboratory S-M relationship is not estimating the strength development of the water-tank-cured cylinders that accurately. For discussion purposes the testing ages of 1, 2, 3, and 7 days will be referred to “early-age” and the testing ages of 14 and 28 days will be referred to as “later-age.”

The average absolute errors for the different datum temperatures for the Nurse-Saul maturity function using the laboratory S-M relationship ranged from 180 psi for a datum temperature of -10°C and 338 psi for a datum temperature of 0°C for the cold-weather placement. This indicates that the datum temperature of -10°C was better at estimating the strength of the water-tank-cured cylinders than the datum temperature of 0°C . For the warm-weather placement, the average absolute error ranged from 253 psi for datum temperature of -10°C and 285 psi for a datum temperature of 0°C for the Nurse-Saul maturity function using the laboratory S-M relationship, which indicates that both datum temperatures fit the best-fit S-M relationship approximately the same.

At ages of 1 and 2 days, the Nurse-Saul maturity function with a datum temperature of -10°C overestimated the strength of the water-tank-cured cylinders by more than 10% for the cold-weather placement. The datum temperature of 0°C on the other hand stayed within the 10% limit for the first two testing ages and only overestimated the strength of the concrete by 7% for the 1-day testing age. From evaluating the early-age percent errors for the cold-weather placement, the datum

temperature of 0 °C estimated the strength of the water-tank-cured cylinder more accurately than the datum temperature of -10 °C. This is the opposite of what was found when evaluating the average absolute error for these two datum temperatures. The average absolute error indicated that the datum temperature of -10 °C was more accurate because the average absolute error does not take into account the magnitude of the error at each testing age as does the percent error. On the other hand, the percent error does indicate that the datum temperature of 0 °C provided a more accurate estimate of the early-age strength of the concrete than the datum temperature of -10 °C.

The Arrhenius maturity function tends to have average absolute errors that are very close for both activation energies. For the cold-weather placement, the average absolute error ranged from 201 to 235 psi, and for the warm-weather placement the average absolute error ranged from 310 to 340 psi. For the cold-weather placement, both activation energies provided similar estimates of the strength of the water-tank-cured cylinders, unlike the larger difference in the average absolute error between the two datum temperatures for the cold-weather placement. Since the difference between average absolute errors for both activation energies evaluated was about 30 psi for both placements of the mock bridge deck, neither of the activation energies can be concluded to provide better strength estimates.

The Arrhenius maturity function for the laboratory S-M relationship results in estimates of the water-tank-cured cylinder strength fell within the 10% limit for the first three testing ages, which is similar to the cold-weather placement datum temperature of 0 °C. It should be noted that the 14-day strength for cold-weather placement tended to be underestimated by more than 10% for most of the maturity functions. The fact that the

laboratory S-M maturity relationship underestimates the 14-day strength for the water-tank-cured cylinders and estimates the early-age and 28 day strength fairly accurately indicates that the laboratory S-M relationship does not accurately assess the strength development of the water-tank-cured cylinders for the cold-weather placement.

For the warm-weather placement, the only percent error that exceeded the 10% limit was the first testing age. This could be attributed to the fact that concrete tested at very early ages tends to have a slightly higher variability than concrete at later ages. The fact that the percent errors for all other testing ages of all other maturity functions were within the 10% limit indicates that the maturity method estimated the rest of the strength development of the concrete accurately. In comparing the different datum temperatures for the warm-weather placement, both datum temperatures had approximately the same errors, and no conclusion could be made about which was more accurate. The errors of both the activation energies for the warm-weather placement were also close, which indicates both activation energies estimated the warm-weather placement strength accurately.

In summary, all the maturity methods work well for estimating the strength of the molded cylinders for the warm-weather placement with the exception of the 1 day test, and no one maturity method was much more accurate than the others for estimating the strength of the concrete. There was such a large error for all the maturity function at 14-day testing for the cold-weather placement; this indicates the laboratory S-M relationship does not accurately estimate the concrete strength for the water-tank-cured cylinders for the cold-weather placement. Therefore, the evaluation of accuracy of the different curing methods to estimate the in-place strength will be used to determine which curing method

and maturity function is the most accurate for estimating the strength of the concrete. The maturity method will most likely be used for early-age estimation of the concrete strength, so testing ages of 7 days and earlier should therefore have the most influence in evaluating the accuracy of the maturity method. This approach is similar to what was concluded in Phase I of this research effort as discussed in Section 3.4.

5.8.1.2 Accuracy of the Maturity Method to Assess Strength of the 4 x 8 inch Water-Tank-Cured Cylinders

Water-tank-cured 4 x 8 inch cylinders were used to eliminate strength difference that may occur between cylinders of different size. All cast-in-place cylinders and cores had dimensions of 4 x 8 inches. If the strength of the water-tank-cured 4 x 8 cylinders is estimated accurately from the S-M relationships developed from the 6 x 12 inch cylinders, then the S-M relationships developed from the 6 x 12 inch cylinders are considered adequate for estimating the compressive strength of cast-in-place cylinders and cores.

If the water-tank-cured 4 x 8 inch cylinder strengths are overestimated by more than 10%, using the maturity method, then the maturity method will not be considered accurate for estimating the strength of these cylinders. All the estimated strengths for the water-tank-cured 4 x 8 inch cylinders from all four maturity functions and two different curing methods are presented in Appendix C.

The percent errors and average absolute percent errors for the water-tank-cured 4 x 8 inch cylinders are presented in Tables 5-35 and 5-36 for using the laboratory S-M relationship for the cold- and warm-weather placement, respectively. The 45°-line graphs

for using the estimated strength for the Nurse-Saul maturity function with $T_o = 0\text{ }^\circ\text{C}$ and Arrhenius maturity function with $E = 33.5\text{ kJ/mol}$ are presented in Figure 5-100 and 5-101. The 45°-line graphs for the using the estimated strength Nurse-Saul maturity function with $T_o = -10\text{ }^\circ\text{C}$ and Arrhenius maturity function with $E = 40\text{ kJ/mol}$ are presented in Appendix C.

Table 5-35: Percent errors for water-tank-cured 4 x 8 inch cylinder using *laboratory* S-M relationship for the cold-weather placement

	Concrete Age (Days)	Nurse-Saul Function		Arrhenius Function	
		$T_o = -10\text{ }^\circ\text{C}$	$T_o = 0\text{ }^\circ\text{C}$	$E = 40\text{ kJ/mol}$	$E = 33.5\text{ kJ/mol}$
Percent Errors	1.1	14%	0%	-3%	5%
	2.1	22%	5%	6%	13%
	7.1	-8%	-19%	-15%	-11%
	28.0	-6%	-10%	-8%	-7%
Average Absolute % Error		12%	8%	8%	9%

Table 5-36: Percent errors for water-tank-cured 4 x 8 inch cylinder using *laboratory* S-M relationship for the warm-weather placement

	Concrete Age (Days)	Nurse-Saul Function		Arrhenius Function	
		$T_o = -10\text{ }^\circ\text{C}$	$T_o = 0\text{ }^\circ\text{C}$	$E = 40\text{ kJ/mol}$	$E = 33.5\text{ kJ/mol}$
Percent Errors	1.1	-26%	-37%	-33%	-29%
	2.1	14%	10%	10%	11%
	7.1	1%	0%	1%	1%
	28.0	-4%	-4%	-5%	-5%
Average Absolute % Error		11%	13%	12%	11%

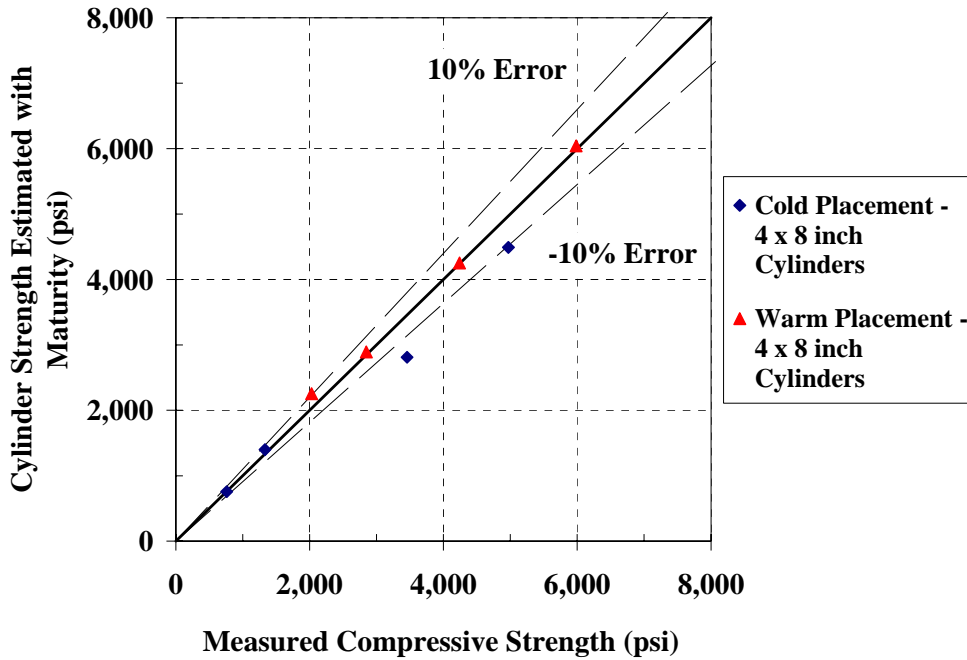

Figure 5-100: 45°-line graph for estimating the strength of water-tank-cured 4 x 8 inch cylinder from the mock bridge deck *laboratory* S-M relationships using the Nurse-Saul maturity function ($T_0 = 0\text{ }^\circ\text{C}$)

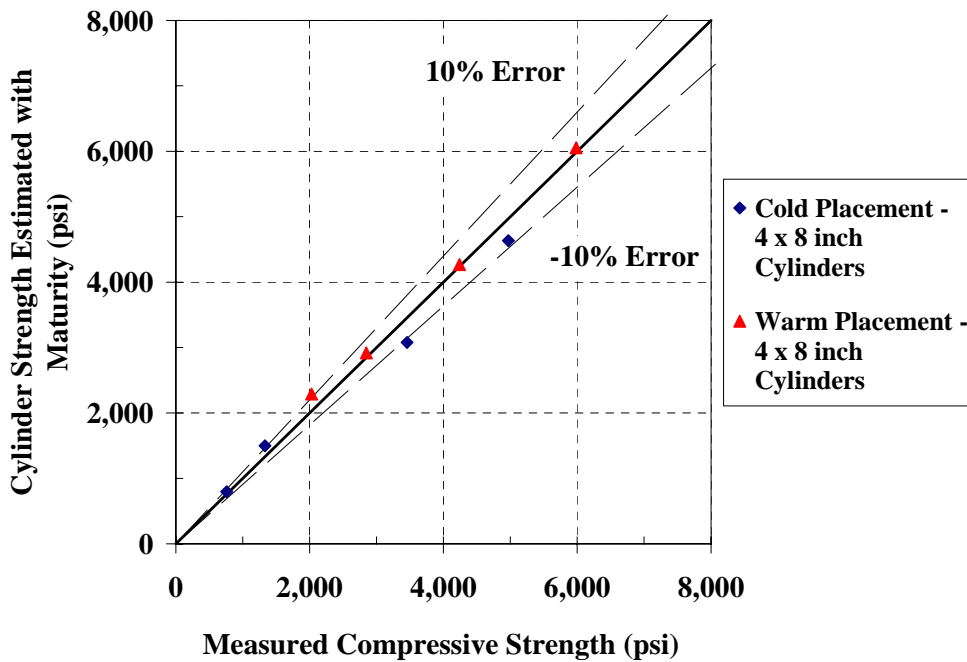

Figure 5-101: 45°-line graph for estimating the strength of water-tank-cured 4 x 8 inch cylinder from the mock bridge deck *laboratory* S-M relationships using the Arrhenius maturity function ($E = 33.5\text{ kJ/mol}$)

An evaluation of the 4 x 8 cylinder data reveals that the Nurse-Saul maturity function with $T_o = 0\text{ }^\circ\text{C}$ was the most accurate for estimating the 4 x 8 inch cylinder strength when considering both the cold and warm-weather placement together. The average absolute percent error was 8% for the cold-weather placement and 3% for the warm-weather placement, which is the lowest average absolute percent error for both data sets. For the cold-weather placement, the percent error limit of 10% was exceeded for all maturity functions, which indicates that the laboratory S-M relationship had some difficulty estimating the 4 x 8 cylinders strength accurately. The Nurse-Saul maturity function with $T_o = -10\text{ }^\circ\text{C}$ overestimate the cold-weather placement strength by more than 10% for the 1 and 2 day testing ages. The laboratory S-M relationship for the warm-weather placement was more accurate than the cold-weather placement; however, the 10% limit was exceeded for the 1-day testing age for both the activations energies and the datum temperature of $0\text{ }^\circ\text{C}$. This trend of exceeding 10% limit for the 1-day testing age was the same as the laboratory S-M relationship to estimate the strength of the 6 x 12 inch water-tank-cured cylinder for the warm-weather placement. The Nurse-Saul maturity function with a $T_o = 0\text{ }^\circ\text{C}$ was fairly accurate for estimating the strength of the water-tank-cured 4 x 8 inch cylinders for the cold- and warm-weather placements.

The water-tank S-M relationships were evaluated next. The percent errors and average absolute percent errors for the 4 x 8 inch cylinders strength data using the water-tank S-M relationship are presented in Tables 5-37 and 5-38 for the cold-weather placement and warm-weather placement, respectively. The 45°-line graphs using the estimated strength for the Nurse-Saul maturity function with $T_o = 0\text{ }^\circ\text{C}$ and Arrhenius maturity function with $E = 33.5\text{ kJ/mol}$ are presented in Figures 5-102 and 5-103. The

45°-line graphs using the estimated strength for the Nurse-Saul maturity function with $T_o = -10\text{ °C}$ and Arrhenius maturity function with $E = 40\text{ kJ/mol}$, they are presented

Appendix C.

Table 5-37: Percent errors for 4 x 8 inch cylinder strengths using *water-tank* S-M relationship for the cold-weather placement

Concrete Age (Days)	Nurse-Saul Function		Arrhenius Function	
	$T_o = -10\text{ °C}$	$T_o = 0\text{ °C}$	$E = 40\text{ kJ/mol}$	$E = 33.5\text{ kJ/mol}$
1.1	-26%	-37%	-33%	-29%
2.1	14%	10%	10%	11%
7.1	1%	0%	1%	1%
28.0	-4%	-4%	-5%	-5%
Average Absolute % Error	11%	13%	12%	11%

Table 5-38: Percent errors for 4 x 8 inch cylinder strengths using *water-tank* S-M relationship for the warm-weather placement

Concrete Age (Days)	Nurse-Saul Function		Arrhenius Function	
	$T_o = -10\text{ °C}$	$T_o = 0\text{ °C}$	$E = 40\text{ kJ/mol}$	$E = 33.5\text{ kJ/mol}$
1.0	0%	0%	-1%	0%
2.0	-6%	-6%	-6%	-6%
7.1	-5%	-6%	-6%	-6%
28.1	-8%	-8%	-8%	-8%
Average Absolute % Error	5%	5%	5%	5%

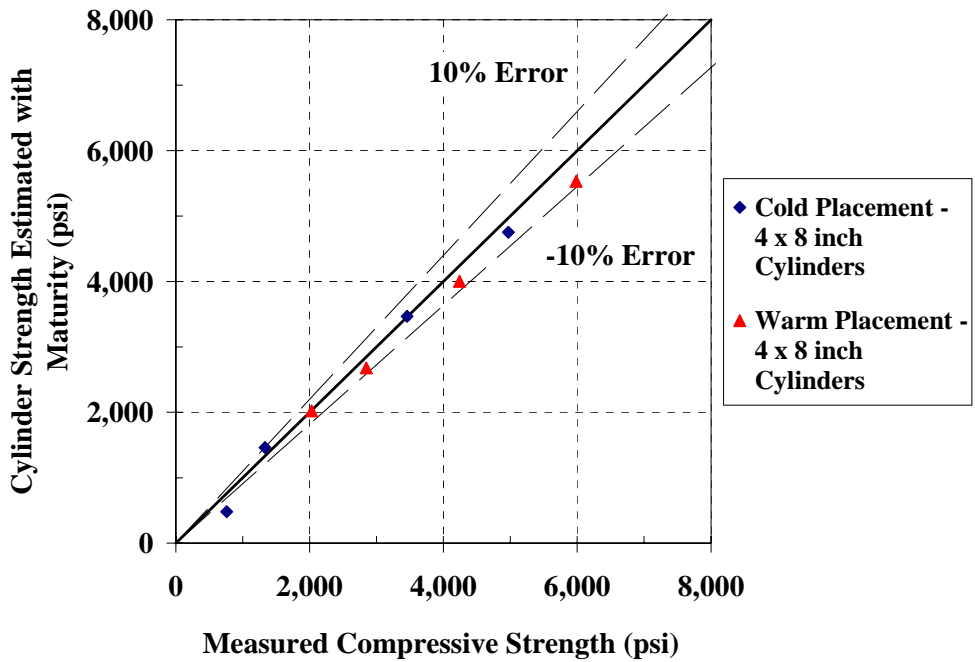

Figure 5-102: 45°-line graph for estimating the strength of water-tank-cured 4 x 8 inch cylinder from the mock bridge deck *water-tank* S-M relationships using the Nurse-Saul maturity function ($T_0 = 0\text{ }^{\circ}\text{C}$)

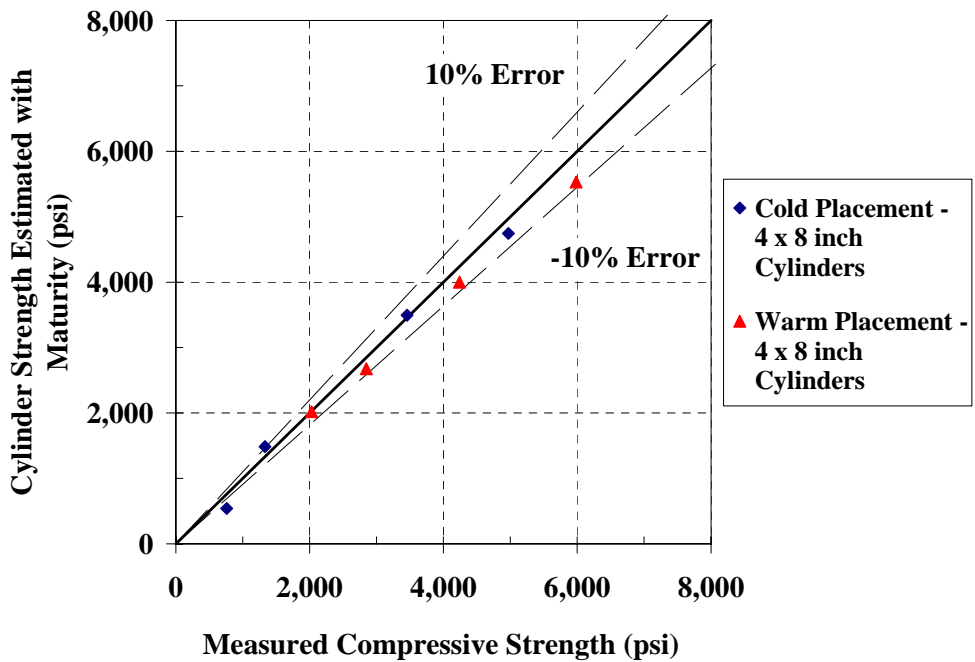

Figure 5-103: 45°-line graph for estimating the strength of water-tank-cured 4 x 8 inch cylinder from the mock bridge deck *water-tank* S-M relationships using the Arrhenius maturity function ($E = 33.5\text{ kJ/mol}$)

When evaluating the water-tank S-M relationships, the percent errors were much smaller than for the laboratory S-M relationship. The only percent error that exceeded the 10% limit for all the maturity functions was the cold-weather placement 1 day test. The average measured compressive strength of that test was below 1,000 psi, which could indicate that the test might have been conducted too early to evaluate the strength of the concrete accurately. Also the strength at that age was underestimated, which is conservative; therefore, the 1-day testing age for the cold-weather placement was not strongly considered when determining the accuracy of the maturity method to estimate the 4 x 8 inch cylinder strength. The 2-day cold-weather placement test using Nurse-Saul maturity function with $T_o = -10\text{ }^{\circ}\text{C}$ was overestimated by more than 10%, which is not accurate. Whereas, the 2-day cold-weather placement using the Nurse-Saul maturity function with $T_o = 0\text{ }^{\circ}\text{C}$ was estimated within the 10% limit. All of the maturity functions estimated the strength of the 4 x 8 inch cylinders from the warm-weather placement to be approximately the same. The average absolute errors were close enough that a definitive conclusion could not be made regarding which maturity function was the most accurate.

In summary, the water-tank S-M relationship was more accurate at estimating the in-place strength for the 4 x 8 inch molded cylinders than the laboratory S-M relationship. Since the water-tank S-M relationship was accurate at estimating the strength of the 4 x 8 molded cylinders, the water-tank S-M relationships can be used to assess the accuracy of the maturity method to estimate the strength of the cast-in-place cylinders and cores. It should be noted for the Nurse-Saul maturity function that the $T_o = 0\text{ }^{\circ}\text{C}$ was the more accurate datum temperature, and that the cold-weather placement 2-day testing age for $T_o = -10\text{ }^{\circ}\text{C}$ was overestimated and should be considered inaccurate.

5.8.1.3 Accuracy of the Pullout Table Supplied By LOK-Test Supplier

The pullout table was found to be accurate for the prestressed girder project, but more testing was conducted to provide sufficient data to provide more confidence with these results. The pullout tests from cubes were conducted on both placements of the mock bridge deck. To determine if the pullout table supplied by Germann Instruments is accurate, the pullout test data from cubes were analyzed as stated in Section 5.1.2.3. Since the cubes were cured in the water-tank, as was the case in the prestressed plant project, the compressive strengths from the pullout table that correlated to the pullout force recorded were compared to the strength estimated from the water-tank S-M relationship at the same maturity. Moreover, since the Arrhenius maturity function with $E = 40 \text{ kJ/mol}$ and the Nurse-Saul maturity function with $T_0 = 0 \text{ }^\circ\text{C}$ were used in the prestressed girder project, they were again used for this analysis.

The estimated strengths from the water-tank S-M relationship that correspond to the pullout strengths obtained from the pullout table at each age are presented in Appendix C. The percent errors calculated for the pullout test performed on the cubes are presented in Table 5-39. In addition, the 45°-line graphs showing the strength estimated by the water-tank S-M relationship versus the strength from the pullout correlation table for both cold and warm-weather placements are presented in Figures 5-104 and 5-105. The other two 45°-line graphs for the Nurse-Saul maturity function with $T_0 = -10 \text{ }^\circ\text{C}$ and Arrhenius maturity function with $E = 33.5 \text{ kJ/mol}$ are presented in Appendix C.

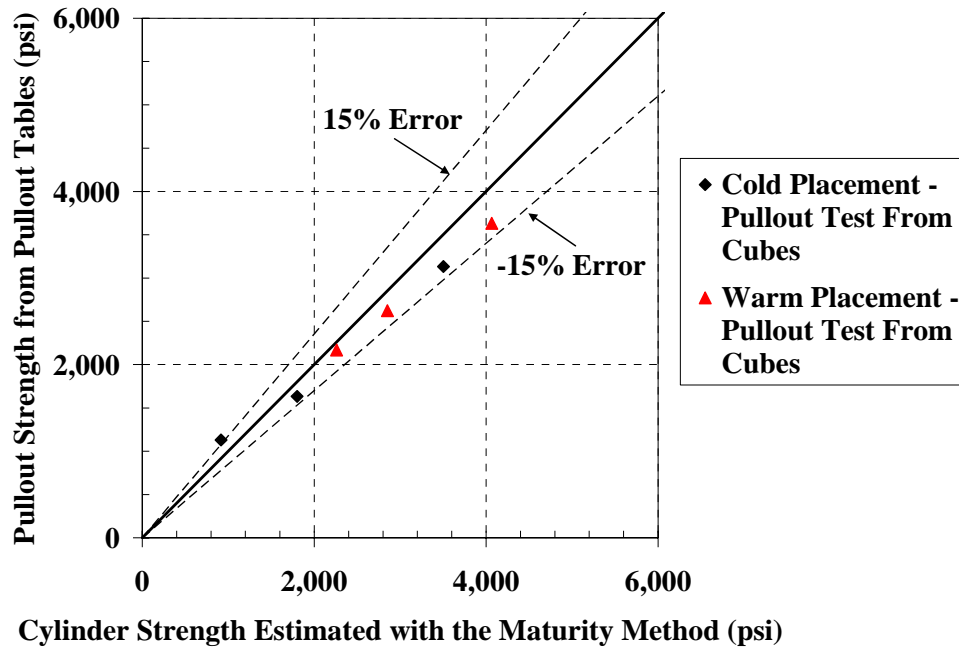

Figure 5-104: 45°-line graph to evaluate the pullout table using estimated strength from *water-tank* S-M relationship using the Nurse-Saul maturity function ($T_0 = 0\text{ }^{\circ}\text{C}$)

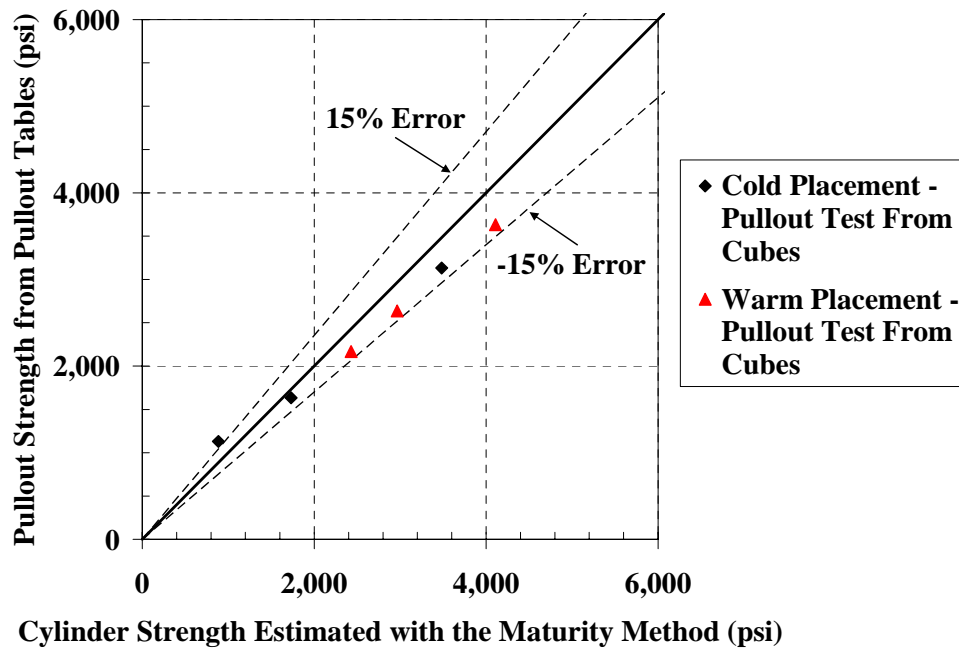

Figure 5-105: 45°-line graph to evaluate the pullout table using estimated strength from *water-tank* S-M relationship using the Arrhenius maturity function ($E = 40\text{ kJ/mol}$)

Table 5-39: Percent error for pullout cube strength from *water-tank* S-M relationship

Placement	Concrete Age (hours)	Percent Error (%)			
		Nurse-Saul Function		Arrhenius Function	
		T _o = -10 °C	T _o = 0 °C	E = 33.5 kJ/mol	E = 40 kJ/mol
<i>Cold</i>	26.2	43%	23%	27%	18%
	48.5	-2%	-9%	-6%	-9%
	157.6	-10%	-11%	-10%	-11%
<i>Warm</i>	24.3	-1%	-4%	-11%	-15%
	48.5	-6%	-7%	-11%	-13%
	168.8	-11%	-11%	-12%	-12%

As stated in Section 5.5.6, if the pullout test from the cubes have a percent error of more than 15% then the correlation table will be considered invalid. All of the testing ages with the exception of the cold-weather placement 1 day testing age were within the 15% limit of the estimated strength from all of the different maturity methods. When examining the 1-day testing age for the cold-weather placement the estimated strength for all the maturity functions range between 790 to 960 psi strength and the measured strength was 1,030 psi. These strengths are sufficiently low that the maturity method will likely never be used for estimating strengths in this low range. For all other reasonable strengths above 1,630 psi (the 2 day testing age for the cold-weather placement) the pullout table correlated the compressive strength and the pullout force sufficiently accurately.

5.8.1.4 Accuracy of the Maturity Method to Assess In-Place Strengths

The in-place strength was quantified by the pullout test, compression testing of cast-in-place cylinders, and compression testing of cores extracted from the mock bridge decks.

When evaluating the pullout test and the compression testing of cores, the acceptance criteria of 15% error was used, as stated in Section 5.5.6. If the percent error differs by more than 15% for many of the tests, then the maturity method was considered inaccurate to estimate the in-place strength. For the cast-in-place cylinders, the acceptance criteria of 10% was used, as stated in Section 5.5.6. This criterion was the same as for the 6 x 12 inch and 4 x 8 inch molded cylinders. Both the cold and warm-weather placement of the mock bridge deck will be evaluated together. For evaluating the accuracy of the maturity method, the testing ages 1, 2, 3, and 7 days will be used since the maturity method is especially useful in estimating early-age concrete strength and the accuracy of the method up to equivalent ages of 7 day is of more importance. This is what was found in the Phase 1 (laboratory study) of the overall research project (Section 3.4). The 14 and 28 day test results are still presented in the following sections to reconfirm that the maturity method does not always estimate the later-age strength accurately.

5.8.1.4.1 *Evaluation with Pullout Tests*

The first in-place testing that will be evaluated is the pullout test. Percent errors between the measured pullout strength and estimated strength from the laboratory S-M relationship are presented in Tables 5-40 and 5-41 for the cold-weather placement and warm-weather placement, respectively. In addition, the average absolute percent error between the in-place strength and strength estimated from the maturity method was calculated and is presented at the bottom of Tables 5-40 and 5-41. The estimated strengths from the laboratory S-M relationship that correspond to the each pullout testing

ages are presented in Appendix C. The 45°-line graphs, with ±15% error lines, that compare the measured pullout compressive strength to the estimated strength from the laboratory S-M relationship are shown in Figures 5-106 and 5-107. The Nurse-Saul maturity function with $T_o = 0$ °C and Arrhenius maturity function with $E = 33.5$ kJ/mol were both presented in this section in Figures 5-106 and 107, while the Nurse-Saul maturity function with $T_o = -10$ °C and Arrhenius maturity function with $E = 40$ kJ/mol are presented in Appendix C.

Table 5-40: Percent errors for pullout test using *laboratory* S-M relationship from the cold-weather placement

	Concrete Age (hours)	Insert Location	Nurse-Saul Function		Arrhenius Function	
			$T_o = -10$ °C	$T_o = 0$ °C	$E = 40$ kJ/mol	$E = 33.5$ kJ/mol
Percent Error	25.7	Top	-32%	-28%	-23%	-26%
		Side	-21%	-15%	-8%	-13%
		Bottom	-27%	-21%	-13%	-18%
	47.7	Top	-19%	-16%	-13%	-15%
		Side	-19%	-16%	-11%	-14%
		Bottom	-14%	-9%	-4%	-7%
	72.2	Top	-16%	-14%	-12%	-13%
		Side	-9%	-8%	-5%	-7%
		Bottom	-21%	-19%	-16%	-18%
	168.8	Top	-2%	-7%	-3%	-2%
		Side	-15%	-20%	-16%	-15%
		Bottom	-13%	-18%	-13%	-12%
	335.1	Top	-11%	-14%	-12%	-11%
		Side	-3%	-7%	-4%	-3%
		Bottom	16%	11%	14%	15%
	671.2	Top	18%	15%	16%	17%
		Side	11%	8%	10%	10%
		Bottom	16%	13%	15%	16%
Average Absolute % Error	Top	16%	16%	13%	14%	
	Side	13%	12%	9%	10%	
	Bottom	18%	15%	13%	14%	

Table 5-41: Percent errors for pullout test using *laboratory* S-M relationship from the warm-weather placement

	Concrete Age (hours)	Insert Location	Nurse-Saul Function		Arrhenius Function	
			T _o = -10 °C	T _o = 0 °C	E = 40 kJ/mol	E = 33.5 kJ/mol
Percent Error	24.0	Top	-17%	-13%	5%	-2%
		Side	-3%	1%	22%	14%
		Bottom	-18%	-14%	4%	-3%
	48.4	Top	6%	11%	31%	23%
		Side	-5%	0%	17%	10%
		Bottom	-3%	2%	20%	13%
	71.5	Top	2%	5%	17%	12%
		Side	4%	7%	20%	14%
		Bottom	4%	8%	21%	15%
	168.5	Top	4%	7%	13%	10%
		Side	19%	22%	29%	26%
		Bottom	16%	19%	27%	23%
	335.5	Top	9%	11%	16%	14%
		Side	25%	27%	33%	30%
		Bottom	0%	2%	6%	4%
	672.3	Top	0%	1%	5%	3%
		Side	-	-	-	-
		Bottom	16%	18%	22%	20%
Average Absolute % Error	Top	6%	8%	15%	11%	
	Side	11%	12%	24%	19%	
	Bottom	10%	10%	17%	13%	

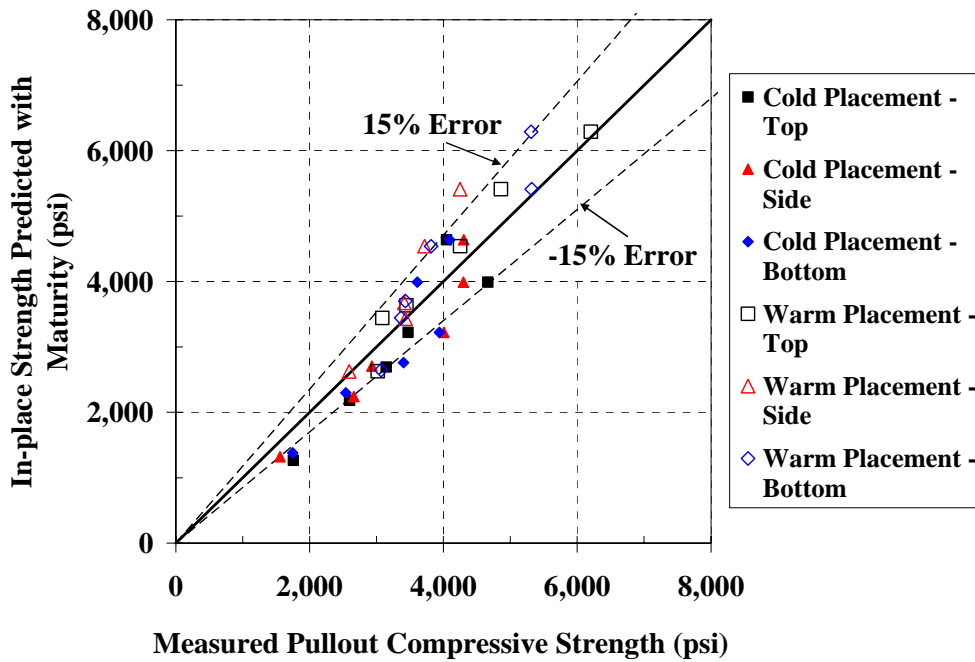

Figure 5-106: 45°-line graph for estimating the strength of pullout test on the mock bridge deck using *laboratory* S-M relationship with Nurse-Saul maturity function ($T_o = 0\text{ }^{\circ}\text{C}$)

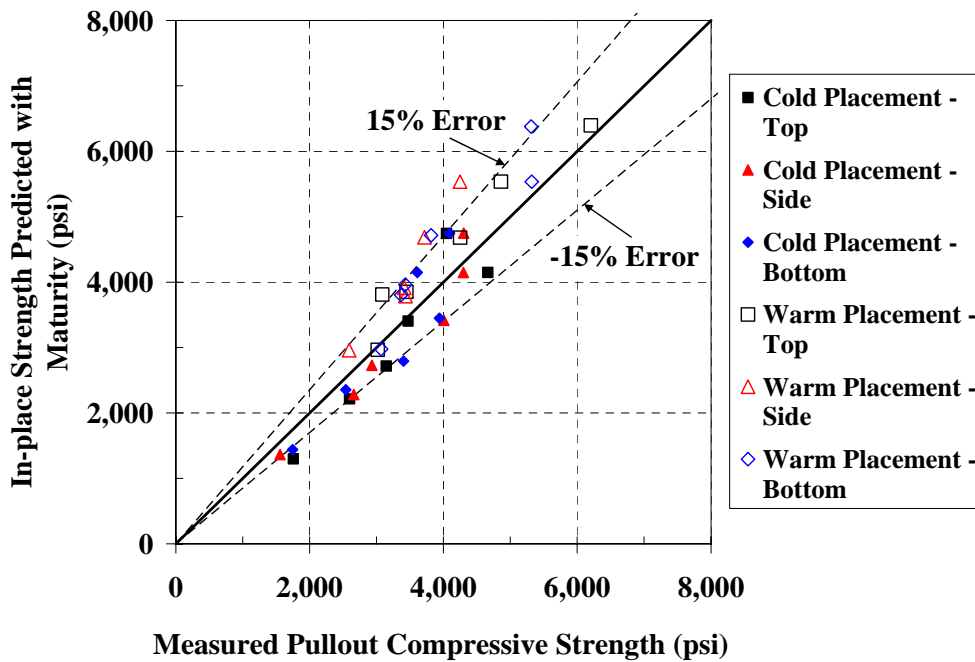

Figure 5-107: 45°-line graph for estimating the strength of pullout test on the mock bridge deck using *laboratory* S-M relationship with Arrhenius maturity function ($E = 33.5\text{ kJ/mol}$)

When considering the accuracy of the laboratory maturity functions to estimate the pullout strengths for the cold-weather placement, neither of the Nurse-Saul maturity functions estimated the in-place strength accurately. Most of the in-place strengths were underestimated. For the first four testing ages for cold-weather placement, the 15% limit was exceeded. In addition, the average absolute percent error for the cold-weather placement Nurse-Saul maturity function ranged from 12% to 18%. This indicates that the Nurse-Saul maturity function did not provide an accurate assessment of the in-place strength for the cold-weather placement. All of the percent errors were negative indicating that the strengths were underestimated, which is conservative. Nevertheless, the S-M maturity relationship from the laboratory-cured cylinders did not assess the in-place strength accurately.

For the warm-weather placement of the mock bridge deck, the Nurse-Saul maturity function estimated the in-place strength better than the Arrhenius maturity function. The Nurse-Saul maturity function with datum temperature 0 °C was within the 15% limit for the first three testing ages. The percent error only started to exceed the 15% limit at 7 days and beyond. The percent errors were as high as -18% for the first testing age using a datum temperature of -10 °C. All of the average absolute percent errors for the Nurse-Saul maturity function were below 12% for the warm-weather placement. This indicates that the Nurse-Saul maturity function developed from laboratory-cured cylinder was sufficiently accurate for estimating the in-place strength for the warm-weather placement of the mock bridge deck since a majority of the percent errors were below 15%.

When considering the Arrhenius maturity function laboratory-cured cylinders, it was more accurate at estimating the in-place strength than the Nurse-Saul maturity function for the cold-weather placement. The average absolute percent error for the *laboratory* S-M relationship developed with the Arrhenius maturity function for the cold-weather placement was within the 15% limit criteria. The activation energy of 40 kJ/mol provided a slightly more accurate estimation of strength than the activation energy of 33.5 kJ/mol. For the activation energy of 40 kJ/mol, a majority of percent errors were below the 15% limit with the exception of the 1-day top pullout test which was -23% and a limited number of other tests where the percent error was -16%. The 1-day top pullout test was not estimated correctly for any of the maturity functions which indicates that the test results might not have been accurate, especially when the side pullout was only 8% different for the activation energy of 40 kJ/mol. For the activation energy of 33.5 kJ/mol, the percent errors were slightly higher than activation energy of 40 kJ/mol for almost all of the pullout tests conducted on the cold-weather placement of the mock bridge deck. In general, the *laboratory* S-M relationship developed from the Arrhenius maturity function was accurate for estimating the cold-weather placement in-place strength; however, a few of percent errors did exceed the 15% limit.

In the warm-weather placement, the Arrhenius maturity function did not accurately assess the in-place strength. At activation energy of 40 kJ/mol, the 15% limit was exceeded for every testing age and the average absolute percent error ranged between 15% to 24%. These high errors indicate that the *laboratory* S-M relationship with activation energy of 40 kJ/mol does not accurately assess the warm-weather placement in-place strength of the concrete. For activation energy of 33.5 kJ/mol, the percent errors

were more accurate than activation energy of 40 kJ/mol, but still they exceeded the 15% limit for the 2- and 7-day testing ages. The average absolute percent error ranged from 11% to 19% for activation energy of 33.5 kJ/mol. While this error is better than activation energy of 40 kJ/mol, it still did not provide sufficiently accurate results.

The Nurse-Saul maturity function was the most accurate for estimating the in-place strength for the warm-weather placement using the *laboratory* S-M relationship. The Nurse-Saul maturity function with $T_o = 0$ °C estimated the early-age in-place strength slightly better than when $T_o = -10$ °C was used. The Arrhenius maturity function was most accurate at estimating the in-place strength of the cold-weather placement using the *laboratory* S-M relationship. The activation energy of 40 kJ/mol was slightly more accurate than activation energy of 33.5 kJ/mol. Since no maturity function provided an accurate estimate for both the cold- and warm-weather placements, this might indicate that the *laboratory* S-M relationships do not assess the in-place strength as accurately as needed. Therefore, the *water-tank* S-M relationships were evaluated to assess the in-place strength.

The in-place pullout strengths were evaluated using the *water-tank* S-M relationships. The percent errors and average absolute percent errors using the estimated strength from the *water-tank* S-M relationship for both cold and warm-weather placement are presented in Tables 5-42 and Table 5-43, respectively. The 45°-line graphs that show the measured in-place pullout compressive strength versus the estimated strengths from the *water-tank* S-M maturity relationship are presented in Figures 5-108 and 5-109. The Nurse-Saul maturity function with $T_o = 0$ °C and Arrhenius maturity function with $E =$

33.5 kJ/mol are presented in this section. The Nurse-Saul maturity functions with $T_0 = -10$ °C and Arrhenius maturity function with $E = 40$ kJ/mol are presented in Appendix C.

Table 5-42: Percent errors for pullout test using *water-tank* S-M relationship for the cold-weather placement

	Concrete Age (hours)	Insert Location	Nurse-Saul Function		Arrhenius Function	
			$T_0 = -10$ °C	$T_0 = 0$ °C	E = 40 kJ/mol	E = 33.5 kJ/mol
Percent Error	25.7	Top	-45%	-30%	-22%	-32%
		Side	-35%	-15%	-4%	-17%
		Bottom	-39%	-18%	-6%	-20%
	47.7	Top	-17%	3%	3%	-5%
		Side	-16%	3%	5%	-4%
		Bottom	-10%	11%	15%	4%
	72.2	Top	-9%	6%	4%	-2%
		Side	-2%	14%	13%	6%
		Bottom	-14%	0%	-1%	-6%
	168.8	Top	7%	12%	13%	10%
		Side	-7%	-3%	-2%	-4%
		Bottom	-6%	-1%	1%	-2%
	335.1	Top	-6%	-4%	-4%	-5%
		Side	2%	4%	4%	3%
		Bottom	22%	24%	24%	23%
	671.2	Top	18%	19%	19%	19%
		Side	11%	12%	12%	12%
		Bottom	17%	18%	18%	17%
Average Absolute % Error	Top	17%	12%	11%	12%	
	Side	12%	9%	7%	8%	
	Bottom	18%	12%	11%	12%	

Table 5-43: Percent errors for pullout test using *water-tank* S-M relationship for the warm-weather placement

	Concrete Age (hours)	Insert Location	Nurse-Saul Function		Arrhenius Function	
			T _o = -10 °C	T _o = 0 °C	E = 40 kJ/mol	E = 33.5 kJ/mol
Percent Error	24.0	Top	-24%	-20%	-4%	-10%
		Side	-11%	-7%	12%	5%
		Bottom	-24%	-21%	-5%	-11%
	48.4	Top	0%	5%	22%	15%
		Side	-10%	-6%	9%	3%
		Bottom	-8%	-4%	12%	5%
	71.5	Top	-3%	-1%	8%	4%
		Side	-2%	1%	11%	7%
		Bottom	-1%	1%	13%	8%
	168.5	Top	-1%	0%	5%	3%
		Side	13%	15%	20%	18%
		Bottom	10%	12%	18%	15%
	335.5	Top	2%	3%	7%	5%
		Side	17%	18%	22%	20%
		Bottom	-7%	-6%	-2%	-4%
	672.3	Top	-9%	-8%	-6%	-7%
		Side	-	-	-	-
		Bottom	7%	8%	10%	9%
Average Absolute % Error	Top	7%	6%	9%	7%	
	Side	10%	9%	15%	11%	
	Bottom	10%	9%	10%	9%	

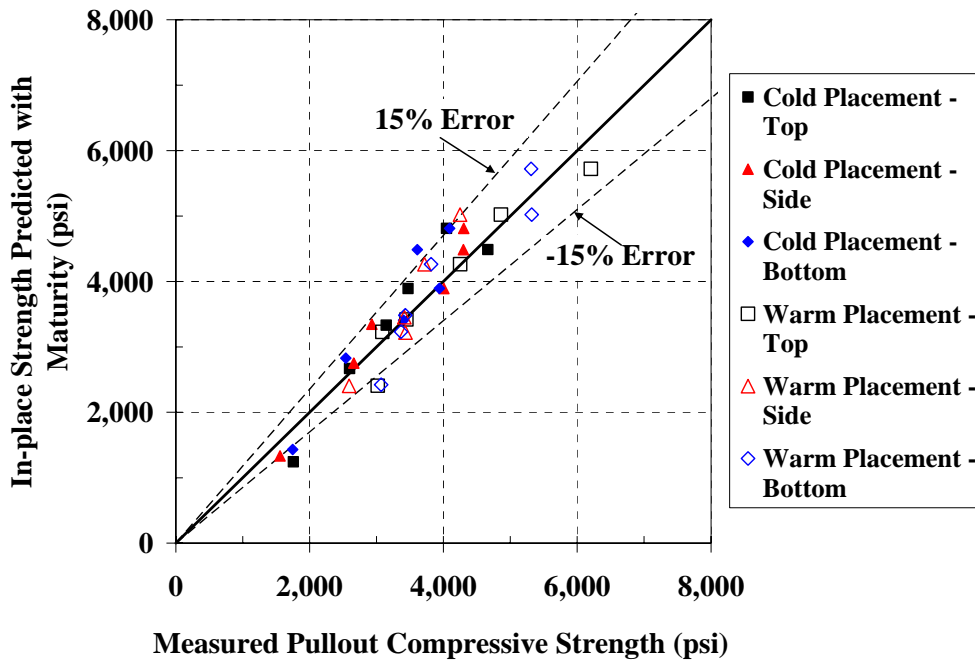

Figure 5-108: 45°-line graph for estimating the strength of pullout test on the mock bridge deck using *water-tank* S-M relationship with Nurse-Saul maturity function ($T_0 = 0\text{ }^{\circ}\text{C}$)

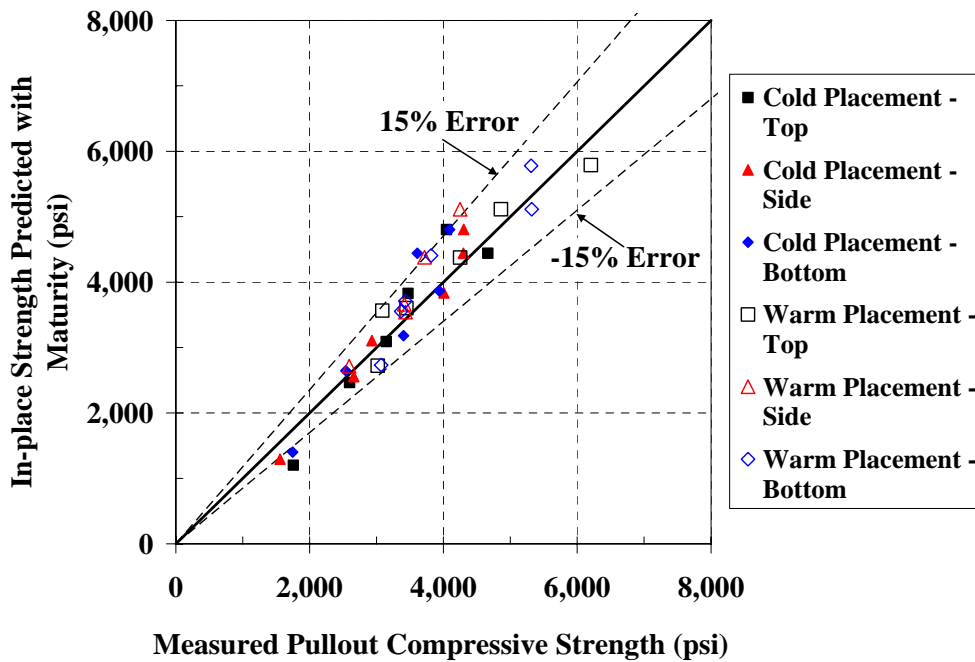

Figure 5-109: 45°-line graph for estimating the strength of pullout test on the mock bridge deck using *water-tank* S-M relationship with Arrhenius maturity function ($E = 33.5\text{ kJ/mol}$)

The cold-weather placement 1-day pullout test was higher than the estimated strength, which was the trend that also occurred in the *laboratory* S-M relationships. When evaluating the Nurse-Saul maturity functions the datum temperature of 0 °C was more accurate than the datum temperature of -10 °C for both placements of the mock bridge deck. The average absolute percent error ranged from 9% to 12% for the cold-weather placement and for the warm-weather placement ranged from 6% to 9%. For the cold and warm-weather placements, the only individual early-age percent errors that exceeded the 15% limit for $T_o = 0$ °C were for the 1-day testing age. The strengths for the 1-day testing ages were all negative, which means the strengths were underestimated. Considering this and that all other early-age testing was reasonably accurate, the $T_o = 0$ °C *water-tank* S-M relationship estimated the in-place strength with the acceptable tolerances. For Nurse-Saul maturity function with $T_o = -10$ °C, the average absolute percent error exceeded the 15% limit for the cold-weather placement and the errors were higher than those obtained when $T_o = 0$ °C was used for the warm-weather placement. This indicates that Nurse-Saul maturity function with $T_o = 0$ °C was the more accurate datum temperature for estimating the in-place strength using the *water-tank* S-M relationship.

For the Arrhenius maturity function, both activation energies provided approximately the same estimated accuracy for both the cold and warm-weather placement of the mock bridge deck. The activation energy of 40 kJ/mol was slightly more accurate at estimating all the strengths for the cold-weather placement than the activation energy of 33.5 kJ/mol. For concrete ages until 7 days, the only percent error for activation energy of 40 kJ/mol that exceeded the 15% limit for the cold-weather placement was the

1-day top pullout test. For the warm-weather placement, the activation energy of 33.5 kJ/mol was slightly more accurate for estimating the in-place strength. The only early-age error that exceeded the 15% limit for the early-age testing was the 7-day side pullout test.

When all the *water-tank* S-M relationships are considered, most of the percent errors are within the 15% range, and of the ones that were not within the 15% limit the strengths were mostly underestimated. Generally, the activation energies for the *water-tank* Arrhenius maturity functions were both similar in estimating the in-place strength of the concrete. On the other hand, the Nurse-Saul maturity function with $T_0 = 0\text{ }^{\circ}\text{C}$ estimated the strength more accurately than $T_0 = -10\text{ }^{\circ}\text{C}$. In addition, the average absolute percent errors for Nurse-Saul maturity function with $T_0 = 0\text{ }^{\circ}\text{C}$ were the lowest for the warm-weather placement and about the same as those obtained for the Arrhenius maturity function under cold-weather placement conditions. In general, for the *water-tank* S-M relationships using the Nurse-Saul maturity functions with $T_0 = 0\text{ }^{\circ}\text{C}$ were the most accurate for estimating the in-place pullout strength.

In summary, the *water-tank* S-M relationship was more accurate at estimating the pullout in-place strength of the concrete than the *laboratory* S-M relationship. The *laboratory* S-M relationship did not estimate the in-place strength accurately. The average absolute percent error ranges for the Nurse-Saul maturity function with $T_0 = 0\text{ }^{\circ}\text{C}$ ranged from 6% to 12% for the *water-tank* S-M relationship and 8% to 16% for the *laboratory* S-M relationship. The Nurse-Saul maturity function with $T_0 = 0\text{ }^{\circ}\text{C}$ using the *water-tank* S-M relationship tended to be the most accurate and conservative maturity function for estimating the strengths for both the cold and warm-weather placements of the mock bridge deck. The Arrhenius maturity function using activation energy of 40

kJ/mol was the best maturity function for estimating the cold-weather placement in-place strengths, but was the most inaccurate for estimating the in-place strength of the warm-weather placement. The Arrhenius maturity function with activation energy of 33.5 kJ/mol was the better activation energy for estimating the in-place strength. These results follow the conclusions that were found during Phase 1 (laboratory study) of the overall maturity project. The Nurse-Saul maturity function with $T_0 = 0$ °C was the most accurate for estimating the strength under all environmental conditions, whereas the higher activation energy was more accurate for estimating the colder placements and the lower activation energy was more accurate at estimating the warmer placements.

5.8.1.4.2 Evaluation with Cast-in-Place Cylinders

Next, the accuracy of the maturity method to estimate the compressive strength of the cast-in-place (CIP) cylinders was evaluated. If the CIP cylinders strengths were overestimated by more than 10%, then the maturity method was not considered accurate for estimating the in-place strength of the CIP cylinders. All estimated strength for the CIP cylinders from all four maturity functions and two different curing methods are presented in Appendix C.

The percent errors and average absolute percent errors for the CIP cylinder strength data using the *laboratory* S-M relationship are presented in Tables 5-44 and 5-45 for the cold and warm-weather placement, respectively. The 45°-line graphs that show the measured CIP cylinders strength versus the estimated strengths from the *laboratory* S-M maturity relationship for the Nurse-Saul maturity function with $T_0 = 0$ °C and

Arrhenius maturity function with $E = 33.5$ kJ/mol are presented in Figures 5-110 and 5-111. The 45°-line graphs for the Nurse-Saul maturity function with $T_o = -10$ °C and Arrhenius maturity function with $E = 40$ kJ/mol are presented Appendix C.

Table 5-44: Percent errors for CIP cylinder test using *laboratory* S-M relationship for the cold-weather placement

	Concrete Age (Days)	Nurse-Saul Function		Arrhenius Function	
		$T_o = -10$ °C	$T_o = 0$ °C	$E = 40$ kJ/mol	$E = 33.5$ kJ/mol
<i>Percent Error</i>	1.1	-28%	-23%	-14%	-19%
	2.1	-19%	-15%	-10%	-13%
	7.1	-10%	-14%	-10%	-9%
	28.0	-4%	-6%	-5%	-4%
<i>Average Absolute % Error</i>		15%	15%	10%	11%

Table 5-45: Percent errors for CIP cylinder test using *laboratory* S-M relationship for the warm-weather placement

	Concrete Age (Days)	Nurse-Saul Function		Arrhenius Function	
		$T_o = -10$ °C	$T_o = 0$ °C	$E = 40$ kJ/mol	$E = 33.5$ kJ/mol
<i>Percent Error</i>	1.0	-11%	-6%	17%	8%
	2.0	-9%	-4%	15%	8%
	7.1	2%	5%	14%	10%
	28.1	29%	31%	35%	33%
<i>Average Absolute % Error</i>		13%	11%	20%	15%

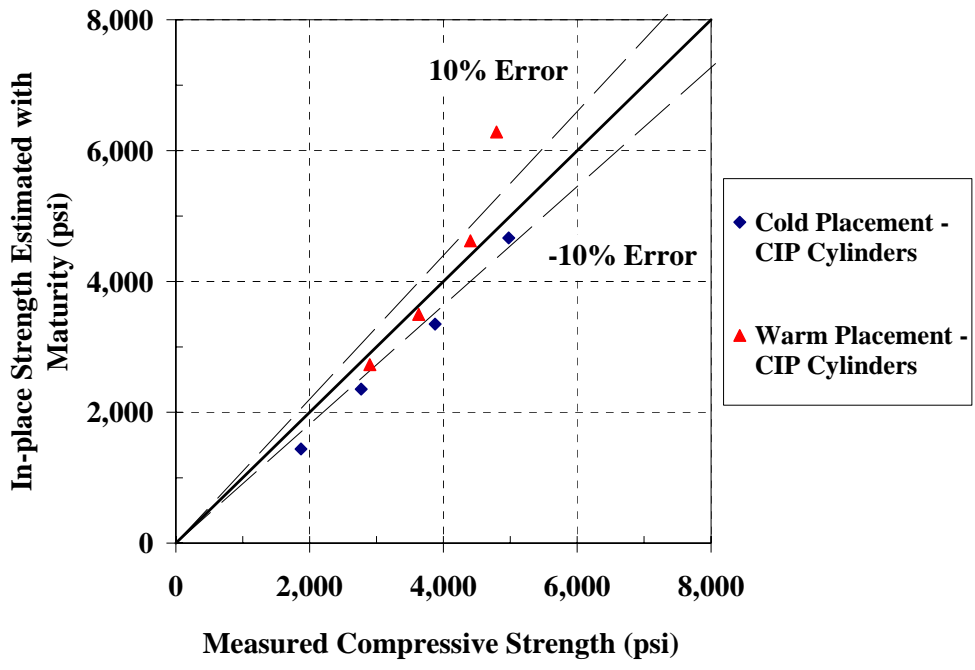

Figure 5-110: 45°-line graph for estimating the strength of CIP cylinders on the mock bridge deck using *Laboratory S-M* relationship with Nurse-Saul maturity function ($T_0 = 0\text{ }^\circ\text{C}$)

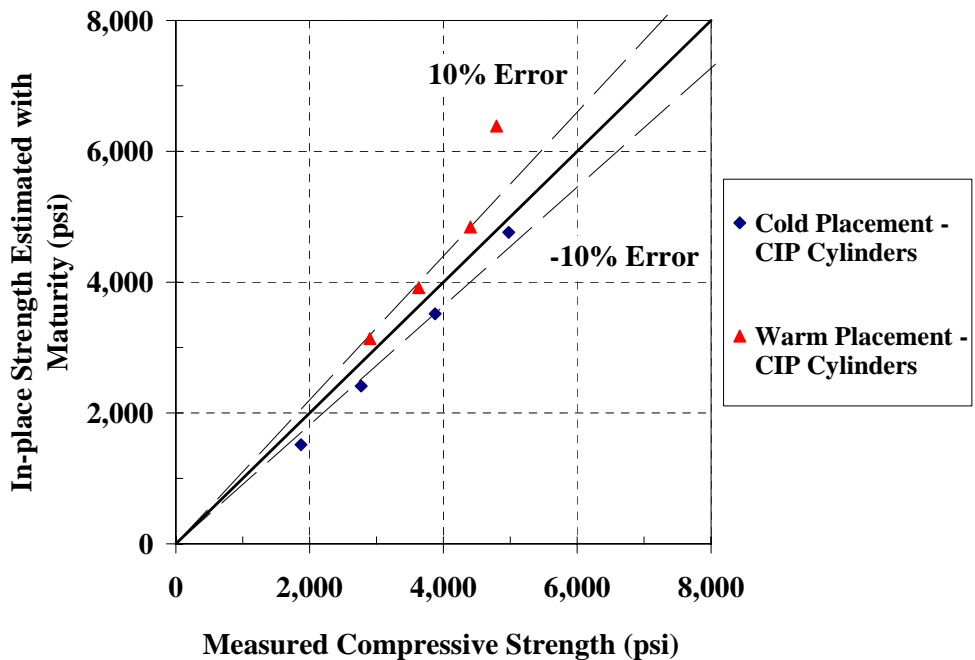

Figure 5-111: 45°-line graph for estimating the strength of CIP cylinders on the mock bridge deck using *Laboratory S-M* relationship with Arrhenius maturity function ($E = 33.5\text{ kJ/mol}$)

When evaluating the CIP cylinder strength data, the results of 28-day test for the warm-weather placement were extremely low. Difficulties occurred when removing the 28-day CIP cylinders from the mock bridge deck and this can probably explain this low strength. In addition, since the maturity method is more useful for early-age estimations the 28-day test results for the warm-weather placement will not be considered further. For evaluating the *laboratory* S-M relationships, the cold-weather placement CIP cylinders strengths were not estimated accurately for any of the maturity functions. All of the estimated strengths were underestimated by more than 10% with exception of the 28-day test and 7-day test for activation energy of 33.5 kJ/mol. The average absolute percent errors ranged between 10% and 15% for the cold-weather placement.

For the warm-weather placement data, the *laboratory* S-M relationship using the Nurse-Saul maturity function with $T_o = 0$ °C was the most accurate of all the maturity functions for estimating the in-place strength. For concrete ages until 7 days, the percent errors ranged from -6% to 5% for Nurse-Saul maturity function with $T_o = 0$ °C. In addition, the Arrhenius maturity function with activation energy of 33.5 kJ/mol was more accurate than the activation energy of 40 kJ/mol at estimating the in-place strength. The percent errors for the early-age testing ranged between 8% and 10%, which was much lower than the range of 14% to 17% for activation energy of 40 kJ/mol. Again, like the pullout test, there was no one *laboratory* S-M relationship that accurately assessed the in-place strength for both placements of the mock bridge deck. The *water-tank* S-M relationships were evaluated next to determine if the *water-tank* S-M relationships estimated the in-place strength more accurately.

The percent errors and average absolute percent errors for the CIP cylinder strength data using the *water-tank* S-M relationship are presented in Tables 5-46 and 5-47 for the cold and warm-weather placement, respectively. The 45°-line graphs that show the measured CIP cylinder strength versus the estimated strengths from the *water-tank* S-M maturity relationship for the Nurse-Saul maturity function with $T_o = 0\text{ }^{\circ}\text{C}$ and Arrhenius maturity function with $E = 33.5\text{ kJ/mol}$ are presented in Figures 5-112 and 5-113. The 45°-line graphs for the Nurse-Saul maturity function with $T_o = -10\text{ }^{\circ}\text{C}$ and Arrhenius maturity function with $E = 40\text{ kJ/mol}$ are presented Appendix C.

Table 5-46: Percent errors for CIP cylinder test using *water-tank* S-M relationship for the cold-weather placement

	Concrete Age (Days)	Nurse-Saul Function		Arrhenius Function	
		$T_o = -10\text{ }^{\circ}\text{C}$	$T_o = 0\text{ }^{\circ}\text{C}$	$E = 40\text{ kJ/mol}$	$E = 33.5\text{ kJ/mol}$
Percent Error	1.1	-40%	-18%	-6%	-19%
	2.1	-14%	5%	7%	-2%
	7.1	-2%	3%	4%	1%
	28.0	-4%	-3%	-3%	-3%
Average Absolute % Error		15%	7%	5%	6%

Table 5-47: Percent errors for CIP cylinder test using *water-tank* S-M relationship for the warm-weather placement

	Concrete Age (Days)	Nurse-Saul Function		Arrhenius Function	
		$T_o = -10\text{ }^{\circ}\text{C}$	$T_o = 0\text{ }^{\circ}\text{C}$	$E = 40\text{ kJ/mol}$	$E = 33.5\text{ kJ/mol}$
Percent Error	1.0	-17%	-13%	8%	0%
	2.0	-13%	-10%	7%	1%
	7.1	-3%	-1%	6%	3%
	28.1	19%	19%	22%	21%
Average Absolute % Error		13%	11%	11%	6%

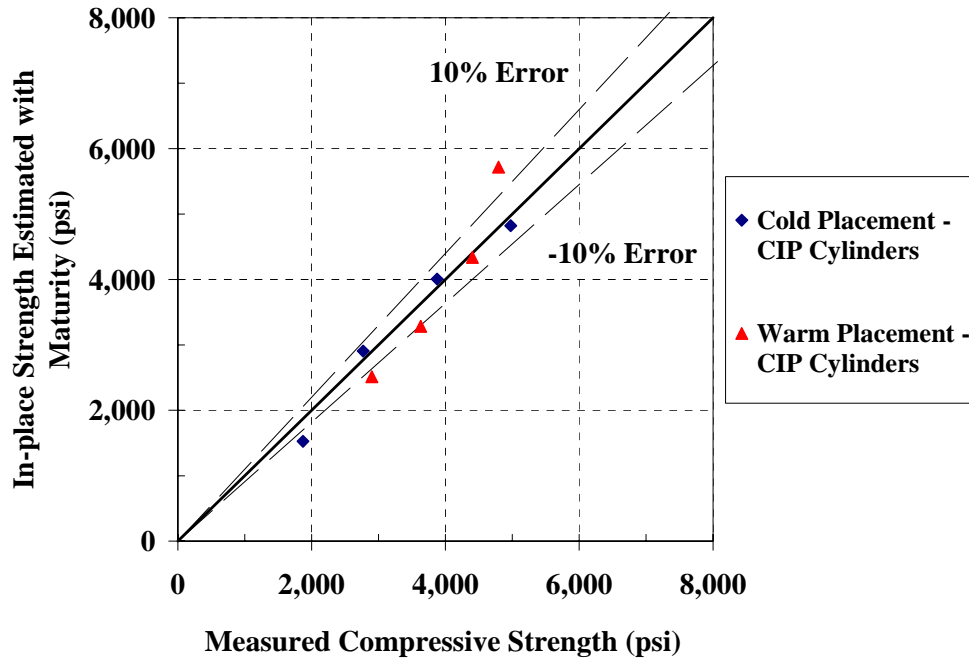

Figure 5-112: 45°-line graph for estimating the strength of CIP cylinders on the mock bridge deck using *water-tank* S-M relationship with Nurse-Saul maturity function ($T_o = 0\text{ }^\circ\text{C}$)

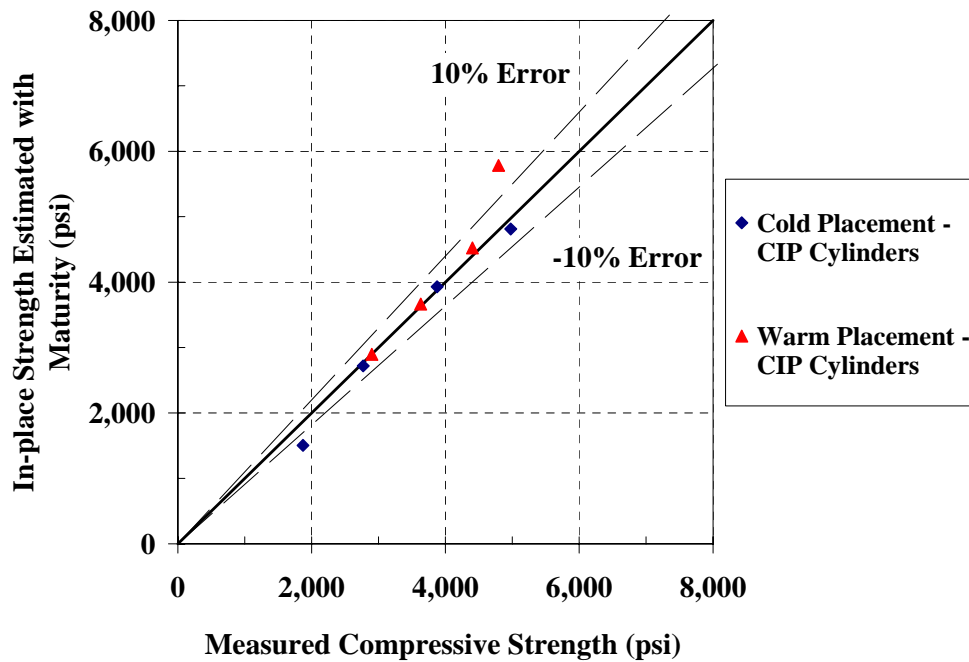

Figure 5-113: 45°-line graph for estimating the strength of CIP cylinders on the mock bridge deck using *water-tank* S-M relationship with Arrhenius maturity function ($E = 33.5\text{ kJ/mol}$)

The accuracy of the *water-tank* S-M relationships for the cold-weather placement to estimate the strength of the CIP cylinders was more accurately than the *laboratory* S-M relationship. The Arrhenius maturity function with $E = 40$ kJ/mol was the most accurate with the percent error never higher than 7%. For activation energy of 33.5 kJ/mol, the 2-, 7- and 28-day percent errors were between -3% and 1%, but the 1-day percent error was -19%. For the Nurse-Saul maturity function, again the datum temperature of 0 °C was more accurate than the datum temperature of -10 °C. The average absolute error was 7% for Nurse-Saul maturity function with $T_0 = 0$ °C and 15% for $T_0 = -10$ °C. The single highest error determined was for the 1-day test for the cold-weather placement, which was -18%. This is out of the 10% limit, but this negative indicates that the strength is underestimated, which is conservative.

For the warm-weather placement, the *water-tank* S-M relationship was again more accurate than the *laboratory* S-M relationship. The Arrhenius maturity function with $E = 33.5$ kJ/mol was the most accurate for all the maturity functions. The average absolute error was 6%, versus 11% for the activation energy of 40 kJ/mol and datum temperature of 0 °C. Although it should be noted if the 28-day test results were removed as discussed earlier, the average absolute percent error would be improved. For the Nurse-Saul maturity function with $T_0 = 0$ °C, the 1-day test age exceeded the 10% limit with a percent error of -13%. This again is a negative error, which indicates that the strength is underestimated. The datum temperature -10 °C was again the most inaccurate for estimating the in-place strength for the warm-weather placement. All but the 7-day testing age exceeded the 10% limit.

In summary, the *water-tank* S-M relationship was more accurate in estimating the in-place strength than the *laboratory* S-M relationship. When comparing the two activation energies, $E = 40$ kJ/mol was more accurate for the cold-weather placement and 33.5 kJ/mol was more accurate for the warm-weather placement. The datum temperature of 0 °C was more accurate than datum temperature of -10 °C for both placements. The only case where the error for the datum temperature of 0 °C exceeded 10% for the *water-tank* S-M relationships was for the 1-day testing age, but in both placements the strength was underestimated, which is conservative.

5.8.1.4.3 Evaluation with Core Strengths

Finally, the accuracy of the maturity method to estimate the compressive strength of cores was evaluated. As stated in Section 5.5.6, if the core strength results are less than 15% less than the strength estimated by the maturity method, then the maturity method will not be considered accurate for estimating the in-place strength of cores. All estimated strengths for from the four maturity methods and two curing methods are presented in Appendix C.

The percent errors and average absolute percent errors for the core strength data using the *laboratory* S-M relationship are presented in Table 5-48 and 5-49 for the cold and warm-weather placement, respectively. The 45°-line graphs that show the measured core strength versus the estimated strengths from the *laboratory* S-M maturity relationship for the Nurse-Saul maturity function with $T_o = 0$ °C and Arrhenius maturity function with $E = 33.5$ kJ/mol are presented in Figures 5-114 and 5-115. The 45°-line

graphs for the Nurse-Saul maturity function with $T_o = -10\text{ }^\circ\text{C}$ and Arrhenius maturity function with $E = 40\text{ kJ/mol}$ are presented in Appendix C.

Table 5-48: Percent errors for core tests using *laboratory* S-M relationship for the cold-weather placement

	Concrete Age (Days)	Curing Method	Nurse-Saul Function		Arrhenius Function	
			$T_o = -10\text{ }^\circ\text{C}$	$T_o = 0\text{ }^\circ\text{C}$	$E = 40\text{ kJ/mol}$	$E = 33.5\text{ kJ/mol}$
<i>Percent Error</i>	10.2	ASTM C 42	1%	1%	2%	2%
		AASHTO T 24	3%	3%	4%	4%
	30.0	ASTM C 42	4%	2%	3%	4%
		AASHTO T 24	13%	11%	12%	13%
<i>Average Absolute % Error</i>		ASTM C 42	3%	2%	3%	3%
		AASHTO T 24	8%	7%	8%	8%

Table 5-49: Percent errors for core tests using *laboratory* S-M relationship for the warm-weather placement

	Concrete Age (Days)	Curing Method	Nurse-Saul Function		Arrhenius Function	
			$T_o = -10\text{ }^\circ\text{C}$	$T_o = 0\text{ }^\circ\text{C}$	$E = 40\text{ kJ/mol}$	$E = 33.5\text{ kJ/mol}$
<i>Percent Error</i>	7.1	ASTM C 42	33%	35%	47%	42%
		AASHTO T 24	38%	40%	53%	47%
	28.1	ASTM C 42	52%	53%	58%	56%
		AASHTO T 24	52%	54%	58%	56%
<i>Average Absolute % Error</i>		ASTM C 42	42%	44%	53%	49%
		AASHTO T 24	45%	47%	55%	52%

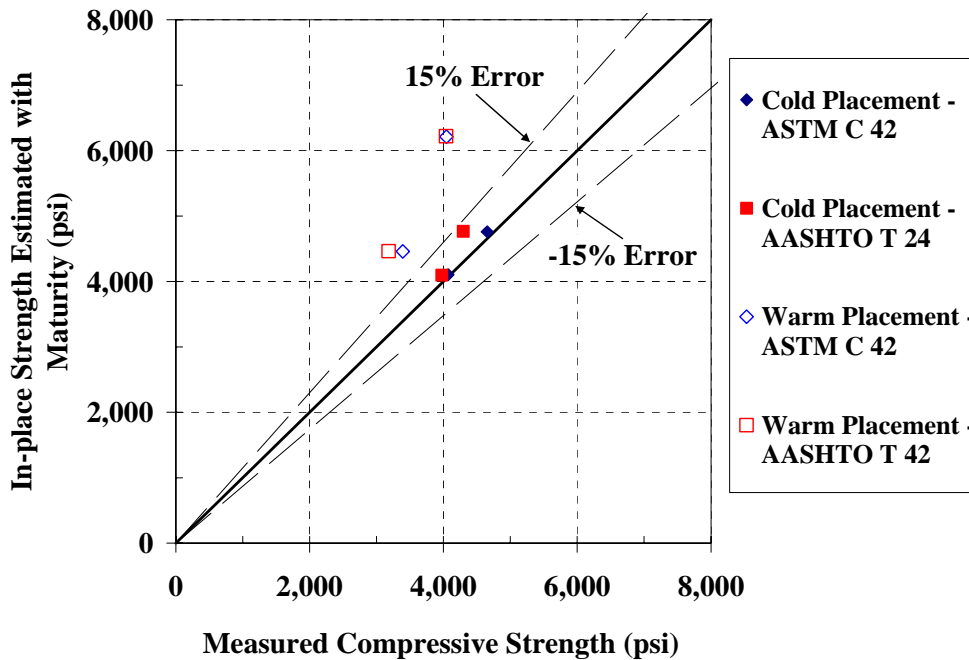

Figure 5-114: 45°-line graph for estimating the strength of cores for the mock bridge deck using *laboratory* S-M relationship with Nurse-Saul maturity function ($T_0 = 0\text{ }^\circ\text{C}$)

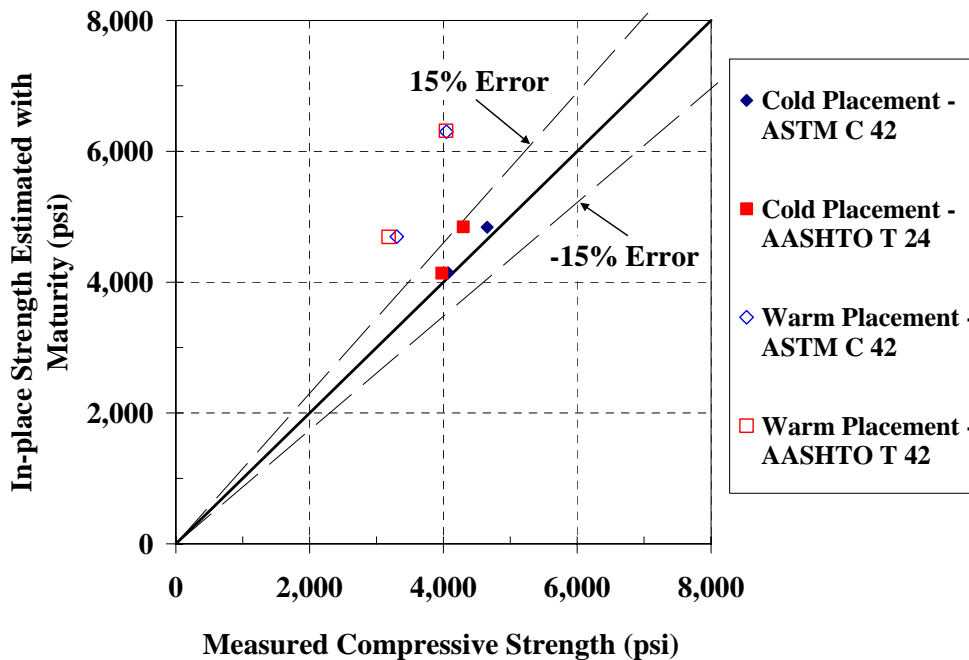

Figure 5-115: 45°-line graph for estimating the strength of cores for the mock bridge deck using *laboratory* S-M relationship with Arrhenius maturity function ($E = 33.5\text{ kJ/mol}$)

All four maturity functions estimated all of the core strengths within the 15% limit for the cold-weather placement but were all overestimated by the *laboratory* S-M relationships. In fact, all of the maturity functions estimated the strengths approximately the same. The average absolute percent errors were approximately 3% for the ASTM C 24 curing method and 8% for the AASHTO T 42 curing method. On the other hand, none of the maturity functions estimated the strength of the cores accurately for the warm-weather placement. The percent errors ranged from 33% to 58%, which indicates that the *laboratory* S-M relationship overestimated the strength of the cores by a substantial amount.

The strength data of the cores was also compared to the estimated strengths from the *water-tank* S-M relationship to see if they would provide a better estimate of in-place strength. The percent errors for the *water-tank* S-M relationships for both the cold and warm-weather placement are presented in Tables 5-50 and 5-51. The 45°-line graphs that show the measured core strength versus the estimated strengths from the *water-tank* S-M maturity relationship for the Nurse-Saul maturity function with $T_0 = 0\text{ }^{\circ}\text{C}$ and Arrhenius maturity function with $E = 33.5\text{ kJ/mol}$ are presented in in Figures 5-116 and 5-117. The 45°-line graphs for $T_0 = -10\text{ }^{\circ}\text{C}$ and $E = 40\text{ kJ/mol}$ are presented in Appendix C along with the estimated strengths of all the maturity functions for the core tests.

Table 5-50: Percent errors for core tests using *water-tank* S-M relationship for the cold-weather placement

	Concrete Age (Days)	Curing Method	Nurse-Saul Function		Arrhenius Function	
			T _o = -10 °C	T _o = 0 °C	E = 40 kJ/mol	E = 33.5 kJ/mol
<i>Percent Error</i>	10.2	ASTM C 42	7%	12%	11%	9%
		AASHTO T 24	9%	14%	13%	11%
	30.0	ASTM C 42	4%	5%	5%	4%
		AASHTO T 24	13%	13%	13%	13%
<i>Average Absolute % Error</i>		ASTM C 42	5%	8%	8%	7%
		AASHTO T 24	11%	14%	13%	12%

Table 5-51: Percent errors for core tests using *water-tank* S-M relationship for the warm-weather placement

	Concrete Age (Days)	Curing Method	Nurse-Saul Function		Arrhenius Function	
			T _o = -10 °C	T _o = 0 °C	E = 40 kJ/mol	E = 33.5 kJ/mol
<i>Percent Error</i>	7.1	ASTM C 42	26%	27%	37%	33%
		AASHTO T 24	31%	32%	42%	38%
	28.1	ASTM C 42	39%	40%	42%	41%
		AASHTO T 24	40%	40%	43%	42%
<i>Average Absolute % Error</i>		ASTM C 42	33%	33%	39%	37%
		AASHTO T 24	35%	36%	42%	40%

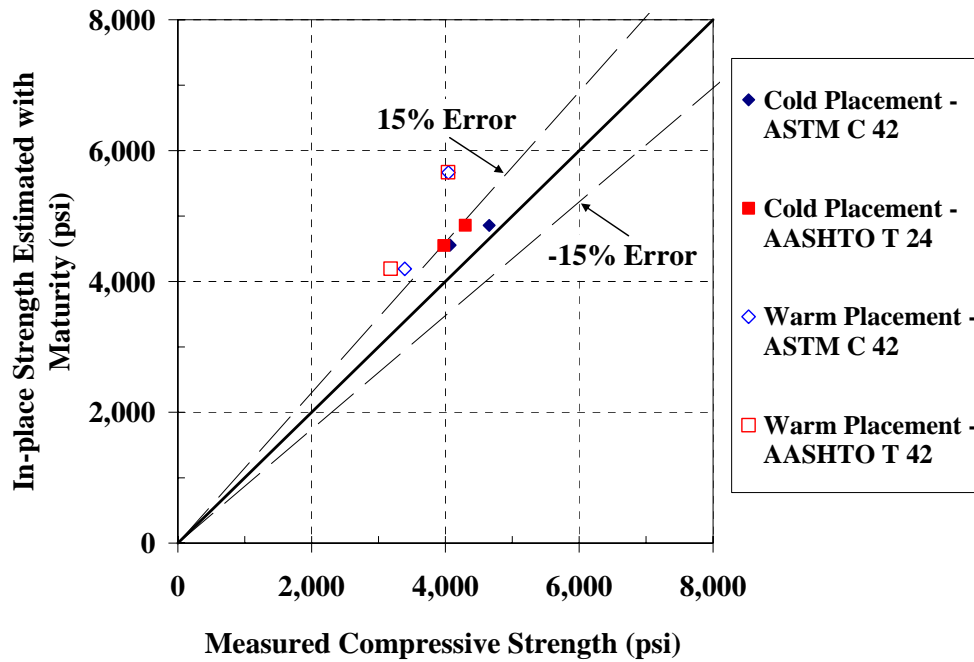

Figure 5-116: 45°-line graph for estimating the strength of cores for the mock bridge deck using *water-tank* S-M relationship with Nurse-Saul maturity function ($T_0 = 0\text{ }^{\circ}\text{C}$)

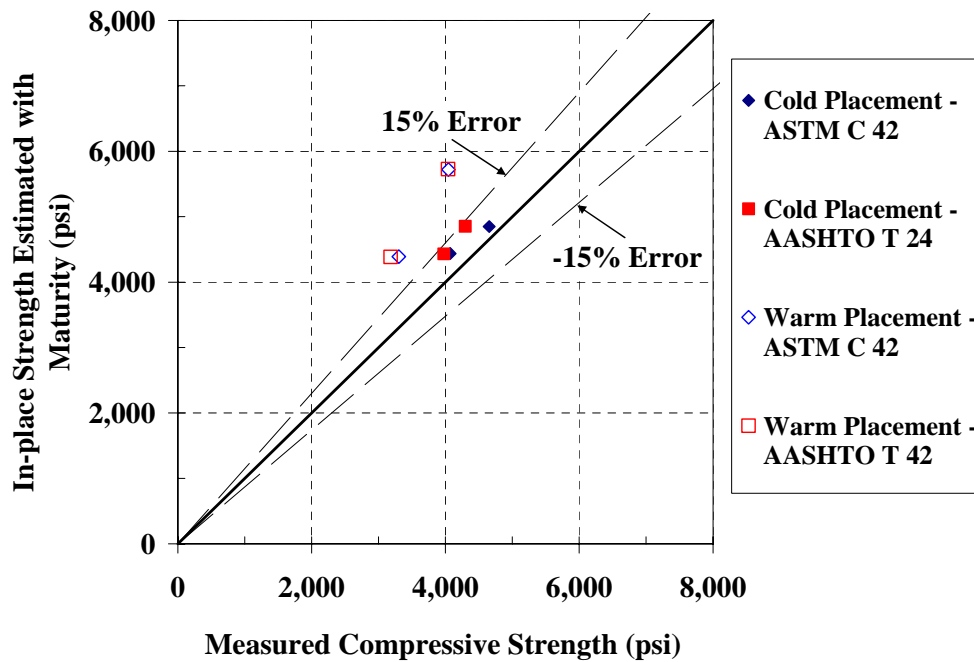

Figure 5-117: 45°-line graph for estimating the strength of cores for the mock bridge deck using *water-tank* S-M relationship with Arrhenius maturity function ($E = 33.5\text{ kJ/mol}$)

Again, the same trends that occurred for laboratory-cured cylinder results can be identified for the water-tank-cured cylinder results. All of the percent errors for the cold-weather placement were within the 15% limit with the largest one being 14%. The datum temperature of $-10\text{ }^{\circ}\text{C}$ was the most accurate maturity function with an average absolute error of 5% for ASTM C 24 curing method and 11% for AASHTO T 24 curing method. The average absolute errors for the Nurse-Saul maturity function with $T_0 = 0\text{ }^{\circ}\text{C}$ were 8% for ASTM C 24 curing method and 14% for the AASHTO T 24 curing method. For the warm-weather placement, the core strengths were overestimated by a minimum of 26% for all methods. This same trend occurred in the *laboratory* S-M relationships. None of the maturity functions could estimate the cores strengths accurately for the warm-weather placement.

For the differences in the two core curing methods, the ASTM C 24 curing method had lower average absolute percent errors than the AASHTO T 42 curing method. On average, it was 5% lower for the cold-weather placement and 3% lower for the warm-weather placement. This would indicate that the ASTM C 24 curing method was slightly better than the AASHTO T 42 curing method, but not enough evidence is present to conclude which method is better. In fact, the strengths for the two different curing methods were very close, as can be seen in Figures 5-116 and 5-117.

5.8.1.4.4 Comparison of In-Place Testing Results

A comparison of the compressive strength of the pullout test and the compressive strength of the CIP cylinder to the cores can be seen in Figure 5-118 and 5-119 for the cold- and warm-weather placement, respectively. The 7- and 28-day testing ages are shown for all test types. The maturities for the pullout test, CIP cylinders and cores were not exactly the same but were within approximately 10% of one another. The strength from the compression testing of the cores did not correspond well to the compression strength of the pullout test and CIP cylinders at the same ages for the warm-weather placement of the mock bridge deck. The core strengths were lower for the warm-weather placement.

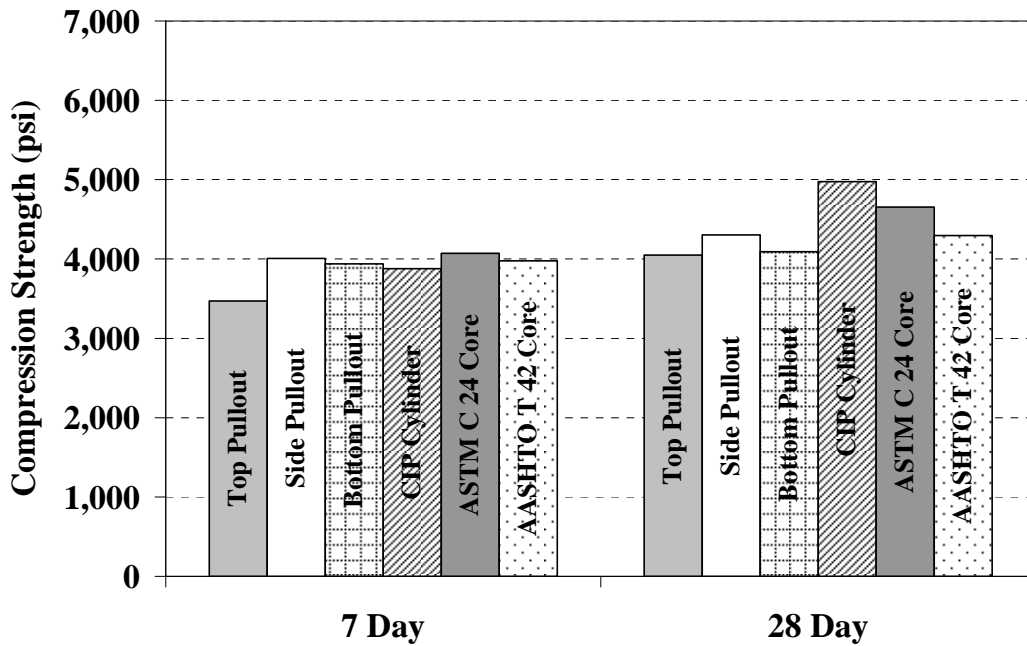

Figure 5-118: Compression strength of the pullout test and CIP Cylinder versus the cores for the cold-weather placement 7- and 28-day testing ages

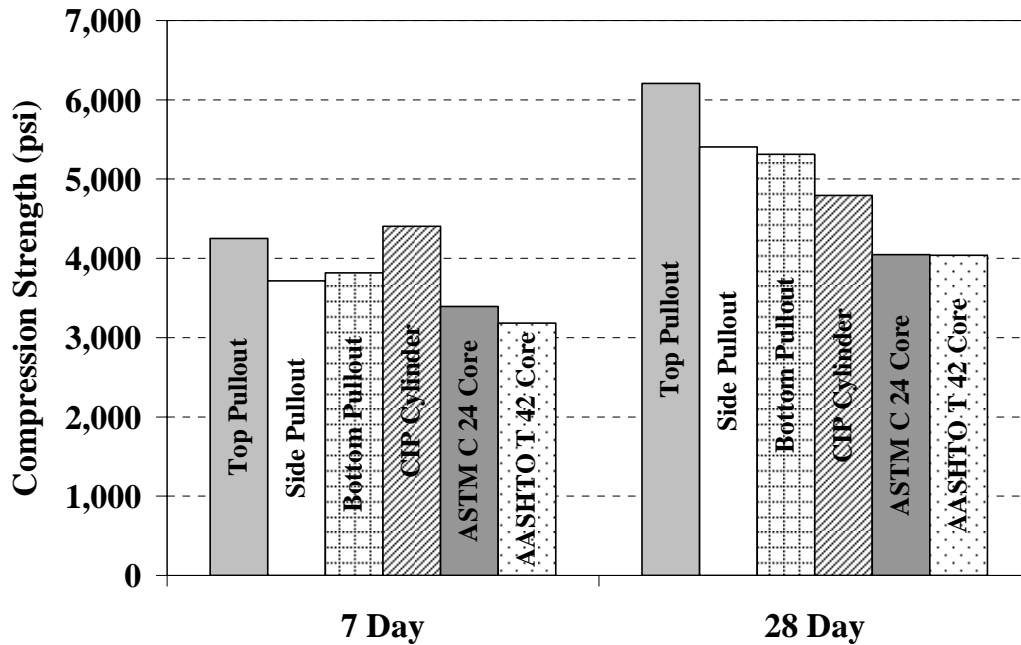

Figure 5-119: Compression strength of the pullout test and CIP Cylinder versus the cores for the warm-weather placement 7- and 28-day testing ages

The fact that the maturity method worked for cold-weather placement and not for the warm-weather placement indicates that the strength of the cores were not well estimated. However, this does not mean that the maturity method did not work well. The discrepancies between the cold-weather cores strength and the pullout test results tends to indicate that the warm-weather core strengths were most likely lower than the actual in-place strengths. Since there is such a large discrepancy between the cold and warm-weather placement data a conclusion could not be drawn on whether the *laboratory* cured S-M relationship or *water-tank* S-M relationship was more accurate for estimating the core strengths.

5.8.1.4.5 Summary

In summary, the *water-tank* S-M relationship provided a more accurate estimate of the in-place strength as measured by pullout testing and compression testing of cast-in-place cylinder than did the *laboratory* S-M relationship. The compressive strength of the cores was only estimated well by the maturity method for the cold-weather placement of the mock bridge deck. This discrepancy between the cold and warm-weather placement was probably caused by the core strength being lower for the warm-weather placement.

Therefore, due to the low performance of the cores, the agreement with the results from the prestressed plant project, and that the results agree with the other researchers' opinions about the compressive strength of cores not being an accurate assessment of in-place strength, the inaccuracy of core results were not strongly considered when evaluating the ability of the maturity method to estimate the in-place strength of concrete.

Final evaluations of the different maturity method used to assess the in-place strength indicate that the Nurse-Saul maturity function with $T_0 = 0\text{ }^{\circ}\text{C}$ was more accurate at estimating the early-age in-place strength. The Nurse-Saul maturity function with $T_0 = -10\text{ }^{\circ}\text{C}$ seemed to inaccurately estimate the in-place strength for both the pullout test and compressive strength of the cast-in-place cylinders. The datum temperature of $0\text{ }^{\circ}\text{C}$ seemed to estimate the in-place strength the most accurate when considering both cold and warm-weather placement and both the pullout test and compressive strength testing of the cast-in-place cylinders. The few times that the datum temperature of $0\text{ }^{\circ}\text{C}$ exceeded the limits for assessing the accuracy, it underestimated the strength at the first testing ages. This underestimation of the strength is conservative, and the strength developed at

that time is so rapid that difference strength at those ages is much smaller than the difference in strength at later ages, such as 3 and 7 day testing ages.

For the Arrhenius maturity function, an activation energy of 33.5 kJ/mol provided more accurate estimates of the in-place strength under the warm-weather placement and the activation energy of 40 kJ/mol provided more accurate estimate of the in-place strength under cold-weather placement. The Nurse-Saul maturity function was the most accurate for using the same maturity function to estimate the in-place strength for either the cold or warm-weather placement.

5.8.2 ACCURACY OF THE USE OF MOLDED CYLINDERS FOR STRENGTH

VERIFICATION TESTING

This section is devoted to evaluating the accuracy of the use of molded cylinders for verification testing as recommended by ASTM C 1074 in Section 9.5.4. First, the *Creek Bridge* S-M relationship cylinders will be compared to the *I-85 Bridge* S-M relationship. The *I-85 Bridge* S-M relationship will be used for the evaluation of the all verification tests.

5.8.2.1 Assessing the I-85 Bridge S-M Relationship

Before the accuracy of the maturity method could be assessed, the *I-85 Bridge* S-M relationship was checked to evaluate the fit of the S-M relationship to the strength and maturity data of the I-85 D cylinders. The percent errors at each testing age and average absolute error for the entire set were calculated using the strengths from *I-85 Bridge* S-M relationship that corresponded to the measured strengths of the I-85 D cylinders at the

same maturity and are presented in Table 5-52. The percent errors were calculated using Equation 4-1, and the average absolute errors were calculated using Equation 4-2. If the percent error is negative, then the maturity method underestimates the strength, and if the error is positive, then the maturity method overestimates the strength. As long as the maturity method does not overestimate the strength by more than 10%, then the maturity method will be considered accurate to estimate the strength of the molded cylinders.

Table 5-52: Evaluation of the errors of the I-85 S-M relationship I-85 D cylinders

	Concrete Age (hours)	Nurse-Saul Function		Arrhenius Function	
		$T_o = -10\text{ }^\circ\text{C}$	$T_o = 0\text{ }^\circ\text{C}$	$E = 33.5$ kJ/mol	$E = 40$ kJ/mol
<i>Percent Error</i>	24.0	11%	10%	10%	10%
	47.9	-3%	-3%	-3%	-3%
	77.0	-2%	-2%	-2%	-2%
	103.5	-3%	-3%	-3%	-3%
	172.1	2%	2%	2%	2%
	339.8	4%	4%	4%	4%
	680.6	-2%	-2%	-2%	-2%
<i>Average Absolute Error (psi)</i>		151	147	148	146

- Negative percent error reflects an underestimation of the measured strength

+ Positive percent error reflects an overestimation of the measures strength

The average absolute error ranged from 146 to 151 psi for the I-85 D set of cylinders. This indicates that all of the maturity methods fit the I-85 D cylinder strength data well. The only percent error that was high was the 1-day testing age for the I-85 D cylinder using the Nurse-Saul maturity function with a $T_o = -10\text{ }^\circ\text{C}$. The percent errors for the Nurse-Saul maturity function with $T_o = 0\text{ }^\circ\text{C}$ and the Arrhenius maturity function with $E = 33.5\text{ kJ/mol}$ and 40 kJ/mol were all at 10% which is the maximum limit for not

being accurate. Since no other percent error exceeds 4%, the *I-85 Bridge S-M* relationship will be considered a good fit for all maturity.

The average absolute errors and percent errors at each testing age were calculated to compare the estimated strength from the *I-85 Bridge S-M* relationship to the measured strength of the Creek A cylinders. The average absolute errors and percent error are presented in Tables 5-53. The estimated strengths from the *I-85 Bridge S-M* relationship for Creek A cylinders are presented in Appendix C. The estimated strengths from the *I-85 Bridge S-M* relationship and the corresponding measured strengths for the Creek A cylinders are presented in Figure 5-120 to 5-123. A 45°-line was plotted on the graphs to illustrate where the estimated strengths versus measured strengths are equal. In addition, $\pm 10\%$ error lines are added to the plots to show the magnitude of the error. If the error was negative, then the maturity method underestimated the strength (which is conservative), and if the error was positive then the maturity method overestimated the strength.

Table 5-53: Percent errors for Creek A cylinder data using *I-85 Bridge S-M* relationships

	Concrete Age (hours)	Nurse-Saul Function		Arrhenius Function	
		T _o = -10 °C	T _o = 0 °C	E = 33.5 kJ/mol	E = 40 kJ/mol
<i>Percent Error</i>	24.6	-19%	-11%	-6%	-4%
	48.5	-16%	-12%	-11%	-9%
	-	-	-	-	-
	93.7	-6%	-5%	-4%	-3%
	168.9	2%	3%	3%	4%
	333.0	1%	1%	1%	2%
	668.3	-4%	-4%	-4%	-4%
<i>Average Absolute Error (psi)</i>		288	231	205	186

- Negative percent error reflects an underestimation of the measured strength

+ Positive percent error reflects an overestimation of the measures strength

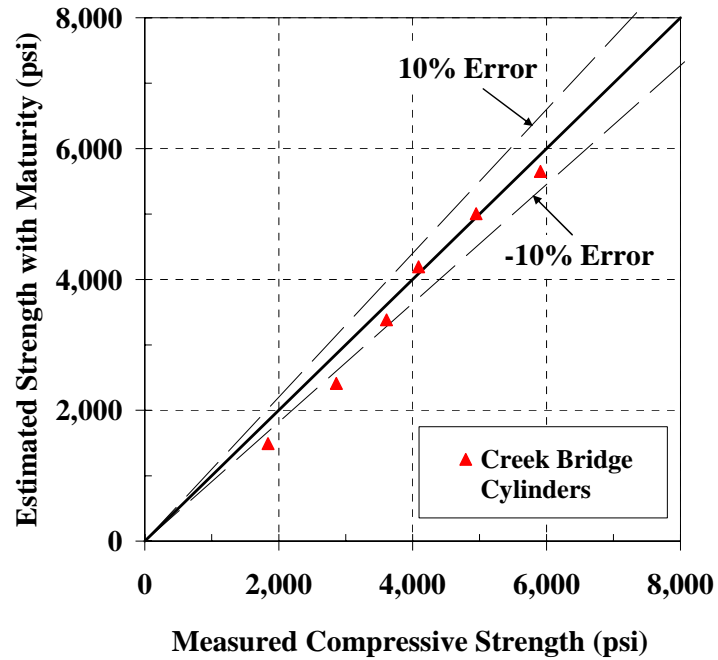

Figure 5-120: 45°-line graph for estimating the strength of the Creek A cylinders using *I-85 Bridge S-M relationship with Nurse-Saul maturity function ($T_0 = -10\text{ }^{\circ}\text{C}$)*

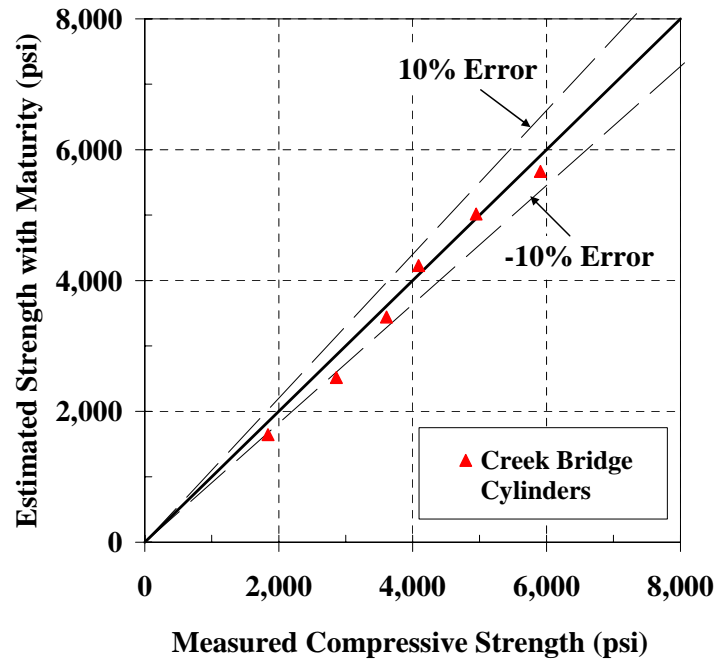

Figure 5-121: 45°-line graph for estimating the strength of the Creek A cylinders using *I-85 Bridge S-M relationship with Nurse-Saul maturity function ($T_0 = 0\text{ }^{\circ}\text{C}$)*

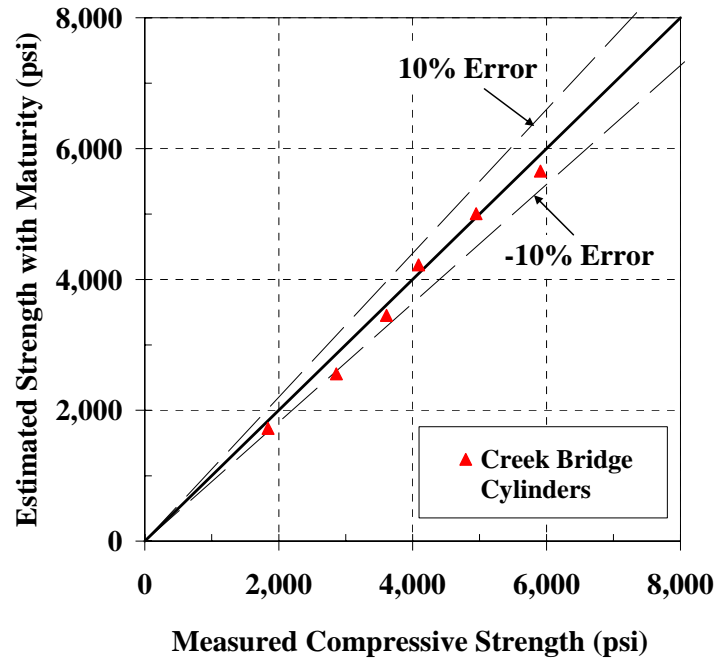

Figure 5-122: 45°-line graph for estimating the strength of the Creek A cylinders using *I-85 Bridge S-M* relationship with Arrhenius maturity function ($E = 33.5$ kJ/mol)

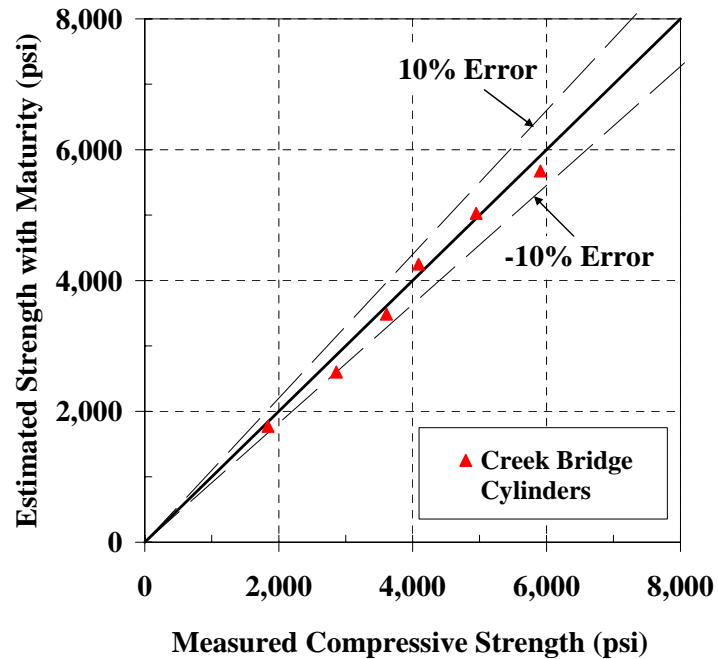

Figure 5-123: 45°-line graph for estimating the strength of the Creek A cylinders using *I-85 Bridge S-M* relationship with Arrhenius maturity function ($E = 40$ kJ/mol)

When the *I-85 bridge* S-M relationship was used to estimate strengths of the Creek A cylinders, the average absolute error ranged from 186 to 288 psi. The average absolute errors for the different datum temperatures for the Nurse-Saul maturity function ranged from 231 to 288 psi. Since the average absolute error was so close for the two datum temperatures, a conclusion could not be drawn on which datum temperature provided a more accurate estimate. The average absolute error for Arrhenius maturity function ranged from 186 to 205 psi. Since the difference between average absolute errors for both activation energies evaluated was about 20 psi, neither one of the activation energies can be determined more accurate than the other. All of the average absolute errors were fairly similar to one another; therefore, no definite conclusion can be made whether one function was better than the others. Therefore, the percent errors were evaluated to draw a better conclusion on the accuracy of the different maturity functions.

By evaluating the 45°-line graphs and the percent errors in Table 5-53, it can be determined that the Arrhenius maturity function was slightly more accurate at estimating the concrete strength than the Nurse-Saul maturity function. The activation energy of 40 kJ/mol had the lowest percent errors of all the maturity functions. The Nurse-Saul maturity function with $T_0 = -10\text{ }^{\circ}\text{C}$ underestimated the first two testing ages for the Creek A cylinders by more than -15%. This coupled with the fact that the 1-day I-85 D strength was overestimated by more than 10% indicates that Nurse-Saul maturity function with $T_0 = -10\text{ }^{\circ}\text{C}$ does not estimate the strength of the concrete accurately. For the Nurse-Saul maturity function with $T_0 = 0\text{ }^{\circ}\text{C}$, all of the percent errors were equal to or less than the 10% limit. The datum temperature of $0\text{ }^{\circ}\text{C}$ did underestimate the first two testing ages for the Creek Bridge cylinder by more than -10%, but since the underestimation the

remainder of the testing ages was within 5% error, the Nurse-Saul maturity function with $T_o = 0\text{ }^{\circ}\text{C}$ was considered acceptable for estimating the strength of the concrete.

Since the *I-85 Bridge* S-M relationship estimated the strength of the Creek Bridge cylinder accurately, the *I-85 Bridge* S-M relationship were used to evaluate the verification test strength results, which is discussed next. It was decided that the datum temperature of $-10\text{ }^{\circ}\text{C}$ was not accurate at estimating the strength of the concrete, and was not strongly considered when evaluating the verification test results.

5.8.2.2 Assessing the Verification Test Results

To evaluate the verification test results, the percent errors were calculated as explained in Section 5.5.3 and these are presented in Table 5-54. The percent errors were calculated using the *I-85 Bridge* S-M relationships. The estimated strengths from the *I-85 Bridge* S-M relationship for the I-85 A, I-85 B, I-85 C, Creek B, and Creek C cylinders are presented in Appendix C. The estimated strength from the *I-85 Bridge* S-M relationship and the corresponding measured strengths for all sets of verification cylinders and both placements are presented in Figures 5-124 and 5-125 for the Nurse-Saul maturity function with $T_o = 0\text{ }^{\circ}\text{C}$ and Arrhenius maturity function with $E = 33.5\text{ kJ/mol}$. The figures that correspond to the Nurse-Saul maturity function with $T_o = -10\text{ }^{\circ}\text{C}$ and Arrhenius maturity functions $E = 40\text{ kJ/mol}$ are presented in Appendix C.

Table 5-54: Percent errors for verification testing using *I-85 Bridge* S-M relationships

Cylinders Sets	Testing Target	Percent Error (%)			
		Nurse-Saul Function		Arrhenius Function	
		$T_o = -10\text{ }^\circ\text{C}$	$T_o = 0\text{ }^\circ\text{C}$	$E = 33.5\text{ kJ/mol}$	$E = 40\text{ kJ/mol}$
I-85 A	2,400 psi	-1%	5%	5%	9%
	7 Day	15%	15%	14%	16%
I-85 B	2,400 psi	11%	17%	17%	21%
	7 Day	16%	16%	16%	16%
I-85 C	2,400 psi	7%	11%	11%	14%
	7 Day	18%	18%	18%	18%
Creek B	2,400 psi	-17%	-14%	-14%	-12%
	7 Day	-4%	-4%	-4%	-3%
Creek C	2,400 psi	-3%	1%	1%	3%
	7 Day	12%	13%	12%	14%

- Negative percent error reflects an underestimation of the measured strength
 + Positive percent error reflects an overestimation of the measured strength

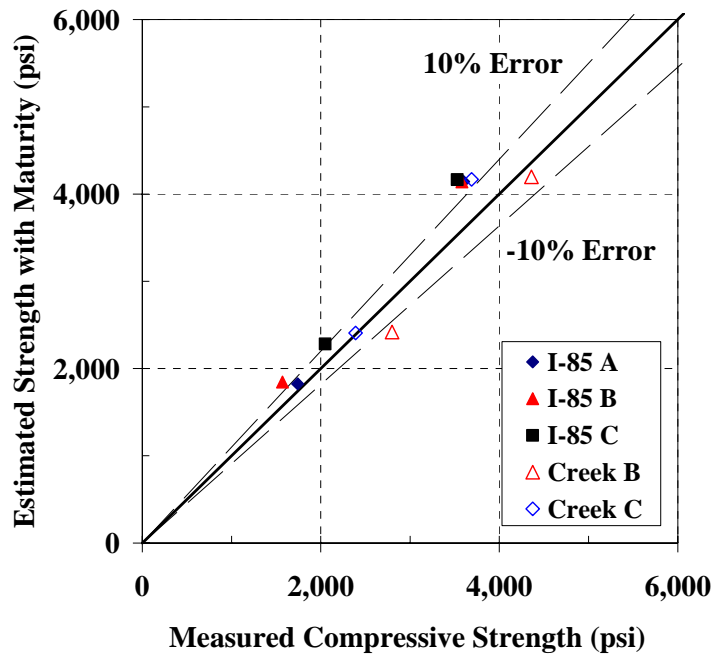

Figure 5-124: 45°-line graph for estimating the strength of the verification cylinders using *I-85 Bridge* S-M relationship with Nurse-Saul maturity function ($T_o = 0\text{ }^\circ\text{C}$)

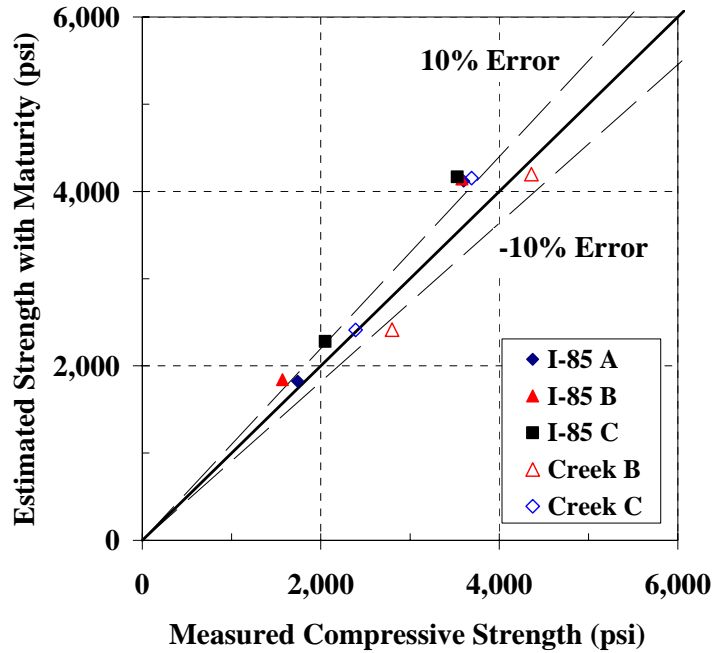

Figure 5-125: 45°-line graph for estimating the strength of the verification cylinders using *I-85 Bridge* S-M relationship with Arrhenius maturity function ($E = 33.5$ kJ/mol)

By evaluating the 45°-line graphs and the percent errors in Table 5-53, some of the verification test results were estimated satisfactorily while others were inaccurately overestimated. The 2,400-psi verification tests for the I-85 A and I-85 B cylinders were not conducted at the exact time when the concrete was supposed to reach 2,400-psi. This happened because the verification tests for I-85 bridge cylinders were conducted using a S-M relationship that was thought to be representative of the concrete placed in the bridge deck. Since the concrete properties were changed, this S-M relationship was incorrect so the verification tests were conducted at the wrong maturity. However, the accuracy of the maturity method can still be assessed by evaluating the measured strength and corresponding estimated strength at the maturity at the time of testing. For the

verification test I-85 C, the S-M relationship was being developed at the same time and therefore the maturity index that corresponded to the 2,400-psi tests was not known. The 2,400-psi test for the I-85 C verification test was conducted at approximately the required maturity index but not exactly. Therefore, the measured strength was compared to the estimated strength to assess the accuracy of the maturity method. On the other hand, since the *I-85 Bridge* S-M relationship existed for the Creek Bridge verification test, the 2,400-psi test was conducted at the correct maturity that corresponds to the 2,400-psi strength. To illustrate the percent error for the 2,400-psi verification test, Figure 5-126 shows the percent errors for all of the maturity methods. Figure 5-127 shows the percent errors for the 7-day verification tests.

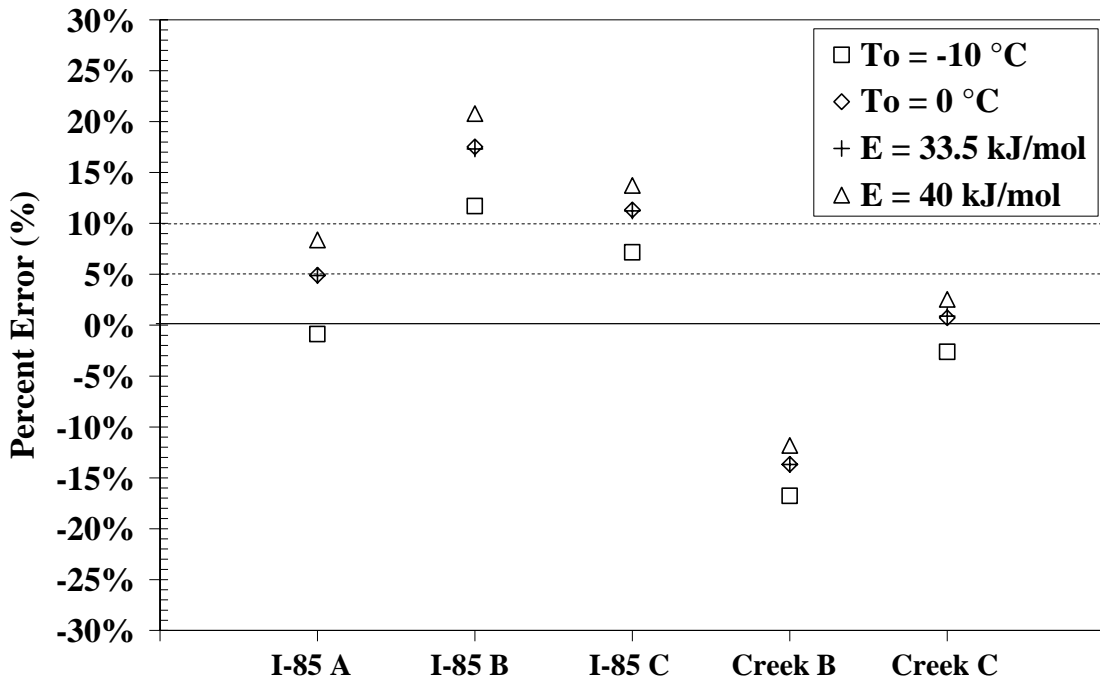

Figure 5-126: 2,400-psi verification test percent errors for best-fit *I-85 Bridge* S-M relationship

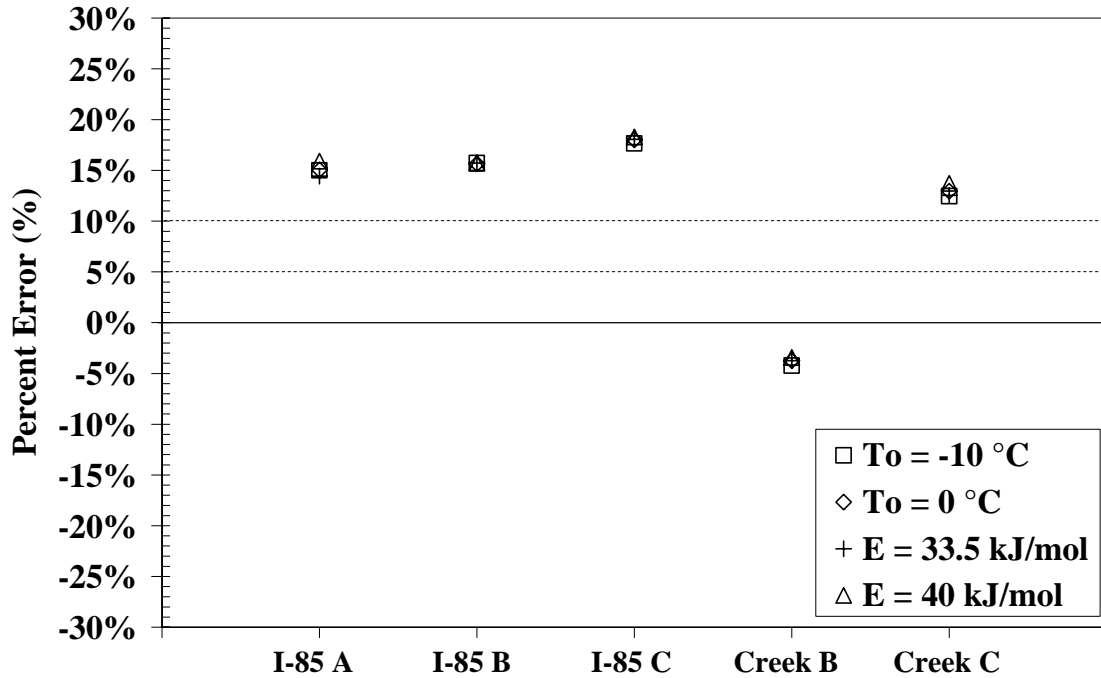

Figure 5-127: 7-day verification test percent errors for the best-fit *I-85 Bridge* S-M relationship

Some of the verification tests were within the 10% limit while others overestimated the strength by more than 10%. For the 2,400-psi verification test, sample I-85 B was overestimated by all maturity functions. The activation energy of 40 kJ/mol tended to have higher percent errors than the other maturity functions. For the 7-day verification test, all of the strengths were overestimated with the exception of the Creek B sample set. The percent errors ranged from 12% to 18% for verification tests that were overestimated. All of the maturity functions estimated the 7-day strength about the same; therefore, all the maturity functions had the same accuracy.

Four of the entire verification test results were within the acceptable criteria while six of them exceeded the 10% limit. Since some of the verification tests were estimated

correctly and other verification tests were inaccurately estimated, this indicates that a confidence level coupled with an acceptance criteria should be developed so that the verification test can be evaluated and used properly. This will be discussed in the assessment of the confidence level in Section 5.8.5.

5.8.3 EVALUATION OF THE TESTING SCHEDULE

When developing the S-M relationship's testing schedule for the molded cylinders for the bridge deck project, the recommended ASTM C 1074 testing schedule was used. Since it was determined that the water-tank-cured cylinders estimated the in-place strength most accurately, the testing schedule for the water-tank-cured cylinder was evaluated. Ideally, the number of testing ages should be the minimum number that accurately defines the strength development of the concrete.

As explained in Section 4.5.4, to capture the strength development of the concrete, a minimum of two testing ages should be on the initial slope of the strength development. At least one of the testing ages should be in the area of the curve where the strength development starts to transition from the high rate of strength development to the slower rate. Since the maturity method is usually only used for early-age strength estimating, the last testing ages to create the S-M relationship should be around 7 days. Finally, a 28-day test should be conducted for two reasons: (1) to help obtain an estimate of the ultimate strength for the exponential strength-maturity relationship, and (2) to ensure the concrete produced for the S-M relationship meets the 28-day strength requirements of the concrete for bridge deck operations.

The testing schedule that was conducted for the bridge deck project was 1, 2, 3, 7, 14, and 28 days. The strength development and testing schedule for the water-tank-cured cylinders of the mock bridge deck can be seen in Figures 5-128 and 5-129, for the cold- and warm-weather placement conditions, respectively. The ambient temperature at placement was 65 °F and 90 °F, for the cold- and warm-weather placements, respectively.

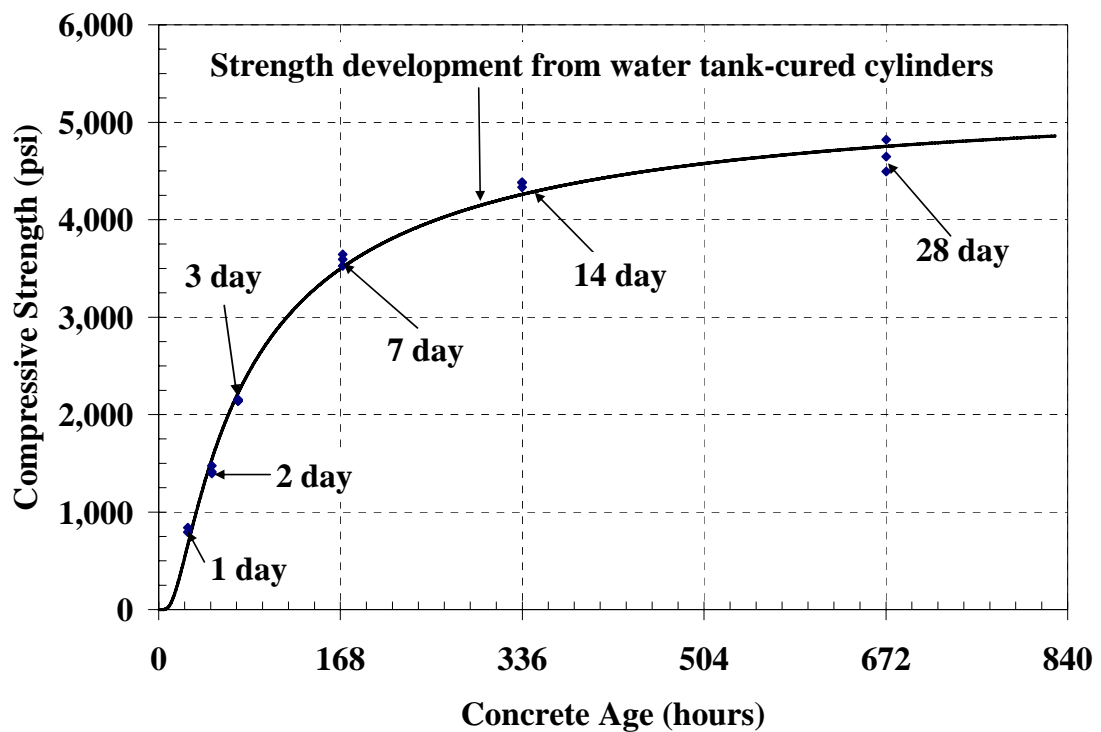

Figure 5-128: Evaluation of the testing ages for the cold-weather placement of the bridge deck field project

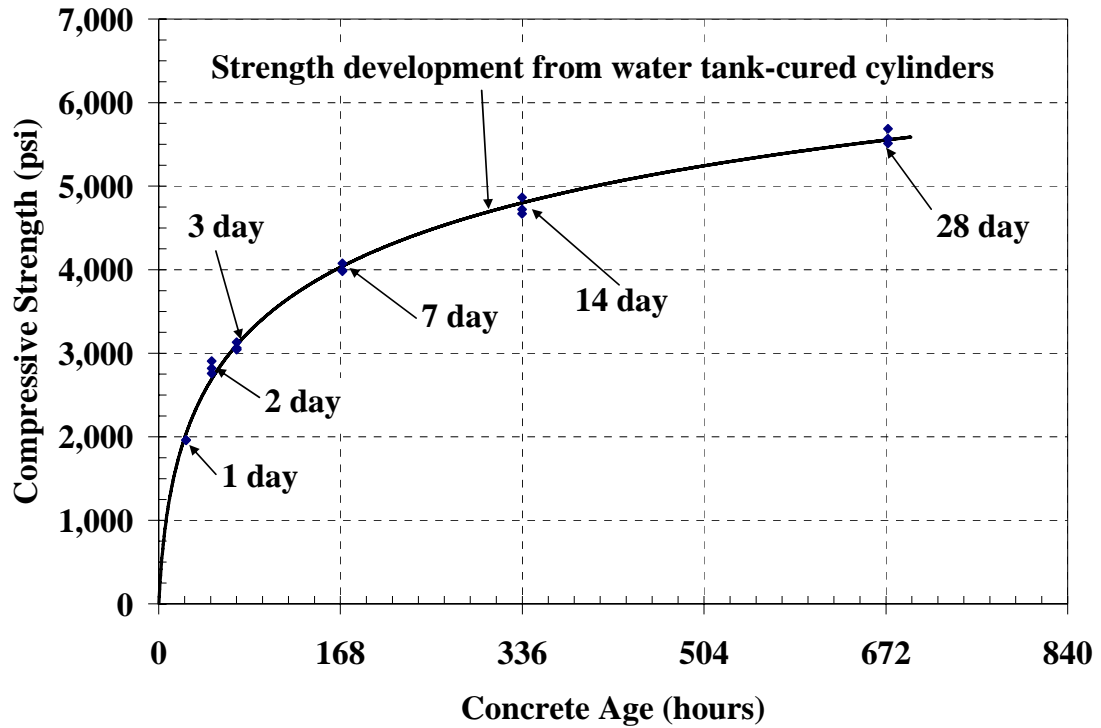

Figure 5-129: Evaluation of the testing ages for the warm-weather placement of the bridge deck field project

The cold-weather placement testing schedule adequately captured the strength development of the concrete. It is recommended to move the 3-day test age to 4 days, and the 14-day test age could be removed since the maturity method is primarily used for early-age strength estimations. For the warm-weather placement, the first couple of test ages could have been earlier to more accurately capture the initial strength development. A testing schedule should be developed to account for the ambient temperature when the concrete is placed. When the initial temperature is between 60 °F and 80 °F at time of placement, the testing schedule of 1, 2, 4, 7, and 28 days, which was used for the laboratory cured cylinders of the bridge project, should be adequate to capture the

strength development of the concrete. When the initial temperature is below 60 °F and above 80 °F, the testing schedule should be changed to account for the accelerated or decelerated strength development of the concrete. For higher ambient temperatures, the testing ages should be earlier and for lower ambient temperatures, the testing ages should be later. This is discussed more in Section 6.2.3.

5.8.4 EVALUATION OF THE CONFIDENCE LEVELS

Confidence levels were added to all of the S-M relationship graphs for the cylinder, pullout test, and core strength graphs. Confidence levels only need to be considered if a critical construction process is occurring where a specific strength is required before proceeding with construction.

For a bridge deck, the construction process is usually controlled by a required strength to either remove forms or allow construction or traffic loads on the newly cast concrete. ALDOT Standard Specification (2002) requires that an average strength of two cylinders reach the specified strength. By using the best-fit S-M relationship (an average strength) it inherently applies a 50% confidence level with a 50% defective level, and therefore half of the test results are expected to be below the average strength. Adding the confidence levels with a 10% defect level helps ensure that 90% of the strength data tested are above the estimated strength. Due to the limitations of the maturity method the construction process should not continue until a physical verification test has been conducted to verify that the specified strength has been reached.

When examining the confidence level graphs, (Figures 5-84 to 5-87) the verification testing conducted on the actual bridge concrete deck were considered the

most useful for determining the effectiveness of confidence levels. The concrete used to place each mock bridge deck was from the same batch, and therefore the results from the mock bridge deck are not as helpful at evaluating the confidence levels. On the other hand, each verification test was sampled from a different batch, and the batch-to-batch variability is higher than the variability of one batch. This can be seen in Figures 5-84 to 5-87.

For discussion purposes, the S-M relationships that are developed from the desired confidence levels using a 10% defect level will be referred to as “S-M relationship with a 10% defect level.” Using the *I-85 Bridge* S-M relationship a confidence level of 50% results in a couple of verification test results to be above the S-M relationship using 10% defect level when originally they were below the best-fit S-M relationship. The confidence level of 75% was also more effective to allow a higher number of the verification tests to be above the S-M relationship with a 10% defect level. By using a higher confidence level, it is inherently requiring the contractor to wait longer before testing the verification specimens; therefore, the confidence level should not be so high as to require the contractor to wait an excessive amount of time before proceeding.

To illustrate how the use of confidence level with a 10% defect level will help provide a more accurate estimated strength, the Figures 5-126 and 5-127 were recreated with the estimated strength from the S-M relationship with a confidence level of 50% and a defect level of 10%. The percent errors were calculated for the measured strengths from the verification tests that were conducted on the actual bridge decks to the estimated strength from the S-M relationship with a 50% confidence level and 10% defect level and are presented in Figures 5-130 and 5-131.

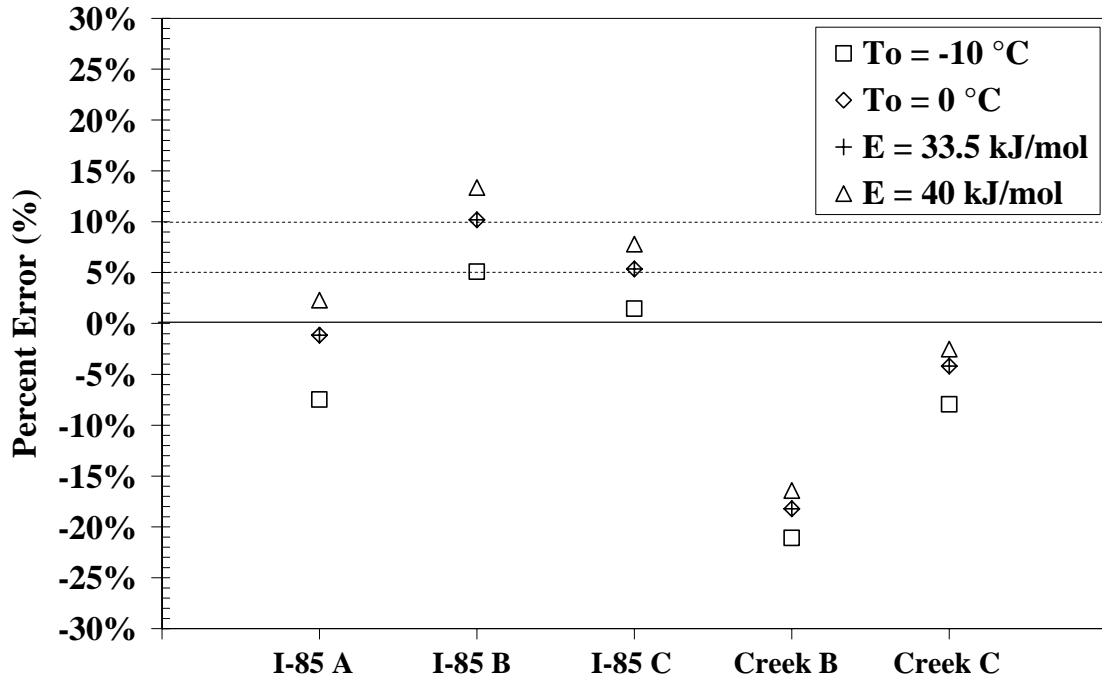

Figure 5-130: 2,400-psi verification test percent errors for *I-85 Bridge* S-M relationship using a 50% confidence level at 10% defect level

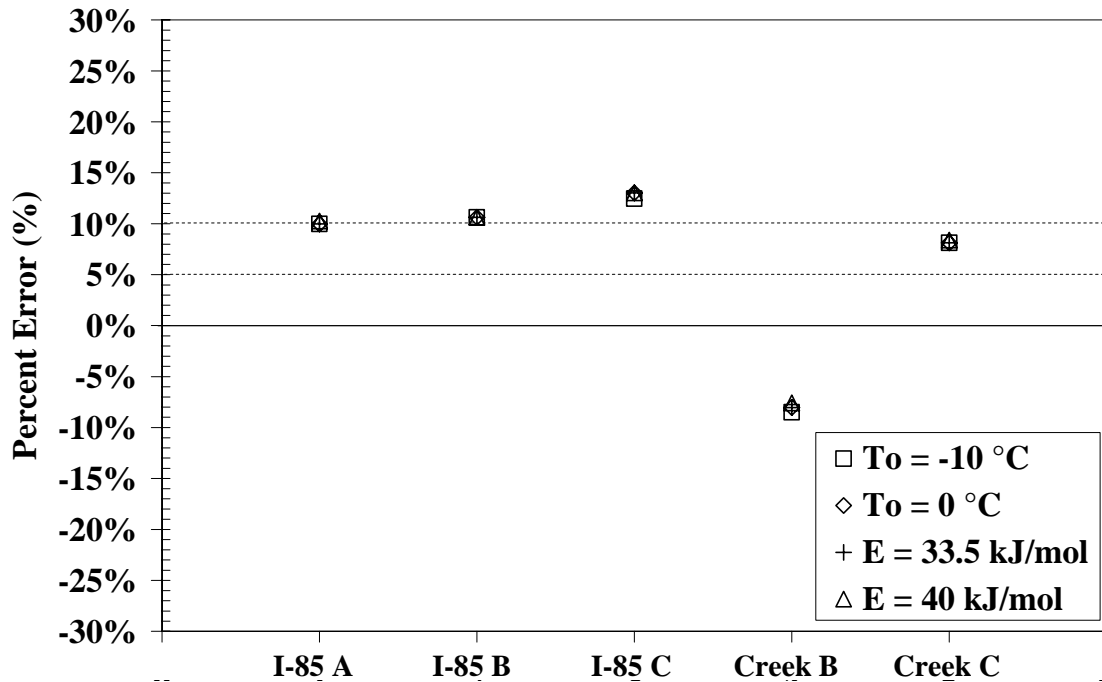

Figure 5-131: 7-day verification test percent errors for the *I-85 Bridge* S-M relationship using a 50% confidence level at 10% defect level

As shown in Figures 5-130 and 5-131, all of the percent errors were smaller than then original percent errors in Figures 5-126 and 5-127. When the best-fit S-M relationship was used to estimate the strength, the entire I-85 B cylinders were greater than the 10% error, and now with using the S-M relationship with 50% confidence level and a 10% defect level the estimated strengths from three of the maturity functions were below the 10% error line. For the 7-day verification tests, the I-85 C cylinders were greater than 10%, but the rest of the verification cylinders were at the 10% error line or less. Figure 5-127 shows that only the Creek B cylinders strengths had a percent error less than 10% when using the best-fit S-M relationship.

Not all the strength test results were above the S-M relationship with a confidence level of 50% or 75%, because statistically when using a 10% defective level, one out of every ten test results should be below the S-M relationship developed at a 10% defect level. When one of ten results are less than the estimated strength, it does not mean that the S-M relationship is inaccurate. This does require that some acceptance criteria should be developed for strengths that are still below the confidence levels, however.

If a verification strength result falls below the S-M relationship with a 10% defect level, an evaluation must be conducted to determine if the concrete in the structure is still represented by the S-M relationship. To help illustrate the issue at hand, Figure 5-132 was created using the I-85 Bridge S-M relationship using a 50% confidence level. Also added to the figure are two lines that indicate 5% and 10% strength below the estimated strength from the S-M relationship developed using a 50% confidence level and 10% defect level. The Nurse-Saul maturity function was used with a $T_o = 0$ °C.

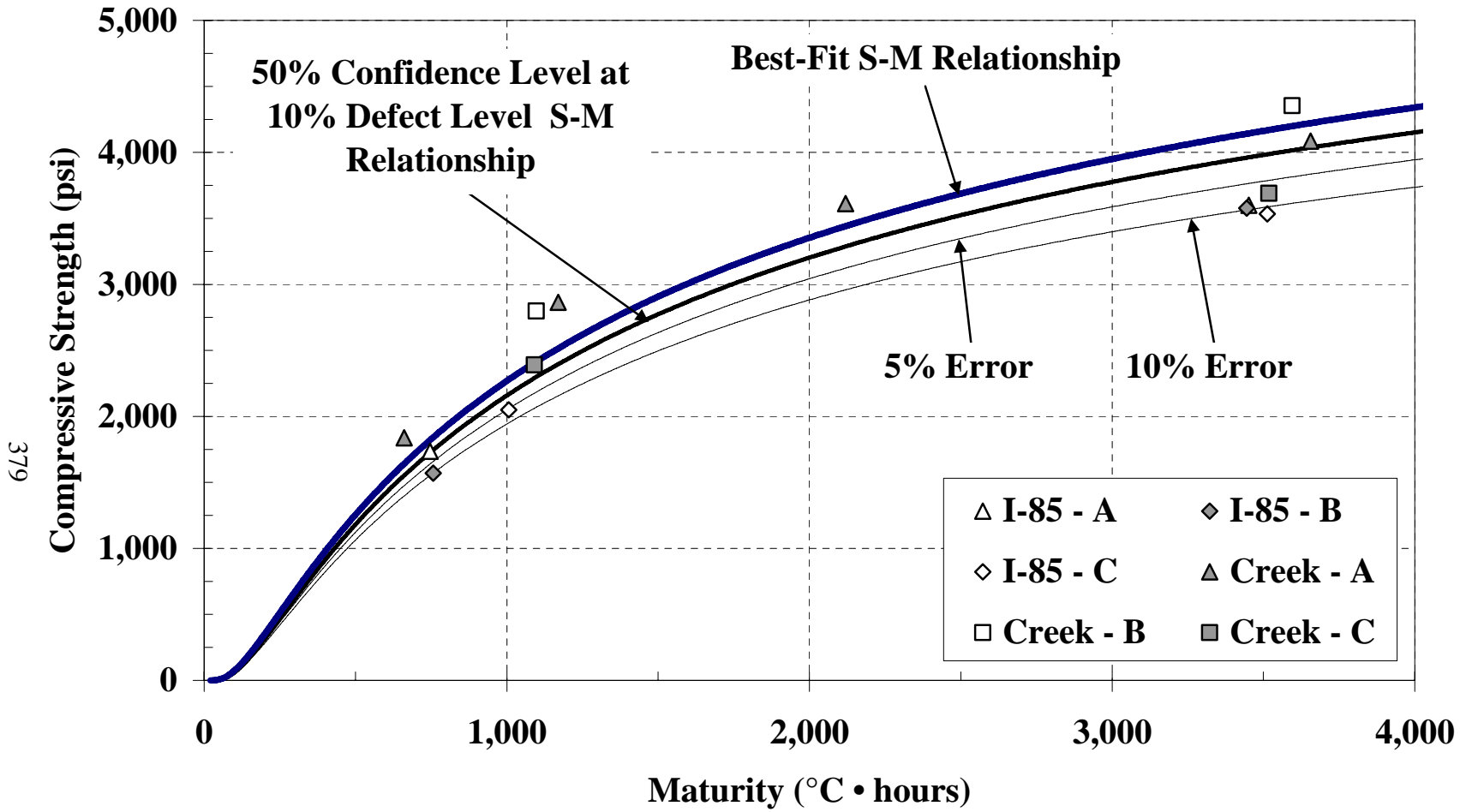

Figure 5-132: Applying a confidence level and acceptance criteria to the verification test results

As shown in Figure 5-132, many of the cylinders strengths are above the S-M relationship with a 10% defect level. However, some of the verification tests are below the S-M relationship with a 10% defect level. The 5% and 10% error lines were calculated using Equation 5-1.

$$S_{\%Error} = S_{Best-fit} \times (1 - \%Error) \quad \text{Equation 5-1}$$

Where, $S_{\%Error}$ = strength at desired % error (psi),
 $S_{best-fit}$ = strength from the best-fit S-M relationship (psi), and
 $\%Error$ = desired percent error (decimal form).

Of all of the verification tests that were below the 50% confidence level S-M relationship, only one was below the 10% error line, which is a cause for concern. Statistically it is highly unlikely for a verification test to be 10% below the S-M relationship adjusted with confidence level at a 10% defect level; therefore, the concrete that is being placed in the structure may not be the same as the concrete used to develop the S-M relationship. Alternatively, poor testing practices could have caused this defective result. In addition, a couple of the 7-day verification tests were between the 5% and 10% error lines and this is also a cause for concern because statistically as required in ACI 318 (2005), three consecutive verification tests should not be below the specified strength.

Therefore, it is recommended that if a verification test falls below 10% of the S-M relationship with a 10% defect level, then a new S-M relationship should be developed. In addition, if three consecutive verification tests fall between 5% and 10% below the estimated strength of the S-M relationship with 10% defect level, then a new S-M

relationship should be developed. This approach is similar to that currently used by TxDOT (Tex-426-A 2002), except that TxDOT uses the best-fit S-M relationship. These criteria are recommended because the concrete used to develop the S-M relationship may not be representative of the concrete being placed in the structure. Therefore, when this condition develops, the S-M relationship should be discarded and a new S-M relationship developed. During the period required develop a new S-M relationship, conventional strength acceptance procedures and testing should be used. It is also recommended that a 50% confidence level with 10% defect level be used for most construction applications unless a required strength is very essential; then a confidence level of 75% should be used. Confidence levels are only implemented to help ensure that the estimated strength reliably exceeds the specified strength (f'_c). No construction process should continue until a verification test has been conducted and the measured strength is above the required strength.

5.8.5 EVALUATION OF THE TEMPERATURE PROFILE OF THE BRIDGE DECKS

One of the objectives of the evaluation of the actual bridge deck construction was to assess the most appropriate locations to install temperature sensors. To determine the locations of the temperature sensors, a couple of factors were considered. If in-place testing will be performed along with the use of the maturity method, then the temperature sensors should be installed near the location where the in-place testing will be conducted. If the maturity method is going to be used with molded cylinders to verify the estimated strength, then the location of the temperature probe will be critical. A temperature sensor should be located at each location where the required strength is needed. If only a couple

of temperature sensors are going to be used for a bridge deck placement then it is recommended that one temperature sensor be placed at the beginning of the casting, and the other sensors should be installed at the end of the casting to capture the entire concrete placement strength development.

When using molded cylinders to verify the strength of the concrete, the temperature sensor should be placed in the location where the lowest temperatures are expected to capture the slowest strength development. Figure 5-133 shows the mid-depth temperature variation between the middle and the edge of the bridge deck.

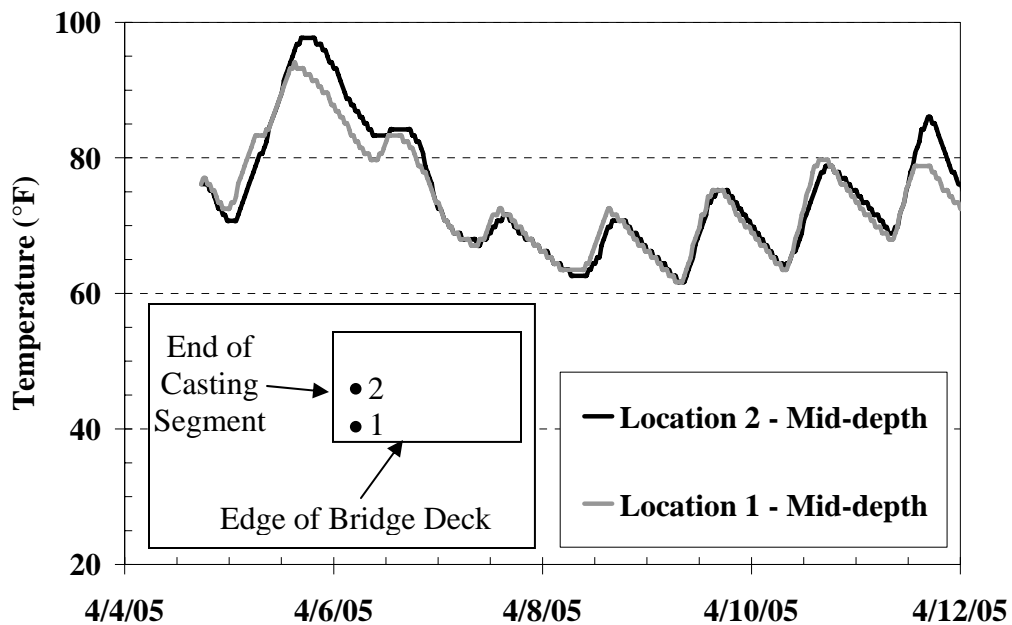

Figure 5-133: Mid-depth concrete temperature profile for middle versus edge of the Creek Bridge pour

As shown in Figure 5-133, the temperature history is different for the middle than for the edge of the bridge deck. Location 1 and 2 were covered with concrete at about the same time. Location 1 was located about two feet from the edge of the overhang of the

bridge deck, whereas Location 2 was located in the middle of the bridge deck. The temperatures at Location 1 did not reach the same temperatures that occurred at Location 2, which indicates that the rate of strength development at Location 1 was probably slower.

The other factor that should be considered is the depth at which the temperature sensors should be located. The figures that show different temperature histories for the top, mid-depth, and bottom temperature sensors are presented in Appendix C.

Temperature for location 3 of the Creek Bridge deck are shown in Figure 5-134, and only the first 3 days are shown to show the effects of cold-weather concrete placement.

Temperature for location 4 for the warm-weather placement of the mock bridge deck are presented in Figure 5-135, and only the first 5 days are shown to show the effects of warm-weather concrete placement.

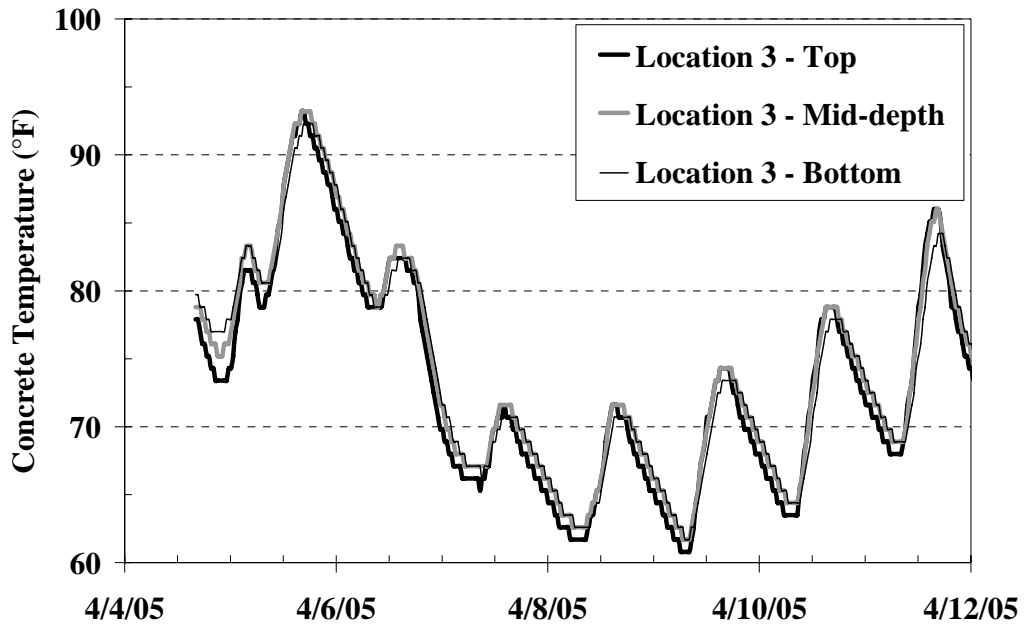

Figure 5-134: Temperature profile of Location 3 of the Creek Bridge deck

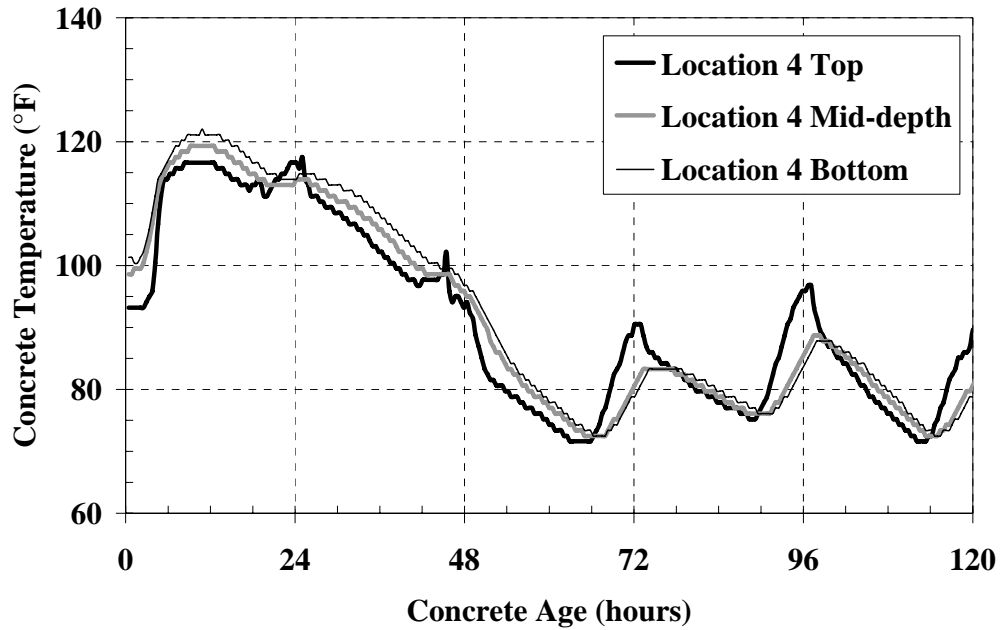

Figure 5-135: Temperature profile of Location 4 of the warm-weather placement of the mock bridge deck

The temperature profiles across the depth of the slab are similar at some times (as shown in Figure 5-134) and different at others (as shown in Figure 5-135). The top temperature sensors were located about 1½ inches from the top surface of the concrete, the mid-depth temperature sensors were about 3 inches from the top surface, and the bottom sensors were about 1½ inches from the bottom forms. As shown in Figure 5-135, the top sensors recorded most of the lowest temperatures for the first two and a half days and then recorded the highest temperatures for the next couple of day. The high degree in fluctuation of temperature recorded by the top sensors is due to the effects of the environmental conditions on the concrete. The temperatures recorded in the bottom sensors were more representative of the concrete temperatures occurring due to the hydration of the cement. During summer months, it can be expected that the top sensors

will record some of the highest temperatures. During the winter months, the top sensor will record some of the lowest temperatures. Therefore, it is recommended that the temperature sensor should be located near the bottom of the deck about 2 inches from the forms.

When placing the temperature sensor in the bridge deck, the sensor should not be in direct contact with the reinforcement. The reinforcement temperature is different from the actual concrete temperature, which was shown in Figure 5-79. A material that does not conduct heat can be used to shield the temperature sensor from the reinforcement, or the temperature sensor should be suspended away from the reinforcement.

5.9 SUMMARY AND CONCLUSIONS

Over all, the maturity method evaluated the concrete strength fairly accurately for the bridge deck project. The objectives stated in the Section 5.1 were accomplished. The S-M relationships that were developed using the cylinders curing in water-tank-cured conditions all estimated the in-place strength fairly accurately. On the other hand, the S-M maturity relationship developed from cylinders that were cured under laboratory conditions mostly did not estimate the in-place strength accurately. The *laboratory* S-M relationship was fairly inaccurate at estimating the strength of the water-tank-cured cylinders for the cold-weather placement of the mock bridge deck.

Four different maturity methods were evaluated, Nurse-Saul maturity function with $T_o = -10\text{ }^\circ\text{C}$ and $T_o = 0\text{ }^\circ\text{C}$ and Arrhenius maturity function with $E = 33.5\text{ kJ/mol}$ and $E = 40\text{ kJ/mol}$, and conclusions are as follows:

- The Nurse-Saul maturity function with $T_o = 0$ °C estimates the in-place more accurately than $T_o = -10$ °C for both the cold and warm-weather placements.
- The Arrhenius maturity function with $E = 40$ kJ/mol was more accurate for the cold-weather placement and $E = 33.5$ kJ/mol was more accurate for the warm-weather placement.
- The one maturity function that was the most accurate for estimating both the cold and warm-weather placement was the Nurse-Saul maturity function with $T_o = 0$ °C.

For the ages where the Nurse-Saul maturity function with $T_o = 0$ °C exceeded the percent error limits, the strengths were mostly underestimated, which is conservative. The testing times when the underestimation of the strength occurred was the 1-day test age for most of the in-place testing. Therefore, since the few errors that exceeded the limit were conservative, the $T_o = 0$ °C was considered accurate for assessing the in-place strength of the concrete.

The conclusions from evaluating the *water-tank* S-M relationship to estimate the strength of each in-place testing methods are as follows:

- For the pullout strength the Nurse-Saul maturity function with $T_o = 0$ °C was the most accurate when considering both the cold and warm-weather placements.
- For the CIP cylinder the Arrhenius maturity function estimated the strength more accurately than the Nurse-Saul maturity function;

however, the Nurse-Saul maturity function with $T_o = 0$ °C never overestimated the strengths.

- For estimating the strengths of the cores from the cold-weather placement, all maturity functions were accurate.
- For estimating the strengths of the cores for the warm-weather placement all maturity functions overestimated the strength by a substantial amount.

Since the pullout test and CIP cylinders strengths were estimated fairly accurately for the warm-weather placement of the mock bridge deck, the cores strengths for the warm-weather placement were not considered in the evaluation of the maturity method.

Final evaluations of the testing schedule for the water-tank-cured cylinders were conducted, and it was concluded that a testing schedule that changes with the ambient temperature when the concrete is placed should be developed. For concrete that is placed between 60 °F and 80 °F the testing schedule of 1, 2, 4, 7, and 28 days is adequate for developing a *water-tank* S-M relationship for a bridge deck. Testing schedules for concrete placed at other temperatures, are discussed in Section 6.2.3.

The evaluation of the use of molded cylinders for verification testing helped determine how the maturity method should be implemented on the construction site. The molded cylinder verification testing proposed in Section 9.5.4 of ASTM C 1074 could be a valid way of estimating strength of the concrete. To do so, confidence levels should be applied to the S-M relationship to help ensure the required strength is reached before verification testing. The confidence level of 50% with a 10% defect level seems to be adequate for developing the S-M relationship. However, some acceptance criteria should

be developed to ensure that the concrete being placed in the structure is represented by the S-M relationship with 10% defect level. The following acceptance criteria are recommended:

- If a verification test falls below 10% of the S-M relationship with 10% defect level then the S-M relationship with 10% defect level is not valid and a new S-M relationship must be developed.
- If three consecutive verification test fall between 5% and 10% below the estimated strength of the S-M relationship developed with 10% defect level then the S-M relationship is not valid and a new S-M relationship must be developed.

These criteria are designed to identify concrete that might not be the same as the concrete used to develop the S-M relationship with 10% defect level. If the verification test does not reach the required strength then the construction process shall not continue until the required strength is reached. If a new S-M relationship is to be developed then conventional testing to verify the strength of the concrete must be conducted until the new S-M relationship is developed.

Temperature sensor should be placed in the area of the bridge deck where the minimum temperature of the concrete exists. By using the minimum temperature history of the concrete, the slowest strength development of the concrete is captured. The recommended location for the temperature sensors for the bridge deck project are as follows:

- Place the sensors near the edge of the bridge deck in the overhang.
- The temperature sensors should be located at the bottom of the deck, approximately 2 inches from the forms.

In general, the maturity method estimated the concrete in-place strength for the bridge deck construction process accurately. *Water-tank* S-M relationships should be used because they were more accurate at estimating the in-place strength of the concrete than the *laboratory* S-M relationship. The maturity method process will work as long as testing is conducted and monitored properly.

CHAPTER 6

IMPLEMENTATION OF THE MATURITY METHOD

After analyzing the results of the labwork and fieldwork phases, a proposed specification was drafted from lessons learned from these phases, and from other state departments of transportation (DOTs) specifications. The objectives of this chapter are to review other state DOTs specifications for the maturity method, recommend requirements to be included in a maturity method specification, and outline a proposed ALDOT maturity method specification. A draft of a proposed ALDOT specification is located in Appendix D.

6.1 STATE DEPARTMENT OF TRANSPORTATION PRACTICES

Before a maturity method specification could be written for ALDOT, a detailed review of three other state departments of transportation specifications that have used the maturity method was conducted. Texas, Iowa, and Indiana were the three DOTs reviewed. Each of the state DOTs specifications were found on their respective websites. During the specification review process, the following four categories were identified and considered to evaluate these specifications: 1) general requirements for using the maturity method, 2) developing the strength-maturity (S-M) relationship, 3) estimating in-place strength, and 4) verifying the estimated strength from the S-M relationship.

6.1.1 TxDOT MATURITY METHOD SPECIFICATION TEX-426-A

The Texas Department of Transportation (TxDOT) specification for using the maturity method to estimate the in-place strength of freshly cast concrete is defined in Tex-426-A (2004) and it is given in Appendix E. TxDOT allows the maturity method to be used for portland cement concrete (PCC) pavements and structures. The Nurse-Saul maturity function is utilized with a datum temperature of -10°C . Tex-426-A specification outlines the use of a thermocouple wire maturity meter for recording maturities; however, it allows the use of other types of maturity recording devices. On any construction project, the same type of maturity meter must be used for all maturity method applications. All temperature recording devices must have an accuracy of $\pm 1^{\circ}\text{C}$. Throughout the entire testing process on construction projects, both molded cylinders and flexural beam specimens can be used for strength testing, but the specimen type has to stay consistent. If the placed concrete's w/c exceeds the w/c of the concrete used to develop the strength-maturity relationship by 0.05 or more, a new S-M relationship must be developed. TxDOT requires that three specimens be tested at each age to develop the S-M relationship. TxDOT further requires that the strength estimated by the maturity method be verified by testing laboratory-cured cylinders during critical construction operations.

6.1.1.1 Developing the Strength-Maturity Relationship

When developing a S-M relationship, a minimum of 20 specimens must be cast from the same concrete mixture used to construct the concrete structure or pavement. A minimum batch size of 4 yd^3 is required to develop a S-M relationship. The fresh concrete properties of the batch should be tested for quality control purposes. Upon casting the

specimens, thermocouple wires are embedded into at least two specimens, and then connected to separate maturity meters. The wire must be embedded 2 to 4 inches from the surface of the specimen. After casting all specimens, curing is conducted under standard laboratory conditions. Recommended testing ages are 1, 3, 5, 7, 14, and 28 days. At each testing age the maturity index is read from both maturity meters and then averaged. The strength for a specified testing age is determined by averaging the strength of three specimens. Requirements exist in the specification to eliminate any outlying test results. Once data collection is complete, a plot of the average strength and corresponding maturity values are developed using a Microsoft Excel® spreadsheet provided by TxDOT. The logarithmic function (as defined in Equation 2-9) is used to estimate the strength and then a best-fit curve is determined for the data set. The corresponding R^2 value for that curve cannot be less than 0.90.

6.1.1.2 Estimating the In-Place Strength

When using the maturity method to estimate the in-place strength of concrete, a TxDOT inspector should be present at the concrete batch plant to monitor batch processing. This ensures good control of the concrete batching operation. At each location within the structure where the maturity method is used, two thermocouple wires are to be installed and connected to a maturity meter. The wire shall be located 2 to 4 inches from any surface or at mid-depth for sections less than 4 inches. The wire shall not be in direct contact with any steel. Immediately after concrete placement, the maturity meter should start recording as soon as possible. Once the maturity index of the in-place concrete has reached the maturity that corresponds to the required strength as determined from the

S-M relationship, the in-place concrete strength is assumed sufficient. When required, strength verification testing shall be conducted if the maturity index is equal to or greater than the maturity index determined from the S-M relationship. Operations requiring S-M relationship verification include removal of critical formwork or falsework, stressing of steel, and/or other safety-related operations.

6.1.1.3 Verifying the Strength-Maturity Relationship

In order to verify the S-M relationship, three specimens are cast from the concrete that is used to cover the thermocouple sensors in the structure. The fresh concrete properties of the batch should be tested for quality control purposes. A thermocouple wire is embedded into two of the three specimens, placed 2 to 4 inches from any surface. Specimens are cured under laboratory conditions until the required time of testing. Strength testing is performed when the specimens achieve the maturity index corresponding to the required strength, or when the maturity index of the structure is achieved. A comparison of the average measured strength to the estimated strength from the S-M relationship is conducted to determine if the verification test falls within the allowable tolerance limits. One tolerance limit is if the verification test is within 10% of the estimated strength, the concrete is considered to have reached sufficient strength and construction operation can continue. The second limit is if three consecutive verification test results fall between 5% and 10% above or below the S-M relationship, the S-M relationship must be adjusted to fit the new set of data. The adjustments are made using a feature that is built into the spreadsheet provided by TxDOT for using the maturity method. If one verification test

varies by more than $\pm 10\%$ of the estimated strength from the S-M relationship, a new S-M relationship must be developed.

6.1.2 IOWA MATURITY METHOD SPECIFICATION IM 383

The Iowa DOT provides a specification (IM 383 2004) for using the maturity method to evaluate the strength of freshly cast concrete, and it is presented in Appendix F. The Iowa DOT maturity method specification is allowed to be used for concrete pavements and structures. The Nurse-Saul maturity function is used with a datum temperature of $-10\text{ }^{\circ}\text{C}$. The contractor is responsible for developing the S-M relationship and performing temperature monitoring. Both molded cylinders and flexural beam specimens can be used as long as same specimen type is used for the entire project. If the w/c of the placed concrete exceeds the w/c of the concrete used to develop the S-M relationship by 0.02, a new S-M relationship must be developed. Three specimens are tested at each designated maturity index for S-M relationship development and verification testing. A maturity meter or temperature sensor is used to monitor the temperature history of the concrete.

6.1.2.1 Developing the Strength-Maturity Relationship

When developing the S-M relationship, the ambient temperature must be above 50°F . A minimum of 12 specimens must be cast from a 3-yd^3 minimum batch size of the concrete mixture that is used for the construction effort. The fresh concrete properties of the batch should be tested for quality control purposes. Two thermocouple wires are embedded into one specimen at mid-depth and 3 inches from any surface. Casting, curing, and testing of specimens are to be conducted at the concrete plant. Curing of the specimens is

performed in a wet sand-pit after removal from the molds. The testing ages are based on the maturity of the concrete. All tests are performed at somewhat consistently spaced intervals of time that include required strengths. Suggested maturity values for standard concrete mixtures are shown in Table 6-1.

Table 6-1: Approximate maturity values for testing (IM 383 2004)

Mixture Type	<i>Nurse-Saul Maturity (°C • hr)</i>			
	Test 1	Test 2	Test 2	Test 4
A Mix	750	1,500	2,500	3,500
B Mix	1,500	3,500	5,500	7,500
C Mix	750	1,500	2,500	3,500
M Mix	600	1,200	2,000	3,000

A Mix is a concrete mixture for PCC pavements that acquires a flexural strength of 500 psi in approximately 14 calendar days. B Mix is also a PCC pavement mixture that acquires a flexural strength of 400 psi in approximately 14 days. C Mix is a fast-setting mixture acquiring a flexural strength of 500 psi in approximately 7 days. D Mix is a rapid-setting concrete mixture acquiring a flexural strength of 500 psi in approximately 48 hours (Iowa DOT Standard Specification 2005).

Upon completion of all strength tests, the average maturity index and average strength are recorded. The logarithmic function (as defined in Equation 2-9) is used to estimate the strength, and the best-fit S-M relationship is obtained for the data using a spreadsheet program.

6.1.2.2 Estimating the In-Place Strength

To estimate the in-place strength, a thermocouple wire is placed at the pavement mid-depth and 1.6 feet from the longitudinal pavement edge. A minimum of two sensors shall be placed each day during concrete placement. For concrete structures, a minimum of two sensors shall be installed in the upper corner of the exposed surface. Attaching the wire to the reinforcing steel is permitted, as long as the end of the wire is not in direct contact with the steel. After wire placement, the maturity meter is connected and recording started immediately after concrete placement. When the placed concrete's maturity index equals or exceeds the maturity index of the required strength, the concrete structure or PCC pavement is considered to have achieved the specified strength. Verification testing, to ensure that the specified strength has been achieved, is *not* required to verify the in-place concrete strength.

6.1.2.3 Verifying the Strength-Maturity Relationship

Instead of conducting verification tests like those done by TxDOT which are used at critical locations, a verification test is conducted once a month to determine if the concrete being produced is representative of the current S-M relationship. The same casting procedures used to develop the S-M relationship are used to cast three specimens from the concrete mixture used at the construction site. The specimens are strength tested at the maturity that corresponds to the required strength. If the difference between the flexural strength and the estimated flexural strength of the S-M relationship at the same maturity index is less than 50 psi, the pavement is considered to have sufficient strength. A new S-M relationship must be created if the difference is more than 50 psi. On average

for most of Iowa's PCC mixtures, this difference is about 10% of the required strength. For concrete structures, if the average strength from the verification test is less than the estimated strength from the S-M relationship, at the same maturity index, a new relationship must be developed.

6.1.3 INDIANA MATURITY METHOD SPECIFICATION ITM 402-04T

The Indiana DOT has developed specification ITM 402-04 T (2004) that governs the use of the maturity method for estimating concrete strength, and it is presented in Appendix G. Indiana only allows the maturity method to be used for PCC pavements; therefore, only flexural beams are used in the Indiana DOT testing procedures. The Nurse-Saul maturity function is used with a datum temperature of -10° C. Three specimens are tested at the designated ages for developing the S-M relationship and for verification testing. A maturity meter or temperature sensor is allowed for recording the temperature of the concrete.

6.1.3.1 Developing the Strength-Maturity Relationship

The S-M relationship is developed from a minimum of 12 specimens cast from the same concrete mixture used at the construction site. Fresh concrete testing is conducted and no requirement exists for batch size when developing the S-M relationship. One thermocouple wire is embedded in a specimen 3 inches from the end of a beam at mid-depth. All specimens are cured under laboratory conditions, and after 24 hours the forms are removed. Strength testing begins at a concrete age of 24 hours and continues every 12 hours until the required strength is exceeded by test data. The maturity index and average

strength is recorded at each test age. Alternate testing schedules may be used upon Engineer approval. Once all strength data and maturity values have been obtained, a best-fit S-M relationship from the average flexural strengths is formulated for the data using regression analysis and the R^2 value shall not be less than 0.95.

6.1.3.2 Estimating the In-Place Strength

To estimate the strength of PCC pavements, a minimum of two thermocouple probes are placed 100 feet from the end of the day's production, or the last patch of the day. Each wire is embedded at mid-depth of the pavement section and must be embedded 1.6 feet from the edge of the pavement. If a maturity meter is used, the meter is connected immediately after concrete placement and recording is started. The PCC pavement is considered to have sufficient strength and can be opened to traffic when the maturity of the placed concrete reaches the specified maturity index for the required strength established by the S-M relationship. No verification testing is required to verify the strength of the pavement.

6.1.3.3 Verifying the Strength-Maturity Relationship

Instead of verification testing at sensor locations, a verification test is required to determine if the concrete placed is the same as the concrete used to create the S-M relationship. Verification testing requires three specimens be cast the same way as the specimens that were cast to develop the S-M relationship. For PCC pavements, verification tests are conducted on the third subplot of every fourth lot, and for PCC pavement patching, tests are conducted on the first day of production and once every

600 yd³. Lots are equal to 7,200 yd², and sublots are equal to 2,400 yd² (INDOT Standard Specification Book 2006). Tests are conducted at the desired maturity values for opening the pavement to traffic. If the verification test is within ± 50 psi of the estimated strength from the original S-M relationship, the relationship is deemed valid. For PCC pavements in Indiana, the average flexural strength required for opening the pavement to traffic is 570 psi (INDOT Standard Specification Book 2006). If the verification test differs by more than ± 50 psi of the original S-M relationship, a new S-M relationship must be developed.

6.2 NECESSARY REQUIREMENTS FOR IMPLEMENTATION

An acceptable maturity method specification should contain clear instructions on how to implement the maturity method. The specification should define what maturity functions should be used along with the appropriate temperature sensitivity values. Several important steps requiring detailed descriptions include: 1) how to develop the S-M relationship, 2) how to estimate the in-place strength, and 3) how to verify the in-place strength of the concrete used in the concrete structure or PCC pavement. An example to assist ALDOT and contractor personnel, including all applicable spreadsheets, detailing proper procedures on the use of the maturity method should be included with the specification.

6.2.1 MATURITY FUNCTION AND CORRESPONDING VALUES

After extensive evaluation of the laboratory experiment results, the two field project results, ASTM C 1074 (2004), and other DOT specifications, it is recommended to use

the Nurse-Saul maturity to calculate the maturity index. Two immediate advantages for using the Nurse-Saul maturity function is that it is simple to understand and easily employable. The recommended datum temperature is 0 °C. A datum temperature of 0° C can be used for all temperature ranges and all normal concrete mixtures specified by ALDOT. If other special concrete mixtures are specified, then an evaluation of the datum temperature 0° C should be performed to verify that it will provide acceptable results for that particular concrete mixture.

6.2.2 TEMPERATURE RECORDING OR MATURITY RECORDING DEVICES

The specification should not be written requiring the use of only one type of temperature or maturity recording device. Currently many different acceptable devices are commercially available that can be used to record the temperature or maturity history of the concrete. The temperature sensitivity of the instrument should be $\pm 1^\circ \text{C}$, as recommended by ASTM C 1074 (2004).

In addition, the temperature or maturity recording device should record temperatures in intervals as specified by the ASTM C 1074 (2004). ASTM C 1074 requires that concrete temperatures be recorded every $\frac{1}{2}$ hour for the first 48 hours and then every hour thereafter. If the temperature or maturity device has the capability of recording temperatures at smaller time intervals, a sampling interval of 15 minute will yield sufficiently accurate results. In addition, the same temperature or maturity recording device should be used to develop the S-M relationship, to estimate the in-place strength, and for verification testing.

During the selection of the maturity recording equipment, a couple of issues should be considered. First, it is recommended that the maturity recording device be capable of recording and storing the temperature history of the concrete as well as calculating the maturity within the device. This it will minimize any human errors that can occur with the calculations as well as reduce the man-hours required to use the maturity method. With this in mind, the maturity recording device should have programming capability to set the required temperature sensitivity values (datum temperature). In addition, having the ability to include a job site ID number and description would be advantageous if numerous maturity sensors are to be used on a job site.

It is also recommended that the selected maturity device be self-sufficient in terms of recording, and not require any auxiliary measuring equipment be attached and remain outside of the concrete throughout the testing duration. Unfortunately, auxiliary measuring equipment exposed outside the concrete structure is inherently vulnerable to theft and can be destroyed or broken by environmental conditions or construction equipment. Finally, if sensors are being embedded in a critical concrete section, the sensors should be as small as possible to eliminate any interference they might have on the physical properties of the concrete. For example, in a prestressed concrete operation where a considerable amount of steel is present in a small volume of concrete, the maturity sensor needs to be very small and not positioned at any critical location within the girder.

6.2.3 DEVELOPING THE STRENGTH-MATURITY RELATIONSHIP

The S-M relationship must be developed with a high degree of confidence for it to be useful. Several steps must be taken to develop an accurate S-M relationship. The steps include:

- 1) Cure the specimens to best reflect the temperature history of the concrete in the structure,
- 2) Use testing a schedule that will accurately characterize the strength development of the concrete,
- 3) Test an adequate number of specimens,
- 4) Record the concrete temperature history, and
- 5) Determine the correct mathematical function to model the strength development of the concrete.

First, the specimen curing conditions must be selected to developed the S-M relationship. ASTM C 1074 (2004) requires that the specimens be cured under laboratory conditions, but it is evident from the results obtained from the field-testing phase that laboratory conditions do not always produce the most accurate S-M relationship to estimate the in-place strength. As discussed in Section 2.5.1 and supported by results of the laboratory study in Section 3.3, the initial curing temperature can influence the long-term strength of the concrete. If the initial curing temperatures are high, the long-term strength will decrease (due to the cross-over effect). This deficiency of the maturity method can be problematic during summer construction efforts. If the S-M relationship is developed under laboratory conditions, concrete placed on a construction site during the

summer months could have significantly higher initial curing temperatures causing the ultimate strength of the concrete to be lower. Therefore, the laboratory S-M relationship for some mixtures may be unconservative for concrete placed in elevated ambient temperature environments.

From the two field studies, it was determined that the field-cured specimens reflected the in-place strength more accurately than the laboratory specimens did. Two field curing methods were conducted: 1) lime-saturated water-tank, and 2) damp-sand-pit. Iowa IM 383 (2004) specification requires that the field specimens be cured in a wet sand-pit. From the prestressed girder plant field study, no major difference was found between the temperature histories of the lime-saturated water-tank and damp-sand-pit cured cylinders. The lime-saturated water-tank was easier to use and maintain in comparison with the damp-sand-pit. Therefore, it is recommended that the specimens used to develop the S-M relationship be cured in a lime-saturated water-tank in the field. If the maturity method is used on the project that is constructed over multiple seasons, a seasonal S-M relationship should be created in order to capture the different effects of each season. At a minimum, two unique seasonal S-M relationships should be created for the summer and winter months. This will ensure that the S-M relationship is accurate for all seasons.

ASTM C 1074 (2004) recommends that five testing ages be conducted for laboratory cured specimens at ages of 1, 3, 7, 14, and 28 days. If a high-early strength concrete is used, ASTM C 1074 recommends that an earlier testing age be conducted but that a minimum of five testing ages be conducted nonetheless. From the laboratory study, it was determined that earlier age testing would capture the initial strength development

of normal concrete and this procedure would develop a more accurate S-M relationship. Figure 6-1 is a comparison of the compressive strength versus concrete age of a Type I + 30% Type C fly ash concrete mixture tested under laboratory conditions (Wade 2005). The testing ages were 15 hours, 1, 2, 7, 14, and 28 days.

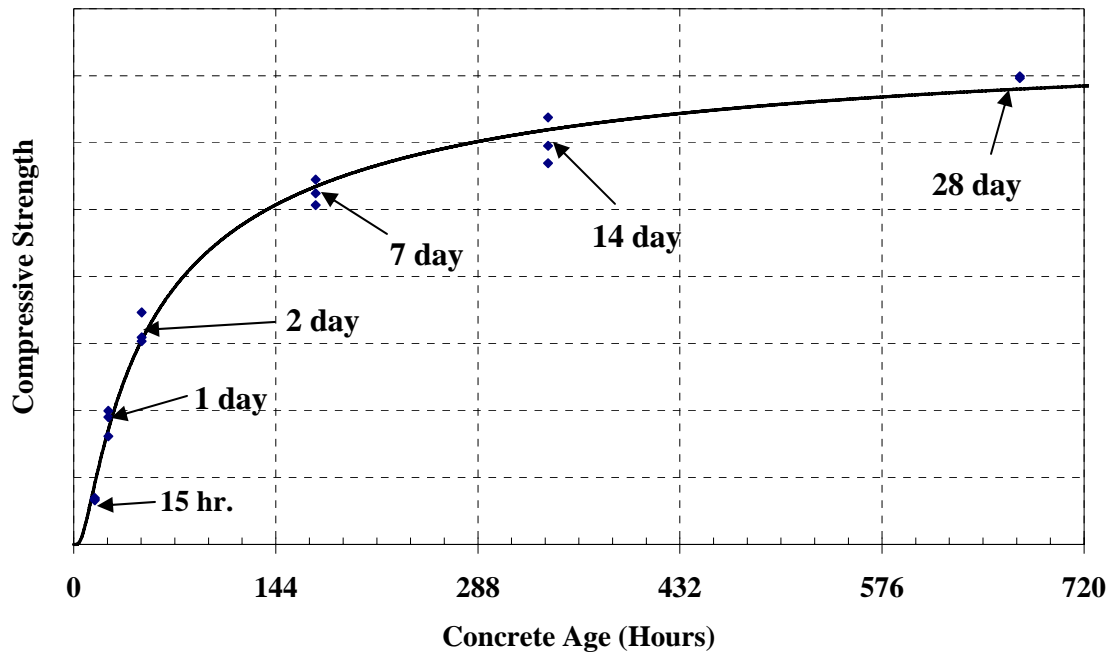

Figure 6-1: Testing ages to accurately model the strength development of concrete (Type I + 30% Class C Fly Ash)

To accurately define the strength development relationship, it is necessary to have at least two test results on the initial slope of the strength development to ensure that the rate of concrete strength development is correctly modeled. If the ASTM C 1074 recommendation of 1- and 3- day testing ages were followed, the initial slope would not have been captured. In addition, at least one test result should be conducted near the transition area where the high initial strength development rate begins to decrease and the strength development curve begins to turn towards its ultimate plateau. Finally, two test

results should be tested in the latter part of the strength development curve to capture the slower rate of strength development.

The maturity method should only be used to estimate early-age strengths, and the traditional 28-day test result is not required to develop a S-M relationship. The collection of test results until an equivalent age of 7 days will be adequate for developing the S-M relationship to estimate early-age concrete strengths. The developed 7-day S-M relationship must also incorporate the specified strength level required before allowing construction or traffic loads. However, by conducting a test at 28-days, this result can be used for quality control purposes. If the concrete being produced to develop the S-M relationship does not meet the 28-day requirement for design, the concrete mixture proportions must be adjusted and a new S-M relationship must be developed. From the laboratory and field testing results, it is recommended that the testing ages of 1, 2, 4, 7, and 28 days be used for concrete with an initial temperature near the laboratory conditions (60 to 80 °F).

Under field curing conditions a constant temperature is not used to cure the S-M relationship specimens, the testing ages must vary with different curing temperatures. For concrete where the initial curing temperatures vary between 60 and 80 °F the testing ages should be 1, 2, 4, 7, and 28 days. As for other curing conditions, the equivalent ages for the testing ages should be calculated using the Nurse-Saul maturity function with a datum temperature of 0° C as discussed in Section 2.3.1. In accordance with the ALDOT Standard Specification (2002), concrete shall not be placed when the ambient temperature is below 40 °F. Therefore, two different equivalent ages were calculated for concrete temperatures between 40 to 50 °F and 50 to 60 °F. The ALDOT Standard Specification

(2002) also requires that the fresh concrete temperature under hot weather placement shall not exceed 90 °F for bridge deck of construction. With this requirement in mind, an equivalent age was calculated for ambient temperatures between 80 to 90 °F. All equivalent age calculations were performed with the average temperature of each range. An additional category was developed and equivalent ages were calculated for extreme circumstances when concrete is placed in temperatures above 90 °F. ALDOT Standard Specification (2002) allows all other concrete to be placed up to a concrete temperature of 95 °F. Concrete is not to be placed at temperatures above 95 °F unless approved by ALDOT. To calculate the equivalent age for concrete above 90 °F, an isothermal temperature of 95 °F was used. Table 6-1 outlines the recommended testing ages for normal concrete with different initial curing temperatures. Some of the ages were rounded to practical times.

Table 6-2: Testing ages for normal-strength concrete

Initial Ambient Temperatures (°F)	Set 1 (Hours)	Set 2 (Days)	Set 3 (Days)	Set 4 (Days)	Set 5 (Days)
40 -50	36	3	6	10	28
50 - 60	30	2 1/2			
60 - 80	24	2	4	7	
80 - 90	20	1 3/4	3	6	
> 90	18	1 1/2			

At each testing age, ASTM C 1074 requires that two specimens be tested to determine the average strength of the concrete. Texas, Iowa, and Indiana DOTs all require that three specimens be use to determine the average strength. This procedure

was found to be necessary as it allows identification of a potential outlier, while also obtaining a more accurate average strength. Outliers should be removed if an individual specimen has a difference greater than $\pm 10\%$ from the average of the other two specimens (ASTM C 1074 2004). The final recommendation is that at each testing age, three specimens be tested and after any outliers have been removed, the average strength of the specimens be used to develop the S-M relationship. An additional specimen should be made to allow the maturity of the concrete to be measured. Therefore, a minimum of 16 specimens are required to develop the S-M relationship for normal concrete.

For concrete used in prestressing operations, the break schedule is different from the normal concrete break schedule due to the accelerated curing conditions. During the prestressed plant project the field-cured specimens were tested at 8, 12, 18, 24, 48 hours, and at 4, 7, and 28 days. Field specimens were cured using the same curing procedures used to cure the girder for the first 18 hours. At this time, the curing tarps were removed and the specimens were placed in various field curing conditions.

Only one break schedule is required because the curing operations at a prestressed plant are under controlled conditions and are similar year round. Therefore, as explained in Section 4.5.4, the recommended testing ages for a prestressed operation are 6, 12, and 24 hours, and 3, 7, and 28 days. The specimens should follow the same curing procedure used to cure the girder until the accelerated curing method is completed. On completion, the specimens can be moved to a lime-saturated water-tank in the prestressed yard.

When the concrete for S-M relationship specimens is batched, the fresh concrete properties should be tested to ensure that the concrete being produced meets all ALDOT Specification requirements. A sufficient batch size should be produced to cast specimens

used to create the S-M relationship. This will ensure that the consistency of the concrete used to cast specimens will be consistent with the concrete used on the construction site. The Texas specification (Tex-426-A 2004) requires a minimum of 4 yd³ be produced, while the Iowa (IM 383 2004) specification requires a minimum of 3 yd³. From experience and lessons learned on the I-85 and US 29 bridge deck project, a batch size of 3 yd³ is recommended so that construction procedures, such as adding water at the construction site, can be performed properly.

Along with the strength data, specimen temperature history data are needed to develop the S-M relationship. Texas and Iowa specifications require that two temperature thermocouple probes be embedded into two different specimens and the average of the two temperature histories be used to calculate the maturity index. Indiana requires only one temperature sensor to be embedded into one specimen. Iowa and Indiana allow specimens that have the thermocouple wire embedded to be strength tested for the final testing age. When the maturity of both the laboratory and field project specimens were recorded, an extra specimen was cast to record the temperatures. The specimen with the embedded temperature sensor was not used for strength testing because the temperature sensors could have affected the strength of the concrete due to the size of the sensors. It is recommended that one extra specimen be cast and two maturity recording devices be embedded in it. The average maturity from the two recording devices should be used to develop the S-M relationship.

Once all the strength data and corresponding maturity indices have been collected, the S-M relationship can be developed. As discussed in Section 2.4, the exponential and hyperbolic functions are the best for modeling the strength development of concrete. The

exponential function was used for both field projects, and modeled the strength development of the concrete accurately. In all field projects, an R^2 value of 0.98 or more was obtained when the exponential function was used to define the S-M relationship. Therefore, the exponential function is recommended for use to develop the S-M relationship. Using a computer program and regression analysis, the best-fit exponential values can be found for a concrete mixture. The R^2 value should not be less than 0.95 or else the S-M relationship should be redeveloped. Figure 6-2 illustrates a S-M relationship using the exponential function. It is recommended to add confidence levels to the best-fit S-M relationship.

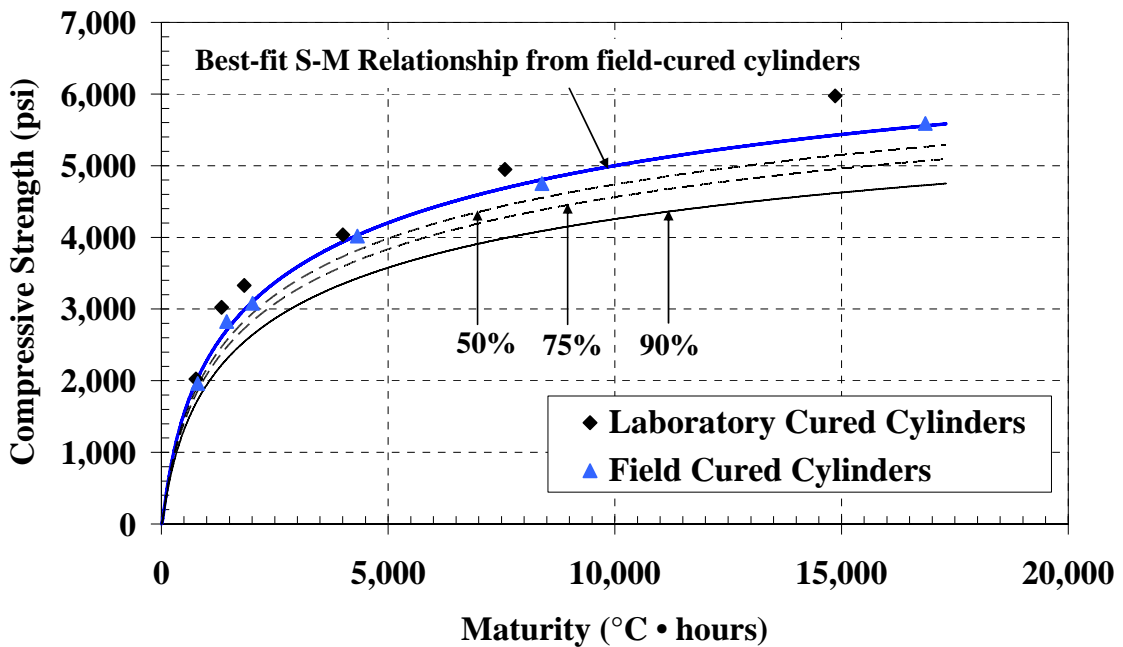

Figure 6-2: S-M relationship with confidence levels of field-cured specimens

ASTM C 1074 (2004) does not require the addition of confidence levels; however, it requires that a new S-M relationship be developed if the error between the estimated strength from the S-M relationship and the average measured strength from the

verification test consistently exceeds 10%. The S-M relationship is developed from an average strength, which is a 50% confidence that 50% of the test specimens will fall below the S-M relationship. Confidence levels should be applied, to achieve a confidence that the strengths of the specimens and the in-place strength of the concrete are mostly in excess of the required strength. The use of confidence levels with a 10% defect level is also required to align in-place strength estimates with the reliability and safety built into the AASHTO LRFD and ACI 318 strength design procedures. Section 2.8.1 explained how to apply confidence levels having a 10% defect level that is required for f'_c . Figure 6-2 shows the confidence level-based S-M relationships for compression tests conducted on molded cylinders.

From the results obtained from the two field projects, confidence levels would help ensure that the specified strength (or more) is reached. Confidence levels of 50% and 75% were sufficient in obtaining safe estimates of the in-place strength. The importance of obtaining the required strength will govern the confidence level that must be used. If there is a high degree of certainty required for the estimated in-place strength, a confidence level of 75% should be applied, otherwise a confidence level of 50% should be used to adjust the best-fit S-M relationship. The confidence level-based S-M relationship developed with a 10% defect level should then be the S-M relationship used for estimating and verifying concrete strengths.

The percent reduction that each confidence level, with a 10% defect level, reduces the best-fit S-M relationship was calculated using the K-values of three tests that and coefficient of variation of the field-cured cylinders (2.87%). The K-values were

multiplied by the coefficient of variation to calculate the percent reduction that should be used and these are presented in Table 6-3.

Table 6-3: The percent reduction in each confidence level with 10% defect level reduces the best-fit S-M relationship

Confidence Level	Percent Best-Fit S-M Relationship is Reduced
50%	4.34% ($\approx 5\%$)
75%	7.25% ($\approx 7.5\%$)
90%	12.35% ($\approx 12.5\%$)

The S-M relationship with a 50% confidence level with a 10% defect level for water-tank-cured molded cylinders and a 5% reduction in strength of the best-fit S-M relationship is shown in Figure 6-3. The confidence level method using a 10% defect level or a simple reduction in strength shown here should be applied to the best-fit S-M relationship.

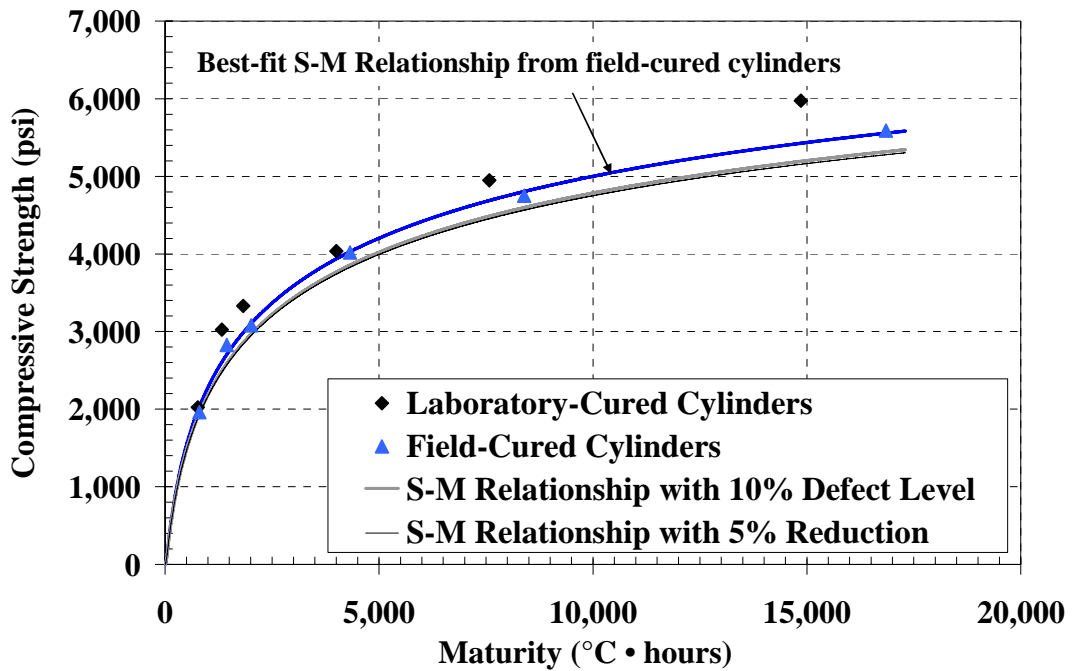

Figure 6-3: S-M relationship with 50% confidence level and 5% reduction in strength

6.2.4 ESTIMATING THE IN-PLACE STRENGTH

Estimating the in-place strength consists of installing temperature or maturity recording devices in the structure and monitoring the maturity accumulation. Temperature sensors should be installed in the structure where critical strength estimates are required, either due to structure design or exposure conditions (ASTM C 1074 2004). The engineer, the specification, or appropriate ALDOT personnel should determine these critical locations.

For pavements and bridge decks, it is recommended that at least two sensors be installed per day near the end of the day's placement. This placement method improves the accuracy of the estimation of when the day's placement has reached the required strength. If it is critical to apply construction loads as soon as possible, more sensors should be installed to achieve accurate strength estimates at multiple locations. The location of the sensors should be toward the bottom outside edges of the pavements. This will record the most accurate temperatures due to the hydration of the concrete and not the affects that the environmental conditions have on the concrete temperatures. From what was discovered on the bridge deck projects discussed in Section 5.8.5, the location of the sensors for a bridge deck should be near the bottom, near the overhang, where winds and other environmental conditions can affect the temperature of the concrete in comparison with concrete located in the middle of the bridge deck. It is recommended that the sensor be placed 10 feet from the end of the day's production or in the last batch of the day. The sensors are to be embedded 2 inches from the bottom of a pavement or bridge deck (or at the bottom mat of steel for bridge decks), or at mid-depth if the slab is less than 4 inches, and about 1 ½ feet from the longitudinal edge of the bridge deck or pavement.

As discussed in Section 4.5.5 the temperature sensors should be placed where the minimum temperatures are recorded in a prestressed precast girder. In the prestressed project, this location was determined to be at the ends of the girder, in the bottom flange near the surface of the concrete. The temperature sensor should not be in any location that compromises the structural integrity of the prestressed girder. It is recommended that at least two sensors be placed on each steam bed, one at each end, so that the strength can be estimated at both ends.

The temperature sensor should not be in contact with the steel. This can be achieved by attaching the sensor to insulated wires that are tightened between two reinforcement bars, which is shown in Figure 6-4.



Figure 6-4: Suspending the maturity recording device between reinforcement bars

Once the maturity of the in-place concrete has reached the maturity that corresponds to the required strength, verification of the concrete strength must be

conducted to ensure that the required strength has been achieved. This is discussed in the following section. If the error of the strength estimation obtained by the maturity method is more than +5%, then the in-place concrete is deemed to have insufficient strength. If the maturity method is to be used for critical construction processes where structural integrity is at risk, the construction process can continue if the verification test results is within 5% of the estimated strength. If the estimated strength exceeds the verification test result by more than 5% strength, then the other three cylinders that were made should be tested at a later time to determine if the concrete has met the required strength, as was the practice before the maturity method was used.

6.2.5 VERIFYING THE STRENGTH-MATURITY RELATIONSHIP

In order to use the maturity method accurately, a verification of the S-M relationship should be conducted. As discussed in Section 2.5 other factors besides temperature can affect the strength of the concrete. Therefore, some type of verification test must be performed to ensure that the concrete delivered to site is of the same quality as the concrete used to develop the S-M relationship. ASTM C 1074 (2004) allows molded cylinders from concrete being placed in the structure to be used for verification testing.

After the temperature sensors installed in the structure are covered with concrete, a sample of that concrete should be used to make molded cylinders. Fresh concrete properties should be tested to ensure that ALDOT's specifications are met. It is recommended that a minimum of six 6 x 12 inch cylinders be made for compression strength testing along with an extra cylinder with a temperature sensor installed. Field curing in a lime-saturated water-tank should be used to cure these specimens.

Once the maturity of the structure or the molded specimens has reached the maturity corresponding to the required strength, the specimens are to be strength tested. The average strength of the three specimens, removing any outliers, is then compared to the estimated strength from the S-M relationship at the maturity index of the specimens. If percent error of the strength estimate is equal to or above -5% then the estimated strength can be considered accurate. Once the in-place concrete achieves the required strength, the concrete is assumed to have adequate strength.

If the S-M relationship with a 10% defect level is valid for the concrete being placed in the structure, the majority of the verification strength tests should exceed strengths estimated by the maturity method. Only one out of every ten verification tests should be below the estimated strength from the S-M relationship developed at a 10% defect level. TxDOT (Tex-426-A 2004) requires that if three consecutive verification test results differs between 5% and 10% of the estimated strength from the best-fit S-M relationship, then the S-M relationship must be mathematically adjusted and redevelopment is not required. The purpose of this requirement is to identify potential problems that could occur with the concrete being placed before the problems become too severe. Statistically, three consecutive verification tests should not fall between 5% to 10% below the estimated strength from the S-M relationship with a 10% defect level.

A final recommendation is provided that if a single verification test (average of three cylinders) is more than 10% below the estimated strength from the S-M relationship with a 10% defect level, the S-M relationship must be discarded, as it is not representative of the concrete delivered to site, and a new S-M relationship must be developed. A new S-M relationship must also be developed if three consecutive

verification test results fall in the range of 5% to 10% below the estimated strength from the S-M relationship with 10% defect level. The use of a confidence level-based S-M relationship should minimize the likelihood that the situation will occur that requires that the S-M relationship be redeveloped.

6.3 SUMMARY

An outline of the proposed specification (Appendix D) can be found in Section 7.4. Final details and procedures shall be approved by ALDOT. The proposed specification was written to employ the testing procedures currently implemented by ALDOT. Minor changes can be incorporated in the testing procedure to comply with existing ALDOT practices and specifications. Most maturity method specifications should have the following as the three main components, (1) developing the S-M relationship, (2) estimating the in-place strength, and (3) verifying the S-M relationship.

CHAPTER 7

CONCLUSIONS AND RECOMMENDATIONS

The maturity method is a simple and effective way to estimate the early-age strength development associated with concrete applications. The Nurse-Saul maturity method is a simple function that takes into account the concrete age and the temperature of the concrete above a datum temperature.

Later, Freiesleben Hansen and Pederson (1977) developed a maturity function called the Arrhenius maturity function. The Arrhenius maturity function has become the preferred maturity function for researchers, while the Nurse-Saul maturity function is preferred for construction practice because of the simplicity of the function. However, both functions have inherent limitations that must be recognized. Today the maturity method is used in the United States by the departments of transportation of some states such as Texas, Iowa, Indiana, Pennsylvania, Colorado, and South Dakota. The purpose of this project was to evaluate the accuracy of the maturity method in field applications. In order to do so, the method was evaluated using actual construction operations at a precast prestressed plant and the construction of a bridge deck.

In order to evaluate the maturity method, actual field construction projects were used to simulate the most accurate conditions that would be encountered when using the maturity method. The ASTM C 1074 (2004) specification was tested for both projects to

evaluate the accuracy of the specification. ASTM requires the use of laboratory-cured specimens to develop the strength-maturity relationship. In addition the use of two field-curing methods were evaluated to determine if a field-curing method was more accurate at estimating the in-place strength of the concrete. In-place tests were also conducted to evaluate the accuracy of the maturity method to estimate the in-place strength of the concrete. The ideal locations for the temperatures sensors were also evaluated by placing many sensors in the precast prestressed girder and bridge deck to monitor the temperature development of the concrete.

The precast prestressed girder project was conducted first with the cooperation of Sherman Prestress Plant in Pelham, Alabama. The field project was conducted on a steam-curing bed at their facility. To develop the strength-maturity relationship, three sets of molded cylinders were made and cured using three different curing methods. The curing methods evaluated were laboratory-cured specimens, a field-cured lime-saturated water-tank, and a field-cured damp-sand-pit. The testing schedule for the laboratory-cured cylinders was 11, 20, 34, 42, and 66 hours, and 4, 7, and 28 days. For both field-cured cylinder sets, the testing schedule was 8, 12, 18, 24, and 48 hours and 4, 7, and 28 days. At each testing age, three cylinders were compression tested. The temperature histories of all molded specimens were recorded.

A 19 foot mock girder was produced so that multiple in-place tests could be conducted. For this project the in-place strengths were evaluated using the pullout test and the compressive testing of cores. The pullout test was conducted on the top and sides of the mock girder at the testing ages of 12, 18, 24, and 48 hours, and 7 and 28 days. Cores were tested in compression at 7 and 28 days. The ASTM C 42 (2004) and

AASHTO T 24 (2002) testing methods for removal and preparation of the cores were both evaluated. In order to assess the accuracy of the pullout table supplied by Germann Instruments, correlate the measured pullout force to the compressive strength of 6 x 12 inch molded cylinders, pullout tests were performed on cube specimens. The testing ages for the pullout test performed on the cubes were 18 hours, 48 hours, and 7 day. Also 46 temperature sensors were placed throughout the girder to capture the temperature development of the concrete. The temperature history of all molded specimens and the mock bridge deck were recorded.

The second field project that was evaluated was the bridge deck project at the I-85 and US 29 interchange in Auburn, Alabama. This project was divided into two separate evaluations. The first evaluation was similar to the precast prestressed girder project where two mock bridge decks were constructed and in-place testing was conducted, and the second evaluation was to assess the accuracy of using molded cylinders for verification testing.

A mock bridge deck was conducted twice, once in the winter and once in the summer in order to evaluate the effects of the seasonal weather conditions on the maturity method. Only two curing methods were evaluated for the cylinders used to develop the strength-maturity relationships. These curing methods were the laboratory-cured specimens and the field-cured lime-saturated water-tank. The testing ages for both the laboratory and field cured specimens were 1, 2, 3, 7, 14, and 28 days. At each testing age three cylinders were compression tested. The in-place tests conducted on the mock bridge deck were the pullout test, cast-in-place cylinders, and compressive testing of cores. The pullout test was conducted on the top, side, and bottom on the mock bridge deck at the

ages of 1, 2, 3, 7, 14, and 28 days. The compressive strength of cast-in-place cylinders was tested at the ages of 1, 2, 7, and 28 days. The compressive strength of cores was conducted at the ages of 7 and 28 days. Again both the ASTM C 1074 (2004) and AASHTO T 24 (2002) testing methods were evaluated.

The second evaluation of the bridge deck project was to evaluate the use of molded specimens to verify the strength estimated by the maturity method. In this phase the actual bridge deck being constructed was tested. Two bridge decks were evaluated; the first bridge was the US 29 southbound lanes being constructed over I-85 and the other was the US 29 southbound lanes being constructed over the Parkerson Creek. Temperature sensors were placed throughout both bridge decks to determine the best location for the sensors. No in-place testing was conducted on the actual bridge deck.

7.1 CONCLUSIONS

After all of the field projects were concluded the accuracy of the maturity method was analyzed. The conclusions that were found are as follows:

- The results of the laboratory and field studies indicated that the maturity method may only be accurate up until an equivalent age of 7 days.
- The field-cured strength-maturity relationship for both the precast prestressed girder project and the bridge deck project were more accurate in assessing the in-place strength as compared to using the laboratory-cured strength-maturity relationship.

The conclusions on the accuracy of the maturity method using the common temperature sensitivity values for the two maturity functions are as follows:

- When comparing the datum temperature for the Nurse-Saul maturity function, the datum temperature of 0 °C was, in most cases, more accurate than the datum temperature of -10 °C.
- For the Arrhenius maturity function the activation energy of 33,500 J/mol was more accurate for the warm-weather placement of the mock bridge deck and the prestressed girder, and the activation energy of 40,000 J/mol was more accurate for the cold-weather placement of the mock bridge deck. This supports the results that were found in the laboratory phase of this project.
- When considering all of the results from the laboratory study, the prestressed project, both the mock bridge decks, and the evaluation of the use of molded cylinders for verification testing, the Nurse-Saul maturity function with a datum temperature of 0 °C was the most accurate at estimating the strength of the concrete under all conditions.

The conclusions of the accuracy of the maturity method to estimate the in-place strength are as follows:

- The pullout table provided by Germann Instrument with the Lok-Test is accurate for estimating the strength of the concrete that was tested for these two projects.
- The maturity method estimated the in-place strength provided by the pullout test accurately for both projects.

- The maturity method estimated the compression strength of the cast-in-place cylinders within an acceptable degree of accuracy for both placements of the mock bridge deck.
- From the bridge deck study the pullout test and cast-in-place cylinder both accurately assessed the in-place strength of the concrete for both mock bridge decks.
- The maturity method did not accurately estimate the compression strength of cores obtained from either the prestressed girder project or the warm-weather placement of the mock bridge deck. It did accurately estimate compression strength of cores obtained from the cold-weather mock bridge strength. Since the pullout test and cast-in-place cylinders accurately assess the in-place strength, this error is believed to be attributed to the low strengths that have been reported for core testing.

The conclusions on the location of sensors to record the concrete temperatures in the structure are as follows:

- The optimum location for the temperature sensors in the structure is the area where the lowest temperature developments are found. These areas would have the lowest maturity and thus the slowest strength development
- For the prestressed girder it was found that the lowest temperatures developed in the bottom flange near the outside surface at the ends of the girder.
- For the bridge deck application it was found that the lowest temperatures were the overhang of the bridge deck.

- The temperature sensors should not be attached directly to the steel because the temperature of the steel will affect the temperature recorded by the sensor.

The conclusions on the testing schedule for developing the strength-maturity relationship are as follows:

- Since the field-cured specimens were more accurate at estimating the in-place strength, the testing schedule for developing the strength-maturity relationship should reflect the field-cured temperature histories.
- Testing only until an equivalent age of 7 days is needed to develop the strength-maturity relationship.
- A 28-day testing age should be conducted to help define the strength plateau of the concrete and assess whether the concrete used to develop the strength-maturity relationship meets the specified strength.
- For prestressed girder applications, one fixed field-cured testing schedule will be adequate since the prestressed girder curing histories are controlled and are similar year round.
- For bridge deck applications the testing schedule should depend on the initial ambient temperatures after the concrete was placed.

The conclusions on the evaluation of the used of molded cylinder for verification testing to implement the maturity method on the construction site are as follows:

- The use of molded cylinders for verification test recommended in Section 9.5.4 of ASTM C 1074 is a valid test to evaluate the strength when using the maturity method.
- Confidence levels of 50% and a defect level of 10% should be applied to the strength-maturity relationship to account for the variability of the concrete strength results. The use of confidence levels with a 10% defect level is also required to align in-place strength estimates with the reliability and safety built into the AASHTO LRFD and ACI 318 strength design procedures.
- If the verification test is -5% or above the estimated strength from the strength-maturity relationships with a 10% defect level then the required strength is considered to be achieved and the construction operations shall continue.
- If the verification test is below -5% of the estimated strength from the strength-maturity relationships with a 10% defect level then the construction operation shall not continue until the strength has been verified by testing more specimens at a later time.
- If the error between the verification test and the estimated strength from the strength-maturity relationship with 10% defect levels is larger than 10% or three consecutive verification tests are within a 5% to 10% difference of the estimated strength, then a new strength-maturity relationship has to be developed.

7.2 RECOMMENDATIONS

From the analysis of the two field projects and the laboratory results, the following recommendations were made for the proposed ALDOT maturity specification which is presented in Appendix D. The general recommendations for the specification are:

- Use the Nurse-Saul maturity function with at datum temperature of 0 °C.
- Use commercially available maturity recording devices that automatically calculated and display the maturity index. The temperature sensitivity for the recording device be ± 1 °C.
- The time interval for recording shall be every ½ hour for the first 24 hours, and every 1 hour for thereafter. Shorter time interval shall be allowed.
- One maturity recording device is required at each location where a strength estimate is required.

The recommendations for developing the strength-maturity relationship are as follows:

- Prepare a minimum of 16 cylinders concrete mixture for used for pavements and bridge deck construction.
- Prepare a minimum of 19 cylinders for concrete mixture used in a precast prestress application.
- A minimum batch size of 3 yd³ is required.
- Fresh concrete testing shall be performed for each batch where the maturity method is used.
- Two sensors shall be embedded in the center of one of the molded specimens.

- For the first 24 to 48 hours, the molded specimens, with plastic lids, are to remain outside exposed to ambient temperature conditions and out of direct sunlight.
- After the 24 hours, specimens are to be removed from the molds and immersed into a water bath saturated with calcium hydroxide that is exposed to ambient temperature conditions and direct sun light until the time of testing.
- Testing ages for concrete used for bridge construction, mainline pavements, or patches are a factor of the ambient temperatures. The recommended testing schedule is contained in Table 6-2.
- The testing ages for the construction of precast prestressed girders are 6, 12, and 24 hours and 3, 7, and 28 days.
- The best-fit strength-maturity relationship should be calculated using the exponential strength-maturity function, and the R^2 value should not be less than 0.95.
- Once the best-fit strength-maturity function has been determined it should be reduced by 5%. The resulting curve is the strength-maturity relationship to be used for estimating the strength of the concrete mixture placed in the field.

The recommendations for estimating the in-place strength of the concrete are as follows:

- Install a minimum of two maturity sensor at locations in the structure that are critical to the structural considerations or exposure conditions.

- In concrete pavement applications and bridge deck placement, a minimum of 2 temperature sensors will be placed 10 feet from the termination of the day's production or in the last patch of the day. Maturity sensors shall be placed 2 inches from bottom forms or surface, or at mid-depth of the section for sections less than 4 inches. The sensors shall also be placed 1 ½ feet from the transverse edge of the pavement or bridge deck.
- For bridge substructure elements, such as columns, column caps, and diaphragms, 2 sensors shall be installed 2 to 4 inches from the surface of the upper corner.
- For precast prestressed girder construction applications, 2 temperature sensors shall be positioned near the outer surface of the lower flange at the ends of the girder.
- Maturity sensors may be tied to reinforcing steel but should not be in direct contact with the reinforcing steel or formwork.
- Verification tests are required to ensure that in-place strength is sufficient and that the strength-maturity relationship is indeed valid for the concrete delivered to site.
- If the error of estimated strength obtained by the maturity method is 5% or less than the measured strength then the in-place concrete is deemed to have sufficient strength.

The recommendations for the verification testing are as follows:

- Make a minimum of seven cylinders for every location in the structure where maturity probes are installed.
- Embed two maturity sensors in one specimen.
- The verification test specimens are to be cured the same way the specimens used to develop the strength-maturity relationship were cured.
- Compression tests are to be performed when the specimen achieves the maturity corresponding to the required strength, or when the corresponding maturity of the member is achieved in the field. Determine the compressive strength of three cylinders and compute the average strength of the specimens.
- If the error between the estimated strength obtained from the strength-maturity relationship with a 10% defect level and measured strength of the verification test exceeds +10% or if three consecutive errors obtained fall between +5% and +10%, then a new strength-maturity relationship shall be developed.

REFERENCES

- AASHTO LRFD Bridge Construction Specification. 2004 American Association of State Highway and Transportation Officials. Washington D.C
- AASHTO T 119. 2005. Slump of Hydraulic Cement. American Association of State Highway and Transportation Officials. Washington D.C.
- AASHTO T 141. 2005. Sampling Freshly Mixed Concrete. American Association of State Highway and Transportation Officials. Washington D.C.
- AASHTO T 152. 2005. Air Content of Freshly Mixed Concrete by the Pressure Method. American Association of State Highway and Transportation Officials. Washington D.C.
- AASHTO T 22. 2005. Compressive Strengths of Cylindrical Concrete Specimens. American Association of State Highway and Transportation Officials. Washington D.C.
- AASHTO T 23. 2004. Making and Curing Concrete Test Specimens in the Field. American Association of State Highway and Transportation Officials. Washington D.C.
- AASHTO T 231. 2005. Capping Cylindrical Concrete Specimens. American Association of State Highway and Transportation Officials. Washington D.C

- AASHTO T 24. 2002. Obtaining and Testing Drilled Cores and Sawed Beams of Concrete. American Association of State Highway and Transportation Officials. Washington D.C.
- AASHTO T 309. 2005. Temperature of Freshly Mixed Hydraulic Cement Concrete. American Association of State Highway and Transportation Officials. Washington D.C.
- ACI 214. 1997. *Evaluation of Strength Testing of Concrete*. Reported by ACI Committee 214. Farmington Hills, MI: American Concrete Institute.
- ACI 228.1R. 2003. *In-Place Methods of Estimate Concrete Strength*. Reported by ACI Committee 228. Farmington Hills, MI: American Concrete Institute.
- ACI 318. 2002. Building Code Requirements for Structural Concrete (ACI 318-02 and Commentary (ACI 318R-02)). Reported by ACI Committee 318. Farmington Hills, MI: American Concrete Institute.
- ALDOT Section 501. 2002. Structural Portland Cement Concrete. *Standard Specification for Highway Construction*. Montgomery, Alabama.
- ASTM C 1074. 2004. Standard Practice for Estimating Concrete Strength by the Maturity Method. American Society for Testing and Materials. West Conshohocken, PA.
- ASTM C 192 2002. Standard Practice for Making and Curing Concrete Test Specimens in the Laboratory. American Society for Testing and Materials. West Conshohocken, PA.
- ASTM C 31. 2003. Standard Practice for Making and Curing Concrete Test Specimens in the Field. American Society for Testing and Materials. West Conshohocken, PA.

- ASTM C 39. 2003. Standard Practice for Compressive Strength of Cylindrical Concrete Specimens. American Society for Testing and Materials. West Conshohocken, PA.
- ASTM C 42. 2004. Standard Test Method for Obtaining and Testing Drilled Cores and Sawed Beams of Concrete. American Society for Testing and Materials. West Conshohocken, PA.
- ASTM C 617. 2004. Standard Practice for Capping Cylindrical Concrete Specimens. American Society for Testing and Materials. West Conshohocken, PA.
- ASTM C 803. 2003. Standard Test Method for Penetration Resistance of Hardened Concrete. American Society for Testing and Materials. West Conshohocken, PA.
- ASTM C 873. 2004. Standard Test Method Compressive Strength of Concrete Cylinders Cast in Place in Cylindrical Molds. American Society for Testing and Materials. West Conshohocken, PA.
- ASTM C 900. 2001. Standard Test Method for Pullout Strength of Hardened Concrete. American Society for Testing and Materials. West Conshohocken, PA.
- Alexander, K. M. and Taplin, J. H. 1962. Concrete Strength, Paste Strength, Cement Hydration, and the Maturity Rule. *Australian Journal Applied Science* Vol. 13, pp. 277-284.
- Bartlett, F. M. and MacGregor, J. G. 1994. Effect of Moisture Condition on Concrete Core Strengths. *ACI Material Journal* Vol. 91, No. 3: pp. 227-236.
- Bartlett, F. M. and MacGregor, J. G. 1999. Variation of In-Place Concrete Strength in Structures. *ACI Material Journal* Vol. 96, No. 2: pp. 261-270.
- Bergstrom, S. G. 1953. Curing Temperatures, Age and Strength of Concrete. *Magazine of Concrete Research* Vol. 5, No. 14: pp. 61-66

- Bickley, J. A. 1982. The Variability of Pullout Tests and In-Place Concrete Strength. *Concrete International* Vol. 4, No. 4: pp. 44-50.
- Bloem, D. L. 1965. Concrete Strength Measurements – Cores verses Cylinders. *American Society Testing Materials* Vol. 65, pp. 668-694.
- Bloem, D. L. 1968. Concrete Strength in Structures. *ACI Journal* Vol. 26 No. 3: 176-187.
- Bungey J.H. and Soutsos, M.N. 2000. Reliability of Partially Destructive Test to Assess the Strength of Concrete on Site. In *Fifth CANMET/ACI International Conference on Durability of Concrete*. Proceedings of Special Technical Session on *Near-Surface Testing for Strength and Durability of Concrete*. Barcelona, Spain.
- Carino, N. J. 1984. The Maturity Method: Theory and Application. *ASTM Journal Cement, Concrete, and Aggregates* Vol. 6, No. 2: pp. 61-73.
- Carino, N. J. 1990. Statistical Methods to Evaluate In-Place Test Results. Proceeding Testing During Concrete Construction. Chapman and Hall.
- Carino, N. J. 1991. *Handbook on Nondestructive Testing Concrete*. Boca Raton, FL: CRC Press Inc.
- Carino, N. J. 1993. Statistical Methods to Evaluate In-Place Test Results. In *New Concrete Technology, Robert E. Philleo Symposium*. T.C Liu and G.C. Hoff, Eds. ACI Special Publication SP-141. Detroit: American Concrete Institute. pp. 39-64.
- Carino, N. J., Lew, H. S., and Volz, C. K. 1983. Early Age Temperature Effects on Concrete Strength Prediction by the Maturity Method. *ACI Journal* Vol. 80, No. 2: pp. 93-101.
- Carino, N. J., and Tank, R. C. 1992. Maturity Functions for Concrete Made with Various Cements and Admixtures. *ACI Material Journal* Vol. 89, no 2: pp. 188-196.

- Carino, N.J. 1997. Chapter 19. Nondestructive Test Methods. *Concrete Construction Engineering Handbook*. Boca Raton, FL: CRC Press. pp. 1-68.
- Copeland, L.E., Kantro, D. L., and Verdeck, G. 1962. Chemistry of Hydration of Portland Cement. Part III- Energetic of the Hydration of Portland Cement. *Proceeding of 4th International Symposium on Chemistry of Cement*. NBS Monograph Vol. 43, Washington, pp. 453-468.
- Cordon, W. A. 1946. *Investigation of the Effect of Vibration Time on the Bleeding Property of Concrete With and Without Entrained Air*. Materials Laboratories Report No. C-375. Research and Geology Division. Bureau of Reclamation. Denver. January 26.
- Enguis, 2005a. *Case Study: Interstate 40 Bridge Reconstruction; Webber Fall, Oklahoma*. <http://www.intellirock.com/resources/case_studies/I-40%20Case%20Study.pdf>
- Enguis, 2005b. *Case Study: Dallas High-Five Interchange Project; Dallas, Texas*. <http://www.intellirock.com/resources/case_studies/Zachry%20Dallas%20Hi5%20Case%20Study.pdf>
- Freiesleben Hansen, P. and Pederson, J. 1977. Maturity Computer for Controlled Curing and Hardening of Concrete. *Nordisk Betong* Vol. 1, No. 19: pp. 19-34.
- Freiesleben Hansen, P. and Pederson, J. 1984. Curing of Concrete Structures. Draft CEB-Guide to Durable Concrete Structures. Comite Euro-International Du Beton. Appendix 1. pp. 1-44.

- Gonnerman, H. F. and Shuman, E. C. 1928. Flexure and Tension Tests of Plain Concrete. Major Series 171, 209, and 210. *Report of the Director of Research*. Portland Cement Association. November. pp. 149-163.
- Hindo, K. R. and Bergstrom, W. R. 1985. Statistical Evaluation of the In-Place Compressive Strength of Concrete. *Concrete International* Vol. 7, No. 2: pp. 44-48.
- Hubler, L. 1982. Developer Saves Time, Reduces Interest Costs with New Concrete Testing System. *Canadian Building Magazine*. Jan. pp. 1-3.
- IM 383. 2004. Method of Testing the Strength of Portland Cement Concrete Using the Maturity Method. Iowa Department of Transportation.
<http://www.erl.dot.state.ia.us/Apr_2005/IM/content/383.pdf>
- INDOT Standard Specification Book. 2006. Concrete Pavement. Section 500.
<<http://www.state.in.us/dot/div/contracts/standards/book/sep06/5-2006.pdf>>.
- ITM 402-04T. 2004. Strength of Portland Cement Concrete Pavement (PCCP) Using the Maturity Method Utilizing the Time Temperature Factor Methodology. Indiana Department of Transportation Material & Tests Division.
<<http://www.in.gov/dot/div/testing/itm/402.pdf>>.
- Iowa DOT Standard Specification with GS-1009 Revisions. 2005. 2301.31 Time for Opening Pavement for Use. *Division 23 Surface Courses*.
<http://www.erl.dot.state.ia.us/Apr_2005/GS/content/2301.htm>.
- Kierkegaard-Hansen, P. 1975. Lok-Strength. *Nordisk Betong*. No. 3: pp. 19-28.
- Kierkegaard-Hansen, P and Bickley, J. A. 1978. In-Situ Strength Evaluation of Concrete by the Lok-Test System. *American Concrete Institute Fall Convention*. Houston.

- Kjellsen, K. O. and Detwiller, R. J. 1993. Later-Age Strength Prediction by a Modified Maturity Model. *ACI Material Journal* Vol. 90. No. 3: 220-227.
- Komatka, S. H., Kerkhoff, B., and Panarese, W. C. 2003. *Design and Control of Concrete Mixtures*. 14th ed. Skokie, IL. Portland Cement Association.
- Krenchel, H. and Bickley, J. A. 1987. Pullout Test of Concrete: Historical Background and Scientific Level Today. *Nordisk Betong* Publication No. 6, Nordic Concrete Research, Nordic Concrete Federation. pp. 155-168.
- Krenchel, H. and Shah, S. P. 1985. Fracture Analysis of the Pullout Test. *Materiaux et Constructions* Vol. 18, No. 108: pp. 439-446.
- Malhotra, V. M. and Carette, G. 1980. Comparison of Pullout Strength of Concrete with Compressive Strength of Cylinder and Cores, Pulse Velocity, and Rebound Number. *ACI Journal* Vol. 77, No 3: pp. 161-170.
- McIntosh, J. D. 1949. Electrical Curing of Concrete. *Magazine of Concrete Research* Vol. 1, No. 1: pp. 21-28.
- Mindess, S., Young, J. F., and Darwin, D. 2003. *Concrete* 2d ed. Upper Saddle River, NJ: Pearson Education, Inc
- Munday, J. G. and Dhir, R. K. Assessment of In Situ Concrete Quality by Core Testing. *Publication SP – American Concrete Institute*. pp. 393-410.
- Nurse, R. W. 1949. Steam Curing of Concrete. *Magazine of Concrete Research* Vol. 1, No. 2: pp. 79-88.
- Odeh, R. E. and Owen, D. B. 1980. *Tables for Normal Tolerance Limits, Sampling Plans, and Screening*. Marcel Dekker, Inc. New York, New York.

- Plowman, J. M. 1956. Maturity and the Strength of Concrete. *Magazine of Concrete Research* Vol. 8, No. 22: pp. 13-22.
- Rastrup, E. 1954. Heat of Hydration in Concrete. *Magazine of Concrete Research* Vol. 6, No. 17: pp. 79-92.
- Saul, A. G. A. 1951. Principles Underlying the Steam Curing of Concrete at Atmospheric Pressure. *Magazine of Concrete Research* Vol. 2, No. 2: pp. 127-140.
- Soutsos, M. N., Bungey, J. H., and Long, A. E. 2000. In-Situ Strength Assessment of Concrete-The European Concrete Frame Building Project. *Proceedings of the 5th International Conference on NDT in Civil Engineering*, T. Uomoto ed. Tokyo: Elsevier Science. pp. 583-592.
- Stone, W. C. and Carino, N. J. 1983. Deformation and Failure in Large-Scale Pullout Tests. *ACI Journal* Vol. 80, No. 6: pp. 501-513.
- Stone, W. C., Carino, N. J., and Reeve, C. P. 1986. Statistical Methods for In-Place Strength Prediction by the Pullout Test. *ACI Journal* Vol. 83, No. 5: pp. 745-757.
- Stone, W. C. and Giza, B. J. 1985. The Effects of Geometry and Aggregates on the Reliability of the Pullout Test. *Concrete International* Vol. 7, No. 2: pp. 27-36.
- Suprenant, B. A. 1985. An Introduction to Concrete Core Testing. *Civil Engineering for Practicing and Design Engineers* Vol. 4, pp. 607-615.
- Szypula A. and Grossman, J. S. 1990. Cylinders vs. Core Strength. *Concrete International: Design and Construction* Vol. 12, No. 2: pp. 55-61.
- Tank, R. C. and Carino, N. J. 1991. Rate Constant Functions for Strength Development of Concrete. *ACI Material Journal* Vol. 88, No. 1: pp. 74-83.

- Tex-426-A. 2004. Estimating Concrete Strength by the Maturity Method. Texas Department of Transportation.
<http://manuals.dot.state.tx.us/dynaweb/colmates/cnn/@Generic__BookTextView/20016;cs=default;ts=default;pt=20016#X>.
- Topuc, İ. B. and Uğurlu, A. 2003. Effect of the Use of Mineral Filler on the Properties of Concrete. *Cement and Concrete Research* Vol. 33, pp. 1071-1075.
- VanerPol, R. II. 2004. Letters in Response to ‘Maturity Testing is the Future.’ *Concrete International* Vol. 26, No. 2: pp. 17-21.
- Wade, S. 2005. “Evaluation of the Maturity Method to Estimate Concrete Strength.” Master Thesis, Auburn University.

APPENDIX A

PULLOUT TABLE BY GERMANN INSTRUMENTS

Appendix A is the table that correlates the pullout force to compressive strength of molded cylinders. The table was provided by Germann Instruments with the Lok-Test equipment and was verified with test data gathered this research project.

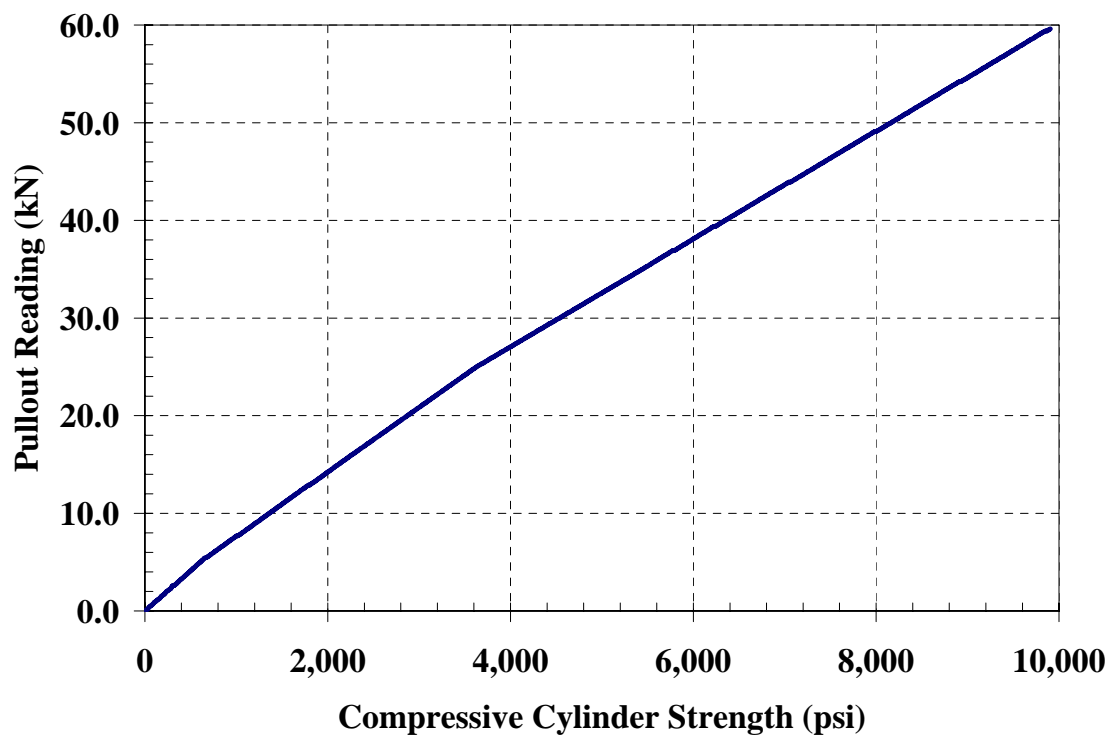

Figure A-1: Pullout reading versus compressive strength of cylinders

Table A-1: Pullout table provided by Germann Instruments

Reading (kN)	Actual Pull force (kN)	Cylinder Strength (psi)	Reading (kN)	Actual Pull force (kN)	Cylinder Strength (psi)
0.0	0.0	0	3.8	4.2	510
0.1	0.1	15	3.9	4.3	522
0.2	0.2	30	4.0	4.4	533
0.3	0.4	44	4.1	4.5	545
0.4	0.5	59	4.2	4.6	557
0.5	0.6	74	4.3	4.7	569
0.6	0.7	89	4.4	4.8	581
0.7	0.9	104	4.5	4.9	593
0.8	1.0	119	4.6	5.0	605
0.9	1.1	133	4.7	5.1	616
1.0	1.2	148	4.8	5.2	628
1.1	1.3	163	4.9	5.3	640
1.2	1.5	178	5.0	5.4	652
1.3	1.6	193	5.1	5.5	679
1.4	1.7	207	5.2	5.6	694
1.5	1.8	222	5.3	5.7	708
1.6	2.0	237	5.4	5.8	723
1.7	2.1	252	5.5	5.9	738
1.8	2.2	267	5.6	6.0	753
1.9	2.3	282	5.7	6.1	768
2.0	2.5	296	5.8	6.2	782
2.1	2.6	308	5.9	6.3	797
2.2	2.6	320	6.0	6.4	812
2.3	2.7	332	6.1	6.5	827
2.4	2.8	344	6.2	6.6	842
2.5	2.9	356	6.3	6.7	857
2.6	3.0	367	6.4	6.8	871
2.7	3.1	379	6.5	6.9	886
2.8	3.2	391	6.6	7.0	901
2.9	3.3	403	6.7	7.1	916
3.0	3.4	415	6.8	7.2	931
3.1	3.5	427	6.9	7.3	945
3.2	3.6	439	7.0	7.4	960
3.3	3.7	450	7.1	7.5	975
3.4	3.8	462	7.2	7.6	990
3.5	3.9	474	7.3	7.7	1,005
3.6	4.0	486	7.4	7.7	1,020
3.7	4.1	498	7.5	7.8	1,034

Table A-1: Pullout table provided by Germann Instruments (continued)

Reading (kN)	Actual Pull force (kN)	Cylinder Strength (psi)	Reading (kN)	Actual Pull force (kN)	Cylinder Strength (psi)
7.6	7.9	1,049	11.4	11.7	1,612
7.7	8.0	1,064	11.5	11.8	1,627
7.8	8.1	1,079	11.6	11.9	1,642
7.9	8.2	1,094	11.7	12.0	1,657
8.0	8.3	1,108	11.8	12.1	1,671
8.1	8.4	1,123	11.9	12.2	1,686
8.2	8.5	1,138	12.0	12.3	1,701
8.3	8.6	1,153	12.1	12.4	1,716
8.4	8.7	1,168	12.2	12.5	1,731
8.5	8.8	1,183	12.3	12.6	1,746
8.6	8.9	1,197	12.4	12.7	1,760
8.7	9.0	1,212	12.5	12.8	1,775
8.8	9.1	1,227	12.6	12.9	1,790
8.9	9.2	1,242	12.7	12.9	1,805
9.0	9.3	1,257	12.8	13.0	1,820
9.1	9.4	1,271	12.9	13.1	1,834
9.2	9.5	1,286	13.0	13.2	1,849
9.3	9.6	1,301	13.1	13.3	1,864
9.4	9.7	1,316	13.2	13.4	1,879
9.5	9.8	1,331	13.3	13.5	1,894
9.6	9.9	1,345	13.4	13.6	1,909
9.7	10.0	1,360	13.5	13.7	1,923
9.8	10.1	1,375	13.6	13.8	1,938
9.9	10.2	1,390	13.7	13.9	1,953
10.0	10.3	1,405	13.8	14.0	1,968
10.1	10.4	1,420	13.9	14.1	1,983
10.2	10.5	1,434	14.0	14.2	1,997
10.3	10.6	1,449	14.1	14.3	2,012
10.4	10.7	1,464	14.2	14.4	2,027
10.5	10.8	1,479	14.3	14.5	2,042
10.6	10.9	1,494	14.4	14.6	2,057
10.7	11.0	1,508	14.5	14.7	2,072
10.8	11.1	1,523	14.6	14.8	2,086
10.9	11.2	1,538	14.7	14.9	2,101
11.0	11.3	1,553	14.8	15.0	2,116
11.1	11.4	1,568	14.9	15.1	2,131
11.2	11.5	1,583	15.0	15.2	2,146
11.3	11.6	1,597	15.1	15.3	2,161

Table A-1: Pullout table provided by Germann Instruments (continued)

Reading (kN)	Actual Pull force (kN)	Cylinder Strength (psi)	Reading (kN)	Actual Pull force (kN)	Cylinder Strength (psi)
15.2	15.4	2,176	19.0	19.2	2,750
15.3	15.5	2,191	19.1	19.3	2,765
15.4	15.6	2,206	19.2	19.4	2,780
15.5	15.7	2,221	19.3	19.5	2,796
15.6	15.8	2,236	19.4	19.6	2,811
15.7	15.9	2,251	19.5	19.7	2,826
15.8	16.0	2,267	19.6	19.8	2,841
15.9	16.1	2,282	19.7	19.9	2,856
16.0	16.2	2,297	19.8	20.0	2,871
16.1	16.3	2,312	19.9	20.1	2,886
16.2	16.4	2,327	20.0	20.2	2,901
16.3	16.5	2,342	20.1	20.3	2,916
16.4	16.6	2,357	20.2	20.4	2,932
16.5	16.7	2,372	20.3	20.5	2,947
16.6	16.8	2,387	20.4	20.6	2,962
16.7	16.9	2,403	20.5	20.7	2,977
16.8	17.0	2,418	20.6	20.8	2,992
16.9	17.1	2,433	20.7	20.9	3,007
17.0	17.2	2,448	20.8	21.0	3,022
17.1	17.3	2,463	20.9	21.1	3,037
17.2	17.4	2,478	21.0	21.2	3,052
17.3	17.5	2,493	21.1	21.3	3,068
17.4	17.6	2,508	21.2	21.4	3,083
17.5	17.7	2,523	21.3	21.5	3,098
17.6	17.8	2,539	21.4	21.6	3,113
17.7	17.9	2,554	21.5	21.7	3,128
17.8	18.0	2,569	21.6	21.8	3,143
17.9	18.1	2,584	21.7	21.9	3,158
18.0	18.2	2,599	21.8	22.0	3,173
18.1	18.3	2,614	21.9	22.1	3,188
18.2	18.4	2,629	22.0	22.2	3,204
18.3	18.5	2,644	22.1	22.3	3,219
18.4	18.6	2,659	22.2	22.4	3,234
18.5	18.7	2,675	22.3	22.5	3,249
18.6	18.8	2,690	22.4	22.6	3,264
18.7	18.9	2,705	22.5	22.7	3,279
18.8	19.0	2,720	22.6	22.8	3,294
18.9	19.1	2,735	22.7	22.9	3,309

Table A-1: Pullout table provided by Germann Instruments (continued)

Reading (kN)	Actual Pull force (kN)	Cylinder Strength (psi)	Reading (kN)	Actual Pull force (kN)	Cylinder Strength (psi)
22.8	23.0	3,324	26.6	26.8	3,954
22.9	23.1	3,340	26.7	26.9	3,972
23.0	23.2	3,355	26.8	27.0	3,990
23.1	23.3	3,370	26.9	27.1	4,008
23.2	23.4	3,385	27.0	27.2	4,026
23.3	23.5	3,400	27.1	27.3	4,044
23.4	23.6	3,415	27.2	27.4	4,062
23.5	23.7	3,430	27.3	27.5	4,081
23.6	23.8	3,445	27.4	27.6	4,099
23.7	23.9	3,460	27.5	27.7	4,117
23.8	24.0	3,476	27.6	27.8	4,135
23.9	24.1	3,491	27.7	27.9	4,153
24.0	24.2	3,506	27.8	28.0	4,171
24.1	24.3	3,521	27.9	28.1	4,189
24.2	24.4	3,536	28.0	28.2	4,207
24.3	24.5	3,551	28.1	28.3	4,226
24.4	24.6	3,566	28.2	28.4	4,244
24.5	24.7	3,581	28.3	28.5	4,262
24.6	24.8	3,597	28.4	28.6	4,280
24.7	24.9	3,612	28.5	28.7	4,298
24.8	25.0	3,627	28.6	28.8	4,316
24.9	25.1	3,645	28.7	28.9	4,334
25.0	25.2	3,663	28.8	29.0	4,353
25.1	25.3	3,682	28.9	29.1	4,371
25.2	25.4	3,700	29.0	29.2	4,389
25.3	25.5	3,718	29.1	29.3	4,407
25.4	25.6	3,736	29.2	29.4	4,425
25.5	25.7	3,754	29.3	29.5	4,443
25.6	25.8	3,772	29.4	29.6	4,461
25.7	25.9	3,790	29.5	29.7	4,480
25.8	26.0	3,808	29.6	29.8	4,498
25.9	26.1	3,827	29.7	29.9	4,516
26.0	26.2	3,845	29.8	30.0	4,534
26.1	26.3	3,863	29.9	30.1	4,552
26.2	26.4	3,881	30.0	30.2	4,570
26.3	26.5	3,899	30.1	30.3	4,588
26.4	26.6	3,917	30.2	30.4	4,606
26.5	26.7	3,935	30.3	30.5	4,625

Table A-1: Pullout table provided by Germann Instruments (continued)

Reading (kN)	Actual Pull force (kN)	Cylinder Strength (psi)	Reading (kN)	Actual Pull force (kN)	Cylinder Strength (psi)
30.4	30.6	4,643	34.2	34.4	5,332
30.5	30.7	4,661	34.3	34.5	5,350
30.6	30.8	4,679	34.4	34.6	5,368
30.7	30.9	4,697	34.5	34.7	5,386
30.8	31.0	4,715	34.6	34.8	5,404
30.9	31.1	4,733	34.7	34.9	5,423
31.0	31.2	4,752	34.8	35.0	5,441
31.1	31.3	4,770	34.9	35.1	5,459
31.2	31.4	4,788	35.0	35.2	5,477
31.3	31.5	4,806	35.1	35.3	5,494
31.4	31.6	4,824	35.2	35.4	5,512
31.5	31.7	4,842	35.3	35.5	5,529
31.6	31.8	4,860	35.4	35.6	5,547
31.7	31.9	4,878	35.5	35.7	5,564
31.8	32.0	4,897	35.6	35.8	5,582
31.9	32.1	4,915	35.7	35.9	5,599
32.0	32.2	4,933	35.8	36.0	5,616
32.1	32.3	4,951	35.9	36.1	5,634
32.2	32.4	4,969	36.0	36.2	5,651
32.3	32.5	4,987	36.1	36.3	5,669
32.4	32.6	5,005	36.2	36.4	5,686
32.5	32.7	5,024	36.3	36.5	5,704
32.6	32.8	5,042	36.4	36.6	5,721
32.7	32.9	5,060	36.5	36.7	5,738
32.8	33.0	5,078	36.6	36.8	5,756
32.9	33.1	5,096	36.7	36.9	5,773
33.0	33.2	5,114	36.8	36.9	5,791
33.1	33.3	5,132	36.9	37.0	5,808
33.2	33.4	5,151	37.0	37.1	5,825
33.3	33.5	5,169	37.1	37.2	5,843
33.4	33.6	5,187	37.2	37.3	5,860
33.5	33.7	5,205	37.3	37.4	5,878
33.6	33.8	5,223	37.4	37.5	5,895
33.7	33.9	5,241	37.5	37.6	5,913
33.8	34.0	5,259	37.6	37.7	5,930
33.9	34.1	5,277	37.7	37.8	5,947
34.0	34.2	5,296	37.8	37.9	5,965
34.1	34.3	5,314	37.9	38.0	5,982

Table A-1: Pullout table provided by Germann Instruments (continued)

Reading (kN)	Actual Pull force (kN)	Cylinder Strength (psi)	Reading (kN)	Actual Pull force (kN)	Cylinder Strength (psi)
38.0	38.1	6,000	41.8	41.8	6,668
38.1	38.2	6,017	41.9	41.9	6,686
38.2	38.3	6,035	42.0	42.0	6,704
38.3	38.4	6,052	42.1	42.1	6,722
38.4	38.5	6,069	42.2	42.2	6,739
38.5	38.6	6,087	42.3	42.3	6,757
38.6	38.7	6,104	42.4	42.4	6,775
38.7	38.8	6,122	42.5	42.5	6,793
38.8	38.9	6,139	42.6	42.6	6,811
38.9	39.0	6,157	42.7	42.7	6,828
39.0	39.1	6,174	42.8	42.8	6,846
39.1	39.2	6,191	42.9	42.9	6,864
39.2	39.3	6,209	43.0	43.0	6,882
39.3	39.4	6,226	43.1	43.1	6,899
39.4	39.4	6,244	43.2	43.2	6,917
39.5	39.5	6,261	43.3	43.3	6,935
39.6	39.6	6,279	43.4	43.4	6,953
39.7	39.7	6,296	43.5	43.5	6,971
39.8	39.8	6,313	43.6	43.6	6,988
39.9	39.9	6,331	43.7	43.7	7,006
40.0	40.0	6,348	43.8	43.8	7,024
40.1	40.1	6,366	43.9	43.9	7,042
40.2	40.2	6,384	44.0	43.9	7,059
40.3	40.3	6,402	44.1	44.0	7,077
40.4	40.4	6,419	44.2	44.1	7,095
40.5	40.5	6,437	44.3	44.2	7,113
40.6	40.6	6,455	44.4	44.3	7,131
40.7	40.7	6,473	44.5	44.4	7,148
40.8	40.8	6,490	44.6	44.5	7,166
40.9	40.9	6,508	44.7	44.6	7,184
41.0	41.0	6,526	44.8	44.7	7,202
41.1	41.1	6,544	44.9	44.8	7,219
41.2	41.2	6,562	45.0	44.9	7,237
41.3	41.3	6,579	45.1	45.0	7,255
41.4	41.4	6,597	45.2	45.1	7,273
41.5	41.5	6,615	45.3	45.2	7,291
41.6	41.6	6,633	45.4	45.3	7,308
41.7	41.7	6,651	45.5	45.4	7,326

Table A-1: Pullout table provided by Germann Instruments (continued)

Reading (kN)	Actual Pull force (kN)	Cylinder Strength (psi)	Reading (kN)	Actual Pull force (kN)	Cylinder Strength (psi)
45.6	45.5	7,344	49.4	49.2	8,020
45.7	45.6	7,362	49.5	49.3	8,037
45.8	45.7	7,380	49.6	49.4	8,055
45.9	45.8	7,397	49.7	49.5	8,073
46.0	45.9	7,415	49.8	49.6	8,091
46.1	46.0	7,433	49.9	49.7	8,109
46.2	46.1	7,451	50.0	49.8	8,126
46.3	46.2	7,468	50.1	49.9	8,144
46.4	46.3	7,486	50.2	50.0	8,162
46.5	46.4	7,504	50.3	50.1	8,180
46.6	46.5	7,522	50.4	50.2	8,197
46.7	46.6	7,540	50.5	50.3	8,215
46.8	46.7	7,557	50.6	50.4	8,233
46.9	46.8	7,575	50.7	50.5	8,251
47.0	46.9	7,593	50.8	50.6	8,269
47.1	47.0	7,611	50.9	50.7	8,286
47.2	47.1	7,628	51.0	50.8	8,304
47.3	47.2	7,646	51.1	50.9	8,322
47.4	47.3	7,664	51.2	51.0	8,340
47.5	47.4	7,682	51.3	51.1	8,357
47.6	47.5	7,700	51.4	51.2	8,375
47.7	47.6	7,717	51.5	51.3	8,393
47.8	47.7	7,735	51.6	51.4	8,411
47.9	47.8	7,753	51.7	51.5	8,429
48.0	47.9	7,771	51.8	51.6	8,446
48.1	48.0	7,788	51.9	51.7	8,464
48.2	48.1	7,806	52.0	51.8	8,482
48.3	48.2	7,824	52.1	51.9	8,500
48.4	48.3	7,842	52.2	52.0	8,517
48.5	48.4	7,860	52.3	52.1	8,535
48.6	48.5	7,877	52.4	52.2	8,553
48.7	48.6	7,895	52.5	52.3	8,571
48.8	48.7	7,913	52.6	52.4	8,589
48.9	48.8	7,931	52.7	52.5	8,606
49.0	48.9	7,949	52.8	52.6	8,624
49.1	49.0	7,966	52.9	52.7	8,642
49.2	49.1	7,984	53.0	52.8	8,660
49.3	49.1	8,002	53.1	52.9	8,678

Table A-1: Pullout table provided by Germann Instruments (continued)

Reading (kN)	Actual Pull force (kN)	Cylinder Strength (psi)	Reading (kN)	Actual Pull force (kN)	Cylinder Strength (psi)
53.2	53.0	8,695	57.0	56.7	9,371
53.3	53.1	8,713	57.1	56.8	9,389
53.4	53.2	8,731	57.2	56.9	9,407
53.5	53.3	8,749	57.3	57.0	9,424
53.6	53.4	8,766	57.4	57.1	9,442
53.7	53.5	8,784	57.5	57.2	9,460
53.8	53.6	8,802	57.6	57.3	9,478
53.9	53.7	8,820	57.7	57.4	9,495
54.0	53.8	8,838	57.8	57.5	9,513
54.1	53.9	8,855	57.9	57.6	9,531
54.2	54.0	8,873	58.0	57.7	9,549
54.3	54.1	8,891	58.1	57.8	9,567
54.4	54.2	8,909	58.2	57.9	9,584
54.5	54.2	8,926	58.3	58.0	9,602
54.6	54.3	8,944	58.4	58.1	9,620
54.7	54.4	8,962	58.5	58.2	9,638
54.8	54.5	8,980	58.6	58.3	9,655
54.9	54.6	8,998	58.7	58.4	9,673
55.0	54.7	9,015	58.8	58.5	9,691
55.1	54.8	9,033	58.9	58.6	9,709
55.2	54.9	9,051	59.0	58.7	9,727
55.3	55.0	9,069	59.1	58.8	9,744
55.4	55.1	9,086	59.2	58.9	9,762
55.5	55.2	9,104	59.3	59.0	9,780
55.6	55.3	9,122	59.4	59.1	9,798
55.7	55.4	9,140	59.5	59.2	9,815
55.8	55.5	9,158	59.6	59.3	9,833
55.9	55.6	9,175	59.7	59.4	9,851
56.0	55.7	9,193	59.8	59.4	9,869
56.1	55.8	9,211	59.9	59.5	9,887
56.2	55.9	9,229	60.0	59.6	9,904
56.3	56.0	9,246			
56.4	56.1	9,264			
56.5	56.2	9,282			
56.6	56.3	9,300			
56.7	56.4	9,318			
56.8	56.5	9,335			
56.9	56.6	9,353			

APPENDIX B

**EVALUATION OF THE MATURITY METHOD FOR
PRECAST/PRESTRESSED CONCRETE OPERATIONS**

The data collected at the prestressed plant are presented in this appendix. Chapter 4 is the corresponding chapter that details the objectives, experimental design, test layout, analysis approach, results, and conclusions for the evaluation of the maturity method on a precast prestressed application. In this appendix all the individual strength data, temperature graphs, extra strength maturity relationships, 45°-line graphs showing the estimated strength versus the measured strengths, and pictures of the construction and testing process are presented.



Figure B-1: Mock girder

Table B-1: Laboratory cylinder strength data

Intended Age	Actual Time Tested	Concrete Age (hours)	Compressive Strength (psi)	% Range
11 hr.	8/6/04 2:08 AM	11.9	3,120	8.0
			3,380	
			*	
20 hr.	8/6/04 10:38 AM	20.4	4,490	3.1
			4,570	
			4,430	
34 hr.	8/6/04 11:55 PM	33.7	4,910	4.8
			5,150	
			4,930	
42 hr.	8/7/04 8:25 AM	42.2	5,080	3.2
			4,970	
			4,920	
66 hr.	8/8/04 8:20 AM	66.1	5,330	2.1
			5,390	
			5,280	
4 Day	8/9/04 1:33 PM	95.3	5,760	4.4
			5,580	
			5,830	
7 Day	8/12/04 2:26 PM	168.2	6,170	3.1
			5,980	
			6,080	
28 Day	9/2/04 2:10 PM	671.9	6,850	5.4
			7,230	
			6,920	

* Indicates cylinders removed due to compression machine failure

Table B-2: Lime-saturated water-tank cylinder strength data

Intended Age	Actual Time Tested	Concrete Age (hours)	Compressive Strength (psi)	% Range
8 hr.	8/5/04 10:19 PM	8.1	*	0.0
			*	
			3,600	
12 hr.	8/6/04 2:28 AM	12.2	4,370	1.4
			4,430	
			4,390	
18 hr.	8/6/04 8:38 AM	18.4	4,600	4.5
			4,810	
			4,670	
24 hr.	8/6/04 2:29 PM	24.2	4,890	5.5
			5,170	
			5,160	
48 hr.	8/7/04 2:45 PM	48.5	5,350	0.8
			5,310	
			-	
4 Day	8/9/04 2:18 PM	96.0	6,170	0.0
			6,170	
			-	
7 Day	8/12/04 2:15 PM	168.0	6,080	0.8
			6,130	
			-	
28 Day	9/2/04 1:35 PM	671.3	7,000	1.4
			7,100	
			-	

* Indicates cylinders removed due to compression machine failure

- Indicates no cylinders data due to not enough concrete produced

Table B-3: Damp-sand-pit cylinder strength data

Intended Age	Actual Time Tested	Concrete Age (hours)	Compressive Strength (psi)	% Range
8 hr.	8/5/04 10:19 PM	8.1	*	0.0
			*	
			3,600	
12 hr.	8/6/04 2:28 AM	12.2	4,370	1.4
			4,430	
			4,390	
18 hr.	8/6/04 8:38 AM	18.4	4,600	4.5
			4,810	
			4,670	
24 hr.	8/6/04 2:39 PM	24.4	5,090	6.8
			4,760	
			5,100	
48 hr.	8/7/04 2:45 PM	48.5	5,400	4.4
			5,170	
			-	
4 Day	8/9/04 2:18 PM	96.0	5,800	1.7
			5,900	
			-	
7 Day	8/12/04 2:50 PM	168.6	6,260	2.3
			6,120	
			-	
28 Day	9/2/04 1:45 PM	671.5	7,090	4.1
			7,390	
			-	

* Indicates cylinders removed due to compression machine failure

- Indicates no cylinders data due to not enough concrete produced

Table B-4: Side pullout of mock girder strength data

Intended Age	Actual Time Tested	Concrete Age (hours)	Pullout Load (kN)	Compressive Strength (psi)	% Range
12 hr	8/6/04 2:28 AM	12.2	26.4	3,920	33.7
			29.9	4,550	
			27.4	4,100	
			24.8	3,630	
			22.0	3,200	
			27.3	4,080	
			27.5	4,120	
18 hr.	8/6/04 8:40 AM	18.4	29.3	4,440	35.1
			28.3	4,260	
			24.7	*	
			37.3	5,880	
			30.1	4,590	
			37.3	5,880	
			34.3	5,350	
24 hr.	8/6/04 2:20 PM	24.1	27.7	4,150	27.9
			29.3	4,440	
			32.5	5,020	
			38.0	6,000	
			29.8	4,530	
			33.7	5,240	
			35.6	5,580	
48 hr.	8/7/04 3:27 PM	49.2	36.0	5,650	28.0
			31.2	4,790	
			34.3	5,350	
			39.6	6,280	
			33.2	5,150	
			38.7	6,120	
			-	-	
7 day	8/12/04 1:25 PM	167.2	30.7	4,700	32.6
			38.2	6,040	
			33.0	5,110	
			39.0	6,170	
			39.0	6,170	
			46.0	7,420	
			36.3	5,700	
28 day	9/2/04 1:25 PM	671.2	34.7	5,420	25.9
			37.4	5,900	
			37.1	5,840	
			36.1	5,670	
			43.5	6,970	
			40.0	6,350	
			42.8	6,850	
28 day	9/2/04 1:25 PM	671.2	42.9	6,860	25.9
			46.9	7,570	
			44.3	7,110	
			37.1	5,840	
			32.6	*	
			39.2	6,210	

* Indicates pullout test removed due to outliers

- Indicates no pullout data due to failure to conduct test on mock girder

Table B-5: Top pullout of mock girder strength data

Intended Age	Actual Time Tested	Concrete Age (hours)	Pullout Load (kN)	Compressive Strength (psi)	% Range
12 hr	8/6/04 2:28 AM	12.2	29.7	4,520	27.3
			-	-	
			27.2	4,060	
			34.0	5,300	
			28.3	4,260	
18 hr.	8/6/04 8:40 AM	18.4	31.2	4,790	19.3
			-	-	
			32.9	5,100	
			34.9	5,460	
			29.6	4,500	
24 hr.	8/6/04 2:20 PM	24.1	38.4	6,070	29.8
			29.2	4,430	
			34.2	5,330	
			37.0	5,830	
			37.0	5,830	
48 hr.	8/7/04 3:27 PM	49.2	38.9	6,160	23.1
			35.3	5,530	
			34.8	5,440	
			41.3	6,580	
			33.7	5,240	
7 day	8/12/04 1:25 PM	167.2	40.9	6,510	10.0
			40.9	6,510	
			41.9	6,690	
			42.2	6,740	
			44.7	7,180	
28 day	9/2/04 1:25 PM	671.2	49.1	7,970	9.3
			53.2	8,700	
			51.9	8,460	
			48.9	7,930	
			-	-	

* Indicates pullout test removed due to outliers

- Indicates no pullout data due to failure to conduct test on mock girder

Table B-6: Pullout cube strength data

Intended Age	Actual Time Tested	Concrete Age (hours)	Pullout Load (kN)	Compressive Strength (psi)	% Range
18 hr.	8/6/04 9:15 AM	19.0	35.8	5,620	9.6
			33.2	5,150	
			34.1	5,310	
			33.0	5,110	
			33.5	5,210	
			35.3	5,530	
			34.5	5,390	
			-	-	
48 hr.	8/7/04 3:55 PM	49.7	36.8	5,790	11.3
			35.1	5,490	
			38.4	6,070	
			38.2	6,040	
			34.7	5,420	
			45.1	-	
			37.4	5,900	
			35.1	5,490	
7 Day	8/12/04 1:55 PM	167.7	45.6	7,340	16.6
			45.6	7,340	
			39.5	6,260	
			44.6	7,170	
			46.1	7,430	
			36.3	-	
			41.2	6,560	
			44.6	7,170	

- Indicates no pullout data due to failure to conduct test on pullout cube

Plan View
AASHTO
Type IV - 19'

Scale
 ← 2' →

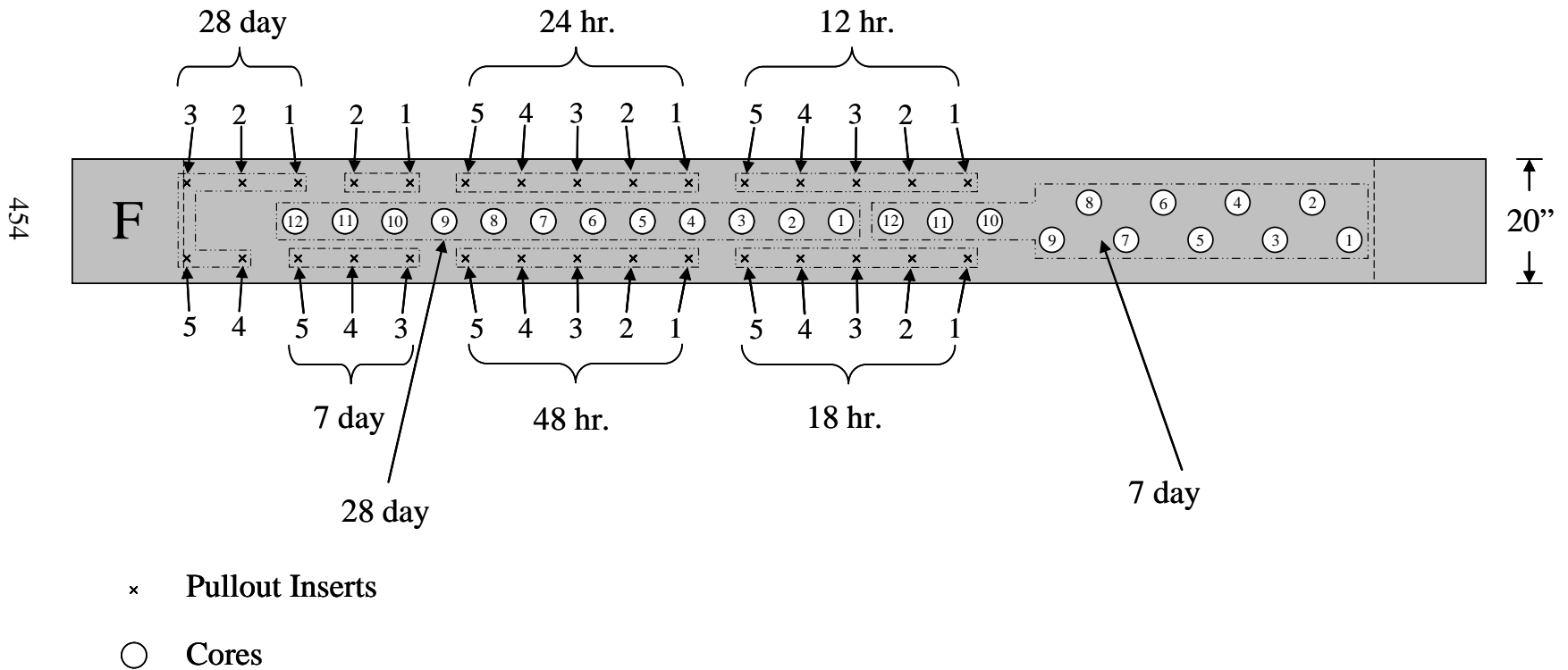

Figure B-2: Top of mock girder cores and pullout inserts layout and numbering

Table B-7: ASTM C 42 core strength data

Intended Age	Actual Time Tested	Concrete Age (hours)	Compressive Strength (psi)	% Range
7 day	8/12/04 2:42 PM	168.5	5,530	4.5
			*	
			5,320	
			5,290	
			-	
28 day	9/2/04 2:50 PM	672.6	5,910	5.9
			6,100	
			6,270	
			6,150	
			6,020	

* Indicates cores removed due to outliers

- Indicates no core data due to failure to remove from mock girder

Table B-8: ASTM C42 core dimensions

Intended Age	Core Number	Diameter (in.)				Length (in.)		L/D
		1	2	Avg.	% Diff.	Before Capping	After Capping	
7 day	1	-	-	-	-	-	-	-
	6	3.99	3.98	3.99	0.25%	8.1	8.3	2.03
	7	4.01	4.00	4.01	0.25%	8.1	8.2	2.02
	10	4.00	3.99	4.00	0.25%	8.0	8.2	2.00
	11	3.98	3.99	3.99	0.25%	8.0	8.2	2.01
28 day	1	3.98	3.97	3.98	0.25%	8.0	8.3	2.01
	4	3.98	3.98	3.98	0.00%	8.0	8.3	2.01
	5	3.98	3.99	3.99	0.25%	8.0	8.3	2.01
	8	3.98	3.98	3.98	0.00%	8.0	8.2	2.01
	9	3.99	4.00	4.00	0.25%	8.0	8.3	2.00

- Indicates no core data due to failure to remove from mock girder

Table B-9: AASHTO T 24 core strength data

Intended Age	Actual Time Tested	Concrete Age (hours)	Compressive Strength (psi)	% Range
7 day	8/12/04 2:56 PM	168.7	*	7.4
			5,130	
			4,910	
			5,290	
			-	
28 day	9/2/04 2:30 PM	672.2	5,860	4.9
			5,770	
			5,940	
			6,060	
			-	

* Indicates cores removed due to outliers

- Indicates no core data due to failure to remove from mock girder

Table B-10: AASHTO T 24 core dimensions

Intended Age	Core Number	Diameter (in.)				Length (in.)		L/D
		1	2	Avg.	% Diff.	Before Capping	After Capping	
7 day	4	4.00	3.99	4.00	0.25%	8.1	8.4	2.03
	5	3.99	3.98	3.99	0.25%	8.1	8.2	2.03
	8	4.00	3.99	4.00	0.25%	8.1	8.2	2.03
	9	4.00	3.99	4.00	0.25%	8.0	8.3	2.00
	12	-	-	-	-	-	-	-
28 day	2	3.98	3.98	3.98	0.00%	8.0	8.2	2.01
	3	3.98	3.98	3.98	0.00%	8.0	8.3	2.01
	6	3.97	3.98	3.98	0.25%	8.0	8.2	2.01
	7	3.98	3.99	3.99	0.25%	8.0	8.2	2.01
	12	-	-	-	-	-	-	-

- Indicates no core data due to failure to remove from mock girder

All temperature data for the prestressed project are given below. Figure B-3 shows the ambient temperatures for the entire project. The remaining temperatures graphs only show the first seven days of data. The remaining temperatures were not shown because the temperatures of the specimens and mock girder followed the ambient temperatures fairly closely. The first seven days were graphed to show the temperature associated with the hydration of the concrete.

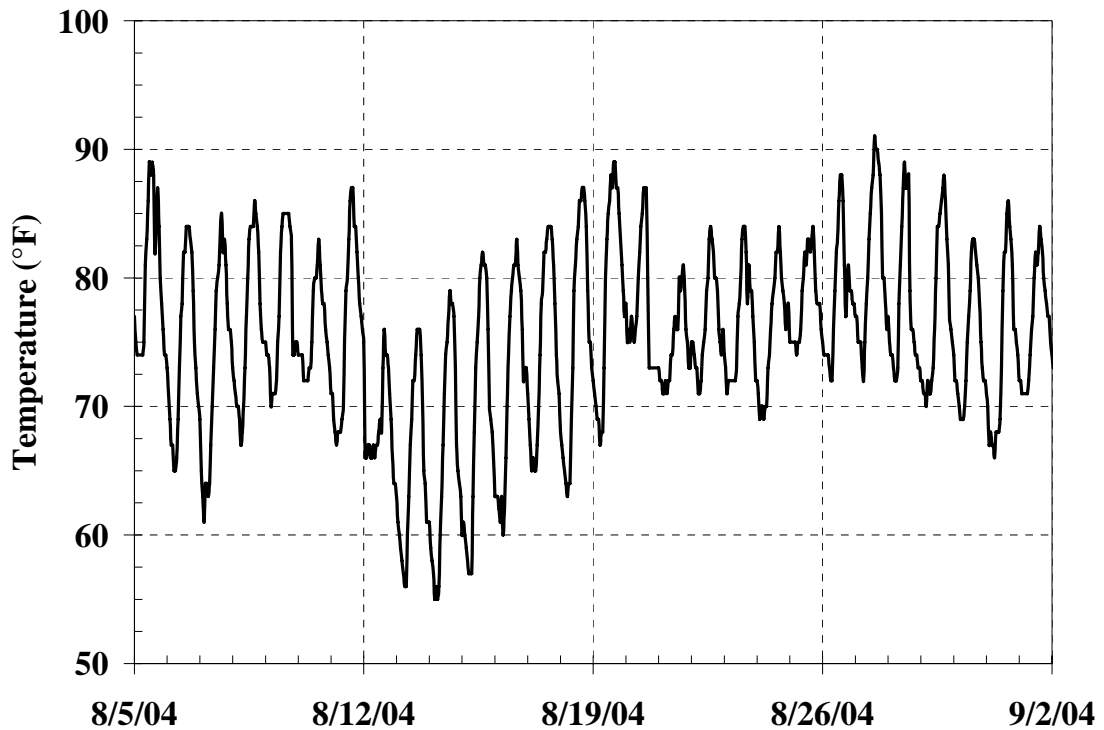

Figure B-3: Ambient air temperatures of the prestressed plant project

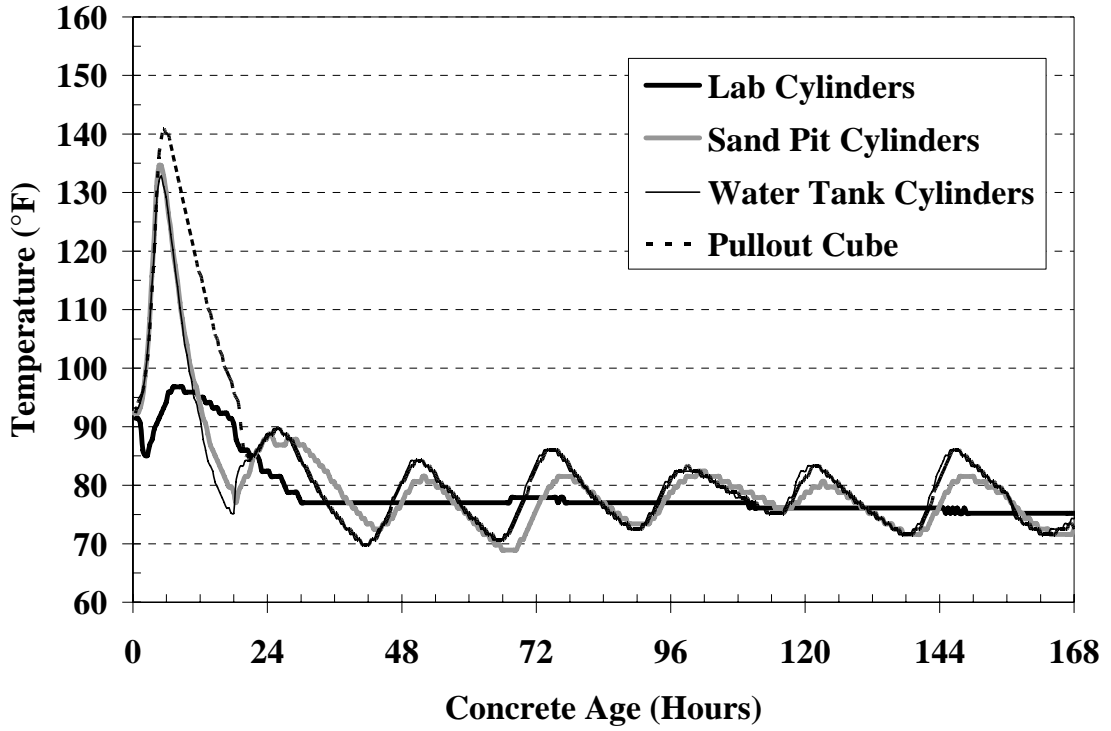

Figure B-4: Molded cylinder temperature history

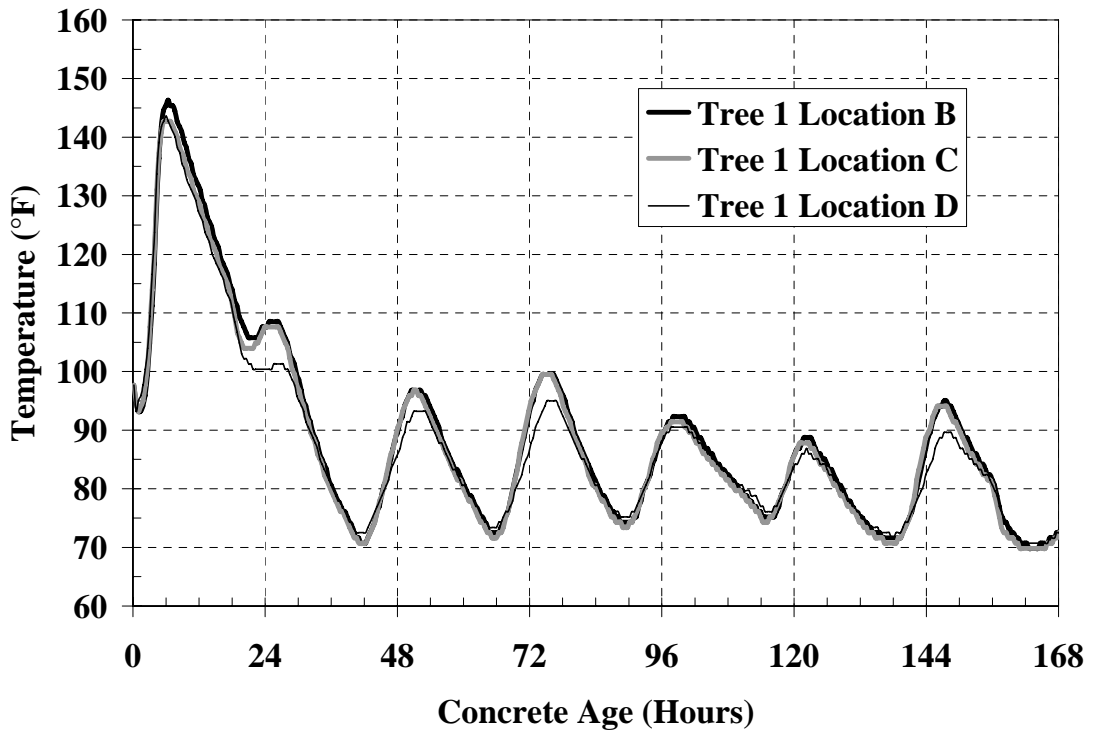

Figure B-5: Girder temperatures Tree 1 Location B, C, and D

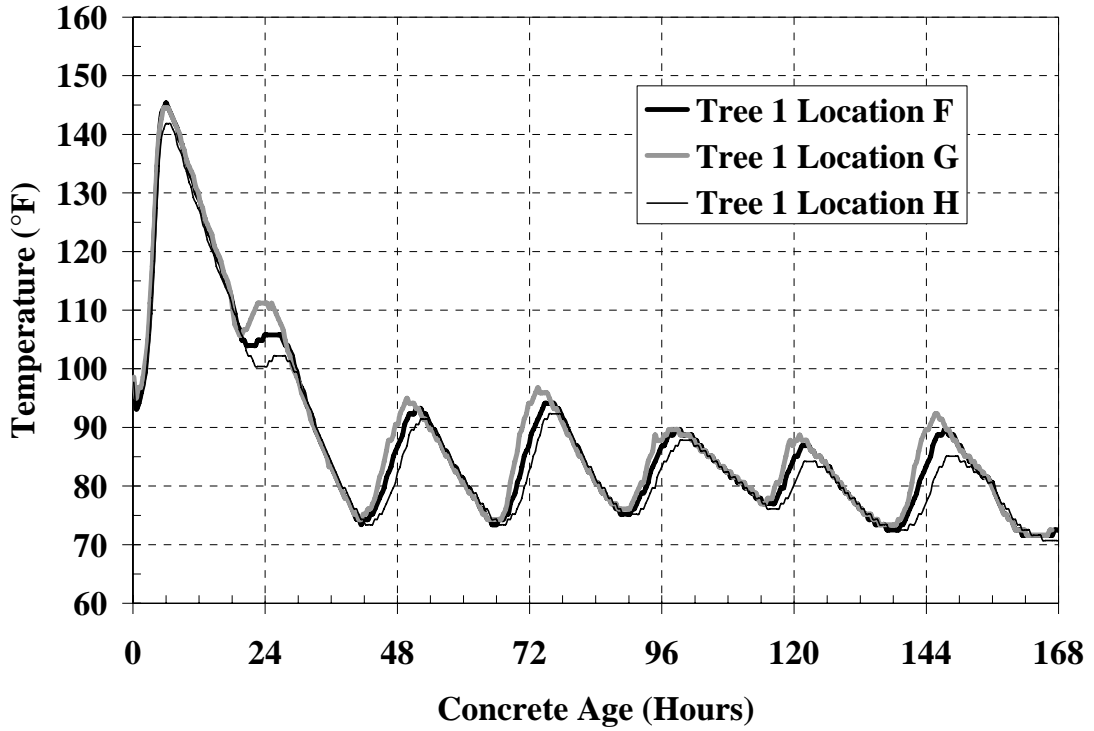

Figure B-6: Girder temperatures Tree 1 Location F, G, and H

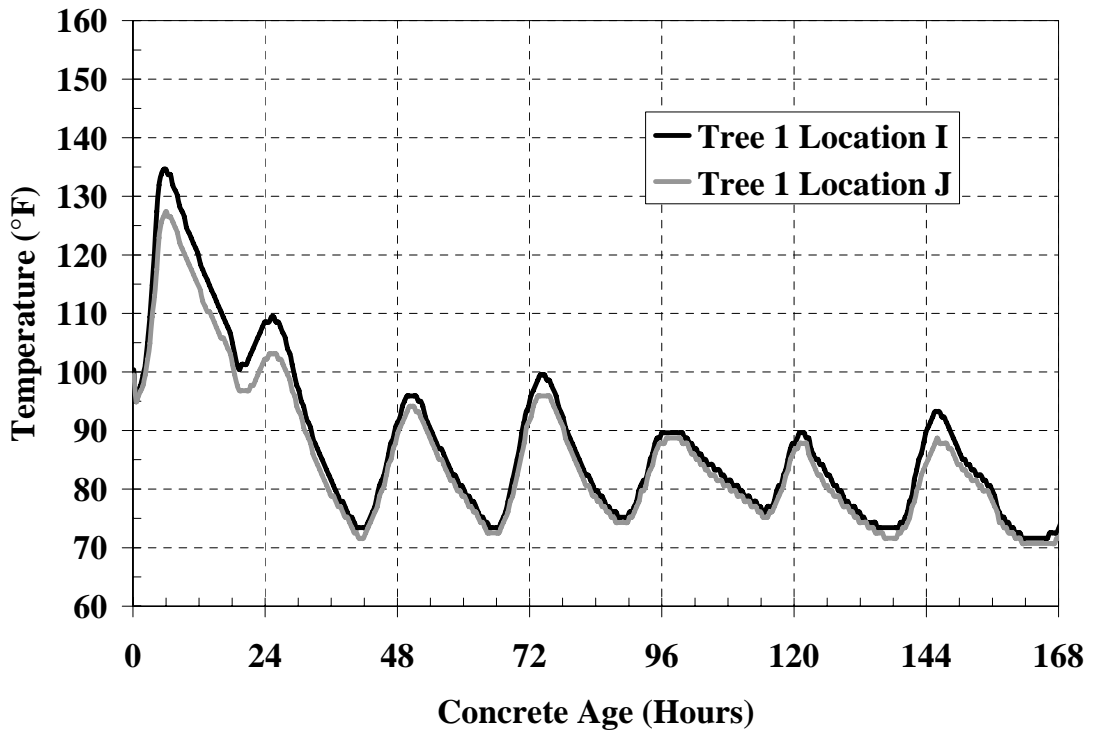

Figure B-7: Girder temperatures Tree 1 Location I and J

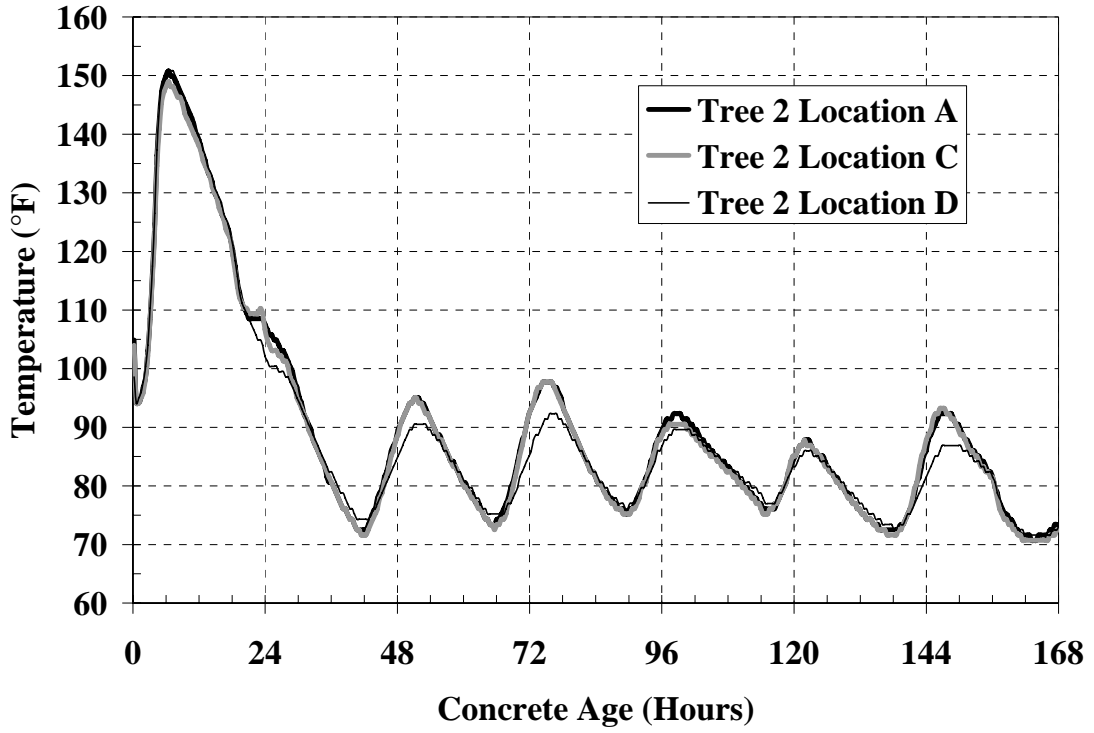

Figure B-8: Girder temperatures Tree 2 Location A, C, and D

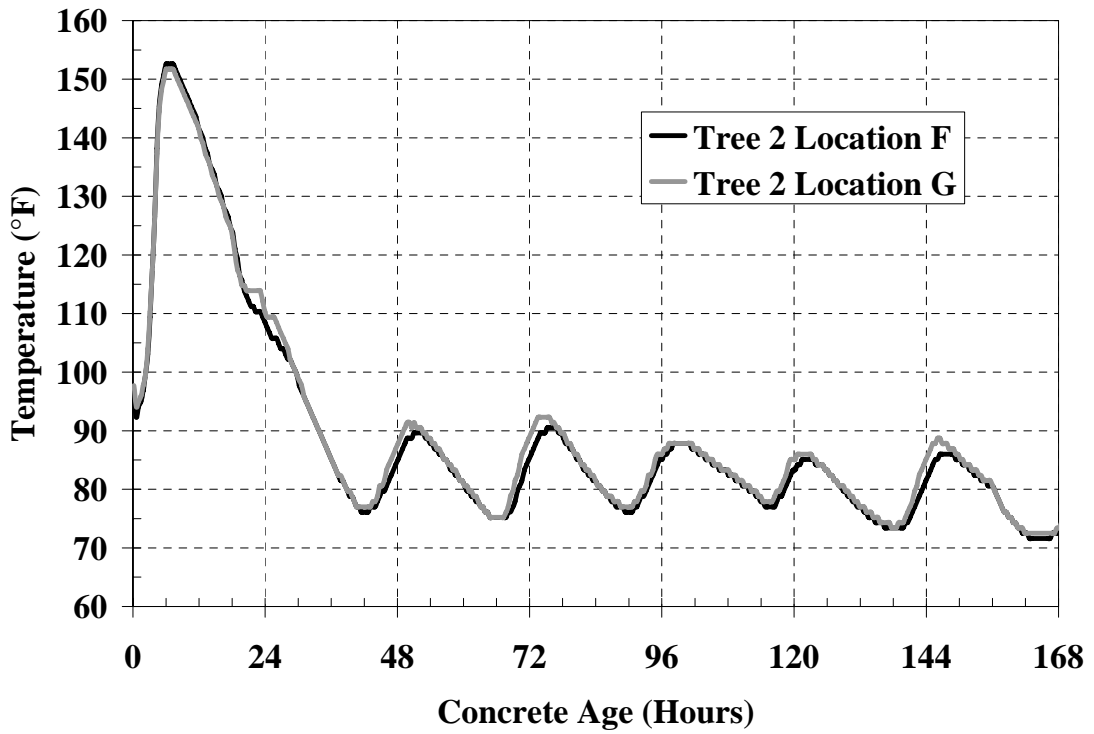

Figure B-9: Girder temperatures Tree 2 Location F and G

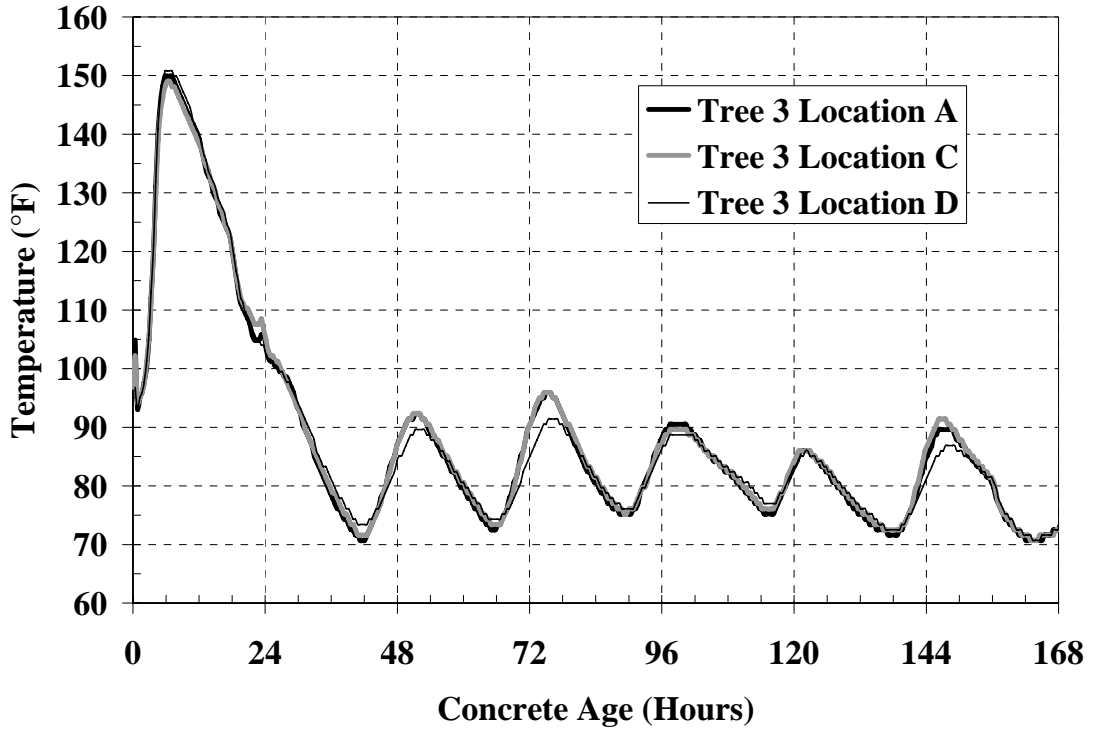

Figure B-10: Girder temperatures Tree 3 Location A, C, and D

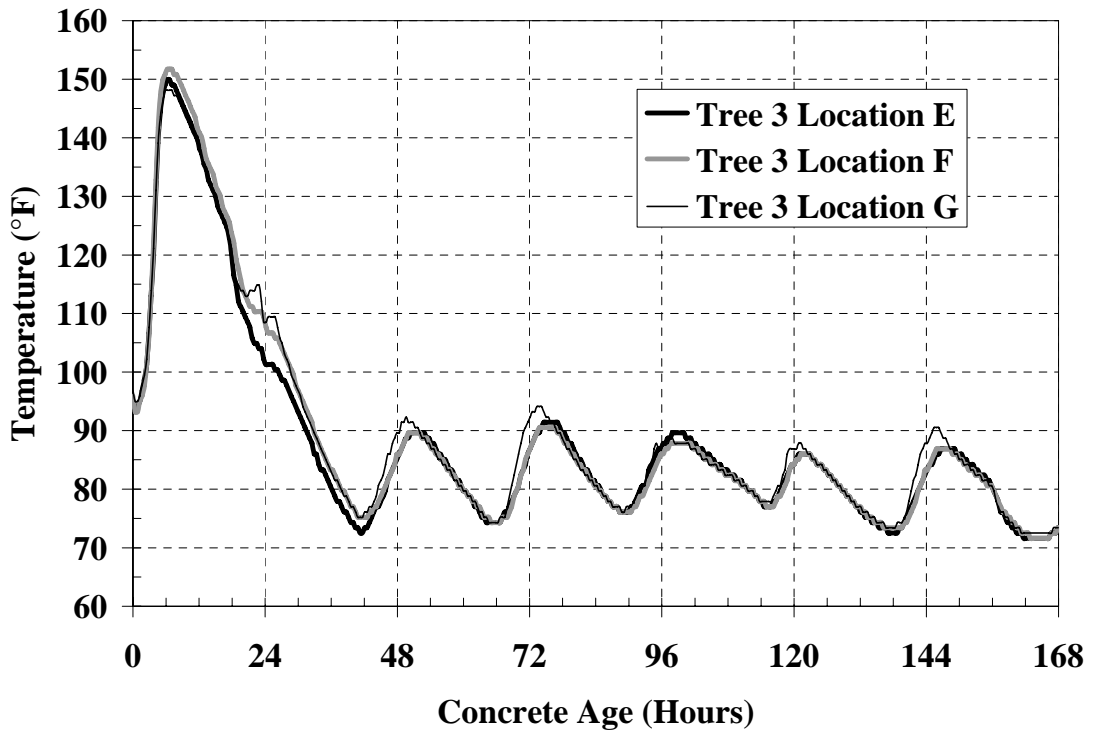

Figure B-11: Girder temperatures Tree 3 Location E, F, and G

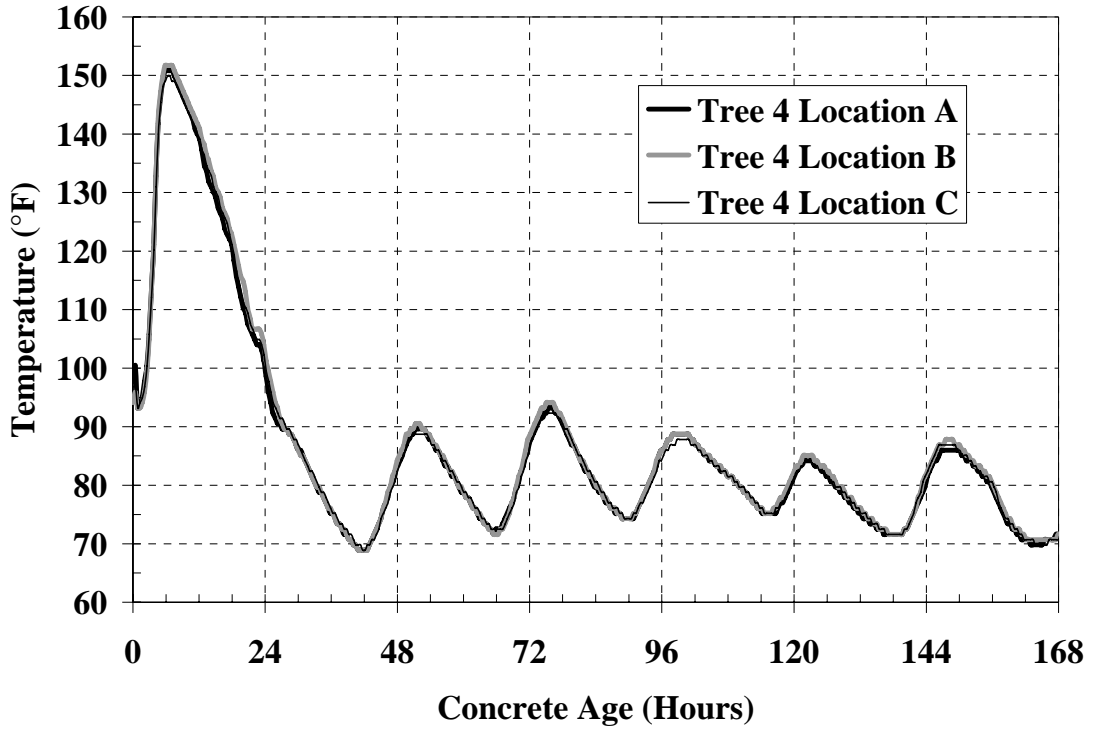

Figure B-12: Girder temperatures Tree 4 Location A, B, and C

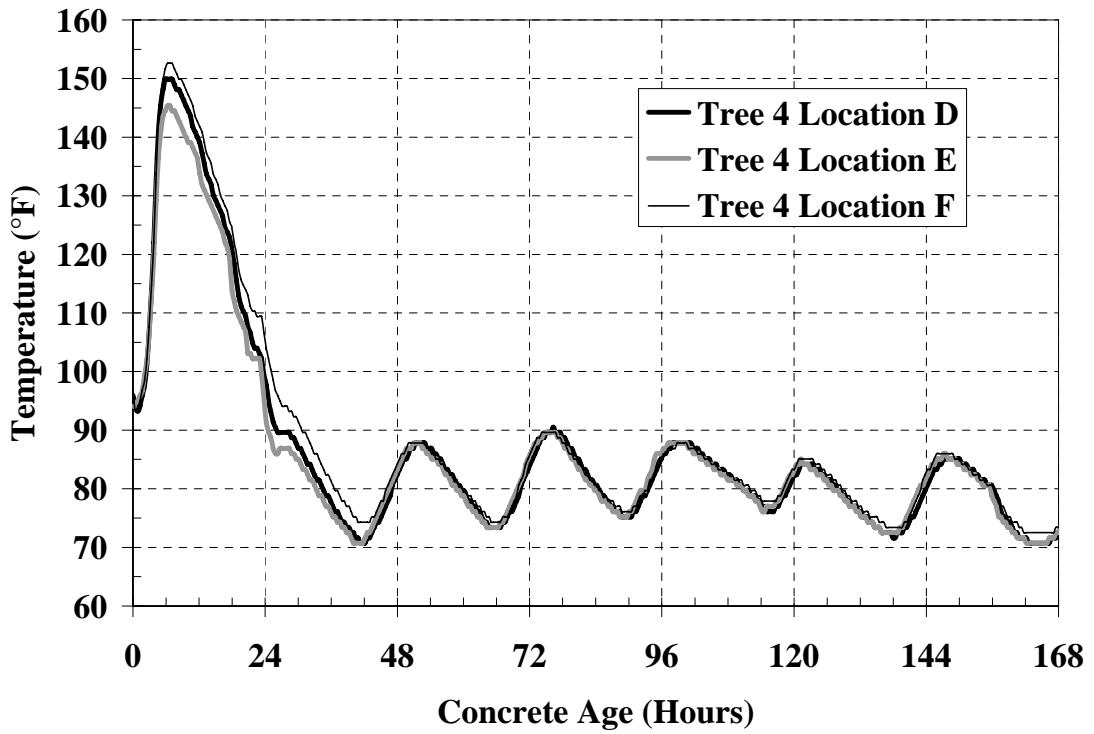

Figure B-13: Girder temperatures Tree 4 Location D, E, and F

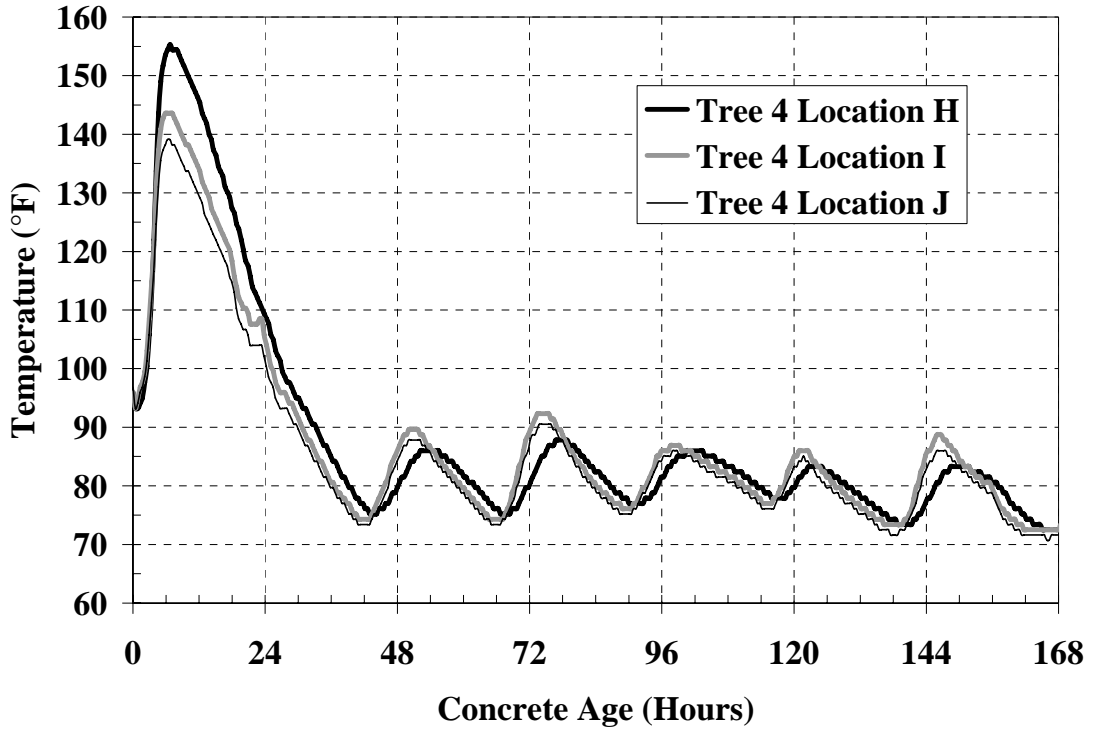

Figure B-14: Girder temperatures Tree 4 Location H, I, and J

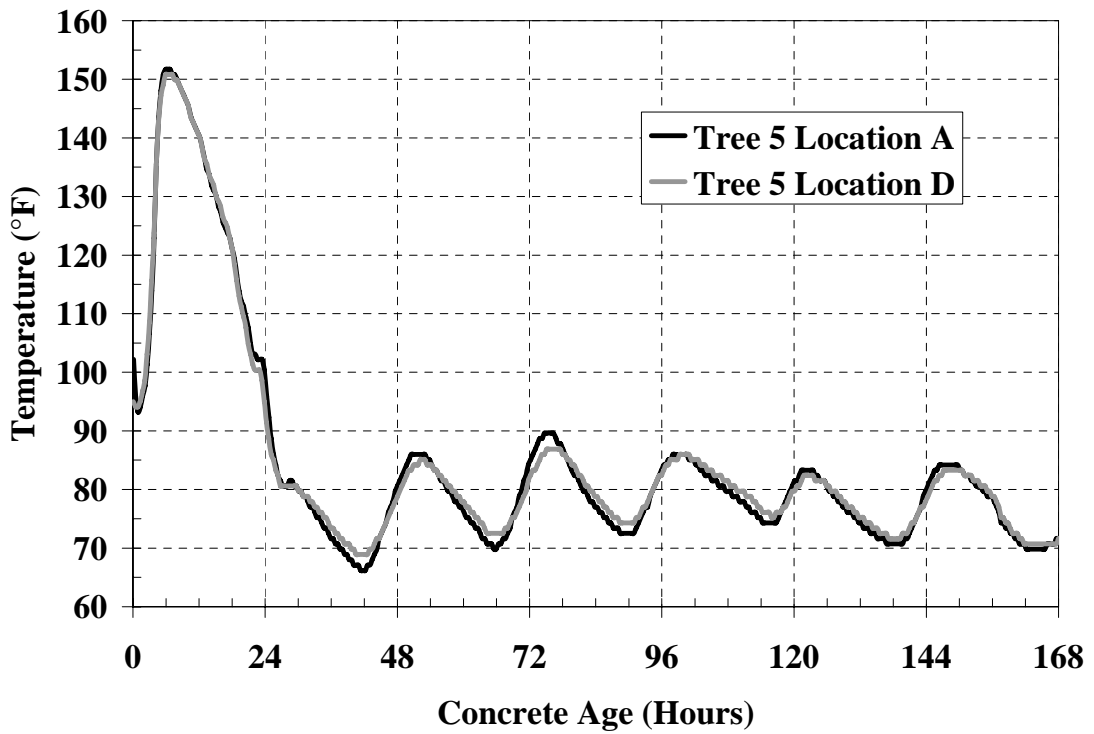

Figure B-15: Girder temperatures Tree 5 Location A and D

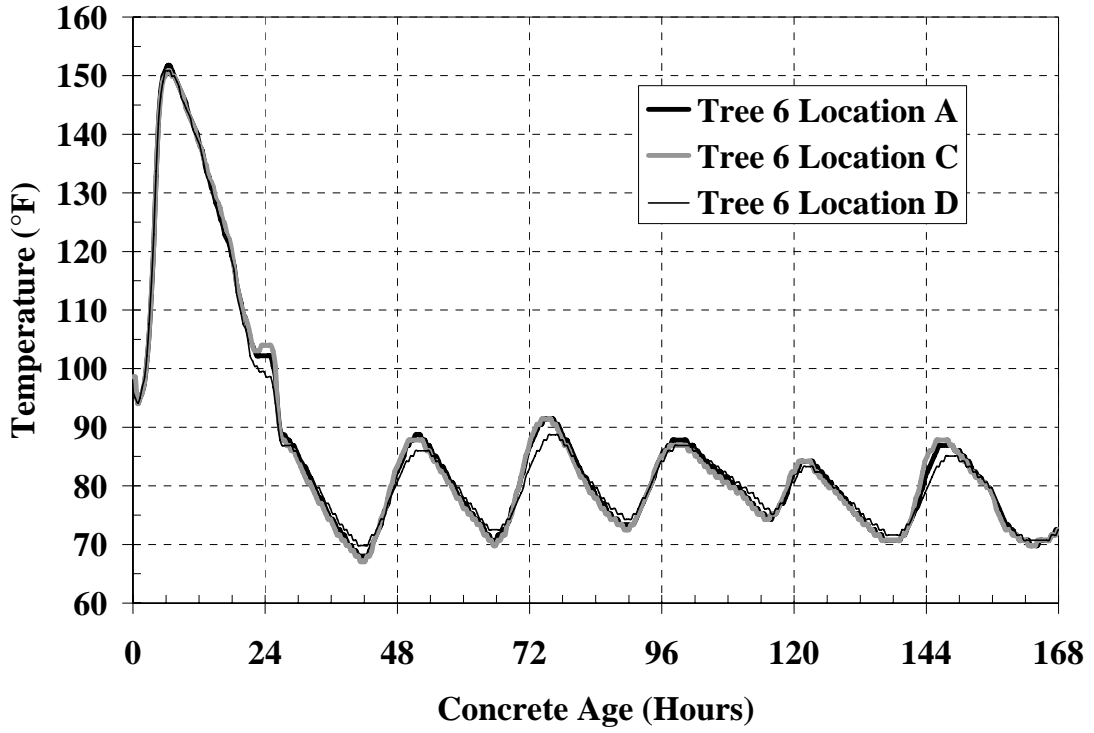

Figure B-16: Girder temperatures Tree 6 Location A, C, and D

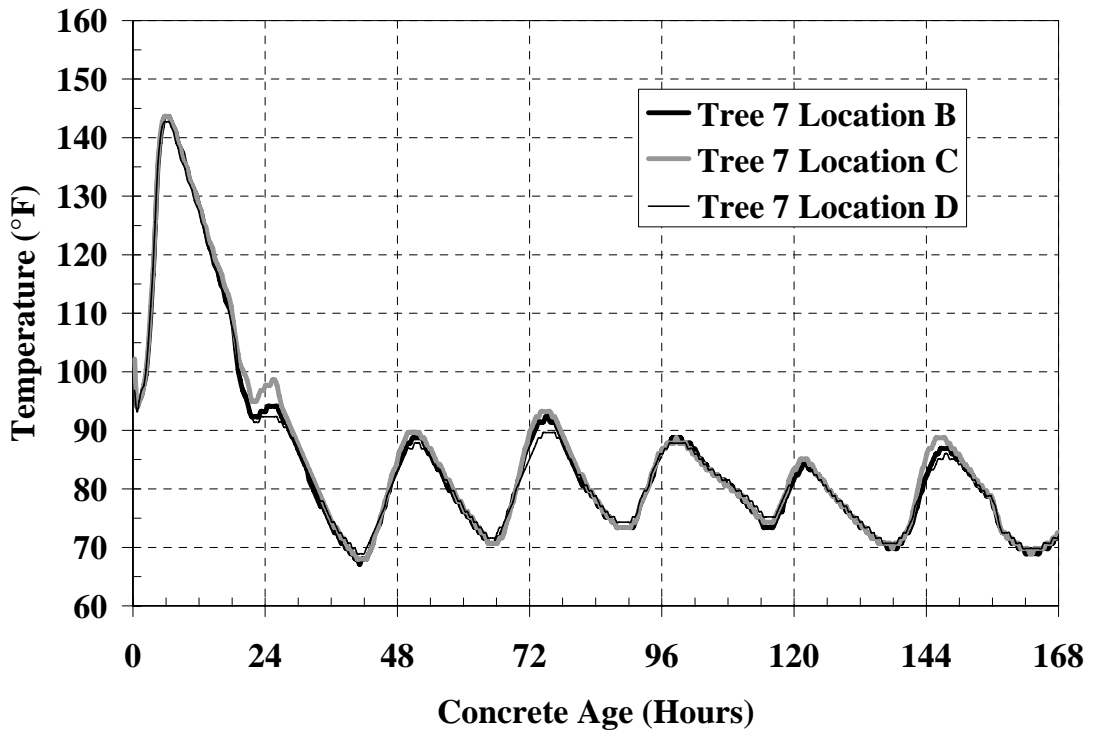

Figure B-17: Girder temperatures Tree 7 Location B, C, and D

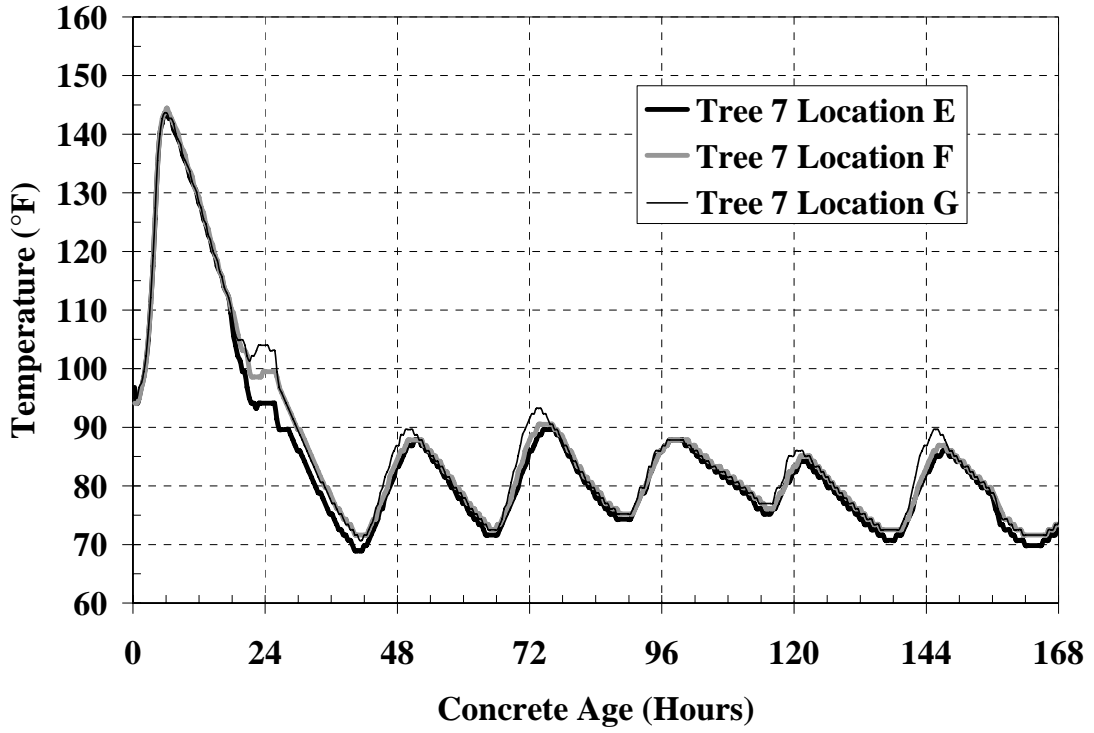

Figure B-18: Girder temperatures Tree 7 Location E, F, and G

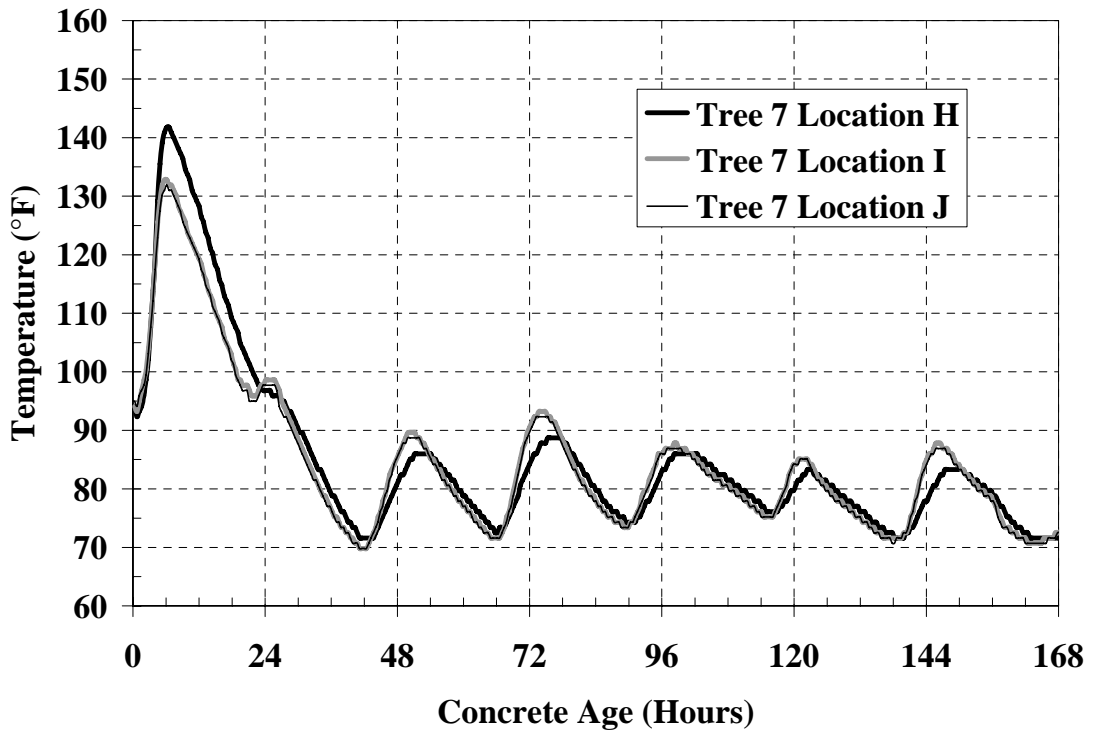

Figure B-19: Girder temperatures Tree 7 Location B, C, and D

The following tables and figures give the best-fit exponential function values for the S-M relationship, the *water-tank* and *sand-pit* S-M relationships for the molded cylinders and in-place testing, and the estimated cylinder and in-place strengths from the all maturity functions. Nurse-Saul maturity function is abbreviated as NSM function, and the Arrhenius maturity function is abbreviated as AM function.

Table B-11: Strength-maturity relationship exponential function values

	<i>Exponential Value</i>	<i>Concrete Age</i>	<i>Nurse-Saul Function</i>		<i>Arrhenius Function</i>	
			$T_0 = 0\text{ }^\circ\text{C}$	$T_0 = -10\text{ }^\circ\text{C}$	E = 33,500 J/mol	E = 40,000 J/mol
<i>Lab</i>	S_u (psi)	7,681	7,610	7,625	7,577	7,562
	β	0.4909	0.5621	0.5424	0.5893	0.6110
	τ	7.2936	259.9125	330.8115	12.8073	14.3421
	R^2	0.99	0.99	0.99	0.99	0.99
<i>Damp-Sand Pit</i>	S_u (psi)	7,823	7,521	7,572	7,367	7,306
	β	0.4101	0.5637	0.5254	0.6849	0.7629
	τ	3.7098	191.3413	225.2031	12.5429	16.2263
	R^2	0.99	0.99	0.99	0.99	0.99
<i>Lime-Saturated Water Tank</i>	S_u (psi)	9,712	8,571	8,765	8,193	8,025
	β	0.2504	0.3830	0.3487	0.4756	0.5387
	τ	5.8848	203.8940	253.0816	12.1422	15.2133
	R^2	0.99	0.99	0.99	0.99	0.99

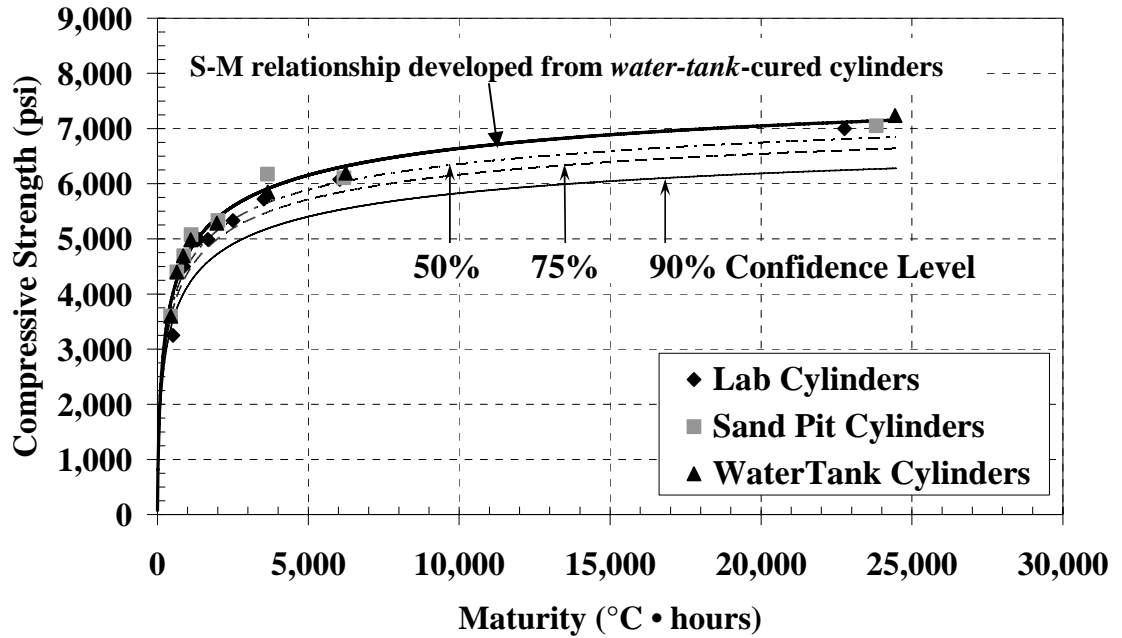

Figure B-20: *Water-tank* S-M relationship with confidence levels ($T_0 = -10\text{ }^\circ\text{C}$)

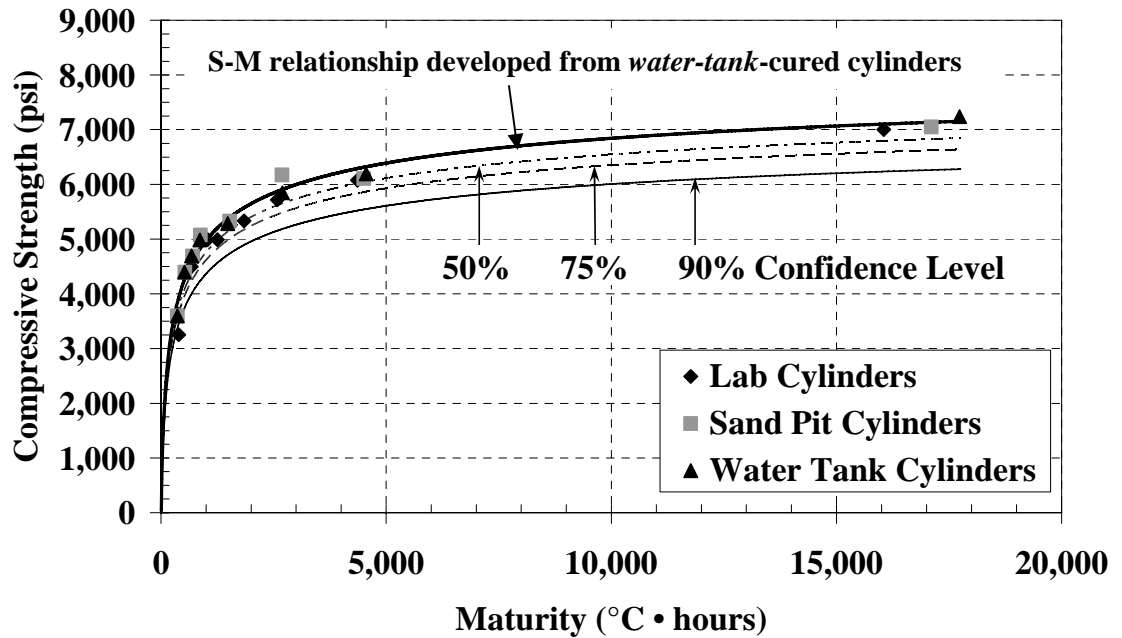

Figure B-21: *Water-tank* S-M relationship with confidence levels ($T_0 = 0\text{ }^\circ\text{C}$)

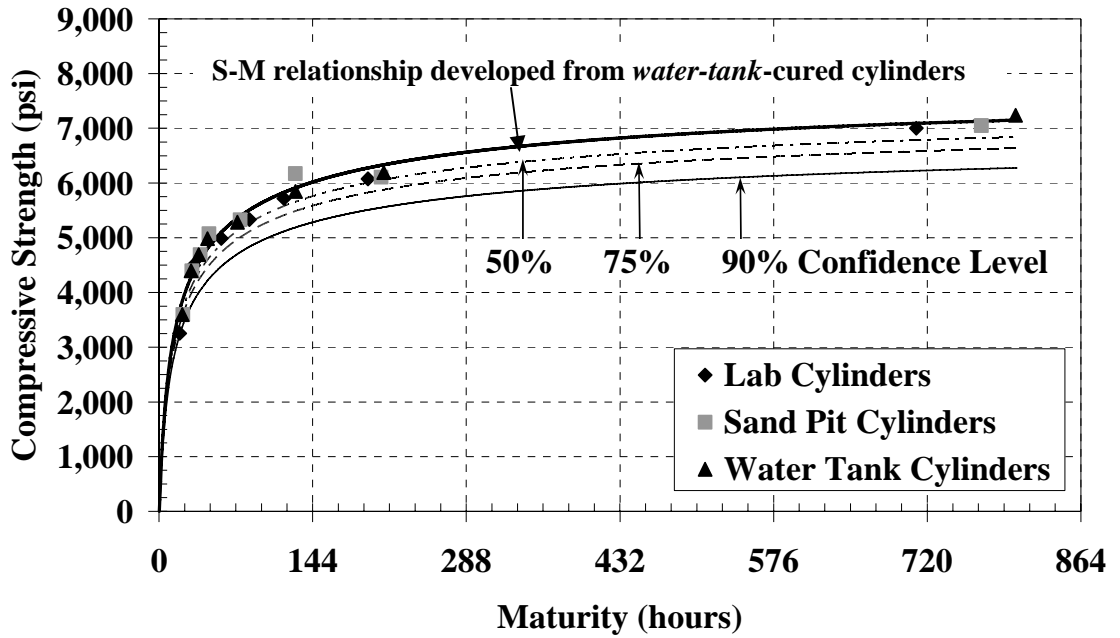

Figure B-22: Water-tank S-M relationship with confidence levels ($E = 33.5$ kJ/mol)

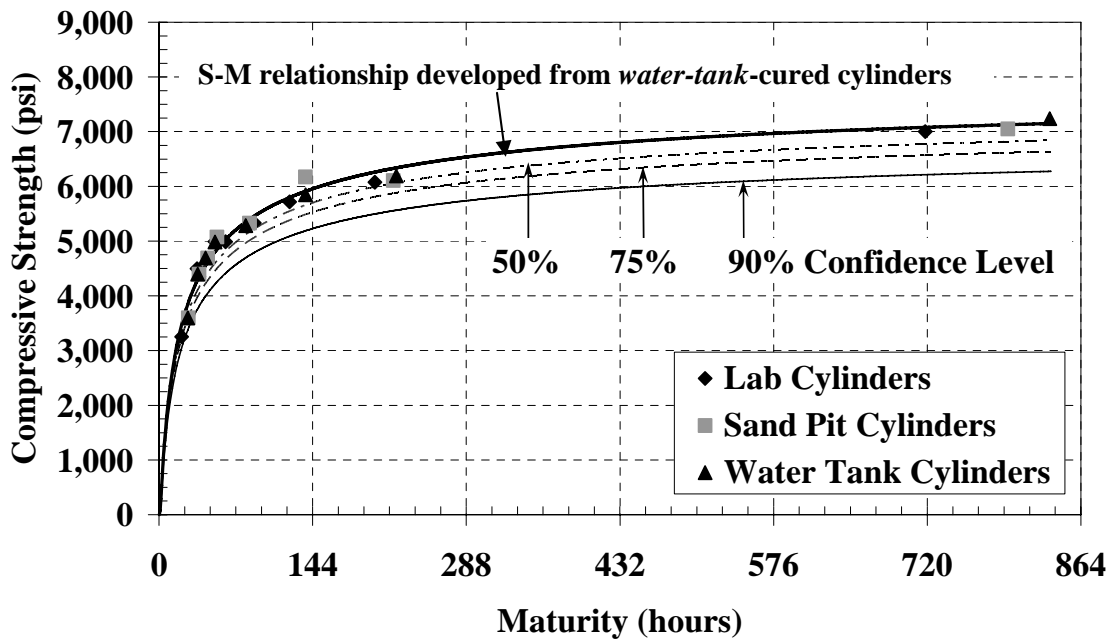

Figure B-23: Water-tank S-M relationship with confidence levels ($E = 40$ kJ/mol)

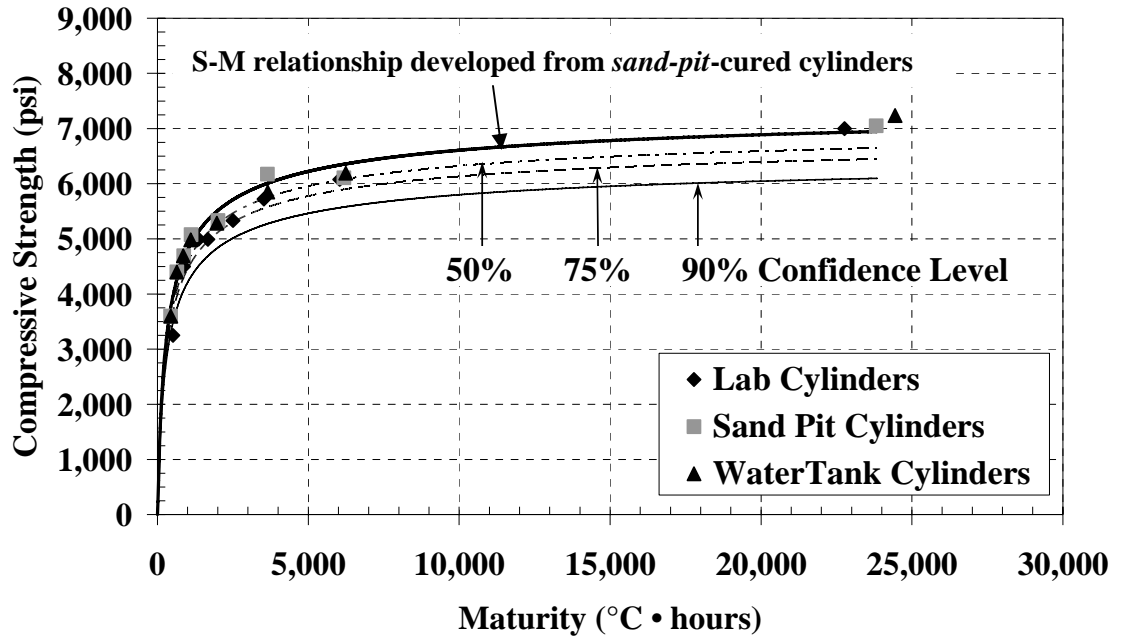

Figure B-24: *Sand-pit* S-M relationship with confidence levels ($T_0 = -10\text{ }^\circ\text{C}$)

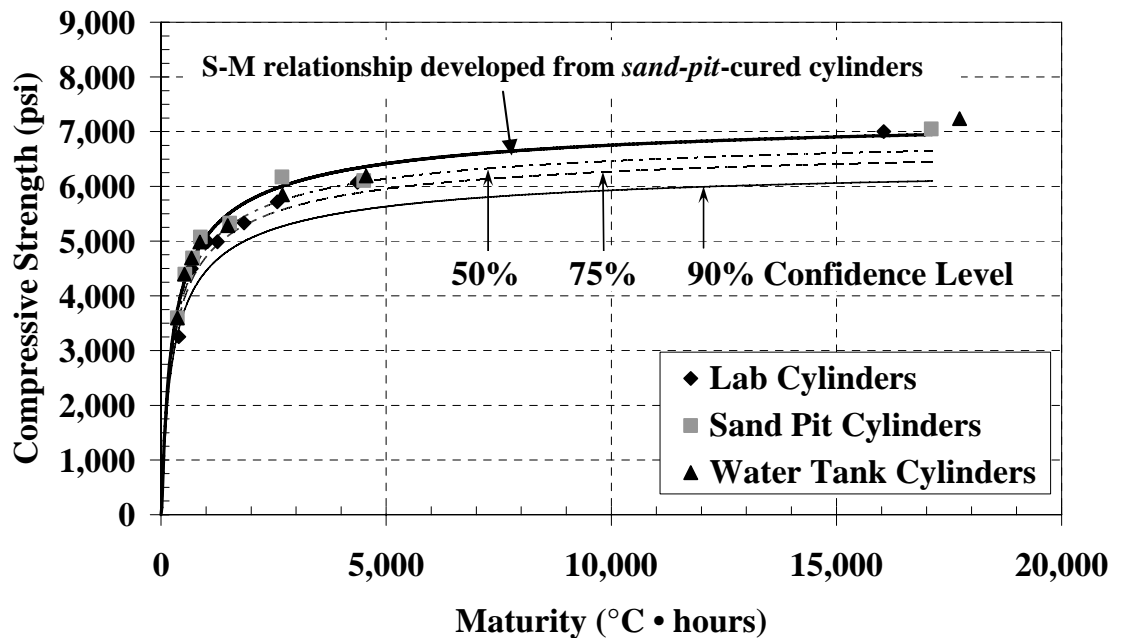

Figure B-25: *Sand-pit* S-M relationship with confidence levels ($T_0 = 0\text{ }^\circ\text{C}$)

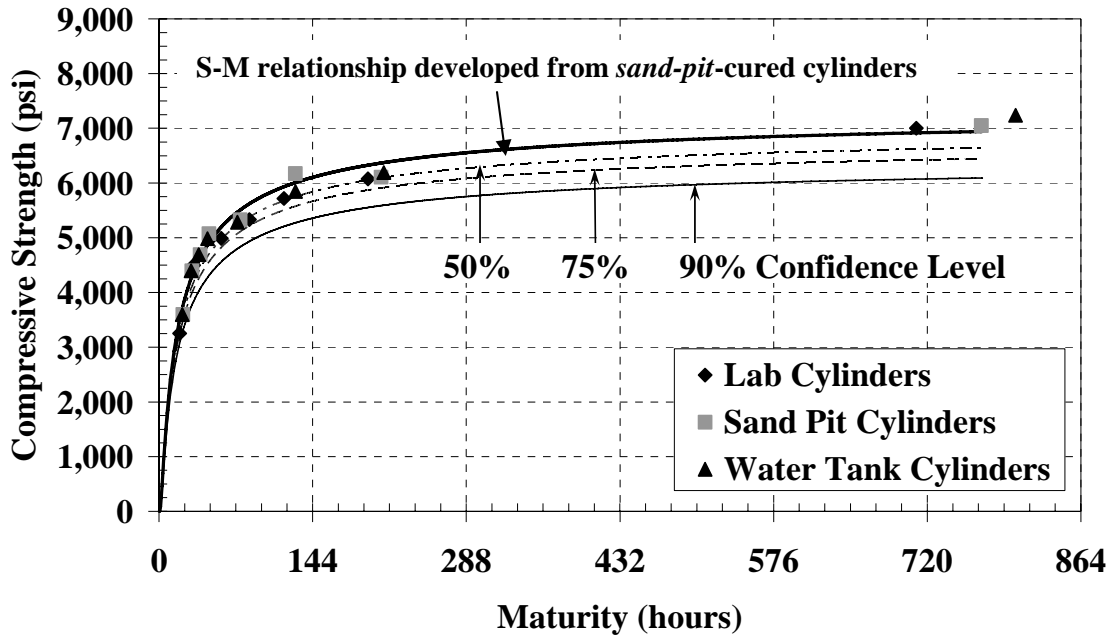

Figure B-26: *Sand-pit* S-M relationship with confidence levels (E = 33.5 kJ/mol)

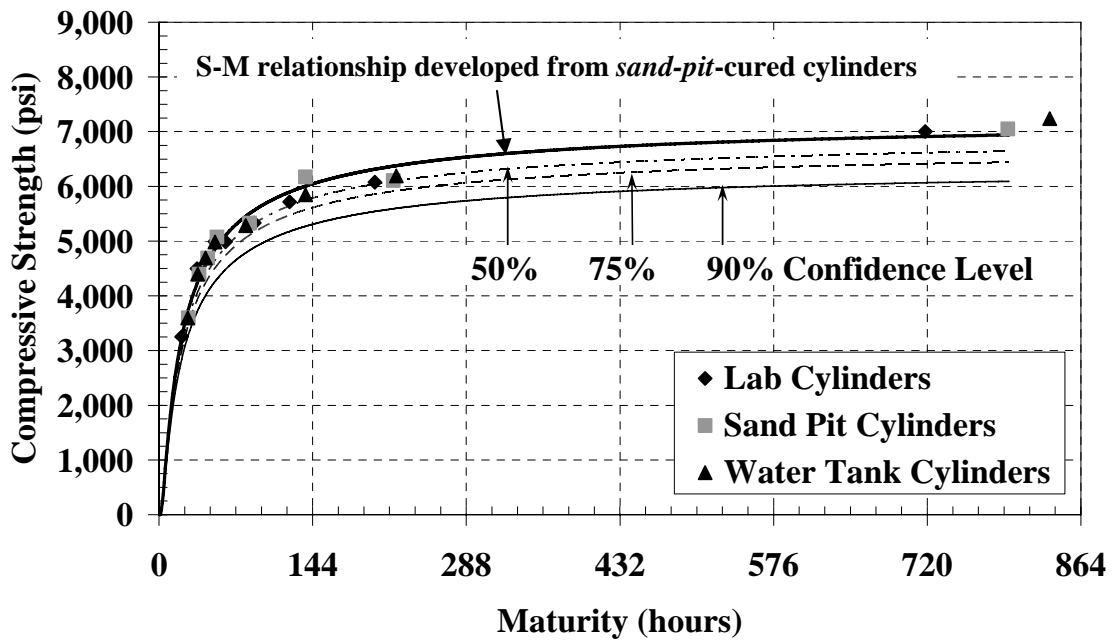

Figure B-27: *Sand pit* S-M relationship with confidence levels (E = 40 kJ/mol)

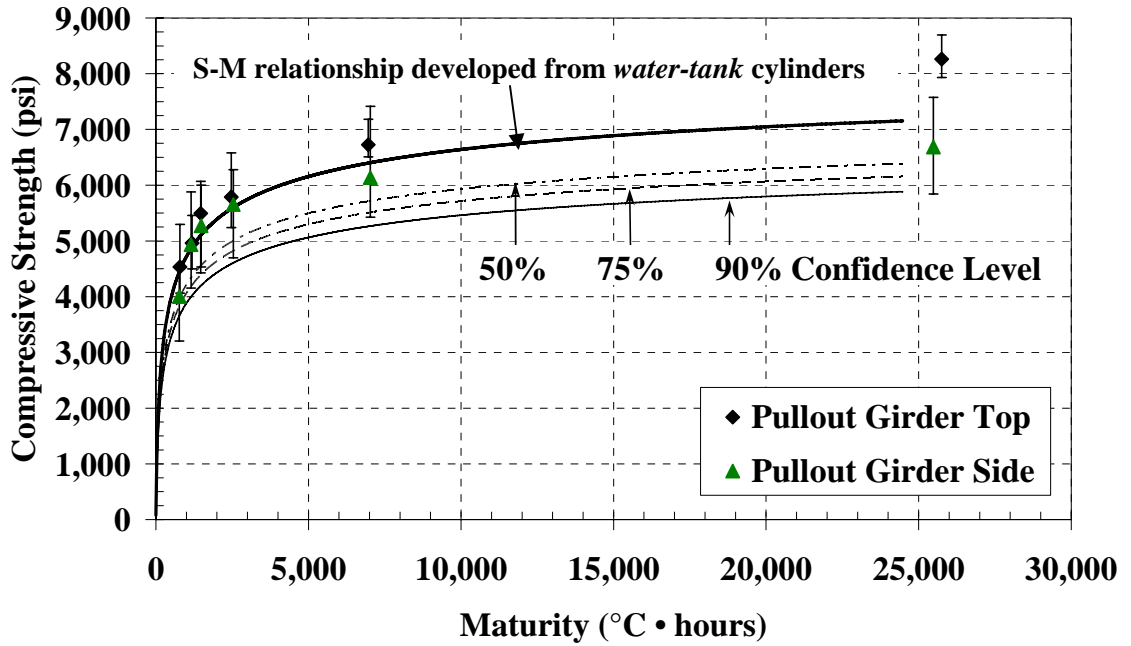

Figure B-28: Pullout test with *water-tank* S-M relationship and confidence levels ($T_o = -10^{\circ}\text{C}$)

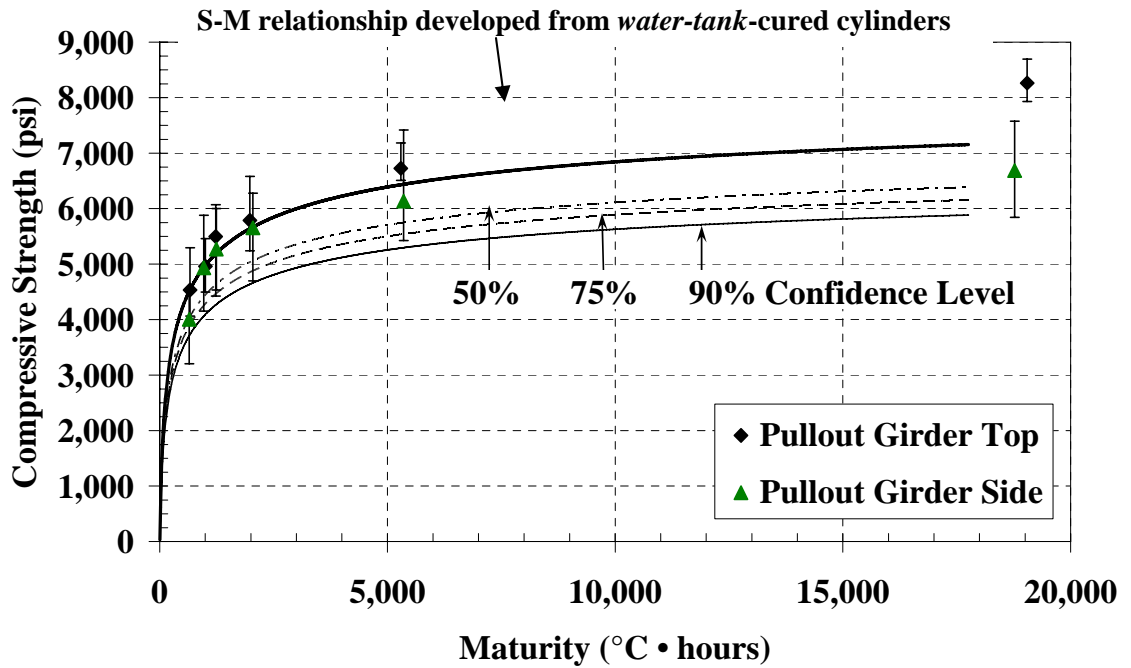

Figure B-29: Pullout test with *water-tank* S-M relationship and confidence levels ($T_o = 0^{\circ}\text{C}$)

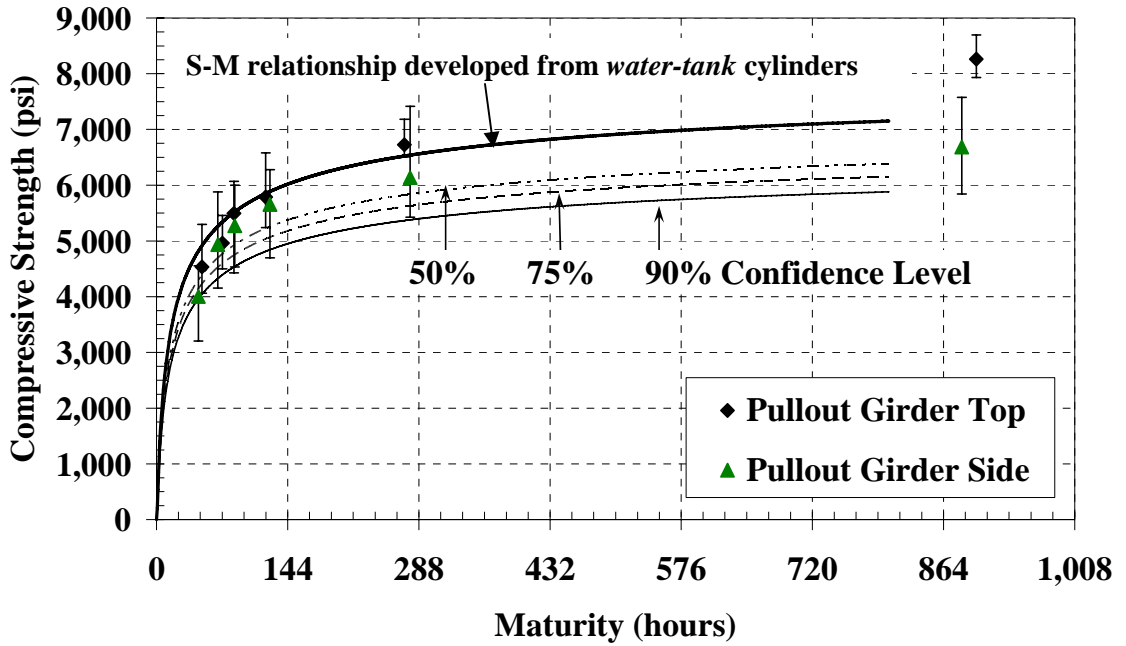

Figure B-30: Pullout test with *water-tank* S-M relationship and confidence levels (E = 33.5 kJ/mol)

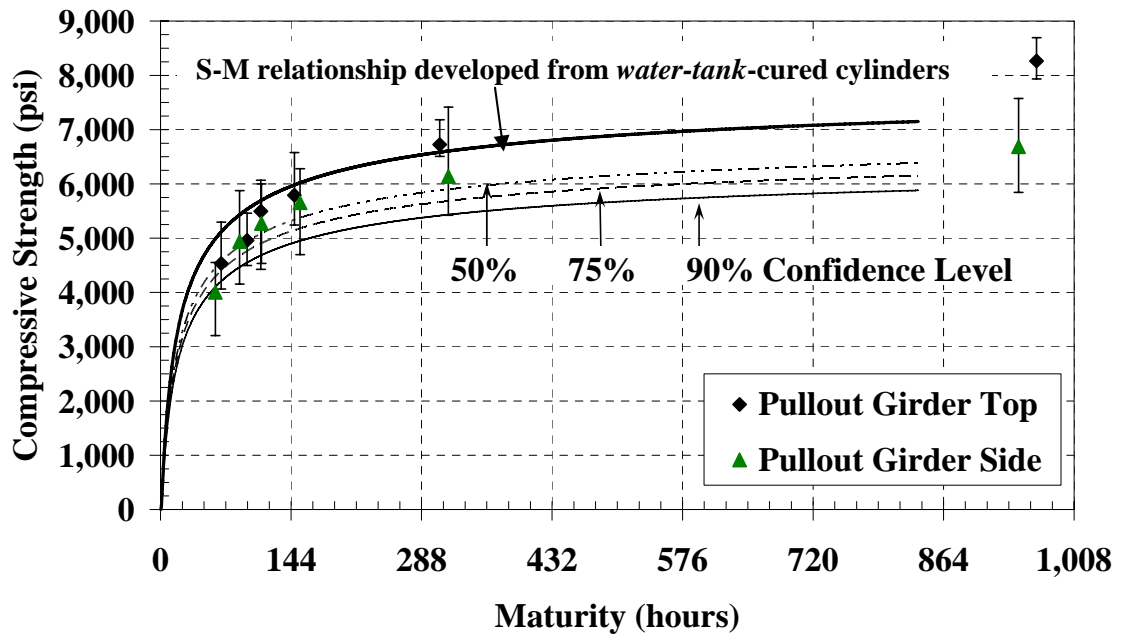

Figure B-31: Pullout test with *water-tank* S-M relationship and confidence levels (E = 40 kJ/mol)

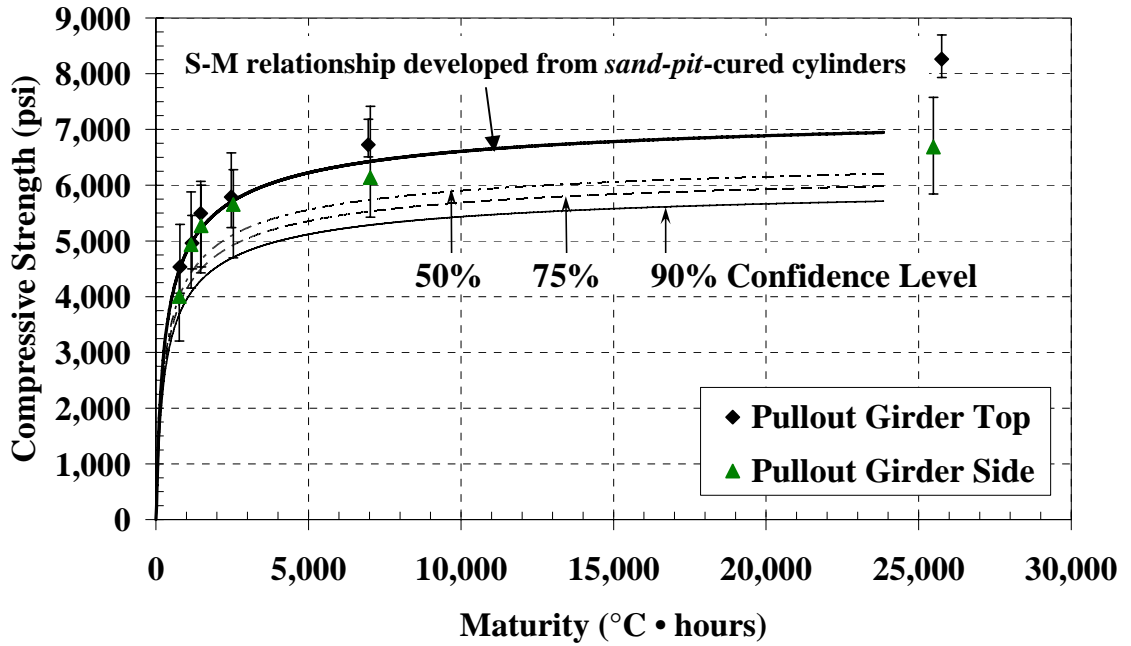

Figure B-32: Pullout test with *sand-pit* S-M relationship and confidence levels ($T_0 = -10^{\circ}\text{C}$)

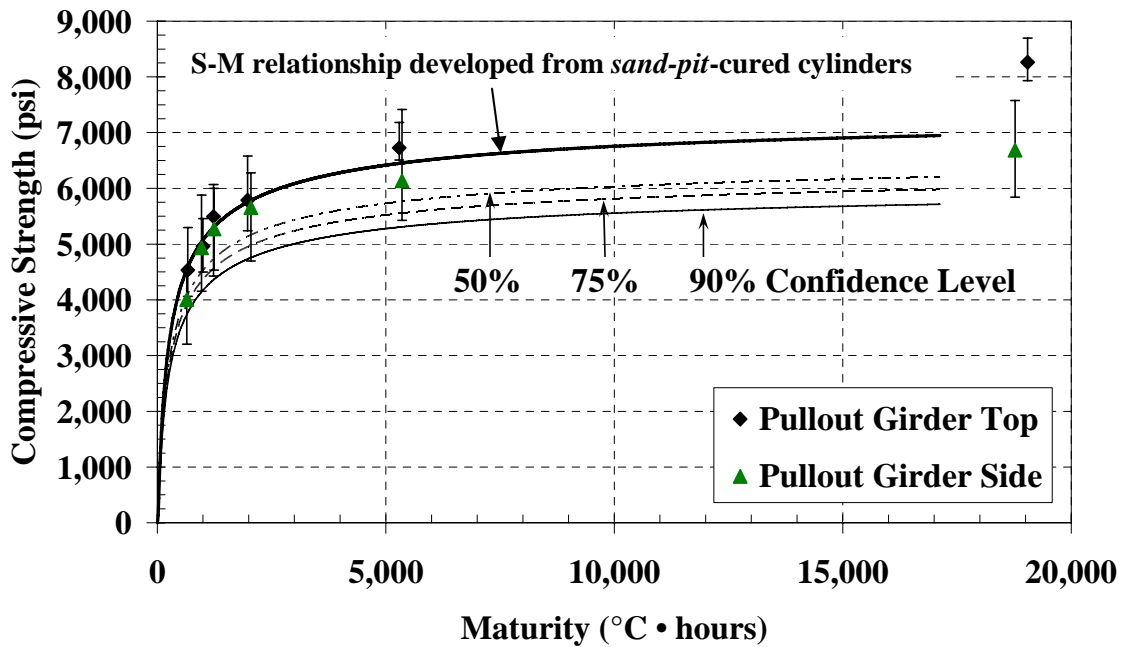

Figure B-33: Pullout test with *sand-pit* S-M relationship and confidence levels ($T_0 = 0^{\circ}\text{C}$)

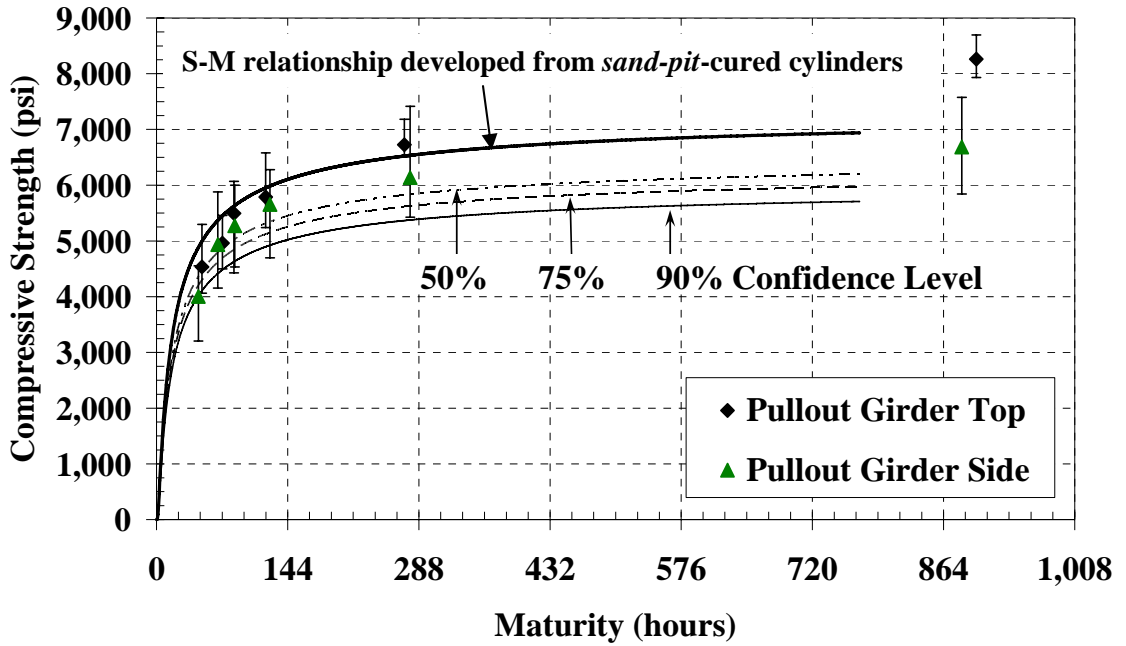

Figure B-34: Pullout test with *sand-pit* S-M relationship and confidence levels (E = 33.5 kJ/mol)

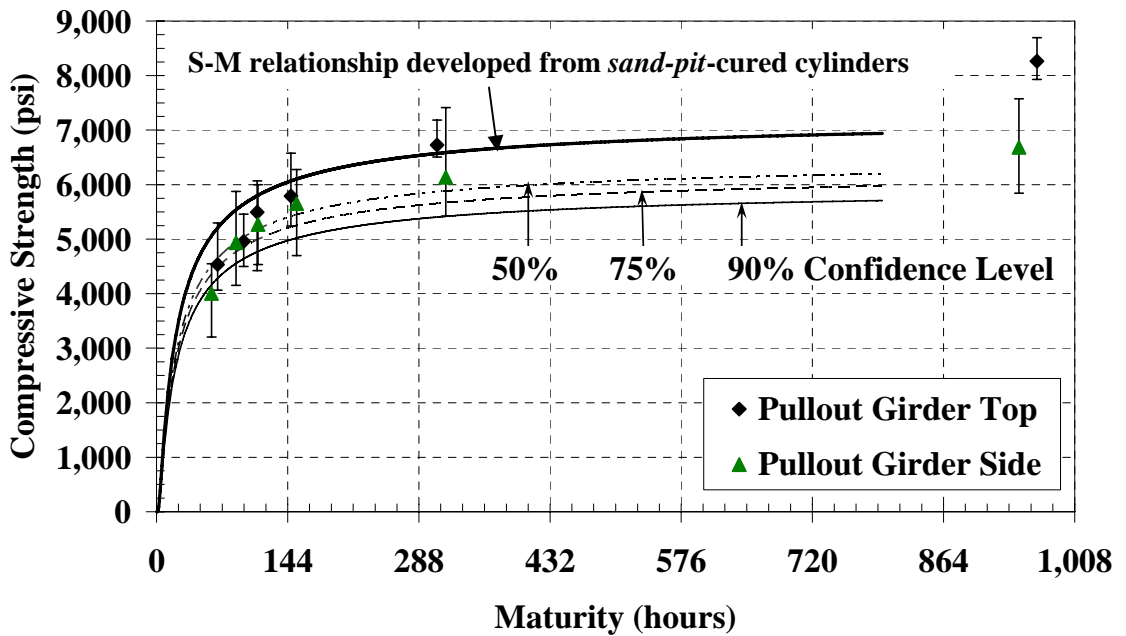

Figure B-35: Pullout test with *sand-pit* S-M relationship and confidence levels (E = 40 kJ/mol)

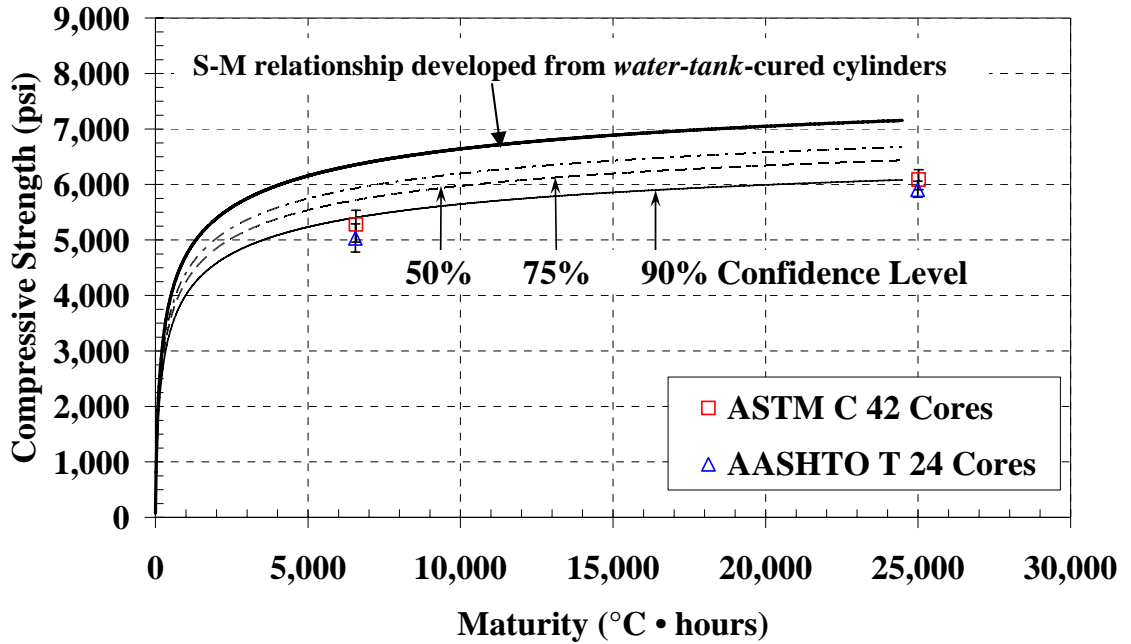

Figure B-36: Cores with *water-tank* S-M relationship and confidence levels ($T_0 = -10^\circ\text{C}$)

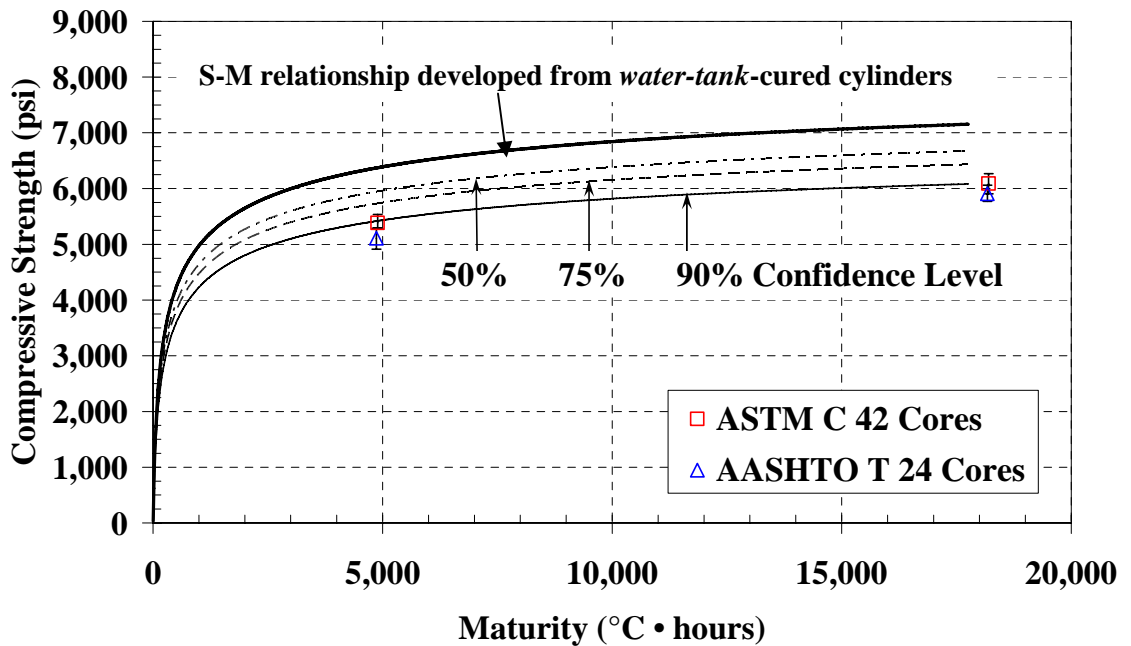

Figure B-37: Cores with *water-tank* S-M relationship and confidence levels ($T_0 = 0^\circ\text{C}$)

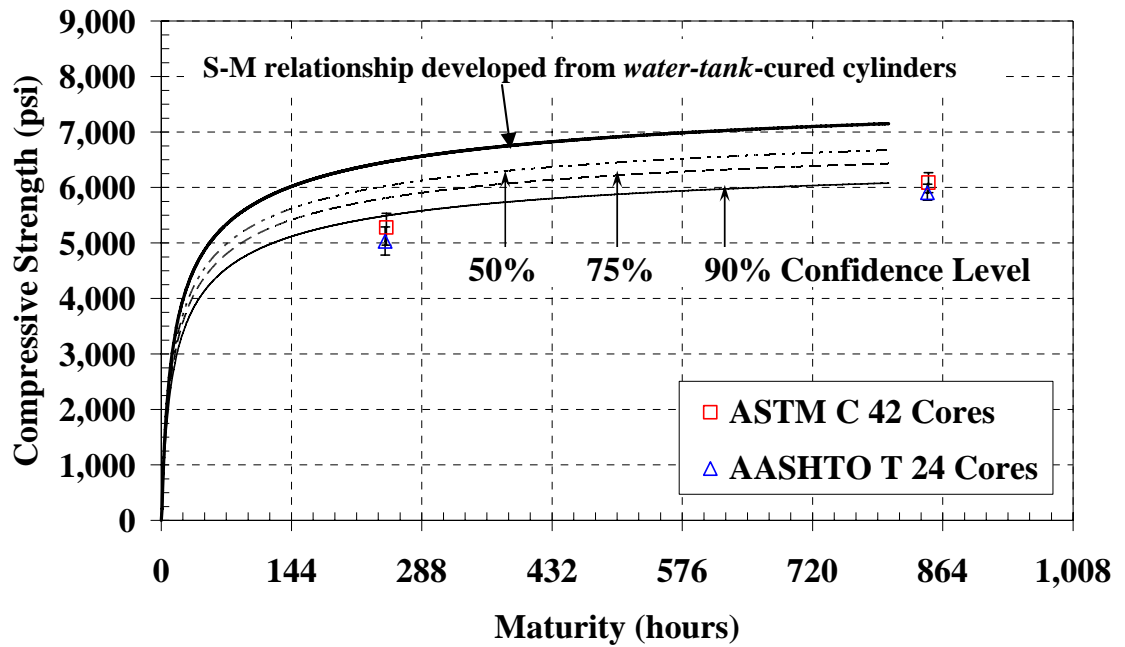

Figure B-38: Cores with *water-tank* S-M relationship and confidence levels ($E = 33.5$ kJ/mol)

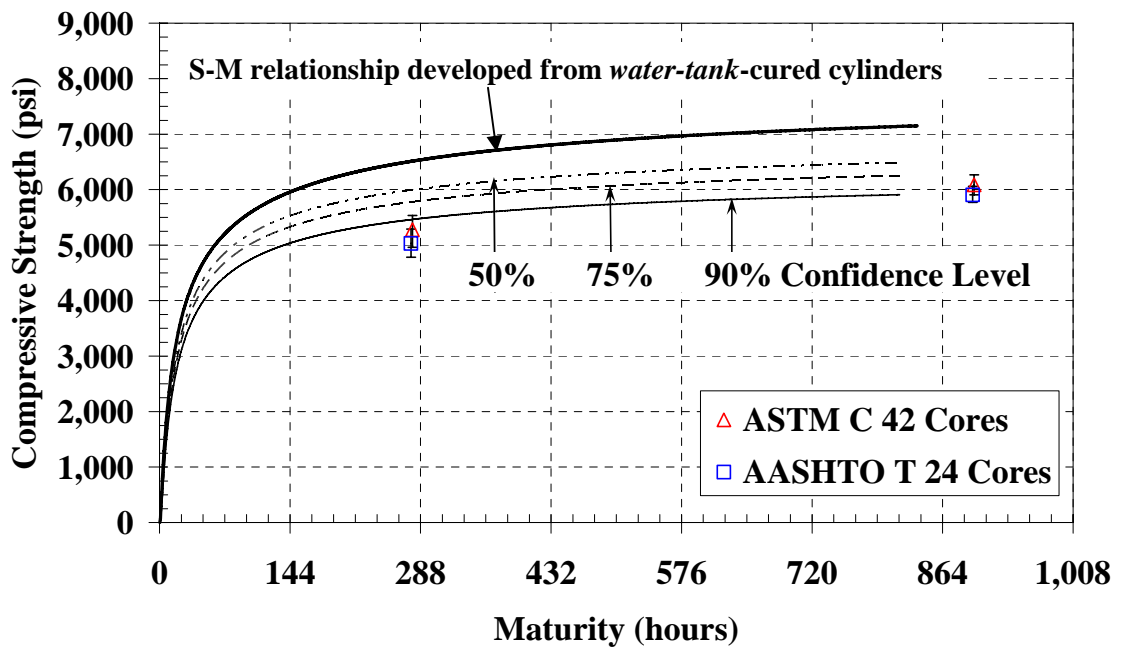

Figure B-39: Cores with *water-tank* S-M relationship and confidence levels ($E = 40$ kJ/mol)

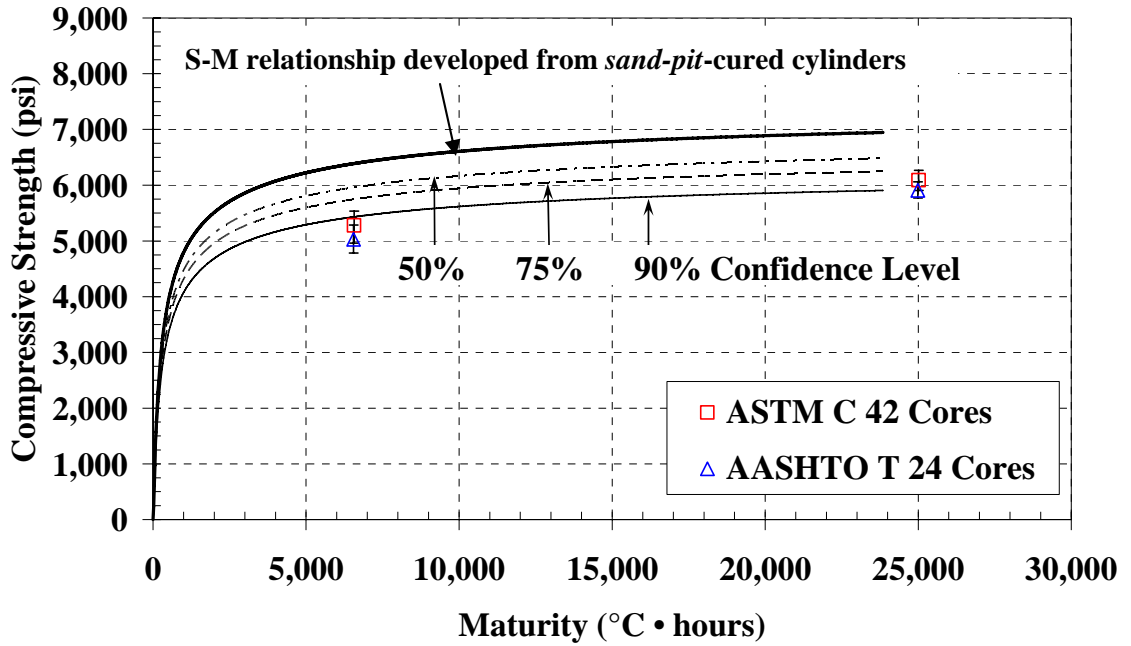

Figure B-40: Cores with *sand pit* S-M relationship and confidence levels ($T_0 = -10^\circ\text{C}$)

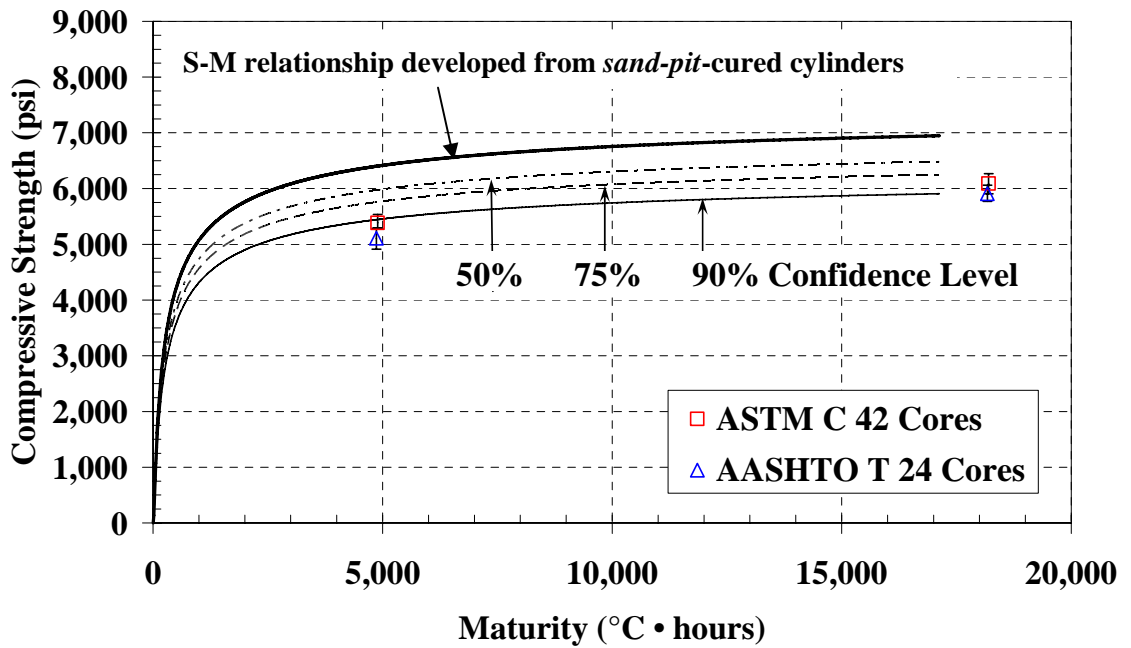

Figure B-41: Cores with *sand-pit* S-M relationship and confidence levels ($T_0 = 0^\circ\text{C}$).

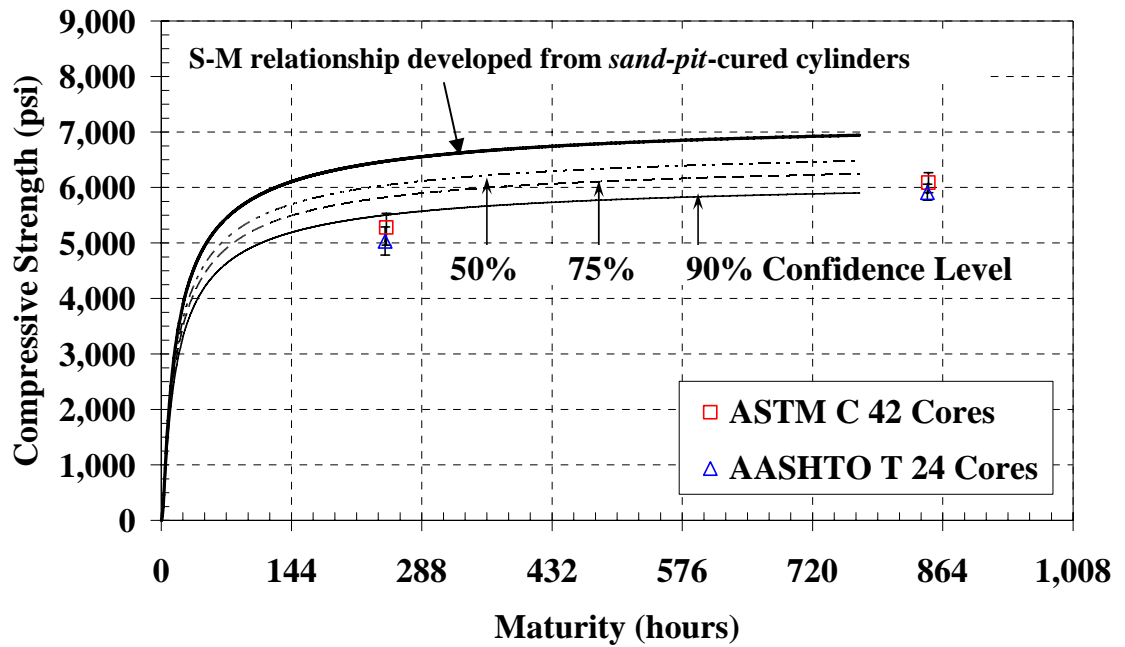

Figure B-42: Cores with *sand-pit* S-M relationship and confidence levels
($E = 33.5$ kJ/mol)

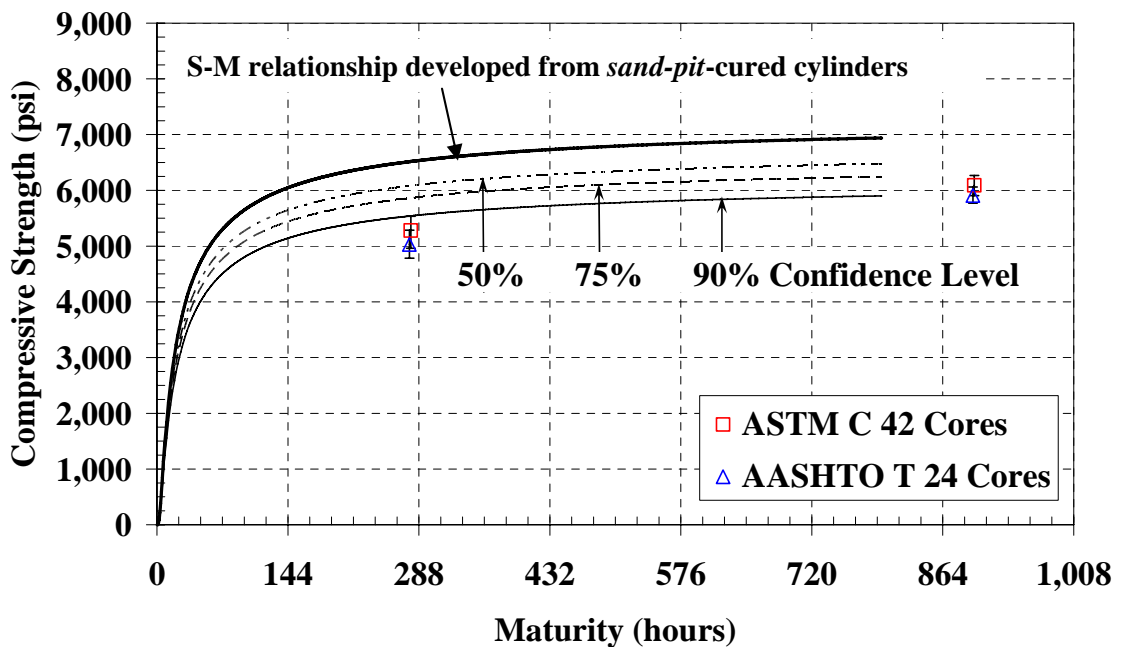

Figure B-43: Cores with *sand-pit* S-M relationship and confidence levels
($E = 40$ kJ/mol)

Table B-12: Estimated strengths using *laboratory* S-M relationship

	Concrete Age (hours)	Measured Strength (psi)	Nurse-Saul Function (psi)		Arrhenius Function (psi)	
			T _o = -10 °C	T _o = 0 °C	E = 40 kJ/mol	E = 33.5 kJ/mol
<i>Lab Cylinders</i>	11.9	3,250	3,470	3,460	3,440	3,450
	20.4	4,500	4,230	4,240	4,260	4,250
	33.7	5,000	4,800	4,800	4,810	4,800
	42.2	4,990	5,030	5,030	5,030	5,030
	66.1	5,330	5,460	5,460	5,450	5,450
	95.3	5,720	5,780	5,780	5,770	5,780
	168.2	6,080	6,200	6,200	6,200	6,200
	671.9	7,000	6,890	6,900	6,900	6,900
<i>Sand Pit Cylinder</i>	8.1	3,600	3,250	3,330	3,870	3,680
	12.2	4,400	3,810	3,890	4,330	4,180
	18.4	4,690	4,230	4,290	4,620	4,500
	24.2	5,070	4,550	4,590	4,850	4,760
	48.5	5,330	5,240	5,260	5,400	5,340
	96.0	6,170	5,810	5,820	5,880	5,860
	168.0	6,110	6,220	6,220	6,260	6,250
	671.3	7,050	6,910	6,920	6,940	6,930
<i>Water Tank Cylinder</i>	8.1	3,600	3,240	3,320	3,820	3,650
	12.2	4,400	3,790	3,870	4,290	4,140
	18.4	4,690	4,200	4,250	4,560	4,440
	24.4	4,980	4,530	4,570	4,810	4,720
	48.5	5,280	5,210	5,230	5,350	5,300
	96.0	5,850	5,810	5,820	5,880	5,860
	168.6	6,190	6,220	6,230	6,270	6,250
	671.5	7,240	6,920	6,930	6,960	6,940

Table B-13: Estimated strengths using *water-tank* S-M relationship

	Concrete Age (hours)	Measured Strength (psi)	Nurse-Saul Function (psi)		Arrhenius Function (psi)	
			T _o = -10 °C	T _o = 0 °C	E = 40 kJ/mol	E = 33.5 kJ/mol
<i>Lab Cylinders</i>	11.9	3,250	4,010	3,950	3,480	3,670
	20.4	4,500	4,580	4,550	4,260	4,380
	33.7	5,000	5,030	5,010	4,800	4,890
	42.2	4,990	5,220	5,200	5,030	5,100
	66.1	5,330	5,590	5,570	5,460	5,510
	95.3	5,720	5,880	5,870	5,800	5,830
	168.2	6,080	6,300	6,290	6,260	6,280
	671.9	7,000	7,120	7,100	7,080	7,090
<i>Sand Pit Cylinder</i>	8.1	3,600	3,850	3,850	3,880	3,870
	12.2	4,400	4,270	4,280	4,330	4,310
	18.4	4,690	4,580	4,590	4,620	4,610
	24.2	5,070	4,830	4,840	4,850	4,840
	48.5	5,330	5,390	5,400	5,400	5,400
	96.0	6,170	5,910	5,910	5,910	5,910
	168.0	6,110	6,310	6,310	6,330	6,320
	671.3	7,050	7,140	7,140	7,130	7,130
<i>Water Tank Cylinder</i>	8.1	3,600	3,850	3,840	3,840	3,850
	12.2	4,400	4,250	4,260	4,290	4,280
	18.4	4,690	4,560	4,560	4,550	4,550
	24.4	4,980	4,820	4,820	4,800	4,810
	48.5	5,280	5,370	5,370	5,350	5,360
	96.0	5,850	5,910	5,910	5,910	5,910
	168.6	6,190	6,320	6,320	6,340	6,330
	671.5	7,240	7,150	7,150	7,150	7,150

Table B-14: Estimated strengths using *sand-pit* S-M relationship

	Concrete Age (hours)	Measured Strength (psi)	Nurse-Saul Function (psi)		Arrhenius Function (psi)	
			T _o = -10 °C	T _o = 0 °C	E = 40 kJ/mol	E = 33.5 kJ/mol
<i>Lab Cylinders</i>	11.9	3,250	3,960	3,880	3,230	3,490
	20.4	4,500	4,640	4,600	4,220	4,370
	33.7	5,000	5,140	5,110	4,850	4,960
	42.2	4,990	5,340	5,320	5,110	5,200
	66.1	5,330	5,710	5,690	5,560	5,620
	95.3	5,720	5,980	5,970	5,900	5,930
	168.2	6,080	6,340	6,340	6,310	6,330
	671.9	7,000	6,930	6,930	6,910	6,920
<i>Sand Pit Cylinder</i>	8.1	3,600	3,760	3,750	3,750	3,750
	12.2	4,400	4,270	4,280	4,310	4,290
	18.4	4,690	4,640	4,650	4,640	4,640
	24.2	5,070	4,920	4,920	4,910	4,910
	48.5	5,330	5,520	5,520	5,500	5,510
	96.0	6,170	6,010	6,000	6,010	6,010
	168.0	6,110	6,350	6,350	6,370	6,370
	671.3	7,050	6,950	6,950	6,940	6,940
<i>Water Tank Cylinder</i>	8.1	3,600	3,750	3,740	3,700	3,720
	12.2	4,400	4,250	4,260	4,250	4,250
	18.4	4,690	4,610	4,610	4,560	4,580
	24.4	4,980	4,910	4,900	4,860	4,870
	48.5	5,280	5,500	5,490	5,450	5,470
	96.0	5,850	6,010	6,010	6,000	6,010
	168.6	6,190	6,360	6,360	6,380	6,370
	671.5	7,240	6,950	6,960	6,950	6,950

Table B-15: Pullout cube estimated strength from *water-tank* S-M relationship (psi)

Concrete Age (hours)	Nurse-Saul Function		Arrhenius Function		Measured Strength (psi)
	T _o = -10 °C	T _o = 0 °C	E = 33.5 kJ/mol	E = 40 kJ/mol	
19.0	4,770	4,820	4,990	5,090	5,330
49.7	5,470	5,490	5,570	5,630	5,740
167.7	6,330	6,340	6,380	6,410	7,040

Table B-16: Mock girder estimated pullout strength using *laboratory* S-M relationship

Concrete Age (hours)	Test Area	Measured Strength (psi)	Nurse-Saul Function (psi)		Arrhenius Function (psi)	
			T _o = -10 °C	T _o = 0 °C	E = 40 kJ/mol	E = 33.5 kJ/mol
12.2	Top	4,530	4,080	4,230	5,120	4,840
	Side	4,010	4,050	4,180	4,990	4,730
18.4	Top	4,960	4,620	4,760	5,530	5,280
	Side	4,940	4,590	4,720	5,430	5,200
24.1	Top	5,500	4,880	5,010	5,670	5,460
	Side	5,270	4,890	5,030	5,680	5,470
49.2	Top	5,790	5,450	5,530	5,950	5,800
	Side	5,650	5,480	5,560	5,980	5,830
167.2	Top	6,730	6,300	6,330	6,490	6,420
	Side	6,140	6,300	6,340	6,500	6,440
671.2	Top	8,260	6,940	6,960	7,010	6,980
	Side	6,690	6,940	6,950	7,000	6,980

Table B-17: Mock girder estimated pullout strength using *water-tank* S-M relationship

Concrete Age (hours)	Test Area	Measured Strength (psi)	Nurse-Saul Function (psi)		Arrhenius Function (psi)	
			T _o = -10 °C	T _o = 0 °C	E = 40 kJ/mol	E = 33.5 kJ/mol
12.2	Top	4,530	4,470	4,540	5,120	4,920
	Side	4,010	4,440	4,510	4,990	4,820
18.4	Top	4,960	4,890	4,980	5,530	5,340
	Side	4,940	4,860	4,940	5,430	5,260
24.1	Top	5,500	5,100	5,190	5,690	5,510
	Side	5,270	5,110	5,200	5,700	5,520
49.2	Top	5,790	5,580	5,640	5,980	5,850
	Side	5,650	5,600	5,670	6,020	5,890
167.2	Top	6,730	6,400	6,430	6,580	6,520
	Side	6,140	6,400	6,440	6,610	6,540
671.2	Top	8,260	7,180	7,190	7,210	7,200
	Side	6,690	7,170	7,180	7,200	7,190

Table B-18: Mock girder estimated pullout strength using *sand-pit* S-M relationship

Concrete Age (hours)	Test Area	Measured Strength (psi)	Nurse-Saul Function (psi)		Arrhenius Function (psi)	
			T _o = -10 °C	T _o = 0 °C	E = 40 kJ/mol	E = 33.5 kJ/mol
12.2	Top	4,530	4,510	4,590	5,210	5,000
	Side	4,010	4,480	4,550	5,060	4,890
18.4	Top	4,960	4,990	5,080	5,640	5,450
	Side	4,940	4,960	5,040	5,540	5,370
24.1	Top	5,500	5,210	5,300	5,800	5,630
	Side	5,270	5,220	5,310	5,800	5,630
49.2	Top	5,790	5,700	5,750	6,070	5,950
	Side	5,650	5,720	5,780	6,100	5,990
167.2	Top	6,730	6,420	6,450	6,570	6,520
	Side	6,140	6,430	6,460	6,590	6,540
671.2	Top	8,260	6,970	6,980	6,990	6,980
	Side	6,690	6,970	6,980	6,980	6,980

Table B-19: Core test estimated strength using *laboratory* S-M relationship (psi)

Concrete Age (Days)	Curing Method	Measured Strength (psi)	Nurse-Saul Function		Arrhenius Function	
			T _o = -10 °C	T _o = 0 °C	E = 40 kJ/mol	E = 33.5 kJ/mol
7.0	ASTM C 42	5,280	6,260	6,280	6,420	6,370
	AASHTO T 24	5,030	6,260	6,280	6,420	6,360
28.0	ASTM C 42	6,090	6,930	6,940	6,980	6,960
	AASHTO T 24	5,910	6,930	6,940	6,980	6,960

Table B-20: Core test estimated strength using *water-tank* S-M relationship (psi)

Concrete Age (Days)	Test Area	Measured Strength (psi)	Nurse-Saul Function		Arrhenius Function	
			T _o = -10 °C	T _o = 0 °C	E = 40 kJ/mol	E = 33.5 kJ/mol
7.0	ASTM C 42	5,280	6,360	6,370	6,510	6,460
	AASHTO T 24	5,030	6,350	6,370	6,510	6,460
28.0	ASTM C 42	6,090	7,160	7,170	7,180	7,170
	AASHTO T 24	5,910	7,160	7,170	7,180	7,170

Table B-21: Core test estimated strength using *sand-pit* S-M relationship (psi)

Concrete Age (Days)	Test Area	Measured Strength (psi)	Nurse-Saul Function		Arrhenius Function	
			T _o = -10 °C	T _o = 0 °C	E = 40 kJ/mol	E = 33.5 kJ/mol
7.0	ASTM C 42	5,280	6,390	6,400	6,520	6,470
	AASHTO T 24	5,030	6,390	6,400	6,510	6,470
28.0	ASTM C 42	6,090	6,960	6,970	6,970	6,970
	AASHTO T 24	5,910	6,960	6,970	6,970	6,970

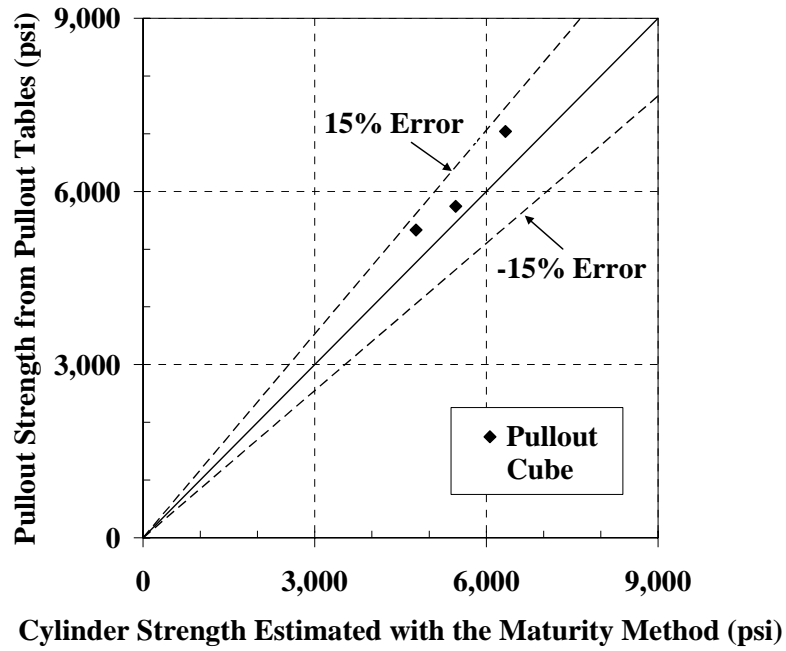

Figure B-44: 45°-line graph to evaluate the pullout table using estimated strength from *water-tank* S-M relationship using the Nurse-Saul maturity function ($T_0 = -10\text{ }^\circ\text{C}$)

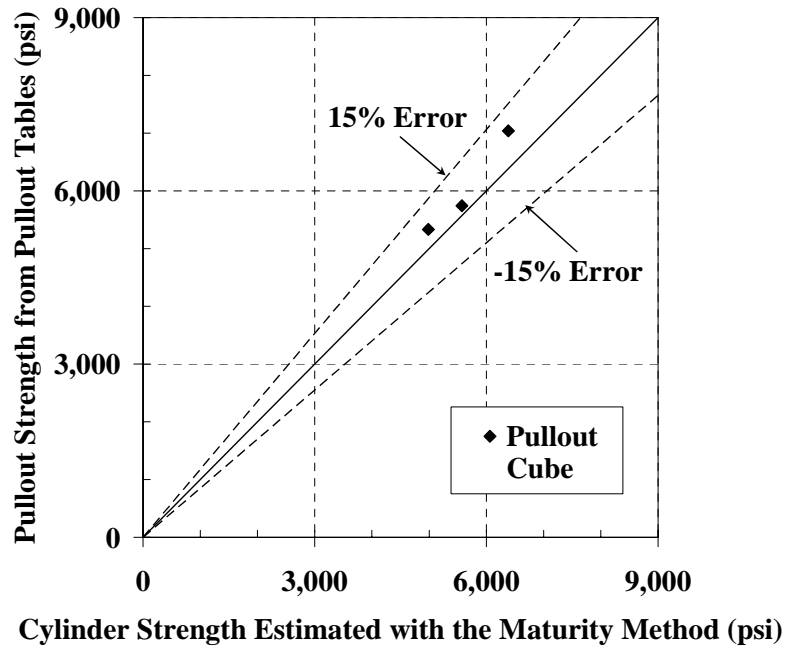

Figure B-45: 45°-line graph to evaluate the pullout table using estimated strength from *water-tank* S-M relationship using the Arrhenius maturity ($E = 33.5\text{ kJ/mol}$)

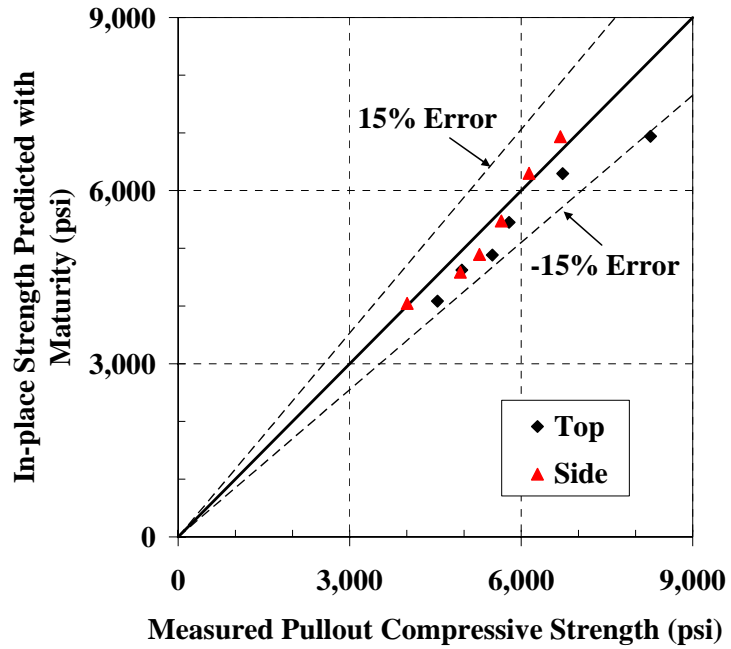

Figure B-46: 45°-line graph for estimating the strength of pullout test on the mock girder using *laboratory* S-M relationship with Nurse-Saul maturity function ($T_0 = -10\text{ }^\circ\text{C}$)

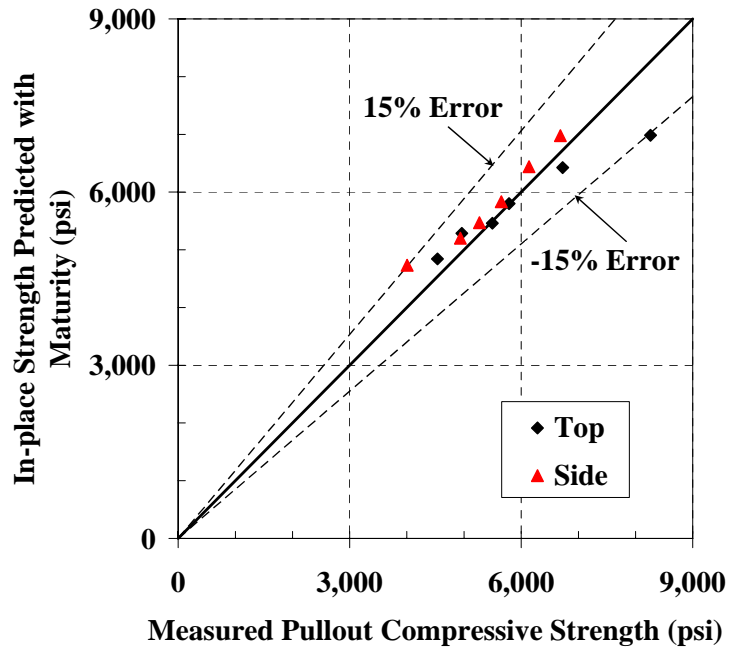

Figure B-47: 45°-line graph for estimating the strength of pullout test on the mock girder using *laboratory* S-M relationship with Arrhenius maturity function ($E = 33.5\text{ kJ/mol}$)

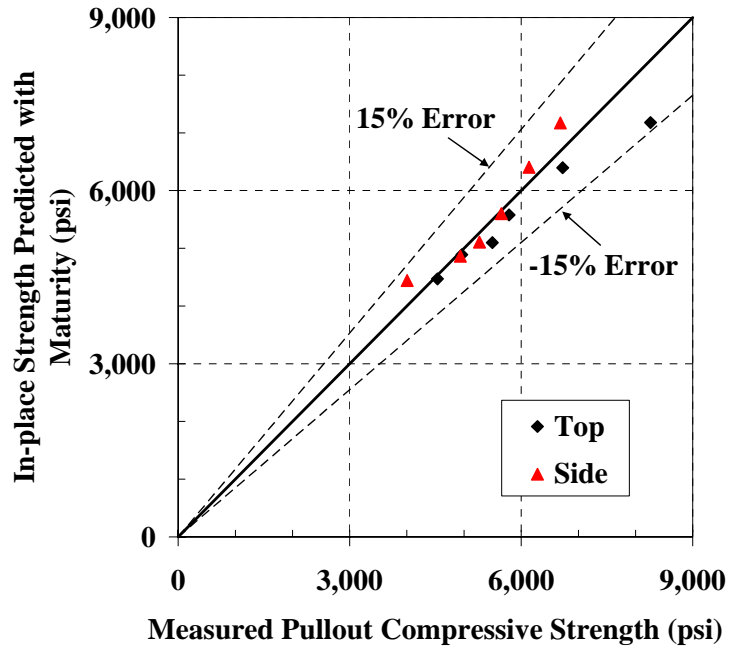

Figure B-48: 45°-line graph for estimating the strength of pullout test on the mock girder using *water-tank* S-M relationship with Nurse-Saul maturity function ($T_o = -10\text{ }^\circ\text{C}$)

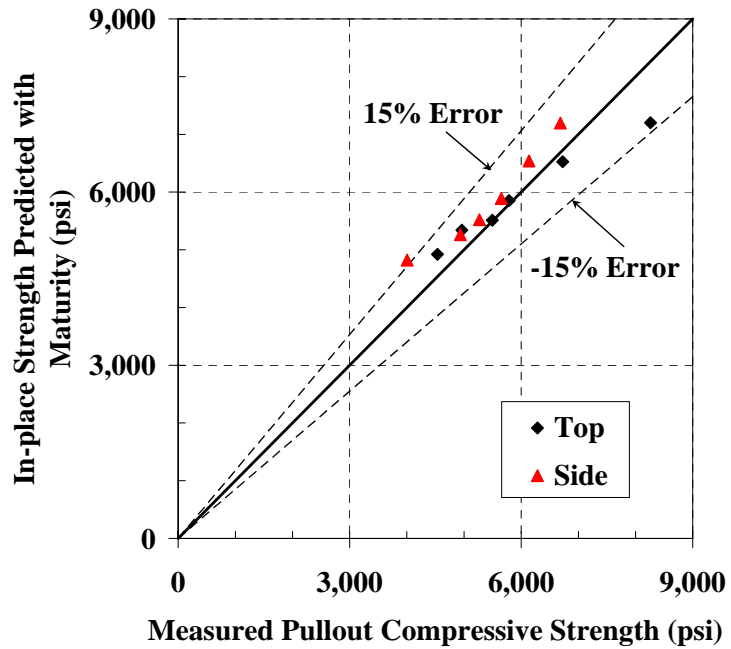

Figure B-49: 45°-line graph for estimating the strength of pullout test on the mock girder using *water-tank* S-M relationship with Arrhenius maturity function ($E = 33.5\text{ kJ/mol}$)

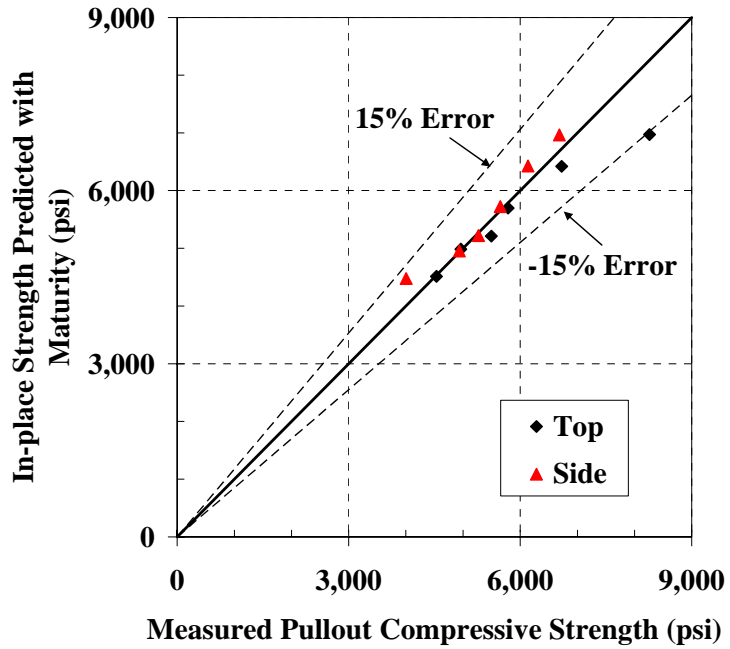

Figure B-50: 45°-line graph for estimating the strength of pullout test on the mock girder using *sand-pit* S-M relationship with Nurse-Saul maturity function ($T_o = -10\text{ }^\circ\text{C}$)

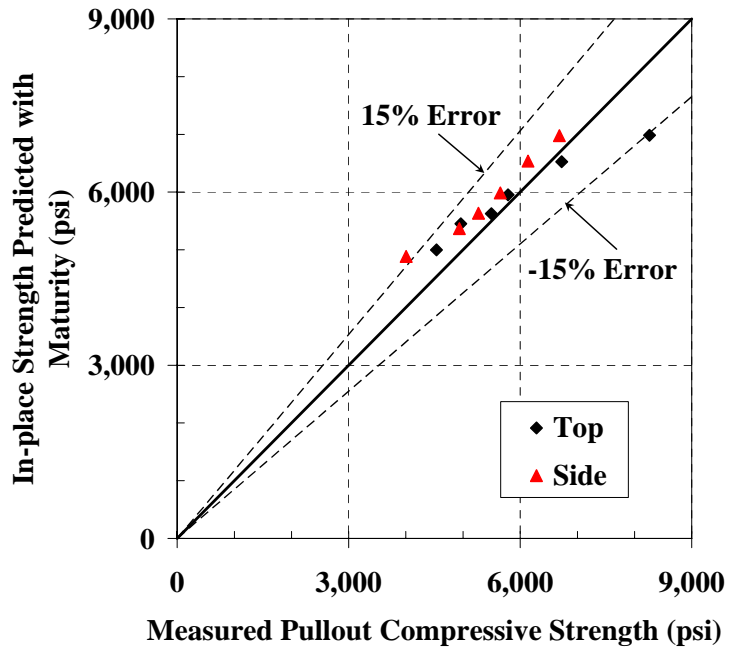

Figure B-51: 45°-line graph for estimating the strength of pullout test on the mock girder using *sand-pit* S-M relationship with Arrhenius maturity function ($E = 33.5\text{ kJ/mol}$)

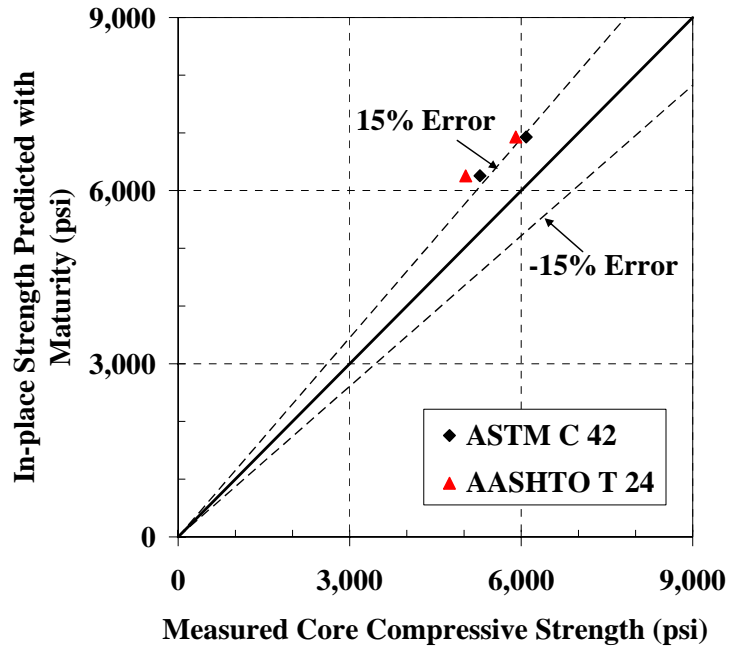

Figure B-52: 45°-line graph for estimating the strength of cores for the mock girder using *laboratory* S-M relationship with Nurse-Saul maturity function test ($T_0 = -10\text{ }^\circ\text{C}$)

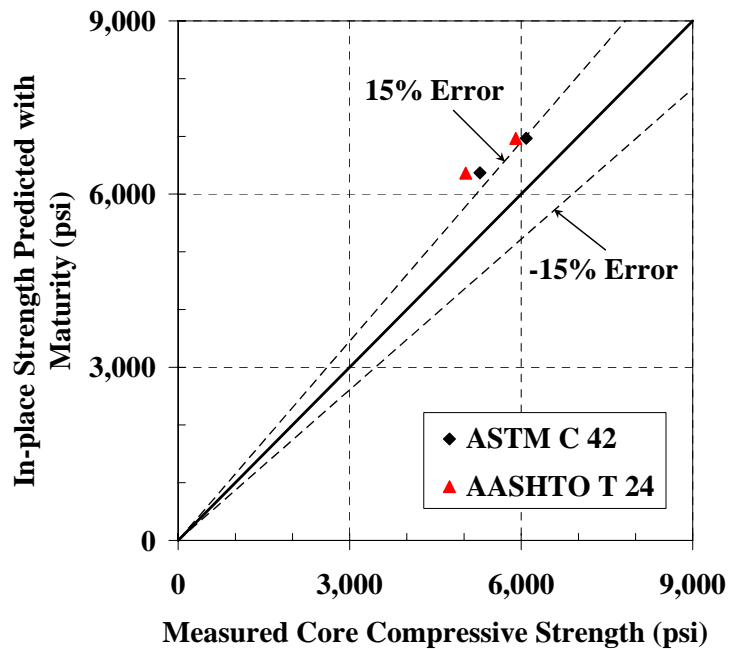

Figure B-53: 45°-line graph for estimating the strength of cores for the mock girder using *laboratory* S-M relationship with Arrhenius maturity function ($E = 33.5\text{ kJ/mol}$)

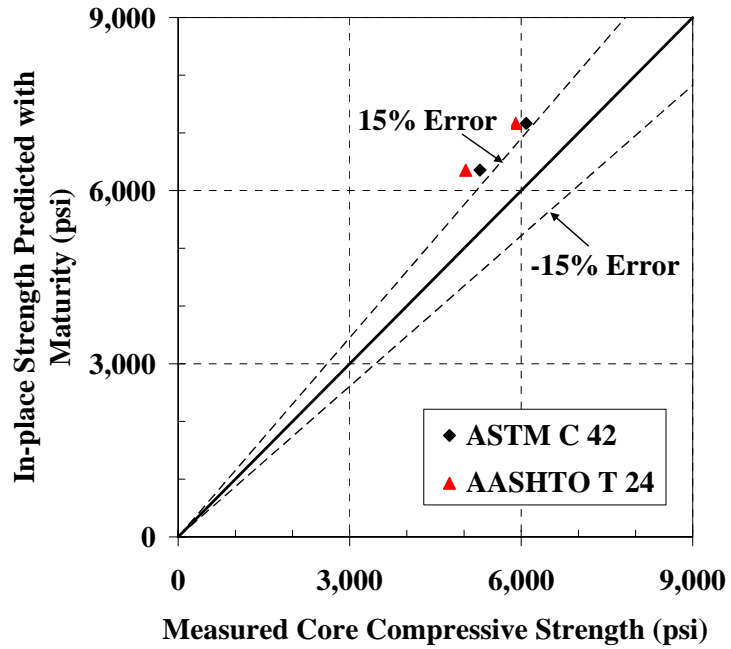

Figure B-54: 45°-line graph for estimating the strength of cores for the mock girder using *water-tank* S-M relationship with Nurse-Saul maturity function ($T_0 = -10\text{ }^\circ\text{C}$)

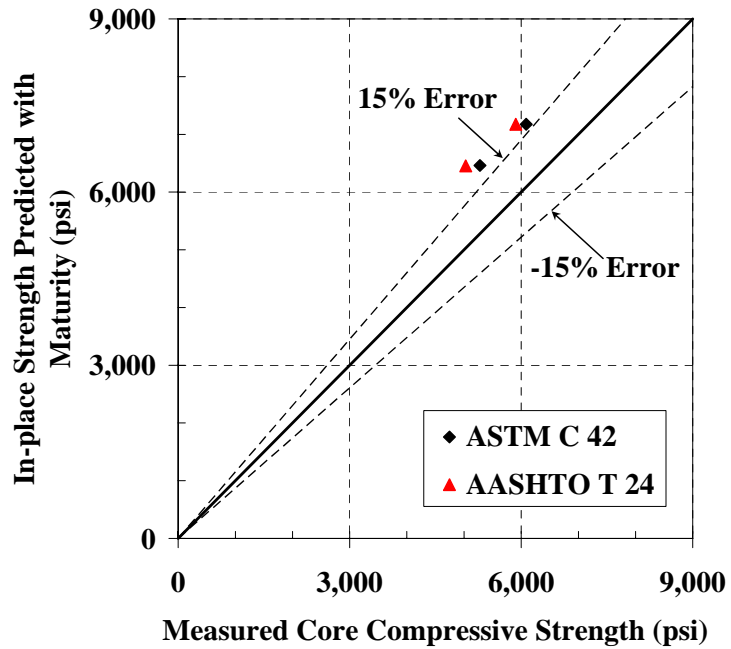

Figure B-55: 45°-line graph for estimating the strength of cores for the mock girder using *water-tank* S-M relationship with Arrhenius maturity function ($E = 33.5\text{ kJ/mol}$)

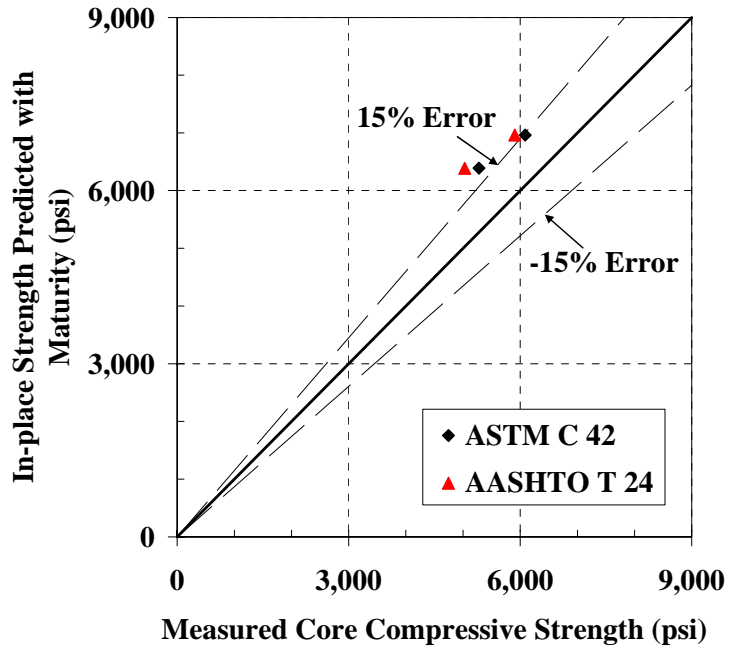

Figure B-56: 45°-line graph for estimating the strength of cores for the mock girder using *sand-pit* S-M relationship with Nurse-Saul maturity function ($T_0 = -10\text{ }^\circ\text{C}$)

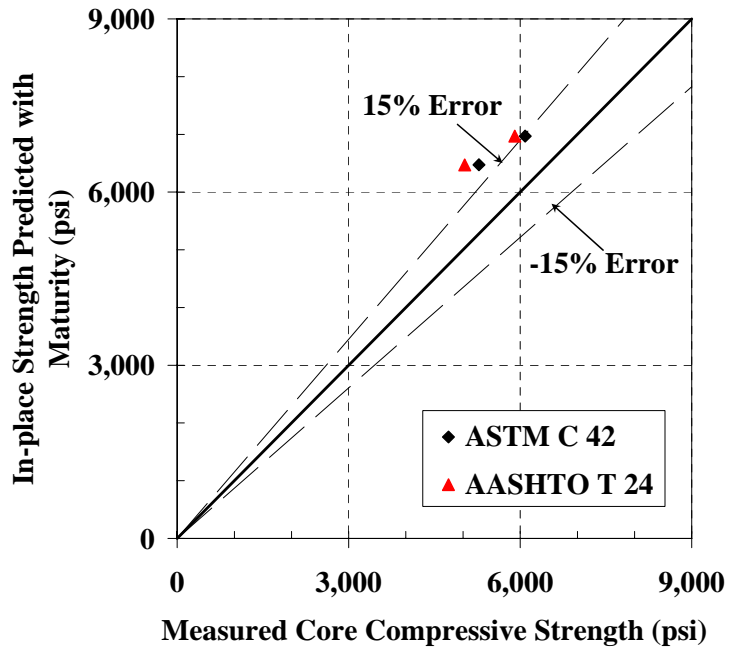

Figure B-57: 45°-line graph for estimating the strength of cores for the mock girder using *sand-pit* S-M relationship with Arrhenius maturity function ($E = 33.5\text{ kJ/mol}$)



Figure B-58: AASTHO type IV forms used



Figure B-59: Prestressed strand being installed



Figure B-60: Steel reinforcement cage (1)



Figure B-61: Steel reinforcement cage (2)



Figure B-62: iButton installation (1)



Figure B-63: iButton installation (2)



Figure B-64: iButton installation (3)



Figure B-65: Sherman prestress medal worker cutting access panel



Figure B-66: Front of access panel



Figure B-67: Back of access panel



Figure B-68: Access panel and side mounted inserts



Figure B-69: Side mounted inserts



Figure B-70: Girder forms and steel cage



Figure B-71: Stirrups, iButtons and girder forms before concrete cast



Figure B-72: Inside of flange of girder form before concrete cast



Figure B-73: Lifting anchor installed in mock girder



Figure B-74: Fresh concrete work area



Figure B-75: Concrete transport



Figure B-76: Concrete transport placing concrete



Figure B-77: Fresh concrete placement



Figure B-78: Fresh concrete being placed in flange



Figure B-79: Curing tarp over mock girder



Figure B-80: Curing blanket covering the concrete specimens



Figure B-81: Top of girder with floating inserts



Figure B-82: Removal of girder forms



Figure B-83: Side insert after girder forms removed



Figure B-84: Side pullout inserts



Figure B-85: Top pullout inserts



Figure B-86: Coring process (1)



Figure B-87: Coring process (2)



Figure B-88: Core removal process



Figure B-89: Core right after removal from girder



Figure B-90: Side pullout insert completely removed



Figure B-91: Top pullout insert completely removed



Figure B-92: Girder final storage area in stock yard



Figure B-93: Girder and field curing tank in stock yard



Figure B-94: Core with iButton installed



Figure B-95: Pullout cube with iButton installed



Figure B-96: iButton installed in mock girder



Figure B-97: Epoxy iButton and spliced connector (1)



Figure B-98: Epoxy obutton and spliced connector (2)

APPENDIX C

**EVALUATION OF THE MATURITY METHOD UNDER BRIDGE DECK
CONSTRUCTION CONDITIONS**

The data collected at the bridge deck project are presented in this appendix. Chapter 5 is the corresponding chapter that details the objectives, experimental design, test layout, analysis approach, results, and conclusions for the evaluation of the maturity method on a bridge deck application. In this appendix all the individual strength data, temperature graphs, extra strength maturity relationships, 45°-line graphs showing estimated strengths for the different maturity function versus the measured strengths, and pictures of the construction and testing process are presented. The data from the cold-weather placement of the mock bridge deck is presented in Section C.1. The data for the warm-weather placement of the mock bridge deck is presented in Section C.2. The data for the evaluation of the use of molded cylinders for verification testing on the actual bridge deck cast at the construction site are presented in Section C.3. As for the graphs and data pertaining to the accuracy of the maturity method, they are presented in Section C.4. Finally, in Section C.5, pictures of the mock bridge deck phase are presented, and pictures of the actual bridge deck construction are given in Section C.6.

C.1 COLD-WEATHER PLACEMENT OF MOCK BRIDGE DECK RESULTS

Table C-1: *Laboratory-cured cylinder strength data for cold-weather placement of mock bridge deck*

Intended Age (days)	Actual Time Tested	Concrete Age (hours)	Compressive Strength (psi)	% Range
1	2/25/05 3:40 PM	26.8	1,020	3.1
			1,040	
			1,050	
2	2/26/05 2:15 PM	49.4	1,980	5.8
			2,070	
			2,100	
3	2/27/05 2:25 PM	73.6	2,570	6.6
			2,740	
			2,590	
7	3/3/05 3:10 PM	170.3	3,670	2.9
			3,640	
			3,750	
14	3/10/05 1:45 PM	336.9	4,290	2.5
			4,400	
			4,310	
28	3/24/05 1:15 PM	672.4	5,110	4.3
			4,890	
			5,050	

Table C-2: *Lime-saturated water-tank-cured* cylinder strength data for cold-weather placement of mock bridge deck

Intended Age (days)	Actual Time Tested	Concrete Age (hours)	Compressive Strength (psi)	% Range
1	2/25/05 3:50 PM	27.0	840	5.6
			*	
			790	
2	2/26/05 2:00 PM	49.2	1,400	5.4
			1,410	
			1,480	
3	2/27/05 2:14 PM	73.4	2,140	0.7
			2,150	
			2,140	
7	3/3/05 3:00 PM	170.2	3,590	3.3
			3,530	
			3,650	
14	3/10/05 12:45 PM	335.9	4,380	1.1
			4,330	
			4,380	
28	3/24/05 1:10 PM	672.3	4,820	7.0
			4,650	
			4,490	

* Indicates cylinder data removed due to outliers

Table C-3: Lime-saturated water-tank-cured 4 x 8 inch strength data for cold-weather placement of mock bridge deck

Intended Age (days)	Actual Time Tested	Concrete Age (hours)	Compressive Strength (psi)	% Range
1	2/25/05 3:25 PM	26.6	770	3.2
			750	
			760	
2	2/26/05 3:05 PM	50.3	1,310	2.6
			*	
			1,350	
7	3/3/05 3:25 PM	170.6	3,490	7.2
			3,570	
			3,320	
28	3/24/05 1:10 PM	672.3	4,840	8.2
			4,840	
			5,240	

* Indicates 4 x 8 test removed due to outliers

Table C-4: Cast-in-place strength data for cold-weather placement of mock bridge deck

Intended Age (days)	Actual Time Tested	Concrete Age (hours)	Compressive Strength (psi)	% Range
1	2/25/05 3:15 PM	26.4	1,820	4.4
			1,900	
			1,890	
2	2/26/05 3:20 PM	50.5	2,800	1.9
			2,740	
			-	
7	3/3/05 3:30 PM	170.7	3,920	2.4
			3,830	
			*	
28	3/24/05 1:21 PM	672.5	*	2.9
			4,900	
			5,050	

* Indicates CIP test removed due to outliers

- Indicates no CIP data due to cylinder breaking on extraction

Table C-5: Top pullout strength data for cold-weather placement of mock bridge deck

Intended Age (days)	Actual Time Tested	Concrete Age (hours)	Pullout Load (kN)	Compressive Strength (psi)	% Range
1	2/25/05 2:30 PM	25.7	13.0	1,850	36.2
			13.4	1,910	
			12.2	1,730	
			9.5	1,330	
			13.8	1,970	
2	2/26/05 12:30 PM	47.7	17.9	2,580	11.0
			19.0	2,750	
			12.0	*	
			22.2	*	
			17.1	2,460	
3	2/27/05 1:00 PM	72.2	20.6	2,990	33.9
			19.2	2,780	
			26.0	3,850	
			20.8	3,020	
			21.2	3,080	
7	3/3/05 1:40 PM	168.8	14.1	*	15.7
			23.1	3,370	
			21.8	3,170	
			25.3	3,720	
			24.8	3,630	
14	3/10/05 11:55 AM	335.1	33.2	5,150	32.7
			31.3	4,810	
			24.8	3,630	
			32.4	5,010	
			30.9	4,730	
28	3/24/05 12:00 PM	671.2	28.3	4,260	15.7
			26.9	4,010	
			24.9	3,650	
			35.2	*	
			28.4	4,280	

* Indicates pullout test removed due to outliers

- Indicates no pullout data due to failure to conduct test on mock bridge deck

Table C-6: Side pullout strength data for cold-weather placement of mock bridge deck

Intended Age (days)	Actual Time Tested	Concrete Age (hours)	Pullout Load (kN)	Compressive Strength (psi)	% Range
1	2/25/05 2:30 PM	25.7	11.0	1,550	30.5
			10.3	1,450	
			12.9	1,830	
			9.7	1,360	
			11.2	1,580	
2	2/26/05 12:30 PM	47.7	19.5	2,830	29.0
			18.5	2,680	
			17.9	2,580	
			20.6	2,990	
			15.5	2,220	
3	2/27/05 1:00 PM	72.2	22.6	3,290	22.7
			20.9	3,040	
			18.2	2,630	
			19.5	2,830	
			19.8	2,870	
7	3/3/05 1:40 PM	168.8	24.8	3,630	29.1
			23.7	3,460	
			30.3	4,630	
			28.2	4,240	
			27.3	4,080	
14	3/10/05 11:55 AM	335.1	23.6	*	10.1
			30.0	4,570	
			-	-	
			27.9	4,190	
			27.6	4,140	
28	3/24/05 12:00 PM	671.2	25.6	3,770	35.8
			24.4	*	
			25.9	3,830	
			35.9	*	
			34.1	5,310	

* Indicates pullout test removed due to outliers

- Indicates no pullout data due to failure to conduct test on mock bridge deck

Table C-7: Bottom pullout strength data for cold-weather placement of mock bridge deck

Intended Age (days)	Actual Time Tested	Concrete Age (hours)	Pullout Load (kN)	Compressive Strength (psi)	% Range
1	2/25/05 2:30 PM	25.7	11.8	1,670	11.1
			12.3	1,750	
			11.8	1,670	
			12.5	1,780	
			13.1	1,860	
2	2/26/05 12:30 PM	47.7	17.8	2,570	35.7
			17.3	2,490	
			16.6	2,390	
			21.2	3,080	
			15.2	2,180	
3	2/27/05 1:00 PM	72.2	24.7	3,610	28.9
			24.3	3,550	
			34.4	*	
			25.3	3,720	
			18.9	2,740	
7	3/3/05 1:40 PM	168.8	17.7	*	32.3
			28.4	4,280	
			28.2	4,240	
			20.7	3,010	
			28.1	4,230	
14	3/10/05 11:55 AM	335.1	25.4	3,740	34.9
			-	-	
			20.9	3,040	
			28.5	4,300	
			23.1	3,370	
28	3/24/05 12:00 PM	671.2	17.2	*	25.1
			24.5	3,580	
			27.5	4,120	
			30.2	4,610	
			27.2	4,060	

* Indicates pullout test removed due to outliers

- Indicates no pullout data due to failure to conduct test on mock bridge deck

Table C-8: Pullout cube strength data for cold-weather placement of mock bridge deck

Intended Age (days)	Actual Time Tested	Concrete Age (hours)	Pullout Load (kN)	Compressive Strength (psi)	% Range
1	2/25/05 3:04 PM	26.2	9.5	1,330	34.2
			8.9	1,240	
			8.1	1,120	
			7.4	1,020	
			6.9	950	
			7.8	1,080	
			8.4	1,170	
			10.2	*	
2	2/26/05 1:17 PM	48.5	15.5	*	31.8
			13.2	1,880	
			13.0	1,850	
			12.7	1,810	
			9.7	1,360	
			10.7	1,510	
			10.7	1,510	
			10.8	1,520	
7	3/3/05 2:23 AM	157.6	22.0	3,204	19.8
			21.0	3,050	
			20.8	3,020	
			21.3	3,100	
			19.6	2,840	
			23.7	3,460	
			20.3	2,950	
			23.5	3,430	

* Indicates pullout data remove due to being an outlier

Figure C-1: Top of mock bridge deck core numbering

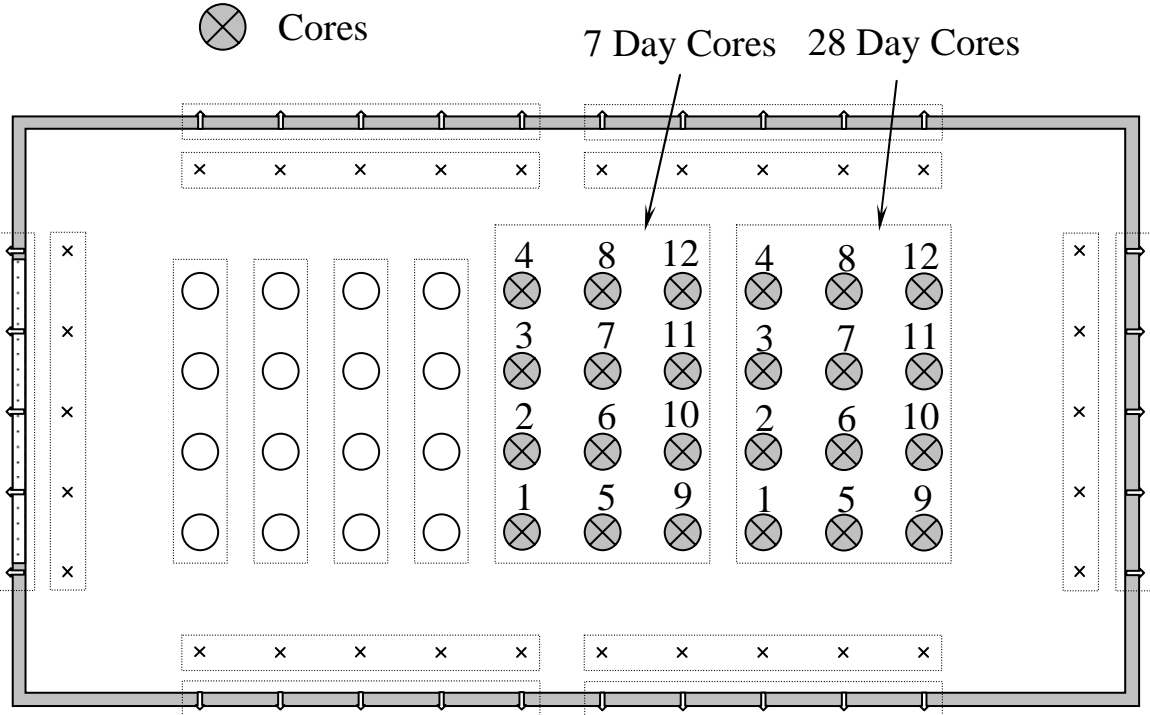

Table C-9: ASTM C 42 core strength data for cold-weather placement of mock bridge deck

Intended Age	Actual Time Tested	Concrete Age (hours)	Compressive Strength (psi)	% Range
10 Day	3/6/05 5:10 PM	244.3	3,880	11.5
			4,100	
			4,350	
			3,950	
			-	
28 Day	3/26/05 10:18 AM	717.5	*	5.7
			4,780	
			4,660	
			*	
			4,520	

* Indicates core test removed due to outliers

- Indicates no core data due to failure to remove from mock bridge deck

Table C-10: ASTM C42 core dimensions for cold-weather placement of mock bridge deck

Intended Age	Core Number	Diameter (in.)				Length (in.)		L/D
		1	2	Avg.	% Diff.	Before Capping	After Capping	
10 Day	2	3.97	3.98	3.98	0.25%	8.0	8.3	2.01
	4	3.98	3.99	3.99	0.25%	8.0	8.4	2.01
	6	3.98	3.98	3.98	0.00%	8.1	8.3	2.02
	10	3.99	3.98	3.99	0.25%	8.0	8.2	1.99
	12	-	-	-	-	-	-	-
28 Day	1	3.98	3.98	3.98	0.00%	7.9	8.3	1.98
	3	3.98	3.98	3.98	0.00%	8.0	8.2	2.01
	5	3.98	3.98	3.98	0.00%	8.0	8.3	2.01
	7	3.98	3.98	3.98	0.00%	7.9	8.2	1.98
	9	3.98	3.98	3.98	0.00%	8.0	8.2	2.01

- Indicates no core data due to failure to remove from mock bridge deck

Table C-11: AASHTO T 24 core strength data for cold-weather placement of mock bridge deck

Intended Age	Actual Time Tested	Concrete Age (hours)	Compressive Strength (psi)	% Range
10 Day	3/6/05 5:00 PM	244.2	4,180	11.2
			3,980	
			4,010	
			3,730	
			-	
28 Day	3/26/05 9:55 AM	717.1	4,330	5.1
			4,160	
			*	
			4,310	
			4,390	

* Indicates cores removed due to outliers

- Indicates no core data due to failure to remove from mock bridge deck

Table C-12: AASHTO T 24 core dimensions for cold-weather placement of mock bridge deck

Intended Age	Core Number	Diameter (in.)				Length (in.)		L/D
		1	2	Avg.	% Diff.	Before Capping	After Capping	
10 Day	1	3.98	3.98	3.98	0.00%	8.0	8.3	2.01
	3	3.98	3.98	3.98	0.00%	8.0	8.3	2.00
	5	3.98	3.98	3.98	0.00%	8.1	8.3	2.02
	9	3.99	3.98	3.99	0.25%	8.0	8.3	1.99
	11	-	-	-	-	-	-	-
28 Day	2	4.00	3.98	3.99	0.50%	7.9	8.3	1.98
	4	3.98	3.98	3.98	0.00%	8.0	8.3	2.01
	6	3.98	3.98	3.98	0.00%	8.0	8.2	2.01
	8	3.99	3.98	3.99	0.25%	8.0	8.2	2.01
	10	3.99	3.98	3.99	0.25%	8.0	8.2	2.01

- Indicates no core data due to failure to remove from mock bridge deck

All temperature data for the cold-weather placement of the mock bridge deck are given below. Figure C-2 shows the ambient temperatures for the entire project. The remaining temperature graphs only show the first seven days of data. The remaining temperatures were not shown because the temperatures of the specimens and mock bridge deck follow the ambient temperatures fairly closely. The first seven days were graphed to show the hydration of the concrete. The temperature sensor at location 6 top was lost during construction.

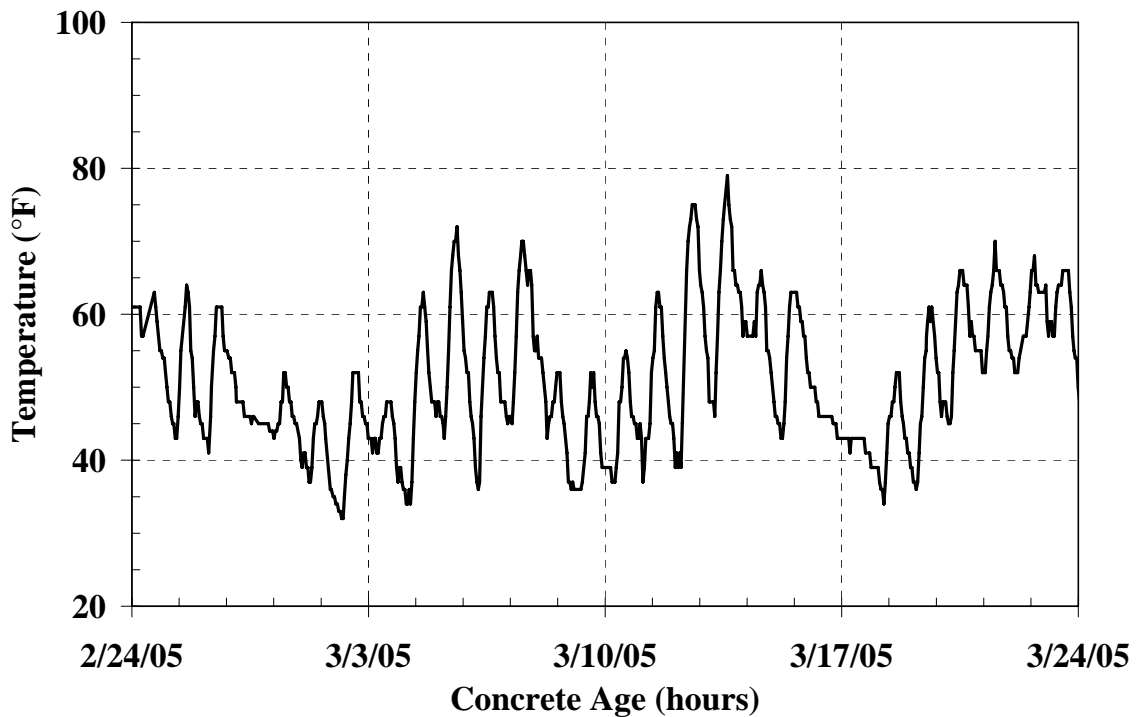

Figure C-2: Ambient temperatures of the cold-weather placement of mock bridge deck

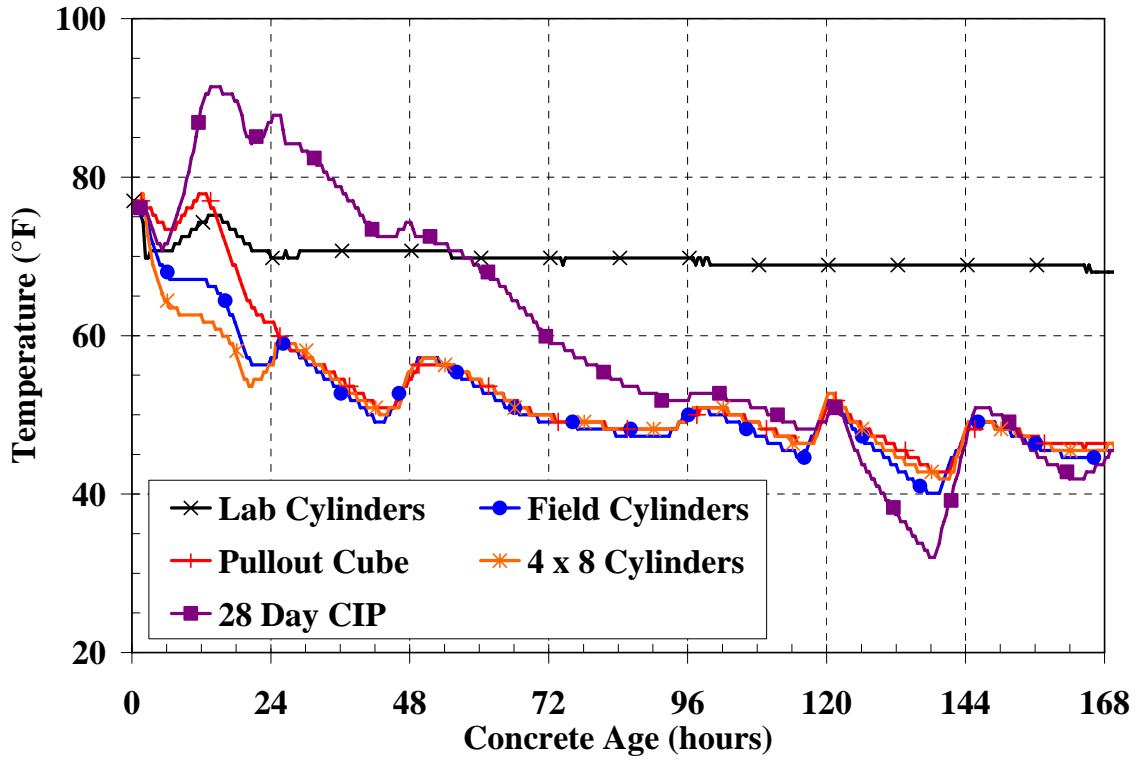

Figure C-3: Molded cylinder temperature history for cold-weather placement of mock bridge deck

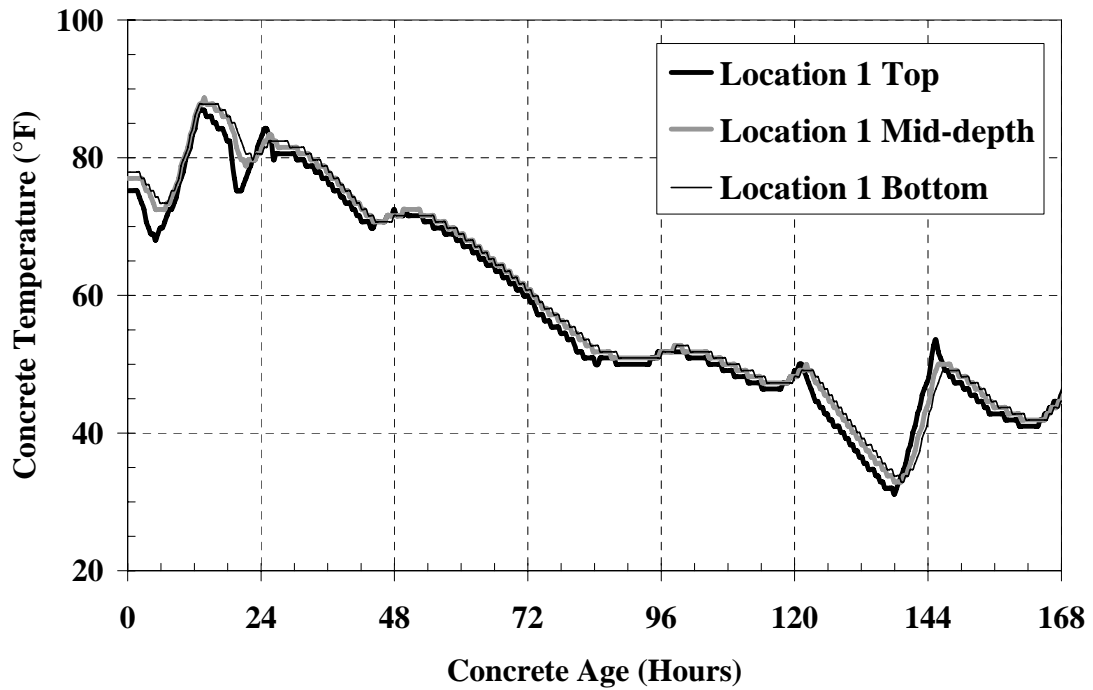

Figure C-4: Mock bridge deck temperatures Location 1 for cold-weather placement

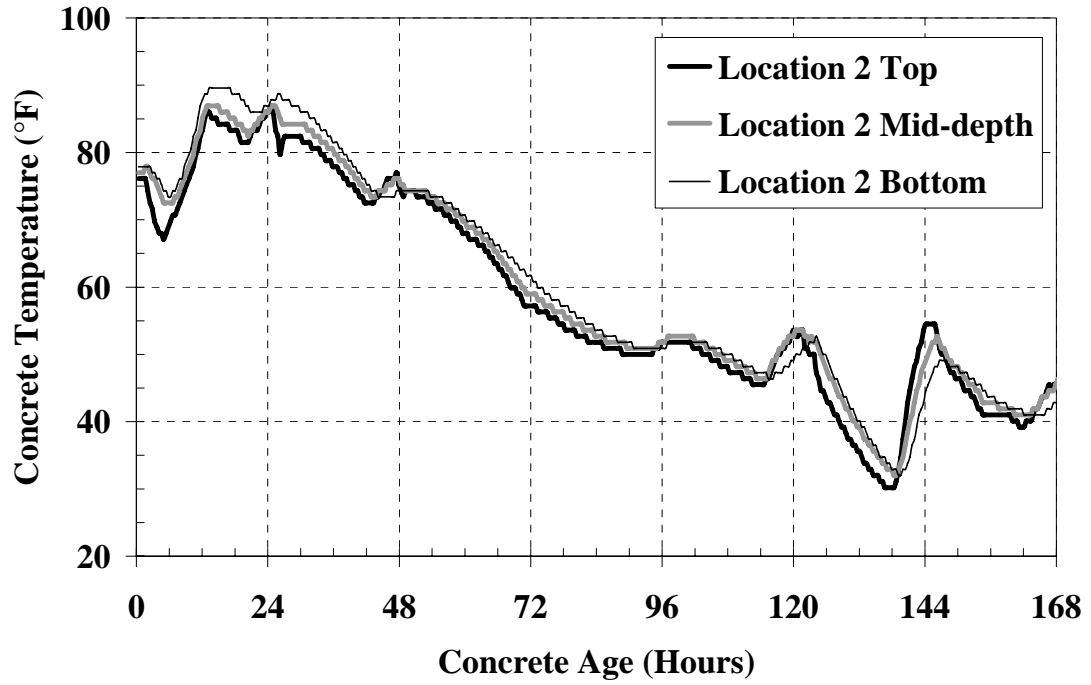

Figure C-5: Mock bridge deck temperatures Location 2 for cold-weather placement

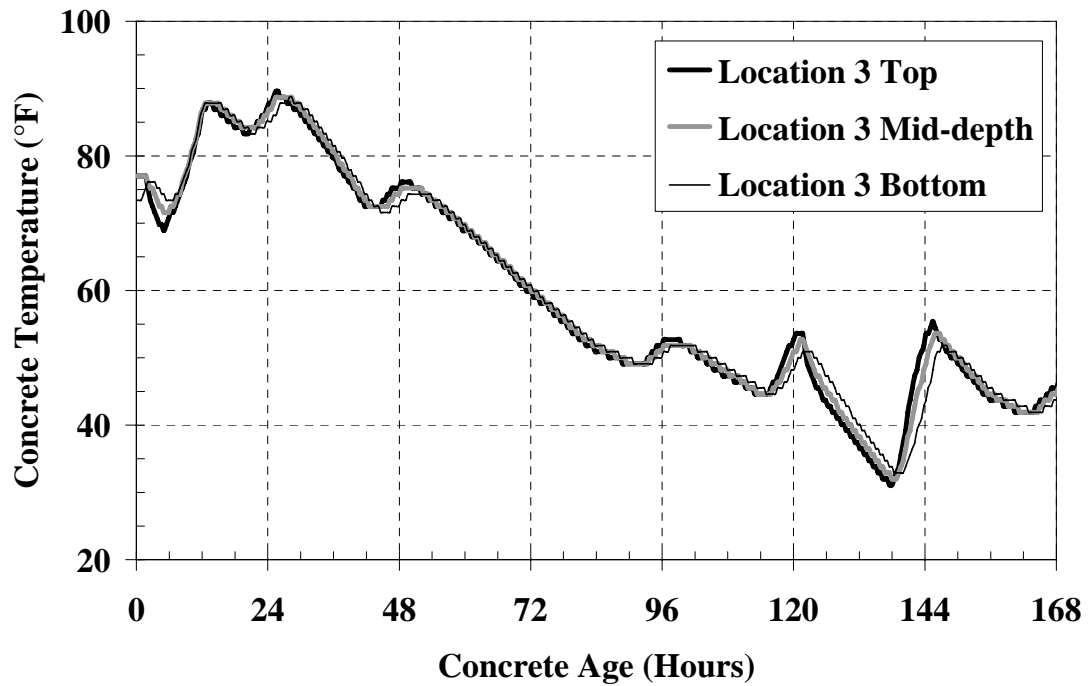

Figure C-6: Mock bridge deck temperatures Location 3 for cold-weather placement

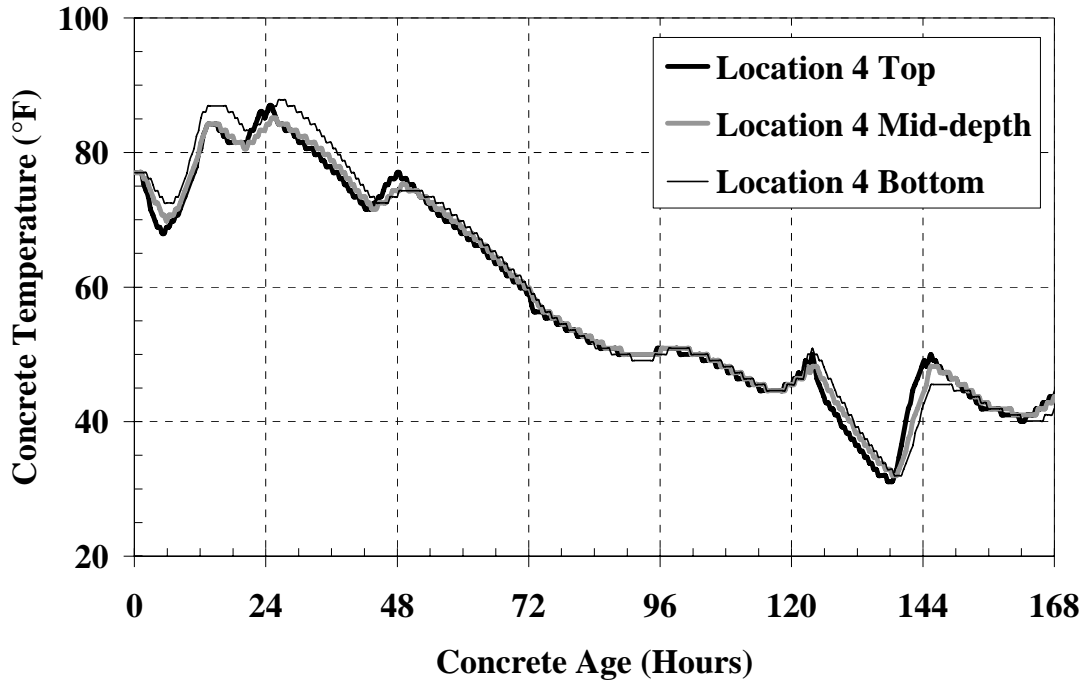

Figure C-7: Mock bridge deck temperatures Location 4 for cold-weather placement

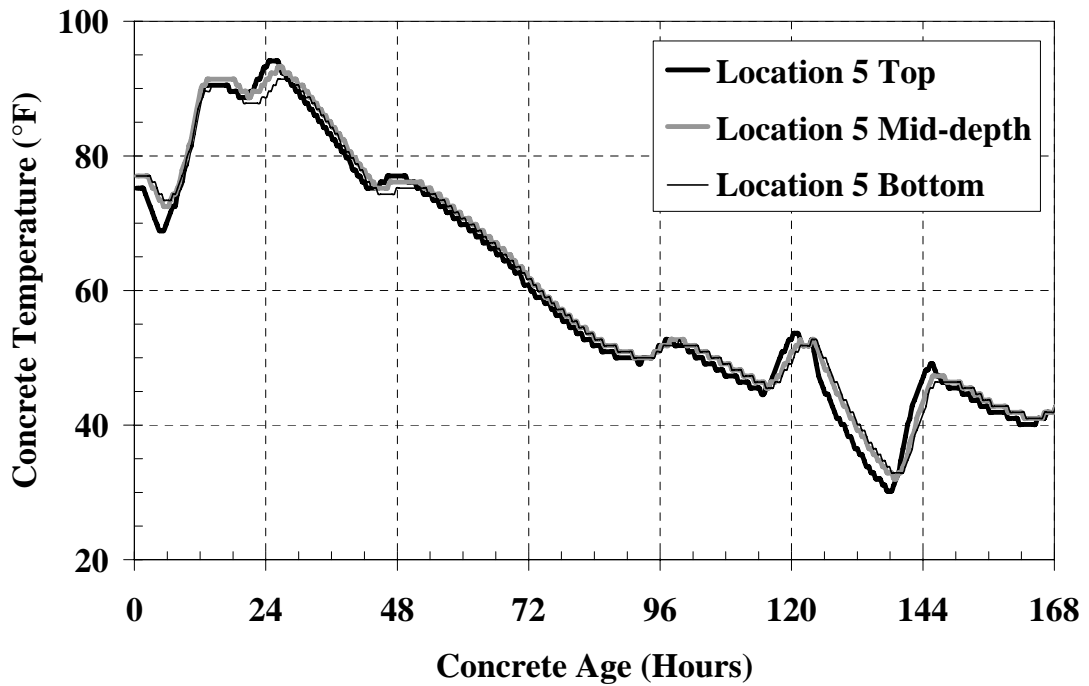

Figure C-8: Mock bridge deck temperatures Location 5 for cold-weather placement

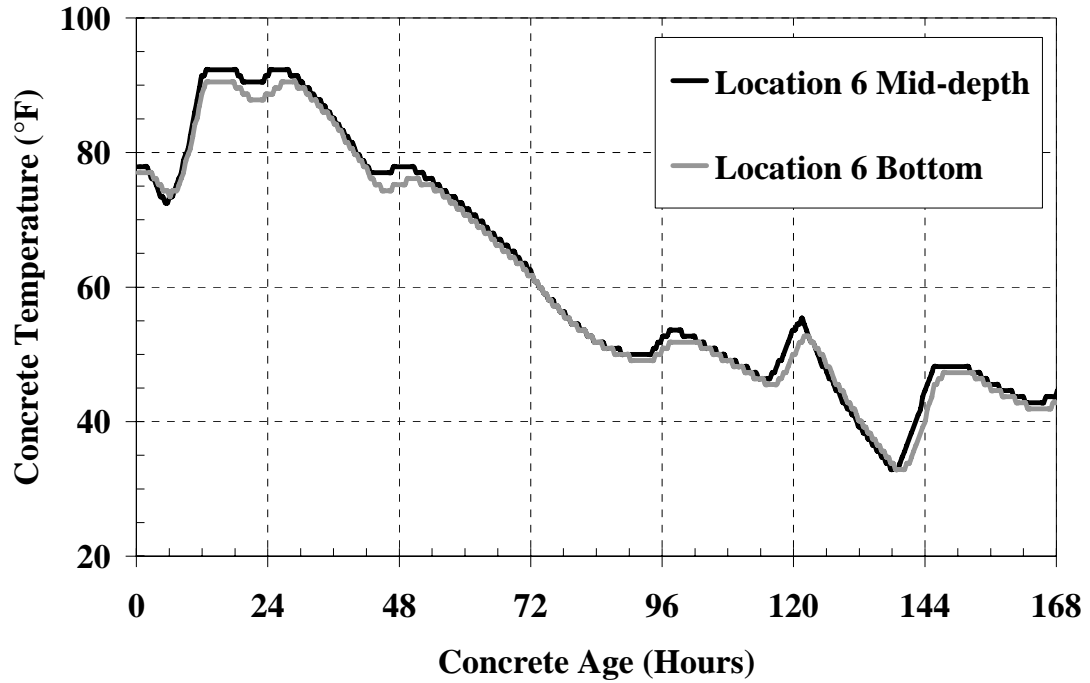

Figure C-9: Mock bridge deck temperatures Location 6 for cold-weather placement

The following tables and figures are the best-fit exponential function values for the strength-maturity relationships, the estimated cylinder and in-place strengths from the all maturity functions, and the *laboratory* and *water-tank* S-M relationships for the molded cylinders and in-place testing using the Nurse-Saul maturity function with $T_0 = -10\text{ }^\circ\text{C}$ and Arrhenius maturity function with $E = 40\text{ kJ/mol}$.

Table C-13: Strength-maturity relationship exponential function values for the cold-weather placement of mock bridge deck

Curing Condition	Exponential Value	Concrete Age	Nurse-Saul Function		Arrhenius Function	
			T _o = 0 °C	T _o = -10 °C	E = 33,500 J/mol	E = 40,000 J/mol
<i>Lab</i>	S _u (psi)	5,918	5,925	5,926	5,921	5,919
	β	0.6919	0.7116	0.7037	0.7126	0.7180
	τ	56.2770	1226.0859	1786.6118	53.7540	53.3231
	R ²	0.99	0.99	0.99	0.99	0.99
<i>Lime-Saturated Water Tank</i>	S _u (psi)	5,164	5,064	5,197	5,147	5,164
	β	1.1090	1.2813	1.0731	1.1325	1.1090
	τ	42.4103	867.4194	1499.0252	41.2044	42.4103
	R ²	0.99	0.98	0.98	0.98	0.98

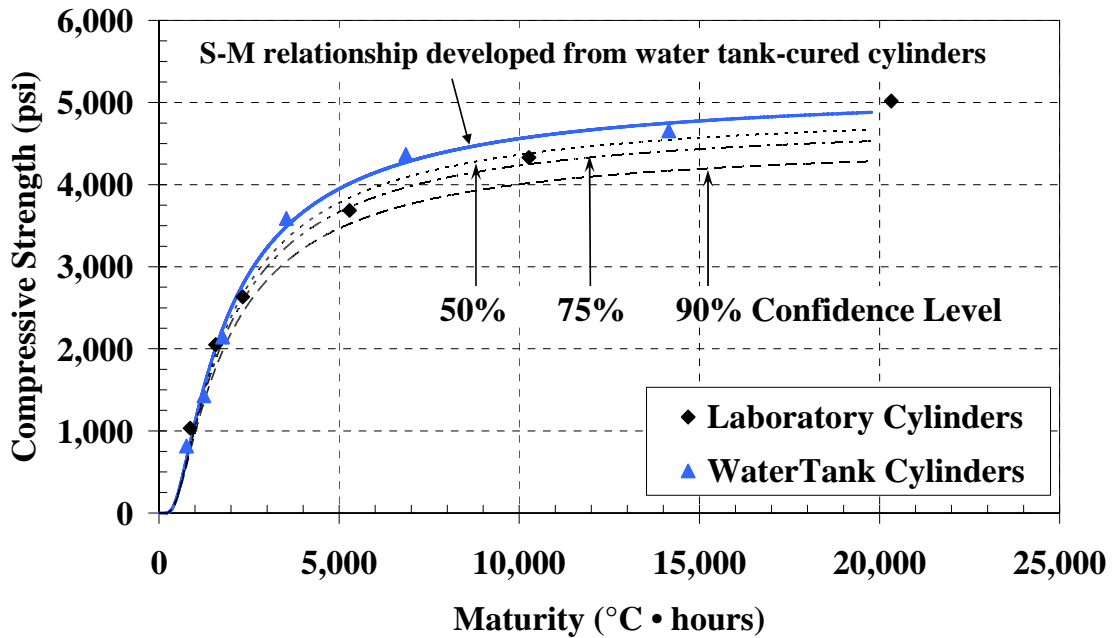

Figure C-10: Water-tank S-M relationship with confidence levels for the cold-weather placement of mock bridge deck (T_o = -10 °C)

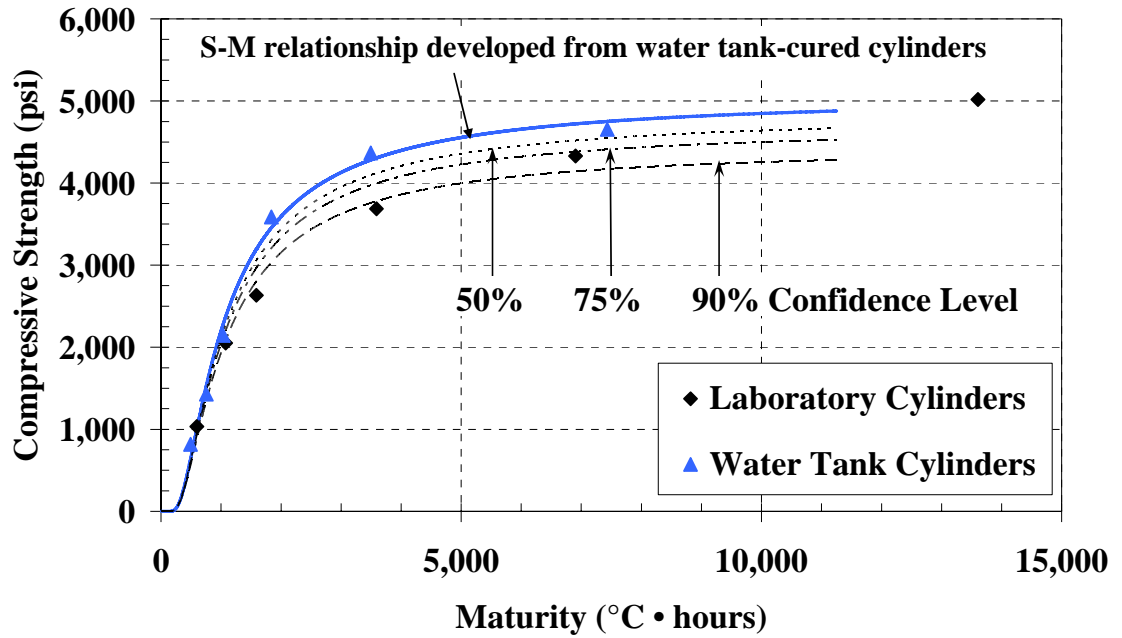

Figure C-11: *Water-tank S-M relationship with confidence levels for the cold-weather placement of mock bridge deck ($T_o = 0\text{ }^\circ\text{C}$)*

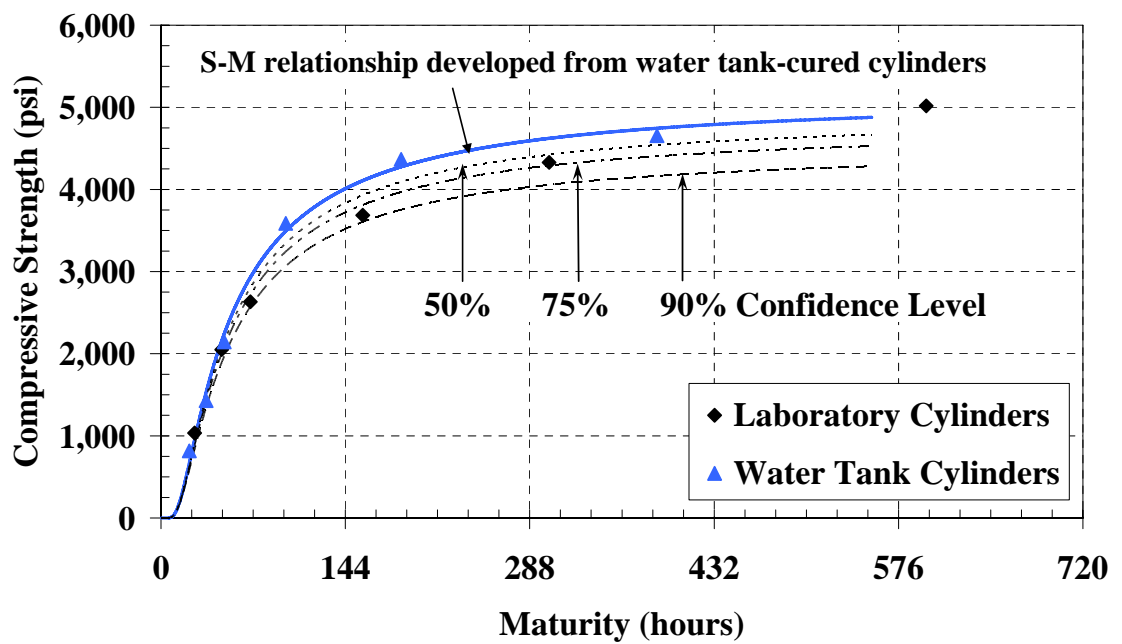

Figure C-12: *Water-tank S-M relationship with confidence levels for the cold-weather placement of mock bridge deck ($E = 33.5\text{ kJ/mol}$)*

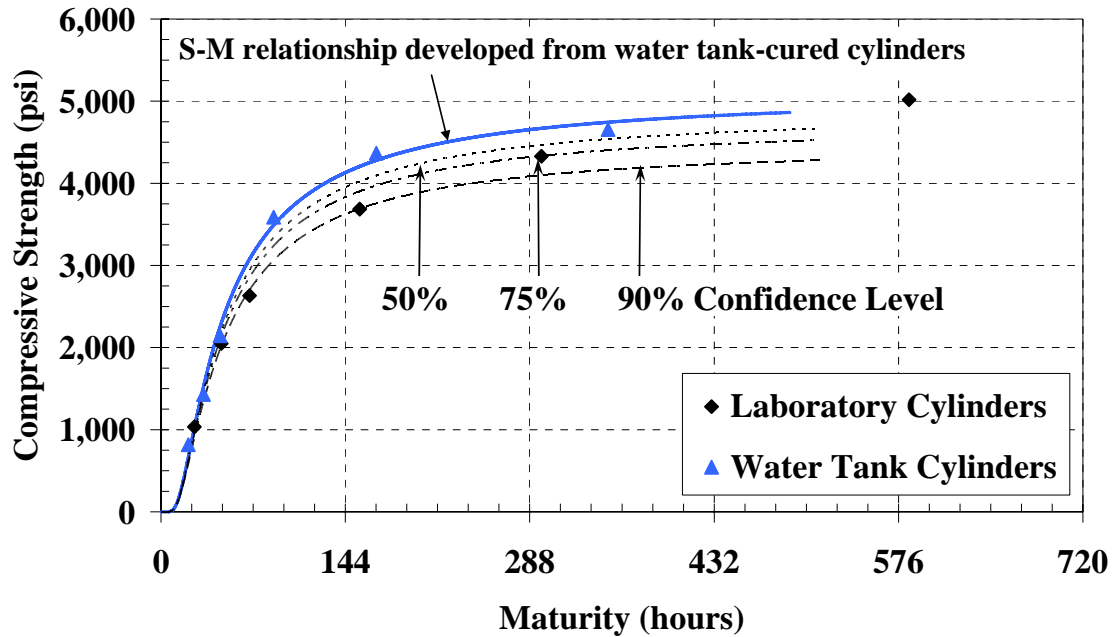

Figure C-13: Water-tank S-M relationship with confidence levels for the cold-weather placement of mock bridge deck ($E = 40 \text{ kJ/mol}$)

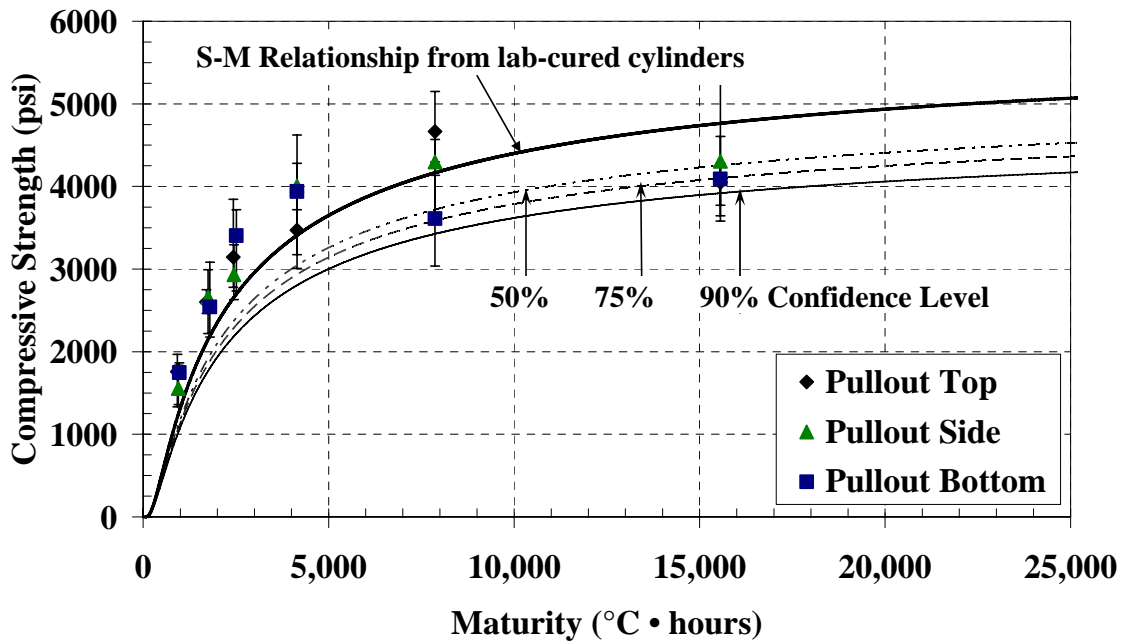

Figure C-14: Pullout test with *laboratory* S-M relationship and confidence levels for the cold-weather placement of the mock bridge deck ($T_0 = -10 \text{ }^{\circ}\text{C}$)

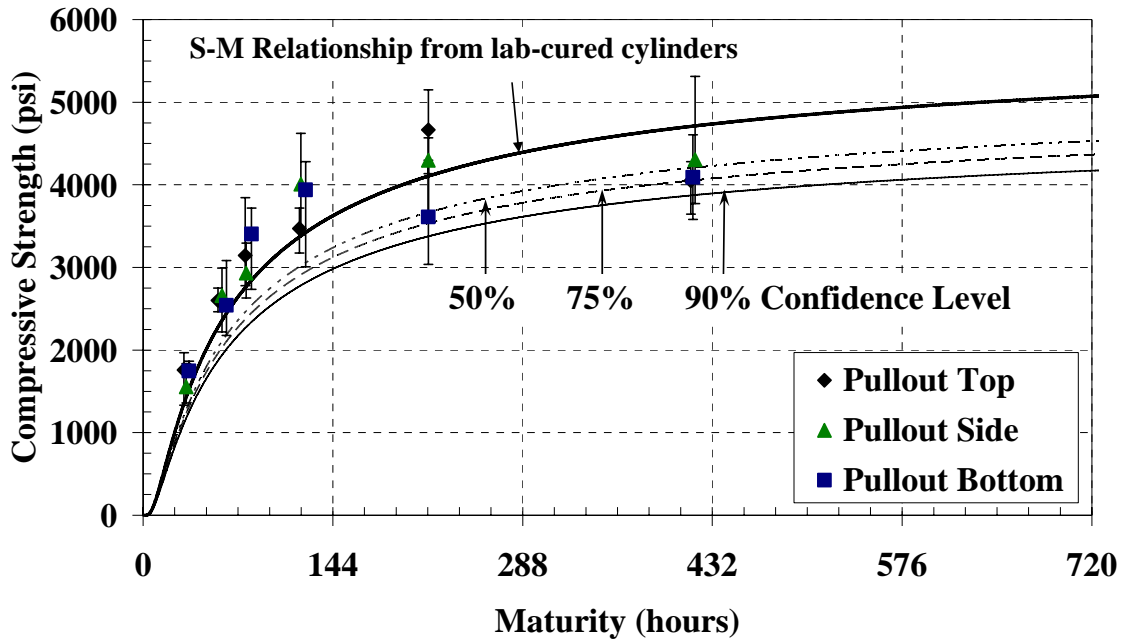

Figure C-15: Pullout test with *laboratory* S-M relationship and confidence levels for the cold-weather placement of the mock bridge deck ($E = 40 \text{ kJ/mol}$)

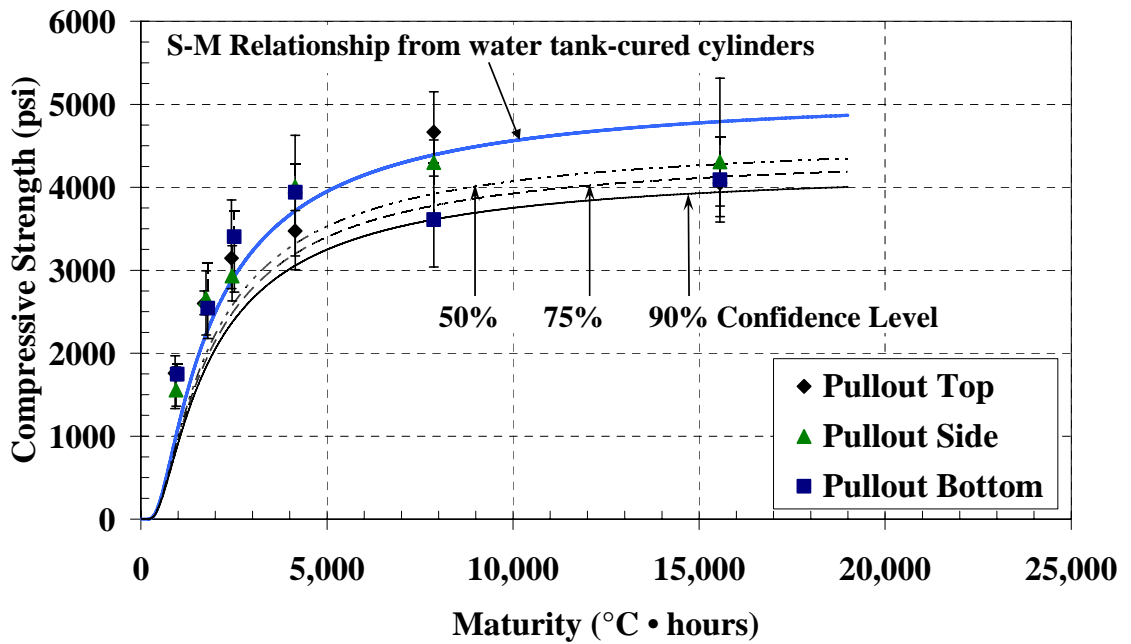

Figure C-16: Pullout test with *water-tank* S-M relationship and confidence levels for the cold-weather placement of mock bridge deck ($T_o = -10^{\circ}\text{C}$)

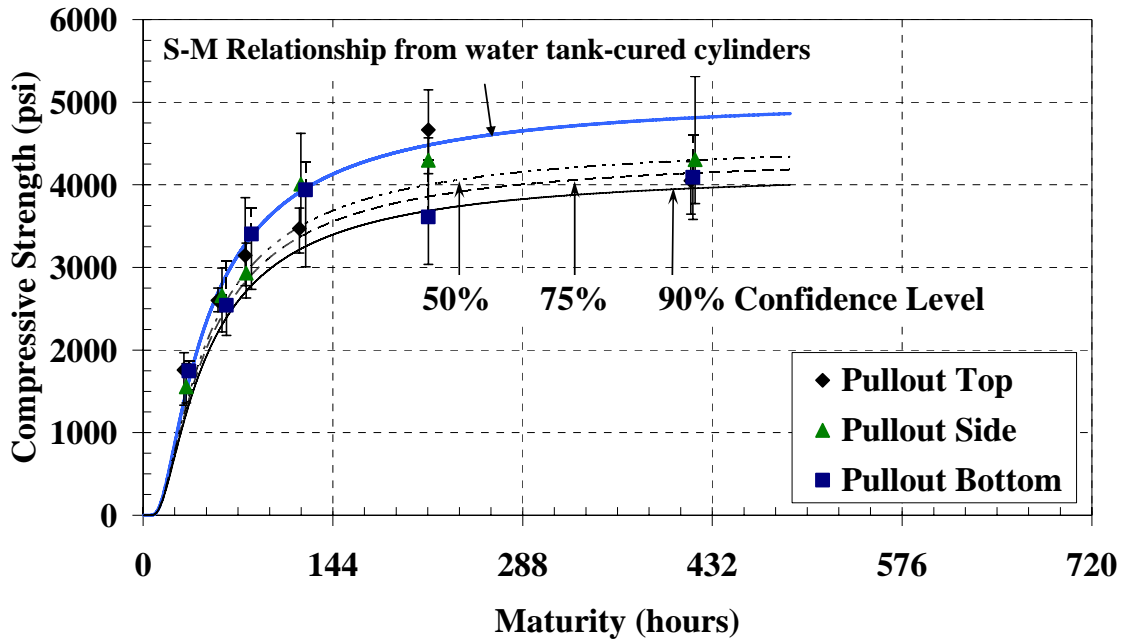

Figure C-17: Pullout test with *water-tank* S-M relationship and confidence levels for the cold-weather placement of mock bridge deck ($E = 40 \text{ kJ/mol}$)

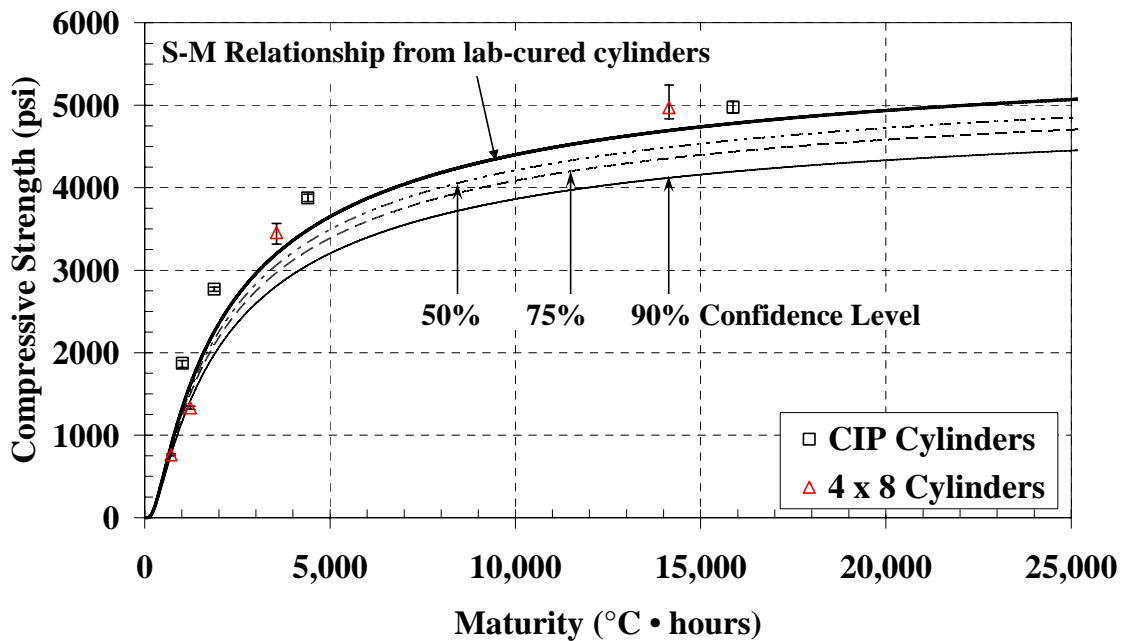

Figure C-18: Cast-in-place cylinders and 4x 8 inch cylinders with *laboratory* S-M relationship and confidence levels for the cold-weather placement of the mock bridge deck ($T_0 = -10 \text{ }^{\circ}\text{C}$)

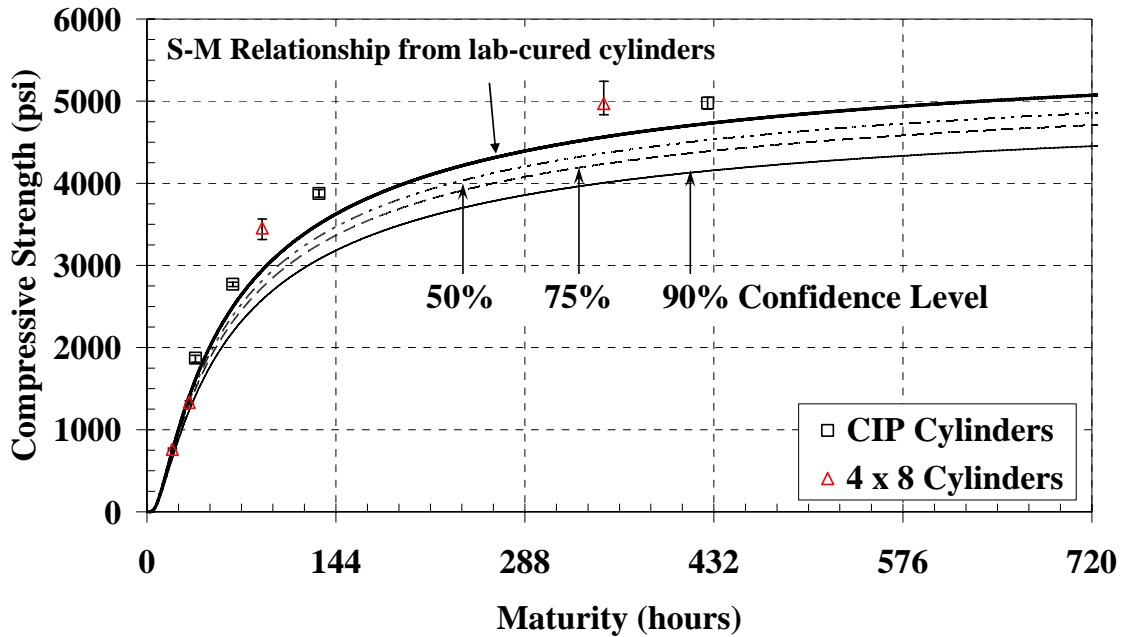

Figure C-19: Cast-in-place cylinders and 4 x 8 inch cylinders with *laboratory* S-M relationship and confidence levels for the cold-weather placement of the mock bridge deck ($E = 40 \text{ kJ/mol}$)

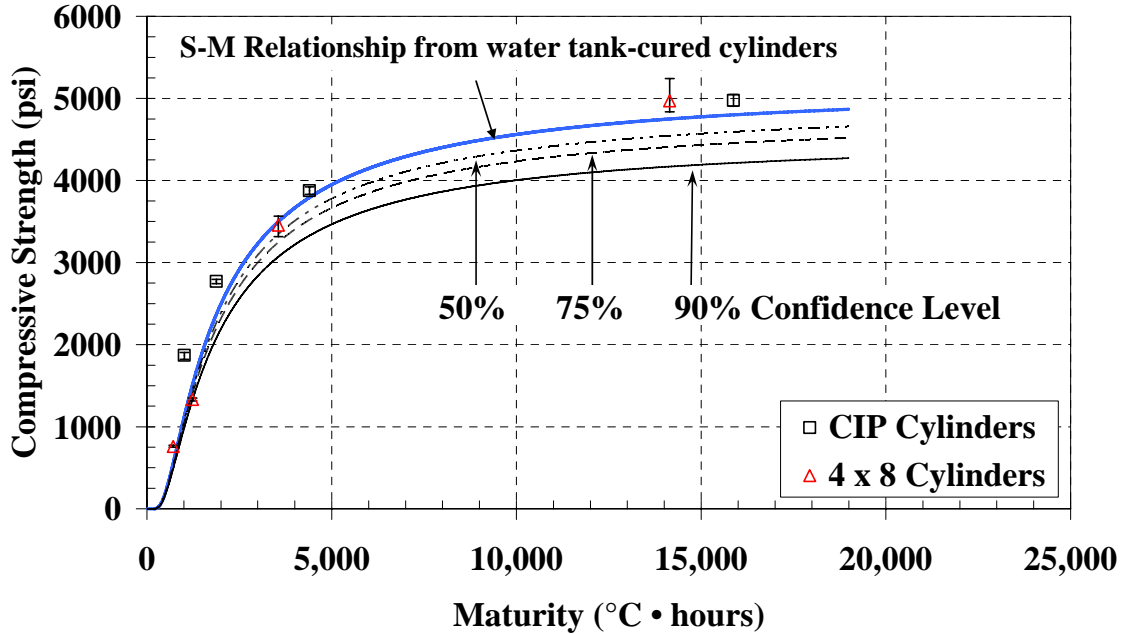

Figure C-20: Cast-in-place cylinders and 4 x 8 inch cylinders with *water-tank* S-M relationship and confidence levels for the cold-weather placement of mock bridge deck ($T_o = -10^{\circ}\text{C}$)

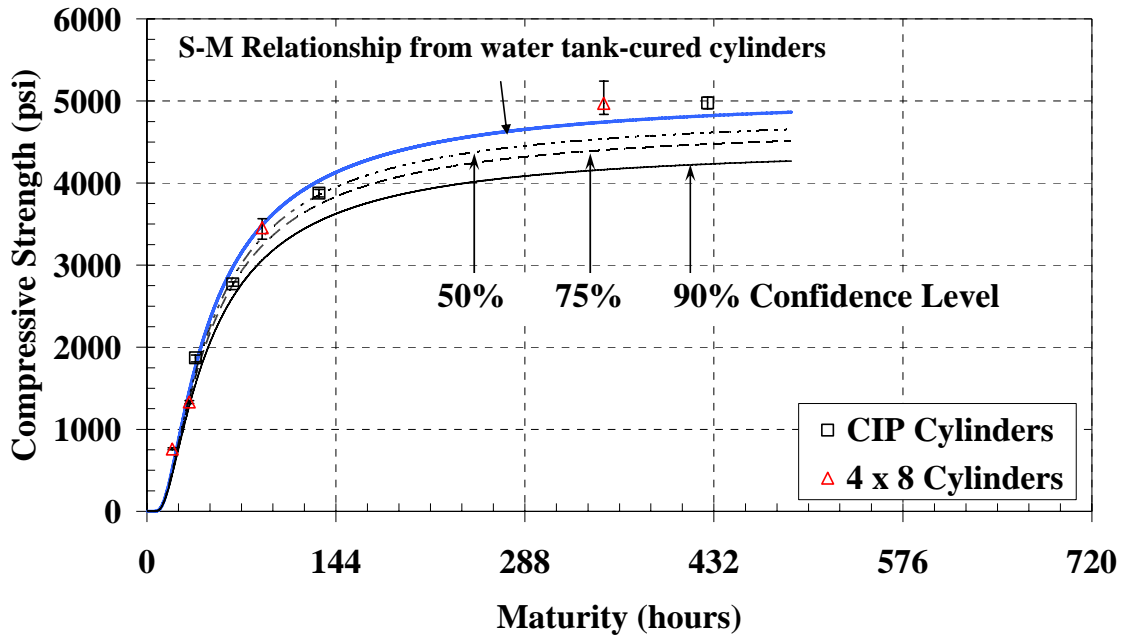

Figure C-21: Cast-in-place cylinders and 4 x 8 inch cylinders with *water-tank* S-M relationship and confidence levels for the cold-weather placement of mock bridge deck ($E = 40 \text{ kJ/mol}$)

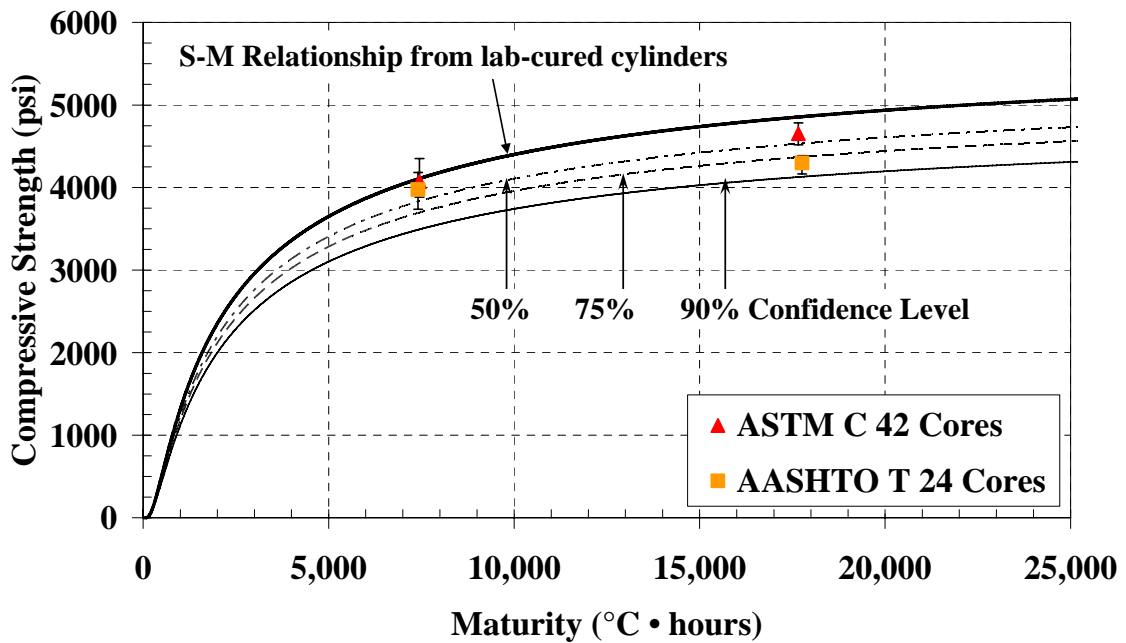

Figure C-22: Cores with *laboratory* S-M relationship and confidence levels for the cold-weather placement of the mock bridge deck ($T_0 = -10 \text{ }^{\circ}\text{C}$)

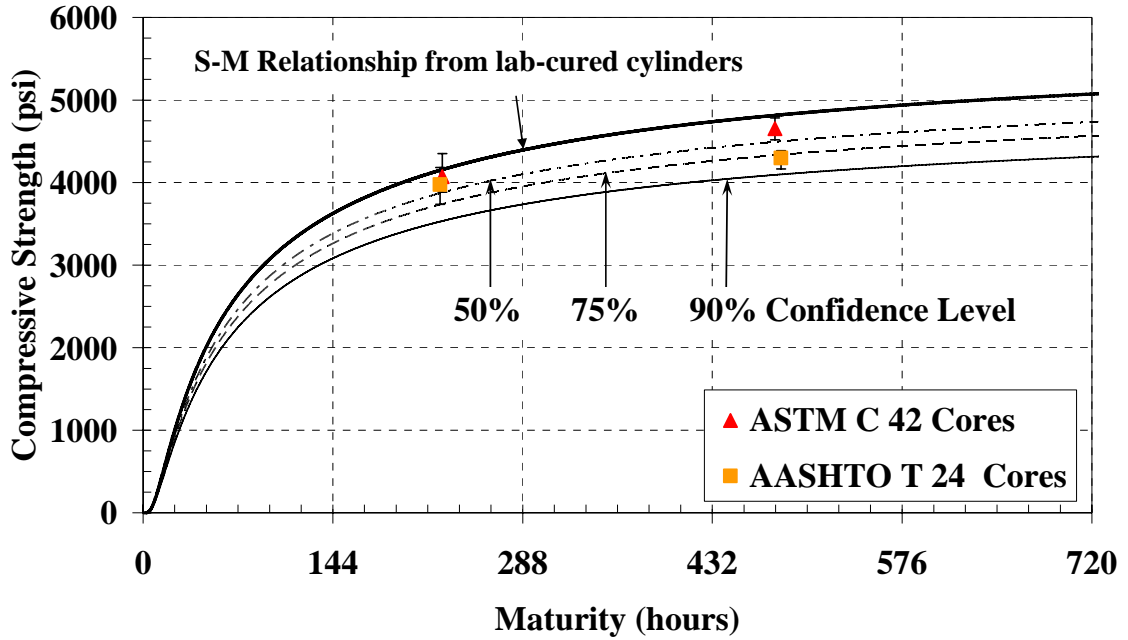

Figure C-23: Cores with *laboratory* S-M relationship and confidence levels for the cold-weather placement of the mock bridge deck ($E = 40 \text{ kJ/mol}$)

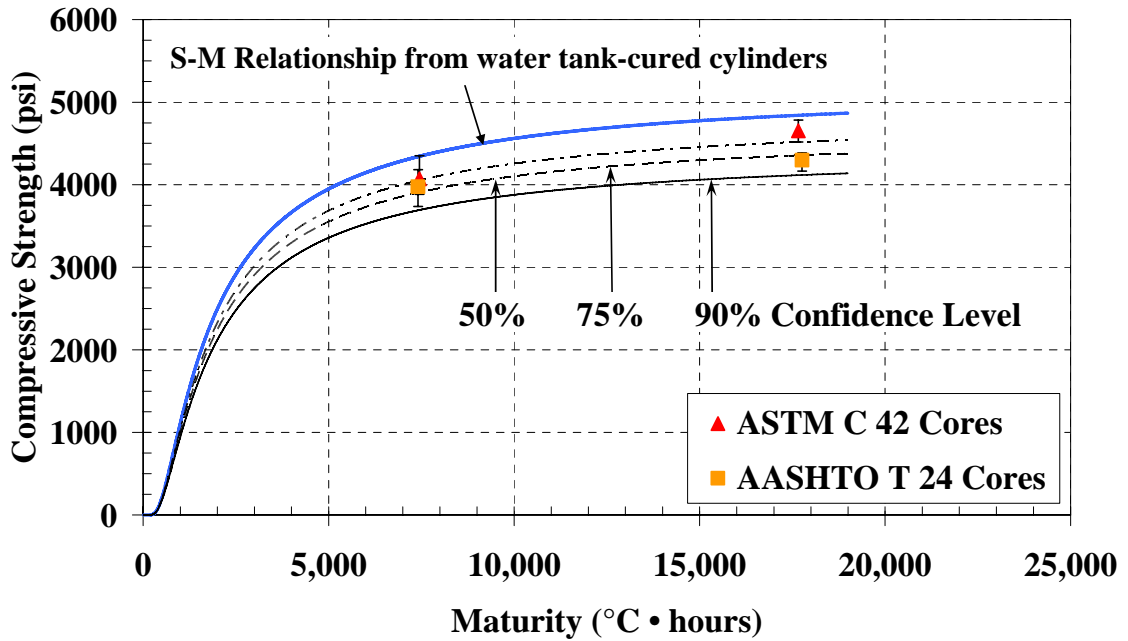

Figure C-24: Cores with *water-tank* S-M relationship and confidence levels for the cold-weather placement of mock bridge deck ($T_o = -10^{\circ}\text{C}$)

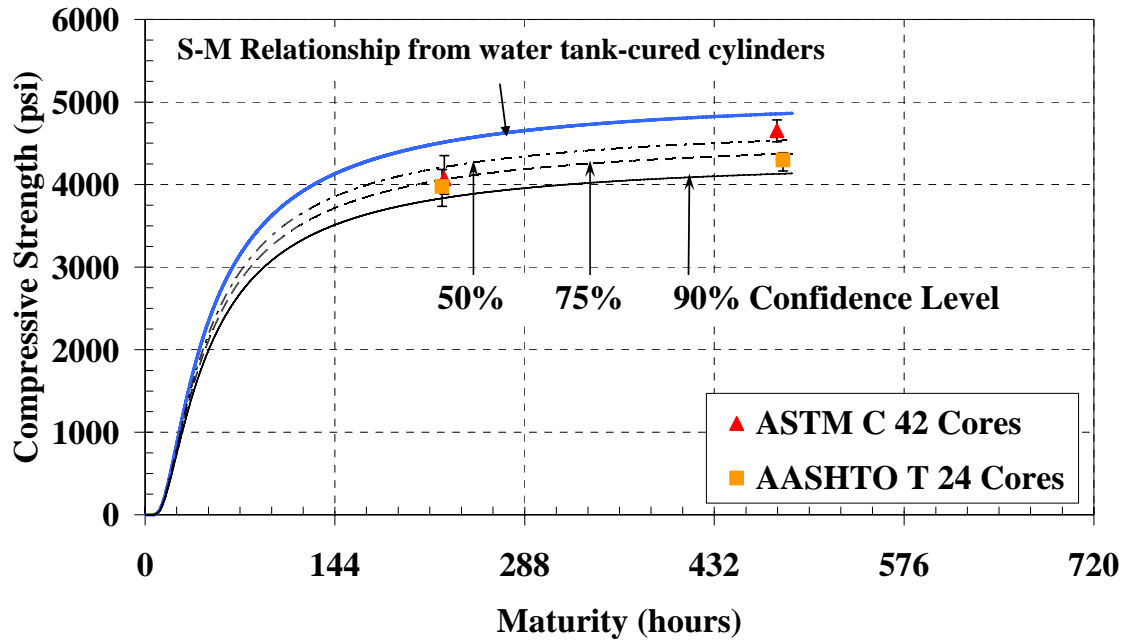

Figure C-25: Cores with *water-tank* S-M relationship and confidence levels for the cold-weather placement of mock bridge deck ($E = 40$ kJ/mol)

Table C-14: Estimated strengths using *laboratory* cylinders S-M relationship for the cold-weather placement of mock bridge deck (psi)

	Concrete Age (hours)	Measured Strength (psi)	Nurse-Saul Function		Arrhenius Function	
			$T_o = -10$ °C	$T_o = 0$ °C	$E = 40$ kJ/mol	$E = 33.5$ kJ/mol
<i>Lab Cylinders</i>	26.8	1,030	1,110	1,110	1,110	1,110
	49.4	2,050	1,980	1,980	1,980	1,980
	73.6	2,630	2,580	2,580	2,580	2,580
	170.3	3,690	3,720	3,720	3,720	3,720
	336.9	4,330	4,430	4,420	4,420	4,420
	672.4	5,020	4,950	4,950	4,950	4,950
<i>Water Tank Cylinder</i>	27.0	820	960	870	850	900
	49.2	1,430	1,630	1,440	1,450	1,530
	73.4	2,140	2,160	1,920	1,950	2,050
	170.2	3,590	3,190	2,800	2,950	3,080
	335.9	4,370	4,020	3,690	3,820	3,930
	672.3	4,650	4,690	4,490	4,570	4,640

Table C-15: Estimated strengths using *water-tank* cylinders S-M relationship for the cold-weather placement of mock bridge deck (psi)

	Concrete Age (hours)	Measured Strength (psi)	Nurse-Saul Function		Arrhenius Function	
			T _o = -10 °C	T _o = 0 °C	E = 40 kJ/mol	E = 33.5 kJ/mol
<i>Lab Cylinders</i>	26.8	1,030	850	1,000	1,030	950
	49.4	2,050	2,010	2,380	2,300	2,150
	73.6	2,630	2,780	3,200	3,080	2,930
	170.3	3,690	4,010	4,310	4,210	4,110
	336.9	4,330	4,580	4,720	4,670	4,620
	672.4	5,020	4,890	4,920	4,910	4,900
<i>Water Tank Cylinder</i>	27.0	820	660	640	660	660
	49.2	1,430	1,530	1,530	1,530	1,530
	73.4	2,140	2,250	2,290	2,250	2,250
	170.2	3,590	3,490	3,460	3,490	3,490
	335.9	4,370	4,270	4,280	4,280	4,280
	672.3	4,650	4,750	4,750	4,740	4,750

Table C-16: 4 x 8 inch cylinder test estimated strength using *laboratory* S-M relationship for the cold-weather placement of mock bridge deck (psi)

Concrete Age (Days)	Measured Strength (psi)	Nurse-Saul Function		Arrhenius Function	
		T _o = -10 °C	T _o = 0 °C	E = 40 kJ/mol	E = 33.5 kJ/mol
1.1	760	870	760	740	800
2.1	1,330	1,620	1,400	1,410	1,500
7.1	3,460	3,200	2,810	2,940	3,080
28.0	4,970	4,690	4,490	4,560	4,630

Table C-17: 4 x 8 inch cylinder test estimated strength using *water-tank* S-M relationship for the cold-weather placement of mock bridge deck (psi)

Concrete Age (Days)	Measured Strength (psi)	Nurse-Saul Function		Arrhenius Function	
		T _o = -10 °C	T _o = 0 °C	E = 40 kJ/mol	E = 33.5 kJ/mol
1.1	760	560	480	510	540
2.1	1,330	1,510	1,460	1,460	1,480
7.1	3,460	3,500	3,470	3,490	3,490
28.0	4,970	4,750	4,750	4,740	4,740

Table C-18: Cast-in-place cylinder test estimated strength using *laboratory* S-M relationship for the cold-weather placement of mock bridge deck (psi)

Concrete Age (Days)	Measured Strength (psi)	Nurse-Saul Function		Arrhenius Function	
		T _o = -10 °C	T _o = 0 °C	E = 40 kJ/mol	E = 33.5 kJ/mol
1.1	1,870	1,340	1,440	1,610	1,510
2.1	2,770	2,250	2,350	2,500	2,410
7.1	3,880	3,490	3,350	3,500	3,520
28.0	4,980	4,780	4,660	4,730	4,760

Table C-19: Cast-in-place cylinder test estimated strength using *water-tank* S-M relationship for the cold-weather placement of mock bridge deck (psi)

Concrete Age (Days)	Measured Strength (psi)	Nurse-Saul Function		Arrhenius Function	
		T _o = -10 °C	T _o = 0 °C	E = 40 kJ/mol	E = 33.5 kJ/mol
1.1	1,870	1,130	1,530	1,760	1,510
2.1	2,770	2,370	2,900	2,970	2,720
7.1	3,880	3,790	4,010	4,030	3,930
28.0	4,980	4,800	4,820	4,820	4,810

Table C-20: Core test estimated strength using *laboratory* S-M relationship for the cold-weather placement of mock bridge deck (psi)

Concrete Age (Days)	Curing Method	Measured Strength (psi)	Nurse-Saul Function		Arrhenius Function	
			T _o = -10 °C	T _o = 0 °C	E = 40 kJ/mol	E = 33.5 kJ/mol
10.2	ASTM C 42	4,070	4,110	4,100	4,160	4,140
	AASHTO T 24	3,980	4,100	4,090	4,150	4,140
30.0	ASTM C 42	4,650	4,850	4,760	4,810	4,840
	AASHTO T 24	4,300	4,860	4,770	4,820	4,840

Table C-21: Core test estimated strength using *water-tank* S-M relationship for the cold-weather placement of mock bridge deck (psi)

Concrete Age (Days)	Curing Method	Measured Strength (psi)	Nurse-Saul Function		Arrhenius Function	
			T _o = -10 °C	T _o = 0 °C	E = 40 kJ/mol	E = 33.5 kJ/mol
10.2	ASTM C 42	4,070	4,340	4,560	4,510	4,440
	AASHTO T 24	3,980	4,340	4,550	4,510	4,430
30.0	ASTM C 42	4,650	4,840	4,860	4,860	4,850
	AASHTO T 24	4,300	4,840	4,860	4,860	4,850

Table C-22: Pullout cube estimated strength from *water-tank* S-M relationship for the cold-weather placement of mock bridge deck (psi)

Concrete Age (hours)	Nurse-Saul Function		Arrhenius Function		Measured Strength (psi)
	T _o = -10 °C	T _o = 0 °C	E = 33.5 kJ/mol	E = 40 kJ/mol	
26.2	790	920	890	960	1,130
48.5	1,660	1,800	1,730	1,790	1,630
157.6	3,460	3,500	3,480	3,500	3,130

Table C-23: Mock bridge deck estimated pullout strength using *laboratory* S-M relationship for the cold-weather placement (psi)

Concrete Age (hours)	Insert Location	Measured Strength (psi)	Nurse-Saul Function		Arrhenius Function	
			T _o = -10 °C	T _o = 0 °C	E = 40 kJ/mol	E = 33.5 kJ/mol
25.7	Top	1,760	1,200	1,260	1,350	1,300
	Side	1,560	1,240	1,320	1,430	1,360
	Bottom	1,750	1,280	1,380	1,520	1,440
47.7	Top	2,600	2,110	2,180	2,270	2,210
	Side	2,660	2,150	2,240	2,360	2,280
	Bottom	2,540	2,190	2,300	2,440	2,350
72.2	Top	3,140	2,650	2,690	2,750	2,720
	Side	2,930	2,660	2,710	2,770	2,730
	Bottom	3,400	2,700	2,760	2,850	2,790
168.8	Top	3,470	3,410	3,220	3,370	3,410
	Side	4,010	3,410	3,220	3,380	3,420
	Bottom	3,940	3,410	3,220	3,420	3,450
335.1	Top	4,660	4,170	3,990	4,110	4,150
	Side	4,300	4,170	3,990	4,110	4,150
	Bottom	3,610	4,170	3,990	4,110	4,150
671.2	Top	4,050	4,760	4,640	4,710	4,740
	Side	4,300	4,760	4,640	4,710	4,750
	Bottom	4,090	4,760	4,640	4,710	4,750

Table C-24: Mock bridge deck estimated pullout strength using *water-tank* S-M relationship for the cold-weather placement (psi)

Concrete Age (hours)	Insert Location	Measured Strength (psi)	Nurse-Saul Function		Arrhenius Function	
			T _o = -10 °C	T _o = 0 °C	E = 40 kJ/mol	E = 33.5 kJ/mol
25.7	Top	1,760	960	1,240	1,380	1,200
	Side	1,560	1,010	1,330	1,500	1,290
	Bottom	1,750	1,070	1,430	1,640	1,400
47.7	Top	2,600	2,170	2,670	2,690	2,460
	Side	2,660	2,230	2,750	2,800	2,550
	Bottom	2,540	2,280	2,830	2,910	2,650
72.2	Top	3,140	2,870	3,330	3,280	3,090
	Side	2,930	2,880	3,350	3,300	3,110
	Bottom	3,400	2,920	3,410	3,380	3,180
168.8	Top	3,470	3,720	3,890	3,910	3,820
	Side	4,010	3,720	3,890	3,920	3,830
	Bottom	3,940	3,720	3,890	3,960	3,860
335.1	Top	4,660	4,390	4,490	4,480	4,440
	Side	4,300	4,390	4,490	4,480	4,440
	Bottom	3,610	4,390	4,490	4,480	4,440
671.2	Top	4,050	4,790	4,810	4,810	4,800
	Side	4,300	4,790	4,810	4,810	4,810
	Bottom	4,090	4,790	4,810	4,810	4,800

C.2 WARM-WEATHER PLACEMENT OF MOCK BRIDGE DECK RESULTS

Table C-25: *Laboratory-cured cylinder strength data for warm-weather placement of mock bridge deck*

Intended Age (days)	Actual Time Tested	Concrete Age (hours)	Compressive Strength (psi)	% Range
1	6/15/05 3:05 PM	25.6	2,040	3.4
			2,050	
			1,980	
2	6/16/05 3:45 PM	50.3	3,070	2.8
			3,010	
			2,990	
3	6/17/05 1:50 PM	72.3	3,410	3.6
			3,290	
			3,290	
7	6/21/05 3:35 PM	170.1	3,980	3.8
			4,130	
			4,000	
14	6/28/05 1:35 PM	336.1	5,050	4.0
			4,950	
			4,850	
28	7/12/05 3:40 PM	674.2	6,020	9.6
			6,230	
			5,660	

Table C-26: *Water-tank-cured cylinder strength data for warm-weather placement of mock bridge deck*

Intended Age (days)	Actual Time Tested	Concrete Age (hours)	Compressive Strength (psi)	% Range
1	6/15/05 2:55 PM	25.4	1,960	0.1
			*	
			1,960	
2	6/16/05 2:33 PM	49.0	2,820	5.2
			2,900	
			2,760	
3	6/17/05 1:40 PM	72.2	3,130	2.9
			3,060	
			3,040	
7	6/21/05 3:20 PM	169.8	3,980	2.3
			3,990	
			4,080	
14	6/28/05 1:25 PM	335.9	4,720	4.1
			4,860	
			4,670	
28	7/12/05 3:20 PM	673.8	5,690	3.1
			5,570	
			5,510	

* Indicates cylinder data removed due to outliers

Table C-27: Lime-saturated water-tank-cured 4 x 8 inch strength data for warm-weather placement of mock bridge deck

Intended Age (days)	Actual Time Tested	Concrete Age (hours)	Compressive Strength (psi)	% Range
1	6/15/05 2:45 PM	25.3	*	4.2
			1,990	
			2,070	
2	6/16/05 2:15 PM	48.8	2,940	6.6
			2,840	
			2,760	
7	6/21/05 3:10 PM	169.7	4,250	5.4
			4,120	
			4,350	
28	7/12/05 3:20 PM	673.8	5,930	1.9
			6,040	
			*	

* Indicates 4 x 8 test removed due to outliers

Table C-28: Cast-in-place strength data for warm-weather placement of mock bridge deck

Intended Age (days)	Actual Time Tested	Concrete Age (hours)	Compressive Strength (psi)	% Range
1	6/15/05 2:35 PM	25.1	2,980	5.2
			*	
			2,830	
2	6/16/05 2:25 PM	48.9	3,730	4.0
			3,590	
			3,580	
7	6/21/05 3:00 PM	169.5	4,590	6.6
			4,300	
			4,320	
28	7/12/05 3:40 PM	674.2	4,920	4.1
			4,730	
			4,730	

* Indicates CIP test removed due to outliers

Table C-29: Top pullout strength data for warm-weather placement of mock bridge deck

Intended Age (days)	Actual Time Tested	Concrete Age (hours)	Pullout Load (kN)	Compressive Strength (psi)	% Range
1	6/15/05 1:28 PM	24.0	21.2	3,080	23.5
			20.0	2,900	
			18.2	2,630	
			22.9	3,340	
			21.6	3,140	
2	6/16/05 1:55 PM	48.4	22.9	3,340	14.2
			20.0	2,900	
			20.2	2,930	
			21.8	3,170	
			-	-	
3	6/17/05 1:00 PM	71.5	22.9	3,340	17.5
			22.4	3,260	
			25.8	3,810	
			22.0	3,200	
			24.8	3,630	
7	6/21/05 2:00 PM	168.5	25.8	3,810	22.2
			22.4	*	
			31.0	4,750	
			27.9	4,190	
			18.5	*	
14	6/28/05 1:00 PM	335.5	44.3	*	27.9
			35.5	5,560	
			28.0	4,210	
			32.9	5,100	
			30.0	4,570	
28	7/12/05 1:50 PM	672.3	42.7	6,830	19.0
			39.8	6,310	
			36.0	5,650	
			38.2	6,040	
			16.8	*	

* Indicates pullout test removed due to outliers

- Indicates no pullout data due to failure to conduct test on pullout mock bridge deck

Table C-30: Side pullout strength data for warm-weather placement of mock bridge deck

Intended Age (days)	Actual Time Tested	Concrete Age (hours)	Pullout Load (kN)	Compressive Strength (psi)	% Range
1	6/15/05 1:28 PM	24.0	18.5	2,680	12.2
			19.0	2,750	
			17.3	2,490	
			18.0	2,600	
			16.9	2,430	
2	6/16/05 1:55 PM	48.4	17.2	*	18.0
			25.2	3,700	
			23.3	3,400	
			21.2	3,080	
			24.3	3,550	
3	6/17/05 1:00 PM	71.5	23.3	3,400	26.7
			31.3	*	
			25.9	3,830	
			20.1	2,920	
			24.1	3,520	
7	6/21/05 2:00 PM	168.5	25.1	3,680	18.1
			27.1	4,040	
			20.0	*	
			25.6	3,770	
			23.1	3,370	
14	6/28/05 1:00 PM	335.5	28.7	4,330	8.5
			26.9	4,010	
			28.4	4,280	
			28.9	4,370	
			20.5	*	
28	7/12/05 1:50 PM	672.3	-	-	-
			-	-	
			-	-	
			-	-	
			-	-	

* Indicates pullout test removed due to outliers

- Indicates no pullout data due to failure to conduct test on pullout mock bridge deck

Table C-31: Bottom pullout strength data for warm-weather placement of mock bridge deck

Intended Age (days)	Actual Time Tested	Concrete Age (hours)	Pullout Load (kN)	Compressive Strength (psi)	% Range
1	6/15/05 1:28 PM	24.0	20.3	2,950	11.8
			35.7	*	
			27.9	*	
			22.7	3,310	
			20.3	2,950	
2	6/16/05 1:55 PM	48.4	24.8	3,630	15.7
			21.3	3,100	
			28.9	*	
			24.1	3,520	
			22.1	3,220	
3	6/17/05 1:00 PM	71.5	34.9	*	4.8
			40.4	*	
			24.1	3,520	
			23.4	3,420	
			23.0	3,360	
7	6/21/05 2:00 PM	168.5	29.2	4,430	34.8
			23.1	3,370	
			28.9	4,370	
			21.3	3,100	
			-	-	
14	6/28/05 1:00 PM	335.5	32.1	4,950	13.8
			36.2	5,690	
			-	-	
			-	-	
			-	-	
28	7/12/05 1:50 PM	672.3	34.3	5,350	15.9
			34.6	5,400	
			31.4	4,820	
			36.1	5,670	
			-	-	

* Indicates pullout test removed due to outliers

- Indicates no pullout data due to failure to conduct test on pullout mock bridge deck

Table C-32: Pullout cube strength data for warm-weather placement of mock bridge deck

Intended Age (days)	Actual Time Tested	Concrete Age (hours)	Pullout Load (kN)	Compressive Strength (psi)	% Range
1	6/15/05 1:50 PM	24.3	15.3	2,190	17.2
			14.3	2,040	
			15.9	2,280	
			-	-	
			13.7	1,950	
			15.1	2,160	
			15.5	2,220	
			16.2	2,330	
2	6/16/05 2:00 PM	48.5	17.5	2,520	29.4
			16.3	2,340	
			18.0	2,600	
			17.5	2,520	
			21.4	3,110	
			16.6	2,390	
			21.1	3,070	
			16.9	2,430	
7	6/21/05 2:20 PM	168.8	25.8	3,810	27.7
			27.1	4,040	
			26.5	3,940	
			26.6	3,950	
			22.9	3,340	
			22.5	3,280	
			20.9	3,040	
			25.0	3,660	

- Indicates no pullout data due to failure to conduct test on pullout cube

Figure C-26: Top of mock bridge deck core numbering

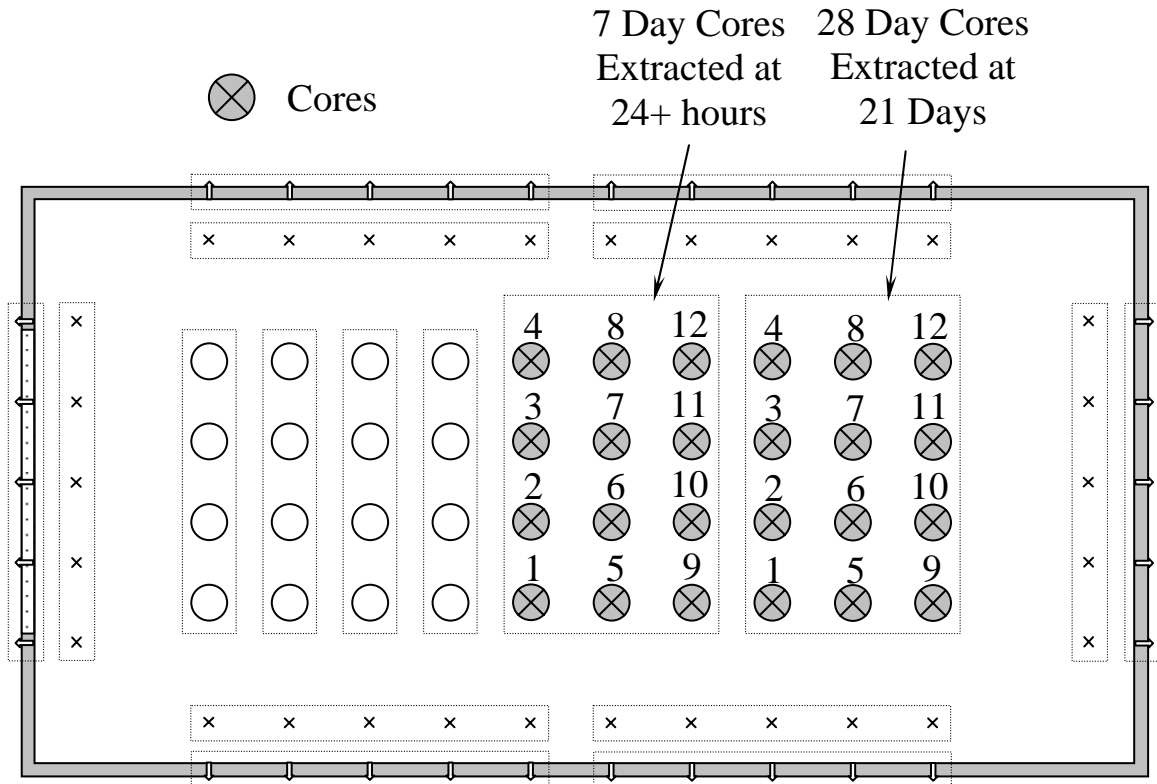

Table C-33: ASTM C 42 core strength data for warm-weather placement of mock bridge deck

Intended Age	Actual Time Tested	Concrete Age (hours)	Compressive Strength (psi)	% Range
7 Day	6/21/05 3:30 PM	170.0	3,640	21.8
			3,010	
			3,250	
			3,660	
			2,940	
28 Day	7/12/05 4:00 PM	674.5	3,860	7.5
			4,160	
			4,050	
			4,120	
			-	

* Indicates cores removed due to outliers

- Indicates no core data due to failure to remove from mock bridge deck

Table C-34: ASTM C42 core dimensions for warm-weather placement of mock bridge deck

Intended Age	Core Number	Diameter (in.)				Length (in.)		L/D
		1	2	Avg.	% Diff.	Before Capping	After Capping	
7 Day	3	3.98	3.99	3.99	0.25%	7.0	7.2	1.76
	5	3.98	3.98	3.98	0.00%	7.9	8.1	1.98
	7	3.99	3.98	3.99	0.25%	7.9	8.1	1.98
	9	4.00	4.00	4.00	0.00%	7.9	8.2	1.98
	11	3.97	3.97	3.97	0.00%	7.9	8.1	1.99
28 Day	1	3.98	3.97	3.98	0.25%	7.9	8.2	1.99
	3	3.97	3.98	3.98	0.25%	8.0	8.2	2.01
	5	3.99	3.99	3.99	0.00%	8.0	8.2	2.01
	7	3.98	3.98	3.98	0.00%	8.0	8.2	2.01
	9	-	-	-	-	-	-	-

- Indicates no core data due to failure to remove from mock bridge deck

Table C-35: AASHTO T 24 core strength data for warm-weather placement of mock bridge deck

Intended Age	Actual Time Tested	Concrete Age (hours)	Compressive Strength (psi)	% Range
7 Day	6/21/05 3:40 PM	170.2	3,220	18.2
			3,550	
			3,000	
			3,170	
			2,970	
28 Day	7/12/05 4:15 PM	674.8	4,300	10.7
			3,890	
			4,090	
			3,870	
			-	

* Indicates cores removed due to outliers

- Indicates no core data due to failure to remove from mock bridge deck

Table C-36: AASHTO T 24 core dimensions for warm-weather placement of mock bridge deck

Intended Age	Core Number	Diameter (in.)				Length (in.)		L/D
		1	2	Avg.	% Diff.	Before Capping	After Capping	
7 Day	4	3.98	3.98	3.98	0.00%	7.9	8.1	1.98
	6	3.98	3.98	3.98	0.00%	8.0	8.2	2.01
	8	3.98	3.99	3.99	0.25%	7.9	8.1	1.98
	10	3.98	3.98	3.98	0.00%	7.9	8.2	1.98
	12	3.99	3.99	3.99	0.00%	7.9	8.1	1.98
28 Day	2	3.99	3.98	3.99	0.25%	8.0	8.2	2.01
	4	3.98	3.98	3.98	0.00%	7.9	8.2	1.98
	6	3.97	3.98	3.98	0.25%	7.9	8.1	1.99
	8	3.97	3.98	3.98	0.25%	8.0	8.2	2.01
	10	-	-	-	-	-	-	-

- Indicates no core data due to failure to remove from mock bridge deck

All temperature data for the warm-weather placement of the mock bridge deck are given below. Figure C-27 shows the ambient temperatures for the entire project. The remaining temperature graphs only show the first seven days of data. The remaining temperatures were not shown because the temperatures of the specimens and mock bridge deck follow the ambient temperatures fairly closely. The first seven days were graphed to show the hydration of the concrete.

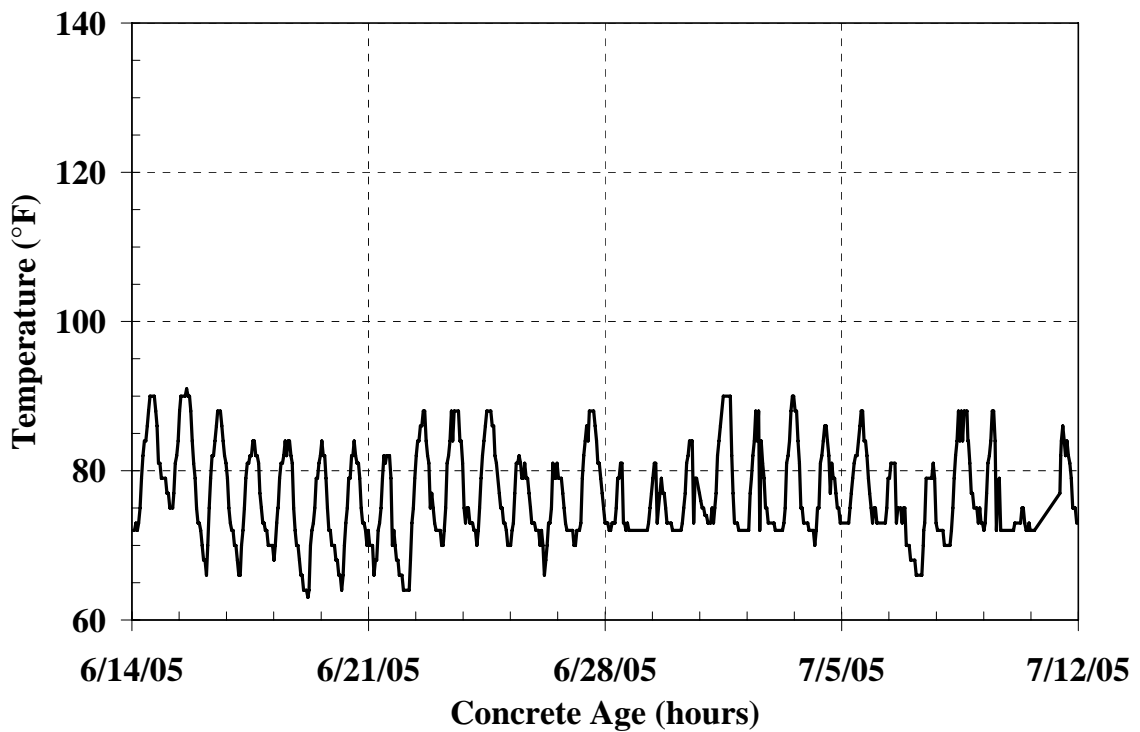

Figure C-27: Ambient air temperatures of the warm-weather placement of mock bridge deck

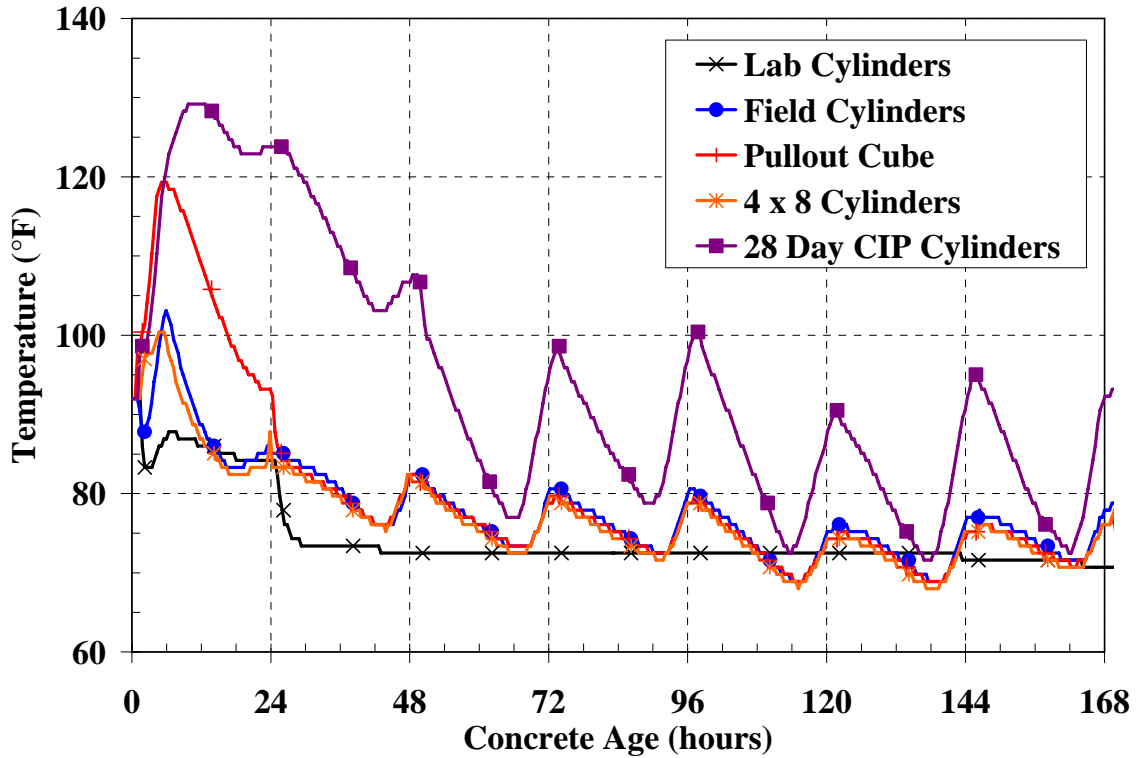

Figure C-28: Molded cylinder temperature history for warm-weather placement of mock bridge deck

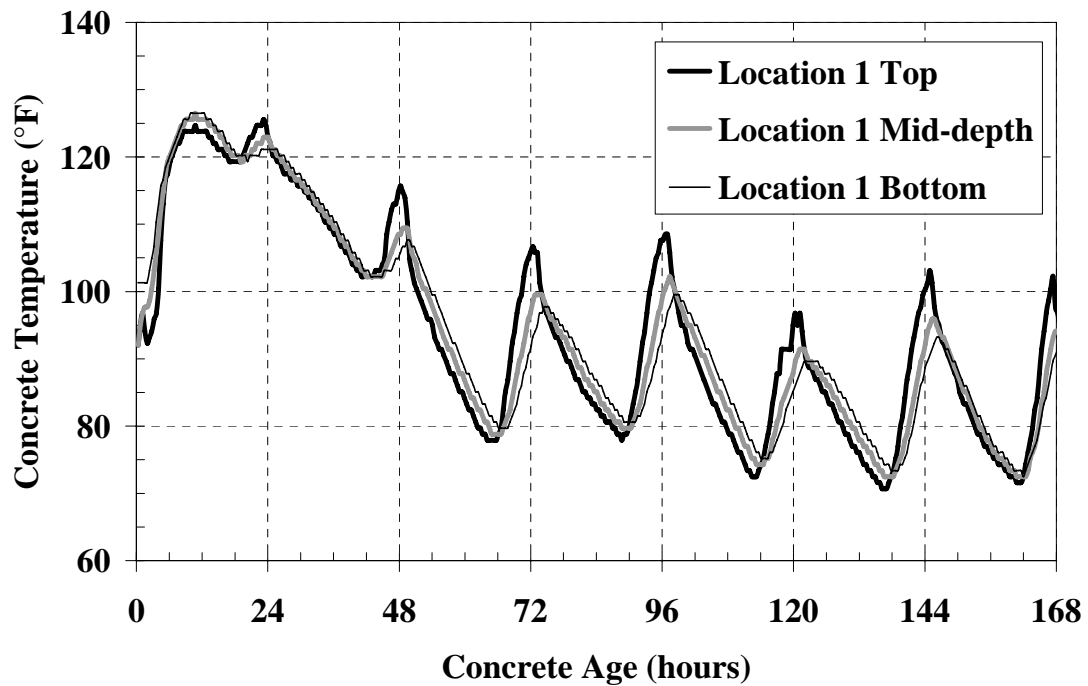

Figure C-29: Mock bridge deck temperatures Location 1 for warm-weather placement

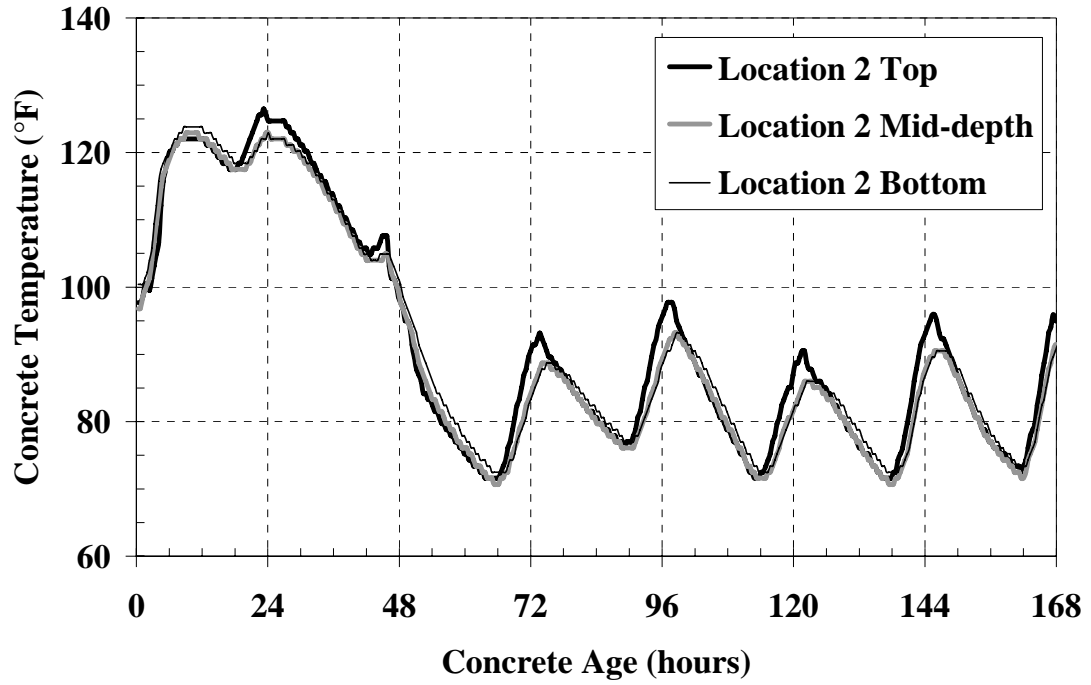

Figure C-30: Mock bridge deck temperatures Location 2 for warm-weather placement

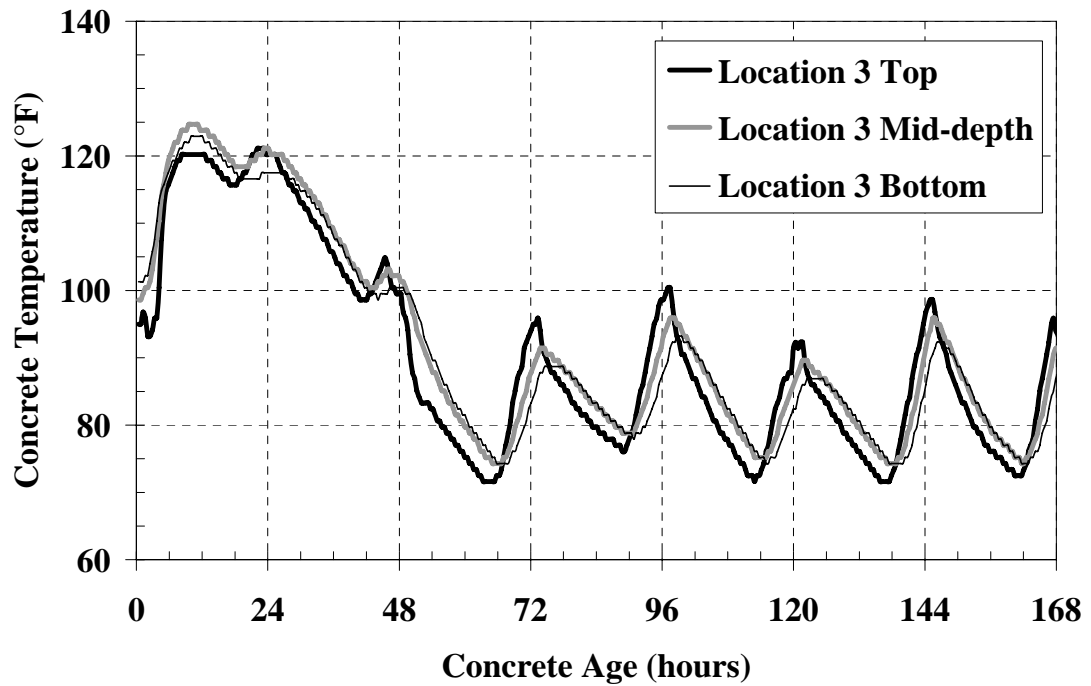

Figure C-31: Mock bridge deck temperatures Location 3 for warm-weather placement

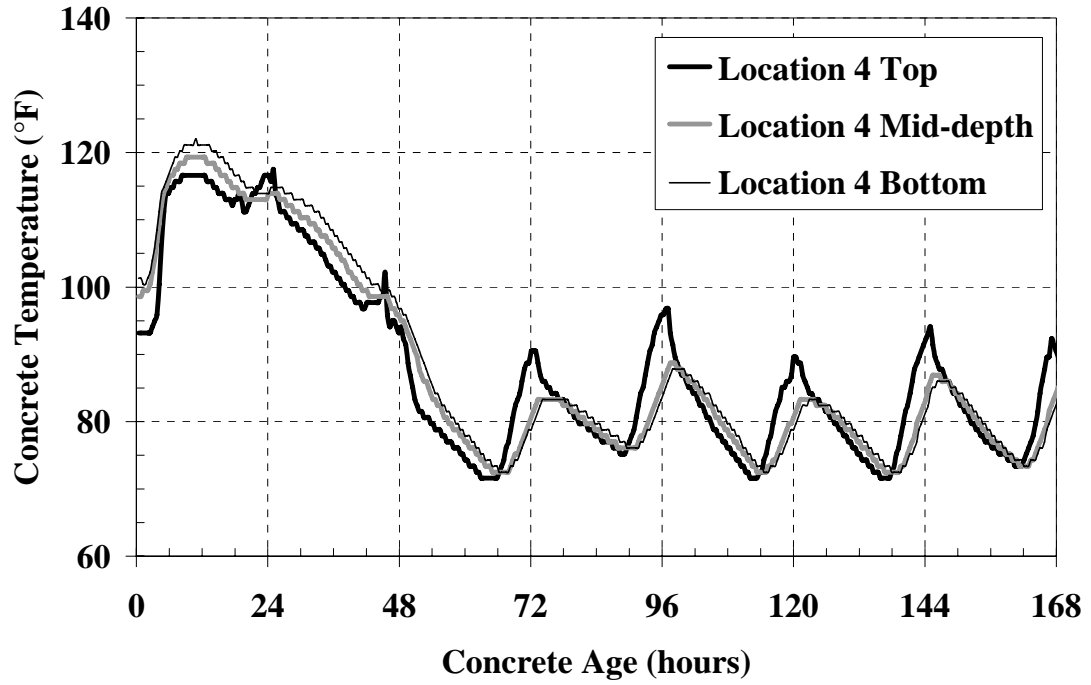

Figure C-32: Mock bridge deck temperatures Location 4 for warm-weather placement

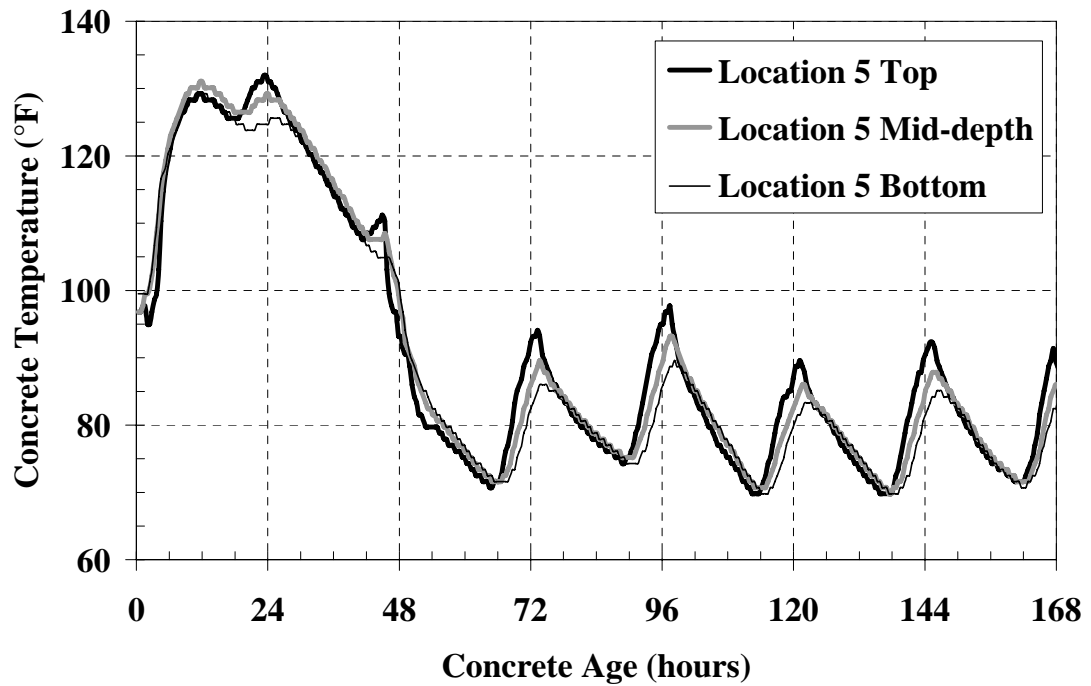

Figure C-33: Mock bridge deck temperatures Location 5 for warm-weather placement

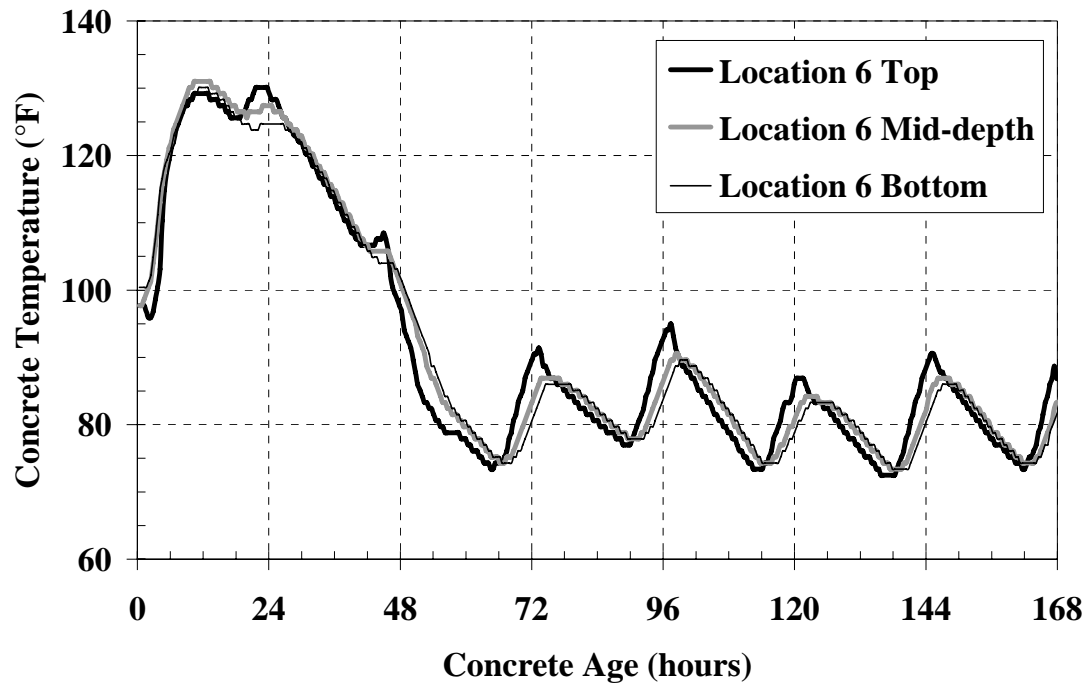

Figure C-34: Mock bridge deck temperatures Location 6 for warm-weather placement

The following tables and figures are the best-fit exponential function values for the strength-maturity relationship, the estimated cylinders and in-place strengths from the all maturity functions, and the *laboratory* and *water-tank* S-M relationships for the molded cylinders and in-place testing using the Nurse-Saul maturity function with $T_o = -10$ °C and Arrhenius maturity function with $E = 40$ kJ/mol.

Table C-37: Strength-maturity relationship exponential function values for the warm-weather placement of mock bridge deck

Curing Condition	Exponential Value	Concrete Age	Nurse-Saul Function		Arrhenius Function	
			$T_o = 0\text{ }^\circ\text{C}$	$T_o = -10\text{ }^\circ\text{C}$	$E = 33,500\text{ J/mol}$	$E = 40,000\text{ J/mol}$
<i>Lab</i>	S_u (psi)	19,950	15,457	14,335	13,616	12,892
	β	0.1821	0.2307	0.2511	0.2656	0.2845
	τ	1977.0459	18223.3828	9185.9695	331.2049	271.8200
	R^2	0.99	0.99	0.99	0.99	0.98
<i>Lime-Saturated Water Tank</i>	S_u (psi)	11,310	9,806	9,372	9,003	8,690
	β	0.2682	0.3274	0.3522	0.3776	0.4033
	τ	188.9495	4193.5450	2671.3724	108.9727	104.3841
	R^2	0.99	0.99	0.99	0.99	0.99

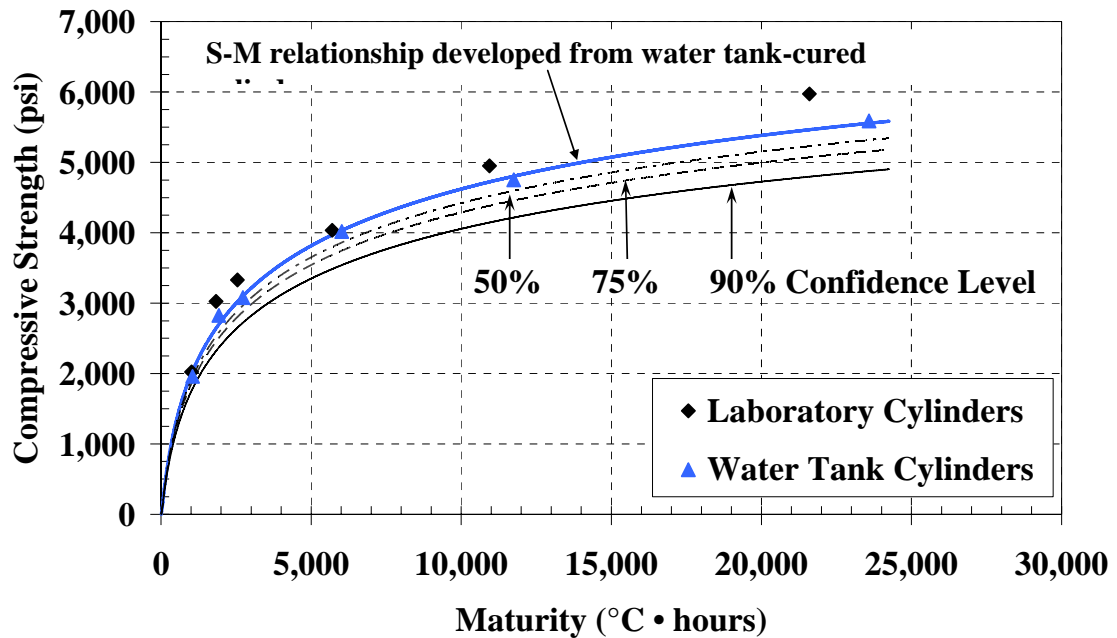

Figure C-35: Water-tank cylinders S-M relationship with confidence levels for the warm-weather placement of mock bridge deck ($T_o = -10\text{ }^\circ\text{C}$)

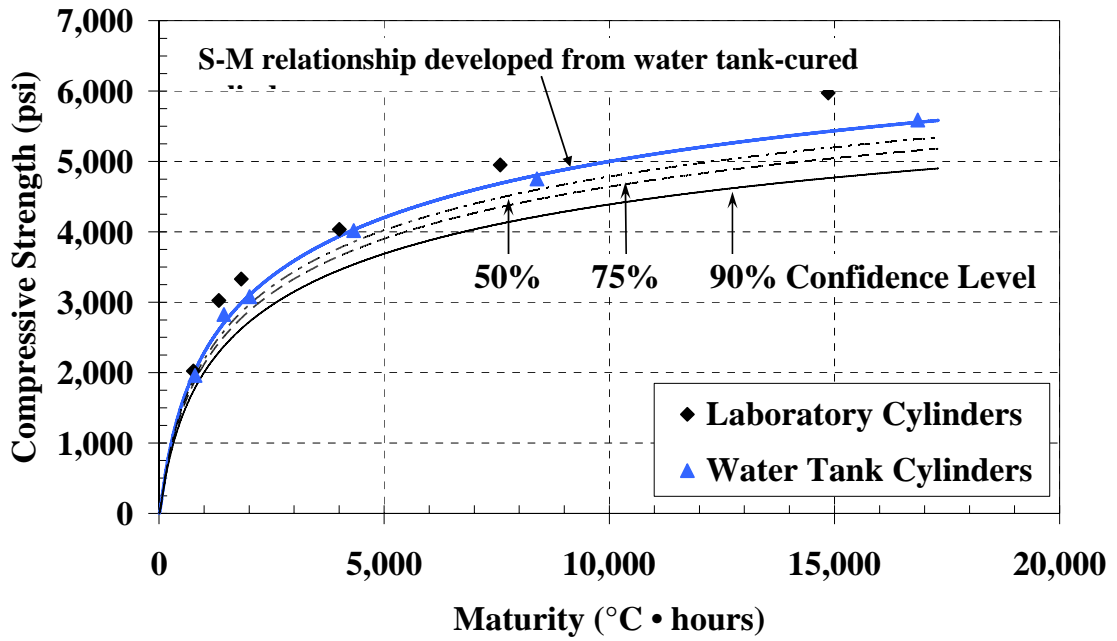

Figure C-36: Water-tank cylinders S-M relationship with confidence levels for the warm-weather placement of mock bridge deck ($T_o = 0^{\circ}\text{C}$)

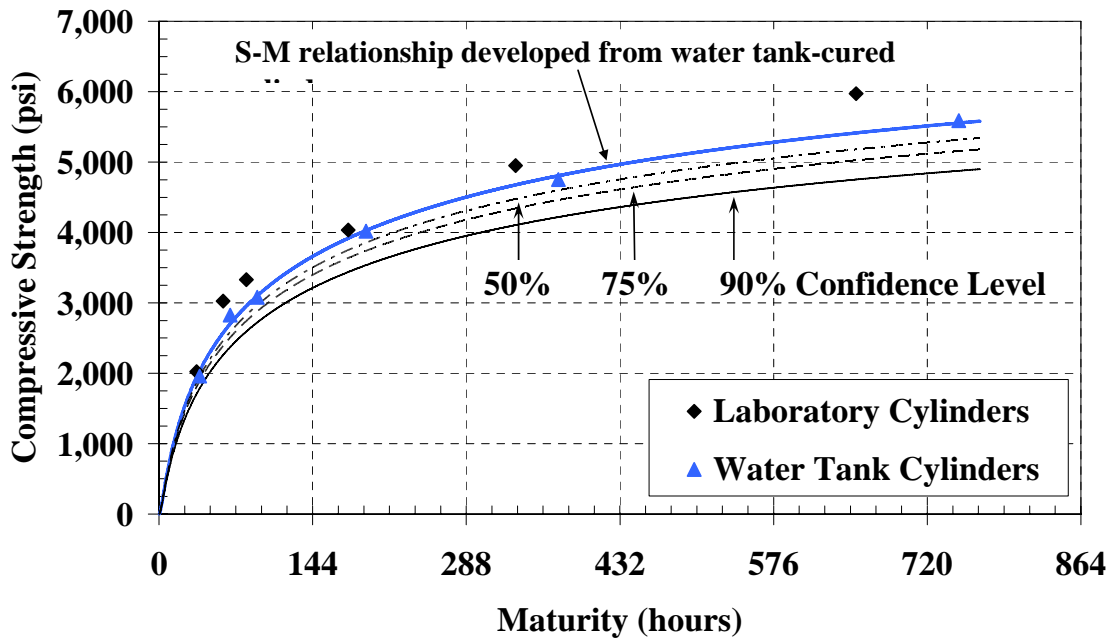

Figure C-37: Water-tank cylinders S-M relationship with confidence levels for the warm-weather placement of mock bridge deck ($E = 33.5 \text{ kJ/mol}$)

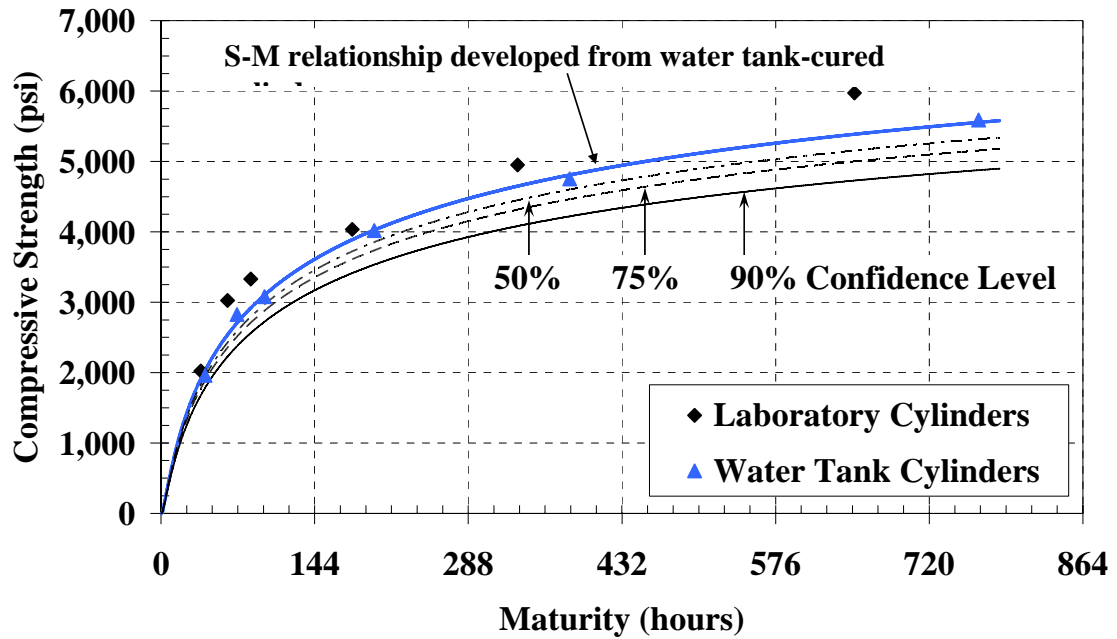

Figure C-38: Water-tank cylinders S-M relationship with confidence levels for the warm-weather placement of mock bridge deck ($E = 40 \text{ kJ/mol}$)

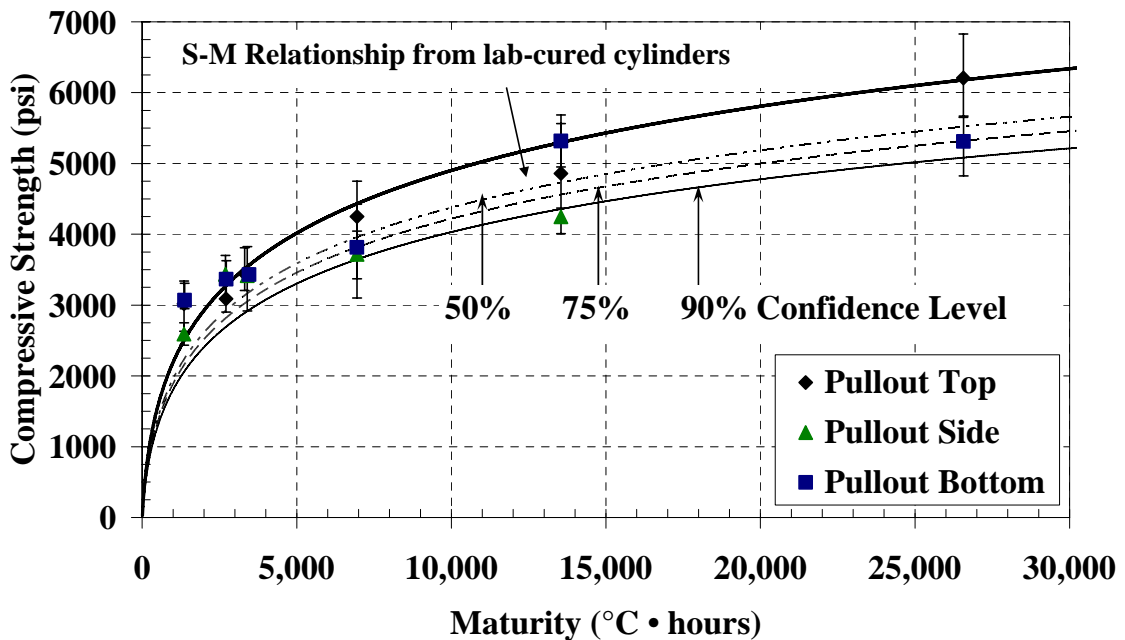

Figure C-39: Pullout test with laboratory S-M relationship and confidence levels for the warm-weather placement of the mock bridge deck ($T_o = -10 \text{ }^{\circ}\text{C}$)

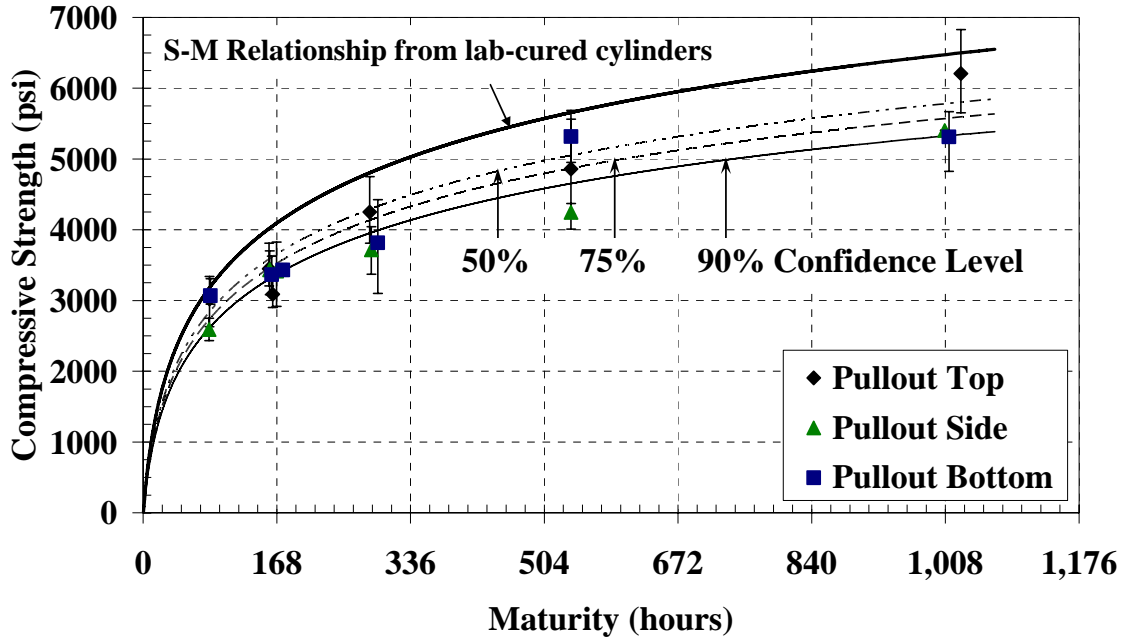

Figure C-40: Pullout test with *laboratory* S-M relationship and confidence levels for the warm-weather placement of the mock bridge deck ($E = 40 \text{ kJ/mol}$)

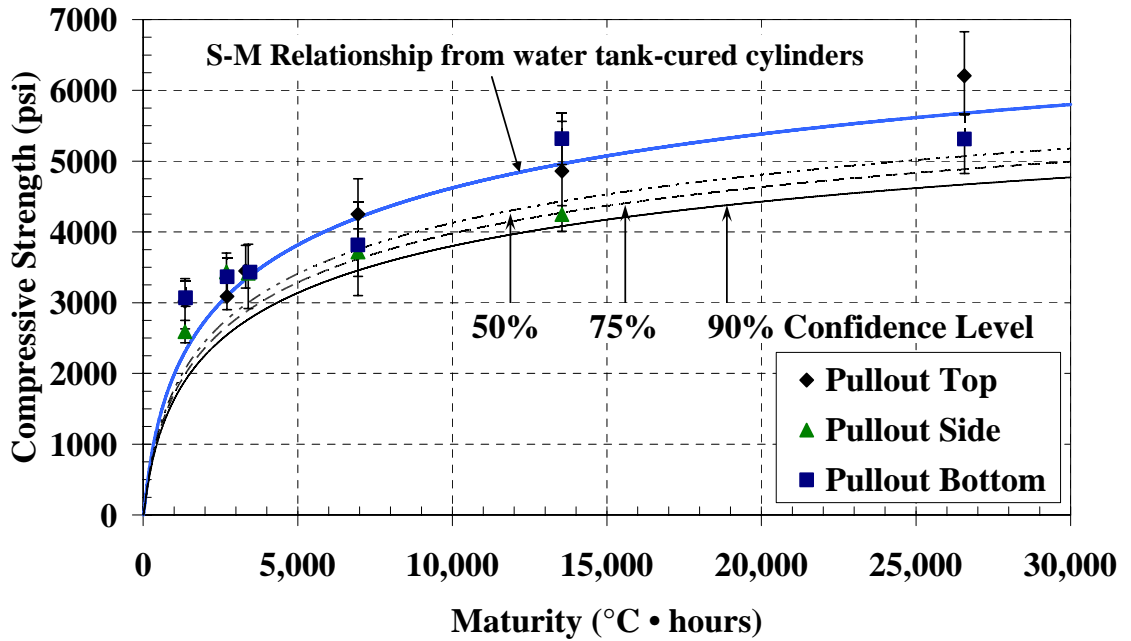

Figure C-41: Pullout test with *water-tank* S-M relationship and confidence levels for the warm-weather placement of mock bridge deck ($T_o = -10^\circ\text{C}$)

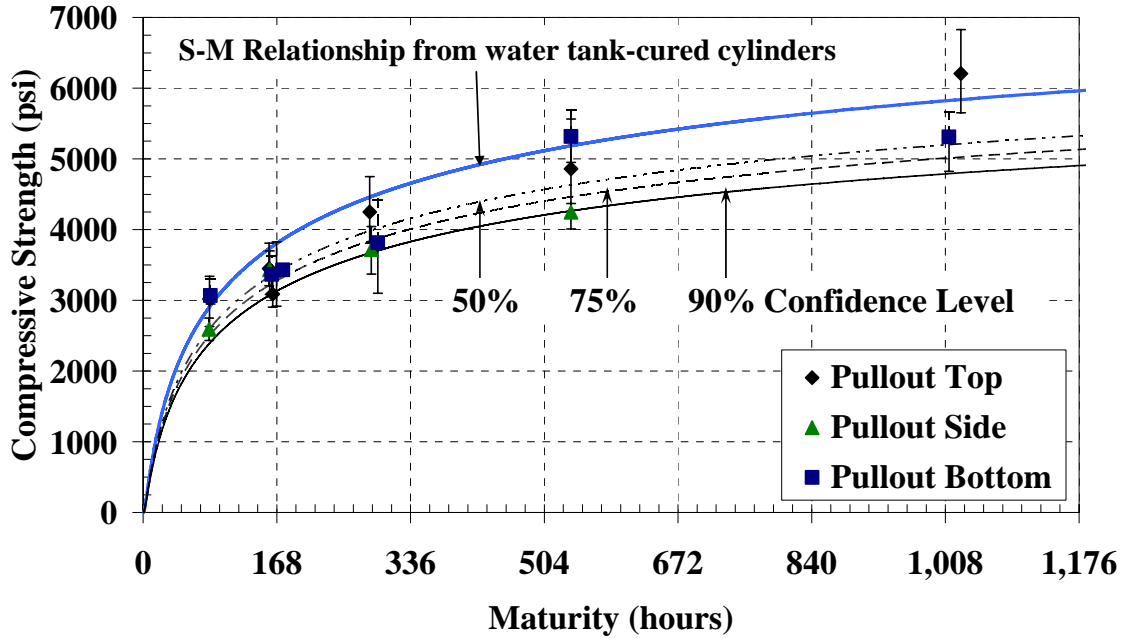

Figure C-42: Pullout test with *water-tank* S-M relationship and confidence levels for the warm-weather placement of mock bridge deck ($E = 40 \text{ kJ/mol}$)

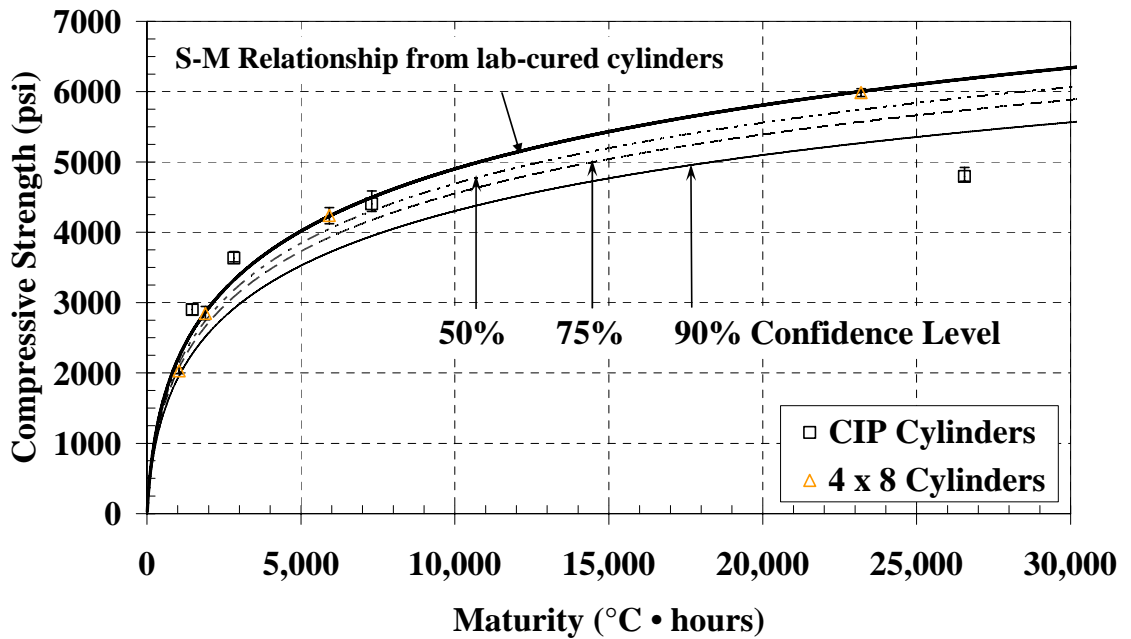

Figure C-43: Cast-in-place cylinders and 4x 8 inch cylinders with *laboratory* S-M relationship and confidence levels for the warm-weather placement of the mock bridge deck ($T_0 = -10 \text{ }^{\circ}\text{C}$)

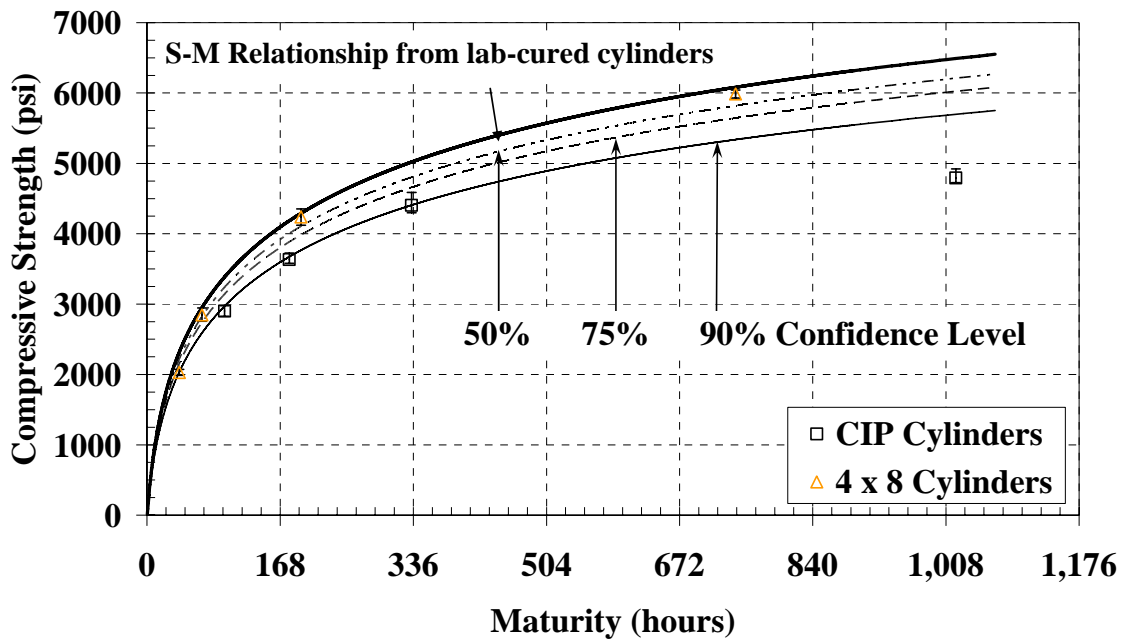

Figure C-44: Cast-in-place cylinders and 4x 8 inch cylinders with *laboratory* S-M relationship and confidence levels for the warm-weather placement of the mock bridge deck ($E = 40 \text{ kJ/mol}$)

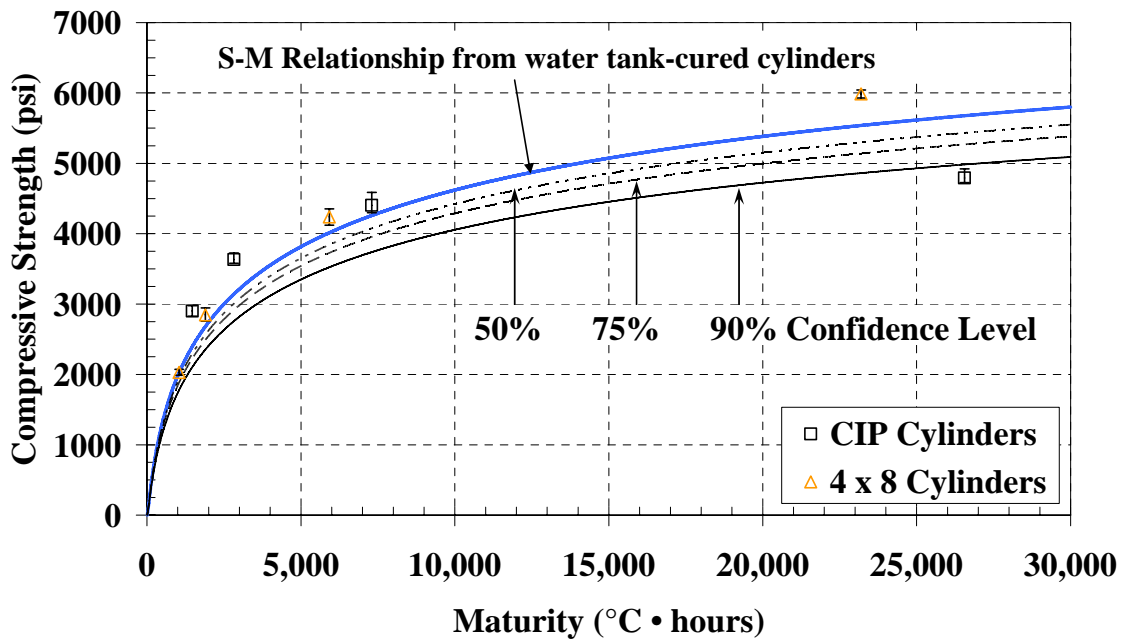

Figure C-45: Cast-in-place cylinders and 4 x 8 inch cylinders with *water-tank* S-M relationship and confidence levels for the warm-weather placement of mock bridge deck ($T_0 = -10^\circ\text{C}$)

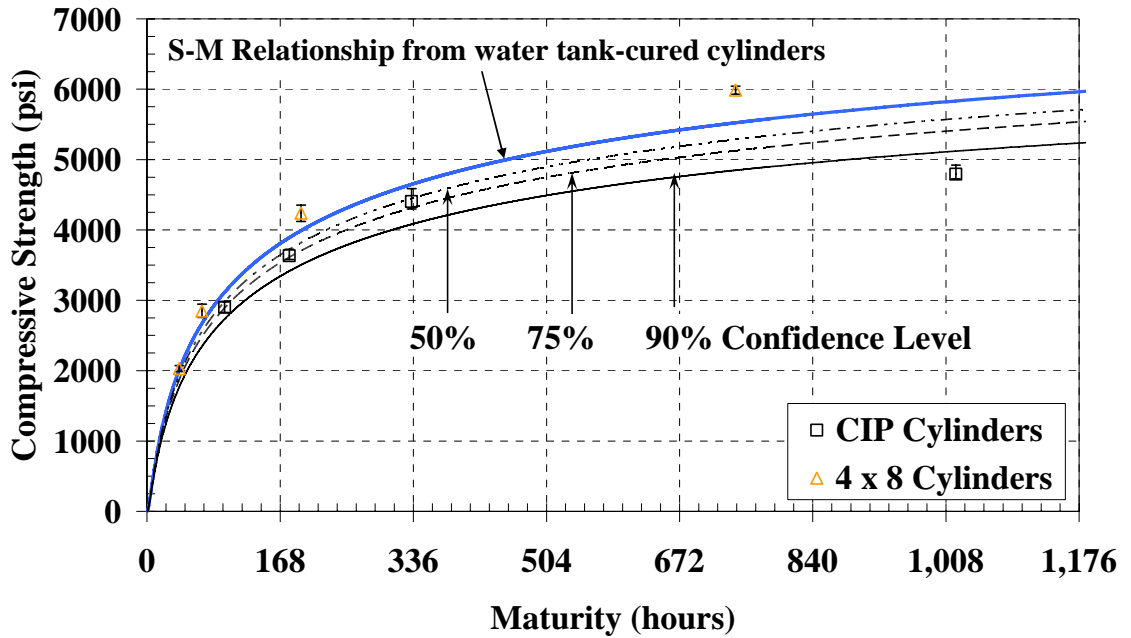

Figure C-46: Cast-in-place cylinders and 4 x 8 inch cylinders with *water-tank* S-M relationship and confidence levels for the warm-weather placement of mock bridge deck ($E = 40 \text{ kJ/mol}$)

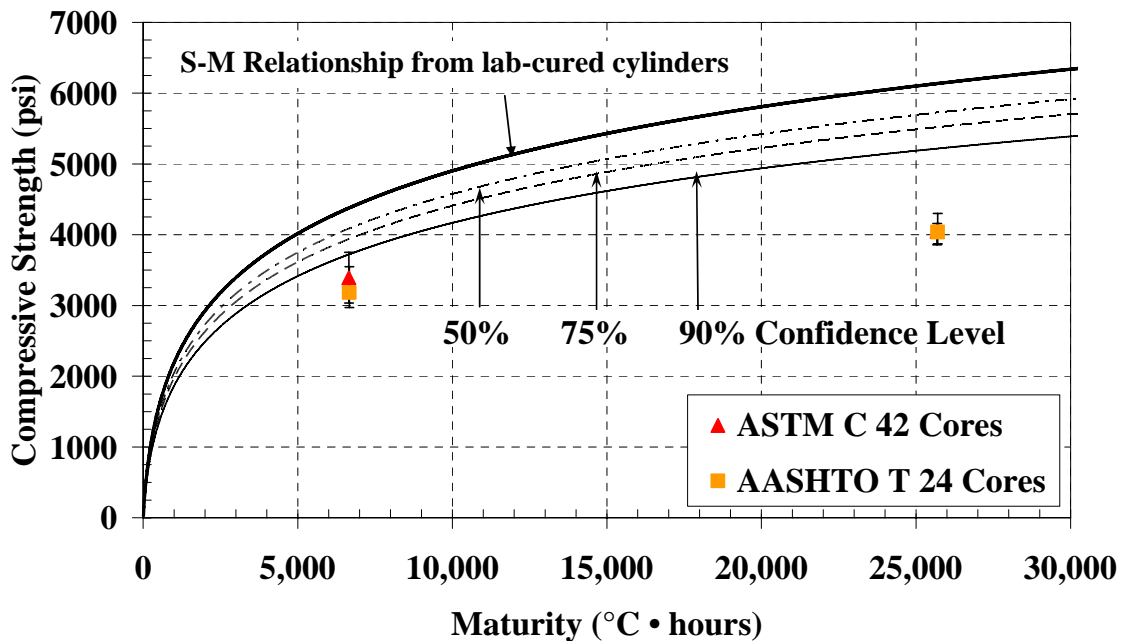

Figure C-47: Cores with *laboratory* S-M relationship and confidence levels for the warm-weather placement of the mock bridge deck ($T_o = -10 \text{ }^{\circ}\text{C}$)

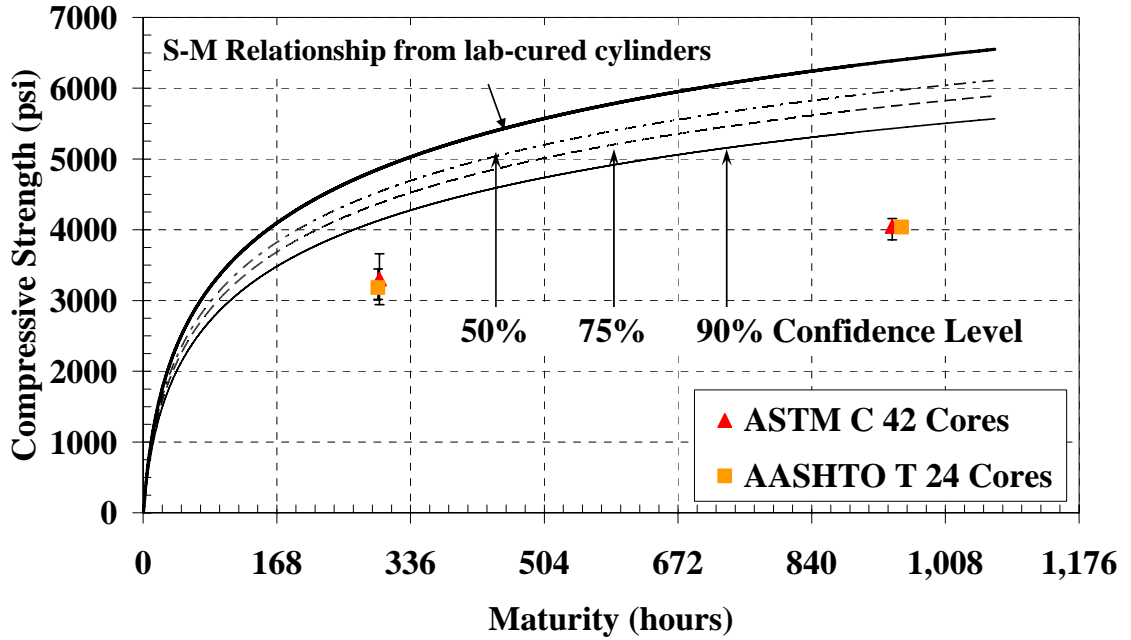

Figure C-48: Cores with *laboratory* S-M relationship and confidence levels for the warm-weather placement of the mock bridge deck ($E = 40 \text{ kJ/mol}$)

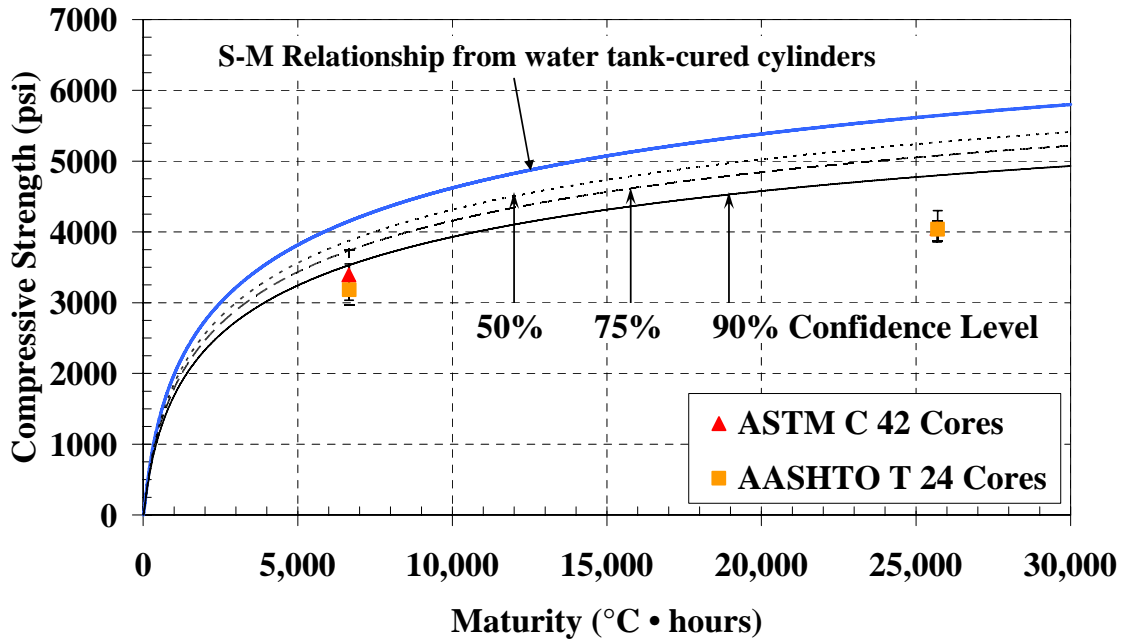

Figure C-49: Cores with *water-tank* S-M relationship and confidence levels for the warm-weather placement of mock bridge deck ($T_o = -10^{\circ}\text{C}$)

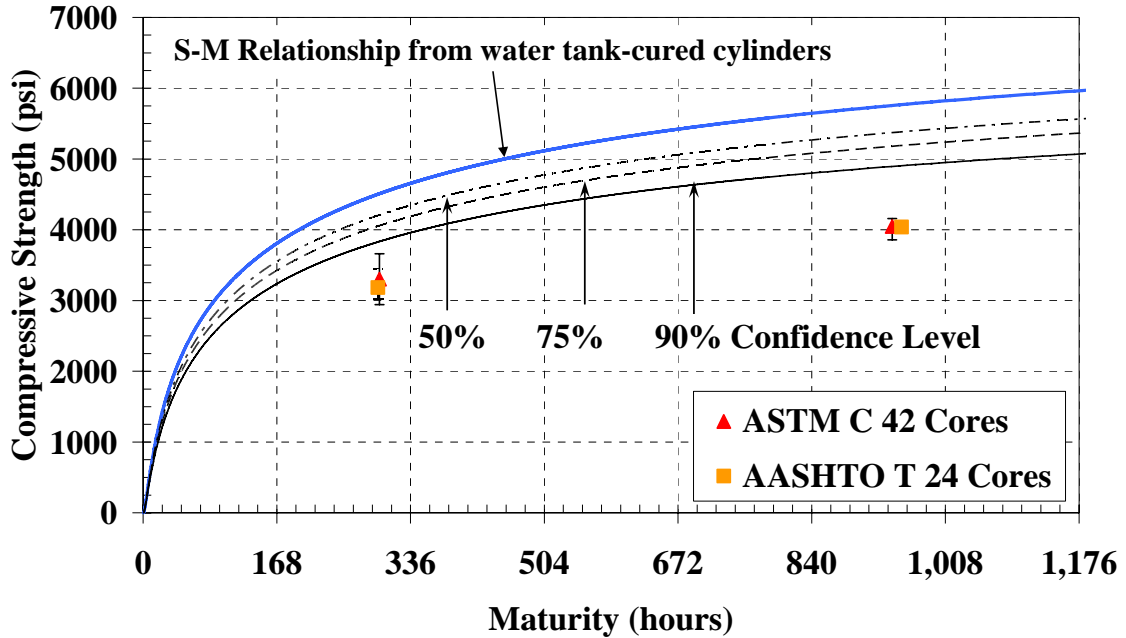

Figure C-50: Cores with *water-tank* S-M relationship and confidence levels for the warm-weather placement of mock bridge deck ($E = 40$ kJ/mol)

Table C-38: Estimated strengths using *laboratory* cylinders S-M relationship for the warm-weather placement of mock bridge deck (psi)

	Concrete Age (hours)	Measured Strength (psi)	Nurse-Saul Function (psi)		Arrhenius Function (psi)	
			$T_o = -10$ °C	$T_o = 0$ °C	$E = 40$ kJ/mol	$E = 33.5$ kJ/mol
<i>Lab Cylinders</i>	25.6	2,020	2,210	2,210	2,220	2,220
	50.3	3,020	2,830	2,820	2,820	2,820
	72.3	3,330	3,200	3,200	3,190	3,190
	170.1	4,040	4,180	4,180	4,180	4,180
	336.1	4,950	5,020	5,020	5,020	5,020
	674.2	5,970	5,910	5,910	5,910	5,910
<i>Water Tank Cylinder</i>	25.4	1,960	2,000	1,980	1,910	1,940
	49.0	2,830	2,640	2,610	2,540	2,570
	72.2	3,080	3,020	2,990	2,920	2,950
	169.8	4,020	3,970	3,940	3,890	3,920
	335.9	4,750	4,720	4,690	4,650	4,680
	673.8	5,590	5,460	5,430	5,390	5,410

Table C-39: Estimated strengths using *water-tank* cylinders S-M relationship for the warm-weather placement of mock bridge deck (psi)

	Concrete Age (hours)	Measured Strength (psi)	Nurse-Saul Function (psi)		Arrhenius Function (psi)	
			T _o = -10 °C	T _o = 0 °C	E = 40 kJ/mol	E = 33.5 kJ/mol
<i>Lab Cylinders</i>	25.6	2,020	2,240	2,260	2,330	2,300
	50.3	3,020	2,880	2,920	2,980	2,950
	72.3	3,330	3,280	3,310	3,370	3,340
	170.1	4,040	4,250	4,280	4,330	4,300
	336.1	4,950	5,110	5,150	5,200	5,170
	674.2	5,970	6,020	6,070	6,120	6,090
<i>Water Tank Cylinder</i>	25.4	1,960	2,030	2,030	2,030	2,030
	49.0	2,830	2,700	2,700	2,700	2,700
	72.2	3,080	3,100	3,100	3,100	3,100
	169.8	4,020	4,030	4,030	4,030	4,030
	335.9	4,750	4,800	4,800	4,810	4,810
	673.8	5,590	5,560	5,560	5,560	5,560

Table C-40: 4 x 8 inch cylinder test estimated strength using *laboratory* S-M relationship for the warm-weather placement of mock bridge deck (psi)

Concrete Age (Days)	Measured Strength (psi)	Nurse-Saul Function		Arrhenius Function	
		T _o = -10 °C	T _o = 0 °C	E = 40 kJ/mol	E = 33.5 kJ/mol
1.0	2,030	2,230	2,250	2,320	2,290
2.0	2,850	2,860	2,890	2,950	2,920
7.1	4,240	4,230	4,250	4,290	4,270
28.1	5,990	6,000	6,040	6,080	6,050

Table C-41: 4 x 8 inch cylinder test estimated strength using *water-tank* S-M relationship for the warm-weather placement of mock bridge deck (psi)

Concrete Age (Days)	Measured Strength (psi)	Nurse-Saul Function		Arrhenius Function	
		T _o = -10 °C	T _o = 0 °C	E = 40 kJ/mol	E = 33.5 kJ/mol
1.0	2,030	2,030	2,020	2,010	2,020
2.0	2,850	2,680	2,680	2,670	2,670
7.1	4,240	4,010	4,000	3,990	4,000
28.1	5,990	5,540	5,530	5,520	5,530

Table C-42: Cast-in-place cylinder test estimated strength using *laboratory* S-M relationship for the warm-weather placement of mock bridge deck (psi)

Concrete Age (Days)	Measured Strength (psi)	Nurse-Saul Function		Arrhenius Function	
		T _o = -10 °C	T _o = 0 °C	E = 40 kJ/mol	E = 33.5 kJ/mol
1.0	2,900	2,590	2,730	3,390	3,140
2.0	3,630	3,320	3,500	4,180	3,910
7.1	4,400	4,500	4,620	5,020	4,840
28.1	4,790	6,180	6,290	6,490	6,390

Table C-43: Cast-in-place cylinder test estimated strength using *water-tank* S-M relationship for the warm-weather placement of mock bridge deck (psi)

Concrete Age (Days)	Measured Strength (psi)	Nurse-Saul Function		Arrhenius Function	
		T _o = -10 °C	T _o = 0 °C	E = 40 kJ/mol	E = 33.5 kJ/mol
1.0	2,900	2,400	2,510	3,120	2,900
2.0	3,630	3,140	3,280	3,890	3,660
7.1	4,400	4,260	4,340	4,650	4,520
28.1	4,790	5,680	5,720	5,830	5,780

Table C-44: Core test estimated strength using *laboratory* S-M relationship for the warm-weather placement of mock bridge deck (psi)

Concrete Age (Days)	Curing Method	Measured Strength (psi)	Nurse-Saul Function		Arrhenius Function	
			T _o = -10 °C	T _o = 0 °C	E = 40 kJ/mol	E = 33.5 kJ/mol
7.1	ASTM C 42	3,300	4,380	4,460	4,860	4,700
	AASHTO T 24	3,180	4,380	4,460	4,850	4,690
28.1	ASTM C 42	4,050	6,140	6,210	6,390	6,300
	AASHTO T 24	4,040	6,140	6,220	6,400	6,310

Table C-45: Core test estimated strength using *water-tank* S-M relationship for the warm-weather placement of mock bridge deck (psi)

Concrete Age (Days)	Test Area	Measured Strength (psi)	Nurse-Saul Function		Arrhenius Function	
			T _o = -10 °C	T _o = 0 °C	E = 40 kJ/mol	E = 33.5 kJ/mol
7.1	ASTM C 42	3,300	4,150	4,190	4,510	4,390
	AASHTO T 24	3,180	4,150	4,190	4,500	4,390
28.1	ASTM C 42	4,050	5,640	5,660	5,760	5,720
	AASHTO T 24	4,040	5,640	5,670	5,770	5,730

Table C-46: Pullout cube estimated strength from *water-tank* S-M relationship for the warm-weather placement of mock bridge deck (psi)

Concrete Age (hours)	Nurse-Saul Function		Arrhenius Function		Measured Strength (psi)
	T _o = -10 °C	T _o = 0 °C	E = 33.5 kJ/mol	E = 40 kJ/mol	
24.3	2,200	2,260	2,430	2,540	2,170
48.5	2,810	2,850	2,960	3,040	2,640
168.8	4,060	4,070	4,110	4,140	3,630

Table C-47: Mock bridge deck estimated pullout strength using *laboratory* S-M relationship for the warm-weather placement (psi)

Concrete Age (hours)	Insert Location	Measured Strength (psi)	Nurse-Saul Function		Arrhenius Function	
			T _o = -10 °C	T _o = 0 °C	E = 40 kJ/mol	E = 33.5 kJ/mol
24.0	Top	3,020	2,500	2,630	3,180	2,970
	Side	2,590	2,500	2,620	3,170	2,960
	Bottom	3,070	2,510	2,640	3,200	2,980
48.4	Top	3,090	3,280	3,440	4,050	3,810
	Side	3,430	3,270	3,430	4,020	3,780
	Bottom	3,370	3,280	3,440	4,040	3,800
71.5	Top	3,450	3,510	3,630	4,020	3,850
	Side	3,420	3,540	3,670	4,090	3,910
	Bottom	3,430	3,560	3,700	4,150	3,960
168.5	Top	4,250	4,430	4,540	4,810	4,680
	Side	3,720	4,430	4,540	4,810	4,680
	Bottom	3,820	4,430	4,540	4,850	4,710
335.5	Top	4,860	5,300	5,410	5,660	5,540
	Side	4,250	5,300	5,410	5,660	5,540
	Bottom	5,320	5,300	5,410	5,660	5,540
672.3	Top	6,210	6,180	6,290	6,500	6,390
	Side	-	6,180	6,290	6,470	6,370
	Bottom	5,310	6,180	6,290	6,480	6,380

Table C-48: Mock bridge deck estimated pullout strength using *water-tank* S-M relationship for the warm-weather placement (psi)

Concrete Age (hours)	Insert Location	Measured Strength (psi)	Nurse-Saul Function		Arrhenius Function	
			T _o = -10 °C	T _o = 0 °C	E = 40 kJ/mol	E = 33.5 kJ/mol
24.0	Top	3,020	2,300	2,410	2,910	2,720
	Side	2,590	2,300	2,400	2,900	2,710
	Bottom	3,070	2,320	2,420	2,920	2,730
48.4	Top	3,090	3,100	3,230	3,770	3,560
	Side	3,430	3,090	3,220	3,740	3,540
	Bottom	3,370	3,100	3,230	3,760	3,550
71.5	Top	3,450	3,330	3,420	3,730	3,600
	Side	3,420	3,360	3,450	3,800	3,660
	Bottom	3,430	3,380	3,480	3,860	3,710
168.5	Top	4,250	4,200	4,260	4,460	4,370
	Side	3,720	4,200	4,260	4,470	4,380
	Bottom	3,820	4,200	4,260	4,500	4,410
335.5	Top	4,860	4,960	5,020	5,190	5,110
	Side	4,250	4,960	5,020	5,190	5,110
	Bottom	5,320	4,960	5,020	5,190	5,110
672.3	Top	6,210	5,680	5,720	5,840	5,790
	Side	-	5,680	5,720	5,820	5,770
	Bottom	5,310	5,680	5,720	5,830	5,780

C.3 EVALUATION OF THE USE OF MOLDED CYLINDERS FOR VERIFICATION TESTING

All temperature data for the actual bridge decks are given below. Figure C-51 shows the ambient temperatures for the I-85 Bridge deck and Figure C-52 shows the ambient temperatures for the Creek Bridge deck. The remaining temperature graphs only show the first eight days of data. The remaining temperatures were not shown because the temperatures of the bridge decks follow the ambient temperature pattern closely. The first eight days were graphed to show the hydration of the concrete. The temperature sensors at Creek Bridge deck Location 4 and 6 top were lost during construction.

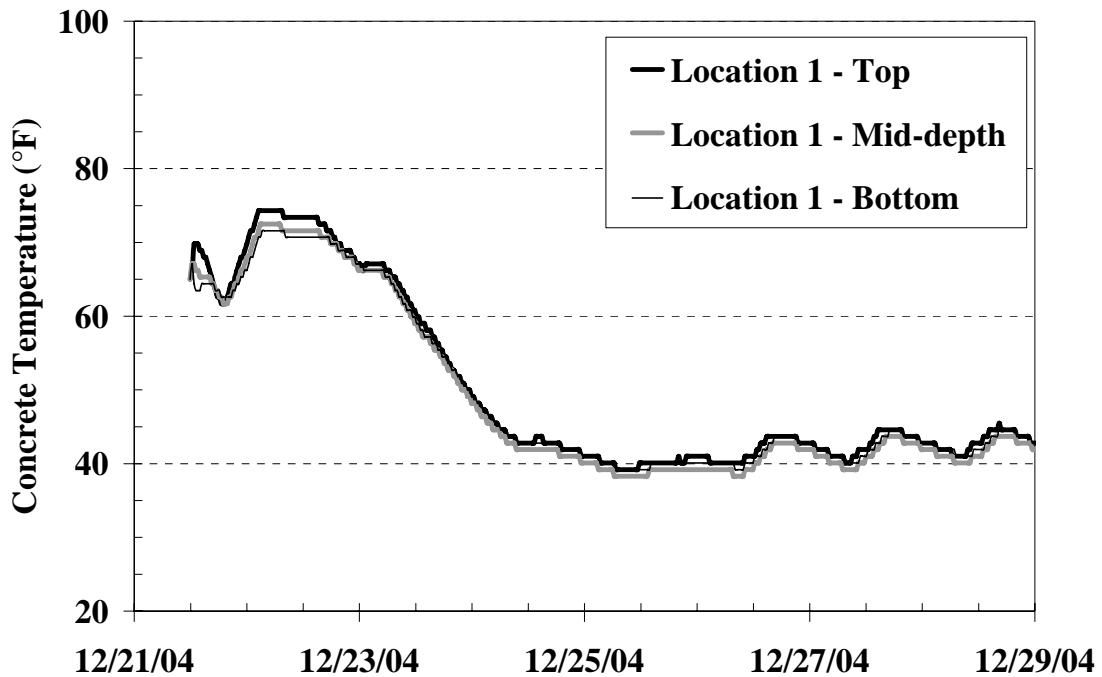

Figure C-51: Temperature history of Location 1 from the I-85 Bridge

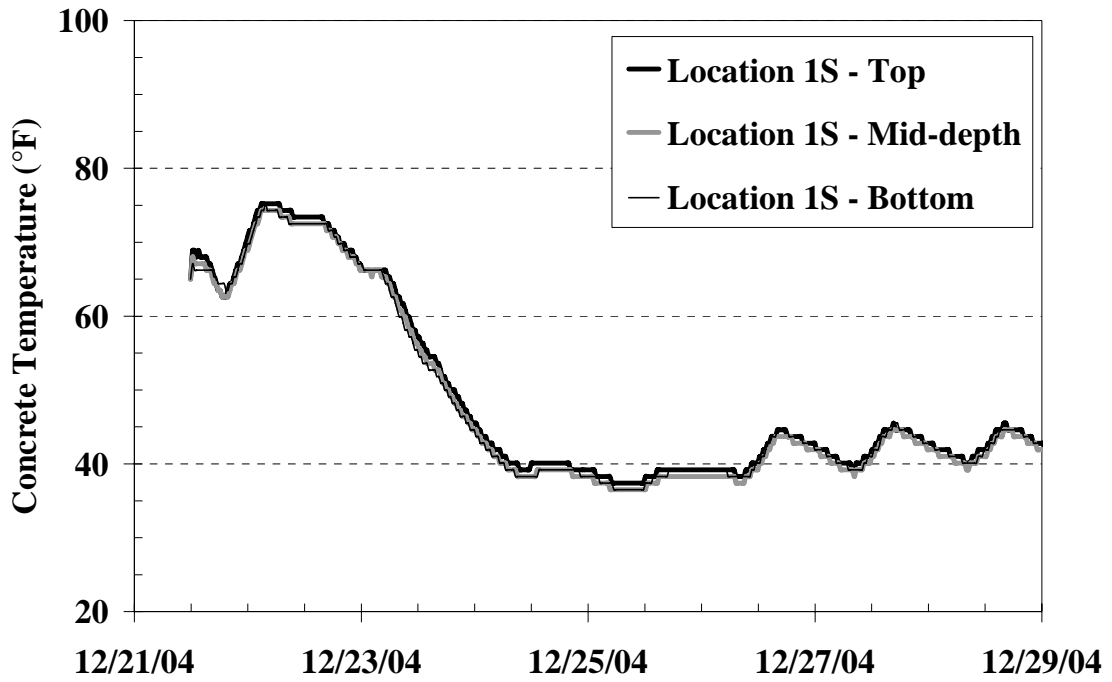

Figure C-52: Temperature history of Location 1S from the I-85 Bridge

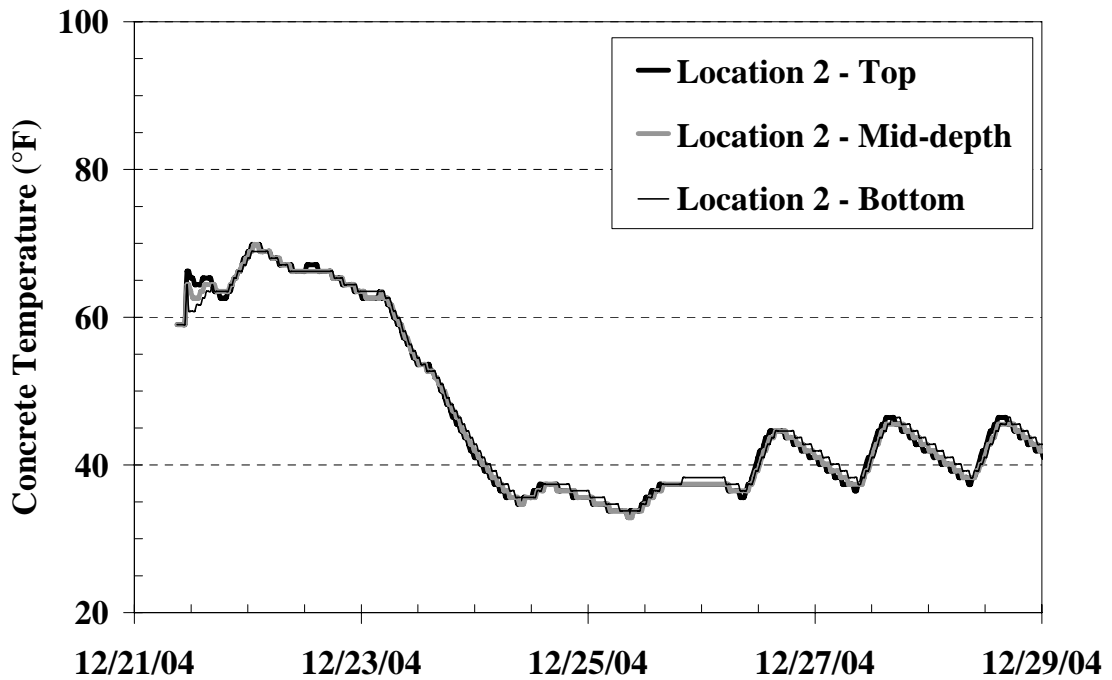

Figure C-53: Temperature history of Location 2 from the I-85 Bridge

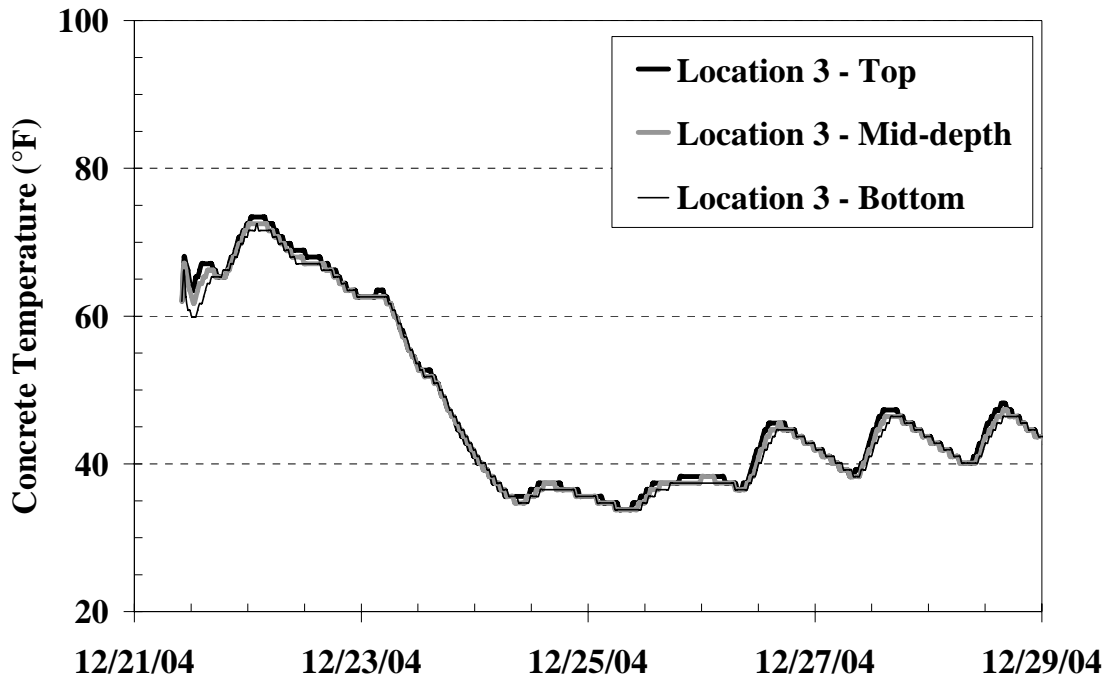

Figure C-54: Temperature history of Location 3 from the I-85 Bridge

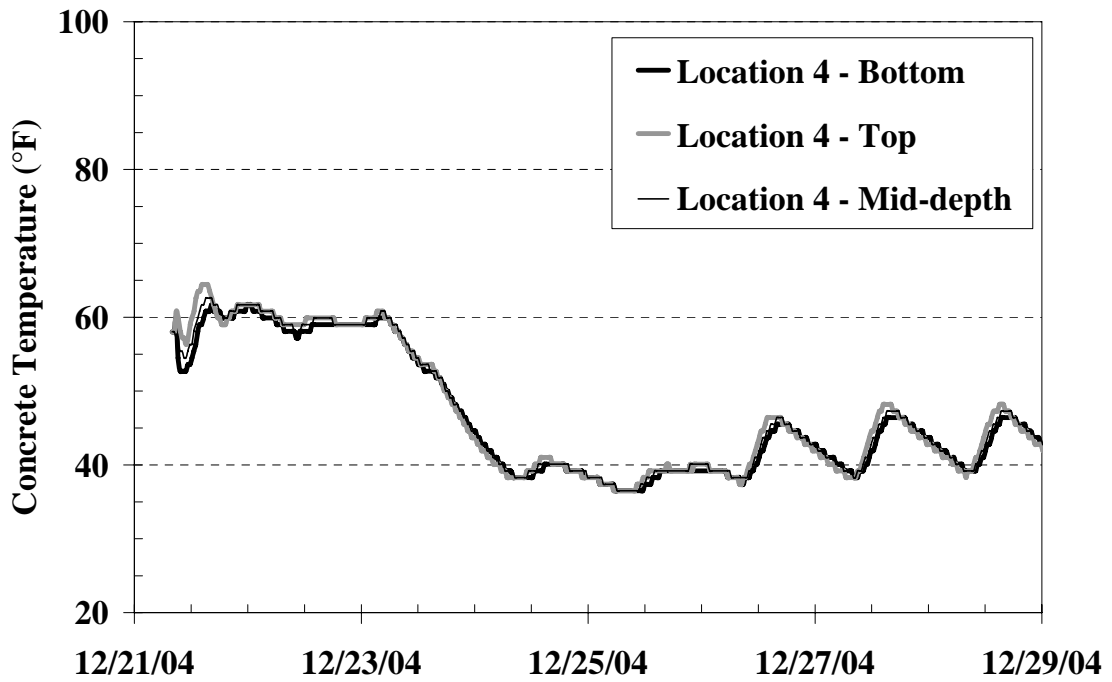

Figure C-55: Temperature history of Location 4 from the I-85 Bridge

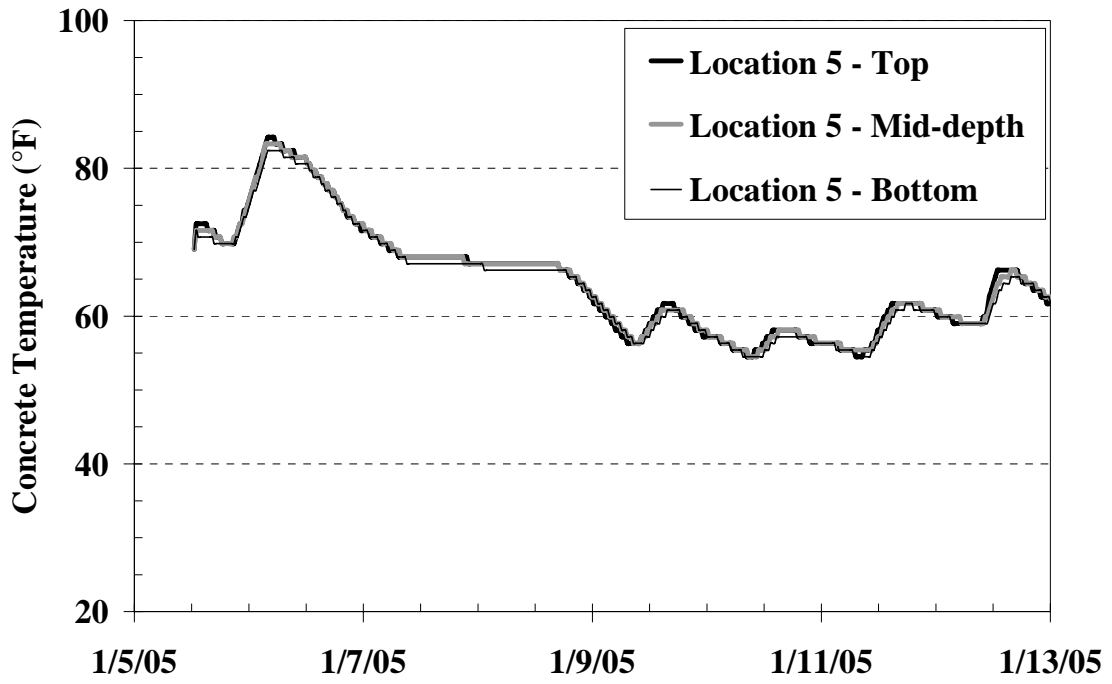

Figure C-56: Temperature history of Location 5 from the I-85 Bridge

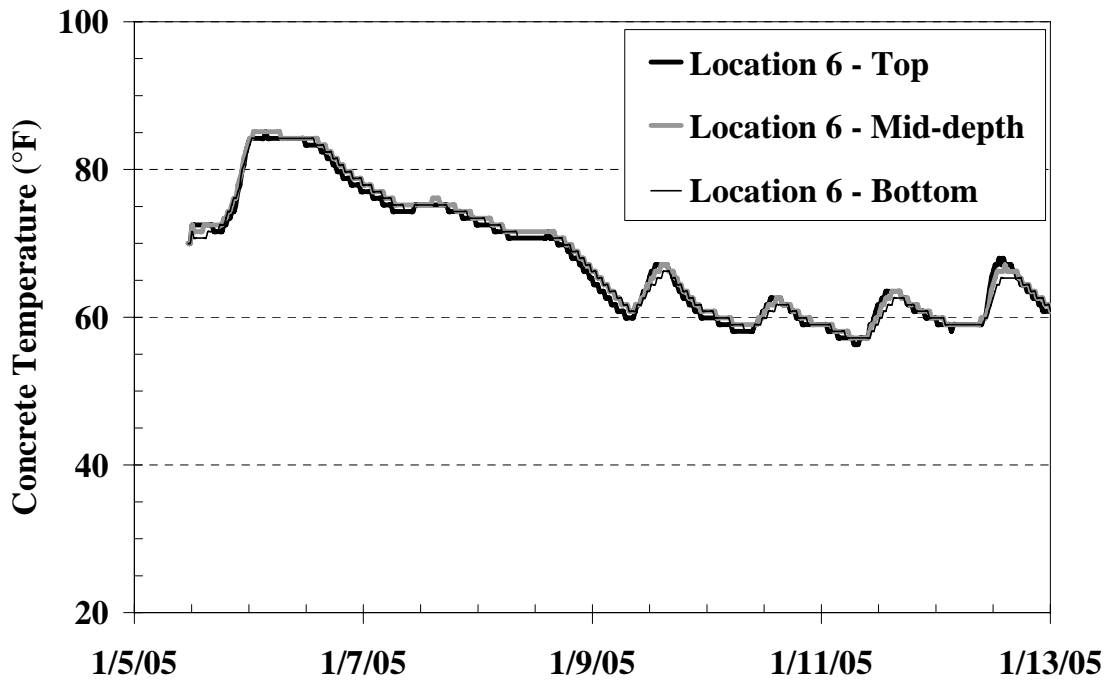

Figure C-57: Temperature history of Location 6 from the I-85 Bridge

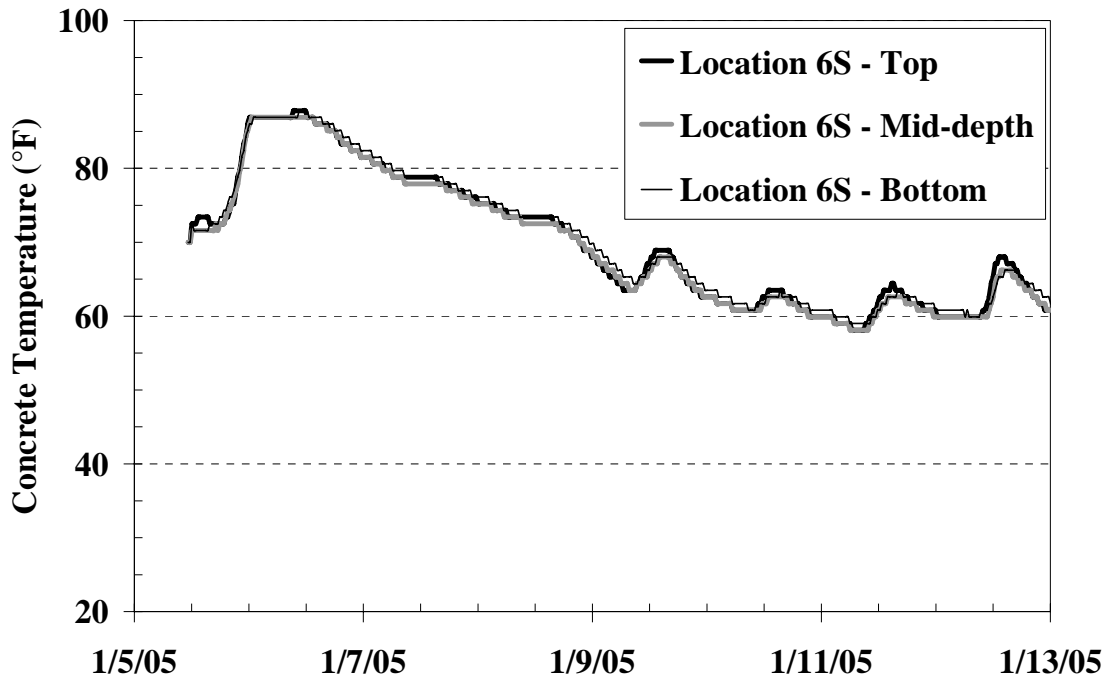

Figure C-58: Temperature history of Location 6S from the I-85 Bridge

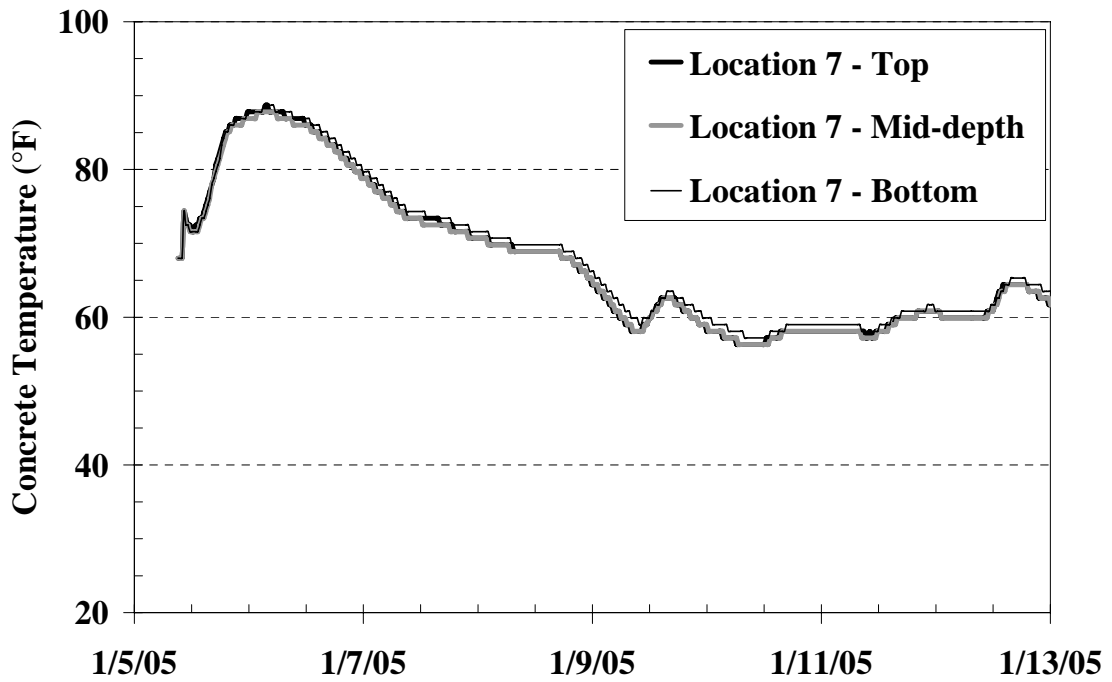

Figure C-59: Temperature history of Location 7 from the I-85 Bridge

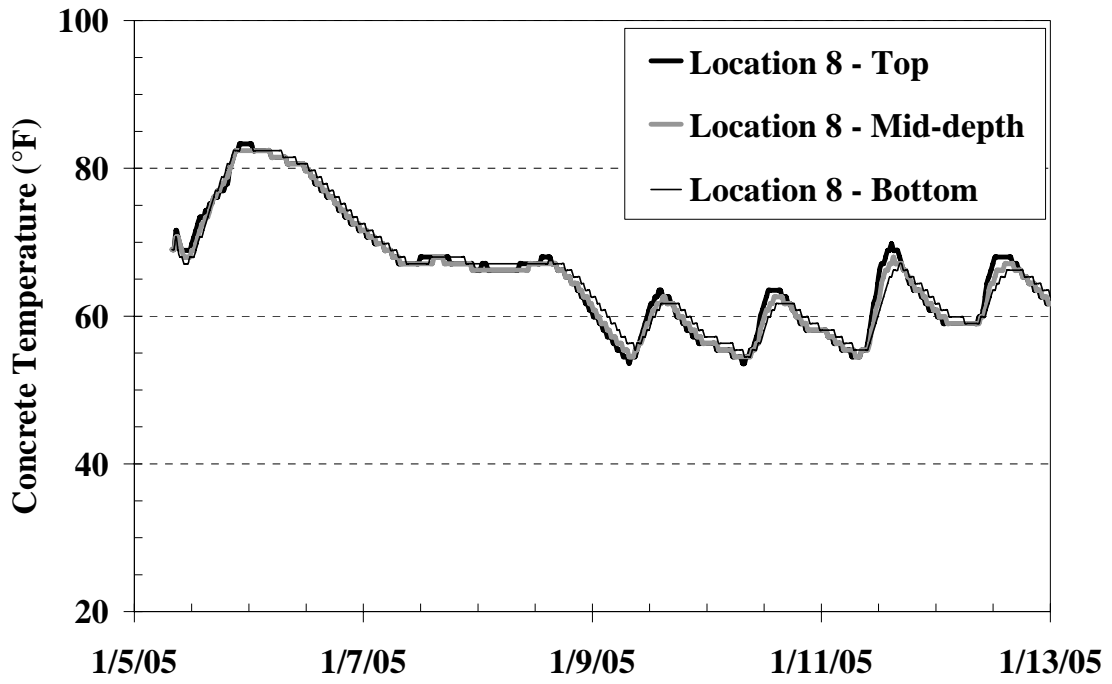

Figure C-60: Temperature history of Location 8 from the I-85 Bridge

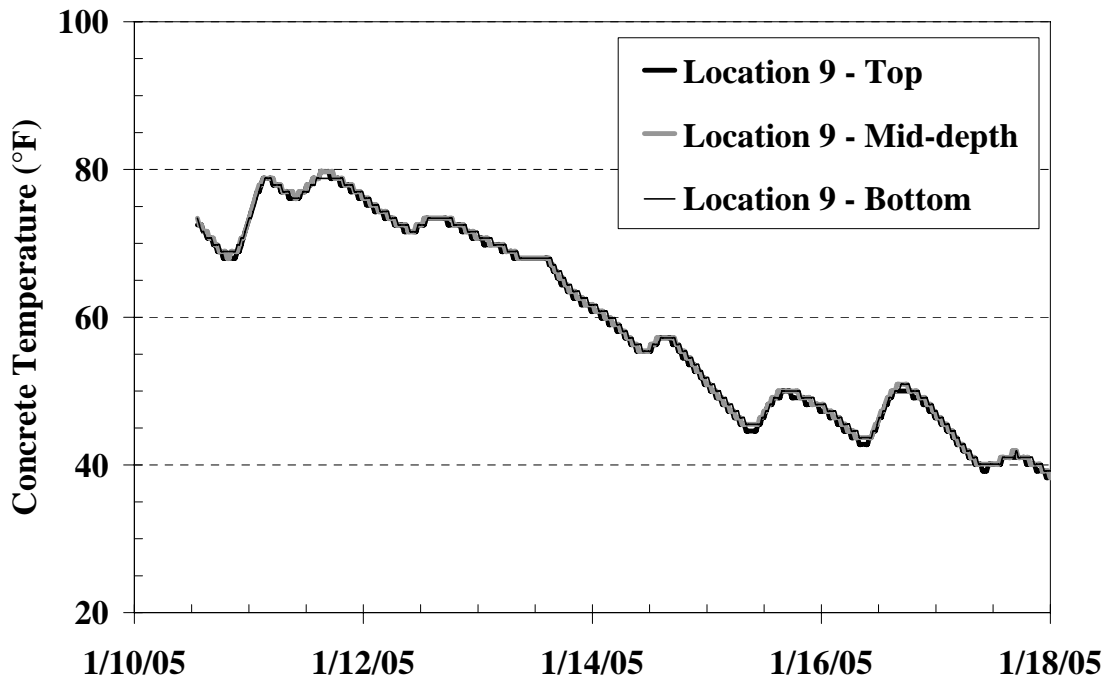

Figure C-61: Temperature history of Location 9 from the I-85 Bridge

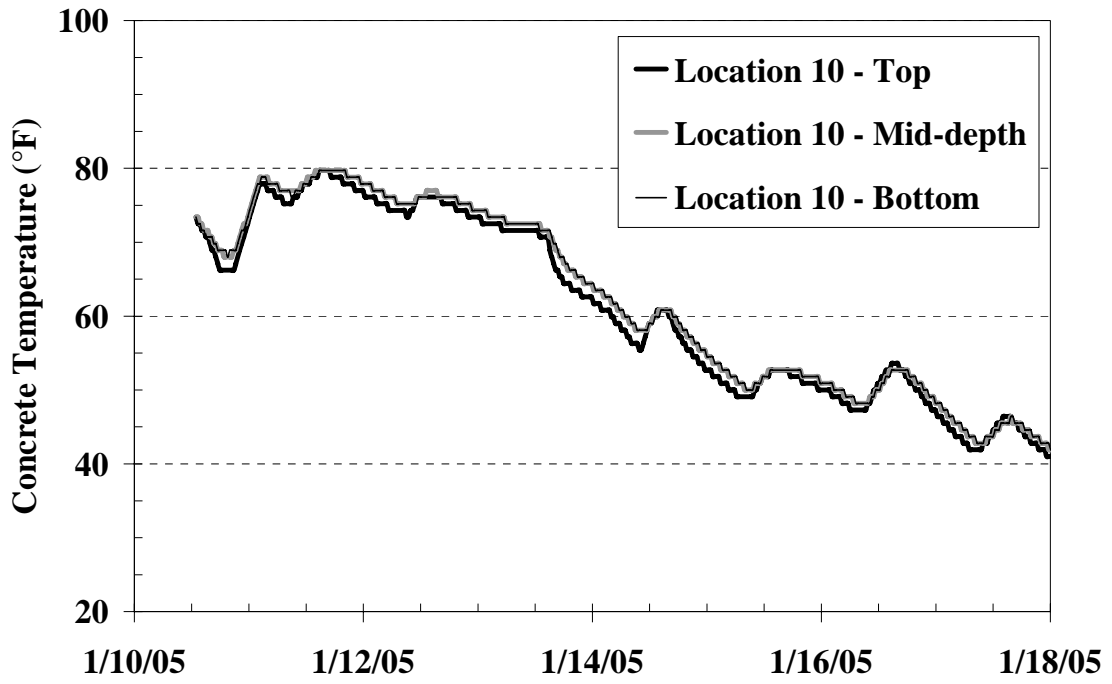

Figure C-62: Temperature history of Location 10 from the I-85 Bridge

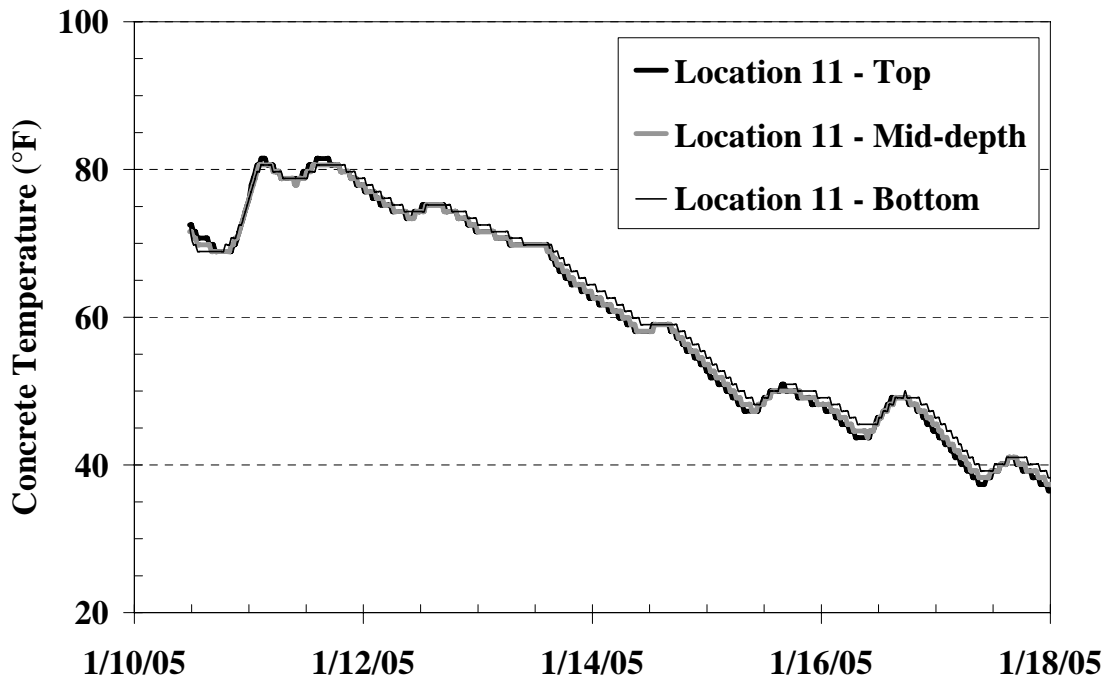

Figure C-63: Temperature history of Location 11 from the I-85 Bridge

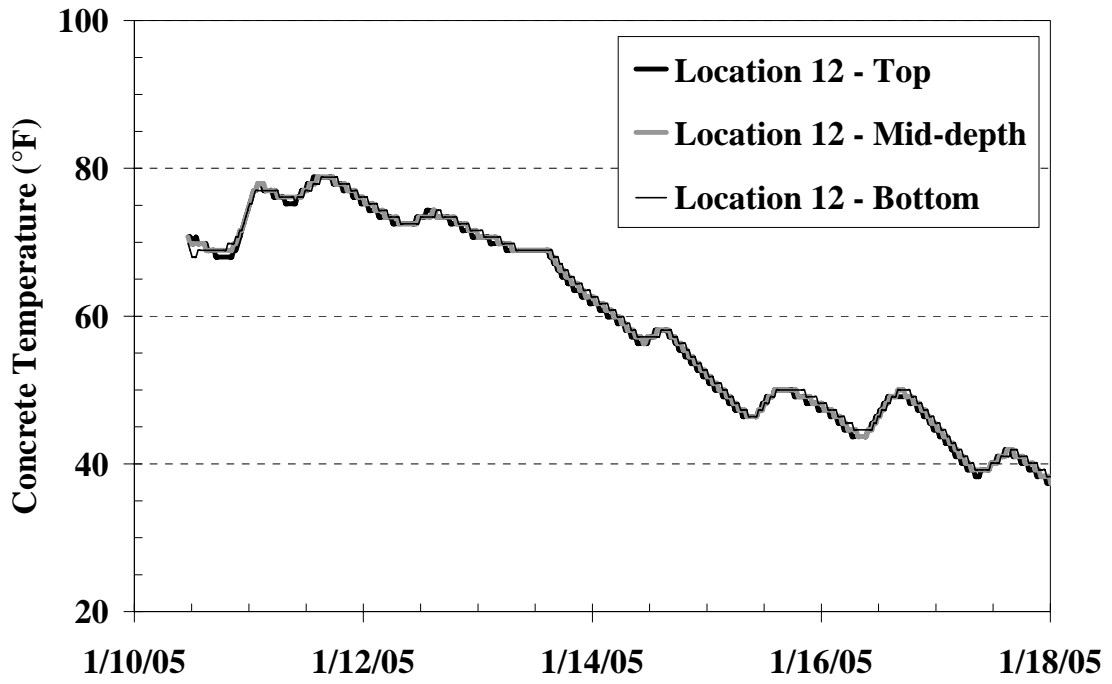

Figure C-64: Temperature history of Location 12 from the I-85 Bridge

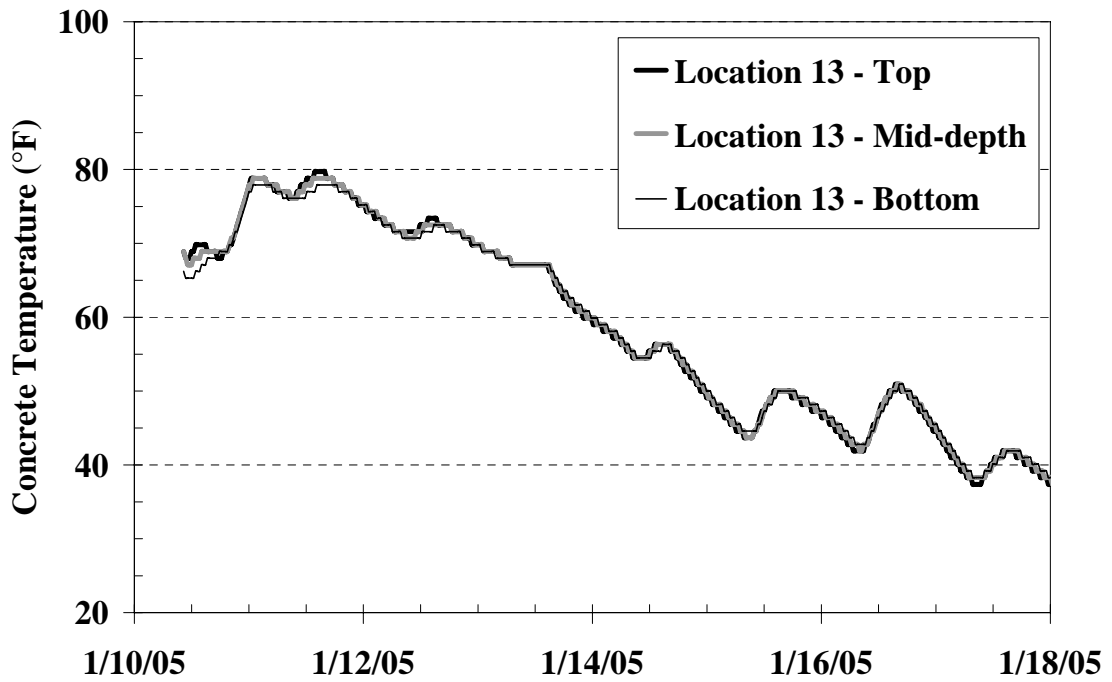

Figure C-65: Temperature history of Location 13 from the I-85 Bridge

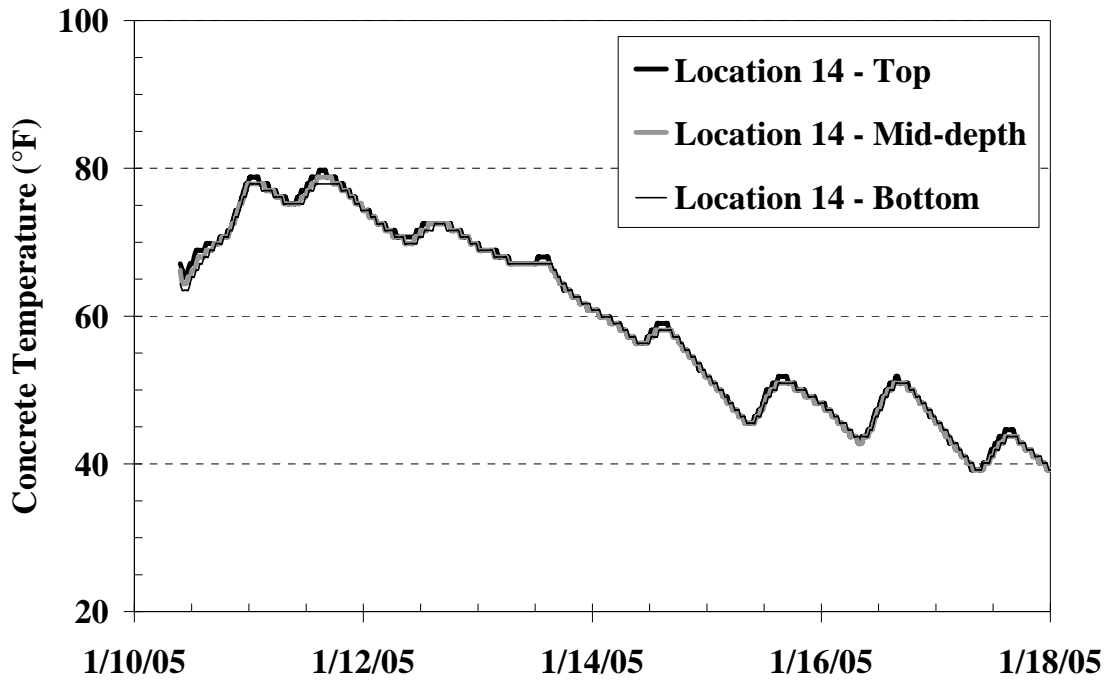

Figure C-66: Temperature history of Location 14 from the I-85 Bridge

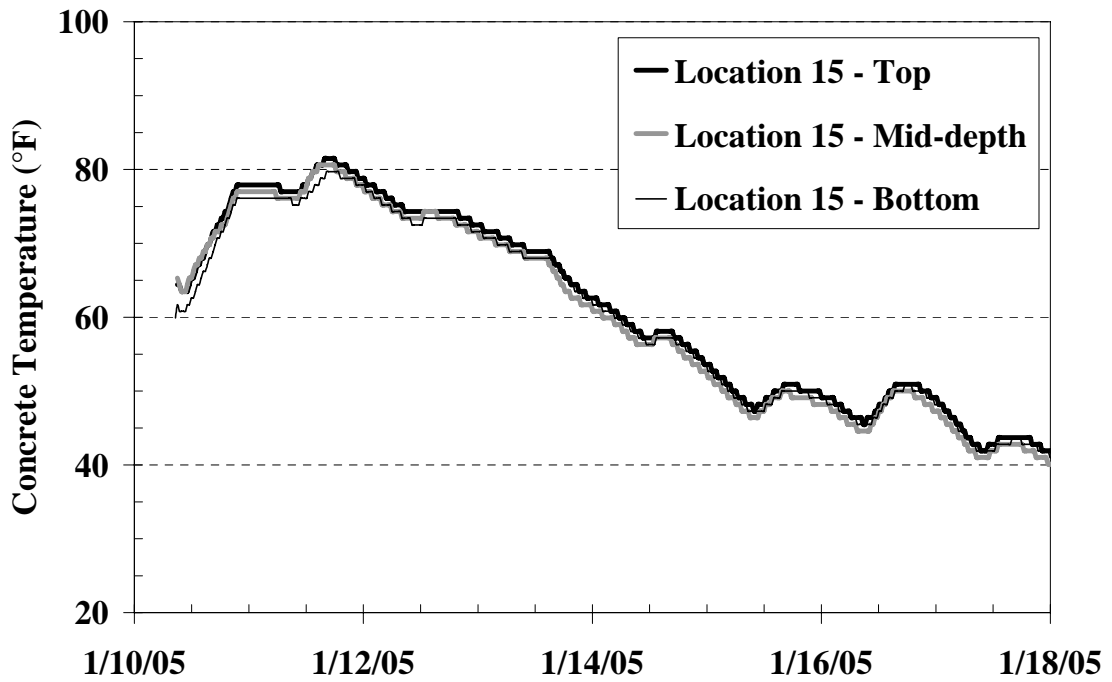

Figure C-67: Temperature history of Location 15 from the I-85 Bridge

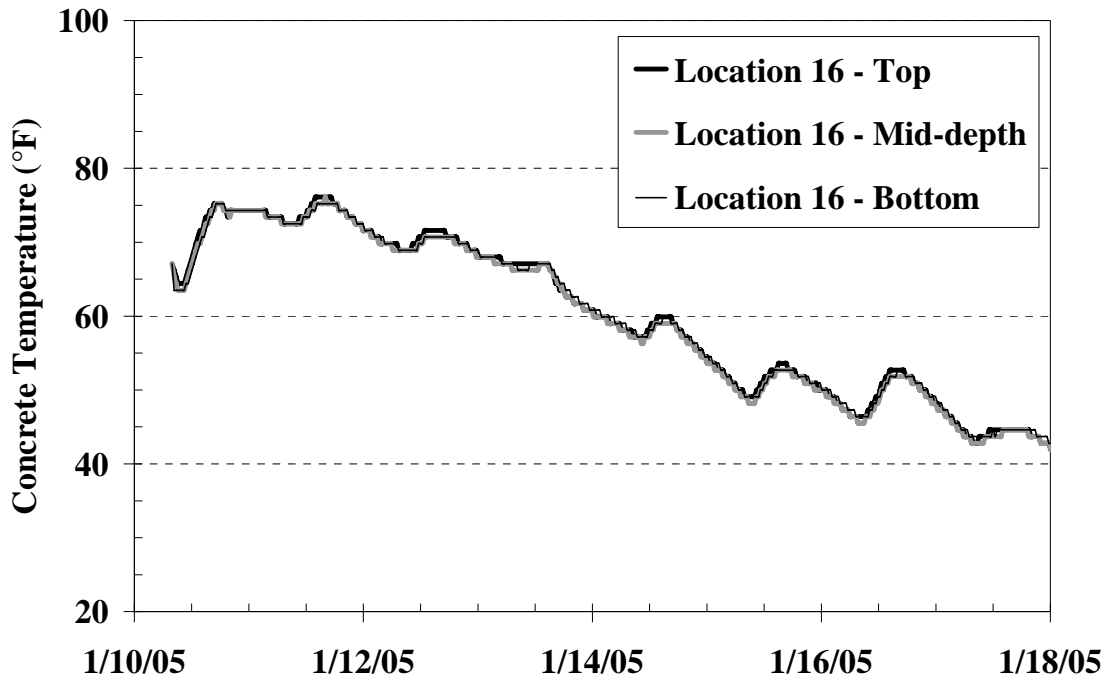

Figure C-68: Temperature history of Location 16 from the I-85 Bridge

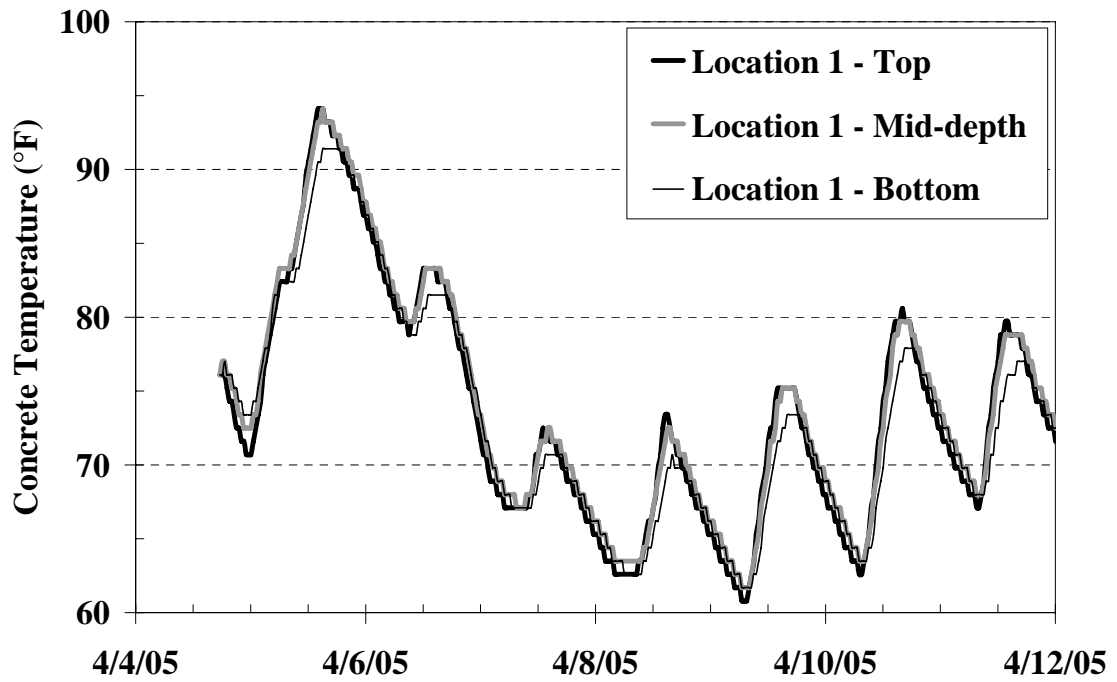

Figure C-69: Temperature history of Location 1 from the Creek Bridge

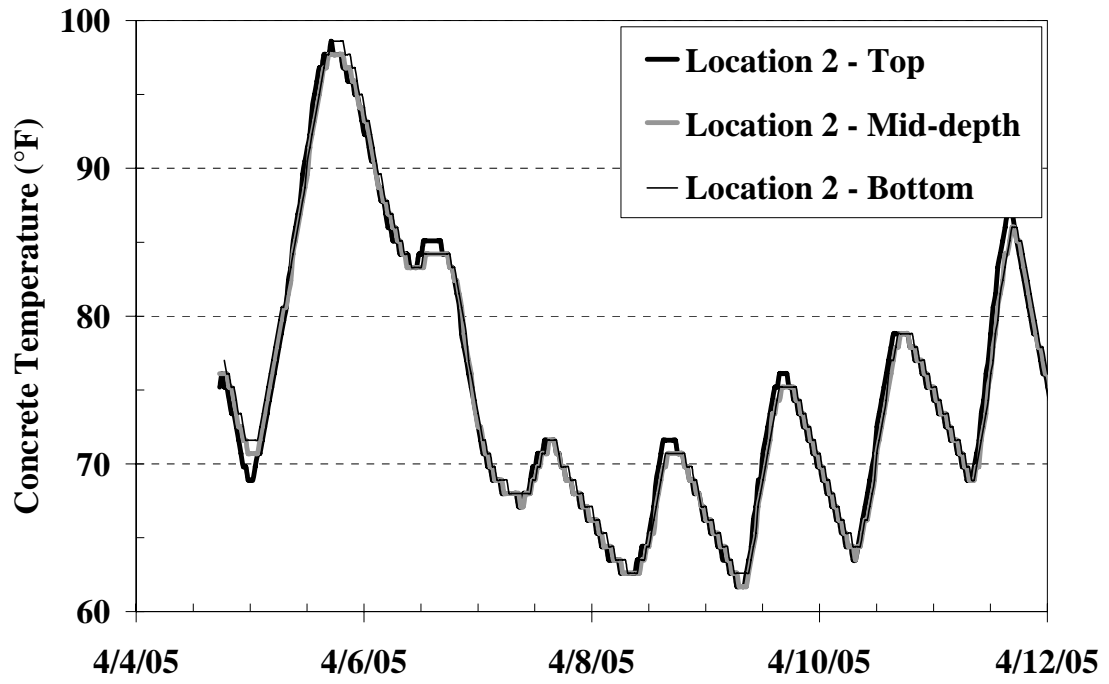

Figure C-70: Temperature history of Location 2 from the Creek Bridge

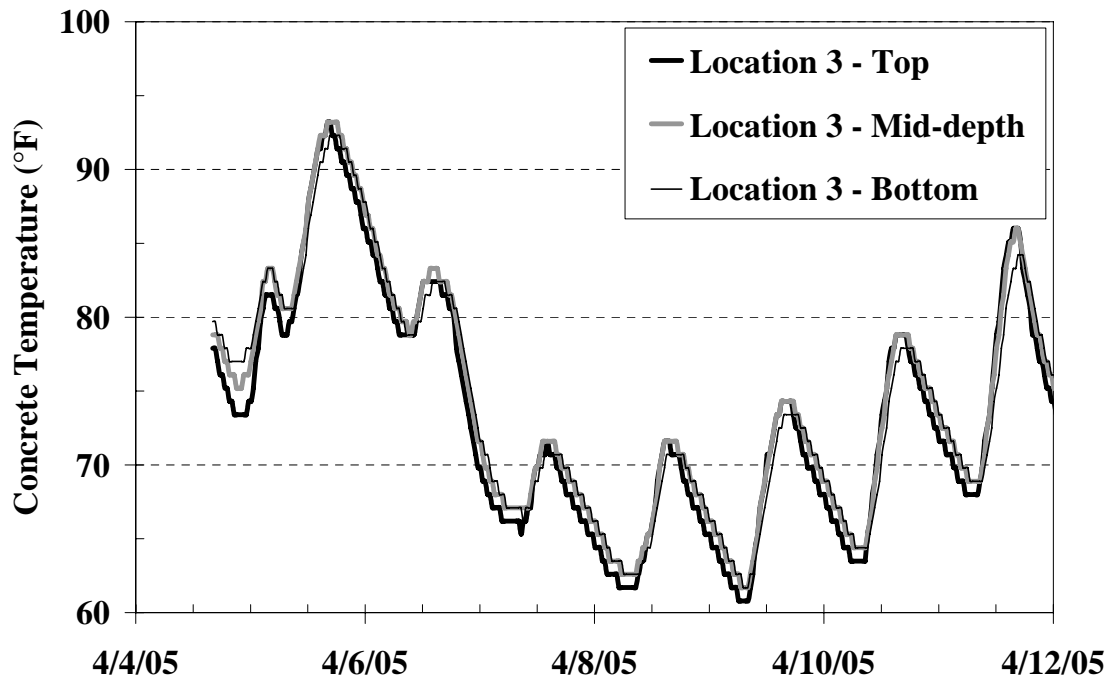

Figure C-71: Temperature history of Location 3 from the Creek Bridge

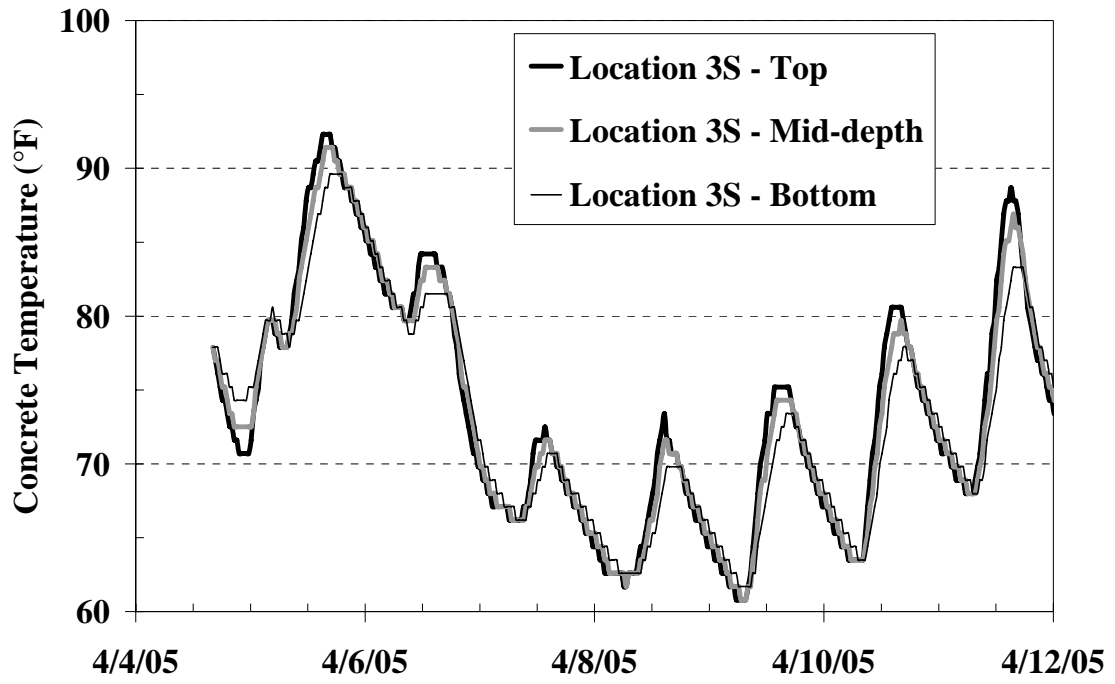

Figure C-72: Temperature history of Location 3S from the Creek Bridge

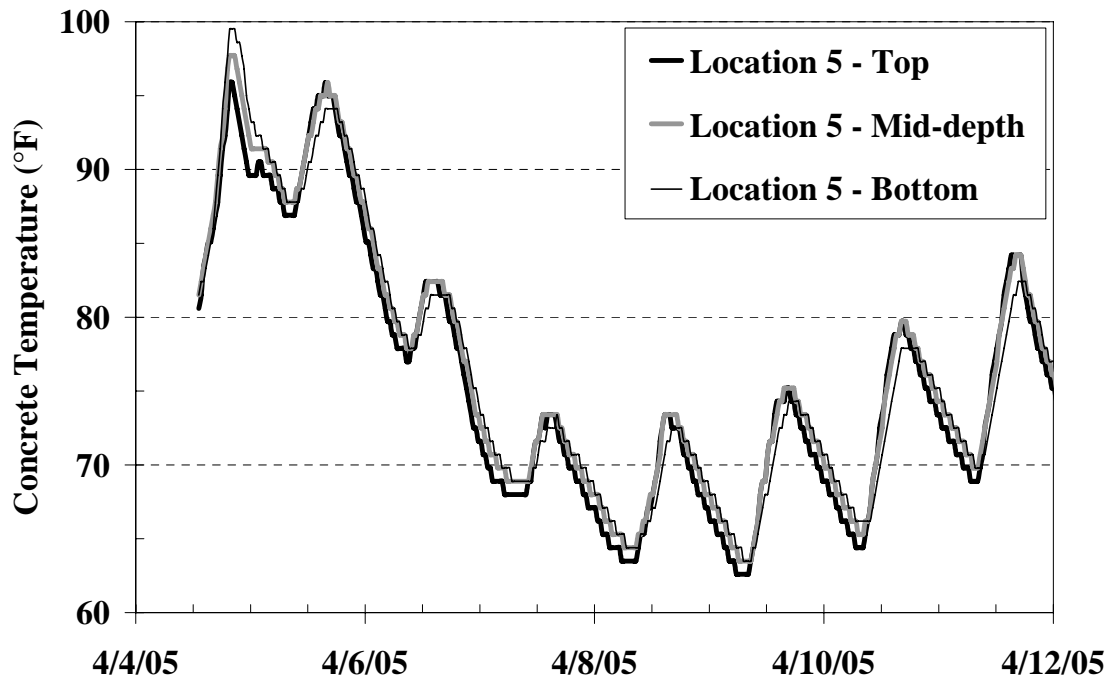

Figure C-73: Temperature history of Location 5 from the Creek Bridge

Table C-49: I-85 Bridge Sample D cylinder strength data

Intended Age (days)	Actual Time Tested	Concrete Age (hours)	Compressive Strength (psi)	% Range
1	1/6/05 7:34 AM	24.0	1,110	2.6
			980	
			990	
2	1/7/05 7:28 AM	47.9	2,210	4.4
			2,270	
			2,180	
3	1/8/05 12:30 PM	77.0	2,880	6.6
			3,040	
			3,080	
4	1/9/05 3:02 PM	103.5	3,460	3.2
			3,520	
			3,570	
7	1/12/05 11:37 AM	172.1	4,080	1.0
			4,070	
			4,030	
14	1/19/05 11:18 AM	339.8	4,890	3.2
			4,740	
			4,820	
28	2/2/05 4:10 PM	680.6	5,640	4.0
			5,870	
			5,790	

Table C-50: Creek Bridge Sample A cylinder strength data

Intended Age (days)	Actual Time Tested	Concrete Age (hours)	Compressive Strength (psi)	% Range
1	4/5/05 1:55 PM	24.6	1,820	1.7
			1,840	
			1,850	
2	4/6/05 1:50 PM	48.5	2,810	6.3
			2,980	
			2,800	
3	-	-	-	-
			-	
			-	
4	4/8/05 11:00 AM	93.7	3,680	4.9
			3,500	
			3,660	
7	4/11/05 2:17 PM	168.9	4,060	2.4
			4,150	
			4,050	
14	4/18/05 10:17 AM	333.0	4,900	2.1
			5,010	
			*	
28	5/2/05 9:37 AM	668.3	6,030	4.9
			5,960	
			5,740	

- 3 day test results were not valid due to complication with the testing machine

* Indicates cylinder data removed due to outliers

Table C-51: I-85 Bridge Verification Test cylinder strength data

Sample	Target	Actual Time Tested	Concrete Age (hours)	Compressive Strength (psi)	% Range
I-85 A	2,400 psi	12/22/04 6:05 PM	31.8	1,750	4.1
				1,700	
				1,770	
	7 Day	12/28/04 10:41 AM	168.4	3,510	4.9
				3,690	
				3,600	
I-85 B	2,400 psi	12/22/04 5:05 PM	32.8	1,570	2.6
				1,590	
				1,550	
	7 Day	12/28/04 10:26 AM	170.1	3,630	2.4
				3,550	
				3,560	
I-85 C	2,400 psi	1/7/05 8:03 AM	43.9	2,060	1.7
				2,030	
				2,060	
	7 Day	1/12/05 11:15 AM	167.1	3,510	2.4
				3,500	
				3,590	

Table C-52: Creek Bridge Verification Test cylinder strength data

Sample	Target	Actual Time Tested	Concrete Age (hours)	Compressive Strength (psi)	% Range
Creek B	2,400 psi	4/6/05 2:25 PM	47.4	2,890	5.8
				2,770	
				2,730	
	7 Day	4/11/05 2:30 PM	167.5	4,480	4.5
				4,310	
				4,280	
Creek C	2,400 psi	4/6/05 5:35 PM	47.9	2,350	2.9
				2,420	
				2,410	
	7 Day	4/11/05 3:35 PM	165.9	3,700	0.9
				3,670	
				3,700	

The following tables and figures are the best-fit exponential function values for the strength-maturity relationships, the estimated cylinder strength data from the all maturity functions, and the S-M relationships for the I-85 Bridge deck cylinders with all the verification cylinders using the Nurse-Saul maturity function with $T_0 = -10\text{ }^\circ\text{C}$ and Arrhenius maturity function with $E = 40\text{ kJ/mol}$.

Table C-53: Strength-maturity relationship exponential function values for the I-85 and Creek Bridge S-M relationships

	<i>Exponential Value</i>	<i>Concrete Age</i>	<i>Nurse-Saul Function</i>		<i>Arrhenius Function</i>	
			$T_o = -10\text{ }^\circ\text{C}$	$T_o = 0\text{ }^\circ\text{C}$	E = 33,500 J/mol	E = 40,000 J/mol
<i>I-85 and US 29 Bridge</i>	S_u (psi)	6,952	7,099	7,180	7,159	7,202
	β	0.6475	0.6127	0.5958	0.6004	0.5919
	τ	61.2851	1873.4775	1265.8544	55.5277	54.5971
	R^2	0.99	0.99	0.99	0.99	0.99
<i>Creek Bridge</i>	S_u (psi)	10,827	9,676	9,291	8,946	8,946
	β	0.3076	0.3645	0.3911	0.4199	0.4199
	τ	139.4589	3217.9646	2008.4992	81.4724	81.4710
	R^2	0.99	0.99	0.99	0.99	0.99

Table C-54: Estimated strength for the verification test using the *I-85 Bridge* S-M relationship (psi)

Cylinder Set	Target	Measured Strength (psi)	Nurse-Saul Function		Arrhenius Function	
			$T_o = -10\text{ }^\circ\text{C}$	$T_o = 0\text{ }^\circ\text{C}$	E = 33.5 kJ/mol	E = 40 kJ/mol
I-85 A	2,400 psi	1,740	1,720	1,830	1,820	1,890
	7 Day	3,600	4,140	4,140	4,120	4,170
I-85 B	2,400 psi	1,570	1,750	1,840	1,840	1,900
	7 Day	3,580	4,140	4,140	4,140	4,140
I-85 C	2,400 psi	2,050	2,200	2,280	2,280	2,330
	7 Day	3,530	4,150	4,170	4,170	4,180
Creek B	2,400 psi	2,800	2,330	2,420	2,420	2,470
	7 Day	4,360	4,180	4,200	4,200	4,210
Creek C	2,400 psi	2,390	2,330	2,410	2,410	2,450
	7 Day	3,690	4,150	4,170	4,150	4,200

Table C-55: Sample I-85 D and Creek A estimated strengths using I-85 cylinders S-M relationship (psi)

	Concrete Age (hours)	Measured Strength (psi)	Nurse-Saul Function		Arrhenius Function	
			T _o = -10 °C	T _o = 0 °C	E = 33.5 kJ/mol	E = 40 kJ/mol
<i>I-85 Bridge Sample D Cylinders</i>	24.0	1,000	1,110	1,100	1,100	1,100
	47.9	2,220	2,150	2,150	2,150	2,150
	77.0	3,000	2,940	2,950	2,950	2,950
	103.5	3,520	3,410	3,410	3,410	3,410
	172.1	4,060	4,160	4,160	4,160	4,160
	339.8	4,820	4,990	4,990	4,990	4,990
	680.6	5,770	5,630	5,640	5,640	5,640
<i>Creek Bridge Sample A Cylinders</i>	24.6	1,840	1,490	1,650	1,720	1,770
	48.5	2,860	2,410	2,520	2,560	2,600
	-	-	-	-	-	-
	93.7	3,610	3,380	3,440	3,450	3,490
	168.9	4,090	4,190	4,230	4,220	4,250
	333.0	4,950	5,000	5,020	5,010	5,030
	668.3	5,910	5,650	5,670	5,660	5,680

- 3 day test results were not valid due to complication with the testing machine

C.4 ACCURACY OF THE MATURITY METHOD RESULTS

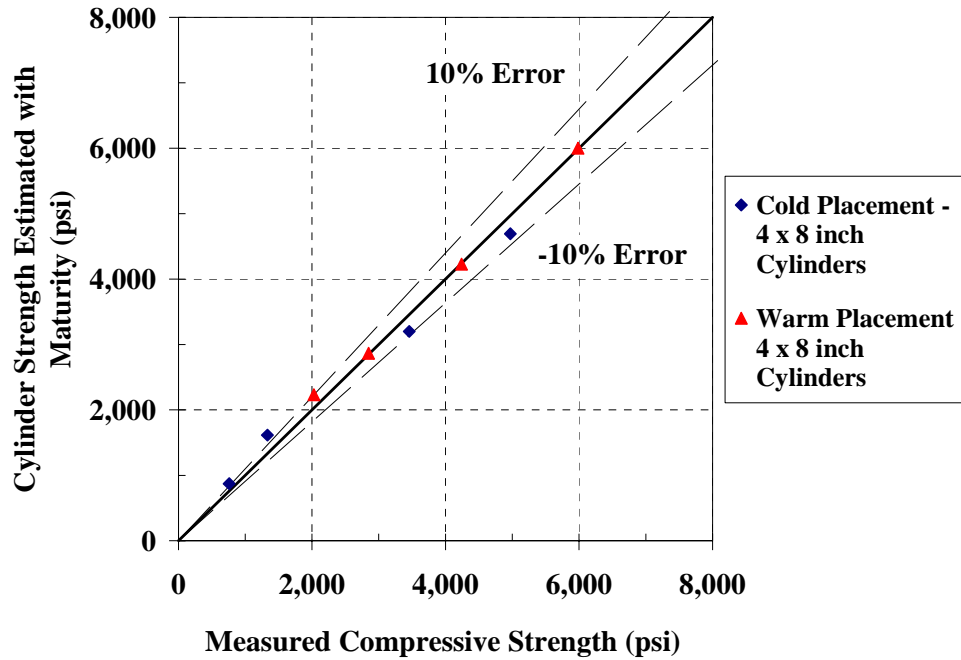

Figure C-74: 45°-line graph for estimating the strength of water-tank-cured 4 x 8 inch cylinder from the mock bridge deck *laboratory* S-M relationships using the Nurse-Saul maturity function ($T_o = -10\text{ }^\circ\text{C}$)

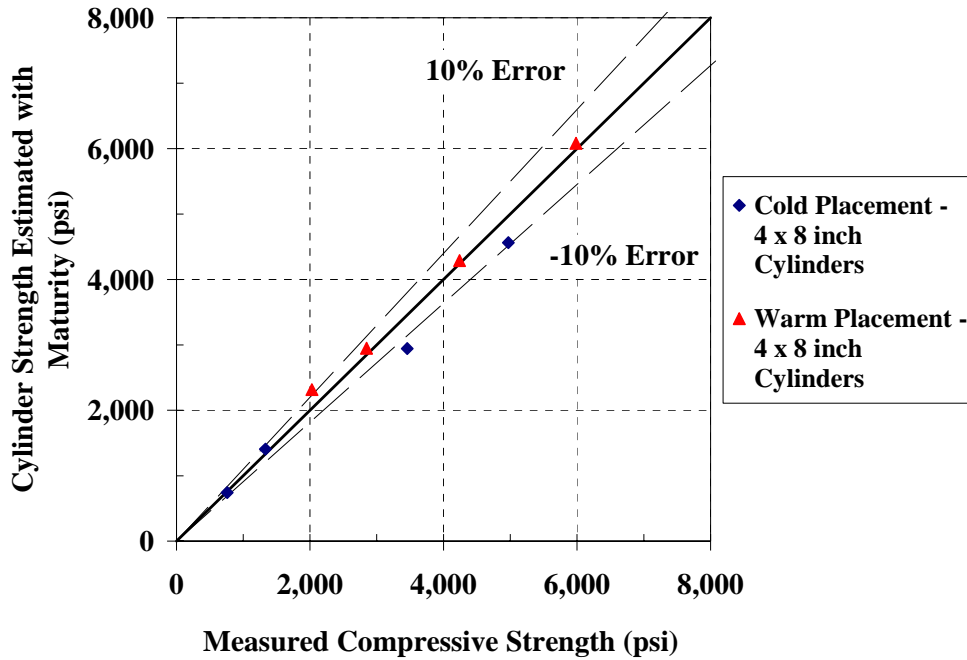

Figure C-75: 45°-line graph for estimating the strength of water-tank-cured 4 x 8 inch cylinder from the mock bridge deck *laboratory* S-M relationships using the Arrhenius maturity function ($E = 40 \text{ kJ/mol}$)

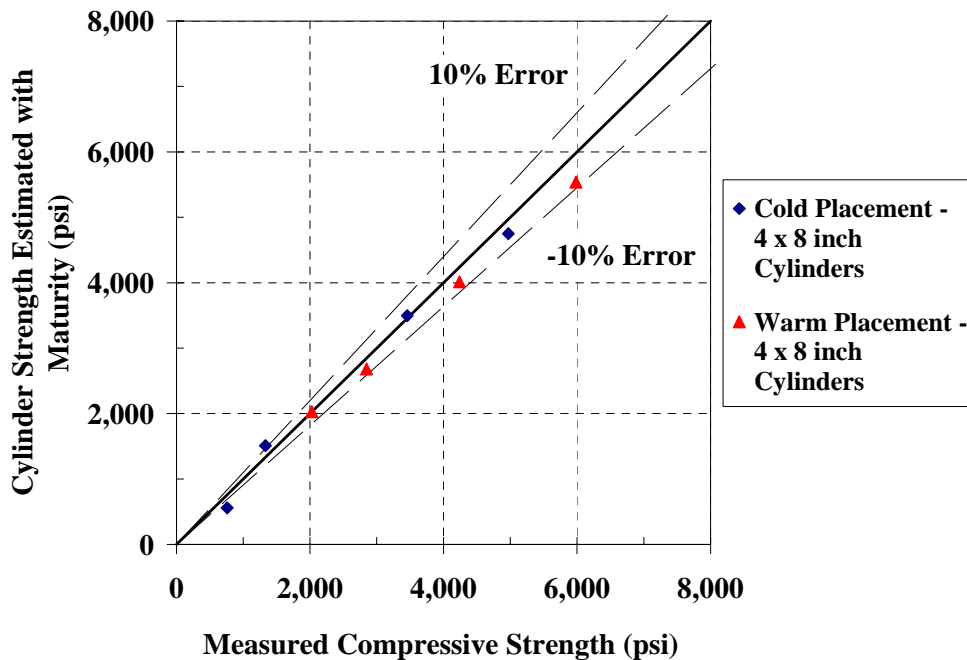

Figure C-76: 45°-line graph for estimating the strength of water-tank-cured 4 x 8 inch cylinder from the mock bridge deck *water-tank* S-M relationships using the Nurse-Saul maturity function ($T_0 = -10 \text{ }^\circ\text{C}$)

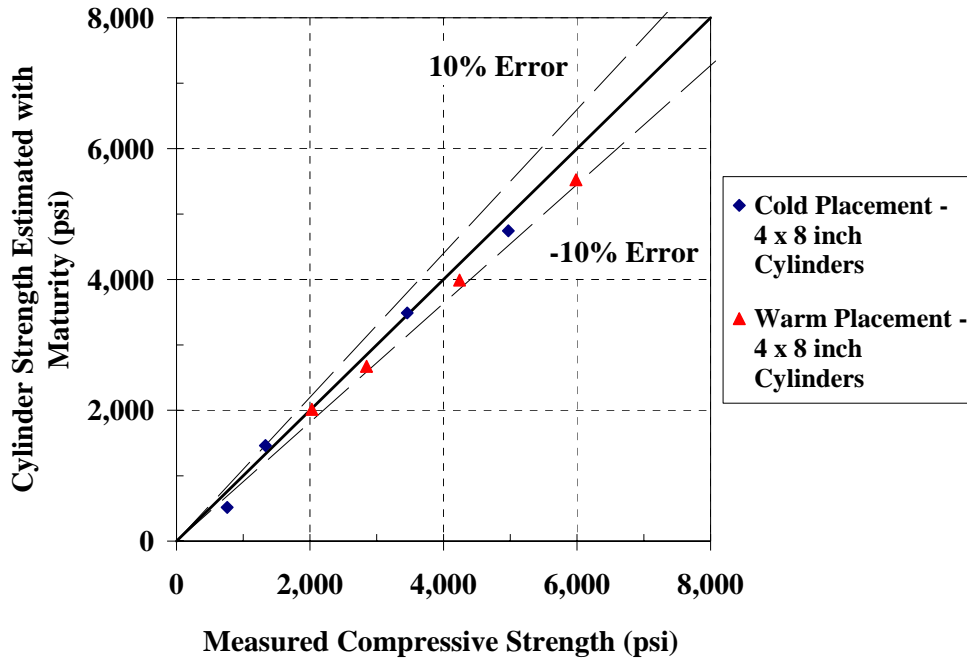

Figure C-77: 45°-line graph for estimating the strength of water-tank-cured 4 x 8 inch cylinder from the mock bridge deck *water-tank* S-M relationships using the Arrhenius maturity function ($E = 40 \text{ kJ/mol}$)

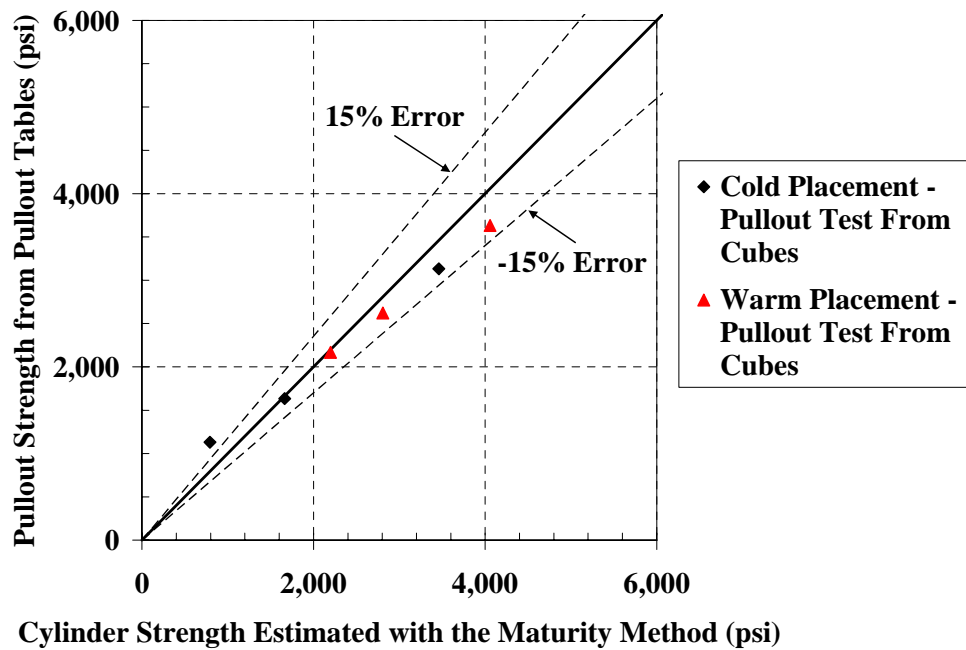

Figure C-78: 45°-line graph to evaluate the pullout table using estimated strength from *water-tank* S-M relationship using the Nurse-Saul maturity function ($T_0 = -10 \text{ }^\circ\text{C}$)

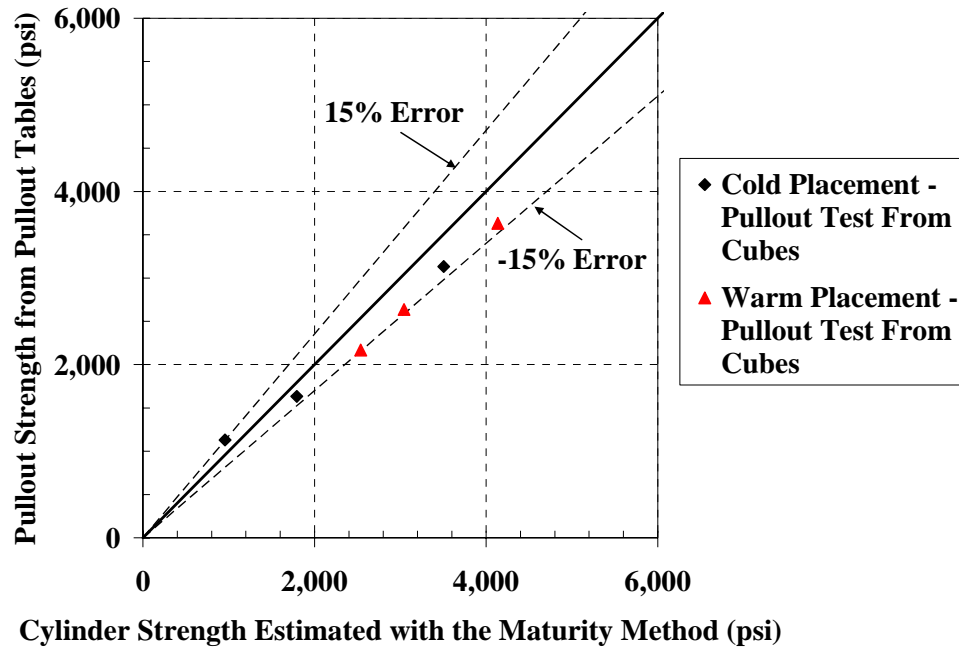

Figure C-79: 45°-line graph to evaluate the pullout table using estimated strength from *water-tank* S-M relationship using the Arrhenius maturity function ($E = 40 \text{ kJ/mol}$)

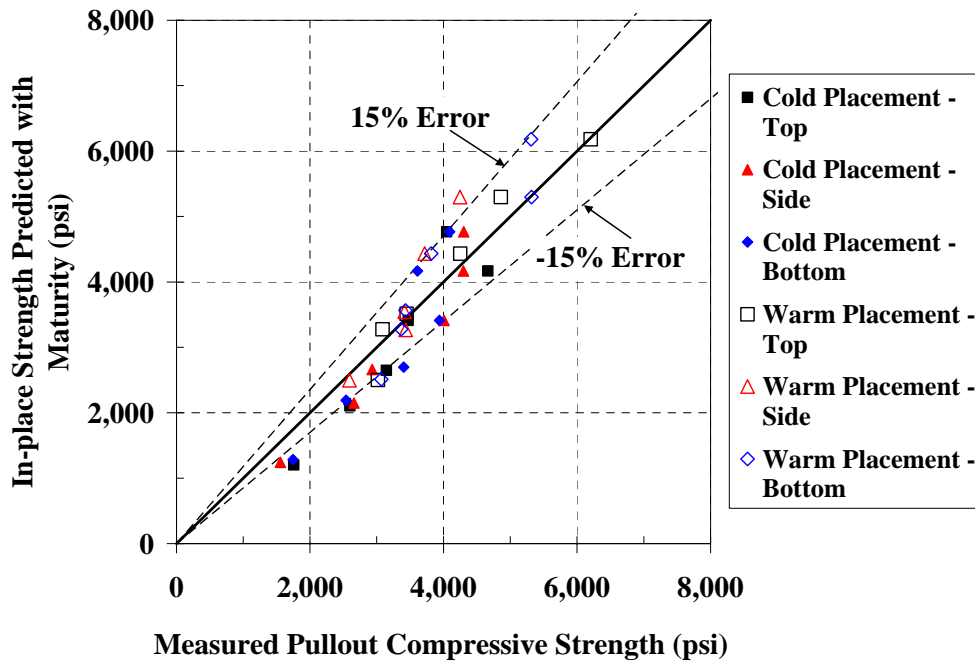

Figure C-80: 45°-line graph for estimating the strength of pullout test on the mock bridge deck using *laboratory* S-M relationship with Nurse-Saul maturity function ($T_0 = -10 \text{ }^\circ\text{C}$)

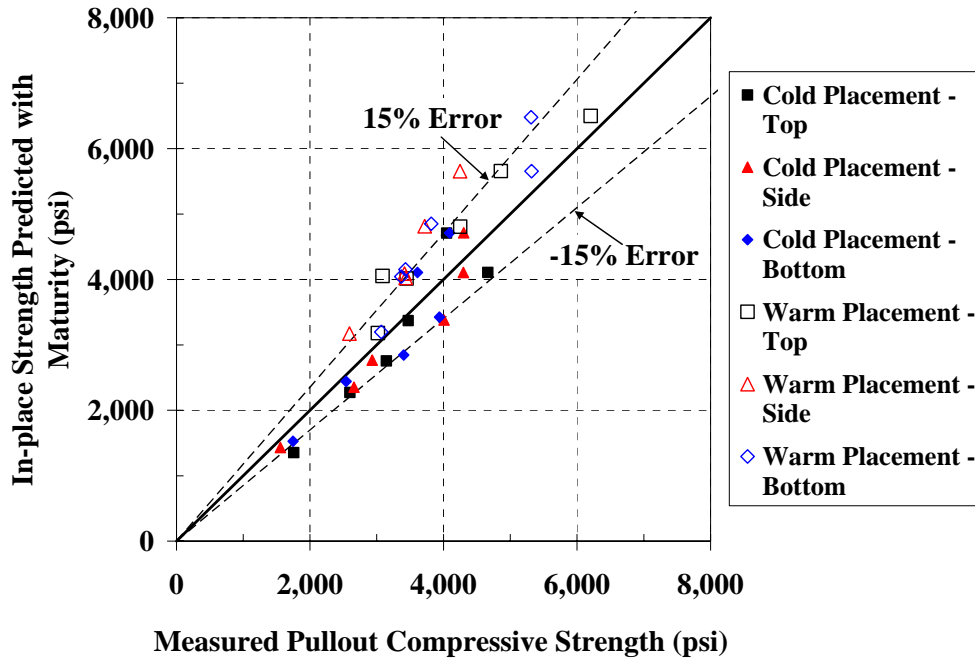

Figure C-81: 45°-line graph for estimating the strength of pullout test on the mock bridge deck using *laboratory* S-M relationship with Arrhenius maturity function ($E = 40 \text{ kJ/mol}$)

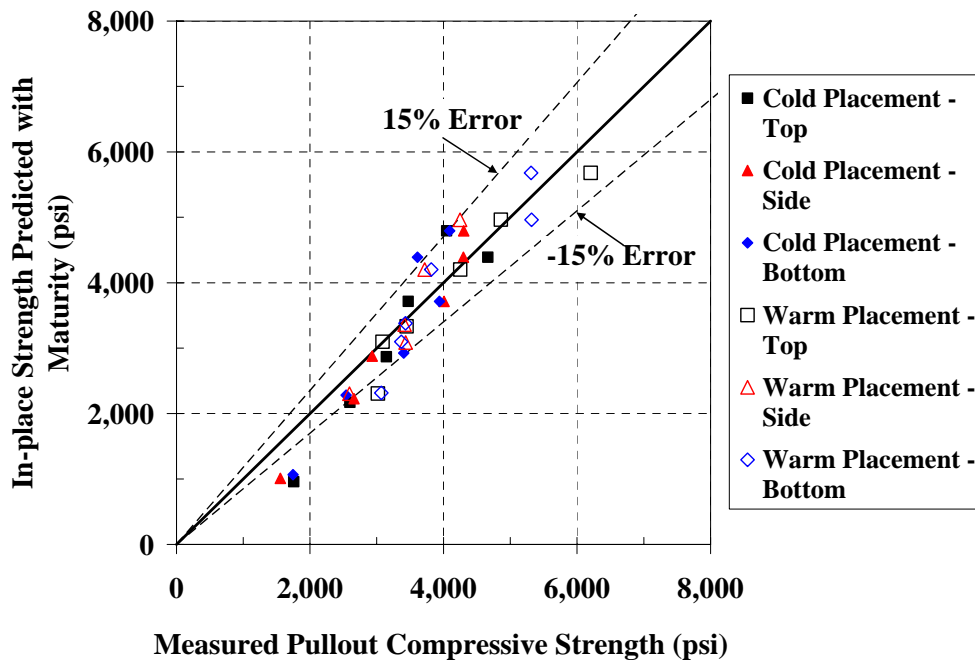

Figure C-82: 45°-line graph for estimating the strength of pullout test on the mock bridge deck using *water-tank* S-M relationship with Nurse-Saul maturity function ($T_0 = -10 \text{ }^\circ\text{C}$)

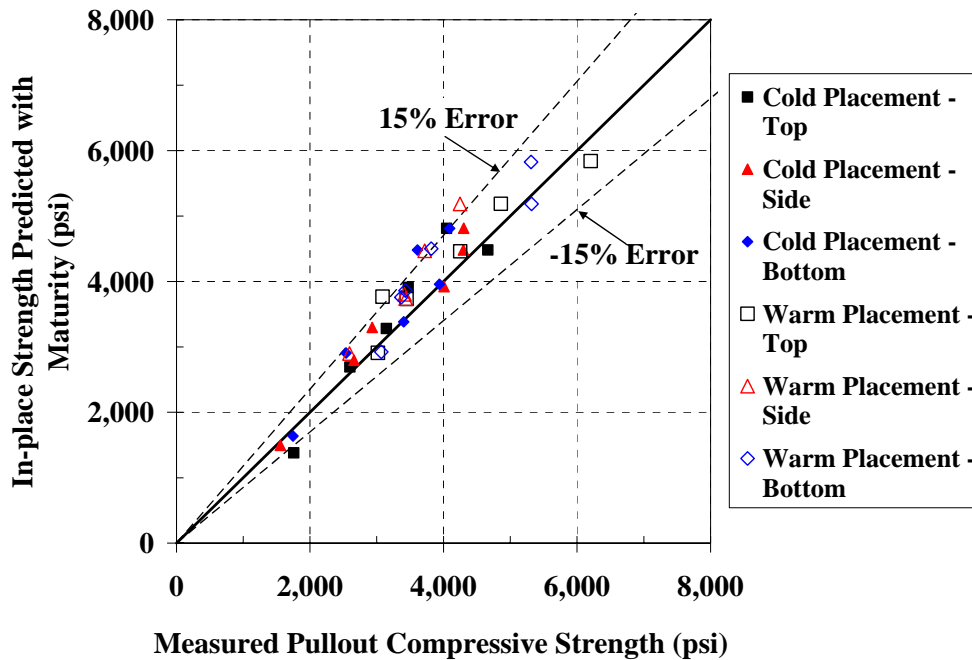

Figure C-83: 45°-line graph for estimating the strength of pullout test on the mock bridge deck using *water-tank* S-M relationship with Arrhenius maturity function ($E = 40 \text{ kJ/mol}$)

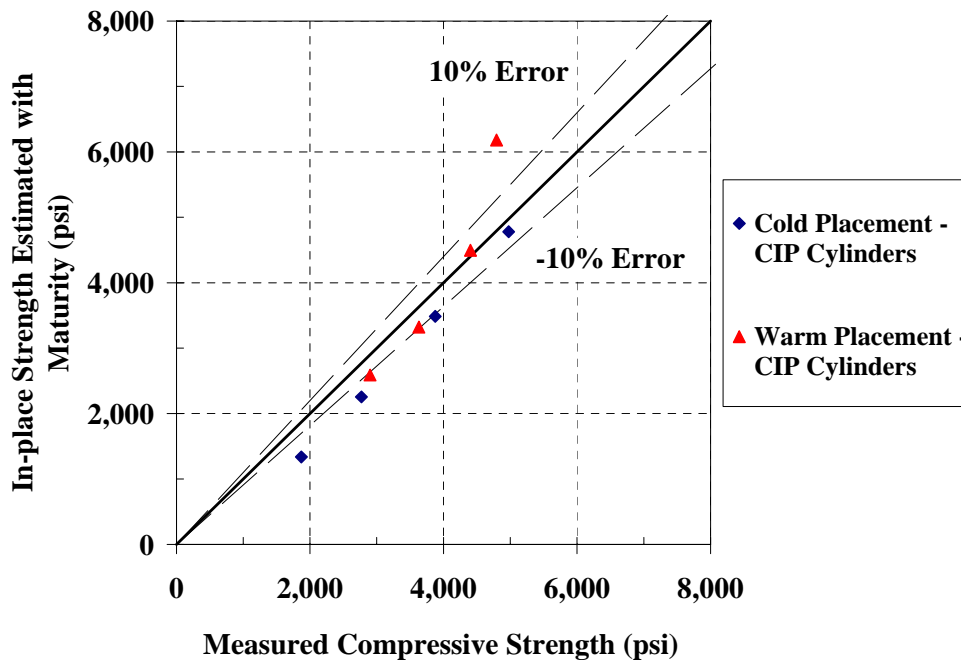

Figure C-84: 45°-line graph for estimating the strength of CIP cylinders on the mock bridge deck using *Laboratory* S-M relationship with Nurse-Saul maturity function ($T_0 = -10 \text{ }^\circ\text{C}$)

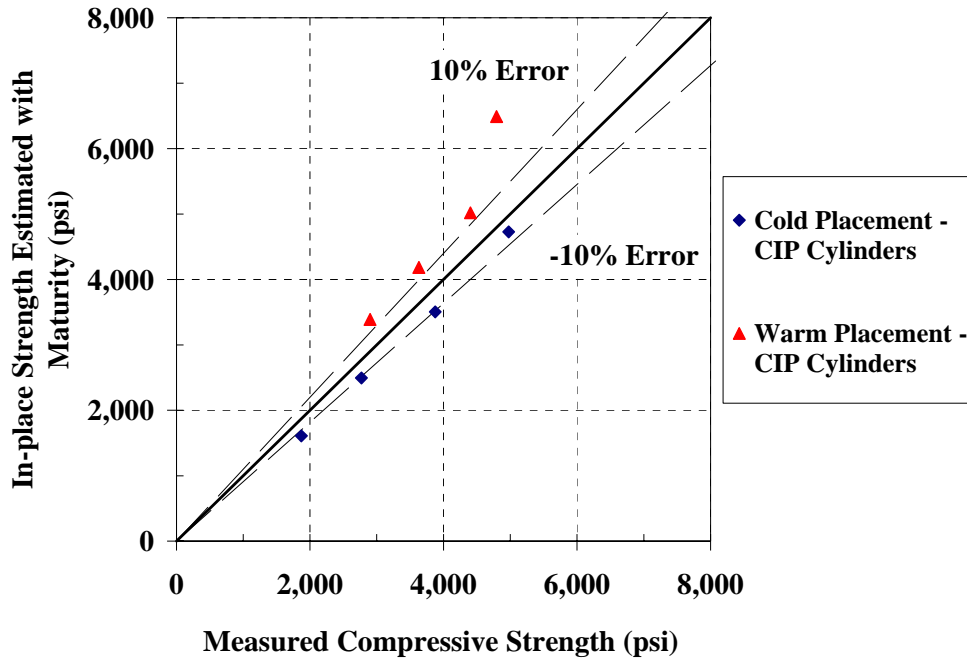

Figure C-85: 45°-line graph for estimating the strength of CIP cylinders on the mock bridge deck using *Laboratory S-M* relationship with Arrhenius maturity function ($E = 40 \text{ kJ/mol}$)

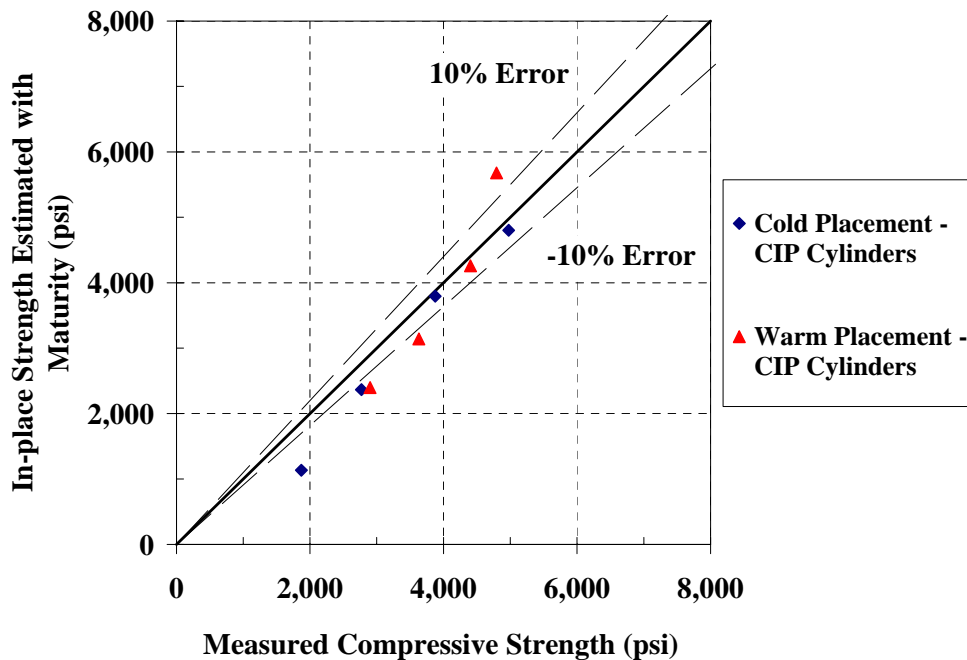

Figure C-86: 45°-line graph for estimating the strength of CIP cylinders on the mock bridge deck using *water-tank S-M* relationship with Nurse-Saul maturity function ($T_0 = -10 \text{ }^\circ\text{C}$)

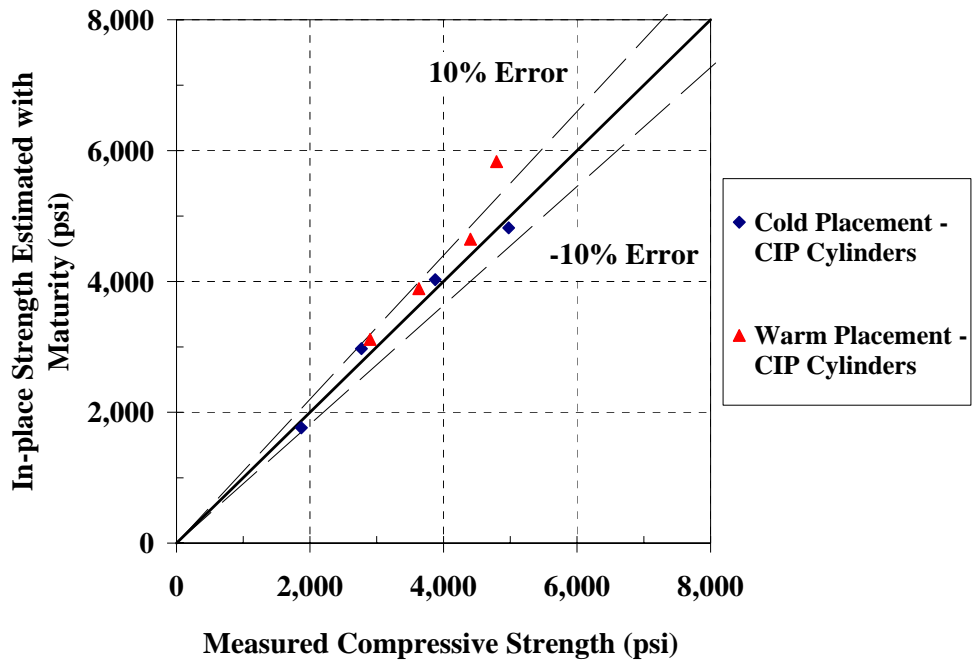

Figure C-87: 45°-line graph for estimating the strength of CIP cylinders on the mock bridge deck using *water-tank* S-M relationship with Arrhenius maturity function ($E = 40 \text{ kJ/mol}$)

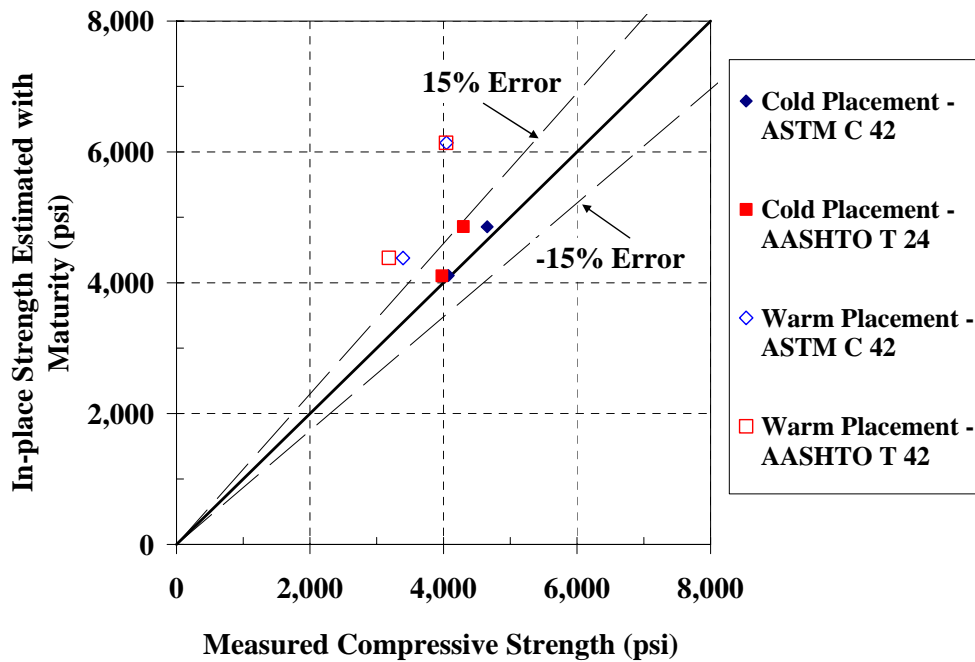

Figure C-88: 45°-line graph for estimating the strength of cores for the mock bridge deck using *laboratory* S-M relationship with Nurse-Saul maturity function ($T_0 = -10 \text{ }^\circ\text{C}$)

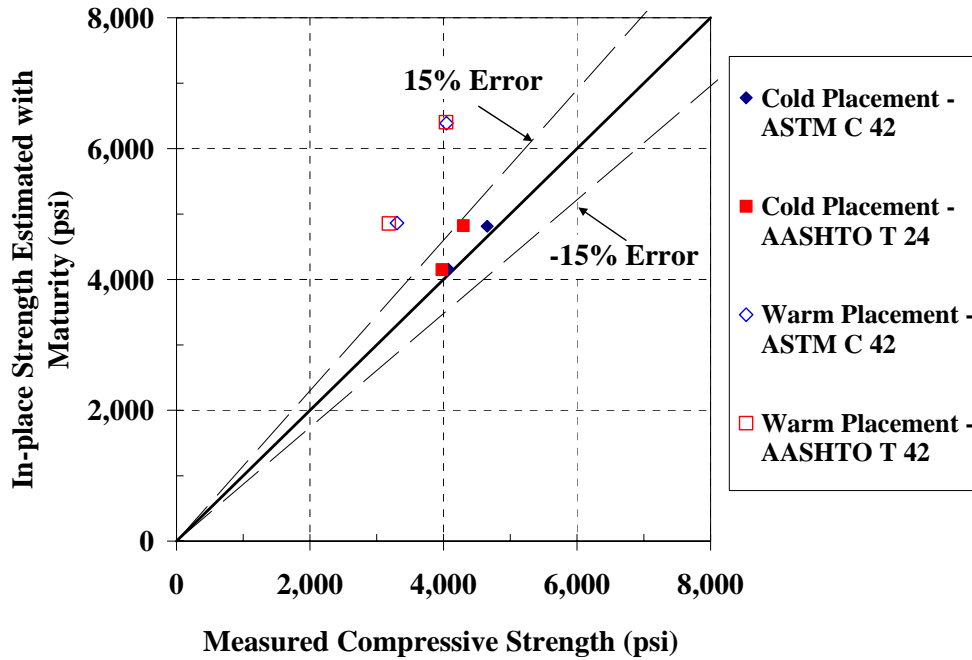

Figure C-89: 45°-line graph for estimating the strength of cores for the mock bridge deck using *laboratory S-M* relationship with Arrhenius maturity function ($E = 40 \text{ kJ/mol}$)

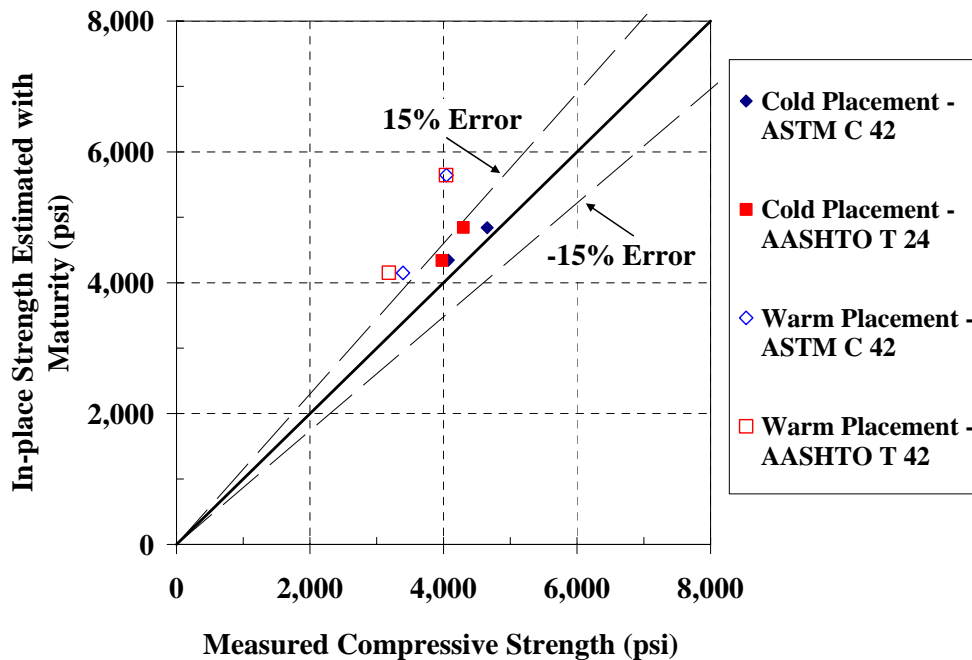

Figure C-90: 45°-line graph for estimating the strength of cores for the mock bridge deck using *water-tank S-M* relationship with Nurse-Saul maturity function ($T_0 = -10 \text{ }^\circ\text{C}$)

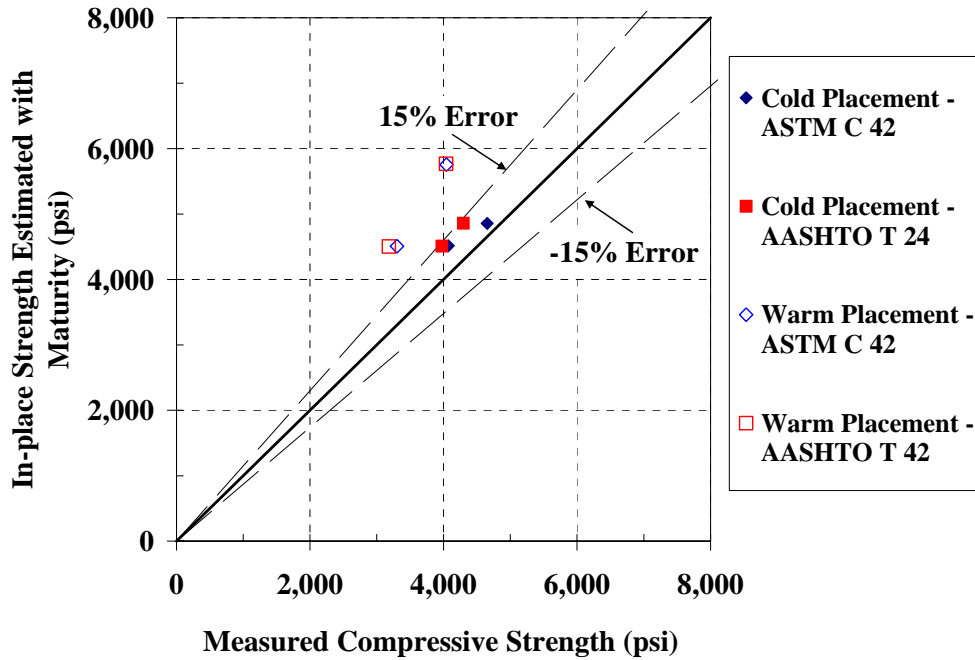

Figure C-91: 45°-line graph for estimating the strength of cores for the mock bridge deck using *water-tank* S-M relationship with Arrhenius maturity function ($E = 40 \text{ kJ/mol}$)

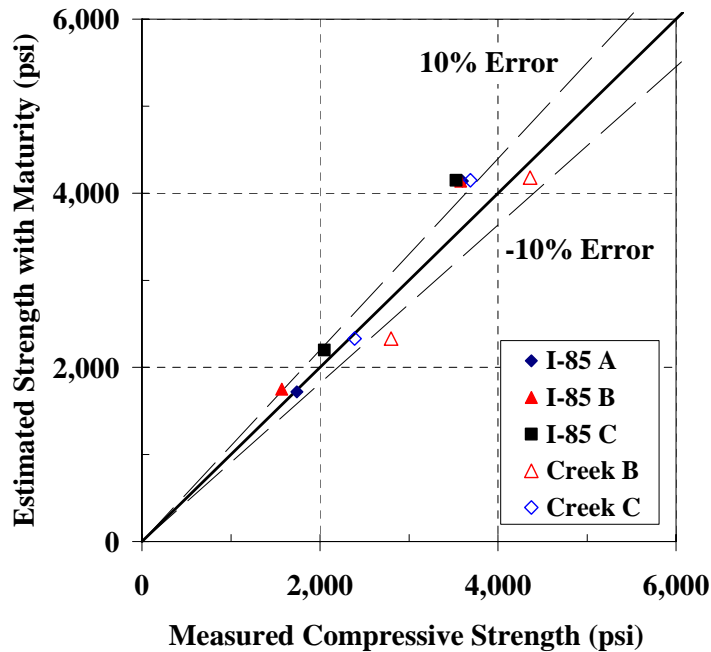

Figure C-92: 45°-line graph for estimating the strength of the verification cylinders using *I-85 Bridge* S-M relationship with Nurse-Saul maturity function ($T_o = -10 \text{ }^\circ\text{C}$)

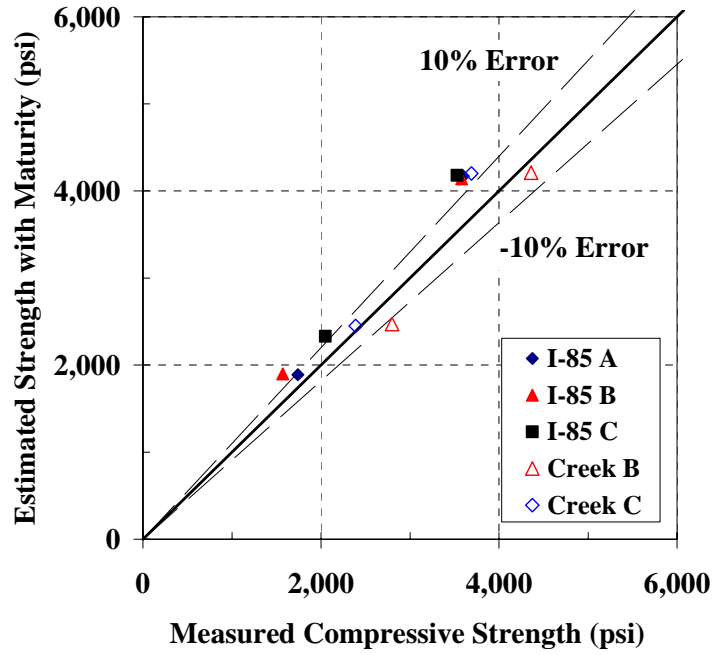

Figure C-93: 45°-line graph for estimating the strength of the verification cylinders using *I-85 Bridge* S-M relationship with Arrhenius maturity function ($E = 40$ kJ/mol)

C.5 PICTURES OF THE MOCK BRIDGE DECK



Figure C-94: Mock bridge deck base slab reinforcement



Figure C-95: Mock bridge deck base slab



Figure C-96: Mock bridge deck



Figure C-97: Mock bridge deck in-place testing and reinforcement



Figure C-98: Cast-in-place cylinders and pullout inserts



Figure C-99: Cast-in-place cylinders and pullout inserts (2)



Figure C-100: Side and bottom pullout inserts



Figure C-101: Cast-in-place cylinder with 4 x 8 plastic mold



Figure C-102: Mock bridge deck in-place testing and iButtons



Figure C-103: iButton stands to measure concrete temperatures



Figure C-104: Sam Wade conducting slump test



Figure C-105: Fresh concrete testing area



Figure C-106: Installing top pullout inserts



Figure C-107: Top pullout inserts



Figure C-108: Top pullout inserts (2)



Figure C-109: Field-cured specimens storage area for the first 24 hours



Figure C-110: Coring mock bridge deck



Figure C-111: Pullout testing of top inserts on mock bridge deck



Figure C-112: Bottom view of cast-in-place cylinder and cores for mock bridge deck



Figure C-113: Bottom pullout inserts and cast-in-place cylinder for mock bridge deck



Figure C-114: Bottom pullout inserts for mock bridge deck



Figure C-115: Bottom pullout inserts for mock bridge deck (2)



Figure C-116: Side pullout test for mock bridge deck

C.6 PICTURES OF THE EVALUATION ASTM C 1074



Figure C-117: iButtons suspended between reinforcement



Figure C-118: iButtons suspended between reinforcement (2)



Figure C-119: iButtons suspended between reinforcement (3)



Figure C-120: iButtons attached to reinforcement



Figure C-121: iButtons on overhang of the Creek Bridge



(a)



(b)

Figure C-122: (a) iButtons in the middle of bridge deck and (b) iButtons at edge of bridge deck



Figure C-123: iButton wire with phone jack secured to the barrier wall reinforcement



Figure C-124: iButton wire with phone jack secured to the barrier wall reinforcement (2)



Figure C-125: iButton wire with phone jack secured to the barrier wall reinforcement (3)



Figure C-126: Placing concrete in Pour 1 of I-85 Bridge deck



Figure C-127: Placing concrete in Pour 1 of I-85 Bridge deck (2)



Figure C-128: Placing concrete in Pour 1 of I-85 Bridge deck (3)

APPENDIX D

PROPOSED ALDOT MATURITY SPECIFICATION

This appendix is the proposed Alabama Department of Transportation specification for implementing the maturity method. The contents of this appendix are only the recommended specification from results concluded for this project conducted by Auburn University researchers. The final maturity specification will be approved and implemented by the Alabama Department of Transportation.

ALABAMA DEPARTMENT OF TRANSPORTATION

DATE: December 23, 2005

Special Provision No. 05-XXX

SUBJECT: *Estimating Early Age Concrete Strengths with the Maturity Method*

Alabama Standard Specifications, 2002 Edition, are hereby amended as follows:

Description

This test method provides a procedure for estimating early age concrete strengths by means of the maturity method. For a given concrete mixture, which has been properly placed, consolidated, and cured, the maturity method accounts for the effect of age and temperature history on the strength development. It is assumed that concretes with same maturity have equal strength, regardless of their temperature history.

The maturity method consists of the following three steps:

1. Develop the strength-maturity relationship (see Table 1),
2. Estimate the in-place strength (see Table 2), and
3. Verify the strength estimated by the maturity method (see Table 3).

The Nurse-Saul maturity function shall be used to compute the maturity index in terms of a "temperature-time factor (TTF)". A datum temperature of 0 °C (32 °F) shall be used.

$$\text{Nurse-Saul maturity function: } M = \sum_0^t (T_c - T_0) \cdot \Delta t$$

- where,
- M = maturity in time-temperature factor (TTF) units (hr·°C),
 - T_c = the average concrete temperature during the time interval (°C),
 - T₀ = the datum temperature (°C), and
 - Δt = the time interval between temperature measurements (hr).

Apparatus

- Commercial maturity recording devices that automatically compute and display the maturity in terms of a temperature-time factor are acceptable. Acceptable devices include thermocouples connected to digital data-loggers, or embedded digital devices that record and store the data. All devices must be able to transfer the collected data to a computer.
- The maturity recording device shall be able to record the temperature accurately to within ± 1 °C (2 °F).
- The maximum recording intervals shall be every ½ hour for the first 48 hours, and every hour thereafter.
- The same brand and type of maturity recording device shall be used for all testing performed on a specific project.
- A minimum of one maturity recording device shall be provided for each maturity sensor location.
- The maturity recording device shall be protected from theft, damage, and excessive moisture.
- If the maturity recording device has input capability for datum temperature, verify that a value of 0 °C (32 °F) has been selected prior to each use.
- If applicable, batteries in maturity devices are to be adequately charged prior to use.

Table 1: Procedure to Develop the Strength-Maturity Relationship

Step	Action																																									
1	For pavement and bridge construction applications, prepare a minimum of 16 cylinders. For precast prestressed applications, prepare a minimum of 19 cylinders. The mixture proportions and constituents of the concrete shall be the same as those of the job concrete whose strength will be estimated using this specification. The minimum batch size of three (3) cubic yards shall be used to produce the concrete to establish the strength-maturity relationship.																																									
2	Fresh concrete testing for each batch shall include concrete placement temperature, slump, and air content.																																									
3	Embed two (2) maturity sensors in one of the cylinders. Maturity sensors shall be positioned close the center of the cylinders. As soon as practical after concrete placement, activate the recording device(s) to start record the maturity. Do not stop recording until the required maturity values are achieved. Data collection must be uninterrupted. The cylinder instrumented with maturity sensors shall not be used for strength testing.																																									
4	<p>All cylinders shall be cured in the field under conditions that reflect the exposure condition of the structure. Initial curing of the cylinders may last up to 48 hours. During the initial curing period for pavement and bridge construction applications, cylinders are to remain capped with plastic lids while exposed to ambient temperature conditions, direct sunlight, and a vibration free environment. During the initial curing period for precast prestressed applications, cylinders should be capped with plastic lids, positioned next to the prestressed member, and cured the same as the girder. After 24 hours, cylinders are to be removed from the molds and within 30 minutes immersed in a calcium hydroxide saturated water storage tank until prior to transportation to the testing laboratory. The water tank must be exposed to ambient temperature conditions, direct sun light, and a vibration free environment. The water level must be maintained above the height of all the cylinders at all times. Should the ambient temperatures drop below 40°F, then the water storage tanks shall be covered with insulation material to prevent freezing of the water.</p> <p>For a period not to exceed 4 hours immediately prior to testing, remove the cylinders from the water tank, and transport and handle them to ensure free water is maintained on all surfaces at all times. Drying of the cylinder surfaces is not allowed at any time. Moisture loss during transportation can be prevented by wrapping the cylinders in plastic, wet burlap, or by surrounding them with wet sand. During transporting, protect the cylinders with suitable cushioning material to prevent damage. During cold weather, protect the cylinders from freezing with suitable insulation material.</p>																																									
5	<p>Testing ages are influenced by the initial ambient temperature that the concrete is exposed to and the type of structural application. For concrete used for pavement and bridge construction applications, the average initial ambient temperature is used to define the testing ages. The average initial ambient temperature is defined as the average ambient temperature for the first 12 hours after the cylinders are made. Tests cylinders at the ages shown in the following table:</p> <table border="1"> <thead> <tr> <th rowspan="2">Average Initial Ambient Temperature</th> <th colspan="5">Target Real-Time Testing Age</th> </tr> <tr> <th>Set 1 (Hr)</th> <th>Set 2 (Days)</th> <th>Set 3 (Days)</th> <th>Set 4 (Days)</th> <th>Set 5 (Days)</th> </tr> </thead> <tbody> <tr> <td>40 to 50° F</td> <td>36</td> <td>3</td> <td>6</td> <td>10</td> <td>28</td> </tr> <tr> <td>50 to 60° F</td> <td>30</td> <td>2½</td> <td>6</td> <td>10</td> <td>28</td> </tr> <tr> <td>60 to 80° F</td> <td>24</td> <td>2</td> <td>4</td> <td>7</td> <td>28</td> </tr> <tr> <td>80 to 90° F</td> <td>20</td> <td>1¾</td> <td>3</td> <td>6</td> <td>28</td> </tr> <tr> <td>More than 90° F</td> <td>18</td> <td>1½</td> <td>3</td> <td>6</td> <td>28</td> </tr> </tbody> </table>	Average Initial Ambient Temperature	Target Real-Time Testing Age					Set 1 (Hr)	Set 2 (Days)	Set 3 (Days)	Set 4 (Days)	Set 5 (Days)	40 to 50° F	36	3	6	10	28	50 to 60° F	30	2½	6	10	28	60 to 80° F	24	2	4	7	28	80 to 90° F	20	1¾	3	6	28	More than 90° F	18	1½	3	6	28
Average Initial Ambient Temperature	Target Real-Time Testing Age																																									
	Set 1 (Hr)	Set 2 (Days)	Set 3 (Days)	Set 4 (Days)	Set 5 (Days)																																					
40 to 50° F	36	3	6	10	28																																					
50 to 60° F	30	2½	6	10	28																																					
60 to 80° F	24	2	4	7	28																																					
80 to 90° F	20	1¾	3	6	28																																					
More than 90° F	18	1½	3	6	28																																					

Table 1: ... continued from previous page

Step	Action
	<p>When the maturity method is used for precast prestressed applications then the testing ages of 6, 12, 24 hours and 3, 7, 28 days shall be used.</p> <p>Perform compression tests at ages in accordance with AASHTO T 22 and by using neoprene pads. Additional cylinders and test ages may be used at the discretion of the Engineer. Test three cylinders at each age and compute the average strength.</p> <p>When an individual cylinder strength is more than ±10 percent outside the average of the other two cylinders, the cylinder's result can be considered defective and it may be discarded. When two of the three cylinders are defective, a new batch must be evaluated unless additional acceptable cylinders are available to be tested at this age.</p>
6	<p>At each test age, record the individual and average values of maturity and strength on a permanent data sheet.</p>
7	<p>Plot the average strengths versus average maturity values. Using a computer spreadsheet program, calculate a best-fit exponential strength-maturity function (defined below) for the data set. Calculate the coefficient of determination (r^2) as defined below. Record the equation of the curve as well as the r^2 value. The r^2 value shall not be less than 0.95, if it is then a new strength-maturity relationship must be developed. Once the best-fit exponential strength-maturity function has been developed, it must be adjusted to obtain the reliability assumed in current design provisions. The adjusted strength-maturity relationship is obtained by multiplying the best-fit S_u by 0.95. The adjusted strength-maturity relationship is the strength-maturity relationship that shall be used to estimate the strength of the concrete.</p> <p>Exponential Strength-Maturity Function: $S(M) = S_u \cdot \exp\left(-\left[\frac{A}{M}\right]^B\right)$</p> <p>where, $S(TTF)$ = compressive strength at maturity of TTF (psi), M = maturity in time-temperature factor units (hr·°C), S_u = ultimate compressive strength (psi), B = slope constant for the strength-maturity relationship, and A = time constant for the strength-maturity relationship (hr·°C).</p> <p>Coefficient of Determination (r^2): $r^2 = 1 - \left(\frac{\sum (S_m - S_{est})^2}{\sum (S_m - S_{m,avg})^2} \right)$</p> <p>where, S_m = measured compressive strength at each test age (psi), $S_{m,avg}$ = average of all measured compressive strengths (psi), and S_{est} = estimated compressive strength at each test age (psi).</p>
8	<p>The following data shall be submitted for approval: contractor name; concrete testing laboratory name; concrete batch date, time, and size; raw material type and source; mixture proportions; fresh concrete properties; individual and average strength and maturity results; a graph of the strength-maturity relationship with average data points; and S_u, B, A, and r^2 values. The data shall be circulated and signed by the Contractor or his representative and reviewed by the Concrete Engineer or ALDOT Materials and Test Section. Copies are to be provided to the Engineer, the Materials Laboratory, and the Contractor.</p>
9	<p>The approved strength-maturity relationship is only valid for the submitted mixture proportions and raw materials used to produce the concrete. A new strength-maturity relationship must be developed if changes in the sources of the material, proportions, and mixing equipment occur. If the water-to-cementitious materials ratio is changed by more than 0.02 then a new strength-maturity relationship must be developed.</p>

Table 2: Procedure to Estimate the In-Place Strength

Step	Action
1	Use the predetermined adjusted strength-maturity relationship to determine the Required Maturity to achieve the Required Design Strength.
2	<p>Prior to concrete placement, install a minimum of two maturity sensors at locations in the structure that are critical in terms of structural considerations or geometry as directed by the Engineer. Critical maturity sensor locations may include thinner sections of a slab, members exposed to the most severe weather, the last concrete poured, or concrete adjacent to prestressing strands. Maturity sensors may not be in direct contact with reinforcing steel or formwork. Sensors may be attached to insulated wire that is tied between reinforcing bars.</p> <p>In pavement and bridge construction applications, a minimum of 2 maturity sensors will be placed 10 ft. from the end of the day's production or in the last patch of the day. Maturity sensors shall be placed 2 inches from bottom surface or form, or at mid-depth of the section for sections less than 4 inches. The sensors shall also be placed approximately 1½ feet from the longitudinal edge of the structure.</p> <p>For bridge elements, such as columns, footings, column caps, and diaphragms, 2 sensors shall be installed in the upper corner, 2 to 4 inches from any surface of the exposed surface.</p> <p>For precast prestressed applications, 2 sensors shall be installed where lower temperatures are expected in the member. This location is recommended to be near the outer surface of the bottom flange at the girder ends. The final location of the sensors will be determined by the Engineer.</p>
3	As soon as practical after concrete placement, connect and activate the maturity recording device(s). Do not stop recording until the required maturity values are achieved. Data collection must be uninterrupted.
4	Periodically record maturity data on a permanent data sheet. The permanent data sheet shall show the Required Design Strength and the Required Maturity for the specified operation.
5	When the maturity is equal to or greater than the Required Maturity for that concrete application, record the data, time, and maturity value. Do not remove the maturity recording device from the structure.
6	Verification tests are required to ensure that the strength estimated by the maturity method has been reached and that the Strength-Maturity Relationships is representative for the concrete as delivered to site. Verify the strength estimated by the maturity method by testing the verification cylinders as outlined in Table 3.
7	<p>Compute the percent error (defined below) between the estimated and measured verification cylinder strength. A positive error indicates that the strength is overestimated by the maturity method and this type of error is unconservative. A negative error indicates that the strength is underestimated by the maturity method and this type of error is conservative.</p> $Error = \left(\frac{S_{est} - S_m}{S_m} \right) \times 100 \quad (\%)$ <p>where, S_m = average measured compressive strength at each test age (psi), and S_{est} = average estimated compressive strength at each test age (psi).</p>
8	If the percent error between the estimated and measured verification cylinder strength is +5.0% or less, then the in-place concrete is deemed to have sufficient strength. Once the concrete is deemed to have sufficient strength the maturity recording device may be removed from the structure.

Table 2: ... continued from previous page

Step	Action
9	If the percent error between the estimated and measured verification cylinder strength is more than +5.0%, then the in-place concrete is deemed to have insufficient strength. The remaining verification cylinders need to be tested at a later age to ensure that the in-place concrete has sufficient strength.

Table 3: Procedure to Verify the Strength Estimated by the Maturity Method

Step	Action
1	Make a minimum of seven (7) verification cylinders for every location in the structure where maturity probes are installed.
2	Embed two maturity sensors in one cylinder. Maturity probes shall be placed 1½ inches from any surface. Start recording maturity as soon so as the concrete is placed and data collection must be uninterrupted. Do not use the cylinder with the maturity sensor for strength testing.
4	The cylinders are to be cured the same way the cylinders were cured to develop the strength-maturity relationship.
5	<p>Perform compression tests, when the cylinder achieves the Required Maturity, or when the Required Maturity of the member is achieved in the field. When the cylinders have been cured at temperatures lower than the structure, the structure will reach the Required Maturity first, and the cylinders will thus be tested at a maturity lower than the Required Maturity. When the cylinders have been cured at temperatures higher than the structure, the cylinders will reach the Required Maturity first.</p> <p>Test three (3) cylinders in accordance with AASHTO T-21, and compute the average strength of the cylinders. When an individual cylinder strength is more than ±10 percent outside the average of the other two cylinders, the cylinder's result can be considered defective and it may be discarded.</p>
6	<p>Record the individual and average values of maturity and measured cylinder strengths on a permanent data sheet. Use the predetermined adjusted strength-maturity relationship and determine the estimated strength at the cylinder's measured maturity.</p> <p>Compute the percent error (defined below) between the estimated and measured verification cylinder strength.</p>
7	If the percent error between the estimated and measured verification cylinder strength is +5.0% or less, then the strength-maturity relationship shall be considered representative of the concrete delivered to site.
8	<p>If the percent error between the estimated and measured verification cylinder strength is more than +10%, then a new strength-maturity relationship shall be developed. Additionally, if three (3) consecutive percent errors between the estimated and measured verification cylinder strength ranges between +5% to +10%, a new strength-maturity relationship shall be developed.</p> <p>When verification test results indicate the strength-maturity relationship is invalid, maturity testing shall be discontinued until a new strength-maturity relationship has been approved for use in accordance with this specification. Until that time, compressive strength testing in accordance with conventional ALDOT standards shall be implemented for the project. There will be no additional compensation for this work.</p>

APPENDIX A RECORD LOG TO DEVELOP THE STRENGTH-MATURITY RELATIONSHIP

Project: _____
 Conc. Class: _____
 Contractor: _____
 Date / Time Batch⁽¹⁾: _____
 Producer: _____

Sensor/Meter ID No.	
Maturity Sensor Location	
Air Temp. at Placement (°F)	
Conc. Temp. at Placement (°F)	
Slump (inches)	
Air Content (%)	
Batch Size (%)	

Note (1): Attach copy of batch ticket.

STRENGTH-MATURITY RELATIONSHIP RESULTS:

Exponential Strength-Maturity Relationship: $S(M) = S_u \cdot \exp\left(-\left[\frac{A}{M}\right]^B\right)$

Ultimate Compressive Strength (S_u): _____ psi
 0.95 x S_u : _____ psi
 Slope constant (B): _____
 Time Constant (A): _____ hr·°C
 Coefficient of determination (r^2) ⁽²⁾: _____

Note (2): The r^2 value may not be less than 0.95.

STRENGTH AND MATURITY LOG

Technician: _____

Location: _____

Set	DATE & TIME	ACTUAL AGE (DAYS)	TEST NUMBER	TESTED STRENGTH (PSI)	ERROR ⁽³⁾ (%)	MATURITY (Hr.°C)
1			1			
			2			
			3			-
			Average		-	
2			1			
			2			
			3			-
			Average		-	
3			1			
			2			
			3			-
			Average		-	
4			1			
			2			
			3			-
			Average		-	
5			1			
			2			
			3			-
			Average		-	
6			1			
			2			
			3			-
			Average		-	

Note (3): The percent error may not exceed ±10%.

APPENDIX B RECORD LOG FOR FIELD MATURITY DATA

Project: _____
 Conc. Class: _____
 Contractor: _____
 Producer: _____
 Date / Time Batch⁽¹⁾: _____
 Required Strength: _____ psi
 Required Maturity: _____ Hr. °C

Sensor/Meter ID No.						
Maturity Sensor Location						
Air Temp. at Placement (°F)						
Conc. Temp. at Placement (°F)						
Slump (inches)						
Air Content (%)						
Reading ⁽²⁾	Inspector	DATE & TIME	Air Temp. (°C)	Sensor	Conc. Temp. (°F)	Maturity (Hr.°C)
1				1		
				2		
				Average		
2				1		
				2		
				Average		
3				1		
				2		
				Average		
4				1		
				2		
				Average		

Note (1): Attach copy of batch ticket.
 Note (2): When each reading is taken, verify that the specified curing procedures are being followed.

APPENDIX C RECORD LOG FOR VERIFICATION TESTING

Project: _____
 Conc. Class: _____
 Date / Time Batch: _____
 Required Strength: _____ psi
 Required Maturity: _____ Hr·°C
 Sensor/Meter ID No.: _____
 Testing Technician: _____

STRENGTH RESULTS:

Date & time	Actual Age (days)	Test Number	Tested strength (psi)	Error (%)
		1		
		2		
		3		
		Average		-

MATURITY RESULTS:

Date & time	Actual age (days)	Sensor	Maturity (hr·°c)
		1	
		2	
		Average	

STRENGTH ESTIMATION RESULTS:

Average Maturity (Hr·°C)	Estimated Strength (psi)	Average Tested Strength (psi)	Error (%)

APPENDIX D - EXAMPLE CALCULATIONS RECORD LOG TO DEVELOP THE STRENGTH-MATURITY RELATIONSHIP

Project: U.S. 29 Bridge Deck over I 85

Conc. Class: Type A-1c

Contractor: To be completed.

Date / Time Batch⁽¹⁾: 06/13/2003 8:20am

Producer: To be completed.

Sensor/Meter ID No.	13383 A
Maturity Sensor Location	Mid-depth of 6 x 12 Cylinder
Air Temp. at Placement (°F)	70
Conc. Temp. at Placement (°F)	81
Slump (inches)	2.5
Air Content (%)	3.5
Batch Size (%)	4.0

Note (1): Attach copy of batch ticket.

STRENGTH-MATURITY RELATIONSHIP RESULTS:

Exponential Strength-Maturity Relationship: $S(M) = S_u \cdot \exp\left(-\left[\frac{A}{M}\right]^B\right)$

Ultimate Compressive Strength (S_u): 6,115 psi

0.95 x S_u : 5,810 psi

Slope constant (B): 0.552

Time Constant (A): 711.2 hr.°C

Coefficient of determination (r^2)⁽²⁾: 0.998

Note (2): The r^2 value may not be less than 0.95.

STRENGTH AND MATURITY LOG

Technician: To be completed.

Location: To be completed.

Set	DATE & TIME	ACTUAL AGE (DAYS)	TEST NUMBER	TESTED STRENGTH (PSI)	ERROR ⁽³⁾ (%)	MATURITY (Hr·°C)
1	06/13/2003 @ 8:21am	1.0	1	2,260	-0.2	720
			2	2,210	-3.5	730
			3	2,320	3.8	-
			Average	2,260	-	725
2	06/14/2003 @ 8:15am	2.0	1	3,100	-4.6	1,481
			2	3,200	0.0	1,509
			3	3,300	4.8	-
			Average	3,200	-	1,495
3	06/16/2003 @ 10:00am	4.1	1	3,840	2.7	2,852
			2	3,780	0.3	2,868
			3	3,700	-2.9	-
			Average	3,770	-	2,860
4	06/19/2003 @ 8:50am	7.0	1	4,380	1.2	4,760
			2	4,060	-9.6	4,768
			3	4,600	9.0	-
			Average	4,350	-	4,764
5	07/10/2003 @ 1:37pm	28.2	1	5,310	3.8	18,500
			2	5,000	-5.1	18,600
			3	5,230	1.5	-
			Average	5,180	-	18,550
6	NA	NA	1			
			2			
			3			
			Average		-	

Note (3): The percent error may not exceed ±10%.

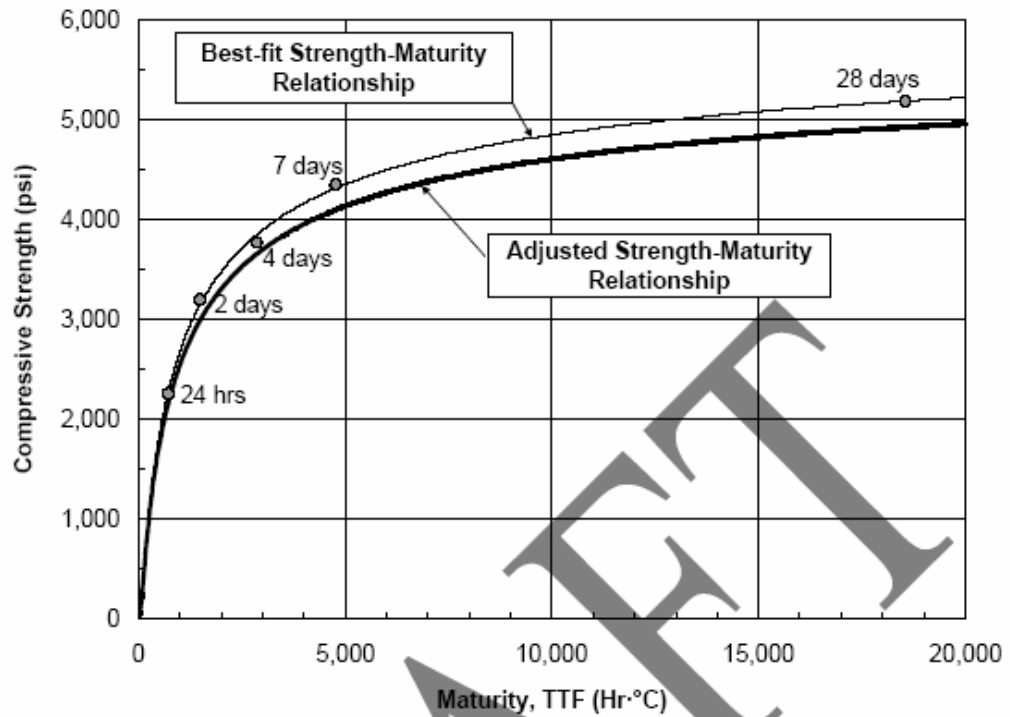

Figure A: Strength-Maturity Relationship for the example problem

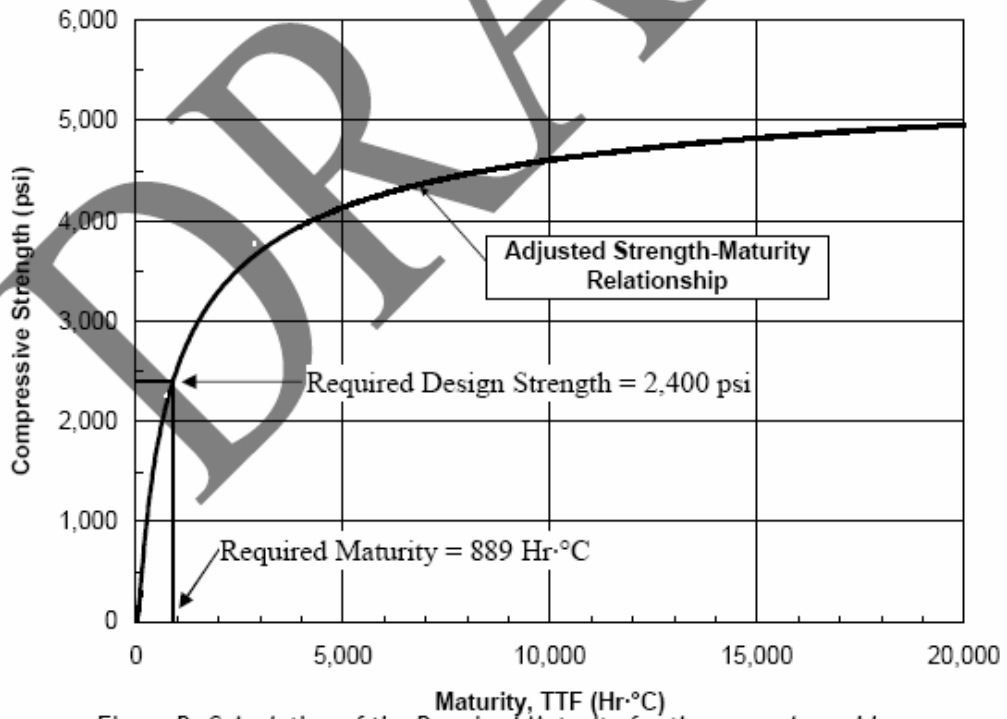

Figure B: Calculation of the Required Maturity for the example problem

RECORD LOG FOR FIELD MATURITY DATA

Project: U.S. 29 Bridge Deck over I 85

Conc. Class: Type A-1c

Contractor: To be completed.

Producer: To be completed.

Date / Time Batch⁽¹⁾: 07/14/2003 10:15am

Required Strength: 2,400 psi

Required Maturity: 889 Hr.°C

Sensor/Meter ID No.		13445 G				
Maturity Sensor Location		Station +50.0, Mid-depth, Last pour				
Air Temp. at Placement (°F)		70				
Conc. Temp. at Placement (°F)		81				
Slump (inches)		2.5				
Air Content (%)		3.5				
Reading ⁽²⁾	Inspector	DATE & TIME	Air Temp. (°C)	Sensor	Conc. Temp. (°F)	Maturity (Hr.°C)
1	<i>Initials</i>	07/14/2003 @ 5:15pm	87	1	93	415
				2	95	431
				Average	94	423
2	<i>Initials</i>	07/15/2003 @ 6:10am	63	1	86	786
				2	88	796
				Average	87	791
3	<i>Initials</i>	07/15/2003 @ 9:00am	74	1	91	898
				2	93	914
				Average	92	906
4				1		
				2		
				Average		

Note (1): Attach copy of batch ticket.

Note (2): When each reading is taken, verify that the specified curing procedures are being followed.

RECORD LOG FOR VERIFICATION TESTING

Project: U.S. 29 Bridge Deck over I 85

Conc. Class: Type A-1c

Date / Time Batch: 07/14/2003 10:15am

Required Strength: 2,400 psi

Required Maturity: 889 Hr·°C

Sensor/Meter ID No.: 13945 K

Testing Technician: To be completed.

STRENGTH RESULTS:

Date & time	Actual Age (days)	Test Number	Tested strength (psi)	Error (%)
07/15/2003 @ 9:45am	0.95	1	2,250	-8.0
		2	2,500	7.8
		3	2,390	0.6
		Average	2,380	-

MATURITY RESULTS:

Date & time	Actual age (days)	Sensor	Maturity (hr·°C)
07/15/2003 @ 9:30am	0.95	1	792
		2	798
		Average	795

STRENGTH ESTIMATION RESULTS:

Average Maturity (Hr·°C)	Estimated Strength (psi)	Average Tested Strength (psi)	Error (%)
795	2,270	2,380	-4.6

Conclusions:

1. The in-place concrete has sufficient strength.
2. The strength-maturity relationship is representative of the concrete delivered to site.

APPENDIX E

TEXAS DOT MATURITY SPECIFICATION TEX-426-A

The Texas Department of Transportation maturity specification Tex-426-A (2004) is presented in the following pages. The specification can be found on the internet at the Texas Department of Transportation website.



Chapter 4 Chapter 27 - Tex-426-A, Estimating Concrete Strength by the Maturity Method

Section 1. Overview

Effective date: August 2002.

This test method provides a procedure for estimating concrete strength by means of the maturity method. The maturity method is based on strength gain as a function of temperature and time.

The maturity method consists of three steps:

- ◆ develop strength-maturity relationship
- ◆ estimate in-place strength
- ◆ verify strength-maturity relationship.

The Nurse-Saul "temperature-time factor (TTF) " maturity index shall be used in this test method, with a datum temperature of -10 °C (14 °F).

Units of Measurement

The values given in parentheses (if provided) are not standard and may not be exact mathematical conversions. Use each system of units separately.

Combining values from the two systems may result in nonconformance with the standard.

Section 2. Apparatus

The following apparatus is required:

- ◆ If the maturity meter has input capability for datum temperature, verify that the proper value of the datum temperature has been selected prior to each use.
- ◆ Commercial battery-powered maturity meters that automatically compute and display the maturity index in terms of a temperature-time factor, or both a temperature-time factor and equivalent age, are acceptable.
 - Batteries in maturity meters are to be adequately charged prior to use. The same brand and type of maturity meters shall be used in the field as those used to develop and verify the strength-maturity relationship.
 - A minimum of one maturity meter shall be provided for each thermocouple location. The Engineer may allow the use of a multi-channel meter when several thermocouples are in close proximity.
 - Meters shall be protected from excessive moisture and theft, and the LCD display shall be protected from direct sunlight.

NOTE 1: Commercial maturity meters use specific values of datum temperature or activation energy in evaluating the maturity; thus the displayed maturity index may not be the same for different brands and types of maturity meters.

- ◆ Thermocouple wire grade greater than or equal to 20 awg.

Section 3. Procedures

Calibration

Verify calibration prior to use on a project and, as a minimum, on an annual basis by placing a thermocouple in a controlled-temperature water bath and recording whether the indicated result agrees with the known temperature of the water bath. At least 3 different temperatures, for example, 5 °C, 25 °C, and 45 °C (41 °F, 77 °F, 113 °F), are recommended. The temperature recording device shall be accurate to within ± 1 °C (2 °F).

Developing Strength-Maturity Relationship

The following table outlines the procedure for developing strength-maturity relationship.

Developing Strength-Maturity Relationship

Step	Action
1	<p>For every concrete design that will be evaluated by the maturity method, prepare a minimum of 20 cylinders or beams according to Test Method "Tex-447-A, Making and Curing Concrete Test Specimens."</p> <p>Additional specimens should be cast to avoid having to repeat the procedure.</p> <p>The mixture proportions and constituents of the concrete shall be the same as those of the job concrete whose strength will be estimated using this practice.</p> <p>The minimum size of each batch shall be approximately 3 m³ (4 yd³).</p>
2	<p>Fresh concrete testing for each batch shall include concrete placement temperature, slump, and air content according to test methods "Tex-415-A, Slump of Portland Cement Concrete" and Air Content of Freshly Mixed Concrete by the Volumetric Method " or "Tex-416-A, Air Content of Freshly Mixed Concrete by the Pressure Method."</p>
3	<p>Embed thermocouples in at least two specimens using two maturity meters.</p> <p>Place thermocouples 50 to 100 mm (2 to 4 in.) from any surface.</p> <p>Connect the thermocouples to maturity meters. Do not disconnect meters. Data collection must be uninterrupted.</p>
4	<p>Moist-cure the specimens in a water bath or in a moist room according to Test Method "Tex-447-A, Making and Curing Concrete Test Specimens."</p>
5	<p>Perform compression or flexural tests at ages of 1, 3, 5, 7, 14, and 28 days according to Test Method(s) "Tex-418-A, Compressive Strength of Cylindrical Concrete Specimens" or "Tex-448-A, Flexural Strength of Concrete Using Simple Beam Third-Point Loading" as appropriate.</p> <p>Additional specimens and test ages may be evaluated at the discretion of the Engineer.</p> <p>Test three specimens at each age and compute the average strength.</p> <p>NOTE: The specimens with thermocouples are to be tested last.</p> <p>If a specimen is obviously defective (for example, out of round, not square, damaged due to handling), discard the specimen.</p> <p>If an individual cylinder strength is greater than 10 percent (15 percent for beams) outside the average of three specimens, the specimen can be considered defective and be discarded.</p> <p>When two of the three specimens are defective, a new batch must be evaluated unless additional acceptable specimens are available.</p>
6	<p>At each test age, record the individual and average values of maturity and strength for each batch on a permanent data sheet. (See 'Record Log to Develop Strength-Maturity Relationship(1)' for sample record log.)</p>
7	<p>Plot the average strengths as a function of the average maturity values, with data points shown.</p> <p>Using a computer spreadsheet program such as Microsoft Excel, calculate a logarithmic best-fit curve through the data.</p> <p>Record the equation of the curve as well as the R² value. The resulting curve is the strength-maturity relationship to be used for estimating the strength of the concrete mixture placed in the field.</p> <p>NOTE: When developing the strength-maturity relationship, the spreadsheet software allows the Engineer to develop the corresponding maturity equation that defines the strength-maturity relationship and an R² value to fit the strength-maturity relationship. The R² value indicates the reliability of the strength-maturity relationship. Expected results should produce an R² value of no less than 0.90. When the reliability is less than 0.90, the Engineer should carefully examine the data for "outliers, " faulty beam breaks, or faulty maturity readings. The Engineer</p>

	should use judgment to determine if certain points should be discarded, or retested, or whether the entire strength-maturity relationship should be regenerated.
8	The plot, with data points, of the strength-maturity relationship for each concrete mixture shall be circulated and signed by the Contractor or his representative and reviewed by the District Materials Engineer or the Construction Division, Materials & Pavements Section. Provide copies to the Engineer, the District Materials Laboratory, and the Contractor.

Estimating In-Place Strength

The following table outlines the steps for estimating in-place strength.

Estimating In-Place Strength	
Step	Action
1	<p>A TxDOT inspector should be present at the concrete plant when placing concrete that will be evaluated by the maturity method.</p> <p>For Structural and Pavement Concrete, the inspector shall be at the plant on a daily basis, and shall verify batching operations using a checklist.</p> <p>For Miscellaneous Concrete, the inspector shall be at the plant a minimum of once per week on a random basis, and shall verify batching operations using a checklist.</p> <p>NOTE: Any alteration in mix proportions or source or type of any material, in excess of those tolerable by batching variability, requires the development of a new strength-maturity relationship prior to its use. This includes a change in type, source, or proportion of cement, fly ash, coarse aggregate, fine aggregate, or admixtures. A change in water-to-cementitious material ratio greater than 0.05 requires the development of a new strength-maturity relationship. (See 'Inspector's Batch Plant Checklist' for example checklist.)</p>
2	<p>Prior to or at the time of concrete placement, install thermocouples at the frequency specified in the pertinent item of work.</p> <p>Install a minimum of two thermocouples, using two maturity meters, at locations in the structure that are critical in terms of structural considerations or exposure conditions as directed by the Engineer.</p> <p>Place thermocouples 50 to 100 mm (2 to 4 in.) from any formed surface or at mid-depth of the section for sections less than 50 mm (4 in.).</p> <p>NOTE: Thermocouples may be tied to reinforcing steel, but should not be in direct contact with the reinforcing steel or formwork.</p>
3	<p>When verification tests are required or when maturity will be used to estimate strength for removal of structurally critical formwork or falsework, or for steel stressing or other safety-related operations, specimen strength tests shall be done according to 'Verifying Strength-Maturity Relationship.'</p>
4	<p>As soon as practical after concrete placement, connect and activate the maturity meter(s).</p> <p>NOTE: Do not disconnect meters until the required maturity values are achieved. Data collection must be uninterrupted.</p>
5	<p>Record maturity data on a permanent data sheet. The permanent data sheet shall show the Required Strength and the Required TTF for the specified Operation. (See 'Record Log for Field Maturity Data (1) with Sample Data' sample record log.)</p>
6	<p>When the maturity is at a value that is equal to or greater than the required strength for that concrete mixture, as determined by the strength-maturity relationship, record the</p>

	maturity value and when appropriate as per Step 3, verify the specimen strength according to 'Verifying Strength-Maturity Relationships. ' Then remove the meter and clip the thermocouple wires at the concrete surface.
--	------------------------------------------------------------------------------------------------------------------------------------------------------------------------------------------------------------------------------

Verifying Strength-Maturity Relationship

NOTE: When maturity is used to estimate strength for removal of structurally-critical formwork or falsework, or for steel stressing or other safety-critical operations, the specimen strength tests may be included as Verification Tests.

Verifying Strength-Maturity Relationship	
Step	Action
1	Make a minimum of either three cylinders or three beams according to Test Method(s) " Tex-418-A , Compressive Strength of Cylindrical Concrete Specimens " or " Tex-448-A , Flexural Strength of Using Simple Beam Third-Beam Loading " respectively, at the frequency specified in the pertinent item of work.
2	Fresh concrete testing shall include concrete placement temperature, slump, and air content according to test methods " Tex-415-A , Slump of Portland Cement Concrete " and " Tex-414-A , Air Content of Freshly Mixed Concrete by the Volumetric Method " or " Tex-416-A , Air Content of Freshly Mixed Concrete by the Pressure Method. "
3	Embed thermocouples in two specimens. Place thermocouples 50 to 100 mm (2 to 4 in.) from any surface. Connect the thermocouples to maturity meters. Do not disconnect meters. Data collection must be uninterrupted.
4	Moist-cure the specimens in a water bath or in a moist room in accordance with Test Method " Tex-447-A , Making and Curing Concrete Test Specimens. "
5	Perform compression or flexural strength tests, as appropriate, when the specimen achieves the TTF (within 10%) corresponding to the design strength, or when the required TTF of the member is achieved in the field if estimating strength for removal of structurally critical formwork or falsework or for steel stressing or other safety-related operations. Test the three specimens according to Test Method(s) " Tex-418-A , Compressive Strength of Cylindrical Concrete Specimens " or " Tex-448-A , Flexural Strength of Concrete Using Simple Beam Third-Point Loading " and compute the average strength of the specimens. If a specimen is obviously defective (for example, out of round, not square, damaged due to handling), discard the specimen. If an individual cylinder strength is greater than 10 percent (15 percent for beams) outside the average of three specimens, the specimen can be considered defective and be discarded. When two of the three specimens are defective, a new batch must be evaluated unless additional acceptable specimens are available.
6	Compare the average strength determined from the specimen breaks to the strength predicted by the strength-maturity relationship. The average strength of the specimens shall be within the verification tolerance specified for the item of work. When three (3) consecutive verification test results fall between 5% and 10% above or below the predicted strength based on the S-M Relationship, the condition does not warrant a redo of the S-M Relationship; the condition, however, requires a mathematical adjustment to the S-M Relationship. Adjust the curve using the adjustment feature of the Excel spread sheet program.

	When a single verification test exceeds the 10%, a new S-M Relationship curve must be developed according to specification requirements.
--	------------------------------------------------------------------------------------------------------------------------------------------

Section 4. Forms

The following forms may be used:

- ◆ [Record Log to Develop Strength-Maturity Relationship](#)
- ◆ [Record Log for Field Maturity Data with Sample Data](#)
- ◆ [Record Log to Verify Strength-Maturity Relationship](#)
- ◆ [Inspector 's Batch Plant Checklist.](#)



Record Log to Develop Strength-Maturity Relationship⁽¹⁾

Control: _____
 Project: _____
 Highway: _____
 Structure: _____
 Engineer: _____
 Producer: _____

Lab Technician: _____
 Member: _____
 Item No.: _____
 Conc. Class/Mix No.: _____
 Date/Time Batch: _____
 Required TTF/Action: _____

Meter No.:		Specimen 1:				Specimen 2:						
Batch No.:												
Air Temp. at Placement:						°F			°C			
Slump:						inches			mm			
Air Content:						%						
Date	Time (hr:min)	Tank Temp (°C)	Instrumented Specimens for Monitoring Maturity						Strength Test Results (psi)			
			Specimen 1		Specimen 2		Average Value		1	2	3	Average
			Conc. Temp (°C)	TTF (°C·hr)	Conc. Temp (°C)	TTF (°C·hr)	Conc. Temp (°C)	TTF (°C·hr)				
Comments:												

Note (1): Attach copy of batch ticket.

641

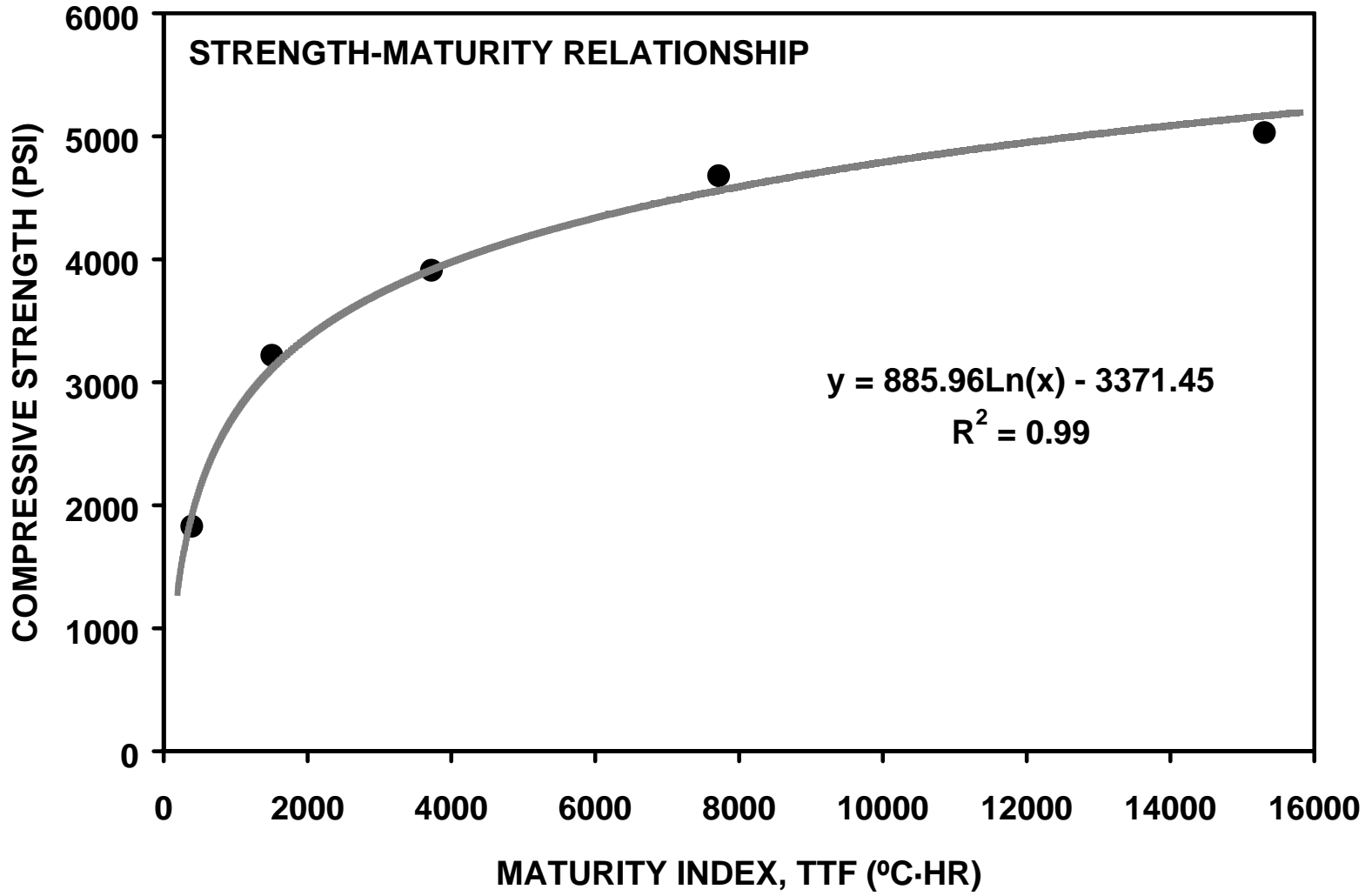

Record Log for Field Maturity Data⁽¹⁾ with Sample Data

643

Structure																
Member																
Meter No.																
Meter Location																
Spec. Item No.																
Conc. Class & Mix No.																
Date/Time Batch																
Air. Temp. Placed		°F		°C			°F		°C			°F		°C		
Conc. Temp. Placed		°F		°C			°F		°C			°F		°C		
Slump		inches		mm			inches		mm			inches		mm		
Air Content		%					%					%				
Required Strength		psi					psi					psi				
Required TTF		°C-hr					°C-hr					°C-hr				
Operation																
Inspector	Reading No. ⁽²⁾	Date	Time (hh:min)	Air Temp. (°C)	Conc. Temp. (°C)	TTF (°C-hr)	Date	Time (hh:min)	Air Temp. (°C)	Conc. Temp. (°C)	TTF (°C-hr)	Date	Time (hh:min)	Air Temp. (°C)	Conc. Temp. (°C)	TTF (°C-hr)
Comments																

Note (1): Attach copy of batch ticket(s)
 Note (2): When each reading is taken, verify that the specified curing procedures are being followed.

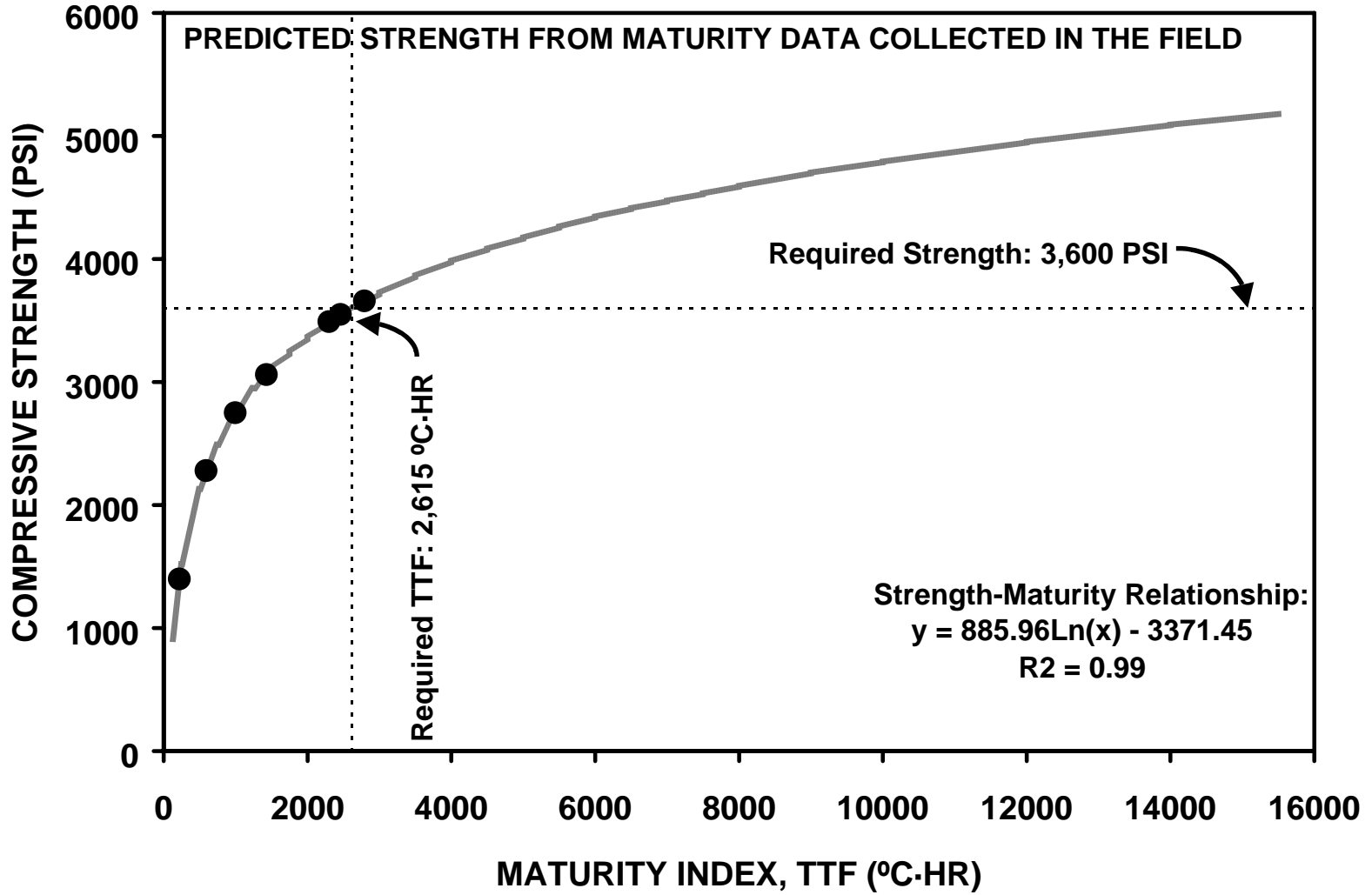

Record Log to Verify Strength-Maturity Relationship⁽¹⁾

Control: _____
 Project: _____
 Highway: _____
 Structure: _____
 Engineer: _____
 Contractor: _____
 Producer: _____

Technician: _____
 Member: _____
 Item No.: _____
 Conc. Class/Mix No.: _____
 Date/Time Batch: _____
 Location of Sampling: _____

Meter No.	Specimen 1:	Specimen 2:											
Batch No. (internal laboratory control number):													
Air Temp. at Placement	°F	°C											
Concrete Temp. at Placement	°F	°C											
Slump	inches	mm											
Air Content	%	%											
Required Strength of the Member:	psi												
Required TTF of the Member:	°C-hr												
Operation:													
Date	Time⁽²⁾ (hr:min)	Verification Test											
		Instrumented Specimens for Monitoring Maturity							Strength Test Results (psi)				Percent Difference⁽³⁾
		Specimen 1		Specimen 2		Average Value							
		Conc. Temp (°C)	TTF (°C·hr)	Conc. Temp (°C)	TTF (°C·hr)	Conc. Temp (°C)	TTF (°C·hr)	Predicted Strength (psi)	1	2	3	Avg.	
Comments:													

Note (1): Attach copy of batch ticket

Note (2): Perform compression or flexural strength tests, as appropriate, when (a) the specimen achieves the TTF corresponding to the design strength, or (b) the required TTF of the member is achieved in the field if verifying for structurally-critical formwork or falsework or steel stressing or other safety-related operations.

Note (3): % Difference = [(Average Strength – Predicted Strength)/P length] x 100

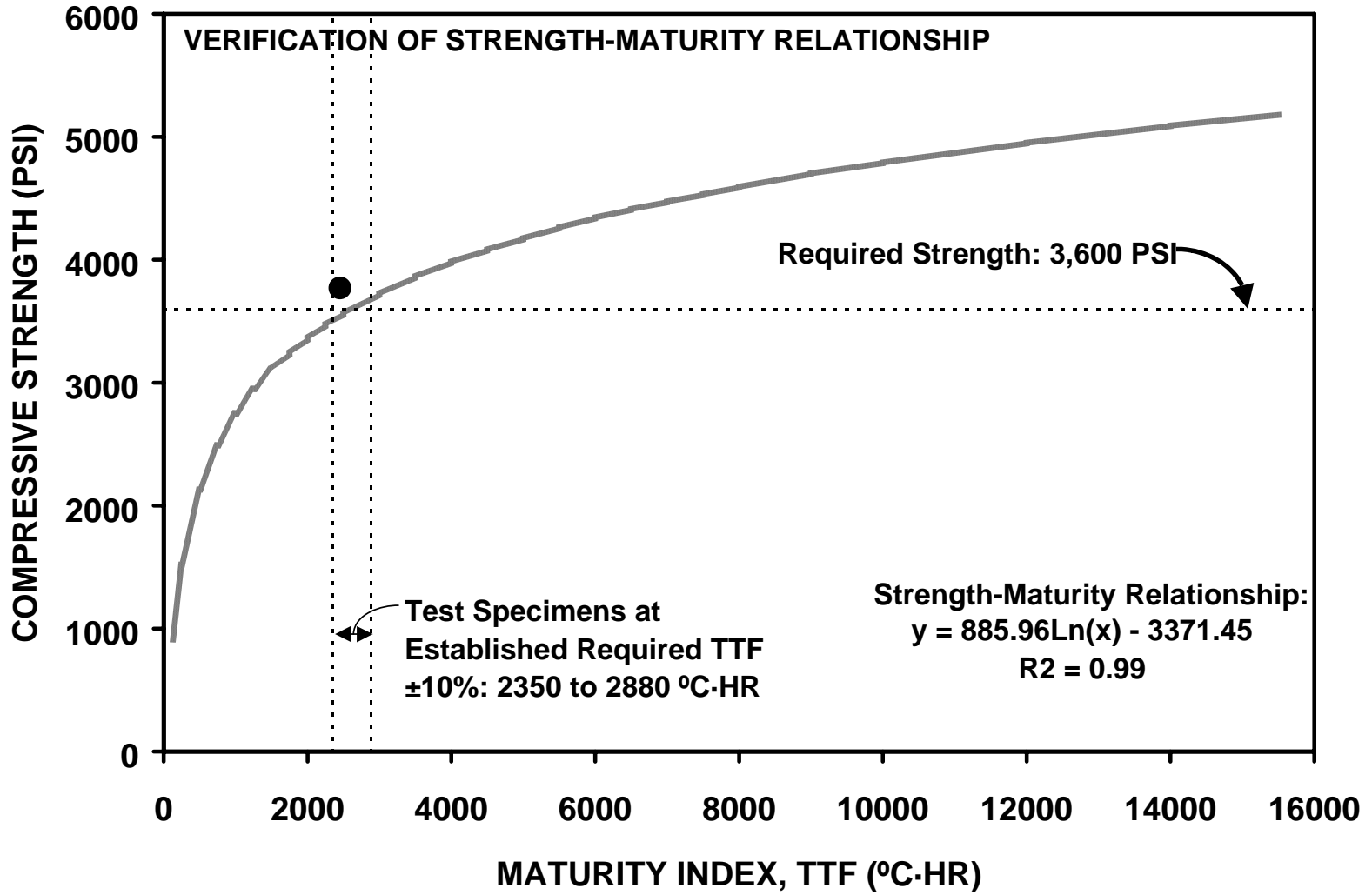

Inspector's Batch Plant Checklist

This checklist is to be completed daily when producing Structural and Pavement Concrete and completed on a weekly basis when producing Miscellaneous Concrete.

Control: _____	Structure: _____
Project: _____	Producer: _____
County: _____	Conc. Class: _____
Highway: _____	Mix No.: _____

	Yes	No
Mix Design:		
Is the correct approved mix design being used?	<input type="checkbox"/>	<input type="checkbox"/>
Comments:		
Are the brands/types of cement, fly ash, admixtures, etc. the same as the batch design?	<input type="checkbox"/>	<input type="checkbox"/>
Comments:		
Aggregates:		
Are coarse and fine aggregates from the same source as used in the batch design?	<input type="checkbox"/>	<input type="checkbox"/>
Comments:		
Are the correct aggregates being loaded into the feed hoppers?	<input type="checkbox"/>	<input type="checkbox"/>
Comments:		
Are the aggregates representative, by visual examination, of those tested? (If no, additional sampling and testing is required prior to use.)	<input type="checkbox"/>	<input type="checkbox"/>
Comments:		
Has a correction been made to reflect the current free moisture in the aggregate stockpiles?	<input type="checkbox"/>	<input type="checkbox"/>
Comments:		
Batch Tickets:		
Do the batch printouts / tickets, when required, accurately reflect the batched concrete?	<input type="checkbox"/>	<input type="checkbox"/>
Comments:		

Inspector's Name

Inspector's Signature

Date

Time (hr:min)

APPENDIX F

IOWA DOT MATURITY SPECIFICATION IM 383

The Iowa Department of Transportation maturity specification IM 383 (2004) is presented in the following pages. The specification can be found on the internet at the Iowa Department of Transportation website.



**METHOD OF TESTING THE STRENGTH OF
PORTLAND CEMENT CONCRETE
USING THE MATURITY METHOD**

GENERAL

This IM outlines the procedure for using the maturity concept as a nondestructive method to determine concrete strength.

This is a two-step procedure. First, a relationship must be established between the maturity values and the concrete strength as measured by destructive methods (that is, through testing of beams or cylinders). The development of the maturity-strength curve shall be done in the field at the beginning of construction using project materials and the project proportioning and mixing equipment. The second step is the instrumentation of the concrete to be measured. Temperature probes are installed in the concrete and the temperature is measured. From those measurements, along with the age at which the measurements were taken, maturity values are determined. A maturity meter or temperature-measuring device and a computer or calculator may also be used to determine the maturity values.

The contractor and the agency shall jointly develop a plan for performing the maturity testing. The plan shall include:

1. The contractor shall be responsible for the development of the maturity curve. The curve development shall be monitored by the contracting agency.
2. The temperature monitoring process of the constructed pavement or structure shall be the responsibility of the contractor and shall be monitored by the contracting agency. Determining that sufficient strength has been achieved shall remain the responsibility of the engineer. The contractor shall provide documentation of maturity testing before a pavement section may be opened to traffic, a structure may be loaded, or the forms may be removed.

For concrete furnished from a construction or stationary mixer, which is in place prior to construction of the specified project, a maturity curve may be established ahead of actual construction of the specified project. The test specimens shall be cast with concrete made from the same plant and using the same materials source as will be used in the specified project. The agency shall be informed and have an opportunity to observe the development of the maturity curve.

THE MATURITY CONCEPT

The hydration of cement and gain in strength of the concrete is dependent on both curing time and temperature. Thus, the strength of the concrete may be expressed as some function of time and temperature. This information can then be used to determine the strength of concrete without conducting physical tests. The time-temperature function commonly used is the maturity concept proposed by Nurse-Saul (ASTM C1074),

$$M (^{\circ}\text{C} \times \text{hours}) = \sum [(T - T_0) \Delta t]$$

Where M is the maturity in $^{\circ}\text{C}$ -hours [M is also termed the time-temperature factor (TTF)], Δt is the time interval in hours (or days), T is the average concrete temperature during the time interval Δt , and T_0 is the datum temperature at which concrete ceases to gain strength with time. The value of $T_0 = 14^{\circ}\text{F}$ (-10°C) is most commonly used. As a result, Equation 1 becomes:

$$M (^{\circ}\text{C} \times \text{hours}) = \sum [(T + 10) \Delta t] \quad \text{Equation 2}$$

ESTABLISHMENT OF MATURITY-STRENGTH RELATIONSHIP

Precaution: When the concrete temperature is below 50°F (10°C), maturity strength development will cause over extended TTF values. Development of strength maturity relationship should be performed on concrete with temperatures above 50°F (10°C).

When air temperatures are expected to fall below 40°F (4°C), place the beams on a piece of foam board or plywood to prevent the cold ground from lowering beam temperatures. Placing insulation over the beams to retain heat may also be warranted.

To establish a maturity-strength relationship for a concrete mix, a maturity meter **or other maturity and continual temperature profiling system** and a hydraulic testing machine are needed. The following procedure shall be used: (**NOTE:** Before using any maturity meter, check to be sure the datum temperature is set to 10°C .) The procedure to check or change the datum temperature is included at the end of this IM

1. Cast a minimum of twelve (12) 6 in. x 8 in. x 20 in. (152 mm x 152 mm x 508 mm) beams, as per IM 328. Test the entrained air content and slump of the concrete being used to cast the beams, as per IM 327. Record these values. The concrete shall meet specifications. Since there is a direct relationship between w/c ratio and strength, the concrete used to develop the maturity-strength relationship shall be at the maximum w/c ratio expected during production. The beams shall be cast from a batch of at least 3m^3 (3 cu. yd.).
2. Embed a thermocouple wire near each end of a test beam (when flexural strength is to be determined) to monitor the temperature. This beam will be the last to be tested. A probe shall be inserted near each beam end to the approximate mid-depth and such that they are approximately 3 in. (75 mm) from each side and each end. Loop the wire around the beam box handles to prevent the wire from being inadvertently pulled out of the beam. The average of the two readings will be used in the development of the maturity-strength curve. When a maturity meter is used, the meter computes the values. Twelve (12) test specimens shall be tested as described in #4 below.
3. Cast, cure, and test the beams at the plant site. Test in accordance to IM 316. This will allow a maturity meter to be protected from the weather and theft. The meter can be stored in a lab trailer or vehicle with the probes run outside to the beam in the sandpit. The beams shall be covered with plastic immediately after casting and prior to form removal. If possible, wet burlap should be placed over the surface of the beams under the plastic. The forms shall be removed the following day. Cure all beams in a pit of wet sand after form removal, until they are tested.

4. Determine maturity values and strength at four different ages. Test three specimens for strength at each age and calculate the average strength at each age. The maturity value shall be calculated from a temperature reading at the time the specimen is tested for strength. The tests shall be spaced such that they are performed at somewhat consistent intervals of time and span a range in strength that includes the opening strength desired. The table below gives suggested maturity values for each test of three standard mixture classes. This is only a guide and may need to be modified, depending on specific mixtures and conditions.

Approximate Maturity Values (TTF)

	Test 1	Test 2	Test 3	Test 4
A Mix	750	1500	2500	3500
B Mix	1500	3500	5500	7500
C Mix	750	1500	2500	3500
M Mix	600	1200	2000	3000

These values assume opening strength for pavements of 3.45 MPa (500 psi) for the A, B and C mixtures, and a five-hour opening for the M mixture with calcium chloride. If the maturity curve is intended for use in determining the time to begin joint sawing, testing must begin at lower maturity values.

For structural concrete, a minimum flexural strength of 3.8 MPa (550 psi) is required before concrete may be subjected to flexural loading. Strength requirements vary for determining when forms for roofs of culverts may be removed (See Article 2403.18). Testing intervals may need to be increased over those for paving.

The first test (Test 1), for Class C mixes, normally would be performed at an age of approximately twelve (12) hours when hot, summer temperatures prevail. During cooler conditions, the first test may be performed at the beginning of the day following the casting of test specimens.

Additional test specimens may be cast at a later time and tested at earlier ages to add data to the strength-maturity relationship as an aid to determining the appropriate time to saw.

5. Plot the measured strength against the corresponding values of maturity at different ages, as determined by the maturity meter or by hand methods. Use a computer program provided by the District Materials Concrete Technician to determine maturity-strength relationship. The TTF number corresponding to the opening strength or the flexural loading strength/form removal strength of the structure shall be used to determine when the pavement has reached opening strength or the structure has reached the required loading strength. An example of the Maturity-Strength Development form, generated by the computer program, is included at the end of this IM This form shall be signed by the contractor/contractor representative and reviewed by the DME. Copies will be provided to the Project Engineer, DME, Central Materials, PCC Engineer, and the contractor.

FIELD PROCEDURE

Equipment

1. 12 - 6 in. x 6 in. x 20 in. (152 mm x 152 mm x 508 mm) beam molds
2. 1 each shovel (square point), rubber hammer or equivalent, and wood float or equivalent
3. 1 each hydraulic testing machine – center point leading flexural
4. 1 each maturity meter or other maturity and temperature profiling system
5. 1 each hand-held thermometer or other continual temperature-monitoring device
6. Type T thermocouple wire
7. Connectors

Placement of the Temperature Probes

Strip the coating from each end of the two wires and twist the ends together before inserting them into the fresh concrete.

For pavements, insert the temperature probe into the concrete until the end is at approximately the pavement mid-depth and 1.8 feet (0.5 m) from the edge of the pavement. The wire ends are the points at which the temperature measurement is taken. Insertion may be accomplished by attaching the wire ends to a wooden dowel and embedding it into the slab. Check to ensure the concrete is consolidated around the dowel. The portion of the dowel that protrudes above the pavement should be cut or broken off after the testing is completed.

Probes may be placed at any point along the pavement slab. A minimum of two probes shall be placed in each day's placement. On days when there is a large difference between daytime high temperatures and nighttime low temperatures, placing additional probes near the beginning of the day's run and at a point near the midday location would provide helpful information. This would be helpful to those sawing the pavement as well as those determining the opening time. It has been found that the concrete does not always gain strength at the same rate. Therefore the concrete placed during the middle of the day can gain strength faster than the concrete placed at the beginning of the day.

For structures, a minimum of two probes shall be attached to the reinforcing steel near the edge at the upper corner of the exposed surface. (See Figure 1 at the end of this IM.) The probe should be wrapped around the rebar and taped with approximately 1 to 2 inches (25 to 50 mm) extending below the rebar to prevent the probe from damage and removal during concrete placement. The rebar should also be taped 2 to 3 inches (50 to 75 mm) on both sides of the probe location to prevent contact with the reinforcing steel. (See Figure 2 at the end of this IM.)

Data Collection

The other probe wire ends, not placed in the concrete, shall be connected to a plug, unless the temperature-measuring device must be connected to the probe directly with bare wires. The plug is then inserted into the maturity meter or thermal meter. Normally a thermal meter can be used to collect field data. Be careful to connect the copper wire to the copper plug prong (+).

When a thermal meter is used, the wire is connected to the meter each time a temperature is taken. Then the wire is disconnected and the value recorded. A Maturity Data Recording Sheet is provided at the end of this IM, which may be used to record the temperature readings and calculate the maturity values.

Do not disconnect the wire from the maturity meter until the test is completed. The data collection must be uninterrupted. Also the maturity meter must be protected from rain or water. If water finds its way inside the meter, permanent damage will result.

Once the wires are placed, an initial temperature of the concrete shall be taken and recorded, when a thermal meter is being used. Temperature readings should be taken in the morning and late afternoon, when one first arrives on the project and before one leaves for the day, as a minimum for standard A, B and C mixtures. For the fast-setting mixtures, readings should be taken every few hours, depending on weather conditions and mixture. If a maturity meter is being used, it should be connected to the probe as soon as possible to begin data collection.

Measuring the Maturity

For pavements, the maturity number can be read directly from the maturity meter or calculated from the temperature readings obtained by the thermal meter or other continual temperature-monitoring device. This number is then used to enter the strength-maturity chart that was established as described above and strength is then determined. **NOTE:** An instruction sheet will accompany each maturity meter. It is important to follow these instructions to initialize the instrument.

For structures, a maturity number can be read directly from the maturity meter or calculated from the temperature readings that shall be obtained from a continual temperature-monitoring device.

Implementation

For pavements, when used at the contractor's option, it is the intent of the procedure to use the maturity method to open the pavement to traffic from the very first day of paving, including the days of development of new curves.

Pavement placed on the first day during development of the strength-maturity curve may be opened when either of the following criteria has been met:

1. The TTF of the slab, or structure, meets or exceeds the opening TTF as determined by the strength-maturity curve being developed.
2. At a particular test age, the average strength of the three beams used for development of the strength-maturity curve meets or exceeds the required opening strength.

For structures, since maturity is to be used on units exposed to flexural loading, the maturity curve should be developed early in the project during placement of concrete exposed to compressive stress. If this is not possible, concrete placed on the same day as development of the strength-maturity curve may be loaded at a particular age using either of the first day placement criteria required for pavements.

Validation

Once per month, validation tests shall be conducted to determine if concrete strength is being represented by the current maturity curve. Cast and cure three (3) beams using the same procedure and manner as used to develop the current maturity curve. Test all three beams as close as possible to the maturity value determined to represent the opening strength of the pavement or the flexural loading strength or form removal strength of the structure.

For pavements, if the average of these tests is within 0.34 MPa (± 50 psi) of the original curve at the TTF the validation beams were tested, the original curve shall be considered validated. If the average value is less than 0.34 MPa (50 psi) of the original maturity curve at the TTF the validation beams were tested, a new maturity curve shall be developed. If the average value is greater than 0.34 MPa (50 psi) of the original maturity curve at the TTF the validation beams were tested, a new maturity curve may be developed.

For structures, if the average of these tests is greater than the original curve at the TTF the validation beams were tested, the original curve shall be considered validated. If the average value is less than the original maturity curve at the TTF the validation beams were tested, a new maturity curve shall be developed.

An example of the Validation of the Maturity Curve is included at the end of this IM. Signed copies shall be provided to the RCE, DME, Central Materials, PCC Engineer, and the contractor.

This validation procedure is intended to be similar to the assurance procedure in that it is not an acceptance test, but merely a check. If the test results indicate a new curve must be developed, this should be done in a timely manner. The curve currently being used shall be continued until new beams can be cast and at that point the implementation procedure described above shall be followed.

Factors Requiring a New Curve

Changes in material sources, proportions, and mixing equipment all affect the maturity value of a given concrete mixture. If the w/c ratio of the production concrete exceeds the w/c ratio of the concrete used to develop the strength-maturity curve by more than 0.02, a new curve shall be developed. Therefore, development of a new maturity curve is generally required for any change to a concrete mix.

Development of a new maturity curve due to material source or proportion changes in a concrete mix may be waived by use of the validation procedure. If the average strength is greater than the original maturity curve at the TTF the validation beams were tested, a new curve will not be required. A new curve will be required if the average strength is less than the original curve at the TTF the validation beams were tested.

Calibration

Maturity meters shall be calibrated yearly to ensure proper temperature sensing. The calibration may be performed at the Central Laboratory, before the start of each construction. To ensure accurate temperature measurement, the maturity meter should also be checked periodically against a certified thermometer or other calibrated meter.

EXAMPLE
Maturity - Field Data

Project : EB-67(23)-55-57 Date Placed: 6/12/2001 Maturity Curve #: 1
 County : SCOTT Mix: C-100-C-15
 Contractor: _____

TTF Required for Opening or Loading: **1500**

SITE 1 Section of Pavement for Opening or Structural Unit for Loading by Maturity: Probe #: 1

Structural Unit or Probe Location From: _____ Probe Location To: _____

Date <i>Enter</i>	Time <i>Enter</i>	Age (hours) <i>Enter</i>	Temp (deg C) <i>Enter</i>	TTF at age (deg C-hr)	Sum TTF (deg C-hr)	Air Temp (deg C) <i>Enter</i>
08/12/99	09:00 AM	0.00	22	0	0	
	01:00 PM	4.00	29	142	142	
	05:30 PM	8.50	25	167	309	
08/13/99	08:00 AM	23.00	19	464	773	
	02:30 PM	28.50	22	198	971	
08/14/99	08:00 AM	47.00	21	551	1522	
	01:30 PM	52.50	20	188	1890	

$$TTF = \left(\frac{Temp + Temp_1}{2} + 10 \right) (Age - Age_1)$$

TTF: **1690** Value in box should be greater than or equal to required TTF.

SITE 2 Section of Pavement for Opening or Structural Unit for Loading by Maturity: Probe #: _____

Structural Unit or Probe Location - From: _____ To Probe Location: _____

Date <i>Enter</i>	Time <i>Enter</i>	Age (hours) <i>Enter</i>	Temp (deg C) <i>Enter</i>	TTF at age (deg C-hr)	Sum TTF (deg C-hr)	Air Temp (deg C) <i>Enter</i>
		0.00		0	0	

$$TTF = \left(\frac{Temp + Temp_1}{2} + 10 \right) (Age - Age_1)$$

TTF: _____ Value in box should be greater than or equal to required TTF.

cc: RCE, Central Materials, Contractor Contractor Representative Agency Representative

Maturity - Field Data

Project : _____ Date Placed: _____ Maturity Curve #: _____
 County : _____ Mix: _____
 Contractor: _____

TTF Required for Opening or Loading : _____

SITE 1 Section of Pavement for Opening or Structural Unit for Loading by Maturity: _____ Probe # _____

Structural Unit or Probe Location From: _____ Probe Location To: _____

Date <i>Enter</i>	Time <i>Enter</i>	Age (hours) <i>Enter</i>	Temp (deg C) <i>Enter</i>	TTF at age (deg C-hr)	Sum TTF (deg C-hr)	Air Temp (deg C) <i>Enter</i>
		0.00		0	0	

$$TTF = \left(\frac{Temp + Temp_{10}}{2} + 10 \right) (Age - Age_{10})$$

TTF: _____ Value in box should be greater than or equal to required TTF.

SITE 2 Section of Pavement for Opening or Structural Unit for Loading by Maturity: _____ Probe # _____

Structural Unit or Probe Location - From: _____ To Probe Location: _____

Date <i>Enter</i>	Time <i>Enter</i>	Age (hours) <i>Enter</i>	Temp (deg C) <i>Enter</i>	TTF at age (deg C-hr)	Sum TTF (deg C-hr)	Air Temp (deg C) <i>Enter</i>
		0.00		0	0	

$$TTF = \left(\frac{Temp + Temp_{10}}{2} + 10 \right) (Age - Age_{10})$$

TTF: _____ Value in box should be greater than or equal to required TTF.

cc: RCE, Central Materials, Contractor _____ Contractor Representative _____ Agency Representative _____

MATURITY - STRENGTH DEVELOPMENT MOR-CPL

COUNTY: Polk
CURVE #: 1
PROJ. #: M-35-5(2)

MONITOR: Jenkins
REINCONTRACTOR: Marriott's

INSPECTOR: Smith
DATE: 05/05/03

BEAM #	LOAD AT BREAK (lbs)	TABLE VALUE (lbs)	BREAK LOCATION (in)	WIDTH (in)	DEPTH (in)	FLEXURAL COEFFICIENT	FLEXURAL STRENGTH CPL (psi)	AGE AT BREAK (days)	TTF CH 1	TTF CH 2	AVERAGE TTF	BEAM TEMP (AVG)
1	Enter	Enter	Enter	Enter	Enter	0.124588	388	Enter	Enter	Enter	Enter	Enter
2	3100	3250	0.5	6.00	6.01	0.124584	405	24	650	650	650	26
3	3050	3150	0.5	6.00	6.02	0.124171	391	24	650	650	650	26
4	3450	3400	0.5	5.98	6.00	0.125418	428	36	800	850	825	24
5	3550	3450	0.5	6.00	6.00	0.125000	451	36	800	850	825	24
6	3500	3425	0.5	6.00	6.00	0.125000	426	36	800	850	825	24
7	4000	4100	0.5	5.98	6.00	0.125418	514	55	1100	1150	1125	22
8	3950	4000	0.5	5.98	6.00	0.125418	502	55	1100	1150	1125	22
9	4000	4100	0.5	6.00	6.00	0.125000	513	55	1100	1150	1125	22
10	4600	4650	0.5	6.00	6.00	0.125000	581	72	1500	1500	1500	23
11	4700	4650	0.5	6.00	6.00	0.125000	585	72	1500	1500	1500	23
12	4750	4700	0.5	5.98	6.00	0.125418	589	72	1500	1500	1500	23

MIX INFORMATION	
AGE	Enter
SLUMP	7.2
W/C	2
W/C	0.41
SEC	G-4WR-C15
FLY ASH SOURCE	Port Neal #4
CEMENT SOURCE	
CEMENT SOURCE	Lehigh
COARSE AGGREGATE SOURCE	Ames Mine
INTERM AGGREGATE SOURCE	
FINE AGGREGATE SOURCE	Vandalia
WATER REDUCER BRAND	Carstad 17
S.M. Rate	2 cc
AIR ADMIXTURE BRAND	Carover 1400
S.M. Rate	6 cc
METHOD OF DEVELOPMENT	Maturity Meter
Estimated Flexural Strength (MOR-CPL)	500 psi
REQUIRED TTF:	1056

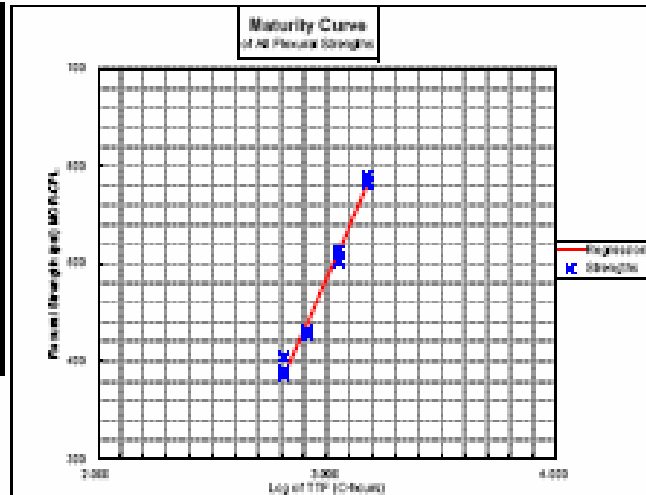

Certified Contractor Representative - _____
Signature

Maturity Curve Reviewed - _____
Testing Engineer

Comments: _____

cc: ROE, DMC, Central Materials, Contractor

VERIFICATION OF MATURITY CURVE																													
CURVE #:	1			MONITOR: Jenkins				INSPECTOR: Smith																					
PROJ. #:	IM-35-5(99)			CONTRACTOR: Manatt's				Verification DATE: 8/11/03																					
BEAM #	LOAD AT BREAK (lbs)	TABLE VALUE (psi)	BREAK LOCATION (in)	WIDTH (in)	DEPTH (in)	FLEXURAL COEFFICIENT	FLEXURAL STRENGTH (psi)	AGE AT BREAK (DAYS)	TTF CH 1	TTF CH 2	AVERAGE TTF																		
1	4000	4100	0.5	6.00	6.00	0.125000	513	39	1000	1000	1000																		
2	3990	4000	0.5	6.00	6.00	0.125000	500	39	1000	1000	1000																		
3	4000	4100	0.5	6.00	6.00	0.125000	513	39	1000	1000	1000																		
AIR: 6.9			Enter																										
SLUMP: 2.5			Enter																										
w/c: 0.42			Enter																										
MIX: C-4WR-C15																													
FLY ASH: Post Neal #4																													
GGBFS: 0																													
CEMENT: Lehigh																													
COARSE AGGREGATE: Ames Mine																													
INTERM. AGGREGATE: 0																													
FINE AGGREGATE: Vandalia																													
WATER REDUCER: Danstard 17																													
Add. Rate: 2 oz.																													
AIR ENTRAINER: Daraveir 1400																													
Add. Rate: 5 oz.																													
Method of Development: Maturity Meter																													
REQUIRED TTF: 1086																													
<div style="display: flex; justify-content: space-between;"> <div style="width: 45%;"> <p>CURVE VERIFICATION</p> <table border="1" style="width:100%; border-collapse: collapse;"> <tr> <td>TTF @ Break</td> <td>1000</td> </tr> <tr> <td>Beam 1</td> <td></td> </tr> <tr> <td>NDR (psi)</td> <td>513</td> </tr> <tr> <td>Beam 2</td> <td></td> </tr> <tr> <td>NDR (psi)</td> <td>500</td> </tr> <tr> <td>Beam 3</td> <td></td> </tr> <tr> <td>NDR (psi)</td> <td>513</td> </tr> <tr> <td>Beam Avg</td> <td></td> </tr> <tr> <td>NDR (psi)</td> <td>508</td> </tr> </table> </div> <div style="width: 45%; text-align: center;"> </div> </div>												TTF @ Break	1000	Beam 1		NDR (psi)	513	Beam 2		NDR (psi)	500	Beam 3		NDR (psi)	513	Beam Avg		NDR (psi)	508
TTF @ Break	1000																												
Beam 1																													
NDR (psi)	513																												
Beam 2																													
NDR (psi)	500																												
Beam 3																													
NDR (psi)	513																												
Beam Avg																													
NDR (psi)	508																												
Calculated psi @ TTF	485	Range	Minimum	435	Curve Verification	OK																							
			Maximum	535																									
<p>Certified Maturity Contractor Representative: _____ Signature _____</p> <p>Maturity Curve Verification Reviewed: _____ Testing Engineer _____</p>																													
<p>Comments: _____</p> <p>Verification strength above the upper limit does not require a new curve.</p>																													
cc: RCE, DME, Central Materials, Contractor																													

Procedure to Determine Datum Temperature Setting for Humboldt Maturity Meters

<u>Key</u>	<u>Displays</u>
Press ENTER	PRESENT VALUES CH 1 Temp: XX
Press REC	RECORDING 1. START
Press REC	SETUP 1. DATUM TEMP
Press ENTER	SETUP DATUM TEMP: -10

If datum temperature is not set to -10° C, press the up (↑) or down (↓) arrows to set the maturity meter to -10. Then press ENTER to save the settings.

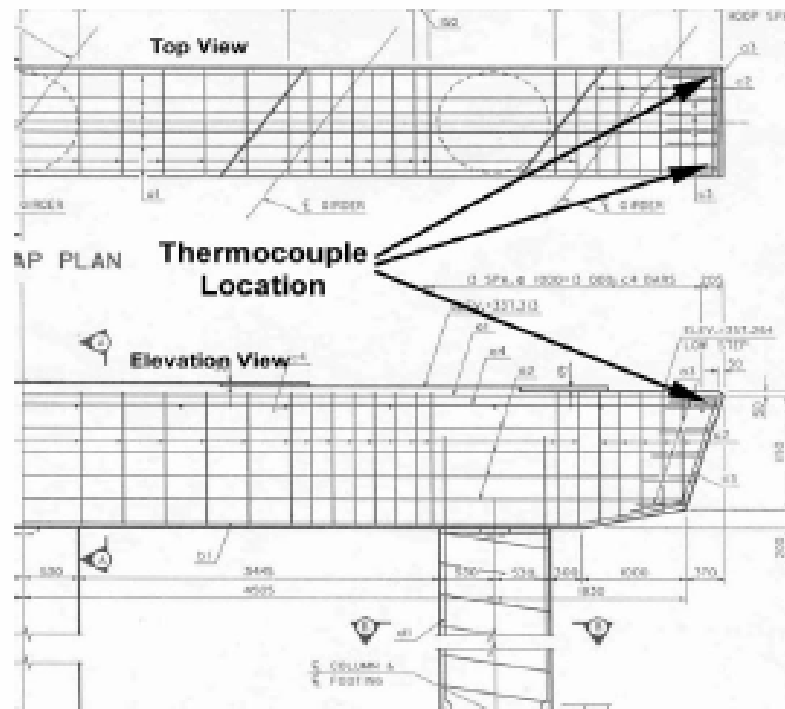

Figure 1. Typical thermocouple location placement in pier cap
Use similar method for thermocouple placement in other structural elements.

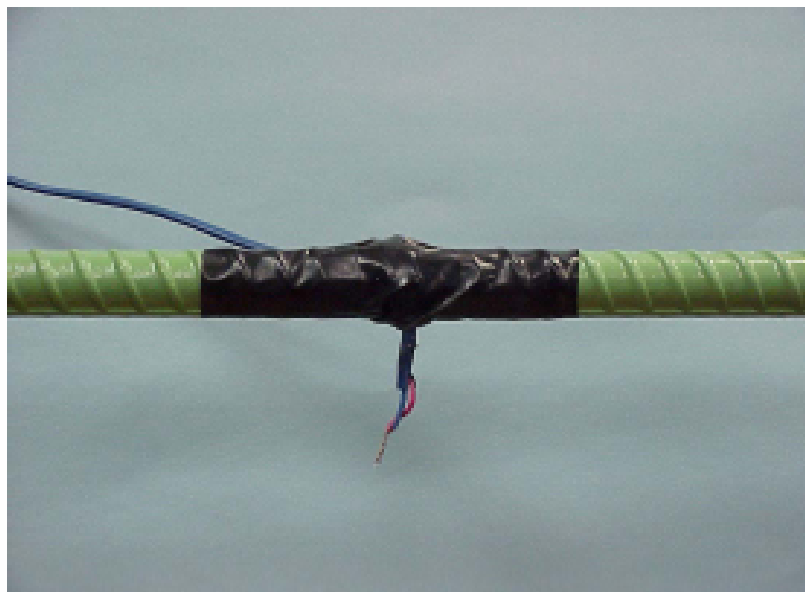

Figure 2. Typical attachment of thermocouple to reinforcing steel

APPENDIX G

INDIANA DOT MATURITY SPECIFICATION ITM 402-04T

The Indiana Department of Transportation maturity specification ITM 402-04T (2004) is presented in the following pages. The specification can be found on the internet at the Indiana Department of Transportation website.

**INDIANA DEPARTMENT OF TRANSPORTATION
MATERIALS & TESTS DIVISION**

**STRENGTH OF PORTLAND CEMENT CONCRETE PAVEMENT (PCCP)
USING THE MATURITY METHOD
UTILIZING THE TIME TEMPERATURE FACTOR METHODOLOGY
ITM 402-04T**

1.0 SCOPE

- 1.1** This test method covers the maturity concept as a non-destructive method to determine in-place concrete flexural strength in the field for opening of PCCP to traffic and during the verification of a new Concrete Mix Design (CMD).
- 1.2** The values stated in either SI metric or acceptable English units are to be regarded separately as standard, as appropriate for a specification with which this ITM is used. Within the text, English units are shown in parenthesis. The values stated in each system may not be exact equivalents; therefore each system shall be used independently of the other, without combining values in any way.
- 1.3** This ITM may involve hazardous materials, operations, and equipment. This ITM does not purport to address all of the safety problems associated with the ITMs use. The ITM user's responsibility is to establish appropriate safety and health practices and determine the applicability of regulatory limitations prior to use.

2.0 REFERENCES**2.1 AASHTO STANDARDS**

- T 23, Making and Curing Concrete Test Specimens in the Field
- T 97, Flexural Strength of Concrete
- T 119, Slump of Hydraulic Cement Concrete
- T 126, Making and Curing Concrete Test Specimens in the Laboratory
- T 152, Air Content of Freshly Mixed Concrete by the Pressure Method
- T 196, Air Content of Freshly Mixed Concrete by the Volumetric Method
- M 241, Concrete Made by Volumetric Batching and Continuous Mixing

2.2 ASTM STANDARDS

- C-1074 Estimating Concrete Strength by the Maturity Method

2.3 ITM STANDARDS

- 403, Water-Cementitious Ratio
- 802, Random Sampling
- 909, Verifying Thermometers

3.0 Terms and Abbreviations. Definitions for terms and abbreviations will be in accordance with 101, except as follows.

- 3.1 Equivalent Age.** The time in days or hours at a specified temperature required to produce a flexural strength equal to the flexural strength achieved by a curing period at temperatures different from the specified temperature.
- 3.2 Maturity Function.** A mathematical expression that uses the measured temperature history of a cementitious mixture during the curing period to calculate a maturity index that is indicative of the flexural strength at the end of that period.
- 3.3 Maturity Index.** An indicator of flexural strength that is calculated from the temperature history of the cementitious mixture by using a maturity function.
- 3.4 Maturity Method.** A technique for estimating concrete flexural strength that is based on the assumption that samples of a given concrete mixture attain equal flexural strengths if they attain equal maturity index values.
- 3.5 Maturity Curve.** A curve established by plotting the flexural strength values vs time-temperature factor values.
- 3.6 Maturity-Strength Relationship.** A relationship between the beam flexural strength and maturity index that is obtained by testing beam specimens whose temperature history up to the time of test has been recorded.
- 3.7 Time-Temperature Factor (TTF).** TTF is a calculated value determined from time and temperature readings used to indicate the flexural strength of the concrete.

4.0 SIGNIFICANCE AND USE

- 4.1** This ITM shall be used to determine in-place flexural strength of concrete for opening of PCCP to traffic.
- 4.2** The hydration of cement and gain in strength of the concrete are dependent on both curing time and temperature. Thus, the strength of the concrete may be expressed as a function of time and temperature. This information may then be used to determine the strength of concrete PCCP without conducting destructive tests.

5.0 APPARATUS

- 5.1 Beam molds:** Beam molds shall have the nominal dimensions of 150 mm x 150 mm x 500 mm (6 in. x 6 in. x 20 in.) in accordance with AASHTO T 23 and T 126.
- 5.2 Flexural Strength Testing Machine:** A testing machine in accordance with AASHTO T 97 used to determine the flexural strength of concrete by breaking simply supported beams loaded at third points.

- 5.3 Maturity Meter:** A device that automatically measures, computes and displays a time-temperature factor.
- 5.4 Hand-held Digital Thermometer:** A verified thermometer having a temperature probe/sensor input connector and a power source. The minimum temperature measuring range shall be 0 °C to 66 °C. The thermometer shall be readable to 0.1 ° C and accurate to 1° C. Thermometers shall be verified in accordance with the applicable requirements of ITM 909.
- 5.5 Temperature Probe/ Sensor:** Thermocouple, thermistor or other device suitable for embedment in the PCCP.
- 5.6 Data Acquisition System:** A device suitable for monitoring and recording the temperature of the concrete. The device may be a system with a computer remote from the job site which reads and logs the probes/sensors through a modem for necessary calculations, or a system with a computer at the job site which automatically reads the probe/sensor signals, calculates the maturity index, and digitally displays the data on demand.
- 5.7 Concrete Mixing Equipment:** The mixers shall be equipped with a metal plate or plates on which are plainly marked the gross volume of the unit in terms of mixed concrete, discharge speed, and the weight-calibrated constant of the machine in terms of a revolution counter or other output indicator in accordance with AASHTO M 241. The capacity of the concrete mixer shall be large enough to place twelve beams at one time and to conduct all other tests.

6.0 GENERAL

- 6.1** This is a three step process.
- 6.1.1** Laboratory procedure in accordance with 7.0.
 - 6.1.2** Field procedure in accordance with 8.0.
 - 6.1.3** Validation procedure in accordance with 9.0.
- 6.2** An Excel based spread sheet computer program, MAT402, is furnished by the Department and shall be used to calculate TTF. The calculation is based on the following equation.

$$\Sigma TTF = \Sigma \left[\left(\frac{T2 + T3}{2} \right) + 10 \right] (A1 - A2)]$$

Where:

- TTF, Time-Temperature Factor in °C x Hours
- A1 - Age in hours
- A2 - Previous age in hours
- T2 - Concrete temperature in °C at measuring age
- T3 - Previous temperature of concrete in °C

7.0 LABORATORY PROCEDURE

- 7.1 Prior to construction a relationship between the TTF and the concrete flexural strength as measured by destructive methods through testing of beams shall be developed in the laboratory using project materials and the project CMD.
- 7.2 Prepare concrete mixture and cast a minimum of twelve beams in accordance with AASHTO T 126. Tests for air content, slump and water-cementitious ratio shall be performed for each batch and recorded in accordance with AASHTO T 152, AASHTO T 119 and ITM 403 respectively.
- 7.3 A temperature probe/sensor shall be inserted near each end of the last beam cast. The temperature/probe sensor shall be placed approximately mid-depth and approximately 75 mm (3 in.) from each end. This beam shall be designated the temperature control beam. This beam shall be the last beam tested for flexural strength. When a wired probe is used, secure the loose end wire of the probe/sensor to the beam box to prevent being inadvertently pulled out of the beam during first 24 h of curing.
- 7.4 The beams shall be covered with wet burlap and polyethylene sheeting upon initial set. The forms, wet burlap and polyethylene sheeting shall be removed 24 h after casting. All beams shall be stored in a testing facility in accordance with 507.09, until each has been tested.
- 7.5 The TTF and flexural strength at four different ages shall be determined and used in the development of the maturity curve. Additional ages may be tested. Three specimens, per age, shall be tested for flexural strength in accordance with AASHTO T 97. The TTF shall be recorded directly using a maturity meter or calculated from a temperature reading using a hand-held thermometer. The first three beams shall be tested for flexural strength 24 h after casting. The remaining tests shall be conducted at 12 h intervals and span a range in flexural strength that includes the desired flexural strength. An alternate testing schedule may be approved by the Engineer.
- 7.5.1 **Maturity Meter.** The Sum of TTF values are computed by the meter. The maturity meter shall remain connected to the temperature control beam until the last TTF is computed.
- 7.5.1.1 One Sum of TTF, per probe, shall be entered in the Maturity Testing Curve Development sheet for the appropriate age. This sheet is found in MAT402, under tab labeled, Curve.
- 7.5.2 **Hand Held Thermometer.** The measured temperature shall be recorded and entered in the TTF worksheet for the appropriate age. This sheet is found in MAT402 under the tab labeled TTF calc. Temperatures for each probe shall be entered in a separate worksheet. The initial temperature of the first three beams shall be recorded at the time of casting. See ATTACHMENT I for a sample sheet.
- 7.5.2.1 The Sum of TTF, for each probe, shall be entered in the Maturity Testing Curve Development Sheet of the appropriate age. This sheet is found in MAT402, under the tab labeled, Curve.

- 7.6 Test the beams for flexural strength in accordance with AASHTO T 97. Record the actual load, average depth, and average width in the Maturity Testing-Curve Development Sheet, for the appropriate age. This sheet is found in MAT402 under the tab labeled, Curve.
- 7.7 MAT402 shall be used to determine the maturity-strength relationship and to develop the maturity curve. The influence of maturity on flexural strength of concrete is CMD specific; therefore, a maturity-strength relationship and maturity curve established for one CMD shall not be used for another CMD.
- 7.8 The computed R^2 value obtained from regression analysis of the maturity-strength relationship shall be 0.950 or higher. The R^2 value can be found on the maturity curve chart. When R^2 value is below 0.950, the TTF value will not be generated. Therefore the maturity curve is unacceptable.
- 7.9 The TTF corresponding to the required flexural strength is calculated by MAT402 and is reported in the Maturity Testing-Curve Development Sheet. This TTF shall be used to determine when the PCCP has reached the required flexural strength. See ATTACHMENT II for a sample.

8.0 FIELD PROCEDURE

- 8.1 Insert the temperature probe/sensor into the plastic concrete prior to curing.
- 8.2 A minimum of two temperature probes/sensors shall be placed within 30 m (100 ft.) of the end of each production day or the last patch of the day. The Contractor may place additional temperature probes/sensors to substantiate required flexural strength at additional locations. The temperature probe/sensor shall not be placed within 1.5 m (5 ft) of transverse joint except for patching. The Engineer will determine the location of the temperature probe/sensor for patching. The tip of temperature probe/sensor shall be placed into the PCCP until the end is at approximately the pavement mid-depth and 0.5 m (1.6 ft) from the edge of the plastic PCCP. Insertion may be accomplished by attaching the tip of the temperature probe/sensor to a 6 mm (0.25 in.) diameter wooden dowel. The wooden dowel shall be removed.
- 8.3 The data may be collected by a maturity meter or a hand-held thermometer. When a wired maturity meter is used, the temperature probe/sensor connector end shall be connected to a maturity meter in accordance with the manufacturer's instructions. When a hand-held thermometer is used, the temperature probe/sensor connector end is connected to the thermometer when a temperature is taken. The initial temperature of the PCCP shall be taken immediately after the temperature probe/sensor is inserted. The initial temperature of the concrete shall be recorded in the TTF Worksheet for each probe. See ATTACHMENT I for a sample of the TTF Worksheet.
- 8.4 The PCCP may be opened to traffic when the average TTF of the two probes representing the end of the day's production reaches the required TTF as determined in accordance with 7.0. The average TTF at an additional location shall be calculated from the TTF of the additional probes at that location.

9.0 VALIDATION PROCEDURE

9.1 Field Validation Tests.

- 9.1.1 Frequency of Validation Testing.** Validation testing is performed to determine if the concrete being produced is represented by the maturity curve for the CMD.
- 9.1.1.1 QC/QA PCCP Pavements.** Validation tests shall be conducted on the third subplot of every fourth lot and on the first subplot of each new CMD in accordance with 501.04.
- 9.1.1.2 PCCP Patching.** Validation tests shall be conducted on the first day of production and once every 600 cyds (500 m³) for each CMD.
- 9.1.2** A minimum of three additional beams shall be cast in accordance with AASHTO T 23 at the time of the QC air content test for subplot.
- 9.1.3** A temperature probe/sensor shall be inserted near each end of the test beam used to monitor temperature. This beam shall be designated the temperature control beam. The temperature probe/sensor shall be placed approximately mid-depth and approximately 75 mm (3 in.) from each end. Insertion may be accomplished by attaching the tip of the temperature probe/sensor to a 6 mm (0.25 in.) diameter wooden dowel. The concrete shall be consolidated around the dowel. When a wired probe/sensor is used secure the loose end wire of the probe/sensor to the beam box to prevent being inadvertently pulled out of the beam during first 24-h of curing. This beam shall be the last beam tested for flexural strength.
- 9.1.4** The beams shall be covered with wet burlap and polyethylene sheeting upon initial set. The forms, wet burlap and polyethylene sheeting shall be removed 24 h after casting. All beams shall be cured in a testing facility in accordance with 507.09, until each has been tested.
- 9.1.5** The TTF of the temperature control beam shall be monitored with a maturity meter in accordance with 7.5.1 or by temperature reading using a hand-held thermometer in accordance with 7.5.2. All three beams shall be tested when the control beam average TTF reaches or exceeds the expected value determined to represent the required flexural strength. The contractor's work schedule will determine time of testing. Report the TTF, the actual load, the depth, the width, and the age for each beam tested in the Maturity Testing-Curve Validation Sheet. This sheet is found in MAT402 under the tabs labeled, val.
- 9.1.6** The average flexural strength of these three beams is calculated and compared to the predicted flexural strength by MAT402. This data is summarized in the Maturity Testing-Curve Validation Sheet. If the average of these tests is within 350 kPa (50 psi) of the original curve for the concrete mixture, the maturity curve is considered validated. If the average value is not within these limits, the maturity process is not valid. A computer printout example for validation of maturity curve is provided by ATTACHMENT III.

10.0 REPORT Copies of all computer printouts, diskettes and field data shall be submitted to the Engineer upon completion of the work. All thermocouple assemblies shall be cutoff flush with the surface of the PCCP upon completion of the work.

ATTACHMENT 1

ITM 402-04T		TTF WORKSHEET			
Indiana Department of Transportation Maturity Testing Time Temperature Factor (TTF) Worksheet <u>ABC CONSTRUCTION</u>					
Contractor: <u>CO</u>					
Project No.: <u>R-99999</u> Description: : : <u>I-999 RECONSTRUCTION</u>	- - - -	Probe No.: Date: <u>10/22/98</u> Time: <u>3:00 PM</u>			
Datum Temp: - 10° C					
Reading					
Number	Date / Time	Temperature	Age	TTF (C°-hrs)	Sum of TTF (C°-hrs)
1	5/5/98 8:00 A	28 ° C			
2	5/6/98 8:00 A	27 ° C	24.0 hrs.	900.0	900.0
3	5/6/98 8:00 P	26 ° C	36.0 hrs.	438.0	1,338.0
4	5/7/98 8:00 A	25 ° C	48.0 hrs.	426.0	1,764.0
5	5/7/98 8:00 P	20 ° C	60.0 hrs.	390.0	2,154.0
6	5/8/98 8:00 A	18 ° C	72.0 hrs.	348.0	2,502.0
7					
8					
9					
10					
11					
12					
13					
14					
15					
16					
17					
18					
19					
22					
23					
Signature 					
<i>Contractor Representative</i>					

ATTACHMENT II
 Indiana Department of Transportation
MATURITY TESTING - CURVE DEVELOPMENT

ITM402-04T

Contractor: ABC CONSTRUCTION CO.

Contract No.: R-99999

Date: 05/05/99

Time: 1:48 PM

Location: I-999 RECONSTRUCTION

Beam Number	Actual Load * (N)	Depth (mm)	Width (mm)	Flexural Coefficient	Flexural Strength (kPa)	Age at Break (hrs.)	Temperature-Time Factor		Average TTF (C ² -hrs)
							Probe1 (C ² -hrs)	Probe 2 (C ² -hrs)	
1	24,500	152	152	0.1301	3,188	24	784	784	784
2	24,500	152	152	0.1301	3,188	24	784	784	784
3	24,500	152	152	0.1301	3,188	24	784	784	784
4	32,000	152	152	0.1301	4,164	36	1,566	1,591	1,579
5	32,500	152	152	0.1301	4,229	36	1,566	1,591	1,579
6	32,250	152	152	0.1301	4,197	36	1,566	1,591	1,579
7	35,600	152	152	0.1301	4,633	48	2,262	2,285	2,274
8	35,000	152	152	0.1301	4,555	48	2,262	2,285	2,274
9	35,000	154	152	0.1268	4,437	48	2,262	2,285	2,274
10	40,000	152	152	0.1301	5,205	60	2,858	2,852	2,855
11	40,500	152	150	0.1319	5,341	60	2,858	2,852	2,855
12	40,000	152	152	0.1301	5,205	60	2,858	2,852	2,855

Plastic Test Results	
Test No:	P7
Air Content:	5.8%
Slump:	51 mm
W/C Ratio:	0.420
Beam Monitoring	
Equipment Used:	Maturity meter
Starting Temperature:	20 ° C

Maturity Criteria for Opening to Traffic (Equivalent to 3792kPa flexural beam strength)	
TTF (C ² -hrs)	1,203
Log of TTF	3.080

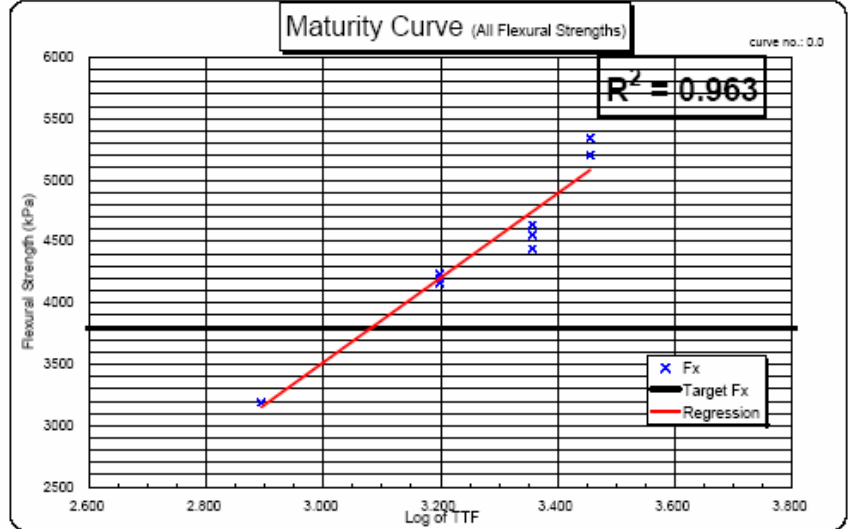

Mix No.: 54648							
Mix Ingredients							
Material	Type	Manufacturer / Plant		Admixture	Type	Source	Dosage
Cement	Type 1	Gray Bros. Industries		Water Reducer	SLS 5500	XL Chemical	14.00 mL/m ³
Fly Ash	Type C	Just Ash		A. E. Agent	SOP2500	XL Chemical	14.00 mL/m ³
Coarse Agg.	#8 Stone	Stone World / (3rd St. Plant)					
Fine Agg.	#23 Sand	Just In Time Sand Co. / (Red River)					

Comments:

Signature _____
 Contractor Representative

ITM 402-04

VALIDATION
 Indiana Department of Transportation
MATURITY TESTING - CURVE VALIDATION

Contractor: ABC CONSTRUCTION CO.

Project No.: R-99999

Description:

I-999 RECONSTRUCTION

Curve No.: 0

Date: 05/10/99

Time: 8:09 AM

Beam Number	Actual Load * (N)	Depth (mm)	Width (mm)	Flexural Coefficient	Flexural Strength (kPa)	Age at Break (hrs.)	Temperature-Time Factor		
							Probe 1 (C ² -hrs)	Probe 2 (C ² -hrs)	Average TTF (C ² -hrs)
1	30,210	152	152	0.1301	3,931	36	1,275	1,275	1,275
2	30,200	152	152	0.1301	3,930	36	1,275	1,275	1,275
3	30,100	152	152	0.1301	3,917	36	1,275	1,275	1,275
					Average	3,926 kPa			
							Average		1275
							Log		3.106

Plastic Test Results	
Test No:	P71
Air Content:	6.0%
Slump:	2 in.
W/C Ratio:	0.396
Beam Monitoring	
Equipment Used:	Digital thermometer
Starting Temperature:	22 ° C

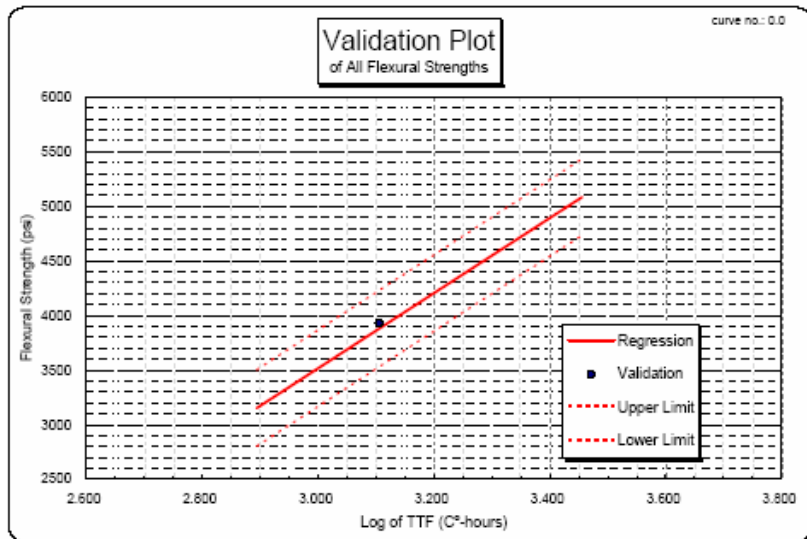

Summary			
Predicted Beam Break*	Actual Beam Breaks (average)	Difference from Target	Result
Lower Limit 3,529 kPa	3,926 kPa	47 kPa above	Within Acceptable Range
Target 3,879 kPa			
Upper Limit 4,229 kPa			

* Predicted beam break results were obtained by plotting the validation TTF on the mix maturity curve (above). Upper and lower limits are as specified for the test method.

Comments:

Signature

Contractor Representative