

**Development and Testing of Open Architecture Composite Structures and
Composite Yarns for Compressive Strength**

by

Uday Bhaskar Sangars

A thesis submitted to the Graduate Faculty of
Auburn University
in partial fulfillment of the
requirements for the Degree of
Master of Science

Auburn, Alabama

May 7, 2016

Keywords: Braiding, O-ACS, Composites, Compressive Strength

Copyright 2015 by Uday Bhaskar Sangars

Approved by

David Beale, Chair, Professor of Mechanical Engineering
Royall Broughton, Jr., Professor Emeritus of Polymer and Fiber Engineering
Sabit Adanur, Professor of Polymer and Fiber Engineering

Abstract

Open Architecture Composite Structures (O-ACS) are truss structures formed by braiding specially designed hybrid yarns, made of high strength fibers, on convex shaped mandrels. Previous studies on them have shown that they exhibit high stiffness to weight characteristics under axial, bending and torsion loading conditions when compared to traditional metal structures. The light weight nature of the structures finds them many potential applications in highly competitive aerospace, automotive and other industries.

This research focuses on improving the load bearing capacity of O-ACS under axially compressive loading. It can be achieved by improving the compressive properties of the axial yarns which are the primary load bearing members of the structure, by using more axial yarns or by optimizing the geometry of structures. Hybrid yarns with different cores (24k, 48k, 84k and 96k carbon fiber towpreg) and different braided jackets (Nylon, polypropelene and carbon fiber towpreg) were manufactured and studied for their compatibility to make O-ACS on conventional maypole braiders. A suitable method which uses acorn nuts to hold the cured yarn samples between them was developed to test the yarns under axial compression. All the manufactured yarns were tested for their compressive strength and their compressive efficiencies were studied to understand how much of the load carrying capacity of the raw fibers is carried over into their hybrid form. Triaxial structures of different architectures and different axial yarns were manufactured. They were tested under axial compression. The structural efficiencies were studied to understand how the architecture of the structures is effecting their load bearing capacity.

Acknowledgments

I would like to thank my family for encouraging me to pursue my goals in every aspect of life and for their constant love and support through thick and thin of my life.

I would like to thank Dr. Beale for giving me an opportunity to be a part of O-ACS research group and his support throughout my research. I am grateful to Dr. Broughton for his valuable guidance and for arranging resources to continue and finish my research. I would also like to thank Dr. Adanur for accepting to be a member of my committee. I must thank Dr. Branscomb for his help with manufacturing structures.

I would like to thank my fellow research students, Shivacharan Mysore, Yang Shen, Shane Furlong, Austin Gurley and Abhishek Bakshi for helping me throughout my research. I would not be able to finish my research without their constant support.

I would also like to thank my friends Kalyan, Abhiram, Uday and Rahul for being there for me whenever I needed them. Without their company my life in Auburn would have been much less exciting.

Table of Contents

Abstract	ii
Acknowledgments	iii
List of Figures	vi
List of Tables	x
1 Introduction	1
1.1 Carbon Fiber Reinforced Polymers	1
1.2 Braiding	3
1.3 Braiding Machines	5
1.4 Open Architecture Composite Structures	8
2 Development and Testing of Hybrid Yarns	9
2.1 Hybrid Yarn - Introduction	9
2.2 Manufacturing of Hybrid Yarn	10
2.2.1 Core	12
2.2.2 Jacket	13
2.2.3 Curing of Yarns for Yarn Compression Testing	14
2.3 Sample Preparation	15
2.4 Test Set Up	15
2.5 Failure Modes	17
2.6 Experiment Results	19
2.6.1 Yarn 6	20
2.6.2 Yarn 15	22
2.6.3 Yarn 16	25
2.6.4 Yarn 17	27

2.6.5	Yarn 18	29
2.6.6	Yarn 20	31
2.7	Yarn efficiency and results comparison	33
3	Development and Testing of O-ACS	37
3.1	Introduction to O-ACS	37
3.2	Manufacturing of O-ACS	40
3.3	Types of Braids	40
3.4	Sample Preparation	44
3.5	Test Set Up	45
3.6	Experimental results	46
3.6.1	6x6x6 Triaxials Made Of Yarn 6	46
3.6.2	4x4x4 Triaxials made of Yarn 18	50
3.7	Failure of Structures	54
3.8	Efficiency of structures	55
4	Joints	57
4.1	Introduction	57
4.2	Shear Debonding of Joints	59
	Bibliography	62
	Appendices	63
A	Carrier selection on 64 carrier machine	64

List of Figures

1.1	Size comparison: Carbon fiber vs human hair	1
1.2	Carbon fibers in an epoxy matrix	2
1.3	3K, 12K and 24K filament carbon fiber towpregs	3
1.4	Braiding of jacket on a hybrid yarn	4
1.5	Horizonatal braiding machine with take-up mechanism	5
1.6	Bobbin and Bobbin carrier	6
1.7	Track plate and the horn gear mechanism behind it	7
1.8	A true triaxial braid, an example of Open Architecture Composite Structures	8
2.1	The components of a hybrid yarn	10
2.2	Steps in the making of Hybrid yarn	11
2.3	Pre-preg tows used in the core	12
2.4	Carrier loading for jacket	13
2.5	Curing of yarns in the oven	14
2.6	Yarn samples	15
2.7	Yarn compression test	16

2.8	A slender column with pinned ends under axial load	17
2.9	Euler curve	18
2.10	Yarn Samples	19
2.11	Images of yarn 6 under microscope	20
2.12	Compression load Vs. length plot of yarn 6	21
2.13	Images of yarn 15 under microscope	22
2.14	Compression load Vs. length plot of yarn 15	23
2.15	60mm yarn 15 sample under compression	24
2.16	Images of yarn 16 under microscope	25
2.17	Compression load Vs. length plot of yarn 16	26
2.18	Images of yarn 17 under microscope	27
2.19	Compression load Vs. length plot of yarn 17	28
2.20	Images of yarn 18 under microscope	29
2.21	Compression load Vs. length plot of yarn 18	30
2.22	Images of yarn 20 under microscope	31
2.23	Compression load Vs. length plot of yarn 20	32
2.24	Yarn efficiencies (Compared with T700S data sheet)	34
2.25	Yarn efficiencies (Compared with pultruded yarn)	35

2.26	Yarn comparison	36
3.1	A biaxial structure	38
3.2	A conventional triaxial structure	38
3.3	A true triaxial structure	38
3.4	Types of braids	40
3.5	The plain braid produced by the 64 carrier machine when all its carriers are loaded	41
3.6	Carriers used to make a 4 CW x 4 CCW braid	42
3.7	A 4 CW x 4 CCW biaxial braid on a circular mandrel	43
3.8	Potting of samples	44
3.9	Compression test set up for O-ACS	45
3.10	6x6x6 Triaxials of different architectures	46
3.11	Compression load vs Compression plots of 6x6x6 TTs	48
3.12	Compression load vs Compression plots of 6x6x6 DAs	48
3.13	Compression load vs Compression plots of 6x6x6 CTs	48
3.14	Comparison of TTs made of Yarn 6 with different number of axial yarns	49
3.15	6x6x6 Triaxials of different architectures under Compressive loading	49
3.16	4x4x4 CTs of different span lengths	50
3.17	Compression load vs Compression plots of 84k 4x4x4 CTs	51

3.18	Compression load vs Compression plots of 84k 4x4x4 CTs	52
3.19	Comparison of 4x4x4 CTs with different axial yarns	53
3.20	Comparison of 4x4x4 CTs with different span lengths	53
3.21	A broken axial yarn after compression test of structure	54
3.22	Comparison of structural efficiencies of different O-ACS	55
4.1	A helical-helical joint in a true triaxial open structure	57
4.2	A joint cut out from the structure for testing	58
4.3	Experiment set up for the shear tests	59
4.4	A joint with extra glue applied on it	60
4.5	Failure of joints: with glue vs without glue	61
A.1	Plain braid produced by machine when 64 carriers are loaded	64
A.2	16x16 conventional biaxial braid	65
A.3	8x8 conventional biaxial braid	65
A.4	4x4 conventional biaxial braid - Type 1	66
A.5	4x4 conventional biaxial braid - Type 2	66

List of Tables

2.1	Properties of yarn 6	20
2.2	Compression test results of yarn 6	21
2.3	Properties of yarn 15	22
2.4	Compression test results of yarn 15	23
2.5	Properties of yarn 16	25
2.6	Compression test results of yarn 16	26
2.7	Properties of yarn 17	27
2.8	Compression test results of yarn 17	28
2.9	Properties of yarn 18	29
2.10	Compression test results of yarn 18	30
2.11	Properties of yarn 20	31
2.12	Compression test results of yarn 20	32
3.1	Construction of samples	47
3.2	Compression test results of 6x6x6 triaxials	47
3.3	Geometry and Yarns used in 84k 4x4x4 CTs	50
3.4	Compression test results of 84k 4x4x4 CTs	51
3.5	Geometry and Yarns used in 84k 4x4x4 CTs	52
4.1	Failure of joints without extra glue	60
4.2	Failure of joints with extra glue	61

List of Abbreviations

AU	Auburn University
CF	Carbon fiber
O-ACS	Open Architecture Composite Structures
CW	Clockwise
CCW	Counter clockwise
TT	True Triaxial
CT	Conventional Triaxial
DA	Double Axials

Chapter 1
Introduction

1.1 Carbon Fiber Reinforced Polymers

A carbon fiber is a long thin strand of material about 5–10 microns in diameter and composed mostly of carbon atoms. In Figure 1.1, the size of a carbon fiber is compared with human hair [1].

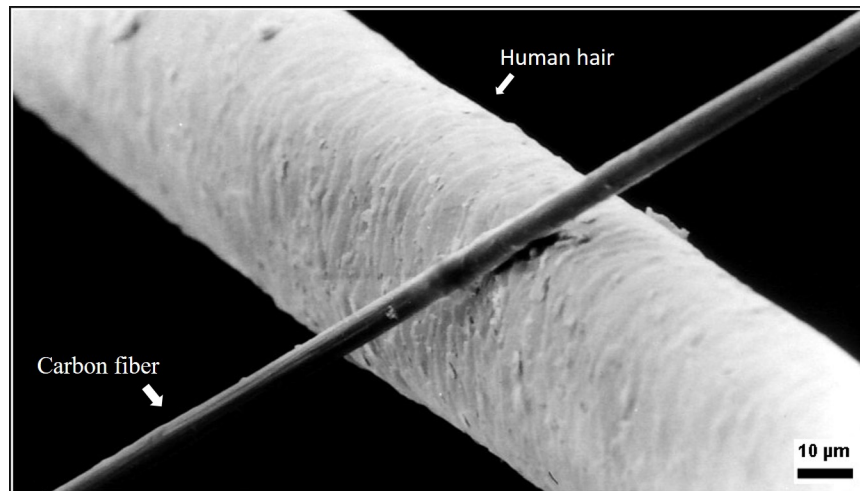

Figure 1.1: Size comparison: Carbon fiber vs human hair

The crystal alignment of carbon atoms parallel to the axis of the fiber makes the fiber incredibly strong in the fiber direction for its size. The greater the alignment of the carbon atoms to the fiber axis, the stronger the fiber. The high modulus of the fiber also stems from the same fact. Similarly, the electrical and thermal conductivities are higher along the fiber axis, and coefficient of thermal expansion is lower along the fiber axis [2].

Fibers are generally useless as structural materials unless they are held together in a structural unit with a binder. Fibers alone cannot support longitudinal compressive loads

and their transverse mechanical properties are seldom as good as their corresponding longitudinal properties. Thus they are usually combined with other materials to form composites. A composite is a material made from two or more constituent materials with significantly different properties that, when combined, produce a material with properties different from the individual components. The individual components remain separate and distinct within the finished structure. In this case the composite consists of two parts: a matrix and a reinforcement. Figure 1.2 is an image of carbon/epoxy composite showing actual fiber packing geometry at 400x magnification [3].

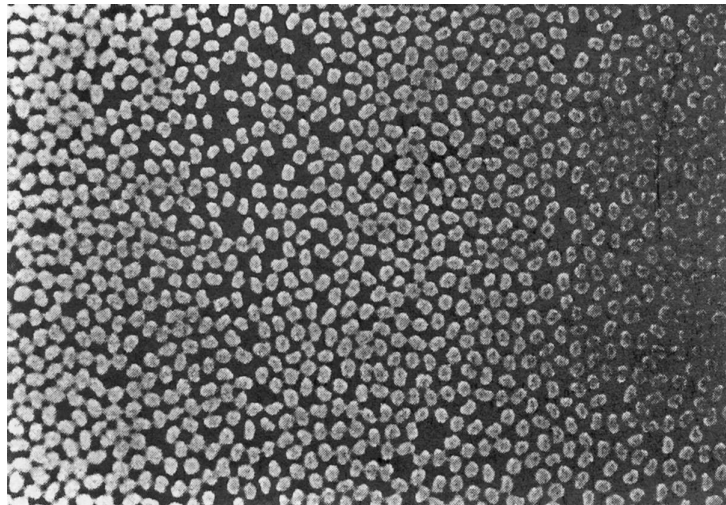

Figure 1.2: Carbon fibers in an epoxy matrix

The matrix is usually a polymer resin, such as epoxy and carbon fibers reinforce the matrix. Together they are known as carbon fiber reinforced composites or carbon fiber reinforced polymers (CFRP). The resultant composite material properties depend on the two constituent element properties. While fibers provide the strength, the matrix keeps all the fibers together. The matrix also serves to protect the fibers from external damage and environmental attack. Filler particles are also commonly used in composites for a variety of reasons such as weight reduction, cost reduction, flame and smoke suppression, and prevention of ultraviolet degradation due to exposure to sunlight [3].



Figure 1.3: 3K, 12K and 24K filament carbon fiber towpregs

Figure 1.3 shows UF3330 [4] epoxy impregnated carbon fiber tows by TCR Composites which were used in this research to make the composite yarn.

1.2 Braiding

The braid is a textile structure produced by the intertwining of three or more parallel strands together. The art of braiding dates back to the early days human civilization [5]. It has been a very important process throughout the history of textiles in transforming fibers into more useful forms. Smaller, natural-fiber strands were braided in order to produce larger, stronger structures such as rope. For a long time braiding remained a hand skilled art. The development of braiding machine in the 18th century made it possible to produce various new forms at a faster speed [5].

Braiding is a key technique to produce composites at lower costs. The process is suitable for rapid and limited production runs. Braids are extensively used in a variety of industrial applications, including aerospace, marine, automotive, fashion, and sports equipment. Some

examples of braided structures include aircraft propellers, rocket nozzles, hockey sticks and turbine fan casings [6]. Figure 1.4 shows the braiding of jacket on a carbon fiber core to make a hybrid yarn.

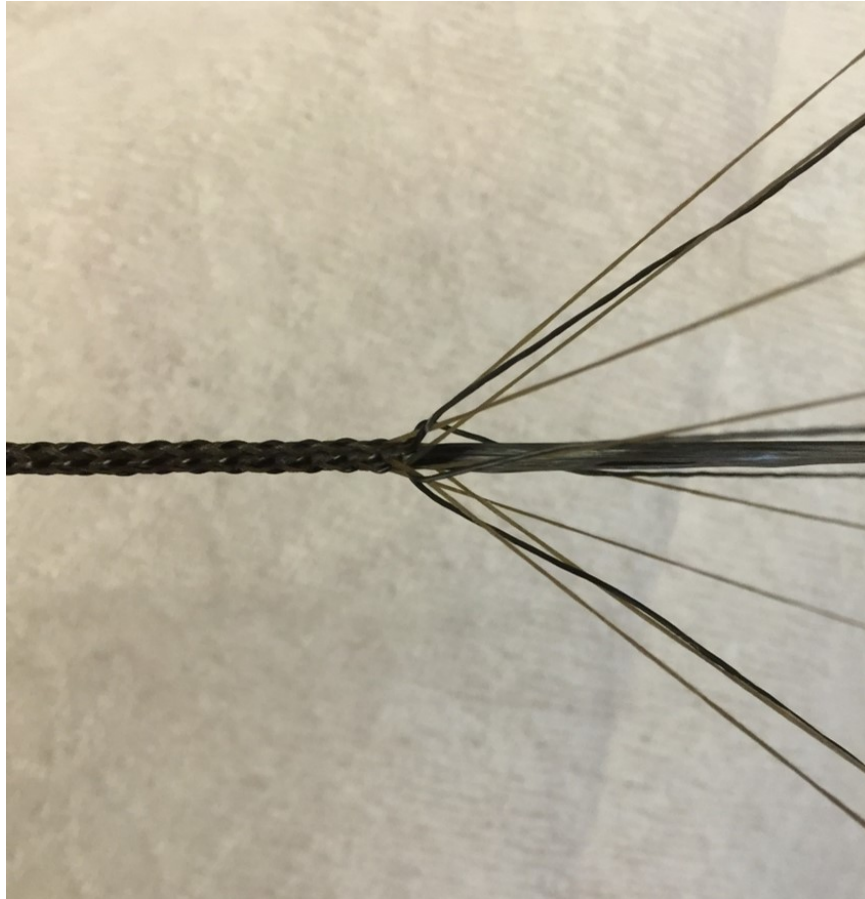

Figure 1.4: Braiding of jacket on a hybrid yarn

1.3 Braiding Machines

Braiding machines can be broadly divided into two groups [5], and can be described in terms of the direction in which the braid is produced. When the machine has a vertical track plate, the braid is produced in the horizontal direction and the machine is called Horizontal braiding machine. The vertical braiding machines will have their track plates horizontally and they produce a vertical braid.

Figure 1.5 is a schematic of the setup used in this research showing a horizontal braiding machine, take-up mechanism and the creel at the back that holds the spools of pre-preg tow [7].

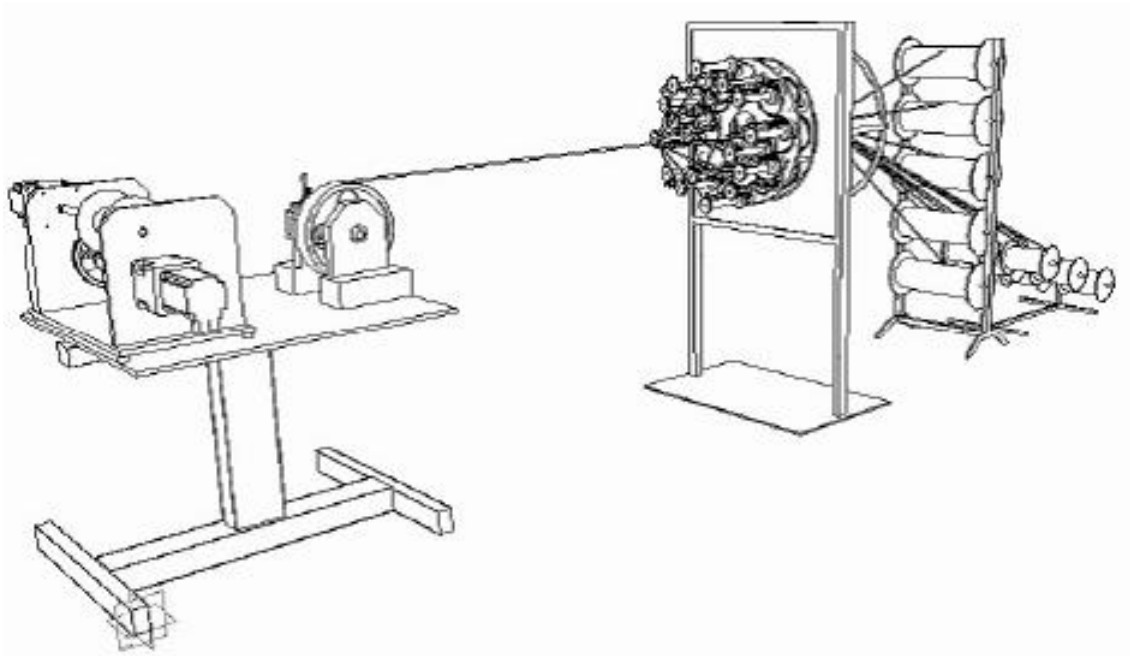

Figure 1.5: Horizontal braiding machine with take-up mechanism

The most common type of yarn supply packages for braiding machines are bobbins. The yarn which is selected to make the structure is wound on several bobbins using winding machines. The bobbins are then loaded onto bobbin carriers.

The carriers consist of a track follower, a bobbin spindle, a tensioning mechanism, and a let-off mechanism. The compression spring in the carrier, which is interchangeable,

controls the tension in the yarn. It is important to select the appropriate compression spring depending on the type of yarn selected. Figure 1.6 shows the components of a bobbin carrier used on a maypole braider [6].

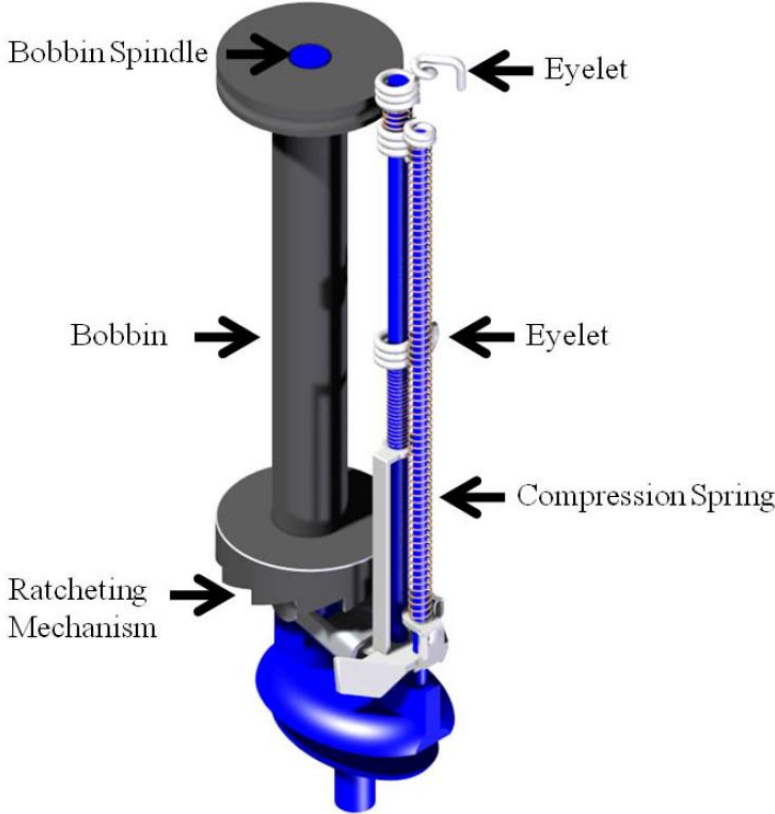

Figure 1.6: Bobbin and Bobbin carrier

The carriers are propelled along the slot by means of horndogs which are attached by the same stud to a horngear. The horndog is a metallic disk with notches cut in its periphery. These notches transfer the carrier, through the track follower, from one horngear to the next. When a carrier reaches a track intersection, it is forced by the shape of the track to transfer from one horngear to the next. This transfer process is the heart of the braiding process.

The number of slots in the horndog determines the type of interlacing which can be produced in the braiding machine. Figure 1.7 shows the track plate and the horn gear mechanism behind it.

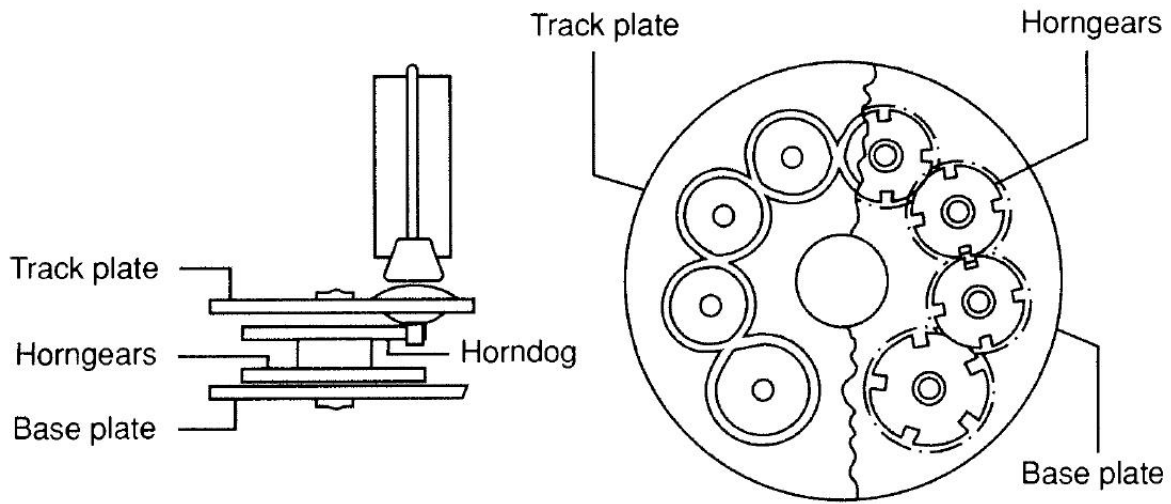

Figure 1.7: Track plate and the horn gear mechanism behind it

The horn gears are located below the track plate and are connected in series. The number of horn gears determines the size of the braiding machine. The track provides the mechanism for determining the carrier path. The track is typically cut in a multiple figure eight pattern, and provides the resistance to the carrier required to keep the track follower of the carrier in the horndogs. As the horn gears rotate and propel the carriers along the track, the yarns interlace and a braid is formed. The points where the yarns form a braid is called the fell point. The take-up mechanism pulls the yarn as it is braided and wraps it around the spool.

1.4 Open Architecture Composite Structures

The need for strong yet light structures is increasing in aerospace, automotive and many other engineering applications. Truss structures are known for their higher specific strength and specific stiffness properties compared to continuous structures. Open architecture composite structures (O-ACS), as shown in Figure 1.8, are truss structures made by braiding composite yarns on a cylindrical mandrel. It is also possible to make them on other convex shaped mandrels like elliptical or hexagonal mandrels. The structures exhibit high strength to weight and high stiffness to weight characteristics. They can be produced in short runs and are suitable for rapid manufacturing.

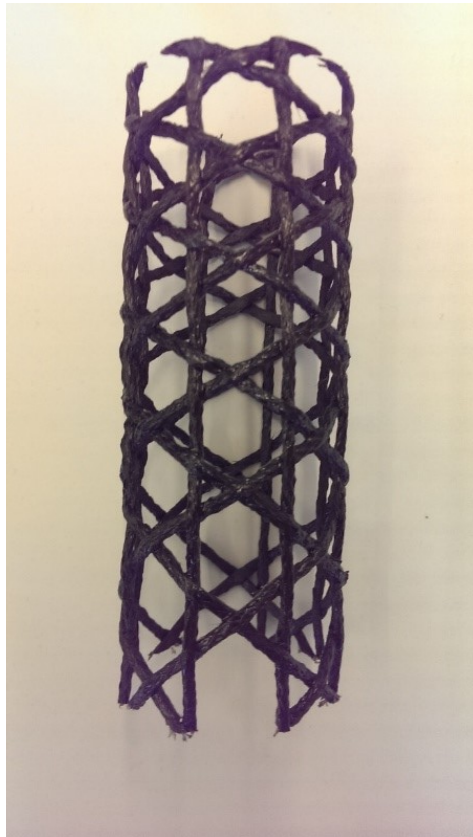

Figure 1.8: A true triaxial braid, an example of Open Architecture Composite Structures

Chapter 2

Development and Testing of Hybrid Yarns

2.1 Hybrid Yarn - Introduction

A yarn is a continuous strand of textile fiber or filaments in a form suitable for knitting, weaving or intertwining to form textile fabrics [5]. A yarn can be made in different ways. The fiber material properties and the resulting yarn geometry (twist, denier etc.) determine the performance properties of a yarn and the processing methods and applications for which a yarn is suited.

Carbon fiber yarns are pre-impregnated with a resin system before they are used for industrial applications. They cannot directly be used to braid preforms on the braiding machine. They are tacky, not easily braid-able and cause problems while machining. The yarn selected for braiding is wound on bobbins which are mounted on the bobbin carriers. A pre-impregnated yarn has to pass over the pulleys, through the eyelets to the fell point in the braiding process. The yarn also undergoes tension while it is pulled for braiding. The resin in the yarns causes friction between them when two yarns cross each other while braiding. The carbon fiber tows often fail under these circumstances and leave residue on the machinery.

A hybrid yarn consists of a protective outer jacket on the pre-impregnated carbon fiber core yarn. The jacket is a braid on the core. The jacket keeps all the core fibers together, protects them while braiding and minimizes the problem of residue transfer to the machinery. Figure 2.1 shows the components of a hybrid yarn.

The outer jacket can have either a biaxial architecture or a triaxial architecture. The jacket must be such that the core does not slip inside it. The jacket may be an open architecture which reduces material and promotes bonding between adjacent yarns.

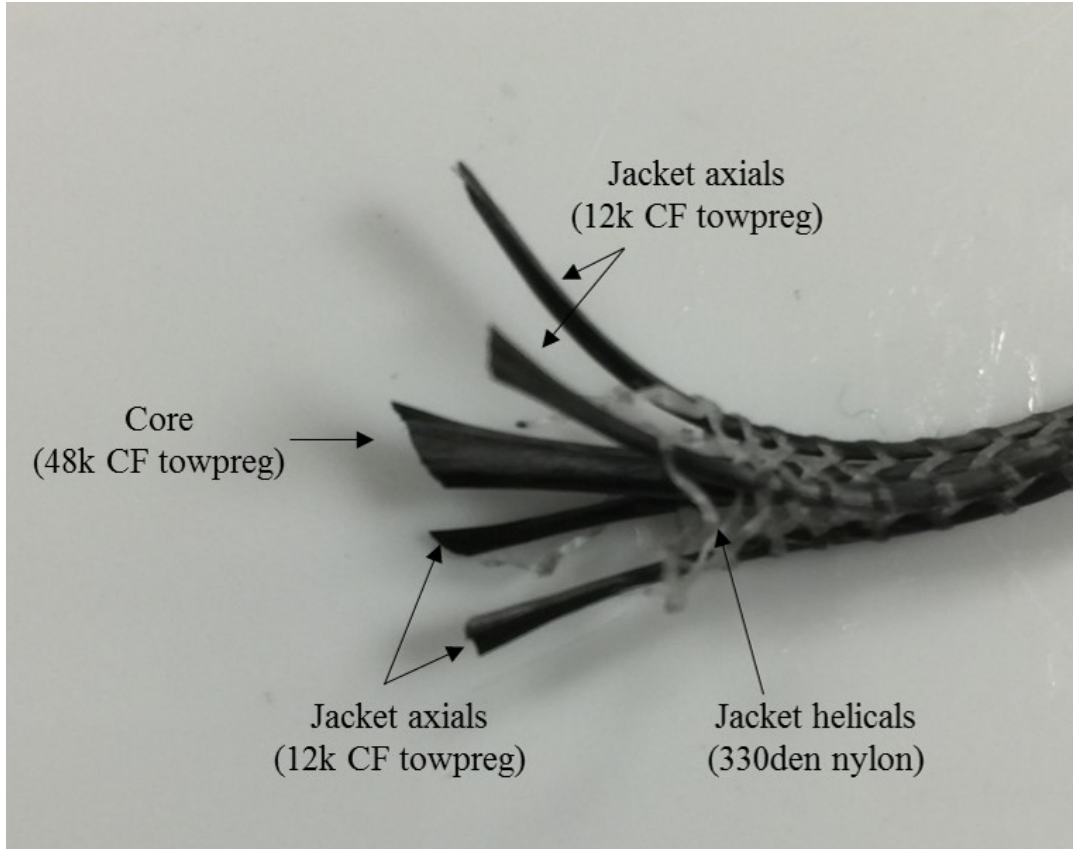

Figure 2.1: The components of a hybrid yarn

2.2 Manufacturing of Hybrid Yarn

The hybrid yarns are manufactured on the maypole braiding machine available in the Auburn University's Polymer & Fiber Department. The laboratory has three maypole braiders. One has 32 bobbin carriers on it and is used to make yarns because of its suitable take-up mechanism. The other two have 64 and 144 bobbin carriers on them and are mostly used to make O-ACS on them. Figure 2.2 shows the steps followed to make a hybrid yarn.

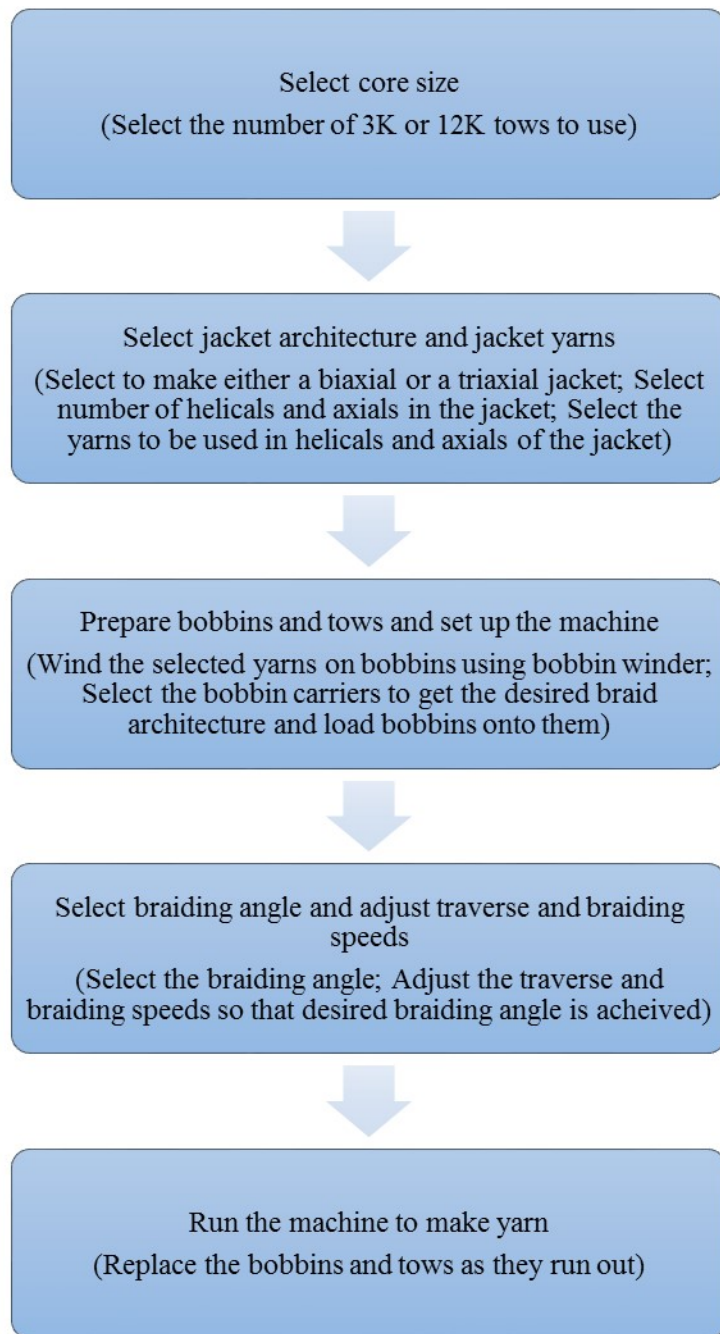

Figure 2.2: Steps in the making of Hybrid yarn

2.2.1 Core

Carbon fiber core is the primary load bearing component in the hybrid yarn. Though adding more filaments to the core increases the load bearing capacity of the yarn, it is not always recommended to do so. As the diameter of the yarn increases the braidability of it on the conventional braiding machines decreases, as the bobbin carriers on them are meant for textile yarns of lower denier count.

Figure 2.3 shows the tow creel on which CF pre-preg tows are mounted. The polyethylene foam which is used to mount the tows on dowels, the dowels and the pipe clamps holding the dowels to the frame should be of right size and fit snugly on each other. This ensures the right amount of tension and smooth release of pre-preg yarn to the machine while braiding.

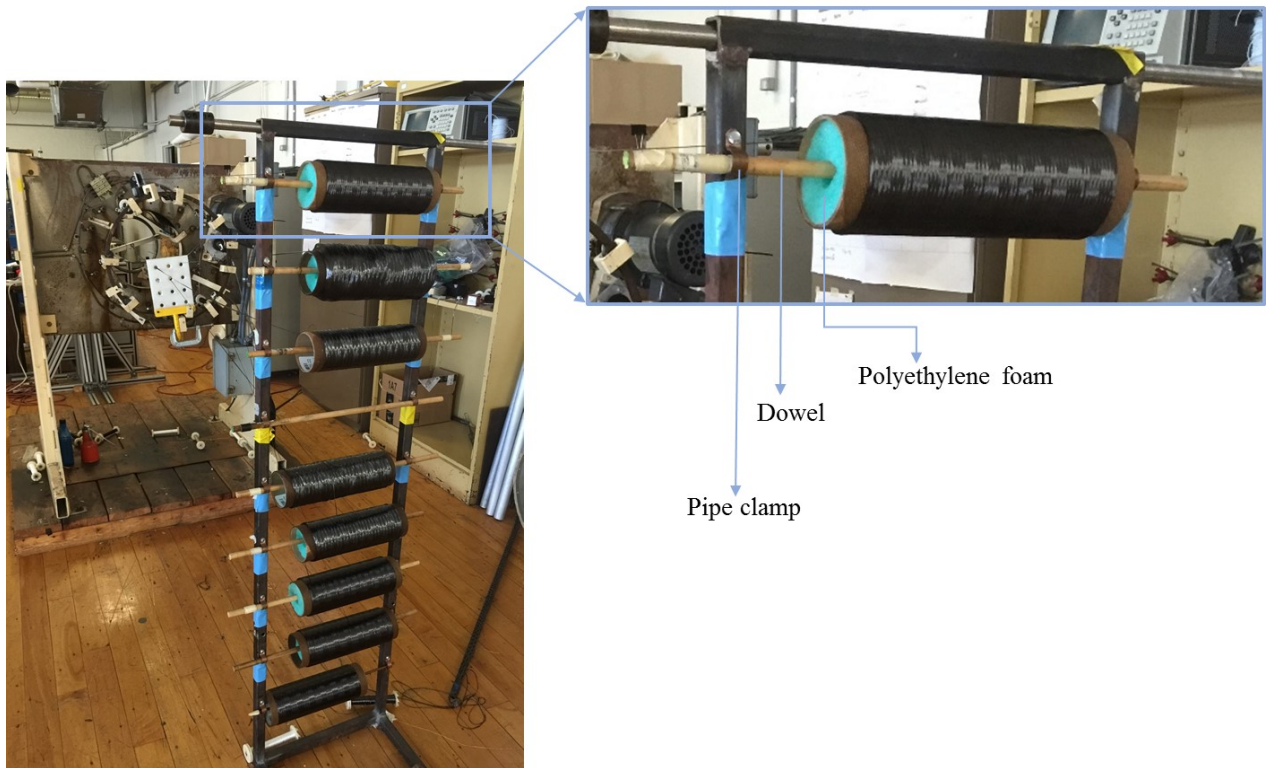

Figure 2.3: Pre-preg tows used in the core

2.2.2 Jacket

The jacket is either a triaxial or a biaxial braid on the core. A jacket which has two sets of helical yarns spiraling around the core while interlacing whenever they meet is called a biaxial braid. A biaxial braid with axial yarns running along the length is a triaxial braid. It was observed that the yarn cross section varied with the type of jacket it had. While biaxial jackets resulted in a circular yarn, triaxial jackets with four axials resulted in a more square cross section of the yarn. Circular yarns are more suitable to make O-ACS than square yarns as the latter get twisted along the length while braiding. Figure 2.4 shows the set up of bobbins on 32 carrier maypole braiding machine to make Yarn 6.

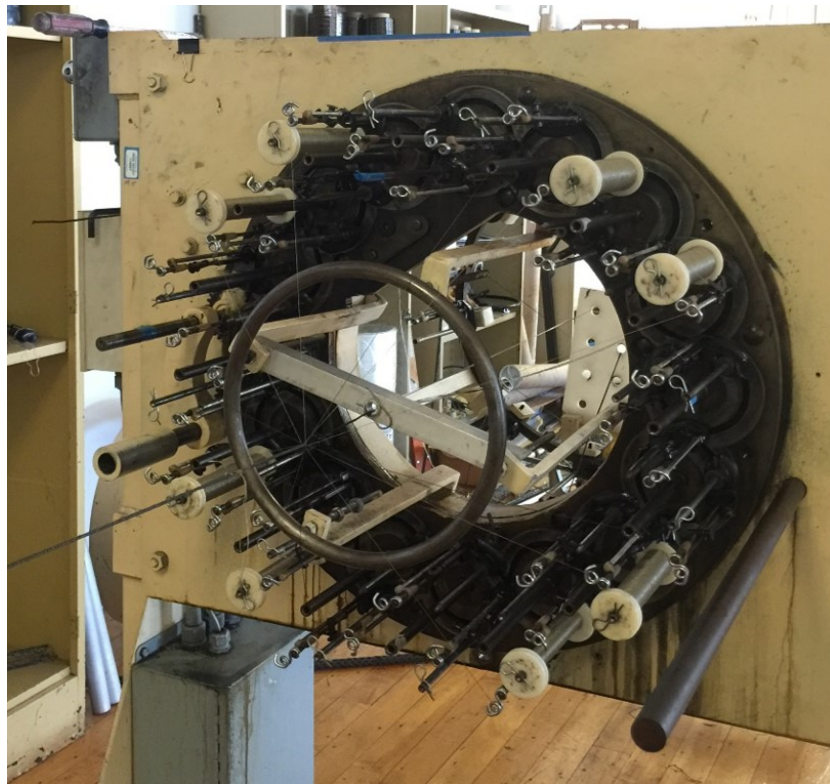

Figure 2.4: Carrier loading for jacket

2.2.3 Curing of Yarns for Yarn Compression Testing

The glass transition temperature, T_g , of the UF3330 resin, the resin with which the T700S and T300 carbon fiber tows are impregnated, is 248°F [4]. The hybrid yarns are cured in the oven at 270°F for 4 hours as recommended by the towpreg manufacturer. Weights are tied to the bottom of the yarns, as shown in the Figure 2.5, to keep them straight. Care should be taken so that the yarns do not twist while curing.



Figure 2.5: Curing of yarns in the oven

2.3 Sample Preparation

The cured yarns are taken out of the oven and are cut into small pieces of required lengths. Samples of lengths varying from 10mm to 80mm are made. Each end of the sample is inserted into a cap nut (acorn nut), which has same internal diameter as the diameter of the yarn. Then the ends are glued using 3M DP460 [8] epoxy adhesive. At least two samples of each length are prepared for testing.

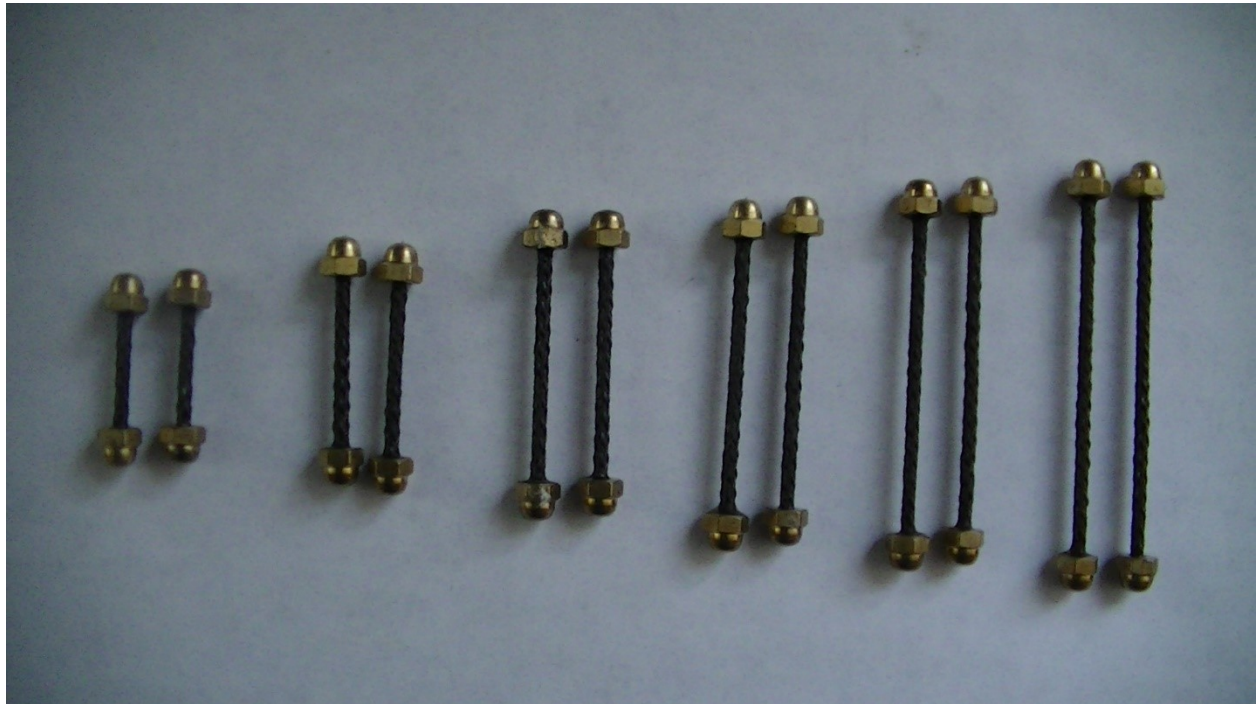

Figure 2.6: Yarn samples

2.4 Test Set Up

All the testing was done on Instron universal testing machine available in the Polymer & Fiber department of Auburn University. As shown in Figure 2.7 flat head pocket cap screws, which are screwed to cylindrical fixtures, were used on both sides to hold the samples for testing on the machine.

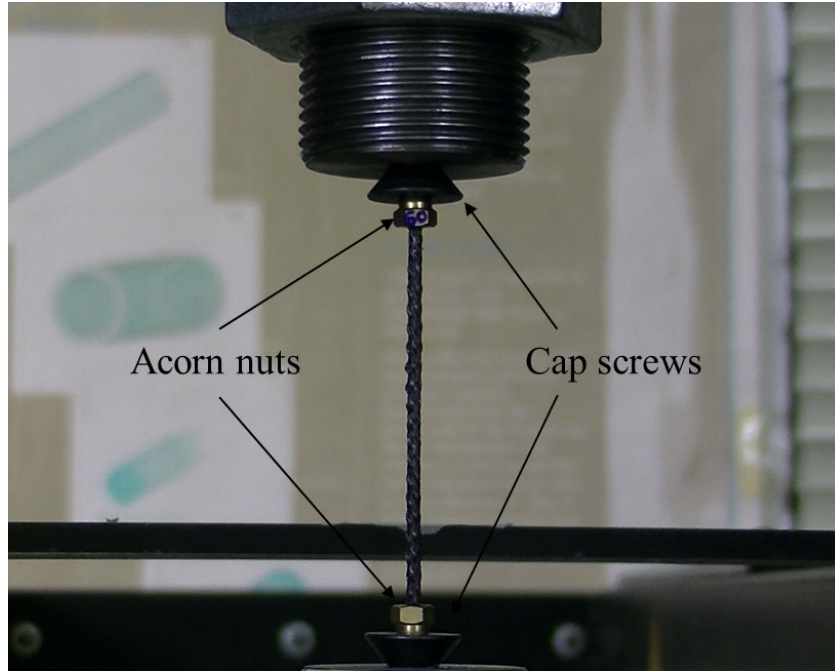

Figure 2.7: Yarn compression test

The crosshead of the Instron was moved upwards at a constant speed of 1mm/min to compress the test samples. The samples failed either by crushing or by buckling which is described in the next section.

2.5 Failure Modes

Structures under compression may fail in a variety of ways, depending upon the type of structure, the conditions of support and the materials used. When a compression member is very short, it fails by crushing. But when a compression member is relatively long and slender, it may deflect laterally and fail by bending rather than failing by direct compression of the material. When lateral bending occurs, we say that the structure has buckled. If the axial load is increased the lateral deflections will increase too. Eventually the structure will completely collapse. Buckling is one of the major causes of failures in structures, and therefore the possibility of buckling should always be considered in design.

The slenderness of columns is measured by a parameter called Slenderness ratio which is defined as the ratio of the length of a column to the radius of gyration of its cross section. If 'L' is the length and 'r' is the radius of cross section of the yarn then ' L/r ' is the slenderness ratio of it. If the yarn has a square cross section with 'a' as the side then ' L/a ' is the slenderness ratio of the yarn.

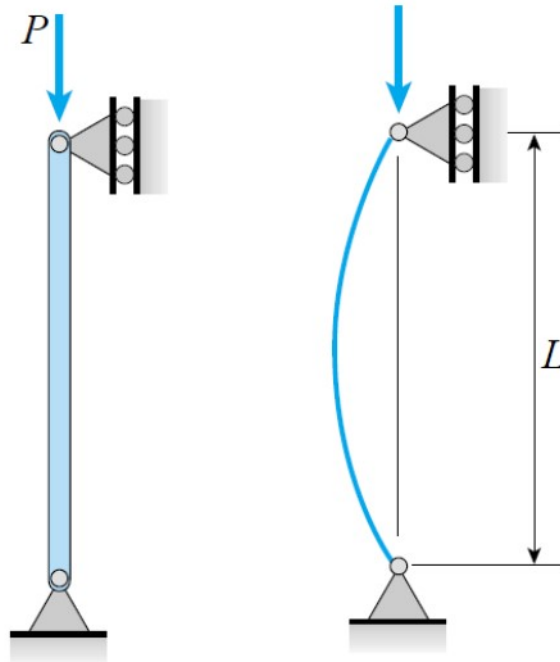

Figure 2.8: A slender column with pinned ends under axial load

When an axial load P is applied at one the end of a slender column with pinned ends, as shown in Figure 2.8, it undergoes direct axial compression. As the load increases the column gets unstable and may start buckling and the load at which buckling starts is called Critical load (P_{cr}).

If $P < P_{cr}$, the structure is stable

If $P > P_{cr}$, the structure is unstable

According to the theory of Euler buckling the critical load of a column with pinned ends is $P_{cr} = \pi^2 EI/L^2$, where 'E' is the Young's modulus and 'I' is the moment of inertia about principal axis

The critical stress is the compressive stress on the cross section of the yarn when the load reaches critical load. The graph of this stress against the slenderness ratio is a curve known as Euler's curve. Euler's theory describes the behavior of ideal column under compression. Often in real conditions the columns are not perfectly straight, support conditions are imperfect and the load is not exactly at the center. The secant formula considers the eccentricity of the loads and predicts that the load carrying capacity of the columns decreases significantly because of the imperfections.

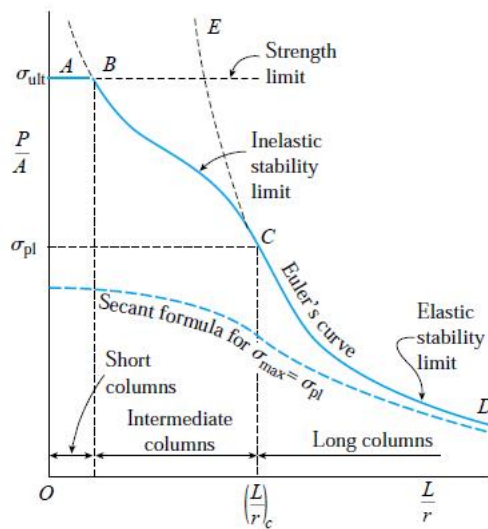

Figure 2.9: Euler curve

2.6 Experiment Results

Different types of hybrid yarns, as shown in Figure 2.10, are manufactured and tested under compression. The total amount of carbon fiber in the yarn, amount of carbon fiber in the core, amount of carbon fiber in the jacket, materials used the jacket, jacket architecture are varied to understand how each parameter effects the compressive strength of the yarn.

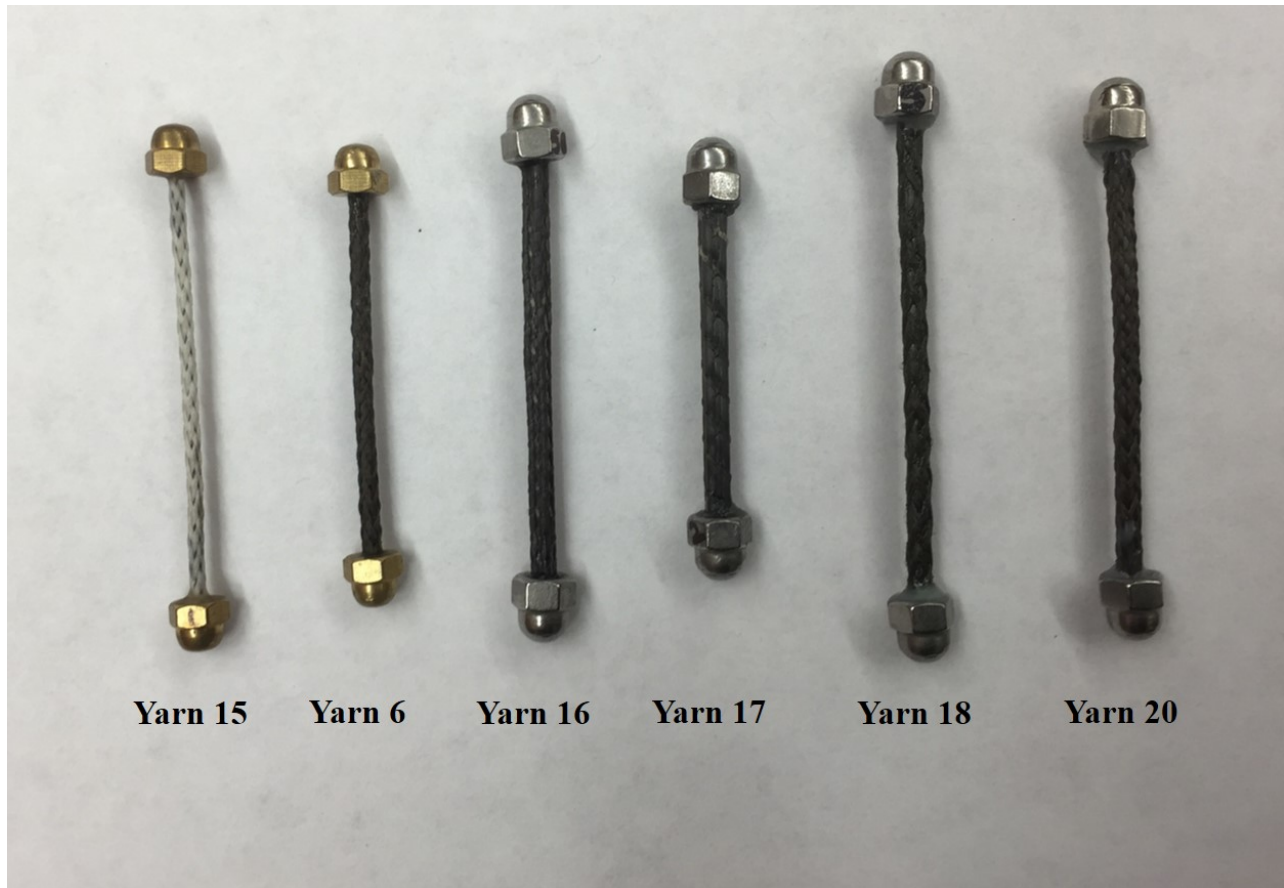

Figure 2.10: Yarn Samples

2.6.1 Yarn 6

Researchers in Auburn University have previously developed a yarn with 48k CF at the core, four 3k CF towpregs in the jacket and 500 denier textured nylons as helicals [9] [10]. The axial, flexural and torsional stiffnesses of the yarn were determined before [9]. In this section the yarn is studied under compression. Figure 2.11 shows the images of jacket and cross section of yarn viewed under microscope. The yarn was observed to have a square cross section of 2.3 mm side and the remaining properties of yarn are listed in Table 2.1.

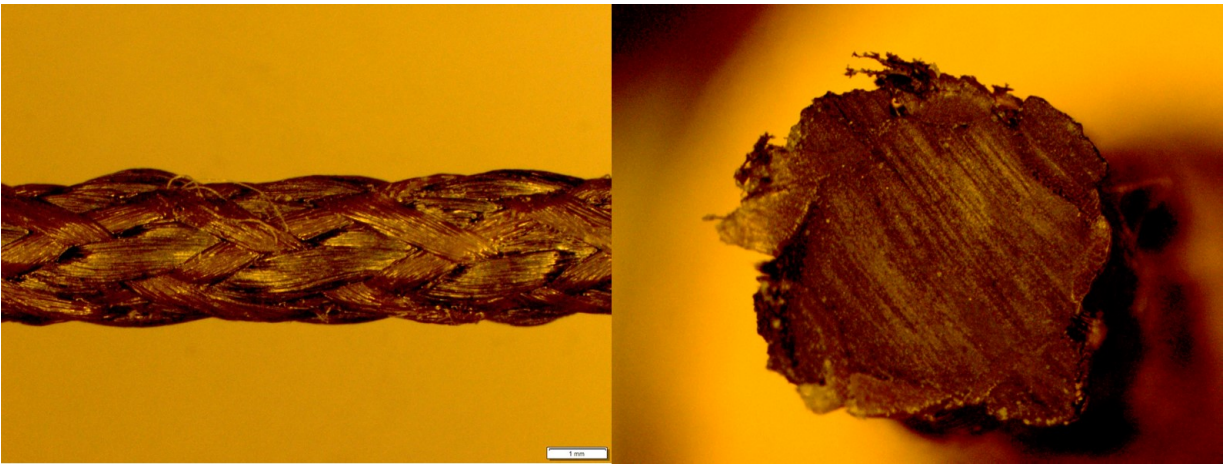

Figure 2.11: Images of yarn 6 under microscope

<i>Core</i>	4 x 12K Prepreg
<i>Jacket</i>	
Axials	4 x 3K Prepreg
CW	4 x 500 den textured nylon
CCW	4 x 500 den textured nylon
Architecture	True Triaxial
Machine	32 Carrier
Geometry	
Cross Section	Square
	2.3mm side
Linear density	5.681gm/m

Table 2.1: Properties of yarn 6

Samples of lengths between 11 and 60 mm were prepared and tested under compression. Table 2.2 shows failure load of each sample and Figure 2.12 shows how the failure load is changing with changing sample length. Samples of length 36mm and over were observed to buckle.

Sample Length (mm)	Sample No	Compressive Load (N)	Average Compressive Load (N)
11	Sample 1	2210.7	1986.3
11	Sample 2	1761.8	
19	Sample 1	1560.7	1539.3
19	Sample 2	1518.0	
27	Sample 1	1202.8	1202.8
36	Sample 1	1014.3	963.0
36	Sample 2	911.7	
43	Sample 1	554.8	626.4
43	Sample 2	697.9	
51	Sample 1	449.9	449.9
60	Sample 1	514.2	491.2
60	Sample 2	468.1	

Table 2.2: Compression test results of yarn 6

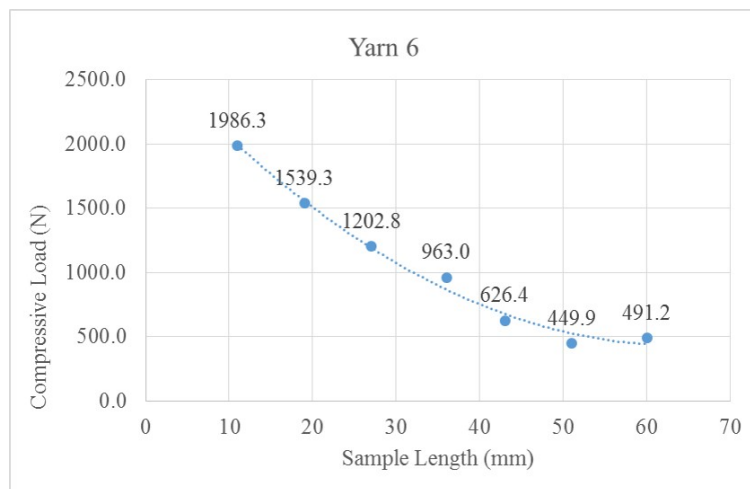

Figure 2.12: Compression load Vs. length plot of yarn 6

2.6.2 Yarn 15

Yarn 15, as shown in Table 2.3, was made with only 24k CF at the core and no CF in the jacket. This yarn has least amount of total carbon fiber among all the different types of yarns tested. Polypropylene yarns were used to make the jacket of this yarn and the absence of CF axials in the jacket resulted in a circular cross section of the yarn as shown in Figure 2.13.



Figure 2.13: Images of yarn 15 under microscope

Core	2 x 12K TCR TowPreg
Jacket	
Axials	None
CW	4 x 940 den polypropylene
CCW	4 x 940 den polypropylene
Architecture	Biaxial
Machine	16 Carrier
Geometry	
Cross Section	Circular
	1.93mm dia
Linear density	2.856gm/m

Table 2.3: Properties of yarn 15

Samples of lengths between 10 and 60 mm were prepared and tested under compression. It was observed that the samples of length 32mm and over were failing by buckling. Figure 2.15 shows a 60mm sample which was buckled under the application of load. It was also observed that the polypropylene jacket was slipping over the CF core freely. Table 2.4 and Figure 2.14 show the failure loads of each sample and how the load bearing capacity is decreasing with increase in the sample length.

Sample Length (mm)	Sample No	Compressive Load (N)	Average Compressive Load (N)
10	Sample 1	674.5	630.3
10	Sample 2	586.1	
16	Sample 1	469.8	507.1
16	Sample 2	544.4	
24	Sample 1	514.3	489.7
24	Sample 2	465.0	
32	Sample 1	312.8	316.4
32	Sample 2	320.1	
39	Sample 1	243.7	229.4
39	Sample 2	215.1	
50	Sample 1	171.1	171.1
60	Sample 1	141.3	129.4
60	Sample 2	117.4	

Table 2.4: Compression test results of yarn 15

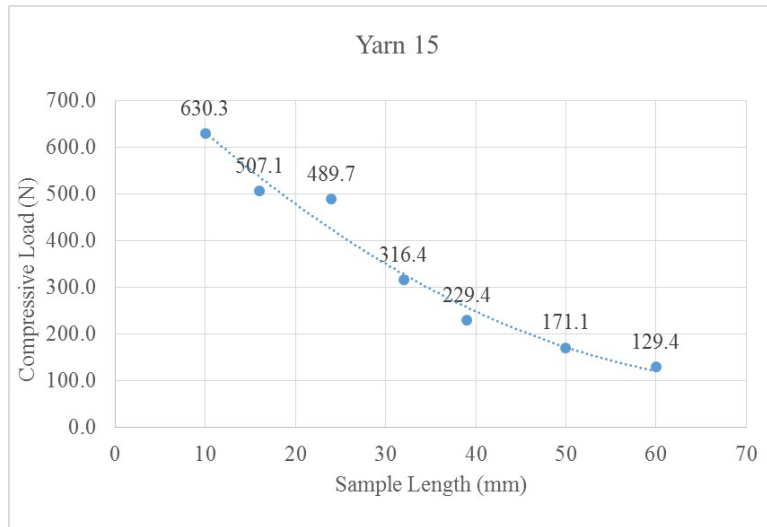

Figure 2.14: Compression load Vs. length plot of yarn 15



Figure 2.15: 60mm yarn 15 sample under compression

2.6.3 Yarn 16

Yarn 16 is one of the three yarns with a total amount 96k CF towpreg, the other two being Yarn 18 and Yarn 20. Figure 2.16 shows the jacket architecture and cross section of the yarn magnified under microscope. As shown in Table 2.5 the jacket of the yarn contained nylon helicals and CF axials.

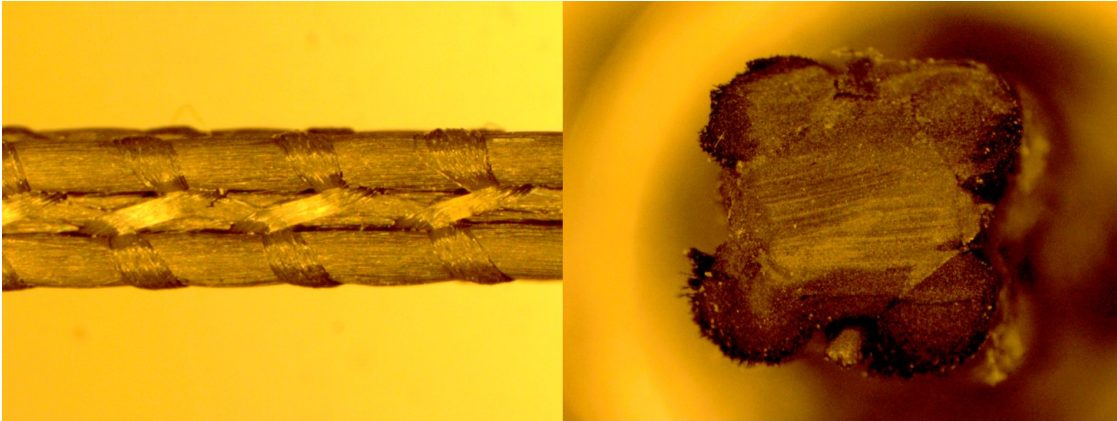

Figure 2.16: Images of yarn 16 under microscope

<i>Core</i>	4 x 12K TCR TowPreg
<i>Jacket</i>	
Axials	4 x 12K TCR TowPreg
CW	4 x 330 den textured nylon
CCW	4 x 330 den textured nylon
Architecture	True Triaxial
Machine	32 Carrier
Geometry	
Cross Section	Square
	2.7mm side
Linear density	8.658gm/m

Table 2.5: Properties of yarn 16

From Tables 2.2 and 2.4 it can be said that Yarn 16 is performing better than Yarn 6 at each different length. Since Yarn 6 and Yarn 16 both have same amount of CF at the core, the CF in the jacket can be stated as reason for the difference in performance. From this it can be said that the CF in the jacket is contributing towards the load bearing capacity of yarns. Figure 2.17 shows the plot between compressive load and sample length of the yarn.

Sample Length (mm)	Sample No	Compressive Load (N)	Average Compressive Load (N)
20	Sample 1	3598.7	3236.4
20	Sample 2	2874.1	
30	Sample 1	2502.3	2165.7
30	Sample 2	1829.2	
38	Sample 1	1851.7	1857.6
38	Sample 2	1863.5	
50	Sample 1	1324.0	1279.5
50	Sample 2	1235.1	
59	Sample 1	969.7	1137.2
59	Sample 2	1304.6	

Table 2.6: Compression test results of yarn 16

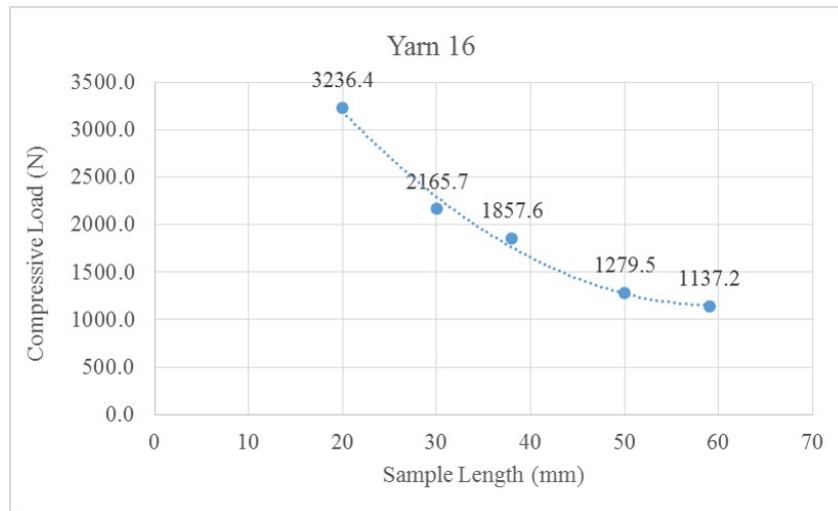

Figure 2.17: Compression load Vs. length plot of yarn 16

2.6.4 Yarn 17

Figure 2.18 shows the jacket architecture and cross section of yarn 17 under microscope. This yarn has four 12k CF axials in the jacket along with 96k CF towpreg in the core. This yarn has the highest amount of CF among all yarns compared in this chapter. Table 2.7 shows the remaining details of construction of the yarn.

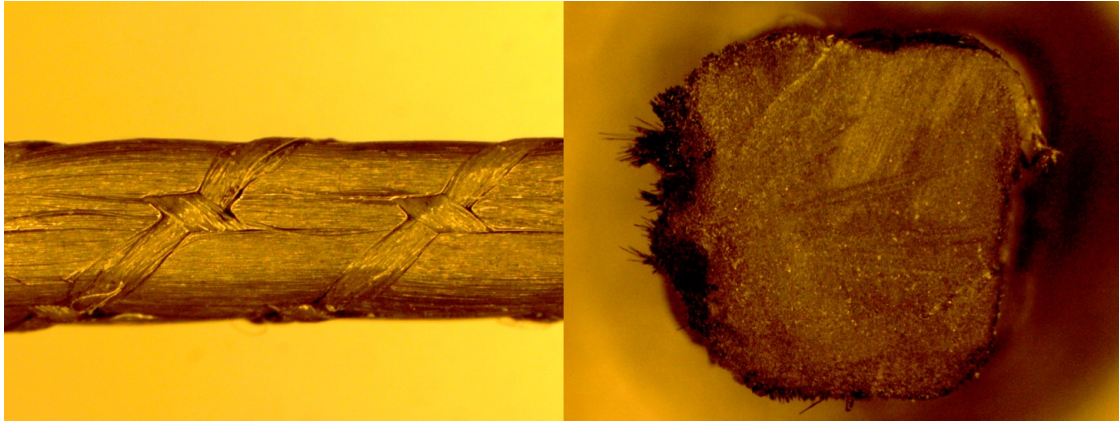

Figure 2.18: Images of yarn 17 under microscope

Core	8 x 12K TCR TowPreg
Jacket	
Axials	4 x 12K TCR TowPreg
CW	4 x 330 den textured nylon
CCW	4 x 330 den textured nylon
Architecture	True Triaxial
Machine	32 Carrier
Geometry	
Cross Section	Square
	3.15mm side
Linear density	12.354gm/m

Table 2.7: Properties of yarn 17

Samples of lengths between 20 and 77 mm were prepared and tested under compression. While samples of length 52mm or shorter failed by crushing, the samples longer than 61mm were observed to be buckling. Table 2.8 and Figure 2.19 show the failure loads of yarn at different lengths.

Sample Length (mm)	Sample No	Compressive Load (N)	Average Compressive Load (N)
20	Sample 1	6081.5	5514.4
20	Sample 2	4947.3	
33	Sample 1	4115.0	4162.9
33	Sample 2	4210.8	
40	Sample 1	4852.0	4287.8
40	Sample 2	3723.6	
52	Sample 1	2853.4	3133.9
52	Sample 2	3414.4	
61	Sample 1	1867.4	1867.4
77	Sample 1	1540.9	1567.6
77	Sample 2	1594.3	

Table 2.8: Compression test results of yarn 17

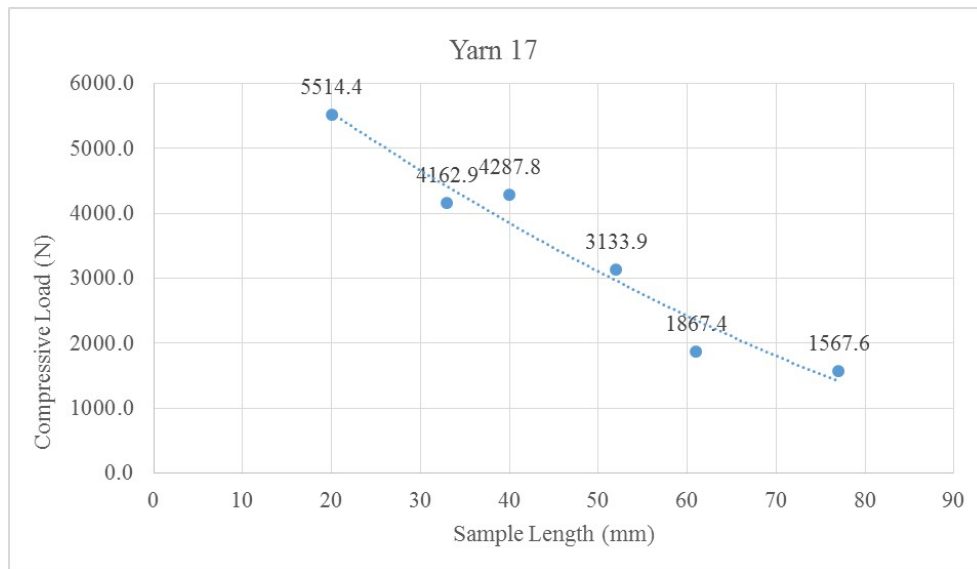

Figure 2.19: Compression load Vs. length plot of yarn 17

2.6.5 Yarn 18

Yarn 18, as shown in Table 2.9, has same jacket as yarn 6 but a different amount of CF in the core. Figure 2.20 shows the jacket architecture and cross section of the yarn observed under a microscope. Like other yarns studied in this chapter which have 4 CF axials in the jacket, yarn 18 also had cross section similar to a square.

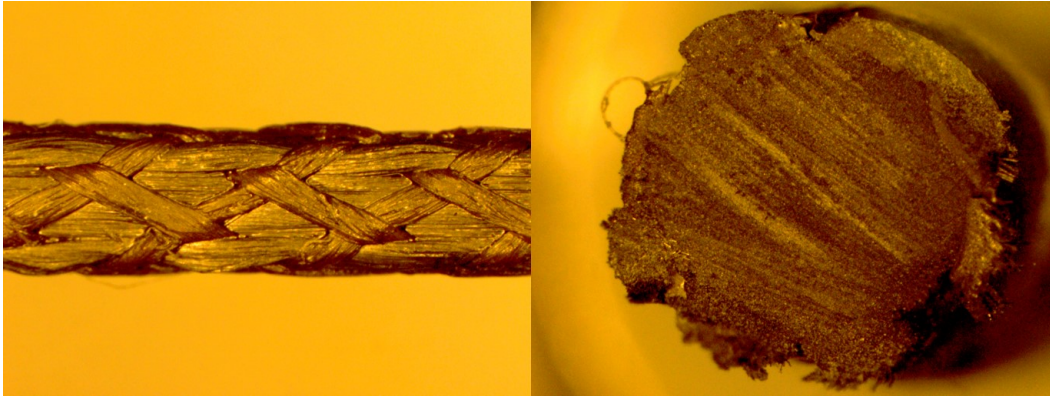

Figure 2.20: Images of yarn 18 under microscope

<i>Core</i>	7x12k TowPreg
<i>Jacket</i>	
Axials	4 x 3K Prepreg
CW	4 x 500 den textured nylon
CCW	4 x 500 den textured nylon
Architecture	True Triaxial
Machine	32 Carrier
Geometry	
Cross Section	Square
	2.7mm side
Linear density	8.665gm/m

Table 2.9: Properties of yarn 18

Table 2.10 shows the failure loads of yarn 18 at different lengths. It was observed that the yarn performed similar to yarn 16 under compression. Figure 2.21 shows the yarn failure at different lengths. The samples of length 41mm or longer were observed to buckle under compression.

Sample Length (mm)	Sample No	Compressive Load (N)	Average Compressive Load (N)
21	Sample 1	3776	3321.6
21	Sample 2	2867.1	
31	Sample 1	2720.3	2395.4
31	Sample 2	2070.5	
41	Sample 1	1385.9	1318.7
41	Sample 2	1251.5	
51	Sample 1	1477.4	1268.8
51	Sample 2	1060.2	
61	Sample 1	835	837
61	Sample 2	839	

Table 2.10: Compression test results of yarn 18

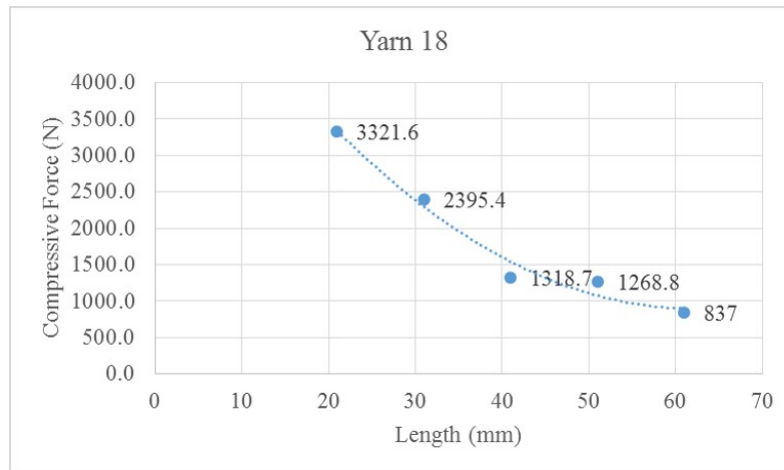

Figure 2.21: Compression load Vs. length plot of yarn 18

2.6.6 Yarn 20

Yarn 20, as shown in Table 2.11 has 96k CF at the core and a jacket made of 1000 denier nylons. Figure 2.22 shows the jacket architecture and cross section of yarn observed under a microscope.

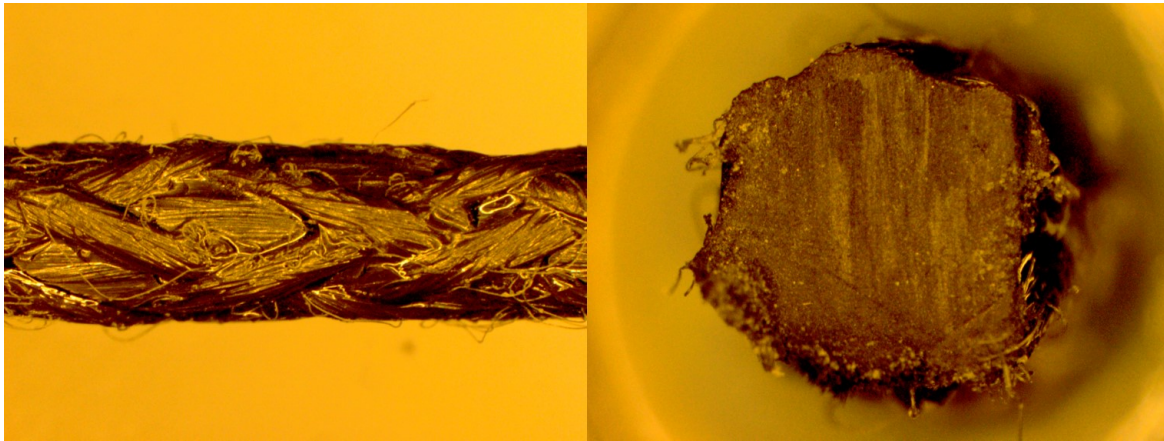

Figure 2.22: Images of yarn 20 under microscope

<i>Core</i>	8x12k TowPreg
<i>Jacket</i>	
Axials	None
CW	4x1000 den textured nylon
CCW	4x1000 den textured nylon
Architecture	Biaxial
Machine	NA
Geometry	
Cross Section	Circular
	3.1mm dia
Linear density	9.678gm/m

Table 2.11: Properties of yarn 20

Samples of lengths between 11 and 58mm were tested under compression and the results are presented in Table 2.12. The samples 52mm or long were observed to fail by buckling.

Sample Length (mm)	Sample No	Compressive Load (N)	Average Compressive Load (N)
11	Sample 1	3848.5	3848.5
19	Sample 1	3101.6	2997.1
19	Sample 2	2892.5	
30	Sample 1	2562.2	2562.2
38	Sample 1	1725.4	1618.9
38	Sample 2	1512.4	
52	Sample 1	1460.7	1376.6
52	Sample 2	1292.5	
58	Sample 1	1326.7	1351.9
58	Sample 2	1377.1	

Table 2.12: Compression test results of yarn 20

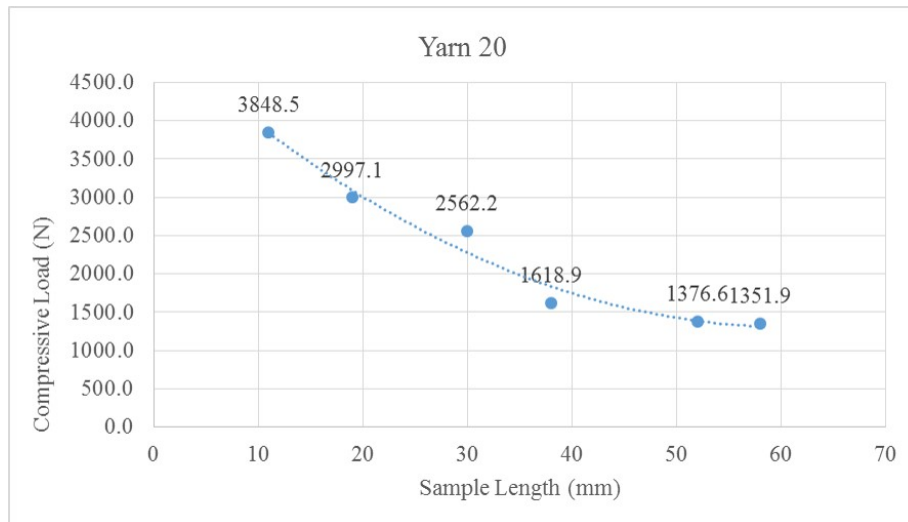

Figure 2.23: Compression load Vs. length plot of yarn 20

2.7 Yarn efficiency and results comparison

Hybrid yarns with different cores (24k, 48k, 84k and 96k carbon fiber towpreg) and different braided jackets (Nylon, polypropelene and carbon fiber towpreg) were tested under compression and their test results were presented in the previous sections of this chapter. To understand how much of the load bearing capacity of fibers is carried over into the final yarn form, the experimental results of yarn compression tests were compared with T700S towpreg literature values [11] and experimental values of pultruded rods made of T700S [12].

To compare the efficiencies of yarns with respect to literature values a new parameter called ' CEY_l ' is defined. CEY_l is the ratio of experimental value of maximum compressive load of a yarn at a given length to the literature value of compressive load of equal amount of carbon fiber filaments as the yarn has. For example to get the CEY_l of yarn 6 at 11mm, the failure load of yarn 6 at 11mm is compared with theoritical failure load of composite with 60k CF filaments.

$$CEY_l (\text{yarn 6, 11mm}) = \frac{\text{Compressiveloadofyarn6at11mm}}{\text{Compressiveloadofcompositewith60kCFfilaments}}$$

Compressive load of yarn 6 at 11mm is 1986.3N (from Table 2.2). Failure load of composite with 60k CF filaments is calculated from T700S data sheet values [11]. According to data sheet the diameter of a single CF filament is 7 microns and compressive strength of T700S composite (60% fiber volume) is 1470MPa. The following steps explain the method used to calculate the failure load of composite with 60k CF filaments

- Cross sectional area of 60k CF filaments = $60,000 * (\pi * 7\text{microns})^2 = 2.3\text{mm}^2$.
- Cross sectional area of a composite in which 60k CF filaments are resulting in a 60% fiber volume = $2.3\text{mm}^2 * (100\%)/(60\%) = 3.84\text{mm}^2$
- Compressive load the composite expected to take = $1470\text{N}/\text{mm}^2 * 3.84\text{mm}^2 = 5644.8\text{N}$

$$\text{Now } CEY_l (\text{yarn 6, 11mm}) = \frac{1986.3\text{N}}{5644.8\text{N}} = 0.35$$

Similarly yarn 15 which has a total number of 24k CF filaments in it is compared with a composite with 24k CF filaments.

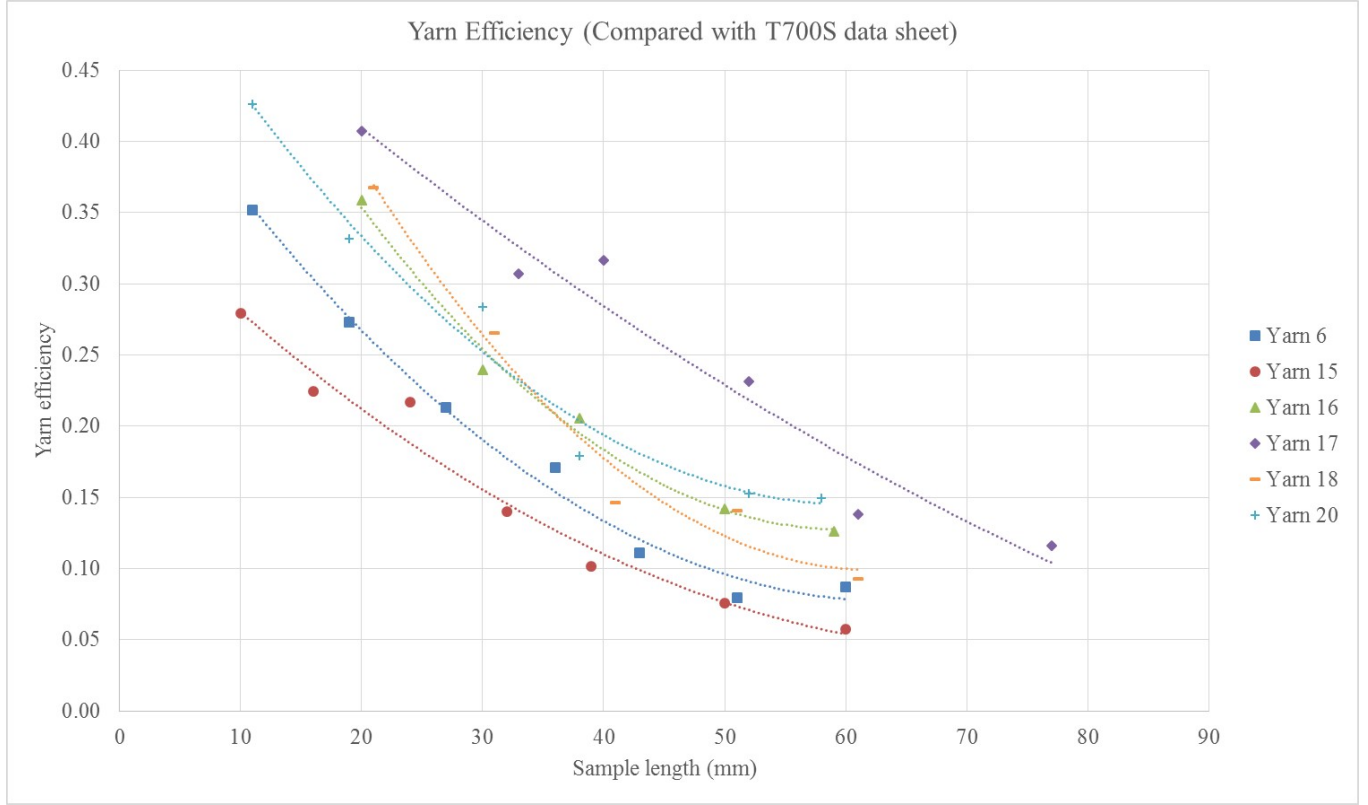

Figure 2.24: Yarn efficiencies (Compared with T700S data sheet)

One more parameter ‘ CEY_p ’ is defined to compare the performance of hybrid yarns with respect to pultruded rods. ‘ CEY_p ’ is the ratio of experimental value of maximum compressive load of a yarn at a given length to the experimental failure load of pultruded yarn. The maximum failure load of a pultruded yarn with 84k CF filaments was experimentally determined to be 3804.9N by a researcher in Auburn University [12]. The pultruded yarn data was scaled whenever a hybrid yarn with different amount of CF filaments was compared with it. For example, yarn 6 efficiency at 11mm is calculated by comparing its failure load with the compressive load of pultruded yarn scaled down to 60k CF filaments, which is 2717.8N.

$$CEY_p (\text{yarn 6, 11mm}) = \frac{\text{Compressiveloadofyarn6at11mm}}{\text{Equivalentcompressiveloadpultrudedrod}}$$

$$CEY_p (\text{yarn 6, 11mm}) = \frac{1986.3N}{2717.8N} = 0.73$$

From Figures 2.24, 2.25 and 2.26 it can be observed that the compressive load bearing capacity of the yarns is decreasing as they are becoming longer, the same trend can be observed with yarn efficiencies. As the total amount of carbon fiber used in the yarn increased,

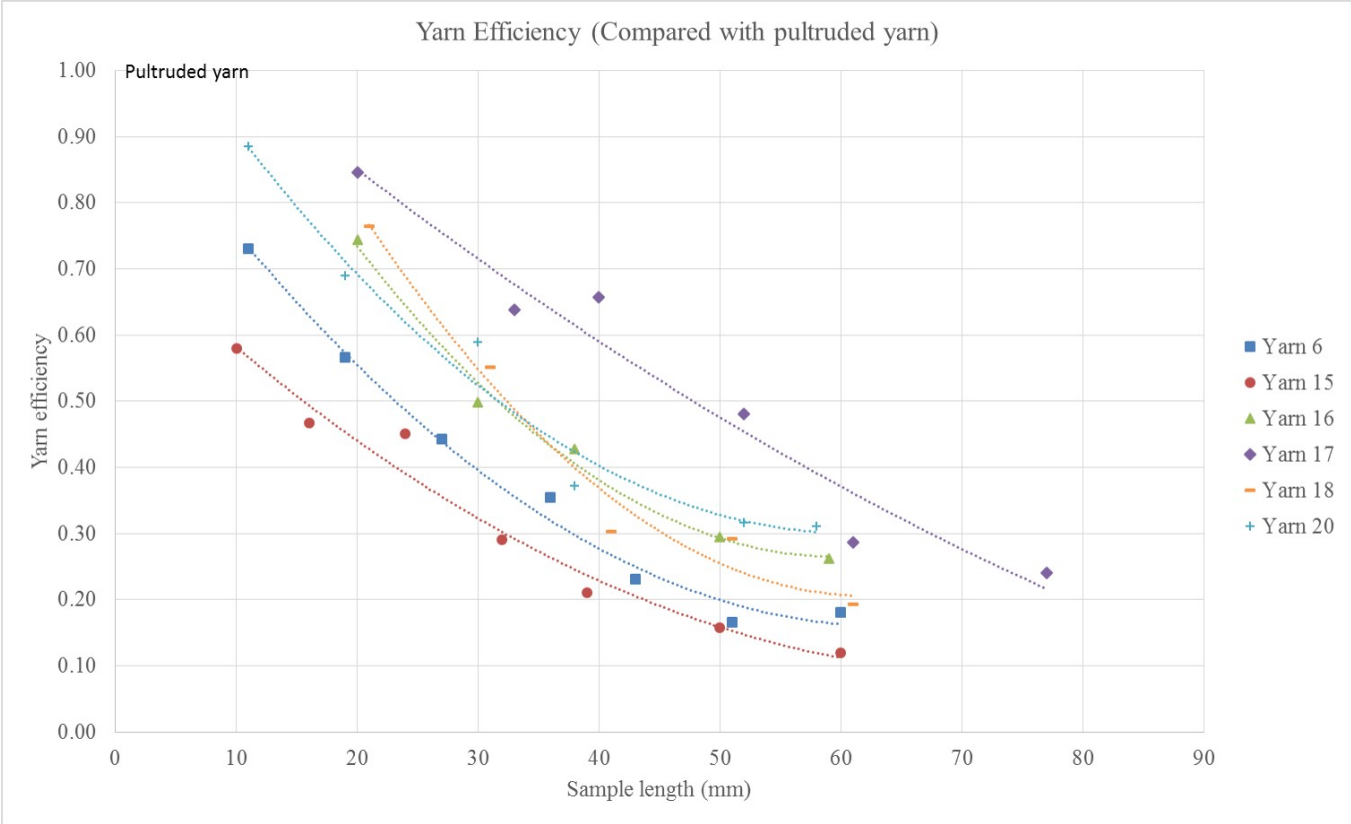

Figure 2.25: Yarn efficiencies (Compared with pultruded yarn)

the maximum compressive load the yarn can withstand has also increased. Yarns 16, 18 and 20, which have same amount of total carbon fiber in them but different amounts in the core and jacket, have shown similar load bearing capabilities. Yarn 18, which has 84k CF at the core and 12k in the jacket, performed a little better than Yarn 16, which has 48k CF at the core and 48k CF in the jacket. From these comparisons it can be said that the CF in the jacket is also contributing towards the load bearing capacity of yarns but not as much as the CF in the core. The crimp in the jacket CF yarns can be stated as reason for this behaviour. Yarn 20, which has 96k CF in the core and none in the jacket, did not perform as good as Yarns 16 and 18. A tight jacket with higher denier nylons appears to be causing crimp in the core CF filaments of Yarn 20 which has a negative effect on its strength.

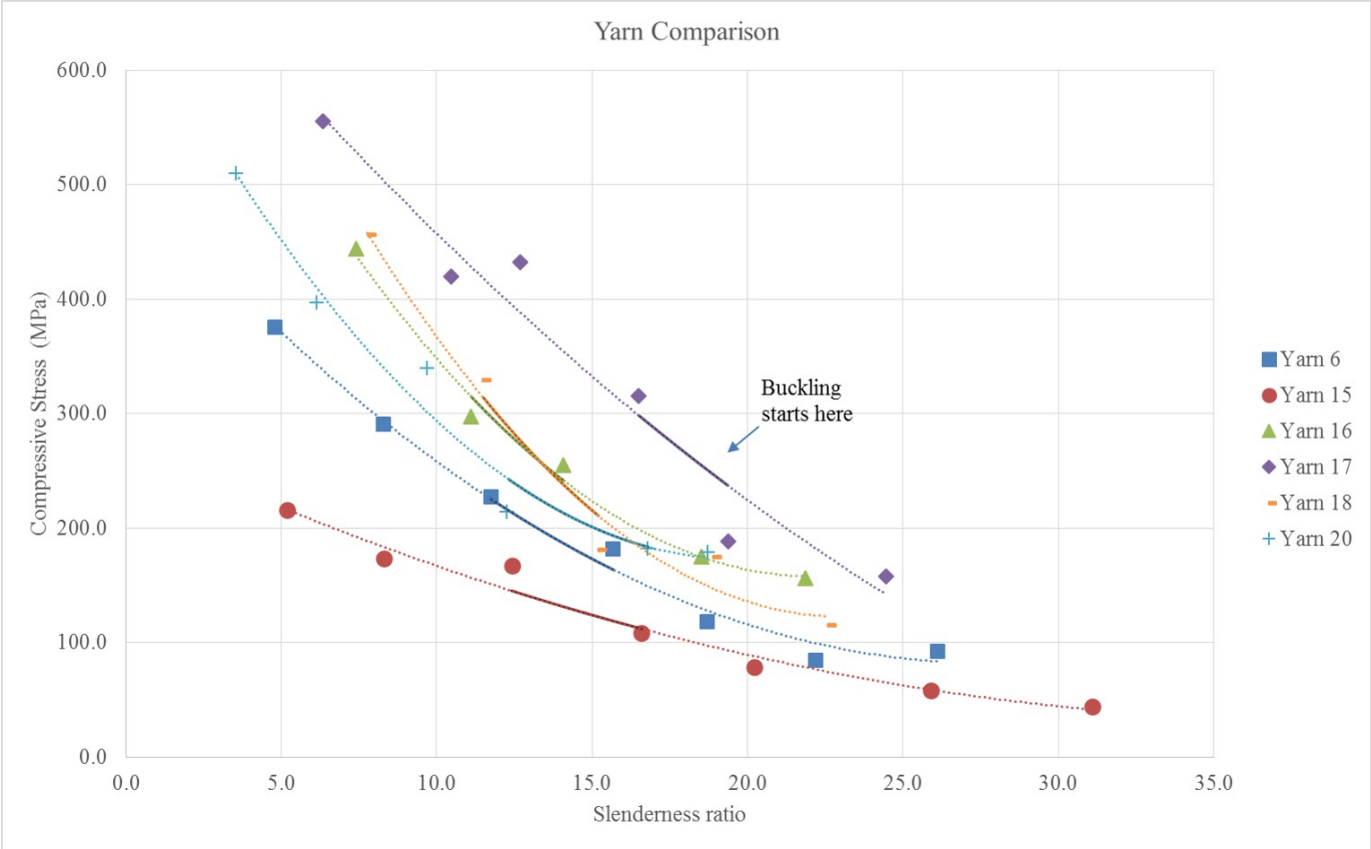

Figure 2.26: Yarn comparison

All the tested yarns have diameters between 1.9-3.2mm and were observed to be buckling over the lengths 32-61mm. Their critical slenderness ratios were observed to be in the range 14.1-19.4, see Figure 2.26. The compressive stress Vs. slenderness ratio curves did not show any variation between crushing and buckling zones of the yarn.

Chapter 3

Development and Testing of O-ACS

3.1 Introduction to O-ACS

Open Architecture Composite Structures, in short called O-ACS, are tubular braids produced by braiding of composite yarns on a maypole braiding machine and subsequent curing of the epoxy resin. The braid consists of either two or three system of yarns alternatively passing over and under each other. One system of yarns moves helically clockwise with respect to the mandrel axis while the other moves helically counter clockwise. In addition to the braiding yarns a system of longitudinal yarns may be introduced into braid. The longitudinal yarns are held in place by the braiding yarns. The longitudinal or axial yarns are not mandatory for the formation of braid, but are introduced for dimensional stability as well as improved compressive and tensile modulus and strength of the braid.

O-ACS with only two systems of yarns running in the helical direction are referred as Biaxials, Figure 3.1, and O-ACS which have axials along with the helicals are referred as Triaxials. A conventional/regular triaxial braid is formed by introducing axial yarns into a conventional biaxial braid. In this technique the helical yarns interlace with each other and the axials pass through the joints where helical yarns meet each other as shown in the Figure 3.2. The researchers at Auburn University developed a new braiding technique to make new type of triaxials. In this technique the oppositely rotating helicals yarns interlace with axial yarns but not with each other as shown in Figure 3.3. The product formed is called a true triaxial braid. If the axial yarns are pulled out from a true triaxial braid, there will not be any interlacing between the two helical yarn systems.



Figure 3.1: A biaxial structure

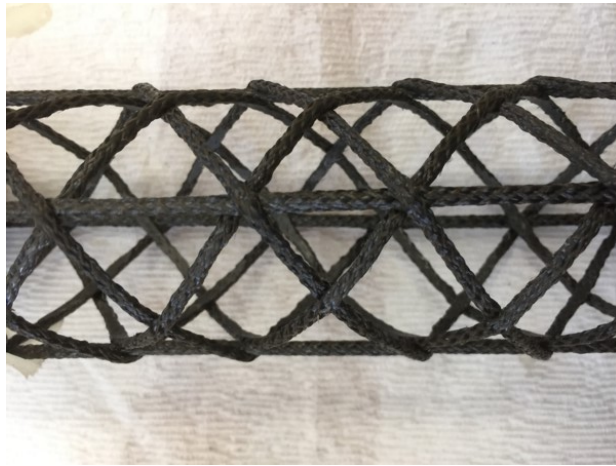

Figure 3.2: A conventional triaxial structure



Figure 3.3: A true triaxial structure

The development and testing of O-ACS aimed at taking higher compressive loads is discussed in this chapter. As with any other structures, the compressive strength of O-ACS depends on how they are made. O-ACS can be made in different sizes, forms and also as seen in the figures before they can be made to have different architectures. The parameters which can be varied while manufacturing O-ACS are

- Axials: Number of axials and size of axials
- Helicals: Number of helicals and size of helicals
- Mandrel: Shape of mandrel and size of mandrel
- Braid angle: Openness of the structure can be changed by changing the braid angle
- Architecture: A true triaxial braid or a conventional triaxial braid

Axial yarns or axials, which run along the length of the structure, are primary load bearing components of O-ACS under compression. So only triaxial structures, which have axial yarns along with helicals, are studied under compression and biaxials are omitted. Different types of triaxial structures were manufactured varying the number and size of axials, braid angle and architecture. As helical yarns do not directly contribute to the compressive strength of the structure the discussion on them is very limited in further sections of the document. They are mainly viewed as components of O-ACS which hold the axial yarns together and prevent them from buckling. All the structures were made on a cylindrical aluminum mandrel of 1.75" diameter. Two or more samples of each type of structure were tested under compression and the results are presented in the next sections of this chapter.

3.2 Manufacturing of O-ACS

The 64 carrier horizontal maypole braiding machine available in Auburn University's Advanced braiding lab is used to manufacture most of the triaxials discussed in this chapter. Of the 64 carriers the machine has, 32 move in the clockwise (CW) direction and the other 32 move in the counter clockwise (CCW) direction. Only few of these carriers are used while manufacturing triaxials depending on the number of helical yarns a triaxial needs to have. For example, if a regular biaxial with 4 CW and 4 CCW helicals needs to be made, 4 of the 32 carriers which move in the respective direction have to be selected to load the yarn bobbins on them. To select the right carriers it is essential to understand the process of braiding, types of braids and the capabilities of a braiding machine.

3.3 Types of Braids

The common way of defining the method of interlacing of a braid is to define the intersection repeat of a yarn [5]. If a yarn continuously passes over two yarns and then under two yarns of the opposite system, it is called a 2/2 braid.

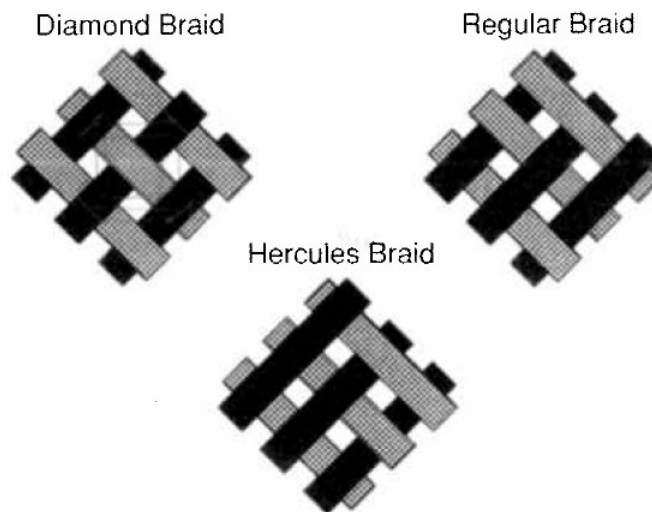

Figure 3.4: Types of braids

The three most common braiding patterns are, Figure 3.4 :

- Diamond braid : a 1/1 intersection repeat
- Regular braid (Plain braid): a 2/2 intersection repeat
- Hercules braid : a 3/3 intersection repeat

The 64 carrier braider is designed to produce a regular braid as shown in the Figure 3.5 when all its carriers are loaded

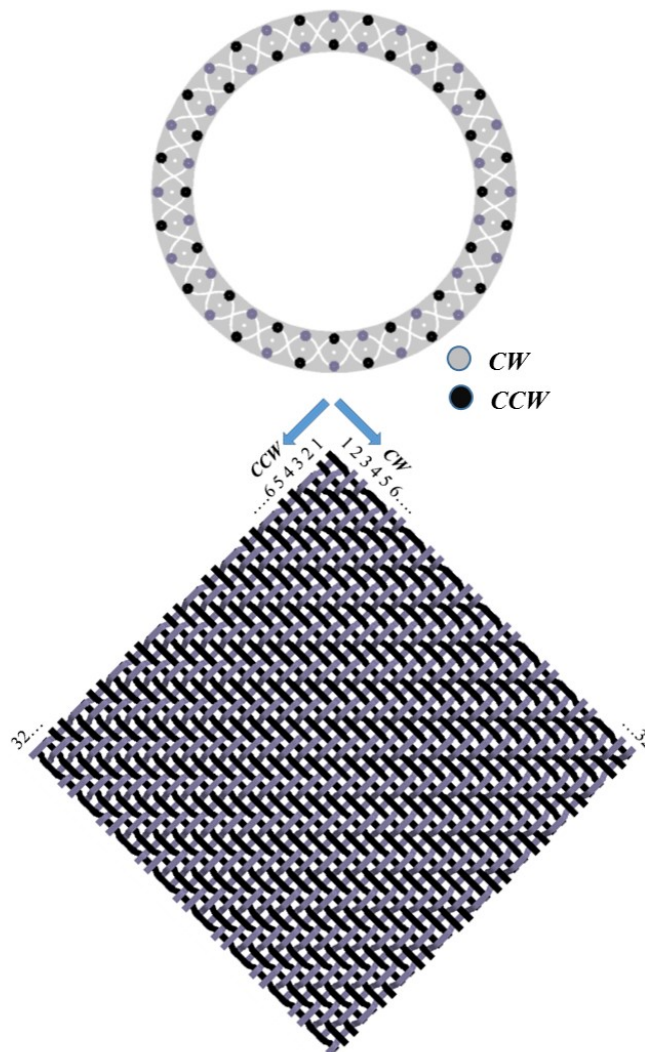

Figure 3.5: The plain braid produced by the 64 carrier machine when all its carriers are loaded

Even though the machine is designed to produce a plain braid, it is possible to generate a diamond braid by choosing the carriers which result in a 1/1 intersection repeat. Figure 3.6 shows the carriers selected to to make 4 CW x 4CCW braid.

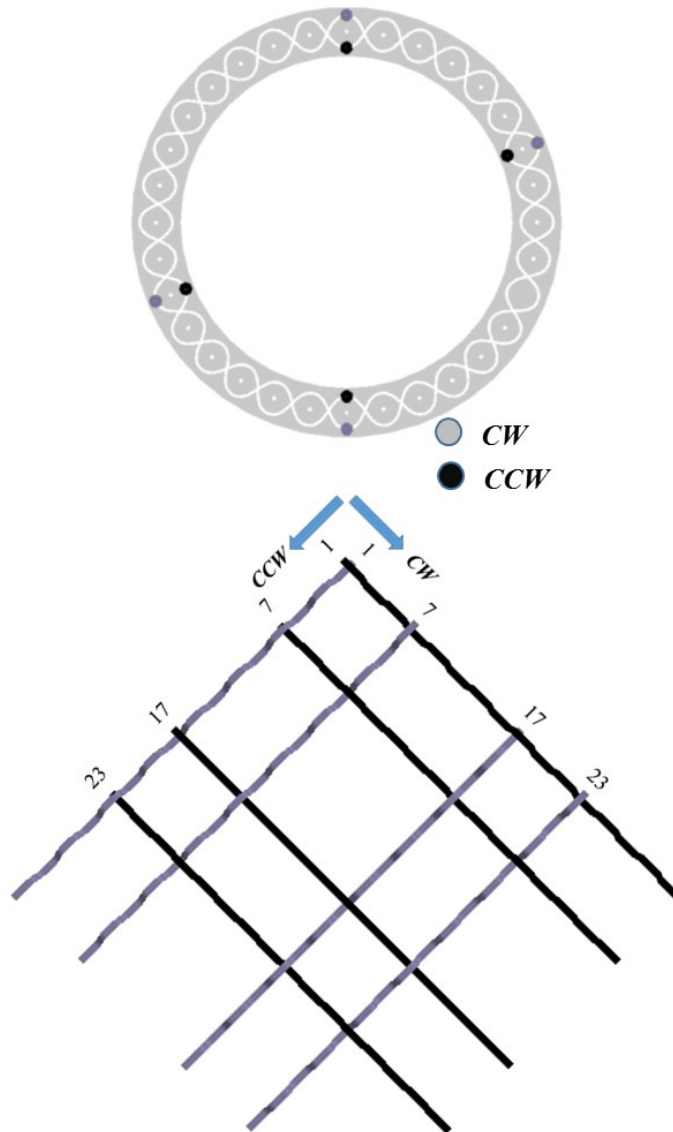

Figure 3.6: Carriers used to make a 4 CW x 4 CCW braid

After the carriers are chosen bobbins loaded with yarn are placed on them. A tubular biaxial braid can be formed, as shown in Figure 3.7 by braiding those yarns on a cylindrical mandrel.



Figure 3.7: A 4 CW x 4 CCW biaxial braid on a circular mandrel

A 4x4x4 conventional/regular triaxial can be formed by introducing axial yarns so that they pass through the joints formed by helical yarns. A 4x4x4 true triaxial structure can be produced choosing helical yarns in such a way that they don't interlace and then introducing axials into them. The braid formed on the mandrel is then cured in the oven at 270°F for four hours as recommended by the towpreg manufacturer and the mandrel is pulled off the structure once it is cured.

3.4 Sample Preparation

Researchers who worked on O-ACS before have developed a technique to hold the samples for testing using pipe nipples [9]. The same technique was followed to prepare the samples for compressive testing and is described in the paragraph below.

The samples were potted with epoxy in 2 inch pipe nipples. The epoxy used for potting was 635 Thin Epoxy Resin by US Composites along with a 3:1 epoxy hardener. Alignment of the specimen axis with the axis of the pipe nipples in which it is potted is extremely important. The specimen was held with these pipe nipples screwed to couplers at each end. The couplers were then strapped to a rectangular rod with a V-groove in it, Fig 3.8, for alignment and then filled with resin one side at a time. A sheet of plastic vacuum-bagging material is used between pipe nipples and couplers to keep the epoxy from leaking.

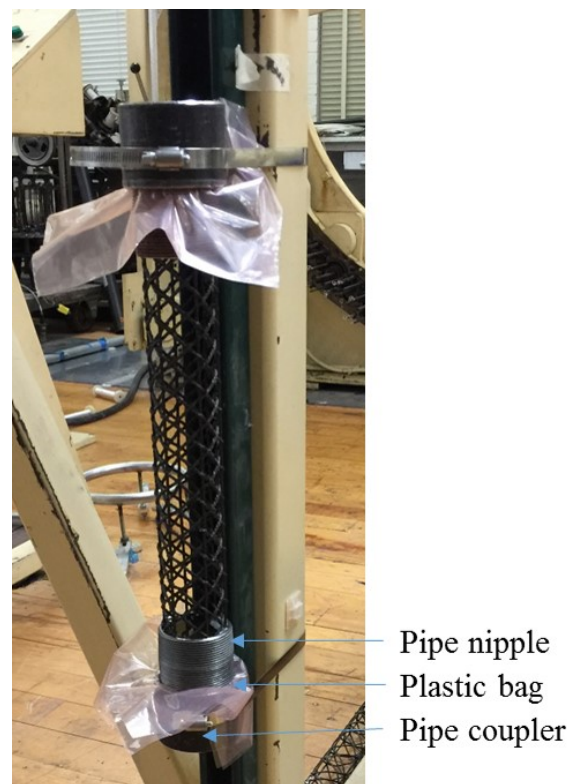

Figure 3.8: Potting of samples

3.5 Test Set Up

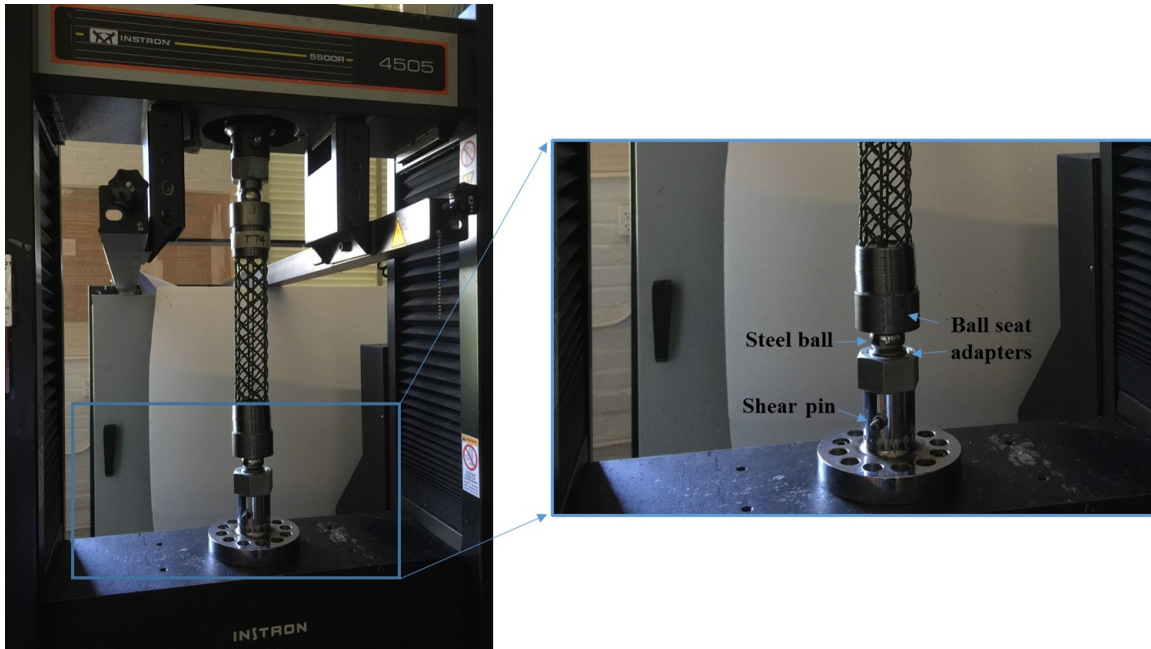

Figure 3.9: Compression test set up for O-ACS

The potted samples were tested under compression using Instron as shown in the Figure 3.9. The pipe nipples in which the samples were potted were screwed to ball seat adapters on both ends. Another set of ball seat adapters were connected to the testing machine using shear pins. Hardened spheres are used between these adapters for better alignment. The crosshead of the Instron machine was moved upwards at a rate of 3mm/min to compress the test sample until failure. The breaking loads of samples were recorded after each test.

Structures of different architectures, span lengths and axials were made and tested. They are discussed in detail in the following sections. A triaxial with 'A' number of axials, 'B' number of clockwise helicals and 'C' number of counter clockwise helicals is represented as A x B x C triaxial in the following sections.

3.6 Experimental results

Researchers who worked on O-ACS before have manufactured and tested 4x4x4 triaxials of different architectures using Yarn 6 [13] [9]. In an effort to understand the effect of increasing the number of axials in O-ACS 6x6x6 triaxials of different architectures were made using Yarn 6 and were tested for their compressive strength.

3.6.1 6x6x6 Triaxials Made Of Yarn 6

Figure 3.10 shows the three types of 6x6x6 triaxials made using Yarn 6. In true triaxials and conventional triaxials the six axials are equally spaced in the structure. The double axials have two axial yarns in each location. There are three such pairs equally spaced in the structure.



Figure 3.10: 6x6x6 Triaxials of different architectures

Table 3.1 shows the geometry of the samples. All the samples were 10” long between the potted ends. A 50 degree braid angle resulted in a 10-12mm span length of the axial yarns.

<i>Axials</i>	6 x Yarn 6
<i>Helicals (CW)</i>	6 x Yarn 6
<i>Helicals (CCW)</i>	6 x Yarn 6
<i>Gauge length</i>	10"
<i>Span Length</i>	10-12 mm
<i>Braid Angle</i>	50deg
<i>Weight</i>	35.2 gm

Table 3.1: Construction of samples

Table 3.2 shows the compression test results of the triaxials tested. The mean and standard deviation were calculated in Microsoft Excel using the functions 'average' and 'stdev.p' respectively.

	<i>True Triaxials</i>	<i>Double Axials</i>	<i>Conventional Triaxials</i>
<i>Sample 1</i>	4116.0	3546.1	3767.9
<i>Sample 2</i>	3854.7	3479.6	3948.3
<i>Sample 3</i>	3560.8	4168.7	3846.7
<i>Mean</i>	3843.9	3731.4	3854.3
<i>Std. Dev.</i>	226.8	310.4	73.9

Table 3.2: Compression test results of 6x6x6 triaxials

Figures 3.11, 3.12 and 3.13 show the graphs of compression tests of true triaxial, double axial and conventional triaxial samples respectively.

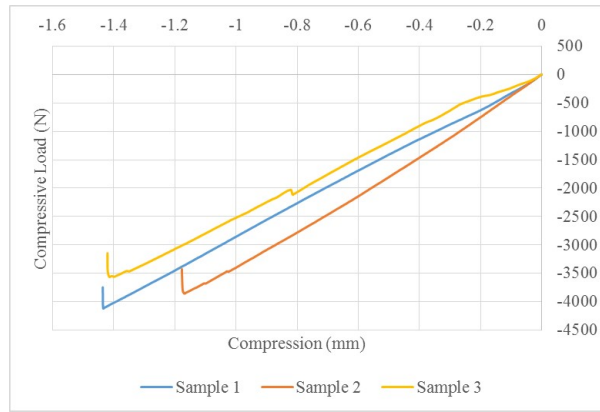

Figure 3.11: Compression load vs Compression plots of 6x6x6 TTs

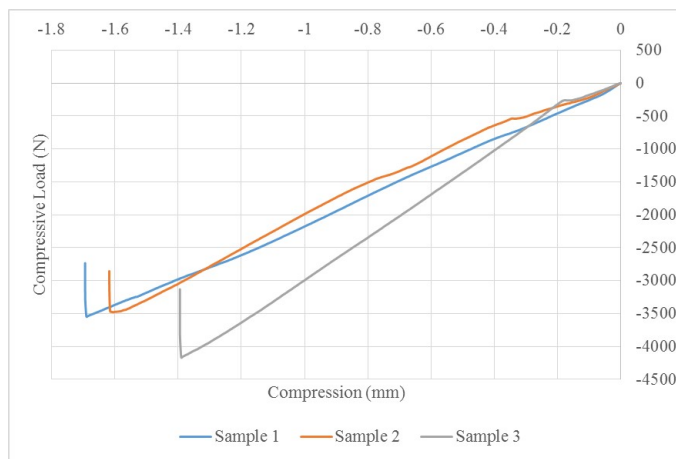

Figure 3.12: Compression load vs Compression plots of 6x6x6 DAs

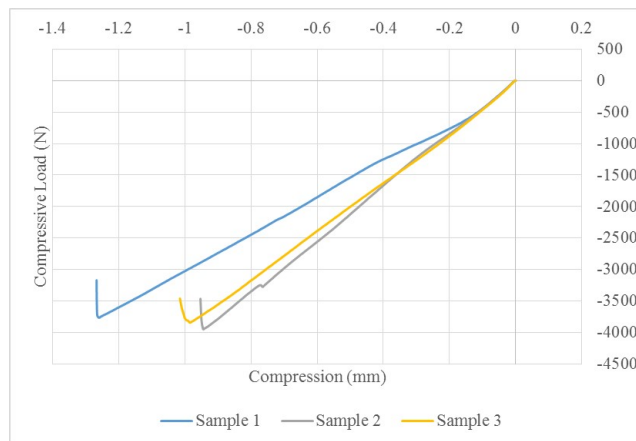

Figure 3.13: Compression load vs Compression plots of 6x6x6 CTs

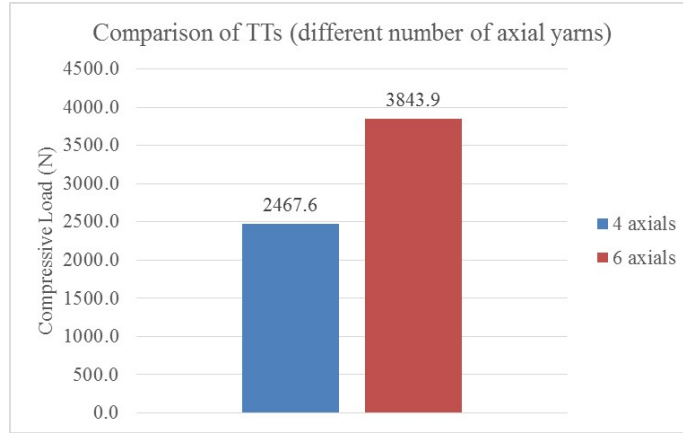

Figure 3.14: Comparison of TTs made of Yarn 6 with different number of axial yarns

As expected the breaking load of true triaxials increased with introduction of more axials (Figure 3.14). But the 6x6x6 CTs, which had crimp in their axials due to misalignment of axial yarns ended up failing at similar loads as 4x4x4 CTs. When 6x6x6 triaxials of different architectures were compared it was observed that they all performed similarly under compression (Figure 3.15).

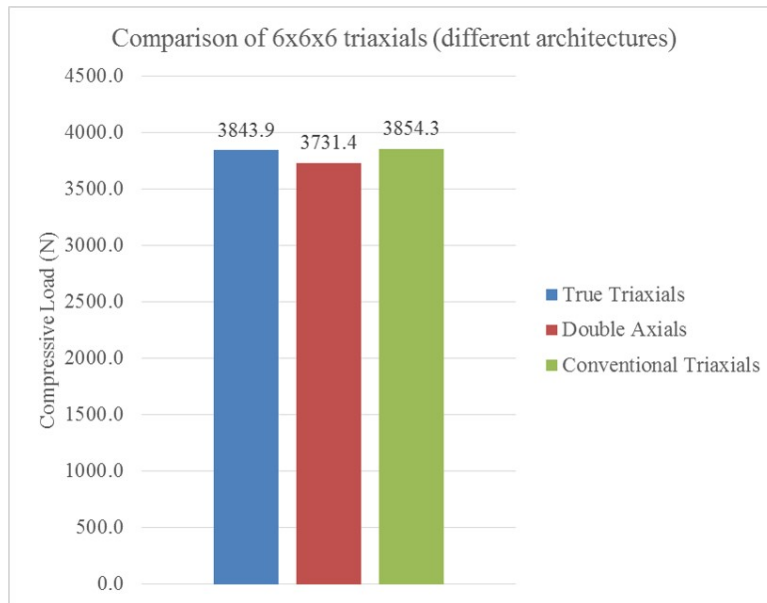

Figure 3.15: 6x6x6 Triaxials of different architectures under Compressive loading

3.6.2 4x4x4 Triaxials made of Yarn 18

In the previous section the effect of increasing the number of axials on compression strength was discussed. In this section the effects of using larger yarns (yarns with more CF in them) and changing span length (or braid angle) are discussed. As shown in Figure 3.16 4x4x4 CTs of different span lengths were manufactured using Yarn 20 in axials.

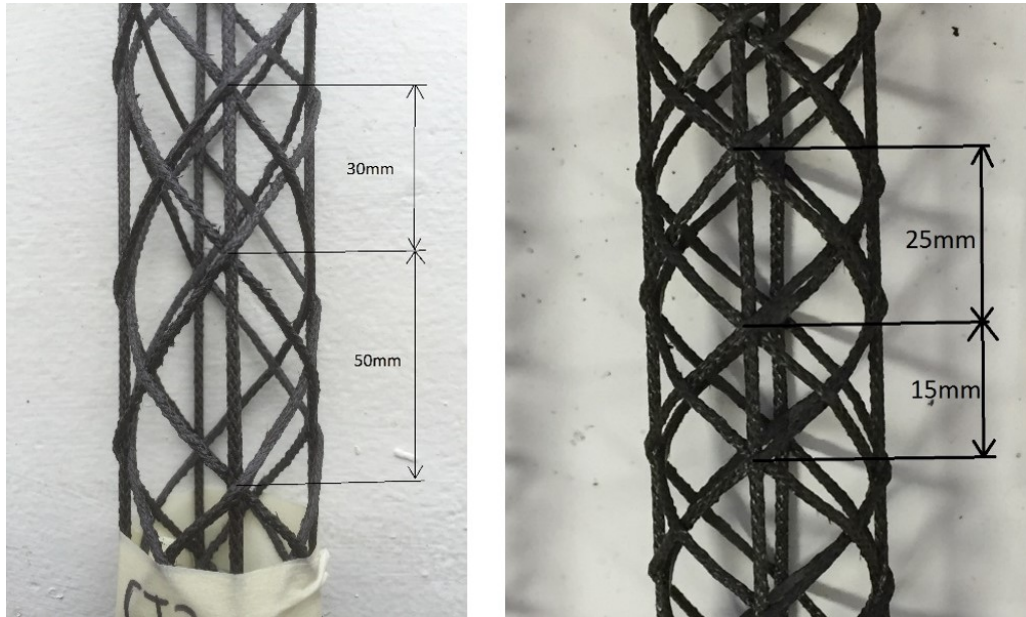

Figure 3.16: 4x4x4 CTs of different span lengths

As shown in Table 3.3 conventional triaxials were made using yarn 18 axials. To keep the weight minimum yarn 6 was used in the helicals.

Architecture	Conventional Triaxials
Axials	4 x Yarn 18
Helicals (CW)	4 x Yarn 6
Helicals (CCW)	4 x Yarn 6
Gauge length	10"
Span Length	30mm & 50mm
Braid Angle	42deg
Weight	24.1

Table 3.3: Geometry and Yarns used in 84k 4x4x4 CTs

Three samples were made and tested under compression. Table 3.4 and Figure 3.17 show the failure loads and graphs of each sample respectively.

Sample No	Compressive Load (N)
Sample 1	4692.2
Sample 2	5120.9
Sample 3	4731.1
Mean	4848.1
Std. Dev.	193.6

Table 3.4: Compression test results of 84k 4x4x4 CTs

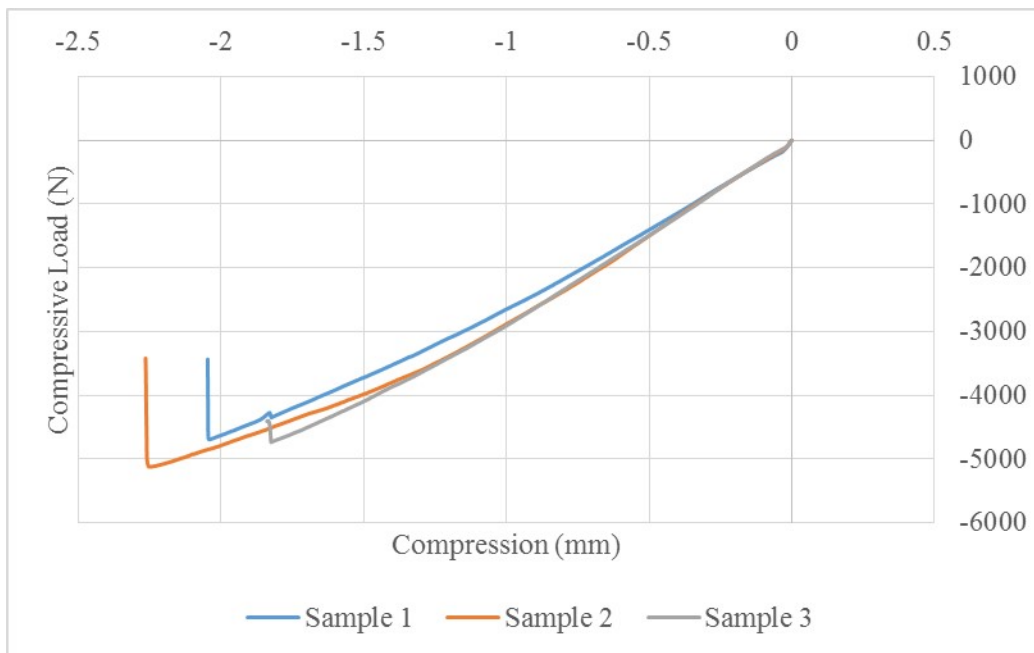

Figure 3.17: Compression load vs Compression plots of 84k 4x4x4 CTs

Another set of similar 4x4x4 conventional triaxials were manufactured but with a shorter span length. Table 3.5 shows the details of construction of structures.

Architecture	Conventional Triaxials
Axials	4 x Yarn 18
Helicals (CW)	4 x Yarn 6
Helicals (CCW)	4 x Yarn 6
Gauge length	10"
Span Length	15mm & 25mm
Braid Angle	60deg
Weight	32gm

Table 3.5: Geometry and Yarns used in 84k 4x4x4 CTs

Only two samples were manufactured and tested. The first sample failed at 8989.6N while the second one failed at 7500.5N. The average compressive load of two samples was calculated to be 8245N. Figure 3.18 shows the test plots of both samples.

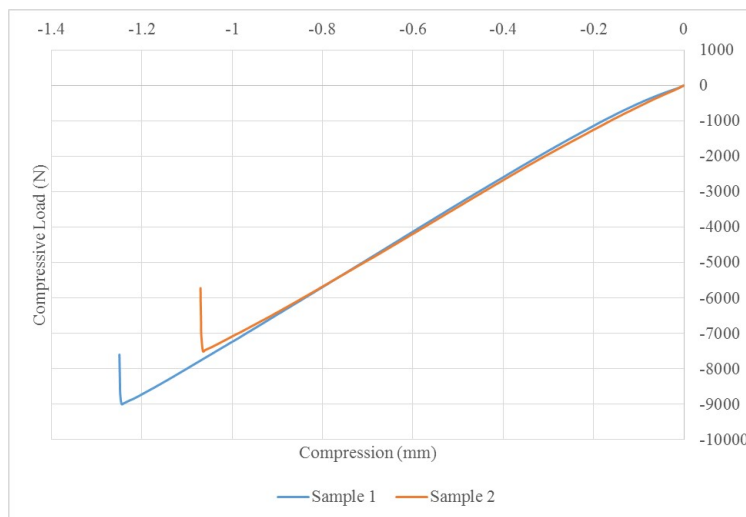

Figure 3.18: Compression load vs Compression plots of 84k 4x4x4 CTs

When the structures with same span length but different axial yarns were compared the structures with larger axial yarns were found to do better than the structures with smaller axial yarns (Figure 3.19).

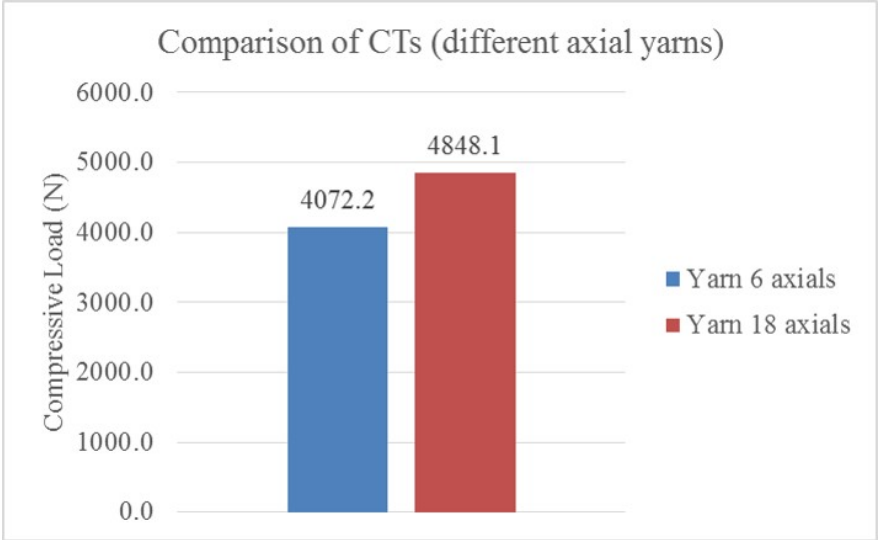

Figure 3.19: Comparison of 4x4x4 CTs with different axial yarns

When the braid angle of structures made using Yarn 18 was increased to decrease the span length their load bearing capacity was remarkably increased (Figure 3.20).

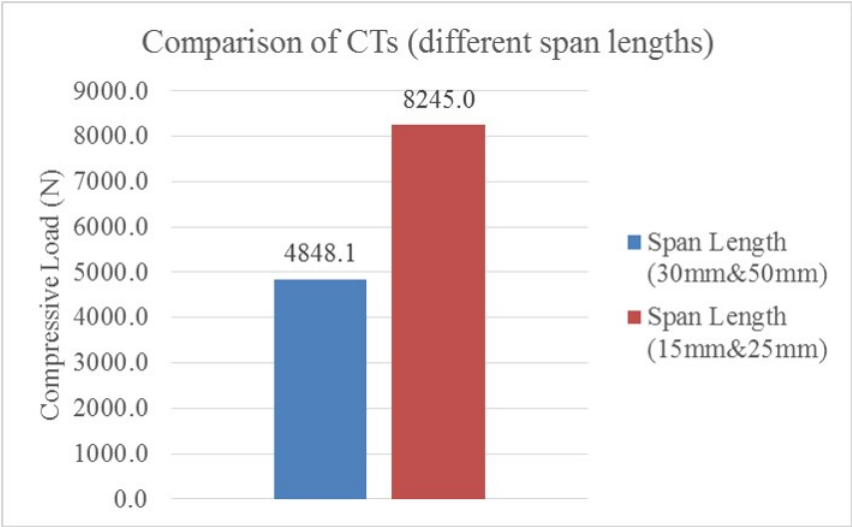

Figure 3.20: Comparison of 4x4x4 CTs with different span lengths

3.7 Failure of Structures

When an axial compressive load is applied at the ends of the structure, the axial yarns of the structure bear all the load. In all the experiments discussed in the previous sections of this chapter the structures failed by the failure of axial yarns, an example is shown in Figure 3.21.



Figure 3.21: A broken axial yarn after compression test of structure

It was observed that the straightness of axial yarns is of paramount importance while making the structures. Any crimp or twist in the axial yarns reduces the performance of the structures drastically.

3.8 Efficiency of structures

A new parameter 'Efficiency of structure' is defined to understand how much of the strength of yarns used to make the structure is carried over into the structure strength. For example a 4x4x4 conventional triaxial made using Yarn 18 in axials and of span length 50mm is compared with four times the load taken by a 50mm Yarn 18 sample.

Calculations

Maximum compressive load of 50mm, Yarn 18 sample - 1280N

Compressive load a structure with four Yarn 18 axials is expected to take - $4 \times 1280 = 5120\text{N}$

Compressive load from experiments - 4848N

Efficiency of the structure = $4848\text{N} / 5120\text{N} = 94.7\%$

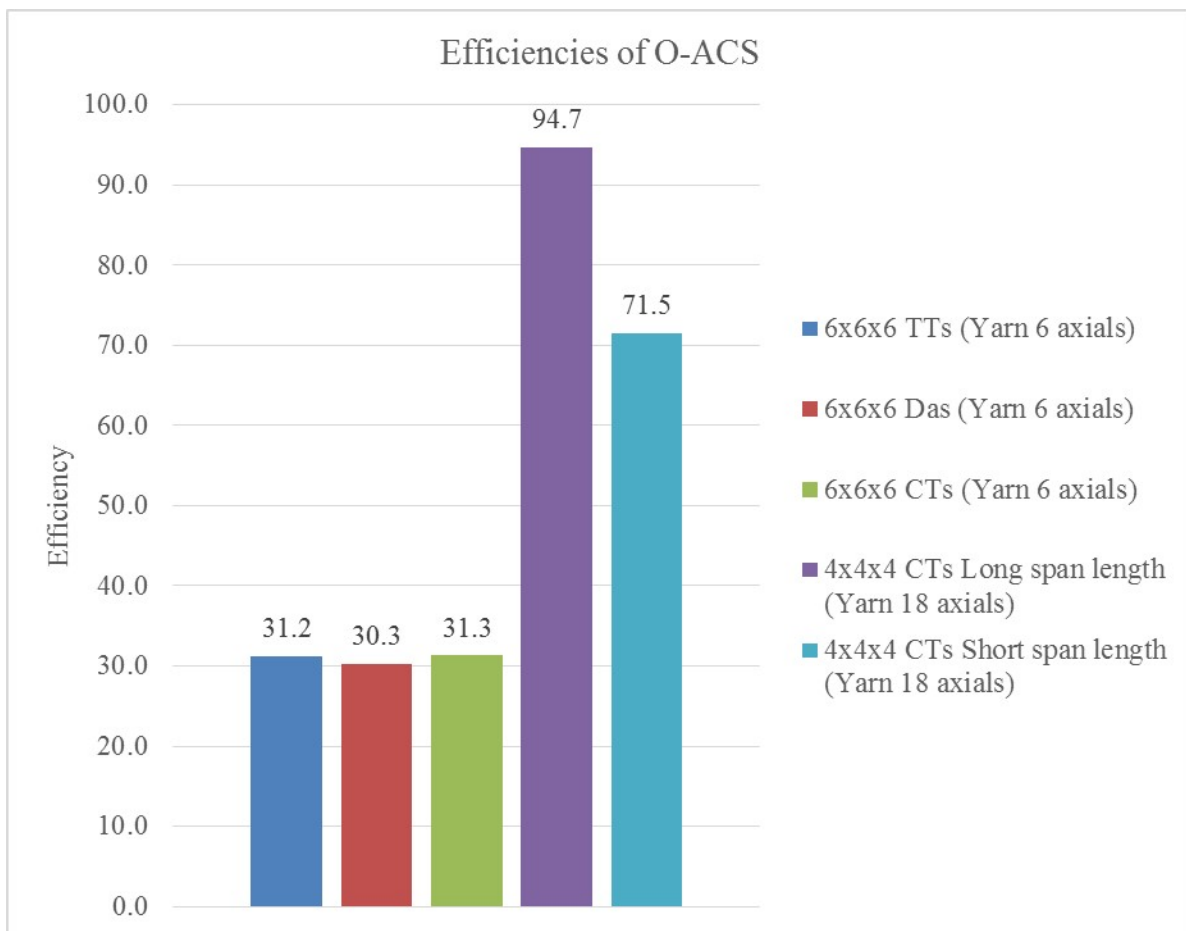

Figure 3.22: Comparison of structural efficiencies of different O-ACS

Figure 3.22 shows the efficiencies of different types of structures discussed in the previous sections of this chapter. 6x6x6 triaxials of all architectures had crimp in their axials and their efficiency was calculated around 30%. The 4x4x4 CTs were made to have straight axials and they exhibited high efficiency under compression.

Chapter 4

Joints

4.1 Introduction

As discussed in the previous chapters O-ACS are formed by braiding composite yarns on a mandrel, and subsequent curing of the epoxy resin. The joints are formed when surface resin on one yarn bonds with surface resin on another yarn during curing. If the composite yarns do not have any resin in the jacket, there will not be any bonding between the yarns and they would slide against each other under the application of load.

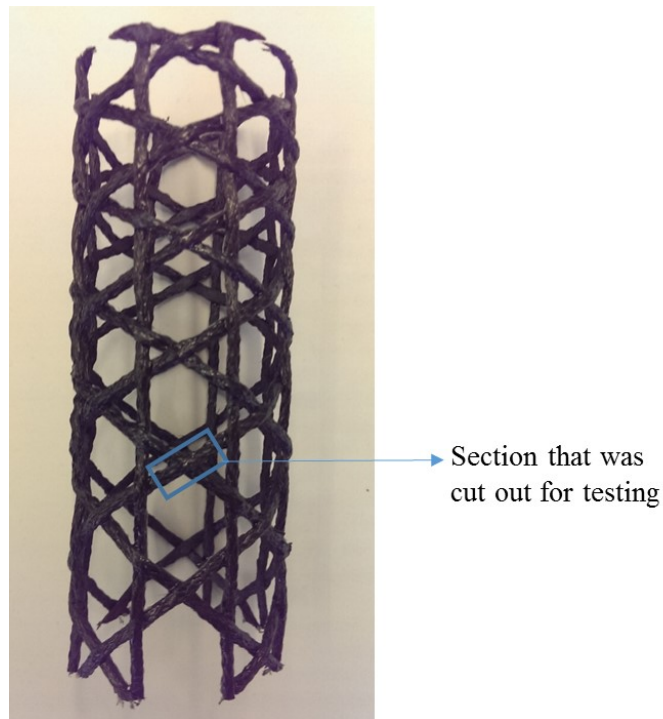

Figure 4.1: A helical-helical joint in a true triaxial open structure

Resin content in the yarns, diameters of the yarns, angle at which the yarns are crossing each other, types of materials used in the jackets of yarns, openness of the jacket braid, amount of carbon fiber towpreg used in the cores of yarns, all have an effect on the bond strength. Understanding the effect of each parameter on the bond strength is daunting unless it is done systematically.

In this chapter the strength of joints formed when two helical yarns meet each other is discussed. Shear tests are done to separate two members of the joints in two different conditions and the results are compared.

A true triaxial structure braided at a 45 degree braid angle, shown in Figure 4.1, is selected for the testing, because a 90 degree angle will be formed when the helicals in the structure meet each other. Cross shaped joint sections as shown the Figure 4.1 are cut out from the structure using a Dremel tool. Figure 4.2 shows the dimensions of a sample used for testing.

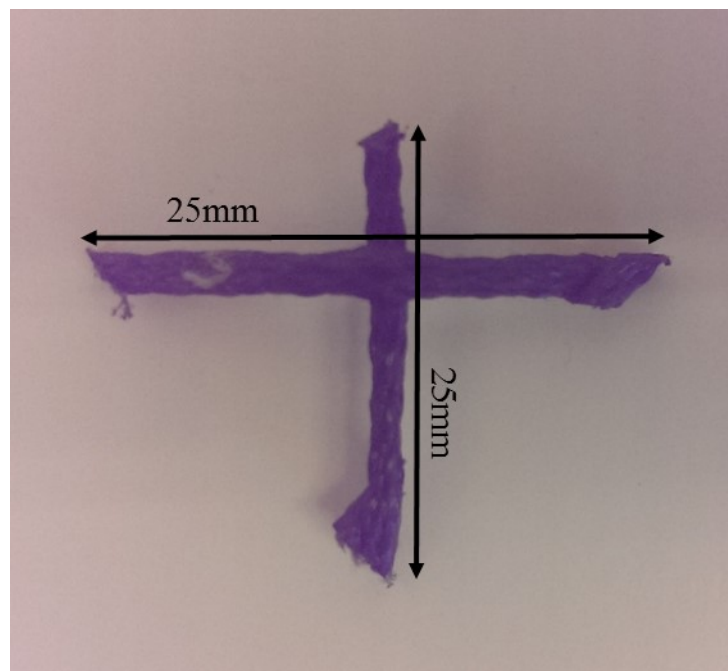

Figure 4.2: A joint cut out from the structure for testing

4.2 Shear Debonding of Joints

Researchers in Auburn University have previously attempted to study the radial separation of joints [10]. For radial separation two wooden blocks, with hooks inserted were used to provide anchorage to the two strings that would hold the joints.

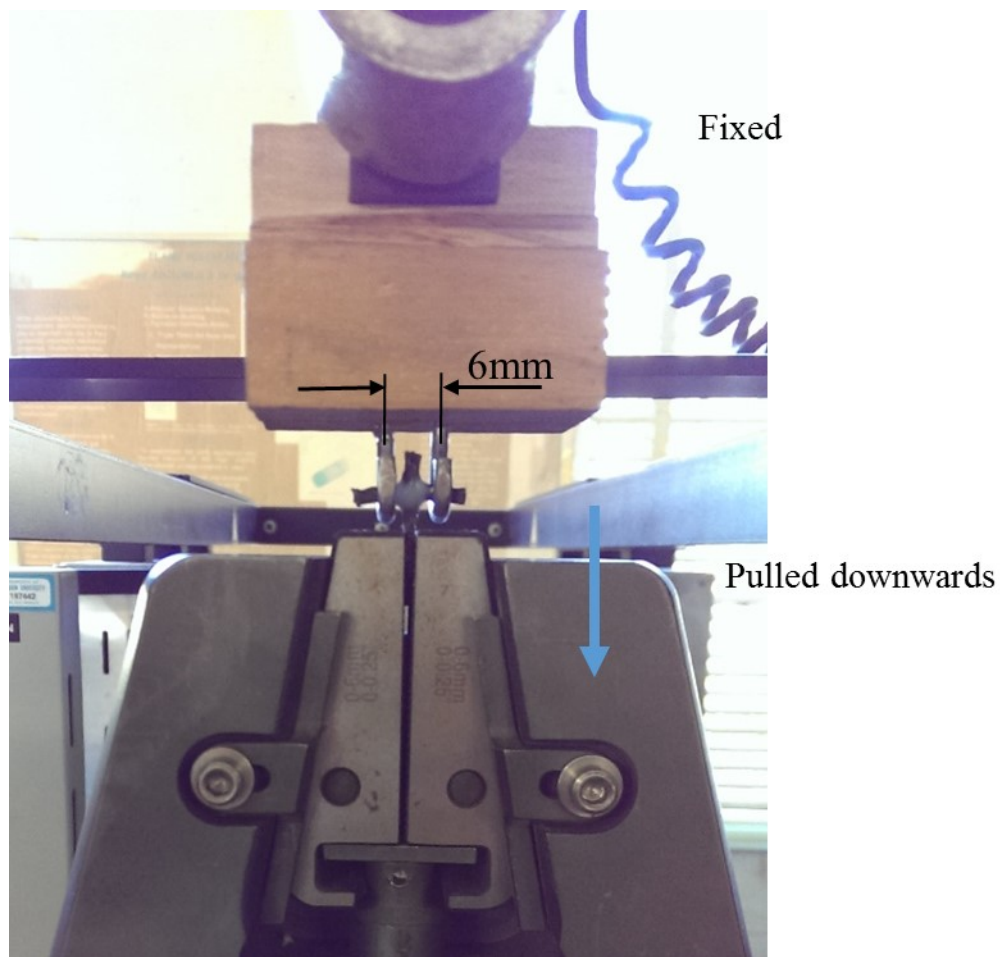

Figure 4.3: Experiment set up for the shear tests

Figure 4.3 shows the experiment set up used to perform the shear tests. For shear tests only one wooden block was used to hold one yarn while the other yarn was pulled using Instron grippers. The tests were stopped when the two yarns separated from each other and the maximum load was recorded.

The first set of experiments were done on the joints without applying any extra glue. In this case the resin in the yarns is the only material which is keeping the yarns together. Shear tests were done on 9 samples and the breaking loads of the joints are presented in the Table 4.1.

Sample No	Max. Load (in N)
1	126.32
2	229.04
3	198.27
4	186.51
5	324.94
6	210.48
7	211.92
8	116.94
9	117.74
Mean	191.35
Standard Deviation	59.42

Table 4.1: Failure of joints without extra glue

And a second set of experiments were done after strengthening the joints by applying 3M DP460 Epoxy adhesive [8]. Figure 4.4 shows a joint after applying the glue.



Figure 4.4: A joint with extra glue applied on it

Sample No	Max. Load (in N)
1	581.78
2	464.52
3	585.18
4	601.75
5	597.24
6	566.73
7	510.67
8	478.51
9	554.38
10	508.01
Mean	544.88
Standard Deviation	47.88

Table 4.2: Failure of joints with extra glue

The breaking loads of the joints after applying glue are presented in Table 4.2. It was observed that the application of small amount of glue markedly improved the breaking load of micro-joints. Figure 4.5 compares the breaking loads of joints before and after applying glue and it can be observed that the extra glue increased the bond strength by almost three times.

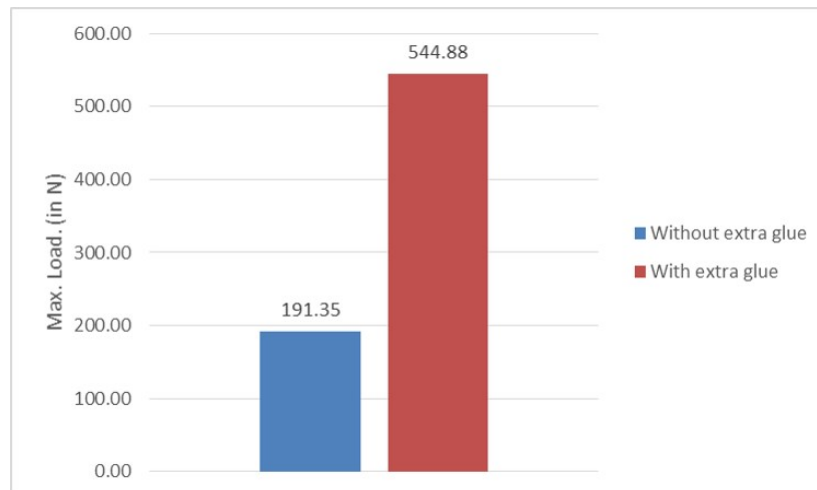

Figure 4.5: Failure of joints: with glue vs without glue

Bibliography

- [1] Eileen De Guire. The discovery of carbon fibers and the practical side of phase diagrams, sep 2012.
- [2] C Soutis. Carbon fiber reinforced plastics in aircraft construction. *Materials Science and Engineering: A*, 412(1):171–176, 2005.
- [3] Ronald F Gibson. *Principles of composite material mechanics*. CRC press, 2011.
- [4] TCR Composites, Ogden, Utah, USA. *Prepreg Resin Selector Guide*, feb 2014.
- [5] AA Head, FK Ko, and CM Pastore. *Handbook of industrial braiding*. Atkins and Pearce, 1989.
- [6] David Branscomb, David Beale, and Royall Broughton. New directions in braiding. *Journal of Engineered Fibers and Fabrics*, *Accepted*, 2012.
- [7] David Branscomb. *Minimal Weight Composites Utilizing Advanced Manufacturing Techniques*. PhD thesis, Auburn University, 2012.
- [8] Scotch-weld epoxy adhesives dp460 off-white, dp460 ns, may 2015.
- [9] Austin Gurley. Design and analysis of optimal braided composite lattice structures. Master’s thesis, Auburn University, 2014.
- [10] Nakul Kothari. Mechanical characterization of the braided composite yarn and bond strength evaluation of the joints of the open-architecture composite structure (o-acs). Master’s thesis, Auburn University, 2014.
- [11] T700s data sheet. <http://www.toraycfa.com/pdfs/T700SDataSheet.pdf>.
- [12] Shivcharan Mysore. Compression testing of pultruded carbon fiber rods. private communication, nov 2015.
- [13] Austin Gurley. Report on the performance of the conventional and triaxial braided lattice. private communication, nov 2014.

Appendices

Appendix A

Carrier selection on 64 carrier machine

A conventional triaxial structure can be produced by introducing axials in a conventional biaxial structure. Location of axials should be such that they pass through the joints where helical yarns meet. The selection of axial carriers is relatively easy once the selection of braiding carriers is understood. The following set of images describe some of the possible combinations of carriers to make a biaxial braid.

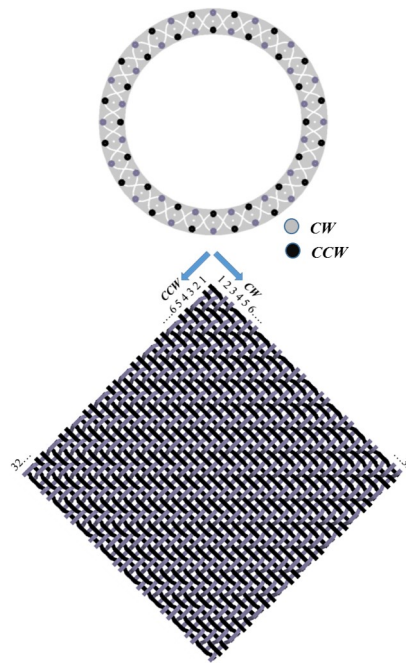

Figure A.1: Plain braid produced by machine when 64 carriers are loaded

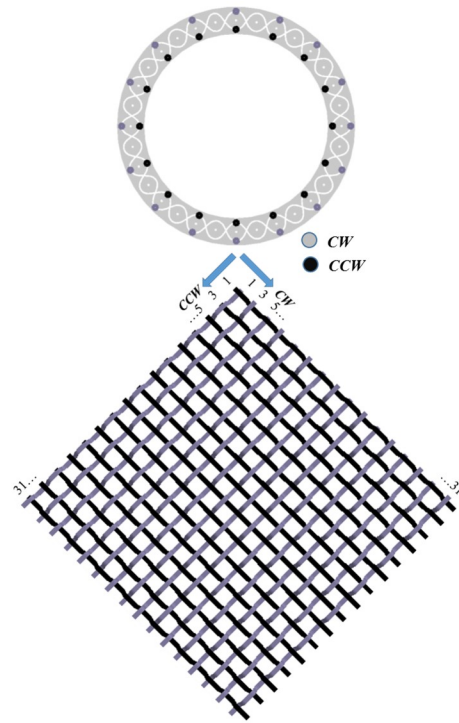

Figure A.2: 16x16 conventional biaxial braid

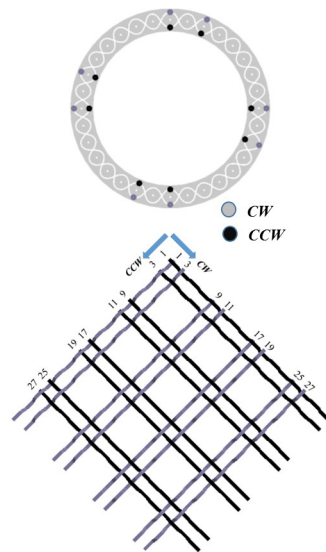

Figure A.3: 8x8 conventional biaxial braid

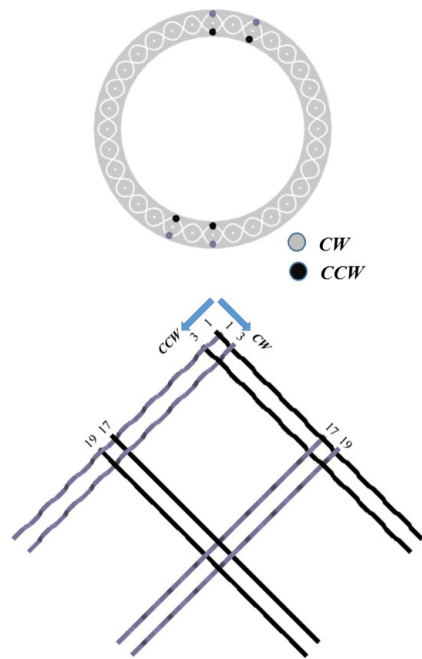

Figure A.4: 4x4 conventional biaxial braid - Type 1

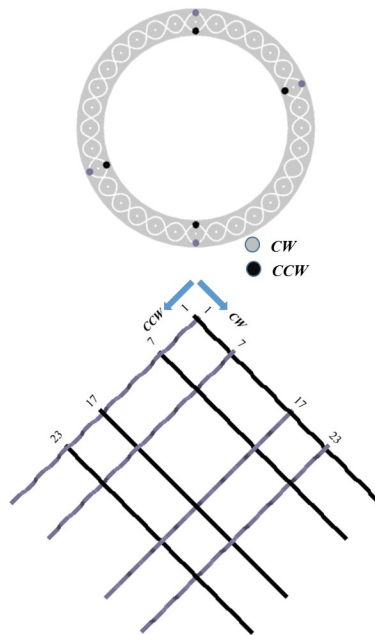

Figure A.5: 4x4 conventional biaxial braid - Type 2