

**Some Studies on the Dynamic Response of Aluminum Cylindrical Shells Using
Acoustic Excitation**

by

Rahul Bapi Reddy

A thesis submitted to the Graduate Faculty of
Auburn University
in partial fulfillment of the
requirements for the Degree of
Master of Science

Auburn, Alabama

May 7th , 2016

Keywords: Cylindrical tube, Natural Frequency, Sound Pressure, Sound Level, Free-Free, Fixed-Free and Fixed-Translation Boundary Conditions, Reverberation Chamber, Speaker

Copyright 2016 by Rahul Bapi Reddy

Approved by

P. K. Raju, Chair, Thomas Walter Professor of Mechanical Engineering

Winfred A. Foster, Jr., Professor of Aerospace Engineering

Dan Marghitu, Professor of Mechanical Engineering

Abstract

An understanding of the vibration and acoustic properties of cylindrical shells is vital if we are to solve noise problems in a wide range of practical applications, especially those that occur in pipes, ducts, aircraft fuselage and rockets.

The focus of this study was thus to analyze the dynamic response and acoustic properties of cylindrical shells with different types of end cap configurations namely Flat Ends and Dome Ends. These structures were studied for Free-Free, Fixed-Free and Fixed-Translation boundary conditions. An experimental study was conducted in a reverberation chamber using acoustic excitation and the results compared with those obtained using a numerical model developed using MSC/Nastran and MSC/Patran. The results obtained from the numerical and experimental models were in good agreement, thus validating the numerical model.

Acknowledgments

The author would like to express his gratitude to his major professor and advisor, Dr. P. K. Raju, for his patience, guidance and continuous support throughout the course of the author's research.

I would like to thank Dr. Winfred A. Foster, Jr., for his guidance in different aspects of the research project and also for serving on the advisory committee.

In addition I would like to thank Dr. Dan Marghitu, who served on the advisory committee.

I would like to thank Pramod Rajan, Sai Maharaja Swamidason and Eliza Banu for their valuable contribution in my research.

I would like to thank Dr. Jeffrey C Suhling for his generous initial support in the graduate course and all the professors who taught my academic classes .

The author is grateful to NASA's Marshall Space Flight Center for their sponsorship of this research.

Finally, the author wishes to extend his deepest appreciation to his parents Brahmananda Reddy and Hemalatha, his sister Lekha and his friends, for their constant encouragement and support throughout this endeavor.

Table of Contents

Abstract	ii
Acknowledgments	iii
List of Figures	vii
List of Tables	xix
1 Introduction	1
1.1 Schematic Test Setup for a Cylindrical Shell	1
1.1.1 Bruel & Kjaer Pulse Multi-Analyzer System Type 3560C	2
1.1.2 Bruel & Kjaer Pulse Lab Shop Software with Reflex- 19.0 Version	2
1.1.3 FFT Analyzer	3
1.1.4 CPB Analyzer	4
1.1.5 System Calibration	4
1.1.6 Coherence	4
1.1.7 Stereo Amplifier (Total Output 600 W)	5
1.1.8 4" High Power Speaker	5
1.1.9 Microphones	6
1.1.10 Piezoelectric Accelerometer	7
1.1.11 HP Compaq 8200 Elite Windows based System	8
1.1.12 Reverberation Room	8
1.1.13 CAD Drawings of Cylindrical Tube	9
1.1.14 Setup Conditions	11
2 Dynamic Response of Aluminum Tubes using Acoustic Excitation	13
2.1 Aluminum Tube with Flat End Cap Configuration	13
2.1.1 Free-Free Boundary Condition	13

2.1.2	Fixed-Free Boundary Condition	24
2.1.3	Fixed-Translation Boundary Condition	34
2.2	Aluminum Tube with Dome End Cap Configuration	44
2.2.1	Free-Free Boundary Condition	44
2.2.2	Fixed-Free Boundary Condition	54
2.2.3	Fixed-Translation Boundary Condition	64
3	Comparison of Graphs between End Cap Configurations and Boundary Conditions	74
3.1	Comparison of Graphs between Dome and Flat End Cap Configurations Under the Free-Free Condition:	74
3.2	Comparison of graphs between Dome and Flat End Cap Configurations Under the Fixed-Free Condition:	81
3.3	Comparison of graphs between Dome and Flat End Cap Configurations Under the Fixed-Translation Condition:	87
3.4	Comparison of graphs between Free-Free, Fixed-Free and Fixed-Translation Condition for Dome End Cap Configuration:	93
3.5	Comparison of graphs between Free-Free, Fixed-Free and Fixed-Translation Condition for Flat End Cap Configuration:	99
4	Numerical Model Analysis using MSC Nastran/Patran Software	105
4.1	Aluminum Tube with Flat End Cap Configuration	105
4.1.1	Free-Free Boundary Condition	105
4.1.2	Fixed-Free Boundary Condition	115
4.1.3	Fixed-Translation Boundary Condition	123
4.2	Aluminum Tube with Dome End Cap Configuration	131
4.2.1	Free-Free Boundary Condition	131
4.2.2	Fixed-Free Boundary Condition	141
4.2.3	Fixed-Translation Boundary Condition	149
5	Conclusion	157

Bibliography 161

List of Figures

1.1	Schematic Test Setup	2
1.2	Bruel&Kjaer Pulse Multi-Analyzer System Type 3560C	3
1.3	Pyramid Stereo Amplifier	5
1.4	Matrix 4" High Power Speaker	6
1.5	Bruel & Kjaer Microphone Type 4188L-001	7
1.6	ENDEVCO Piezoelectric Accelerometer	8
1.7	Outside view of the reverberation chamber	9
1.8	Cylindrical Tube with Dome Ends	10
1.9	Dome End with Speaker Setup	10
1.10	Cylindrical Tube with Flat Ends	11
1.11	Flat End with Speaker Setup	11
1.12	Pictures of the jack stand with the fixture to hold the tube	12
2.1	Free-Free Experimental Setup	14
2.2	FWD End Setup	14
2.3	Internal loudspeaker Setup (AFT End)	15

2.4	Mic AFT (dB) Vs Frequency (Hz) (Aluminum Tube with Flat End Caps, Free-Free Condition)	16
2.5	Mic FWD (dB) Vs Frequency (Hz) (Aluminum Tube with Flat End Caps, Free-Free Condition)	17
2.6	Sound Pressure Level (dB) Vs Frequency (Hz) (Aluminum Tube with Flat End Caps, Free-Free Condition)	18
2.7	Mic AFT (Pa) Vs Frequency (Hz) (Aluminum Tube with Flat End Caps, Free-Free Condition)	19
2.8	Mic FWD (Pa) Vs Frequency (Hz) (Aluminum Tube with Flat End Caps, Free-Free Condition)	20
2.9	Sound Pressure (Pa) Vs Frequency (Hz) (Aluminum Tube with Flat End Caps, Free-Free Condition)	21
2.10	Acceleration (m/s^2) Vs Frequency (Hz) (Aluminum Tube with Flat End Caps, Free-Free Condition)	22
2.11	Fixed-Free Experimental Setup	24
2.12	Mic AFT (dB) Vs Frequency (Hz) (Aluminum Tube with Flat End Caps, Fixed-Free Condition)	26
2.13	Mic FWD (dB) Vs Frequency (Hz) (Aluminum Tube with Flat End Caps, Fixed-Free Condition)	27
2.14	Sound Pressure Level (dB) Vs Frequency (Hz) (Aluminum Tube with Flat End Caps, Fixed-Free Condition)	28

2.15	Mic AFT (Pa) Vs Frequency (Hz) (Aluminum Tube with Flat End Caps, Fixed-Free Condition)	29
2.16	Mic FWD (Pa) Vs Frequency (Hz) (Aluminum Tube with Flat End Caps, Fixed-Free Condition)	30
2.17	Sound Pressure (Pa) Vs Frequency (Hz) (Aluminum Tube with Flat End Caps, Fixed- Free Condition)	31
2.18	Acceleration (m/s^2) Vs Frequency (Hz) (Aluminum Tube with Flat End Caps, Fixed- Free Condition)	32
2.19	Fixed-Translation Experimental Setup	34
2.20	Mic AFT (dB) Vs Frequency (Hz) (Aluminum Tube with Flat End Caps, Fixed-Translation Condition)	36
2.21	Mic FWD (dB) Vs Frequency (Hz) (Aluminum Tube with Flat End Caps, Fixed-Translation Condition)	37
2.22	Sound Pressure Level (dB) Vs Frequency (Hz) (Aluminum Tube with Flat End Caps, Fixed-Translation Condition)	38
2.23	Mic AFT (Pa) Vs Frequency (Hz) (Aluminum Tube with Flat End Caps, Fixed-Translation Condition)	39
2.24	Mic FWD (Pa) Vs Frequency (Hz) (Aluminum Tube with Flat End Caps, Fixed-Translation Condition)	40
2.25	Sound Pressure (Pa) Vs Frequency (Hz) (Aluminum Tube with Flat End Caps, Fixed-Translation Condition)	41

2.26	Acceleration (m/s^2) Vs Frequency (Hz) (Aluminum Tube with Flat End Caps, Fixed-Translation Condition)	42
2.27	Free-Free Experimental Setup	44
2.28	Mic AFT (dB) Vs Frequency (Hz) (Aluminum Tube with Dome End Caps, Free-Free Condition)	46
2.29	Mic FWD (dB) Vs Frequency (Hz) (Aluminum Tube with Dome End Caps, Free-Free Condition)	47
2.30	Sound Pressure Level (dB) Vs Frequency (Hz) (Aluminum Tube with Dome End Caps, Free-Free Condition)	48
2.31	Mic AFT (Pa) Vs Frequency (Hz) (Aluminum Tube with Dome End Caps, Free-Free Condition)	49
2.32	Mic FWD (Pa) Vs Frequency (Hz) (Aluminum Tube with Dome End Caps, Free-Free Condition)	50
2.33	Sound Pressure (Pa) Vs Frequency (Hz) (Aluminum Tube with Dome End Caps, Free-Free Condition)	51
2.34	Acceleration (m/s^2) Vs Frequency (Hz) (Aluminum Tube with Dome End Caps, Free-Free Condition)	52
2.35	Fixed-Free Experimental Setup	54
2.36	Mic AFT (dB) Vs Frequency (Hz) (Aluminum Tube with Dome End Caps, Fixed-Free Condition)	56
2.37	Mic FWD (dB) Vs Frequency (Hz) (Aluminum Tube with Dome End Caps, Fixed-Free Condition)	57

2.38	Sound Pressure Level (dB) Vs Frequency (Hz) (Aluminum Tube with Dome End Caps, Fixed-Free Condition)	58
2.39	Mic AFT (Pa) Vs Frequency (Hz) (Aluminum Tube with Dome End Caps, Fixed-Free Condition)	59
2.40	Mic FWD (Pa) Vs Frequency (Hz) (Aluminum Tube with Dome End Caps, Fixed-Free Condition)	60
2.41	Sound Pressure (Pa) Vs Frequency (Hz) (Aluminum Tube with Dome End Caps, Fixed- Free Condition)	61
2.42	Acceleration (m/s^2) Vs Frequency (Hz) (Aluminum Tube with Dome End Caps, Fixed- Free Condition)	62
2.43	Fixed-Translation Experimental Setup	64
2.44	Mic AFT (dB) Vs Frequency (Hz) (Aluminum Tube with Dome Ends, Fixed-Translation Condition)	66
2.45	Mic FWD (dB) Vs Frequency (Hz) (Aluminum Tube with Dome Ends, Fixed-Translation Condition)	67
2.46	Sound Pressure Level (dB) Vs Frequency (Hz) (Aluminum Tube with Dome Ends, Fixed-Translation Condition)	68
2.47	Mic AFT (Pa) Vs Frequency (Hz) (Aluminum Tube with Dome Ends, Fixed-Translation Condition)	69
2.48	Mic FWD (Pa) Vs Frequency (Hz) (Aluminum Tube with Dome Ends, Fixed-Translation Condition)	70

2.49	Sound Pressure (Pa) Vs Frequency (Hz) (Aluminum Tube with Dome Ends, Fixed-Translation Condition)	71
2.50	Acceleration (m/s^2) Vs Frequency (Hz) (Aluminum Tube with Dome Ends, Fixed-Translation Condition)	72
3.1	Mic AFT (dB) Vs Frequency (Hz) (Aluminum Tube with Free-Free Condition) (Dome vs Flat)	76
3.2	Mic FWD (dB) Vs Frequency (Hz) (Aluminum Tube with Free-Free Condition) (Dome vs Flat)	77
3.3	Mic AFT (Pa) Vs Frequency (Hz) (Aluminum Tube with Free-Free Condition) (Dome vs Flat)	78
3.4	Mic FWD (Pa) Vs Frequency (Hz) (Aluminum Tube with Free-Free Condition) (Dome vs Flat)	79
3.5	Acceleration (m/s^2) Vs Frequency (Hz) (Aluminum Tube with Free-Free Condition) (Dome vs Flat)	80
3.6	Mic AFT (dB) Vs Frequency (Hz) (Aluminum Tube with Fixed-Free Condition) (Dome vs Flat)	82
3.7	Mic FWD (dB) Vs Frequency (Hz) (Aluminum Tube with Fixed-Free Condition) (Dome vs Flat)	83
3.8	Mic AFT (Pa) Vs Frequency (Hz) (Aluminum Tube with Fixed-Free Condition) (Dome vs Flat)	84
3.9	Mic FWD (Pa) Vs Frequency (Hz) (Aluminum Tube with Fixed-Free Condition) (Dome vs Flat)	85

3.10	Acceleration (m/s^2) Vs Frequency (Hz) (Aluminum Tube with Fixed-Free Condition) (Dome vs Flat)	86
3.11	Mic AFT (dB) Vs Frequency (Hz) (Aluminum Tube with Fixed-Translation Condition) (Dome vs Flat)	88
3.12	Mic FWD (dB) Vs Frequency (Hz) (Aluminum Tube with Fixed-Translation Condition) (Dome vs Flat)	89
3.13	Mic AFT (Pa) Vs Frequency (Hz) (Aluminum Tube with Fixed-Translation Condition) (Dome vs Flat)	90
3.14	Mic FWD (Pa) Vs Frequency (Hz) (Aluminum Tube with Fixed-Translation Condition) (Dome vs Flat)	91
3.15	Acceleration (m/s^2) Vs Frequency (Hz) (Aluminum Tube with Fixed-Translation Condition) (Dome vs Flat)	92
3.16	Mic AFT (dB) Vs Frequency (Hz) (Aluminum Tube with Dome End Cap) (Free-Free Vs Fixed-Free Vs Fixed-Translation)	94
3.17	Mic FWD (dB) Vs Frequency (Hz) (Aluminum Tube with Dome End Cap) (Free-Free Vs Fixed-Free Vs Fixed-Translation)	95
3.18	Mic AFT (Pa) Vs Frequency (Hz) (Aluminum Tube with Dome End Cap) (Free-Free Vs Fixed-Free Vs Fixed-Translation)	96
3.19	Mic FWD (Pa) Vs Frequency (Hz) (Aluminum Tube with Dome End Cap) (Free-Free Vs Fixed-Free Vs Fixed-Translation)	97
3.20	Acceleration (m/s^2) Vs Frequency (Hz) (Aluminum Tube with Dome End Cap) (Free-Free Vs Fixed-Free Vs Fixed-Translation)	98

3.21	Mic AFT (dB) Vs Frequency (Hz) (Aluminum Tube with Flat End Cap) (Free-Free Vs Fixed-Free Vs Fixed-Translation)	100
3.22	Mic FWD (dB) Vs Frequency (Hz) (Aluminum Tube with Flat End Cap) (Free-Free Vs Fixed-Free Vs Fixed-Translation)	101
3.23	Mic AFT (Pa) Vs Frequency (Hz) (Aluminum Tube with Flat End Cap) (Free-Free Vs Fixed-Free Vs Fixed-Translation)	102
3.24	Mic FWD (Pa) Vs Frequency (Hz) (Aluminum Tube with Flat End Cap) (Free-Free Vs Fixed-Free Vs Fixed-Translation)	103
3.25	Acceleration (m/s^2) Vs Frequency (Hz) (Aluminum Tube with Flat End Cap) (Free-Free Vs Fixed-Free Vs Fixed-Translation)	104
4.1	Numerical Analysis Mesh for the Aluminum Tube with Flat End Caps (Free-Free Condition)	106
4.2	Mic AFT (dB) Vs Frequency (Hz) (Aluminum Tube with Flat End Caps, Free-Free Condition)	108
4.3	Mic FWD (dB) Vs Frequency (Hz) (Aluminum Tube with Flat End Caps, Free-Free Condition)	109
4.4	Sound Pressure Level (dB) Vs Frequency (Hz) (Aluminum Tube with Flat End Caps, Free-Free Condition)	110
4.5	Mic AFT (Pa) Vs Frequency (Hz) (Aluminum Tube with Flat End Caps, Free-Free Condition)	111
4.6	Mic FWD (Pa) Vs Frequency (Hz) (Aluminum Tube with Flat End Caps, Free-Free Condition)	112

4.7	Sound Pressure (Pa) Vs Frequency (Hz) (Aluminum Tube with Flat End Caps, Free-Free Condition)	113
4.8	Numerical Analysis Setup of Aluminum Tube with Flat End Caps (Fixed-Free Condition)	115
4.9	Mic AFT (dB) Vs Frequency (Hz) (Aluminum Tube with Flat End Caps, Fixed-Free Condition)	116
4.10	Mic FWD (dB) Vs Frequency (Hz) (Aluminum Tube with Flat End Caps, Fixed-Free Condition)	117
4.11	Sound Pressure Level (dB) Vs Frequency (Hz) (Aluminum Tube with Flat End Caps, Fixed-Free Condition)	118
4.12	Mic AFT (Pa) Vs Frequency (Hz) (Aluminum Tube with Flat End Caps, Fixed-Free Condition)	119
4.13	Mic FWD (Pa) Vs Frequency (Hz) (Aluminum Tube with Flat End Caps, Fixed-Free Condition)	120
4.14	Sound Pressure (Pa) Vs Frequency (Hz) (Aluminum Tube with Flat End Caps, Fixed-Free Condition)	121
4.15	Mesh used for the Numerical Analysis of the Aluminum Tube with Flat End Caps (Fixed- Translation Condition)	123
4.16	Mic AFT (dB) Vs Frequency (Hz) (Aluminum Tube with Flat End Caps, Fixed-Translation Condition)	124
4.17	Mic FWD (dB) Vs Frequency (Hz) (Aluminum Tube with Flat End Caps, Fixed-Translation Condition)	125

4.18 Sound Pressure Level (dB) Vs Frequency (Hz) (Aluminum Tube with Flat End Caps, Fixed-Translation Condition)	126
4.19 Mic AFT (Pa) Vs Frequency (Hz) (Aluminum Tube with Flat End Caps, Fixed-Translation Condition)	127
4.20 Mic FWD (Pa) Vs Frequency (Hz) (Aluminum Tube with Flat End Caps, Fixed-Translation Condition)	128
4.21 Sound Pressure (Pa) Vs Frequency (Hz) (Aluminum Tube with Flat End Caps, Fixed-Translation Condition)	129
4.22 Numerical Analysis Mesh for the Aluminum Tube with Dome End Caps (Free-Free Condition)	132
4.23 Mic AFT (dB) Vs Frequency (Hz) (Aluminum Tube with Dome End Caps, Free-Free Condition)	134
4.24 Mic FWD (dB) Vs Frequency (Hz) (Aluminum Tube with Dome End Caps, Free-Free Condition)	135
4.25 Sound Pressure Level (dB) Vs Frequency (Hz) (Aluminum Tube with Dome End Caps, Free-Free Condition)	136
4.26 Mic AFT (Pa) Vs Frequency (Hz) (Aluminum Tube with Dome End Caps, Free-Free Condition)	137
4.27 Mic FWD (Pa) Vs Frequency (Hz) (Aluminum Tube with Dome End Caps, Free-Free Condition)	138
4.28 Sound Pressure (Pa) Vs Frequency (Hz) (Aluminum Tube with Dome End Caps, Free-Free Condition)	139

4.29 Numerical Analysis Mesh for an Aluminum Tube with Dome End Caps (Fixed-Free Condition)	141
4.30 Mic AFT (dB) Vs Frequency (Hz) (Aluminum Tube with Dome End Caps, Fixed-Free Condition)	142
4.31 Mic FWD (dB) Vs Frequency (Hz) (Aluminum Tube with Dome End Caps, Fixed-Free Condition)	143
4.32 Sound Pressure Level (dB) Vs Frequency (Hz) (Aluminum Tube with Dome End Caps, Fixed-Free Condition)	144
4.33 Mic AFT (Pa) Vs Frequency (Hz) (Aluminum Tube with Dome End Caps, Fixed-Free Condition)	145
4.34 Mic FWD (Pa) Vs Frequency (Hz) (Aluminum Tube with Dome End Caps, Fixed-Free Condition)	146
4.35 Sound Pressure (Pa) Vs Frequency (Hz) (Aluminum Tube with Dome Ends, Fixed-Free Condition)	147
4.36 Numerical Analysis Mesh for an Aluminum Tube with Dome End Caps (Fixed-Translation Condition)	149
4.37 Mic AFT (dB) Vs Frequency (Hz) (Aluminum Tube with Dome End Caps, Fixed-Translation Condition)	150
4.38 Mic FWD (dB) Vs Frequency (Hz) (Aluminum Tube with Dome End Caps, Fixed-Translation Condition)	151
4.39 Sound Pressure Level (dB) Vs Frequency (Hz) (Aluminum Tube with Dome End Caps, Fixed-Translation Condition)	152

4.40 Mic AFT (Pa) Vs Frequency (Hz) (Aluminum Tube with Dome End Caps, Fixed-Translation Condition)	153
4.41 Mic FWD (Pa) Vs Frequency (Hz) (Aluminum Tube with Dome End Caps, Fixed-Translation Condition)	154
4.42 Sound Pressure (Pa) Vs Frequency (Hz) (Aluminum Tube with Dome End Caps, Fixed-Translation Condition)	155

List of Tables

2.1	Experimental Results for the Aluminum Tube with Flat End Caps (Free-Free Condition) using Acoustic Excitation	23
2.2	Experimental Results for the Aluminum Tube with Flat End Caps (Fixed-Free Condition) using Acoustic Excitation	33
2.3	Experimental Results for the Aluminum Tube with Flat End Caps (Fixed-Translation Condition) using Acoustic Excitation	43
2.4	Experimental Results of Aluminum Tube with Dome End Caps (Free-Free Condition) using Acoustic Excitation	53
2.5	Experimental Results of Aluminum Tube with Dome End Caps (Fixed-Free Condition) using Acoustic Excitation	63
2.6	Experimental Results of Aluminum Tube with Dome End Caps (Fixed-Translation Condition) using Acoustic Excitation	73
4.1	Results of the Numerical Simulation for the Aluminum Tube with Flat End Caps (Free-Free Condition) using Acoustic Excitation	114
4.2	Results of the Numerical Simulation for the Aluminum Tube with Flat End Caps (Fixed-Free Condition) using Acoustic Excitation	122
4.3	Results of the Numerical Analysis of an Aluminum Tube with Flat End Caps (Fixed-Translation Condition) using Acoustic Excitation	130
4.4	Numerical Results of Aluminum Tube with Dome End Caps (Free-Free Condition) using Acoustic Excitation	140
4.5	Results of the Numerical Simulation for an Aluminum Tube with Dome End Caps (Fixed-Free Condition) using Acoustic Excitation	148
4.6	Results of the Numerical Simulation for an Aluminum Tube with Dome End Caps (Fixed-Translation Condition) using Acoustic Excitation	156
5.1	Dynamic Response of Aluminum Cylindrical Tube with Flat End Caps using Acoustic Excitation	157

5.2 Dynamic Response of Aluminum Cylindrical Tube with Dome End Caps using Acoustic Excitation 158

5.3 Dynamic Response of Aluminum Cylindrical Tube using Acoustic Excitation(Experimental Method) 158

5.4 Dynamic Response of Aluminum Cylindrical Tube using Acoustic Excitation(Numerical Anaylsis Method) 159

Chapter 1

Introduction

As with beams and plates, in many branches of engineering, shells are utilized as practical elements when modelling engineering structures, ranging from simple elements such as pipes and ducts, to complex structures such as the bodies of cars, space shuttles, aircraft fuselages, ship hulls, submarines and buildings [1]. However, given that the classical bending theory of shells is governed by an eighth order system of partial differential equations of motion, while the corresponding plate bending theory is only of the fourth order, the dynamic characteristics of shells are inevitably far more complicated than those of beams and plates.

The determination of dynamic characteristics and acoustic properties for cylindrical shells can be important. The main aim of this project is to analyze the dynamic characteristics and acoustic properties of a cylindrical shell with different end cap configurations (Flat and Dome Ends), boundary conditions (Free-Free, Fixed-Free and Fixed-Translation). This study examined the dynamic characteristics and acoustic properties for each of these configurations and boundary conditions.

1.1 Schematic Test Setup for a Cylindrical Shell

In order to experimentally analyze the dynamic characteristics and acoustic properties of the cylindrical shells under different boundary conditions, the experimental setup shown in Figure 1.1 was developed and utilized throughout the study.

The apparatus shown in Figure 1.1 consists of a Bruel & Kjaer Pulse Multi-Analyzer System Type 3560C, Windows System with Bruel & Kjaer Pulse LabShop Software with Reflex -19.0 Version, pyramid stereo power amplifier, speaker, microphones, cylindrical shell

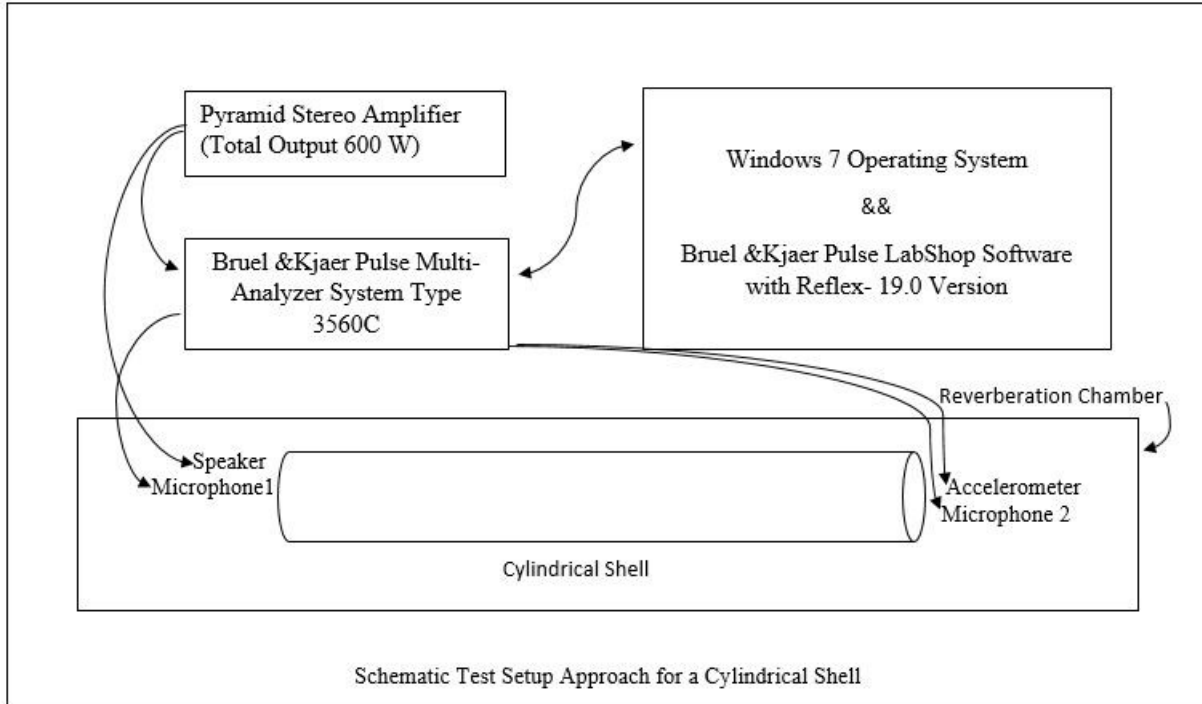

Figure 1.1: Schematic Test Setup

and reverberation chamber. A detailed discussion of the setup and the specifications of the equipment used are provided in the following subsections.

1.1.1 Bruel & Kjaer Pulse Multi-Analyzer System Type 3560C

This PC-Based analyzer system is used to perform noise and vibration measurements. The analysis is determined by the application software packages installed in the system, which include FFT, CPB (octave) and over-all level analyzers. Multiple analyzers of the same type can be used simultaneously, hence its designation as a Multi-Analyzer System Type 3560C.

1.1.2 Bruel & Kjaer Pulse Lab Shop Software with Reflex- 19.0 Version

The PC-based analyzer system Type 3560C is controlled by the Bruel & Kjaer Pulse Lab Shop Software, which runs in a Microsoft system environment. The Noise and Vibration



Figure 1.2: Bruel&Kjaer Pulse Multi-Analyzer System Type 3560C

Type 7700 that is included in the Pulse Lab Shop Software contains a number of tools, including the configuration, measurement, post processing function, display, report organizer and calibration master. Software packages such as FFT, CPB (octave) and Overall level analyzers must be installed along with the Noise and Vibration Type 7700 in order to record measurements and process the data from the Multi-Analyzer System.

1.1.3 FFT Analyzer

FFT analysis is based on the Fast Fourier Transform Algorithm, which is a mathematical method for transforming a function of time into a function of frequency that is utilized for analyzing time-dependent phenomena. FFT analysis is crucial for obtaining the frequency distribution of the power in a sound wave. An FFT analyzer uses constant bandwidth resolution which is useful for vibration analyses because this provides the optimum frequency resolution, facilitating the identification of structural resonances.

An FFT analyzer uses spectrum averaging and measures frequency spectra, measuring auto spectra for signals and cross-spectra for selected pairs of signals. Spectrum averaging is particularly useful for general signal and system analyses.

1.1.4 CPB Analyzer

A CPB Analyzer is used to perform digital filter based fractional octave analysis. In a digital filter-based CPB, although the frequency range measured is set by altering the sampling interval, the digital filters always operate with same relative bandwidth. A number of parallel filtering operations are performed to analyze the frequency range selected; for example, a 1/1-octave analysis requires one band pass filter per octave and a 1/3-octave analysis requires three band pass filters per octave. A CPB analyzer can measure both auto spectra and cross-spectra.

1.1.5 System Calibration

The objective of calibrating the system is to measure the inherent inaccuracies in the various measurement channels (accelerometer and microphone). Regular calibration is required as the sensitivity of instruments and transducers used in a system normally changes over time due to ambient temperature and ageing. The purpose of calibration is to identify the appropriate sensitivity adjustment value (gain adjustment) for each channel. These adjustment values are then used to correct the measurement results to provide meaningful results.

1.1.6 Coherence

Coherence is used to check the measurement conditions and system as a whole. The coherence function is measured in the frequency domain and represents the linear relationship between two signals. Coherence values ranges from 0 to 1, with a value of '1' indicating an ideal system and ideal measurement conditions. A value of '0' indicates no correlation between signals. Coherence values less than '1' indicate that there is a leakage or noise in the measurements and the system is non-linear. Low coherence values indicates poor measurements that should not be relied upon.

1.1.7 Stereo Amplifier (Total Output 600 W)

The stereo amplifier (Total Output 600 W) shown in Figure 1.3 was used in conjunction with the Labshop software described above. Its technical specifications were as follows:

Manufacturer: Pyramid

Model: pB600x Stereo Power Amplifier

Dual Output Level Controls and Illumination

Protection Circuit and Indicator

Power On/Off Switch

Stereo/Mono Selector



Figure 1.3: Pyramid Stereo Amplifier

1.1.8 4" High Power Speaker

In the test setup, a Matrix 4" High Power Speaker was mounted at one end of the cylindrical shell in a wooden box. This consisted of a 20 oz. magnet structure with high quality polymica composite cone with 1" hi-temperature voice coil. The specifications for the speaker as follows:

Manufacture: Matrix

Power- 100 Watts Max/50 Watts RMS

Impedance- 4 Ohm

Efficiency- 87 dB (1 Watt/1 meter)

Frequency Response-110 Hz- 18 KHz.



Figure 1.4: Matrix 4” High Power Speaker

1.1.9 Microphones

In the test setup, Bruel & Kjaer microphones of the type shown in Figure 1.5 were placed at both ends of the cylindrical shell in such a way that the face of the microphone was flush with the end surface of the cylindrical shell. One microphone was placed alongside with the speaker in the wooden box and the other at the opposite end of the cylindrical shell. The microphone specification were as follows:

Technical Specification of Microphone at Speaker End:

Manufacturer: Bruel & Kjaer

Prepolarized Microphone Type 4188-L-001

Serial No: 2381450

Gain Adjust- 0.9874

Nom.Sensitivity-31.6 m V/Pa

Max Peak Input- 7.071 V

HP Filter- 22.4 Hz.

Technical Specification of Microphone at Opposite to Speaker End:

Manufacturer: Bruel & Kjaer

Prepolarized Microphone Type 4188-L-001

Serial No: 2381451

Gain Adjust- 1.055

Nom.Sensitivity-31.6 m V/Pa

Max Peak Input- 7.071 V

HP Filter- 22.4 Hz.



Figure 1.5: Bruel & Kjaer Microphone Type 4188L-001

1.1.10 Piezoelectric Accelerometer

In the test setup, an Endevco Piezoelectric Accelerometer, shown in Figure 1.6, was placed at the end of the cylinder opposite to the speaker end of the cylindrical shell. The accelerometer's technical specifications were as follows:

Manufacturer: ENDEVCO

Piezoelectric Accelerometer

Model No- 2226C

Serial Number- 17746

Gain Adjust- 0.9202

External Amplifier Gain- 10G V/C

Max Peak Input- 7.071 V

HP Filter- 22.4 Hz



Figure 1.6: ENDEVCO Piezoelectric Accelerometer

1.1.11 HP Compaq 8200 Elite Windows based System

In the test setup, an HP Compaq 8200 Elite windows 7 based operating system was used along with the Bruel & Kjaer Pulse LabShop Software with Reflex in order to perform the data analysis. The computer's system configuration was as follows:

Model - HP Compaq 8200 Elite

Operating System Windows 7

CPU-8 core 2.80 GHz Intel Core i7-2600s

Service Pack 1

RAM- 8078 MB

Hard Disk-500 GB

1.1.12 Reverberation Room

A reverberation room is a room specifically designed for use in acoustic experiments that facilitates the evaluation of the sound absorption coefficient and the sound transmission loss of acoustic material. It has reflective walls, floor and ceiling to recreate the conditions required for a diffuse sound field within a limited space. In a reverberation room, where the energy of an incoming sound comes from a number of different directions, the reverberation time is extremely long and the sound pressure level distribution is almost uniform. Reverberation rooms are designed for determining the noise output of sound sources, the

transmission loss of partitions, the insertion loss of silencers, the response characteristics of microphones, and the random incidence absorption coefficients of materials.

The experimental setup was assembled in a reverberation room in the Acoustic Lab in order to ensure the sound pressure was equal over the entire surface, including inside and the outside the tubes. The reverberation room used for this experiment had a volume of 53 m^3 , shown in Figure 1.7.



Figure 1.7: Outside view of the reverberation chamber

1.1.13 CAD Drawings of Cylindrical Tube

This subsection provides selected drawings of the flat and dome end tubes and their end caps. Figure 1.8 is a front view of the dome end tube. The aluminum cylinder is 60 in. in length and 6 in. in diameter. The dome had an inner radius of 5.25 in.

Fig 1.9 is a front view of the dome end cap. The cutout in the center is for the speaker, which was mounted on the end cap.

Fig 1.10 is a front view of the flat end tube. This tube had the same length and diameter as the dome end tube.

Fig 1.11 is a front view of the flat end cap. There were cutouts made for the speaker and microphone similar to the dome end cap.

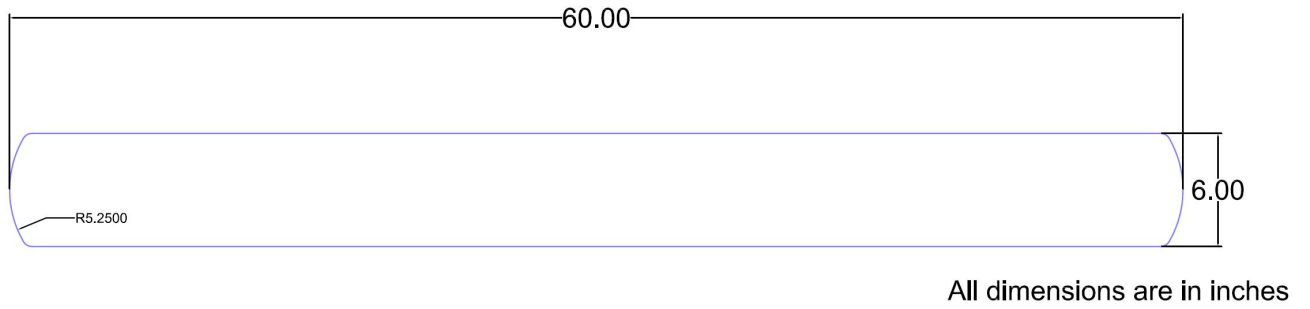

Figure 1.8: Cylindrical Tube with Dome Ends

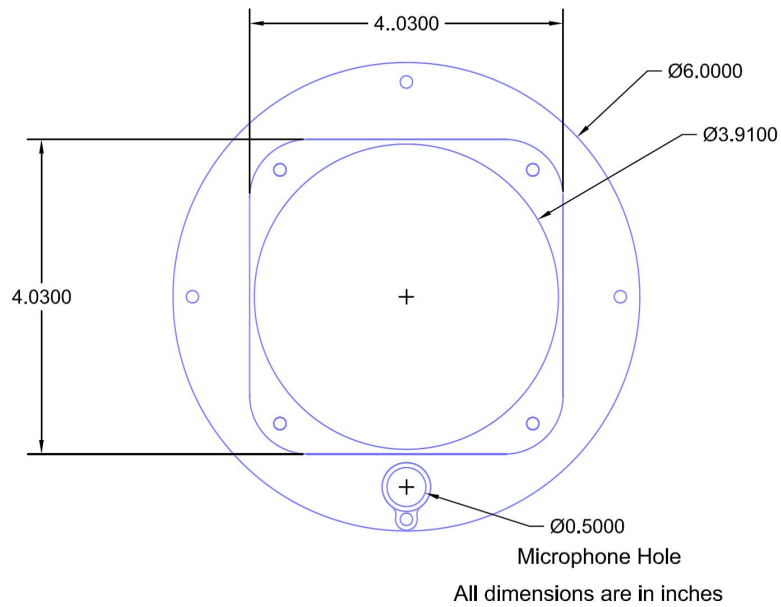

Figure 1.9: Dome End with Speaker Setup

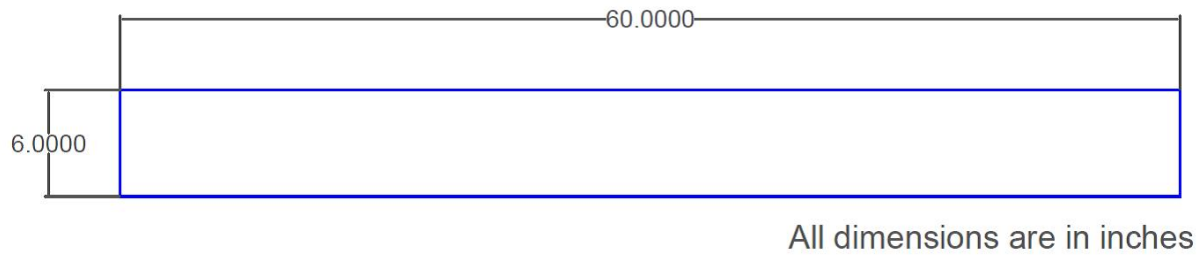

Figure 1.10: Cylindrical Tube with Flat Ends

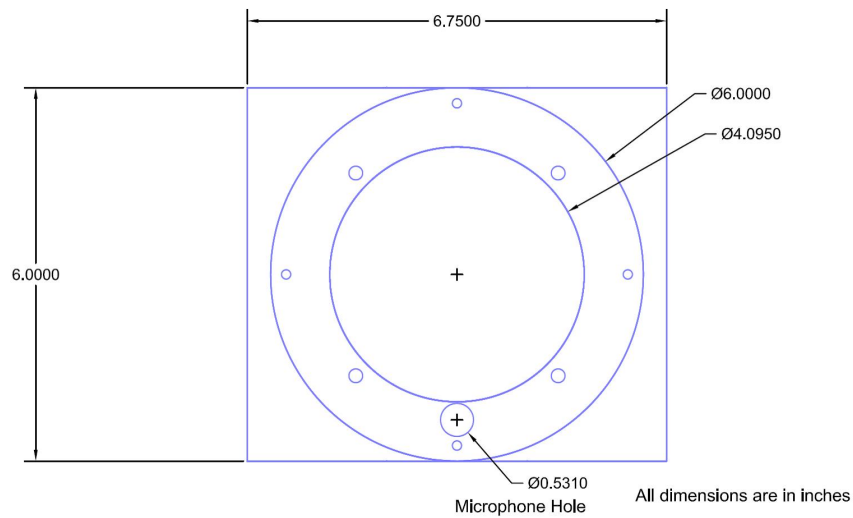

Figure 1.11: Flat End with Speaker Setup

1.1.14 Setup Conditions

The aluminum tubes with flat and dome end caps were subjected to the following boundary conditions.

- a. Free- Free Condition.
- b. Fixed- Free Condition.
- c. Fixed- Translation Condition.

Pictures of each of these conditions will be shown in Chapter 2.

Aluminum tubes were subjected to fixed-free and fixed-translation conditions using jack-stands as shown in Figure 1.12.



Figure 1.12: Pictures of the jack stand with the fixture to hold the tube

Chapter 2

Dynamic Response of Aluminum Tubes using Acoustic Excitation

To better understand the acoustic field inside thin walled cylindrical tubes, experiments were conducted using aluminum cylindrical tubes . In this chapter, we discuss the experiments conducted using the aluminum tubes shown in Section 1.1.13 for different boundary conditions and end cap configurations.

The two end cap configurations used for the aluminum cylinders were:

1. Flat end caps
2. Dome end caps

2.1 Aluminum Tube with Flat End Cap Configuration

The three different boundary conditions applied at the ends of the aluminum tubes were:

- (i) Free-Free
- (ii) Fixed-Free
- (iii) Fixed-Translation

2.1.1 Free-Free Boundary Condition

Experimental Setup:

Tests were conducted on an aluminum circular cylindrical shell with material properties as follows: Young's Modulus = 1×10^7 psi, Density = 0.1 lb/in^3 and Poisson's ratio = 0.33. The experimental setup is shown in Figures 2.1, 2.2 and 2.3.



Figure 2.1: Free-Free Experimental Setup

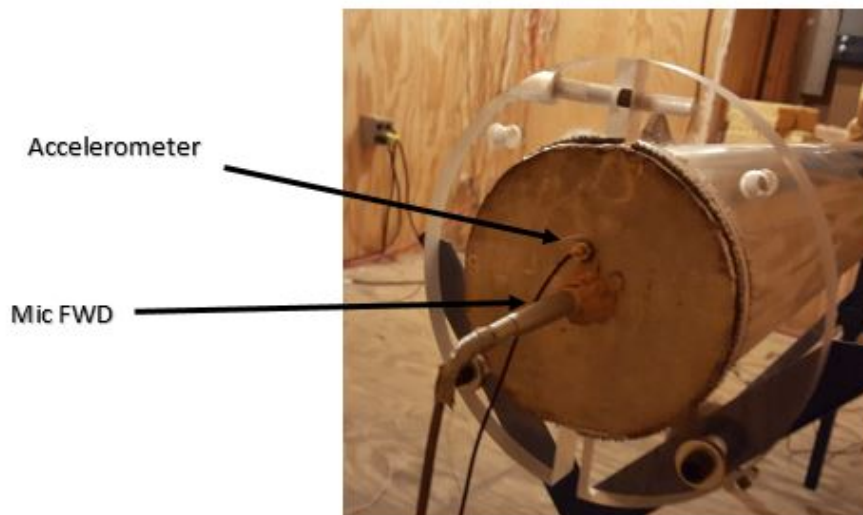

Figure 2.2: FWD End Setup

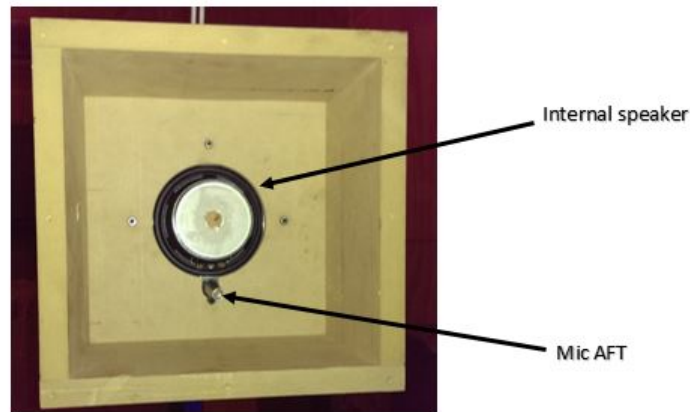

Figure 2.3: Internal loudspeaker Setup (AFT End)

A frequency range of 0-800 Hz was used for the frequency response measurements and an FFT analysis with a frequency resolution of 0.5 Hz averaged over 10,000 readings across the time domain was conducted.

Results:

Figures 2.4 and 2.5 show the results for Sound Level (dB) versus Frequency (Hz) for the AFT and FWD microphones, respectively, in the aluminum tube with flat ends. The first peak was recorded at a sound level of 97.230 dB at 95 Hz for Mic AFT (AFT microphone) and 99.288 dB at 91.5 Hz for Mic FWD (FWD microphone). Figure 2.6 is a composite of Figures 2.4 and 2.5 comparing the sound levels recorded by the AFT and FWD microphones.

Figures 2.7 and 2.8 show the results for Sound Pressure (Pa) versus Frequency (Hz) for the AFT and FWD microphones, respectively, in the aluminum tube with flat ends. The first peak pressure was recorded as 1.454 Pa at 95 Hz for Mic AFT and 1.843 Pa at 91.5 Hz for Mic FWD. Figure 2.9 is a composite of Figures 2.7 and 2.8 comparing the sound pressures recorded by the AFT and FWD microphones.

Figure 2.10 shows the Acceleration (m/s^2) versus Frequency (Hz) for the accelerometer placed at the FWD end of the aluminum tube with flat ends.

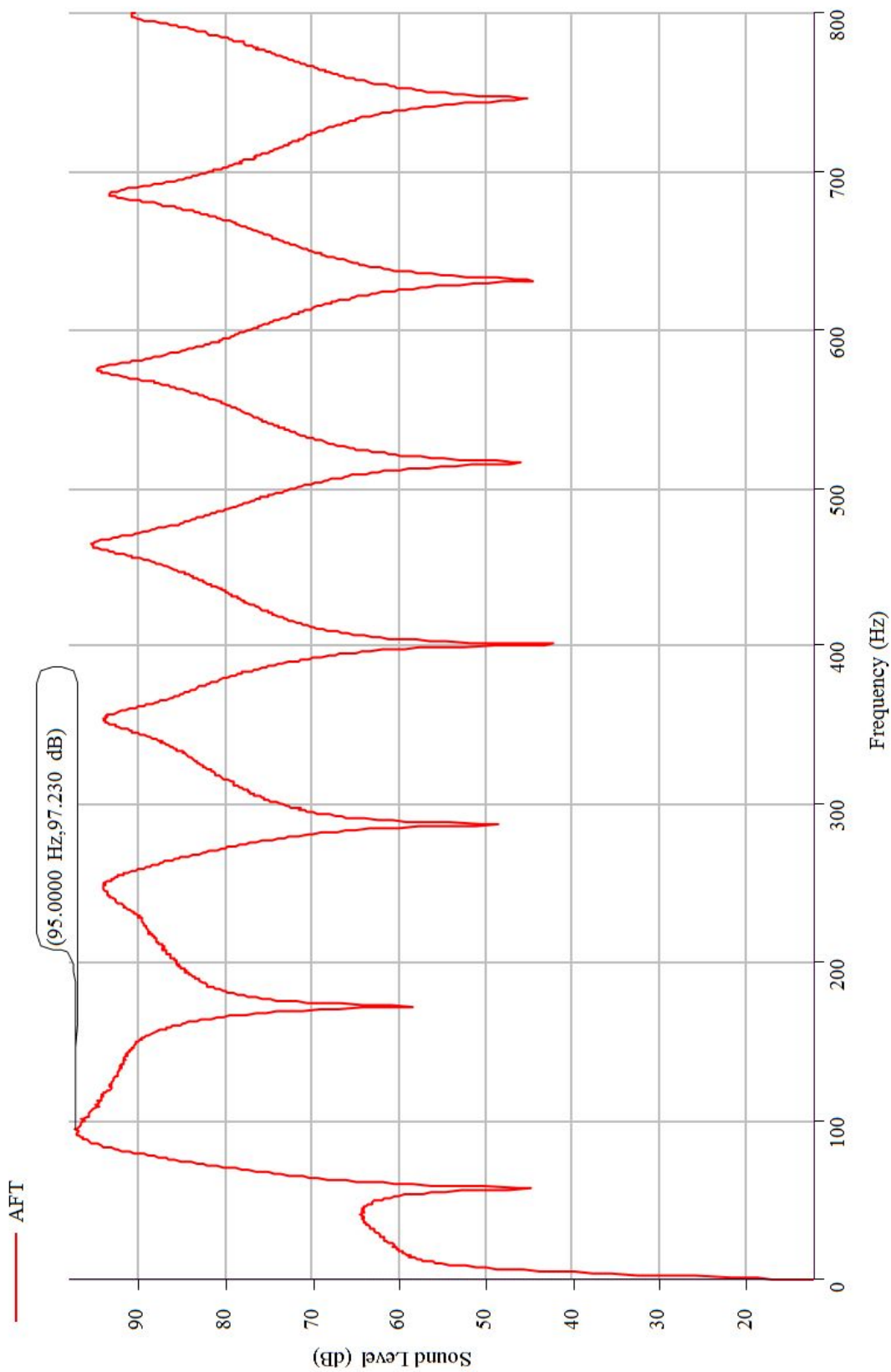

Figure 2.4: Mic AFT (dB) Vs Frequency (Hz) (Aluminum Tube with Flat End Caps, Free-Free Condition),

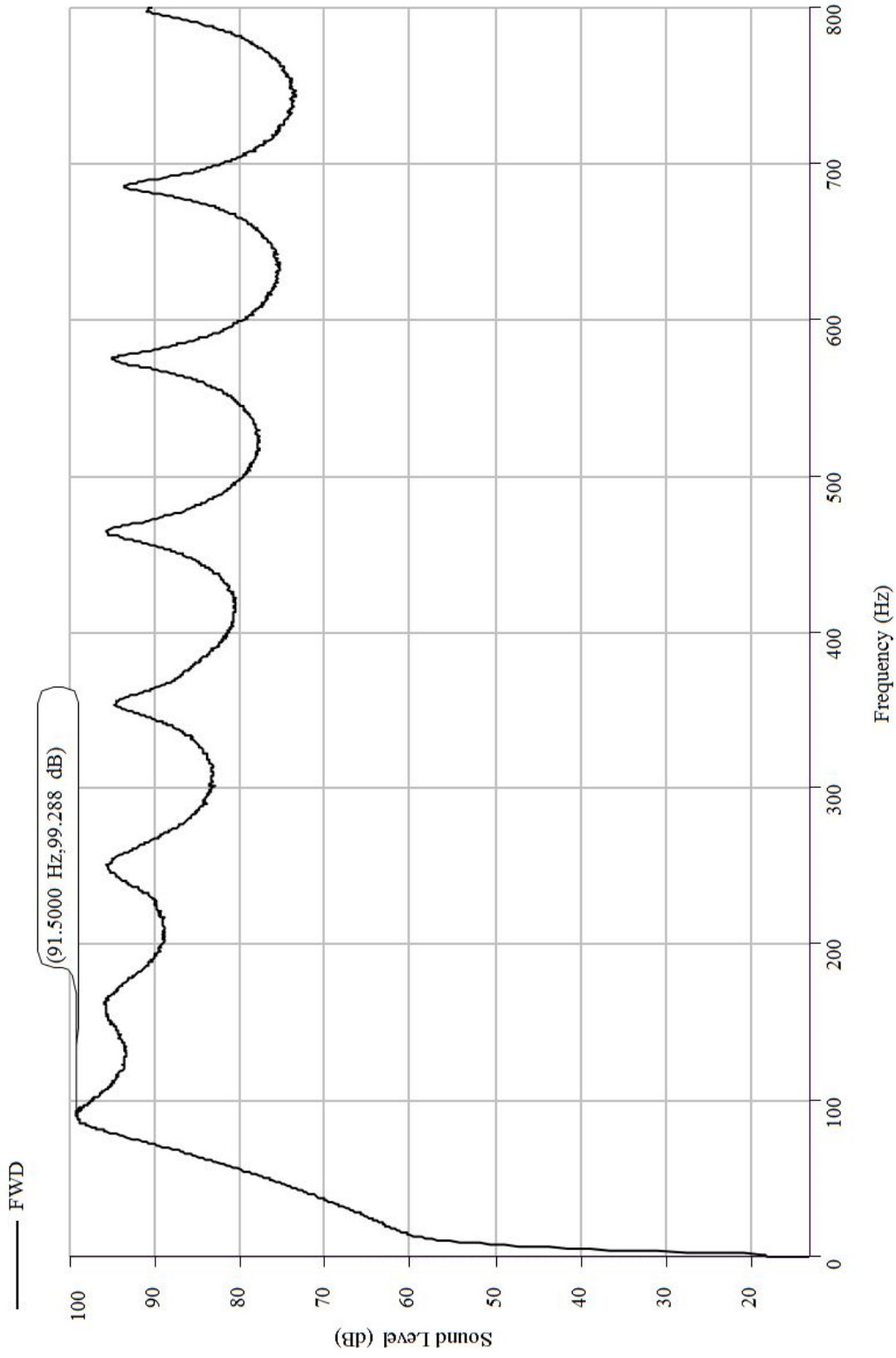

Figure 2.5: Mic FWD (dB) Vs Frequency (Hz) (Aluminum Tube with Flat End Caps, Free-Free Condition)

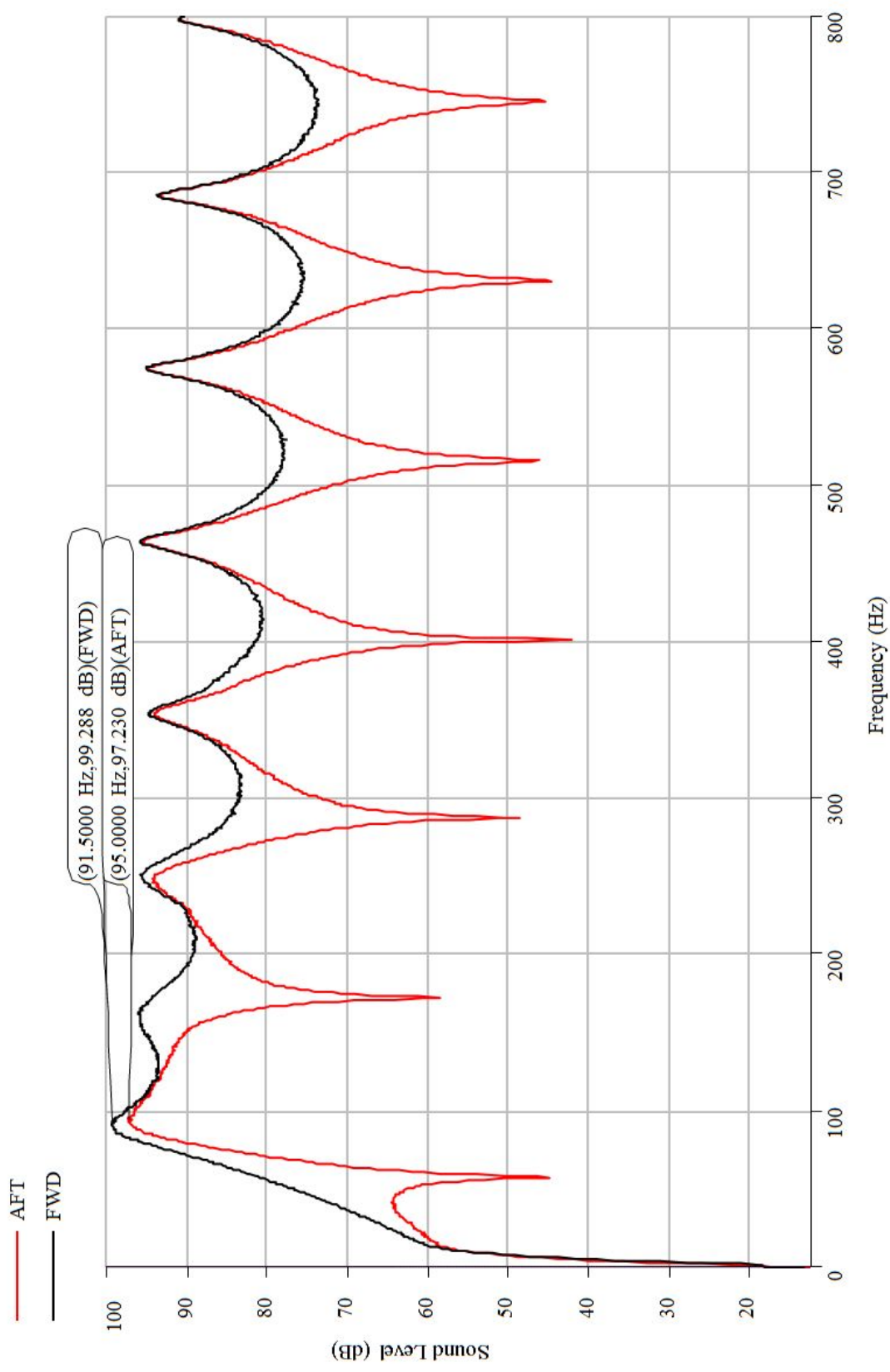

Figure 2.6: Sound Pressure Level (dB) Vs Frequency (Hz) (Aluminum Tube with Flat End Caps, Free-Free Condition)

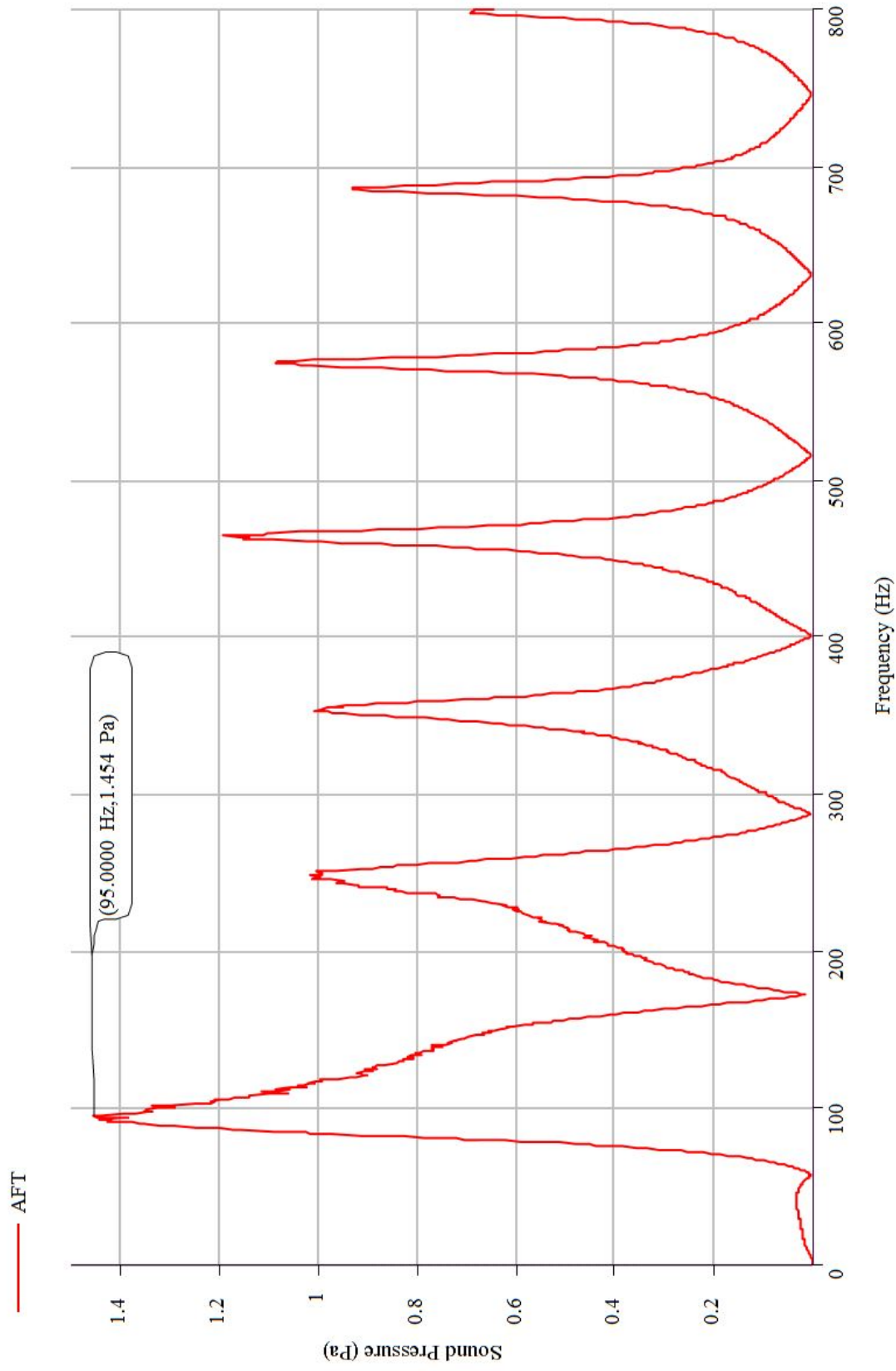

Figure 2.7: Mic AFT (Pa) Vs Frequency (Hz) (Aluminum Tube with Flat End Caps, Free-Free Condition)

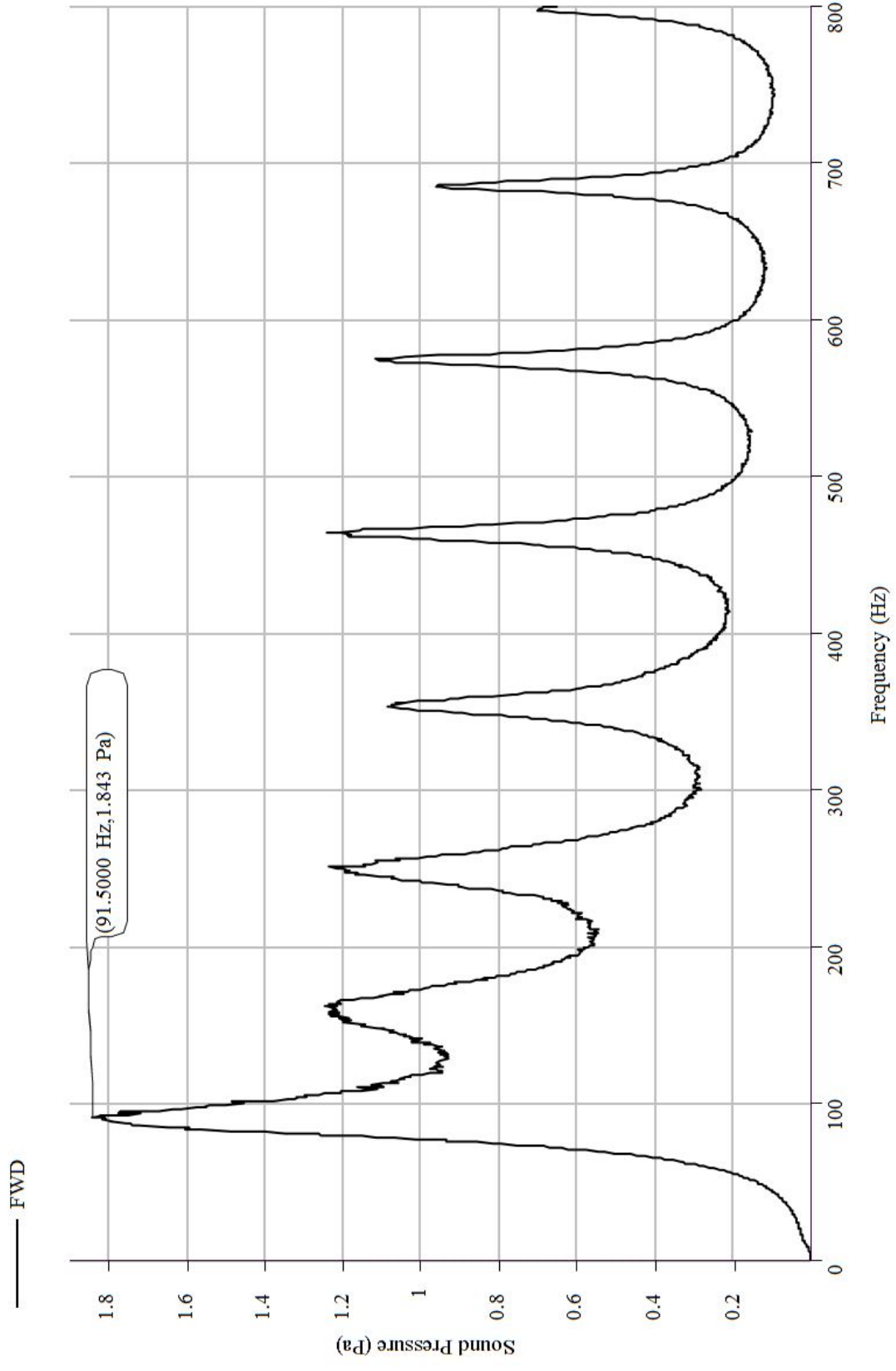

Figure 2.8: Mic FWD (Pa) Vs Frequency (Hz) (Aluminum Tube with Flat End Caps, Free-Free Condition)

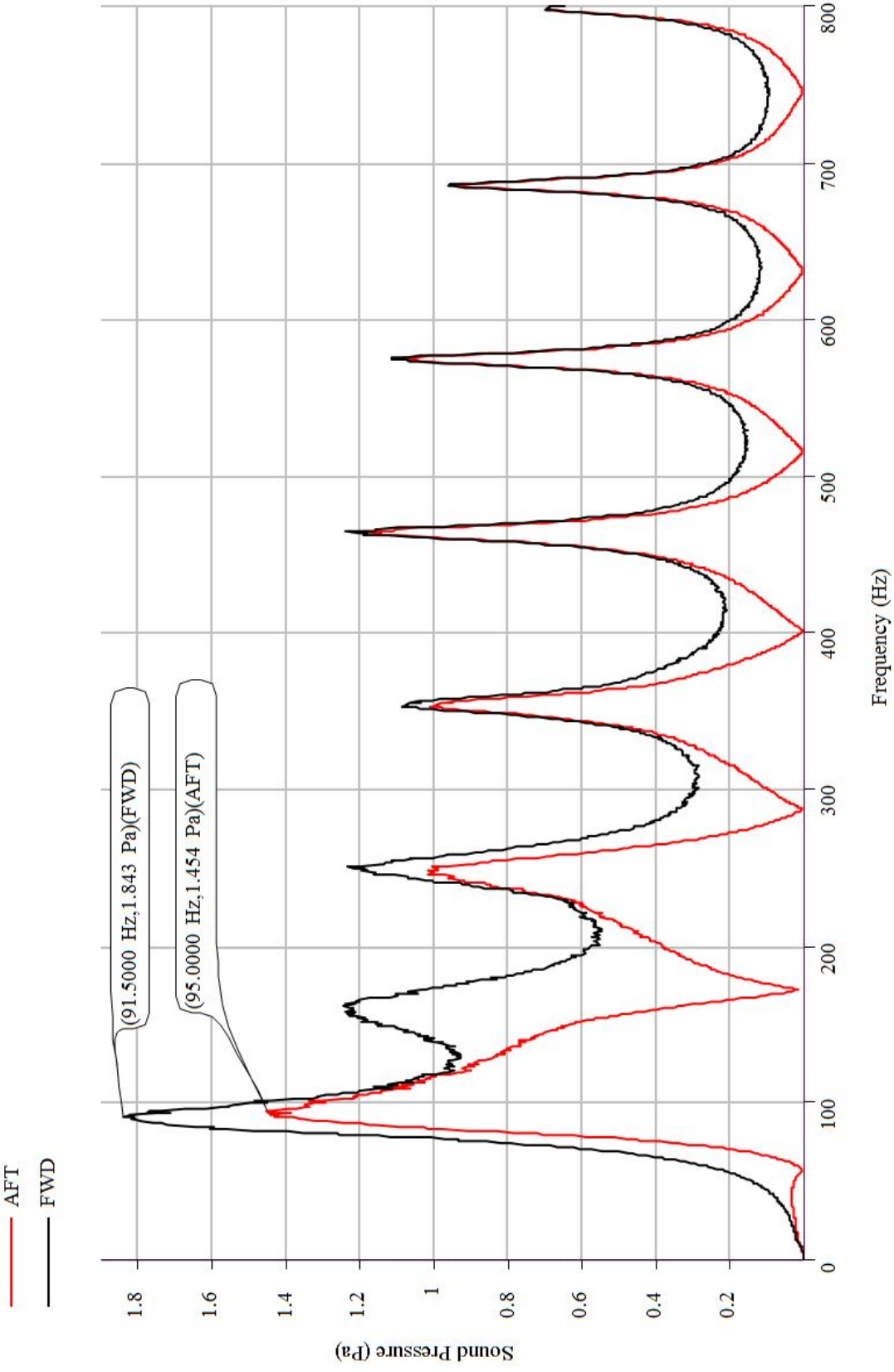

Figure 2.9: Sound Pressure (Pa) Vs Frequency (Hz) (Aluminum Tube with Flat End Caps, Free-Free Condition)

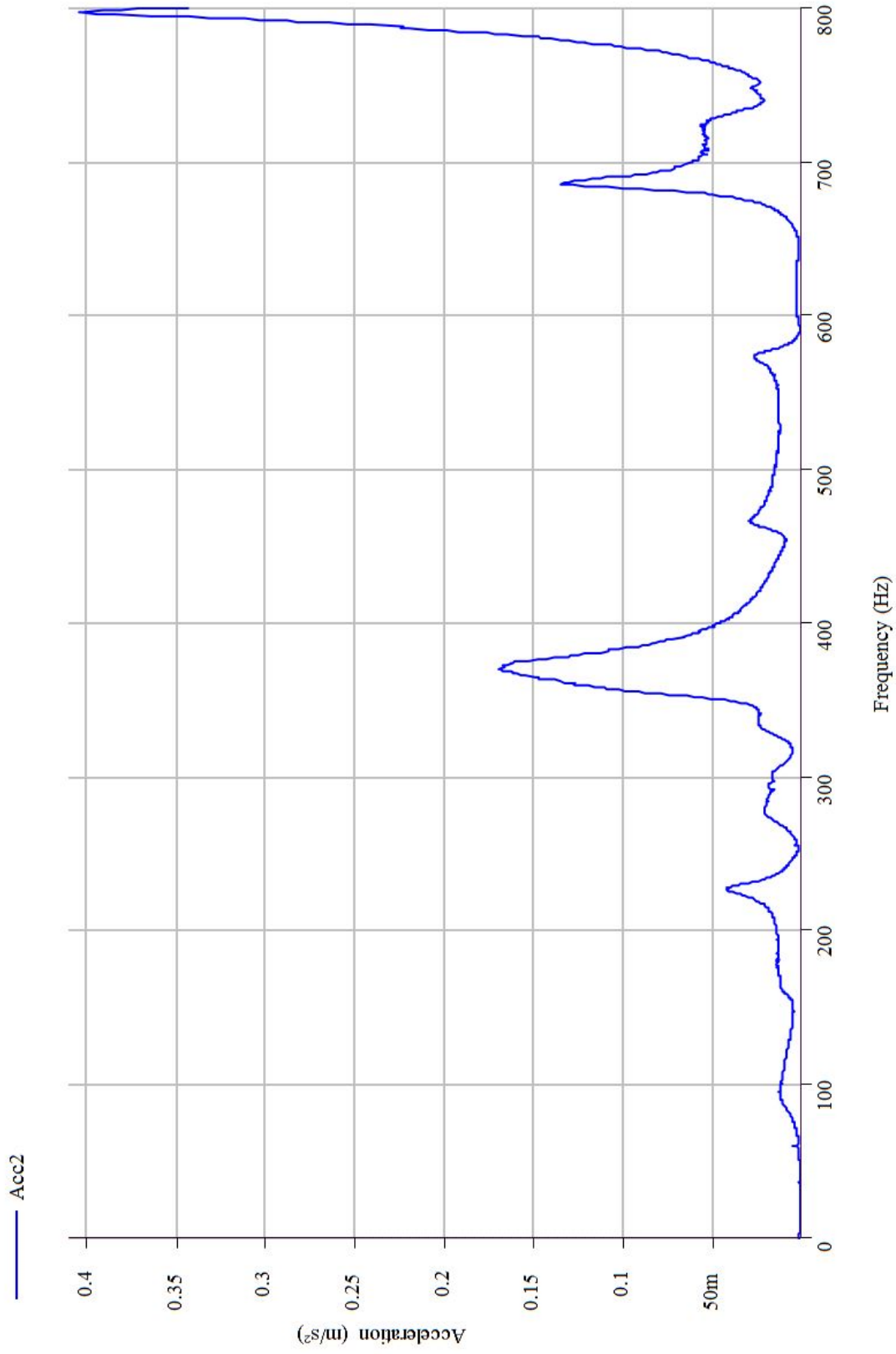

Figure 2.10: Acceleration (m/s^2) Vs Frequency (Hz) (Aluminum Tube with Flat End Caps, Free-Free Condition)

Summary of Results

Table 2.1 shows the results for the aluminum tube with flat end caps (Free-Free Condition) using acoustic excitation.

Aluminum Tube with Flat End Caps using Acoustic Excitation		
	Experimental Results	
	Sound Pressure Level(dB)	Sound Pressure (Pa)
Free-Free Condition	97.230 dB at 95 Hz (Mic AFT)	1.454 Pa at 95 Hz (Mic AFT)
	99.288 dB at 91.5 Hz (Mic FWD)	1.843 Pa at 91.5 Hz (Mic FWD)

Table 2.1: Experimental Results for the Aluminum Tube with Flat End Caps (Free-Free Condition) using Acoustic Excitation

2.1.2 Fixed-Free Boundary Condition

Experimental Setup:

The experimental setup for an aluminum tube with flat end caps for the fixed-free condition is shown in Figure 2.11.



Figure 2.11: Fixed-Free Experimental Setup

Results:

Figures 2.12 and 2.13 show the results for Sound Level (dB) versus Frequency (Hz) for the AFT and FWD microphones, respectively, in the aluminum tube with flat ends. The first peak was recorded at a sound level of 97.160 dB at 95 Hz for Mic AFT and 99.180 dB at 91.5 Hz for Mic FWD. Figure 2.14 is a composite of Figures 2.12 and 2.13 comparing the sound levels recorded by the AFT and FWD microphones.

Figures 2.15 and 2.16 show the results for Sound Pressure (Pa) versus Frequency (Hz) for the AFT and FWD microphones, respectively, in the aluminum tube with flat ends. The first peak pressure was recorded as 1.442 Pa at 95 Hz for Mic AFT and 1.821 Pa at 91.5 Hz

Hz for Mic FWD. Figure 2.17 is a composite of Figures 2.15 and 2.16 comparing the sound pressures recorded by the AFT and FWD microphones.

Figure 2.18 shows the Acceleration (m/s^2) versus Frequency (Hz) for the accelerometer placed at the FWD end in the aluminum tube with flat ends.

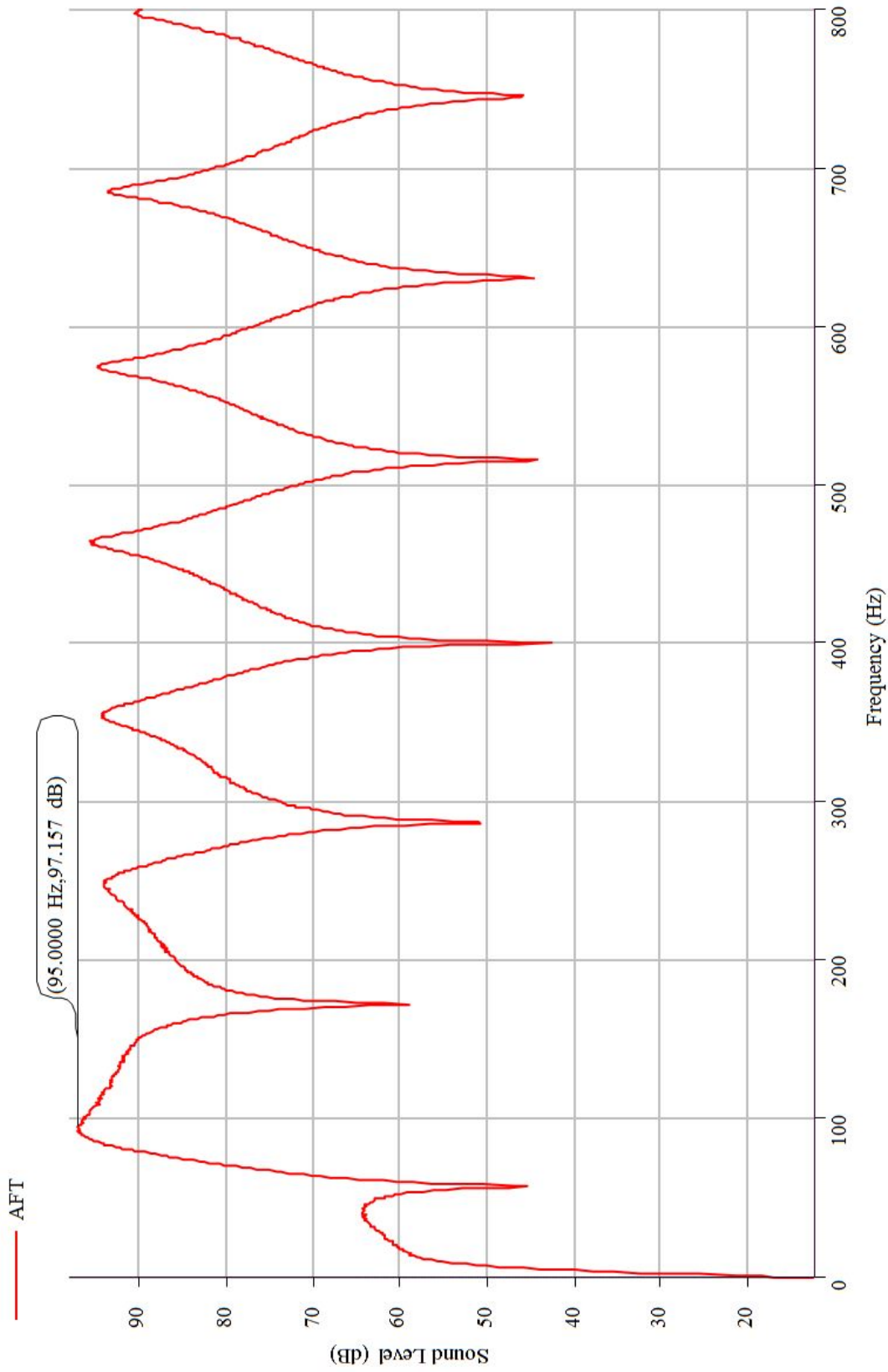

Figure 2.12: Mic AFT (dB) Vs Frequency (Hz) (Aluminum Tube with Flat End Caps, Fixed-Free Condition)

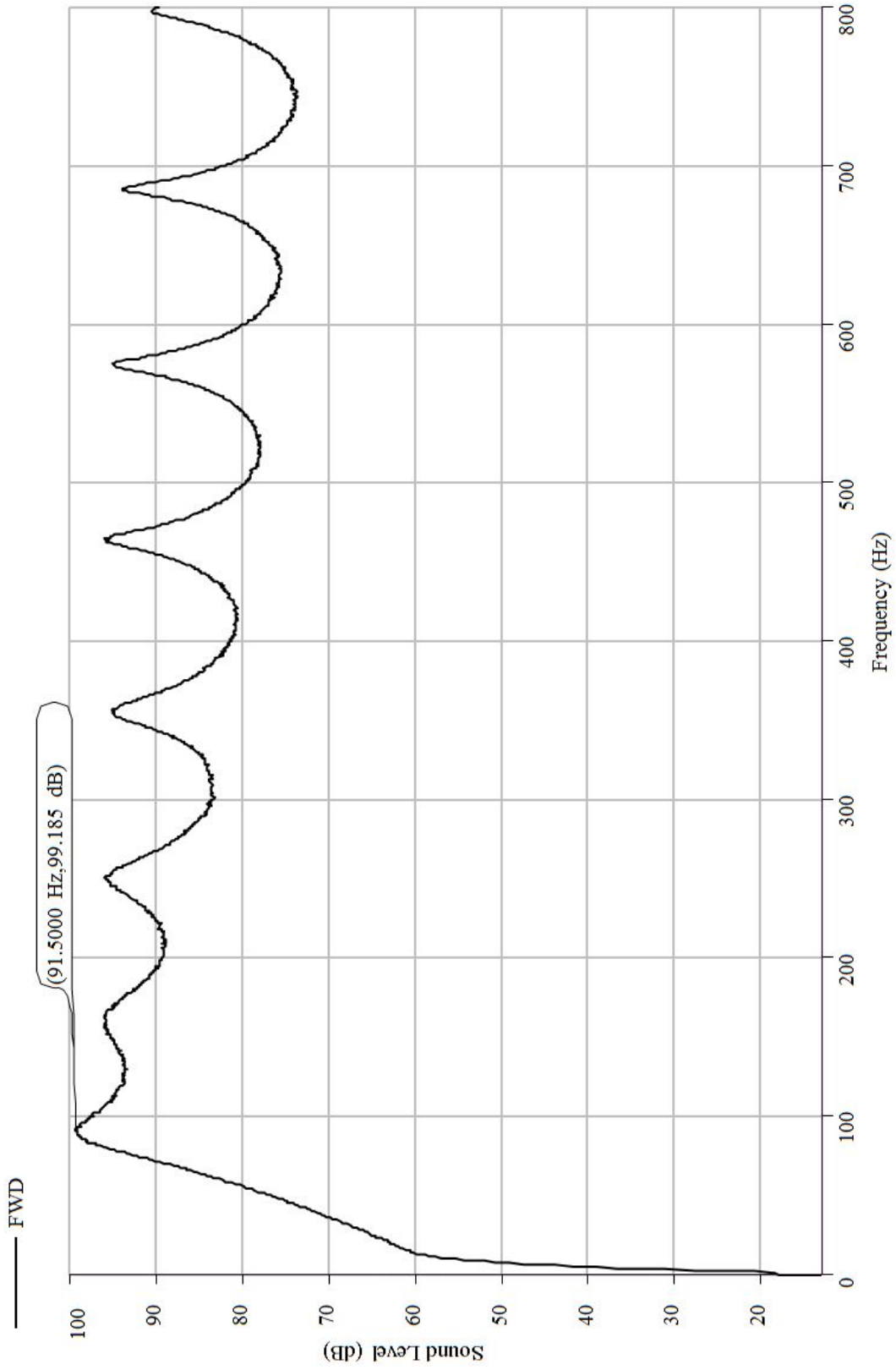

Figure 2.13: Mic FWD (dB) Vs Frequency (Hz) (Aluminum Tube with Flat End Caps, Fixed-Free Condition)

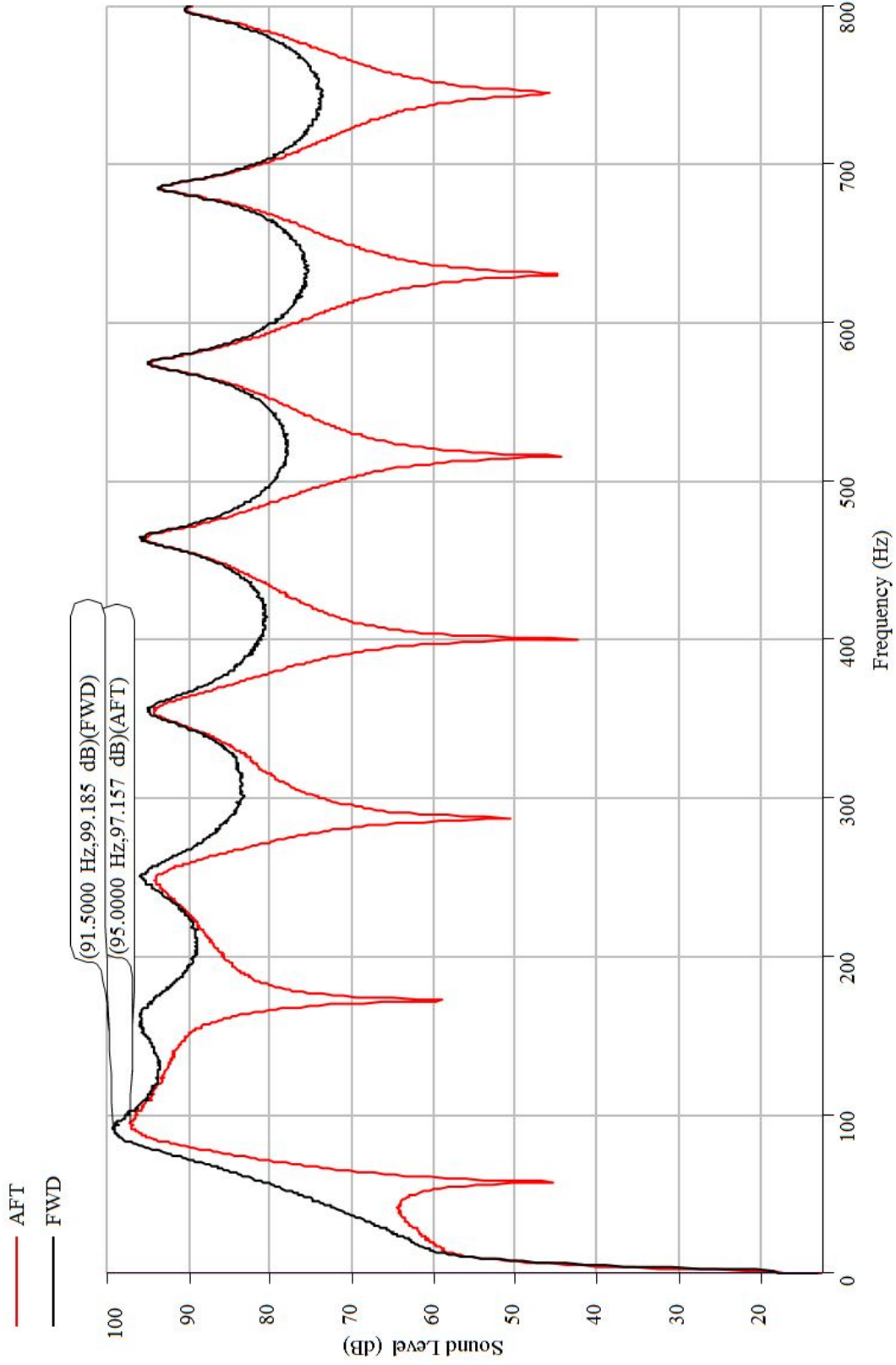

Figure 2.14: Sound Pressure Level (dB) Vs Frequency (Hz) (Aluminum Tube with Flat End Caps, Fixed-Free Condition)

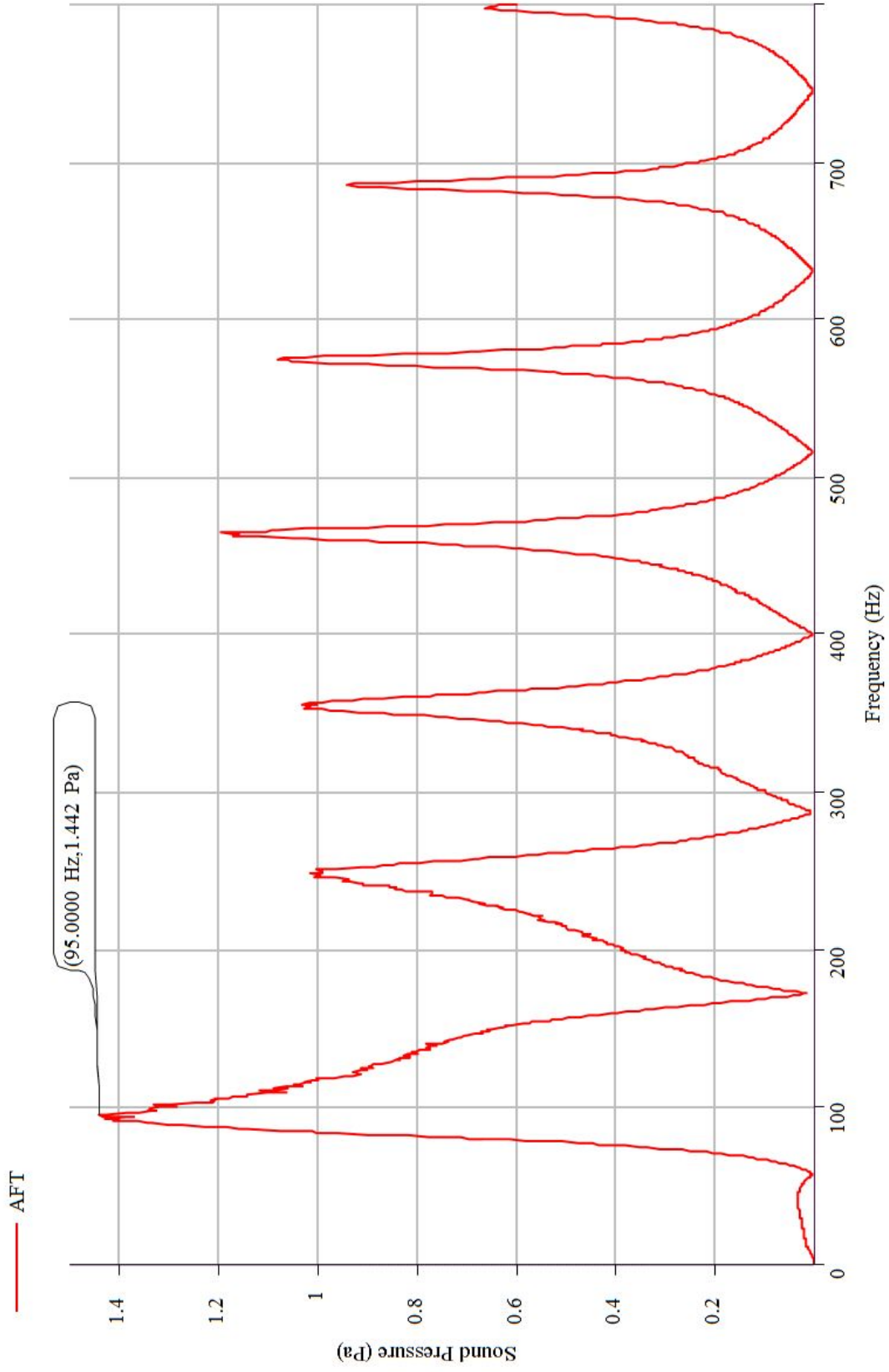

Figure 2.15: Mic AFT (Pa) Vs Frequency (Hz) (Aluminum Tube with Flat End Caps, Fixed-Free Condition)

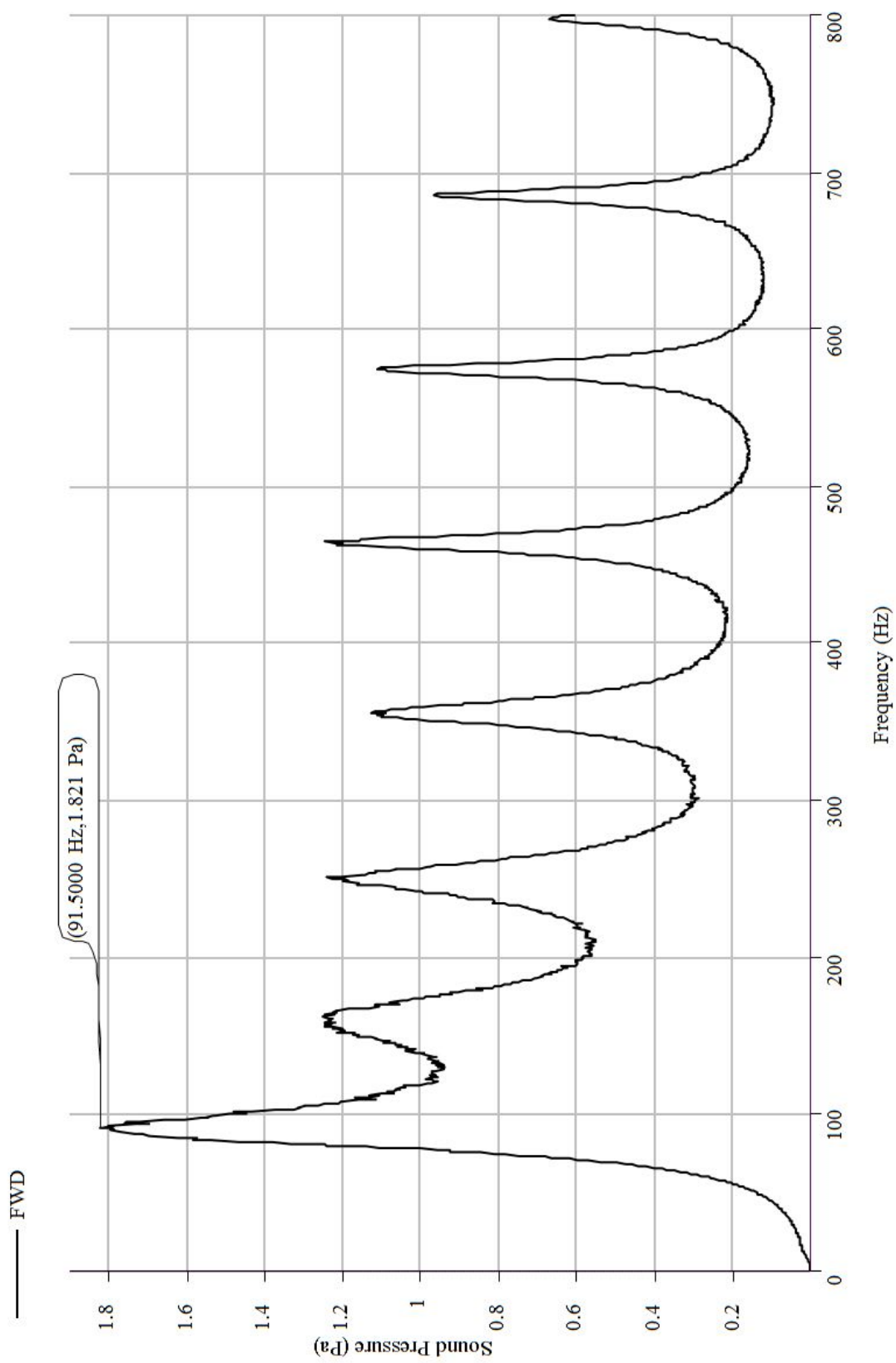

Figure 2.16: Mic FWD (Pa) Vs Frequency (Hz) (Aluminum Tube with Flat End Caps, Fixed- Free Condition)

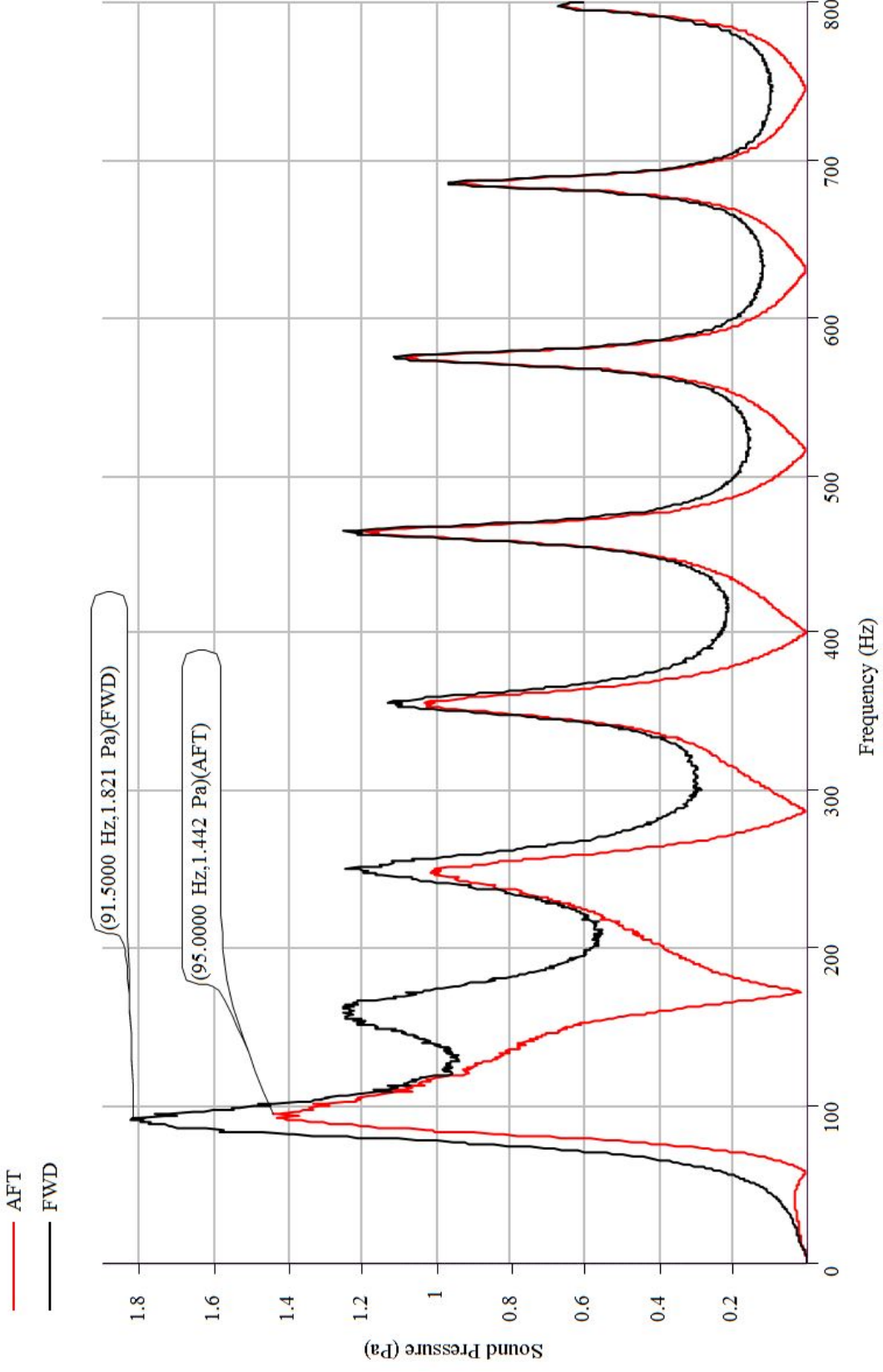

Figure 2.17: Sound Pressure (Pa) Vs Frequency (Hz) (Aluminum Tube with Flat End Caps, Fixed- Free Condition)

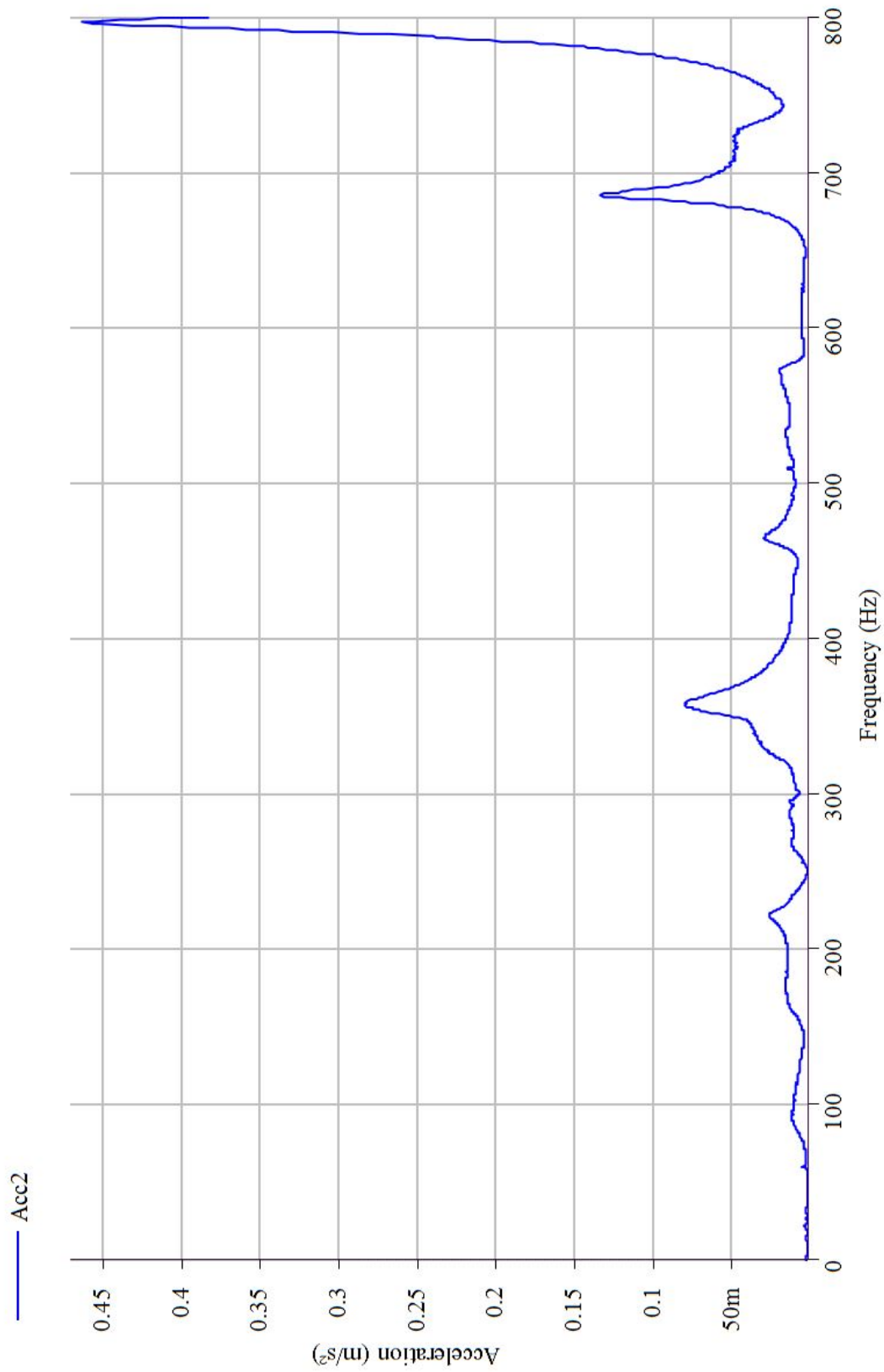

Figure 2.18: Acceleration (m/s^2) Vs Frequency (Hz) (Aluminum Tube with Flat End Caps, Fixed- Free Condition)

Summary of Results

Table 2.2 shows the results for the aluminum tube with flat end caps (Fixed-Free Condition) using acoustic excitation.

Aluminum Tube with Flat End Caps using Acoustic Excitation		
	Experimental Results	
	Sound Pressure Level(dB)	Sound Pressure (Pa)
Fixed-Free Condition	97.16 dB at 95 Hz (Mic AFT)	1.442 Pa at 95 Hz (Mic AFT)
	99.18 dB at 91.5 Hz (Mic FWD)	1.821 Pa at 91.5 Hz (Mic FWD)

Table 2.2: Experimental Results for the Aluminum Tube with Flat End Caps (Fixed-Free Condition) using Acoustic Excitation

2.1.3 Fixed-Translation Boundary Condition

Experimental Setup:

The experimental setup for an aluminum tube with flat end caps for the fixed-translation condition is shown in Figure 2.19



Figure 2.19: Fixed-Translation Experimental Setup

Results:

Figures 2.20 and 2.21 show the results for Sound Level (dB) versus Frequency (Hz) for the AFT and FWD microphones, respectively, in the aluminum tube with flat end caps. The first peak was recorded at a sound level of 97.138 dB at 95 Hz for Mic AFT and 99.174 dB at 91.5 Hz for Mic FWD. Figure 2.22 is a composite of Figures 2.20 and 2.21 comparing the sound levels recorded at the AFT and FWD microphones.

Figures 2.23 and 2.24 show the results for Sound Pressure (Pa) versus Frequency (Hz) for the AFT and FWD microphones, respectively, in the aluminum tube with flat end caps. The first peak pressure was recorded as 1.439 Pa at 95 Hz for Mic AFT and 1.819 Pa at 91.5 Hz for Mic FWD. Figure 2.25 is a composite of Figures 2.23 and 2.24 comparing the sound pressures recorded at the AFT and FWD microphones.

Figure 2.26 shows the Acceleration (m/s^2) versus Frequency (Hz) for the accelerometer placed at the FWD end in the aluminum tube with flat end caps.

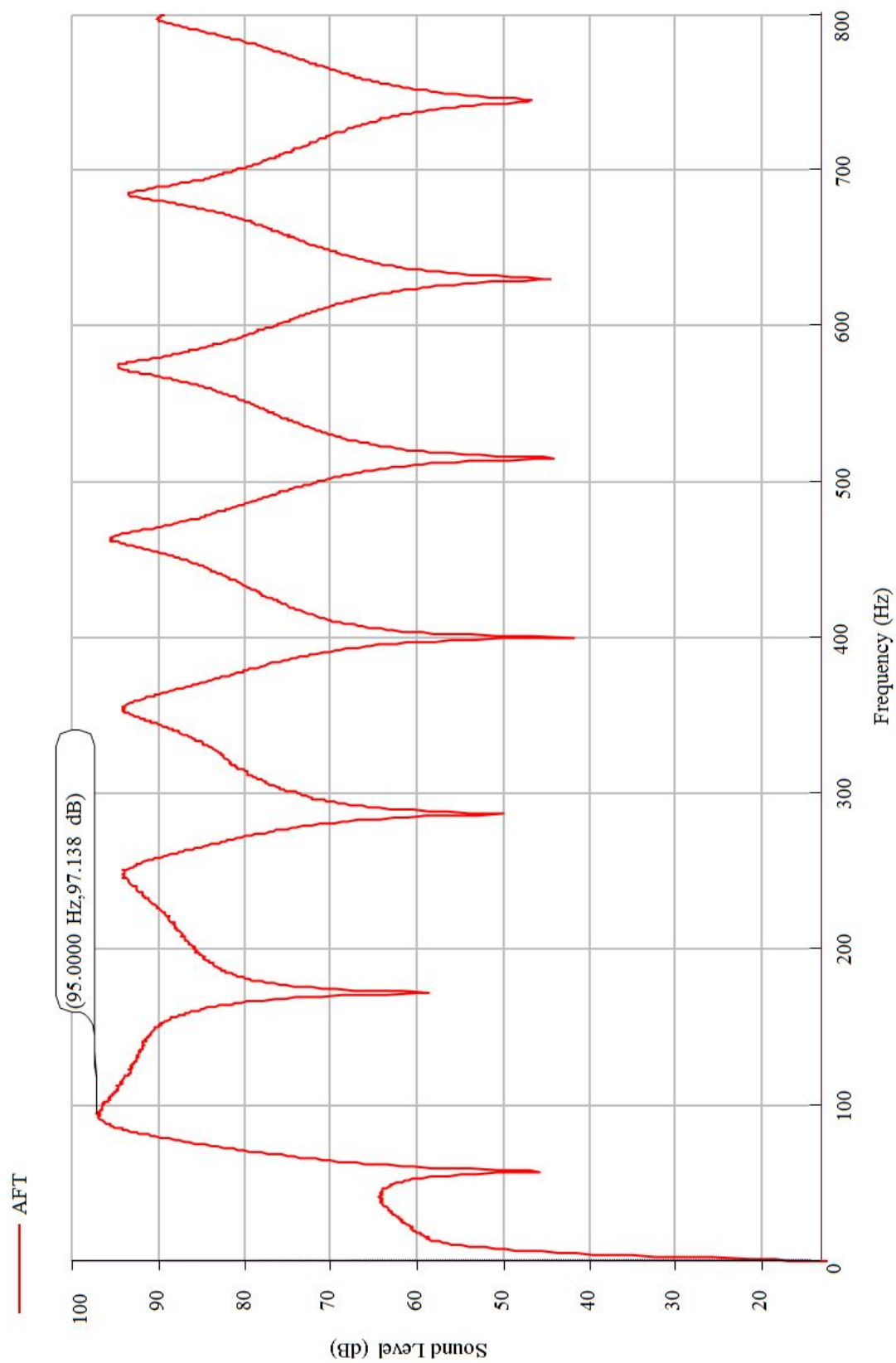

Figure 2.20: Mic AFT (dB) Vs Frequency (Hz) (Aluminum Tube with Flat End Caps, Fixed-Translation Condition)

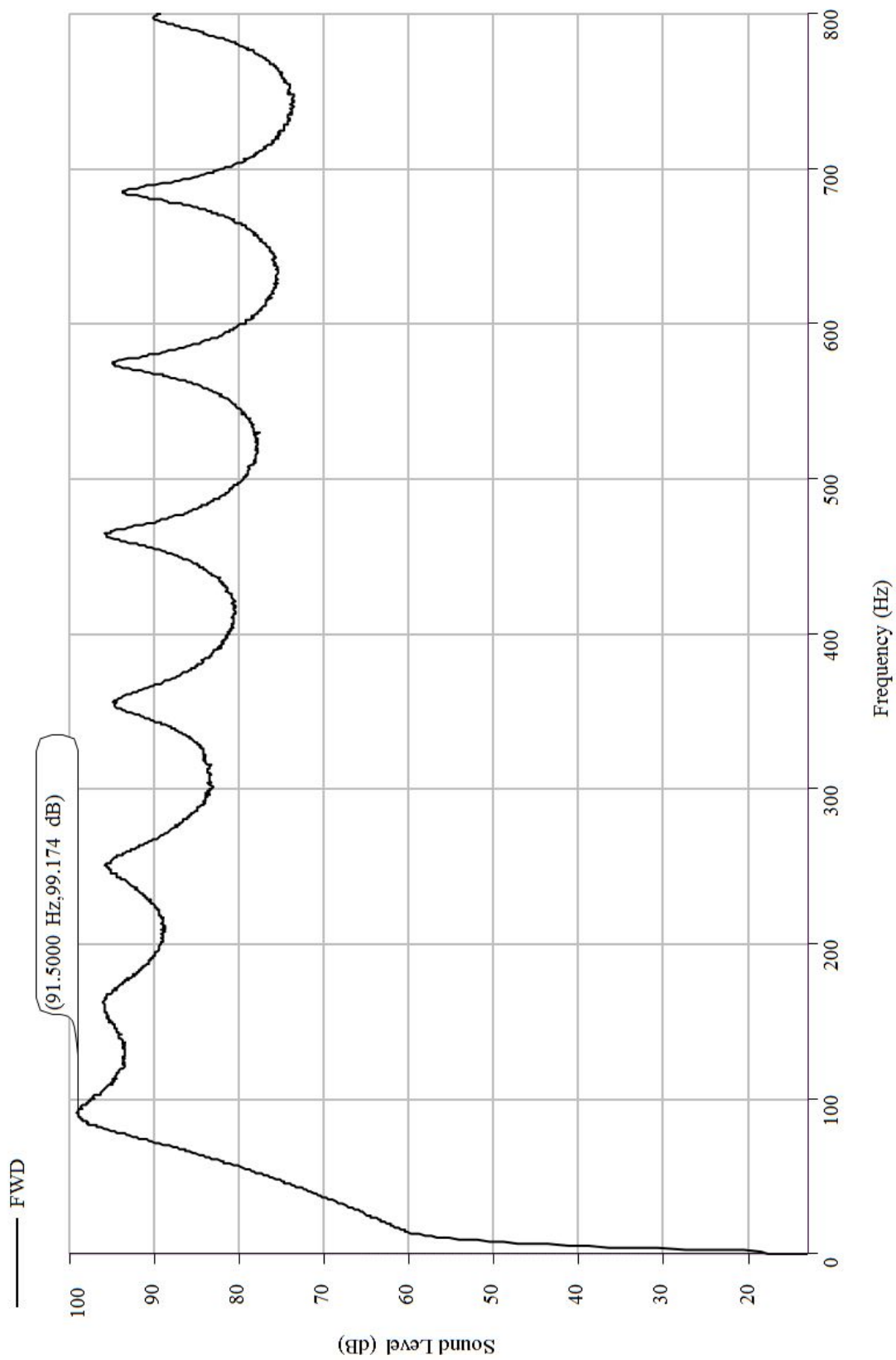

Figure 2.21: Mic FWD (dB) Vs Frequency (Hz) (Aluminum Tube with Flat End Caps, Fixed-Translation Condition)

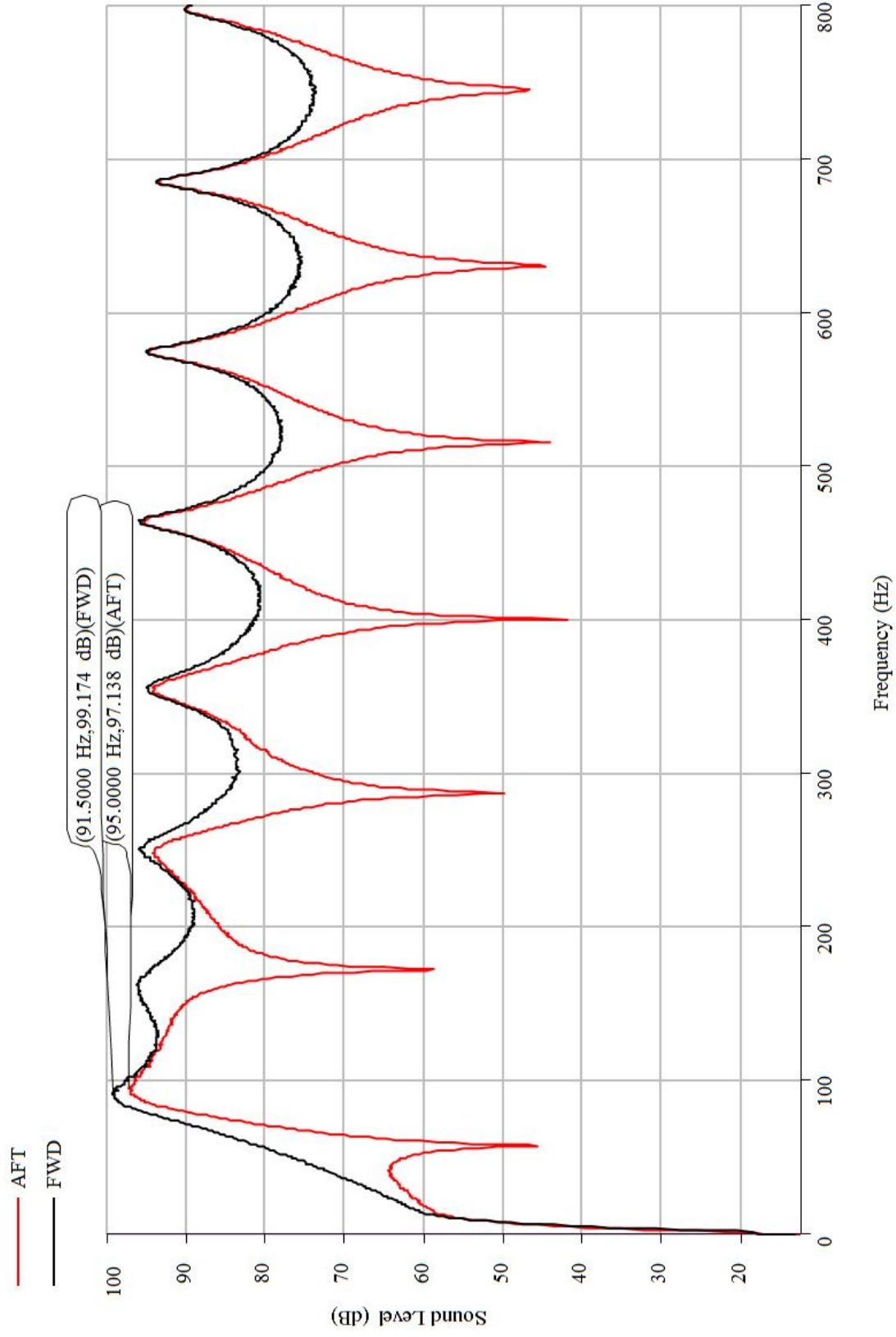

Figure 2.22: Sound Pressure Level (dB) Vs Frequency (Hz) (Aluminum Tube with Flat End Caps, Fixed-Translation Condition)

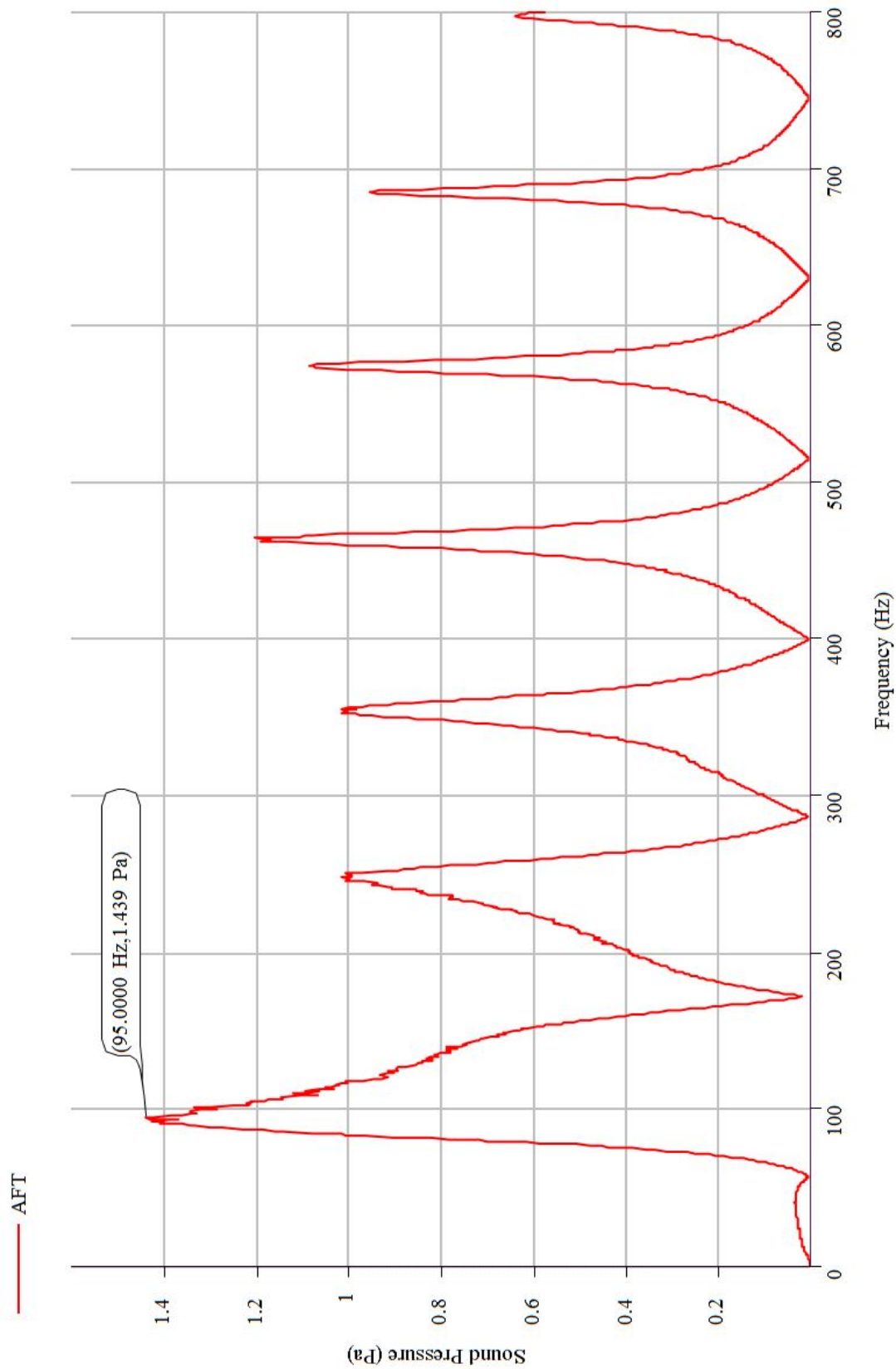

Figure 2.23: Mic AFT (Pa) Vs Frequency (Hz) (Aluminum Tube with Flat End Caps, Fixed-Translation Condition)

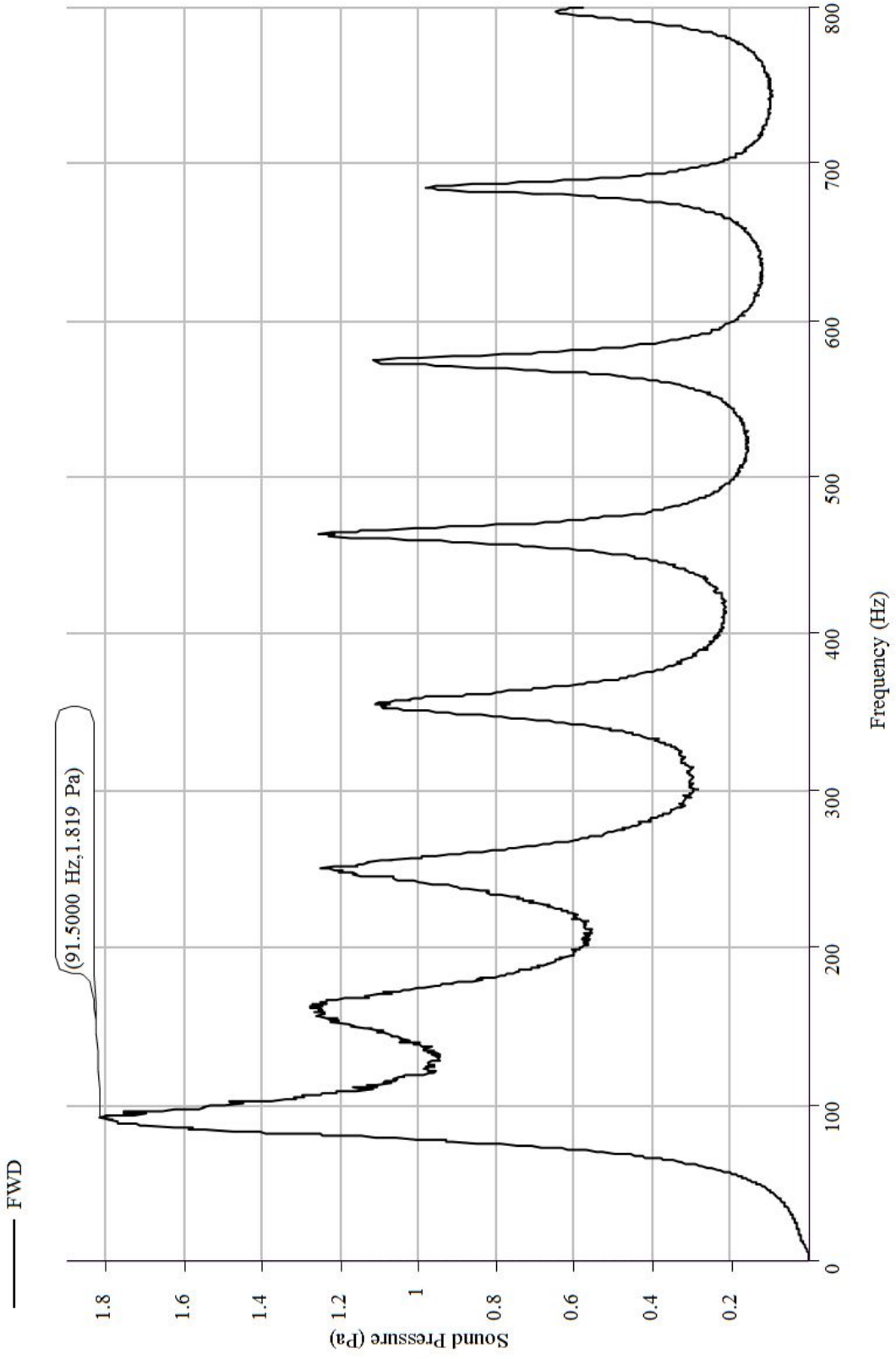

Figure 2.24: Mic FWD (Pa) Vs Frequency (Hz) (Aluminum Tube with Flat End Caps, Fixed-Translation Condition)

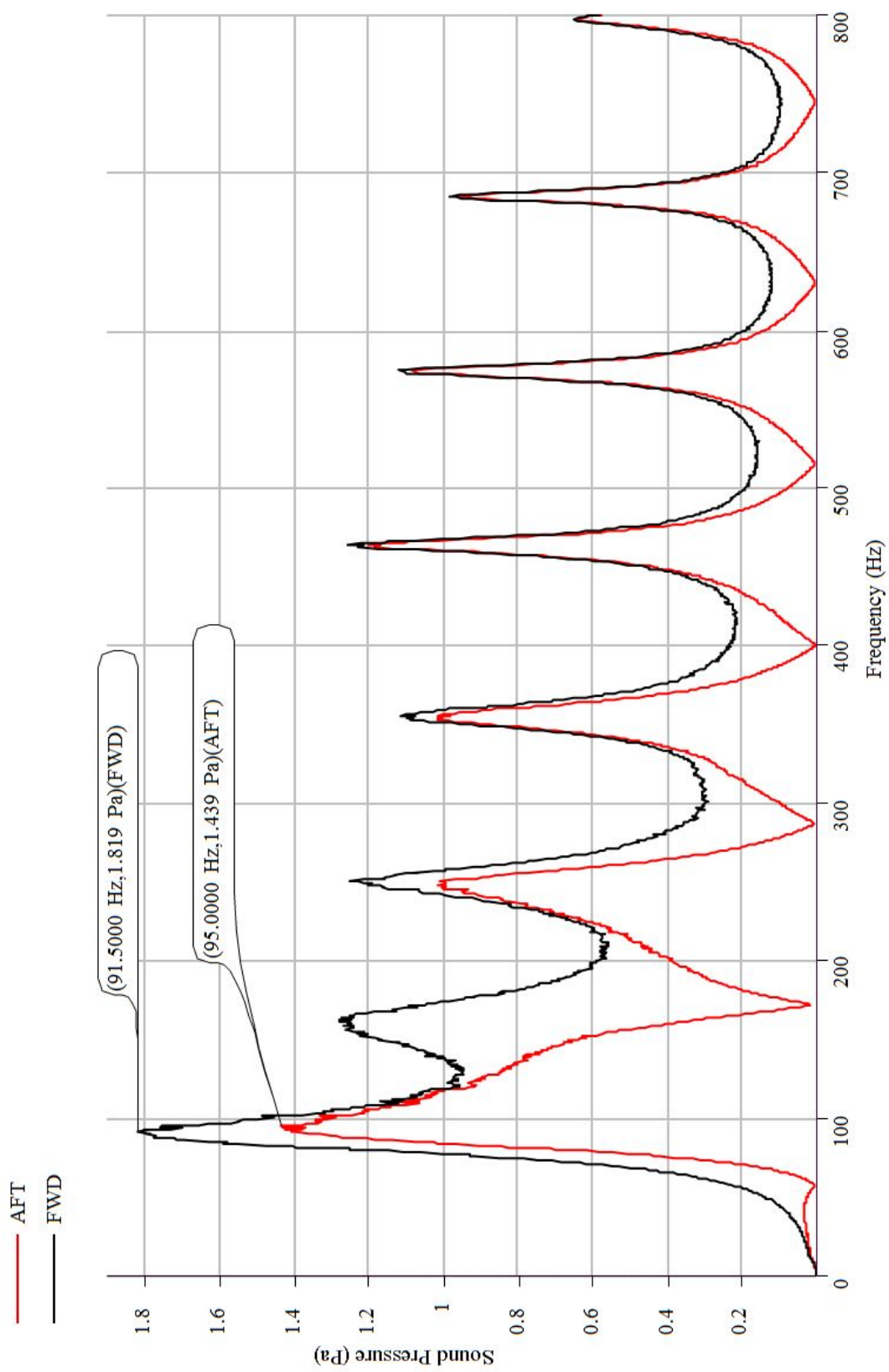

Figure 2.25: Sound Pressure (Pa) Vs Frequency (Hz) (Aluminum Tube with Flat End Caps, Fixed-Translation Condition)

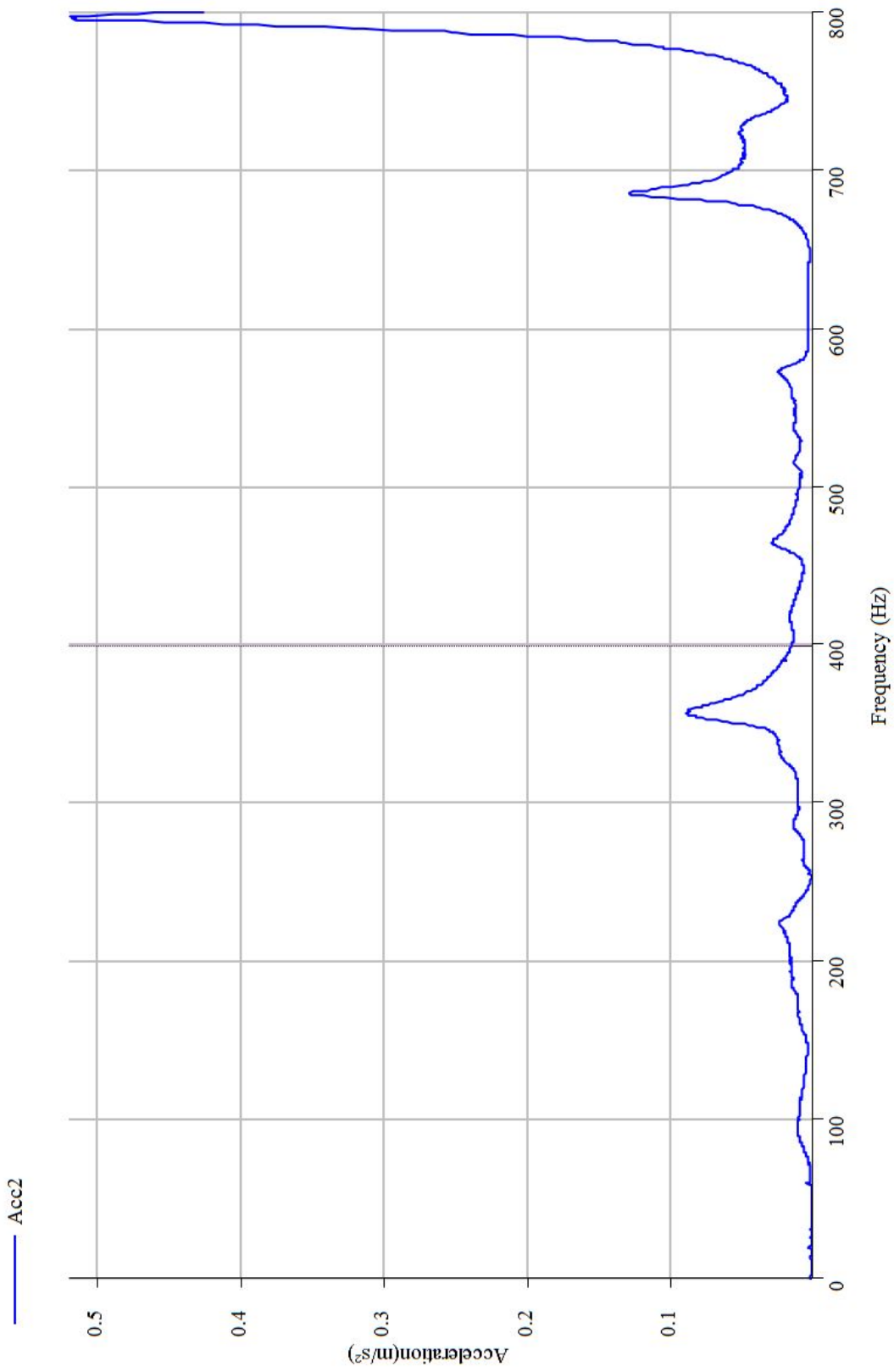

Figure 2.26: Acceleration (m/s^2) Vs Frequency (Hz) (Aluminum Tube with Flat End Caps, Fixed-Translation Condition)

Summary of Results

Table 2.3 shows the results for the aluminum tube with flat end caps (Fixed-Translation Condition) using acoustic excitation.

Aluminum Tube with Flat End Caps using Acoustic Excitation		
	Experimental Results	
	Sound Pressure Level(dB)	Sound Pressure (Pa)
Fixed-Translation Condition	97.14 dB at 95 Hz (Mic AFT)	1.439 Pa at 95 Hz (Mic AFT)
	99.17 dB at 91.5 Hz (Mic FWD)	1.819 Pa at 91.5 Hz (Mic FWD)

Table 2.3: Experimental Results for the Aluminum Tube with Flat End Caps (Fixed-Translation Condition) using Acoustic Excitation

2.2 Aluminum Tube with Dome End Cap Configuration

The three different boundary conditions applied at the ends of the aluminum tubes were:

- (i) Free-Free
- (ii) Fixed-Free
- (iii) Fixed-Translation

2.2.1 Free-Free Boundary Condition

Experimental Setup:

Tests were conducted on an aluminum circular cylindrical shell with the following material properties: Young's Modulus = 1×10^7 psi, Density = 0.1 lb/in^3 and Poisson's ratio = 0.33. The experimental setup for an aluminum tube with dome end caps for the free-free condition is shown in Figure 2.27



Figure 2.27: Free-Free Experimental Setup

A frequency range of 0-800 Hz was chosen for the frequency response measurements and a simple FFT analysis with a frequency resolution of 0.5 Hz averaged over 10,000 readings across the time domain was evaluated.

Results:

Figures 2.28 and 2.29 show the results for Sound level (dB) versus Frequency (Hz) for the AFT and FWD microphones, respectively, in the aluminum tube with dome end caps. The first peak was recorded at a sound level of 105.132 dB at 112.5 Hz for Mic AFT and 105.687 dB at 112.5 Hz for Mic FWD. Figure 2.30 is a composite of Figures 2.28 and 2.29 comparing the sound levels recorded at the AFT and FWD microphones.

Figures 2.31 and 2.32 show the results for Sound Pressure (Pa) versus Frequency (Hz) for the AFT and FWD microphones, respectively, in the aluminum tube with dome ends. The first peak pressure was recorded as 3.611 Pa at 112.5 Hz for Mic AFT and 3.849 Pa at 112.5 Hz for Mic FWD. Figure 2.33 is a composite of Figures 2.31 and 2.32 comparing the sound pressures recorded at the AFT and FWD microphones.

Figure 2.34 shows the Acceleration (m/s^2) versus Frequency (Hz) for the accelerometer placed at the FWD end in the aluminum tube with dome ends.

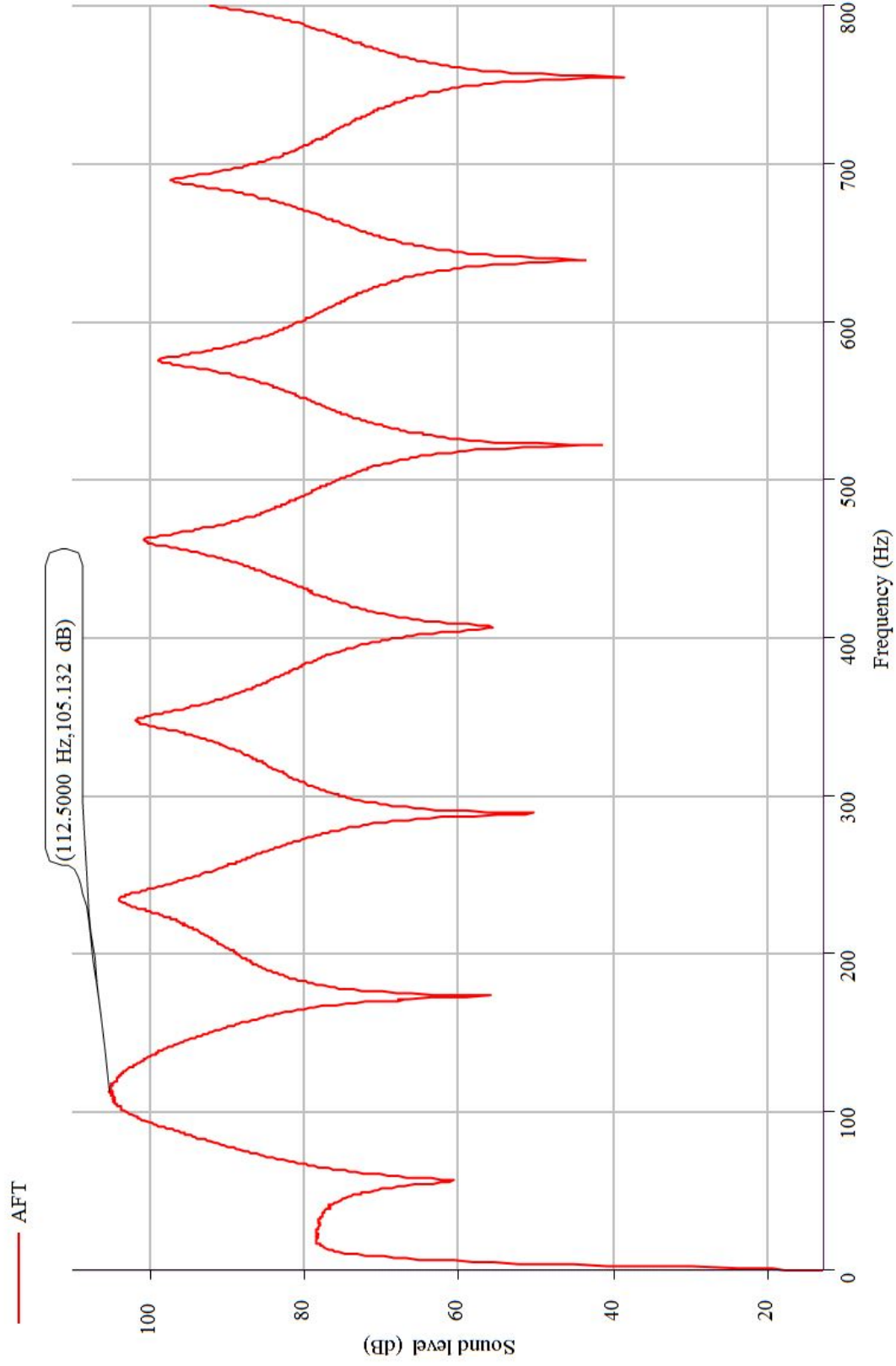

Figure 2.28: Mic AFT (dB) Vs Frequency (Hz) (Aluminum Tube with Dome End Caps, Free-Free Condition)

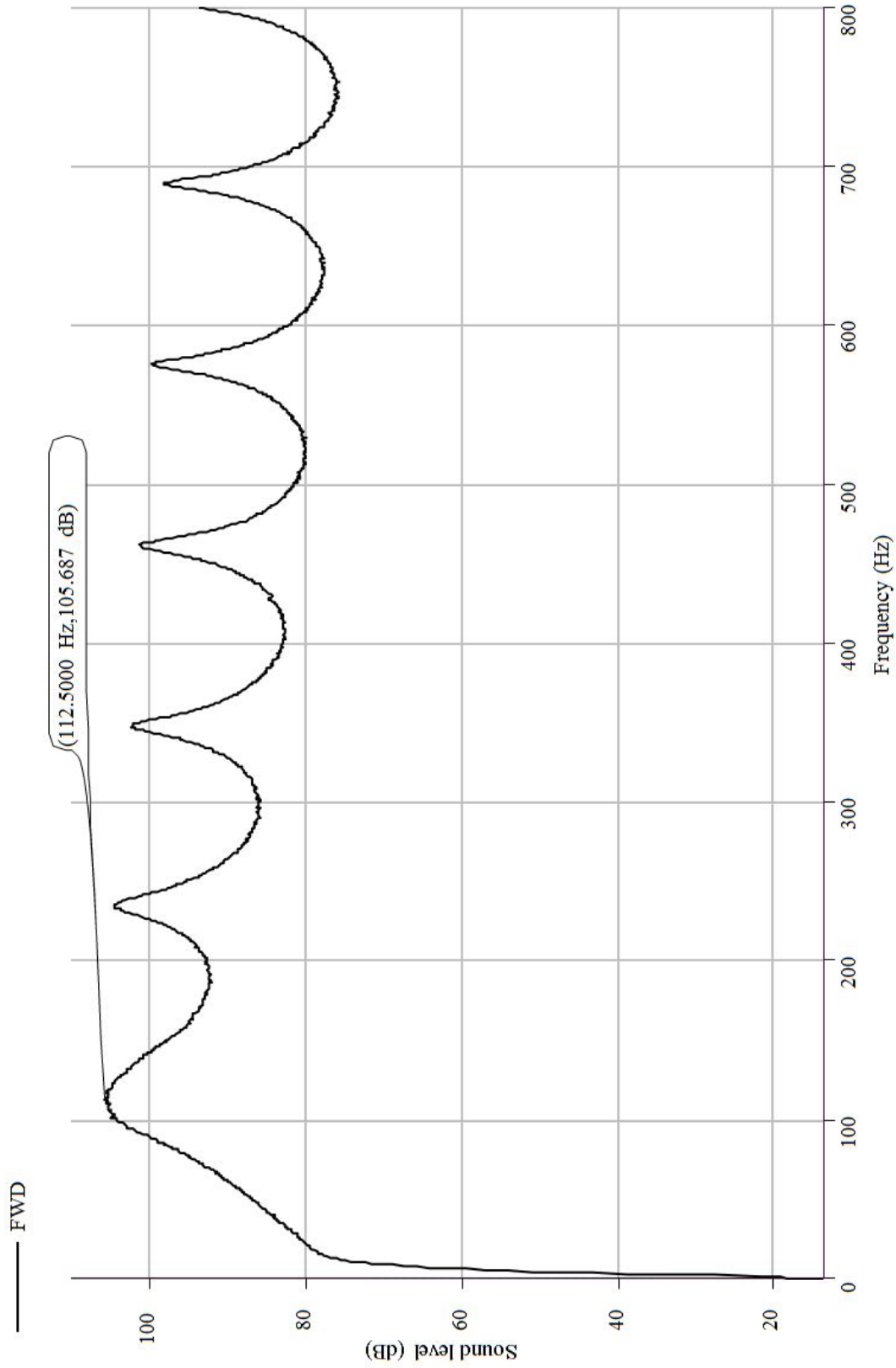

Figure 2:29: Mic FWD (dB) Vs Frequency (Hz) (Aluminum Tube with Dome End Caps, Free-Free Condition)

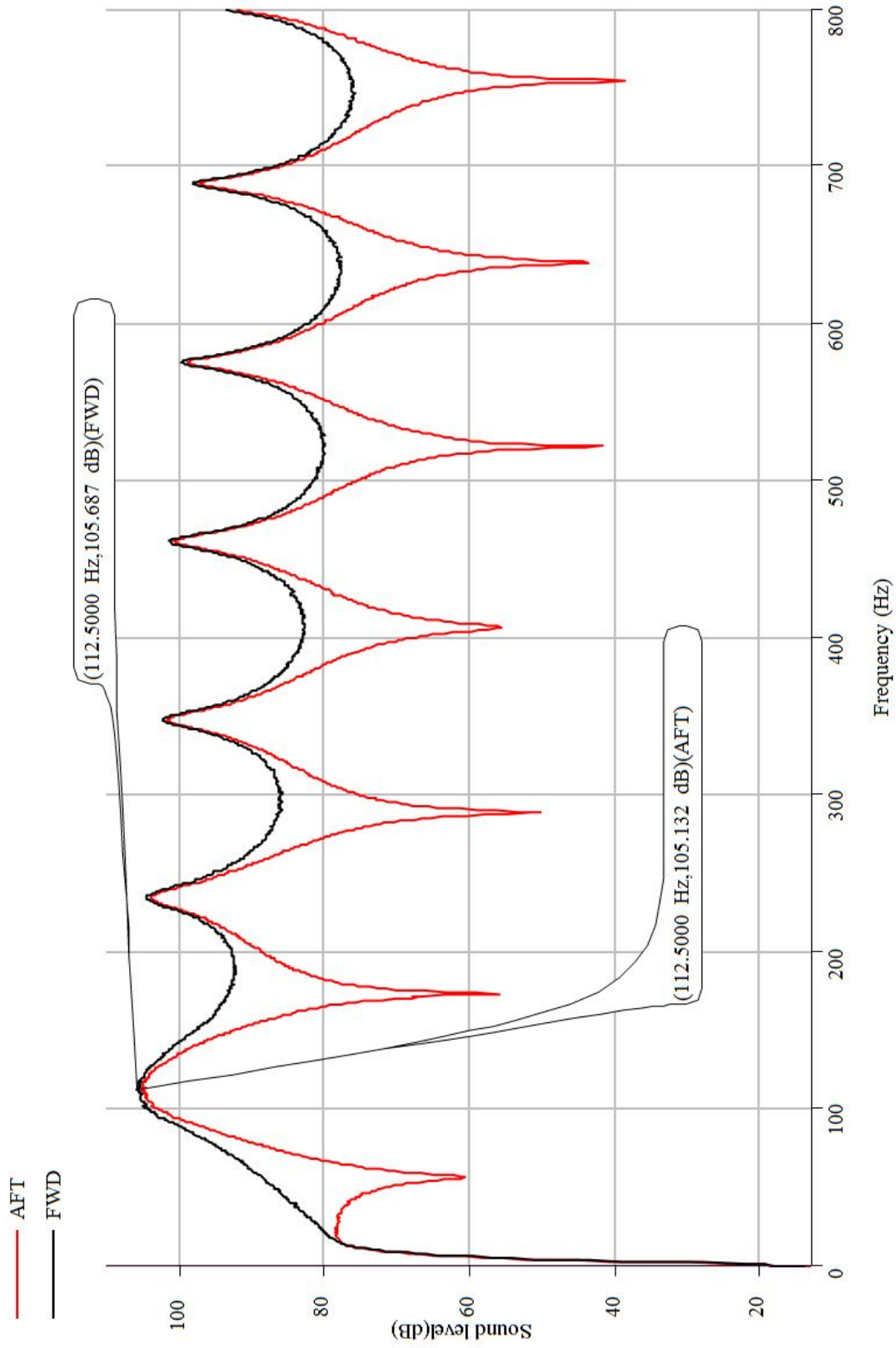

Figure 2.30: Sound Pressure Level (dB) Vs Frequency (Hz) (Aluminum Tube with Dome End Caps, Free-Free Condition)

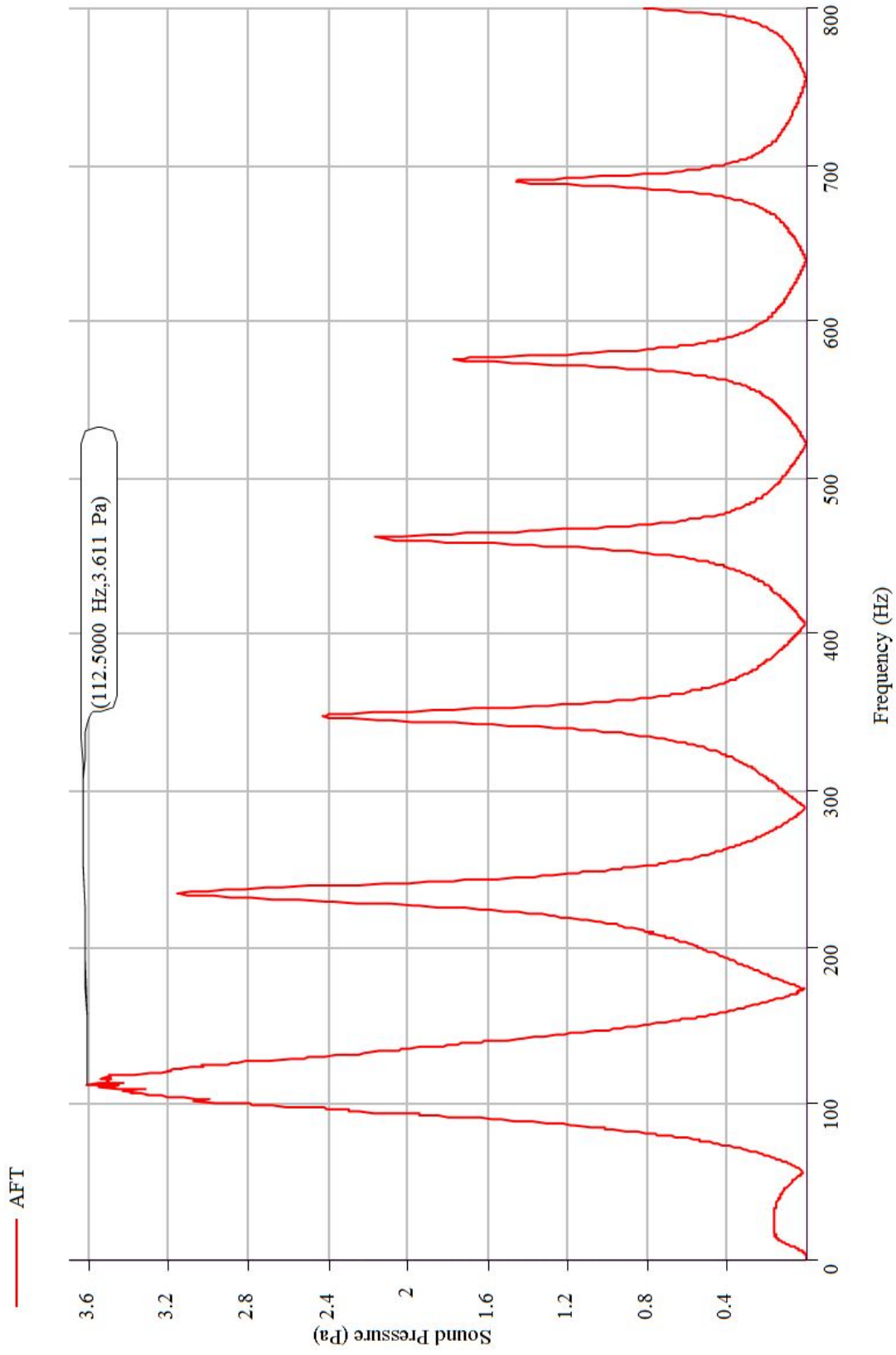

Figure 2.31: Mic AFT (Pa) Vs Frequency (Hz) (Aluminum Tube with Dome End Caps, Free-Free Condition)

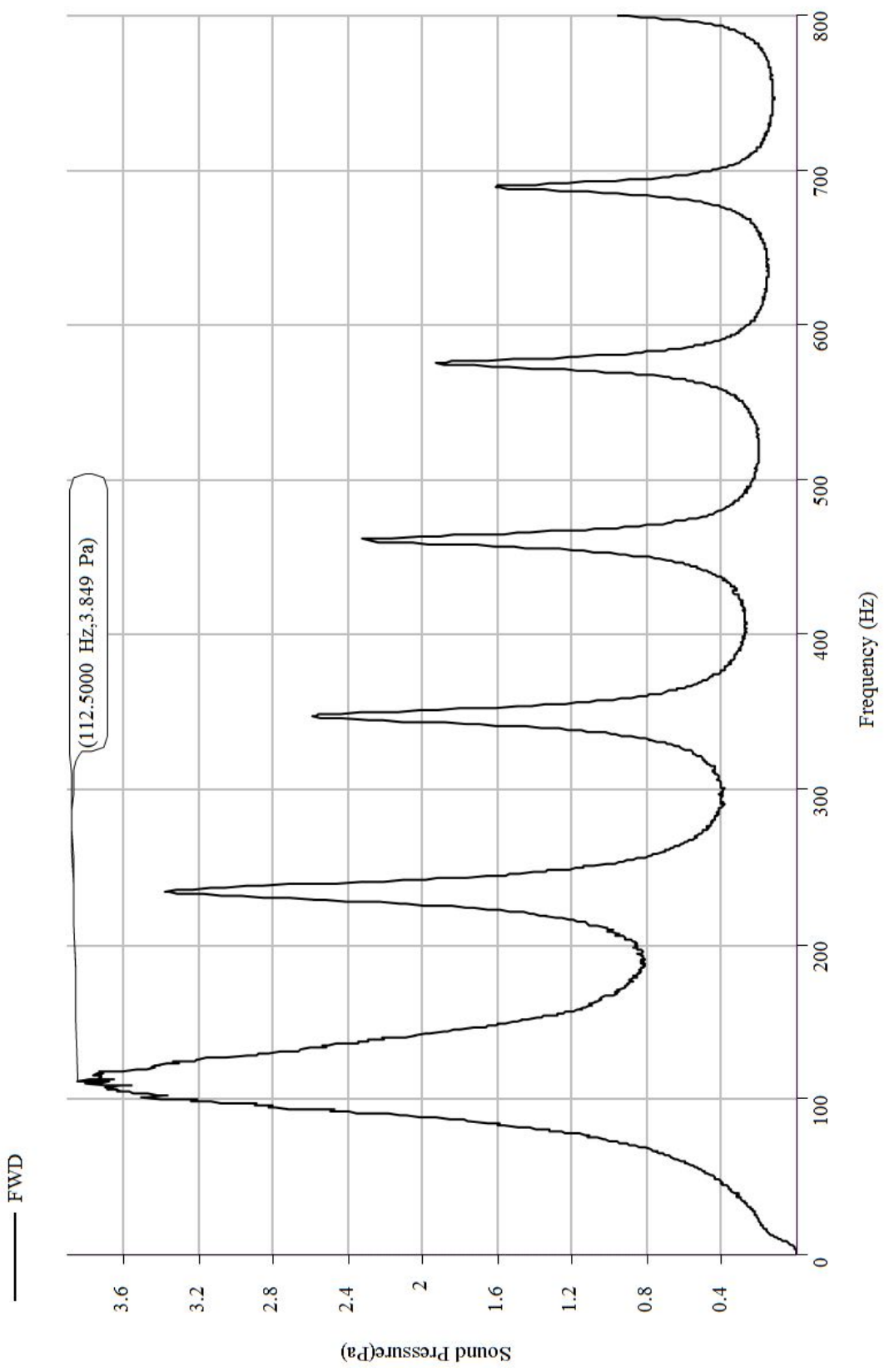

Figure 2.32: Mic FWD (Pa) Vs Frequency (Hz) (Aluminum Tube with Dome End Caps, Free-Free Condition)

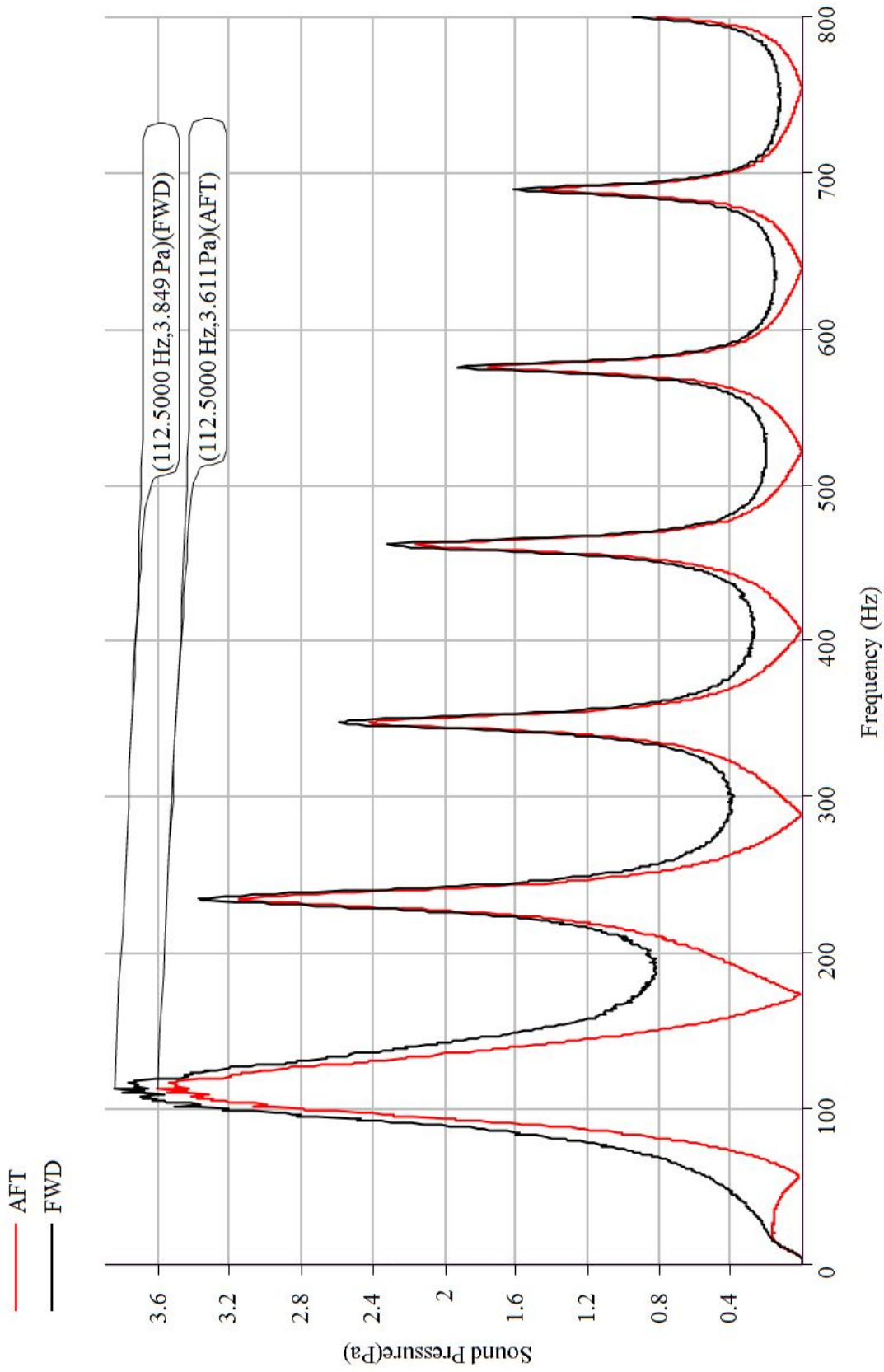

Figure 2.33: Sound Pressure (Pa) Vs Frequency (Hz) (Aluminum Tube with Dome End Caps, Free-Free Condition)

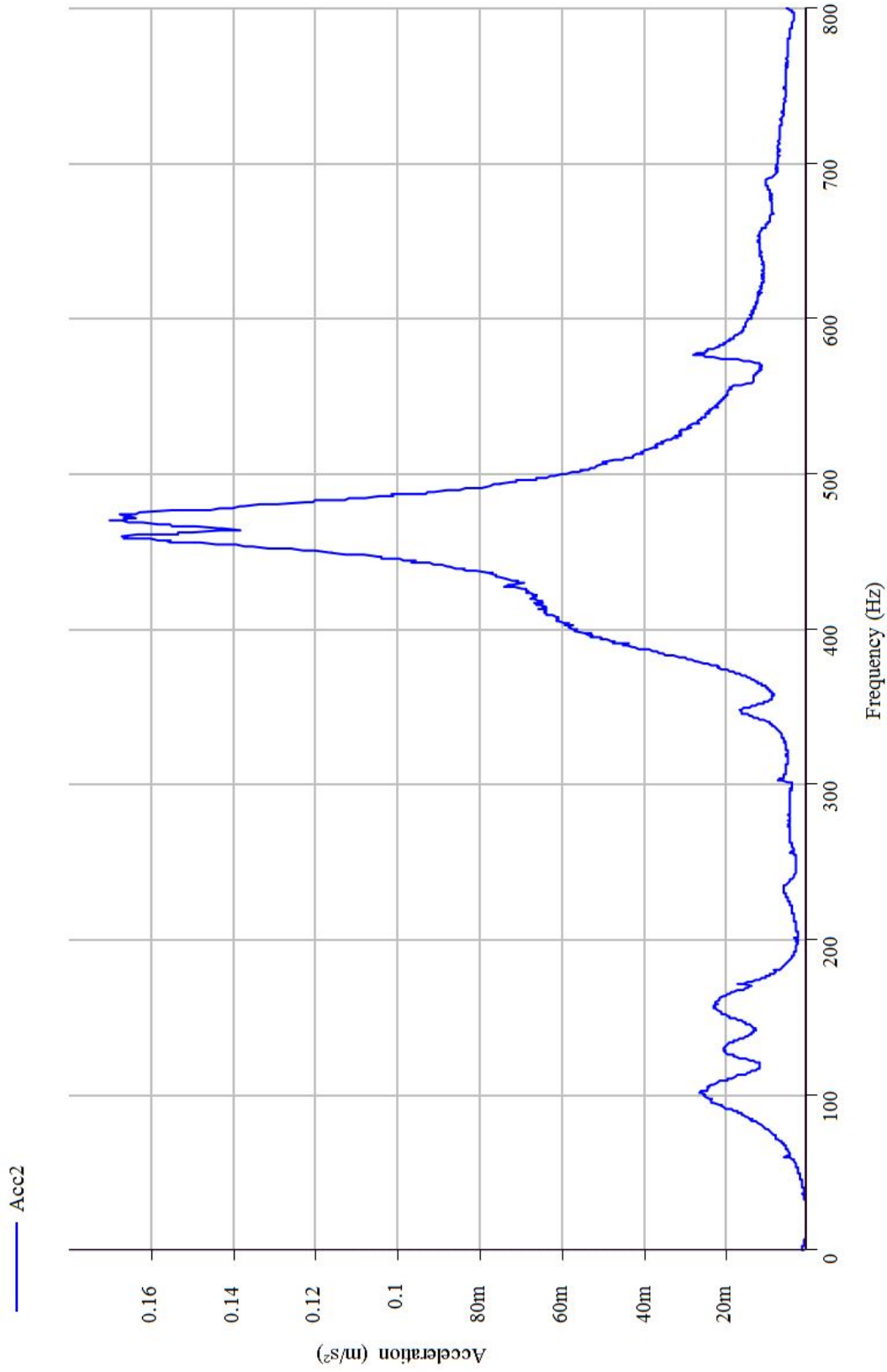

Figure 2.34: Acceleration (m/s^2) Vs Frequency (Hz) (Aluminum Tube with Dome End Caps, Free-Free Condition)

Summary of Results

Table 2.4 shows the results for the aluminum tube with dome end caps (Free-Free Condition) using acoustic excitation.

Aluminum Tube with Dome End Caps using Acoustic Excitation		
	Experimental Results	
	Sound Pressure Level(dB)	Sound Pressure (Pa)
Free-Free Condition	105.132 dB at 112.5 Hz (Mic AFT)	3.611 Pa at 112.5 Hz (Mic AFT)
	105.687 dB at 112.5 Hz (Mic FWD)	3.849 Pa at 112.5 Hz (Mic FWD)

Table 2.4: Experimental Results of Aluminum Tube with Dome End Caps (Free-Free Condition) using Acoustic Excitation

2.2.2 Fixed-Free Boundary Condition

Experimental Setup:

The experimental setup for an aluminum tube with dome end caps for the fixed-free condition is shown in Figure 2.35



Figure 2.35: Fixed-Free Experimental Setup

Results:

Figures 2.36 and 2.37 show the results for Sound Level (dB) versus Frequency (Hz) for the AFT and FWD microphones, respectively, in the aluminum tube with dome end caps. The first peak was recorded at a sound level of 105.160 dB at 112.50 Hz for Mic AFT and 105.712 dB at 112.50 Hz for Mic FWD. Figure 2.38 is a composite of Figures 2.36 and 2.37 comparing the sound levels recorded at the AFT and FWD microphones.

Figures 2.39 and 2.40 show the results for Sound Pressure (Pa) versus Frequency (Hz) for the AFT and FWD microphones, respectively, in the aluminum tube with dome end caps.

The first peak pressure was recorded as 3.623 Pa at 112.50 Hz for Mic AFT and 3.860 Pa at 112.50 Hz for Mic FWD. Figure 2.41 is a composite of Figures 2.39 and 2.40 comparing the sound pressures recorded at the AFT and FWD microphones.

Figure 2.42 shows the Acceleration (m/s^2) versus Frequency (Hz) for the accelerometer placed at the FWD end of the aluminum tube with dome end caps.

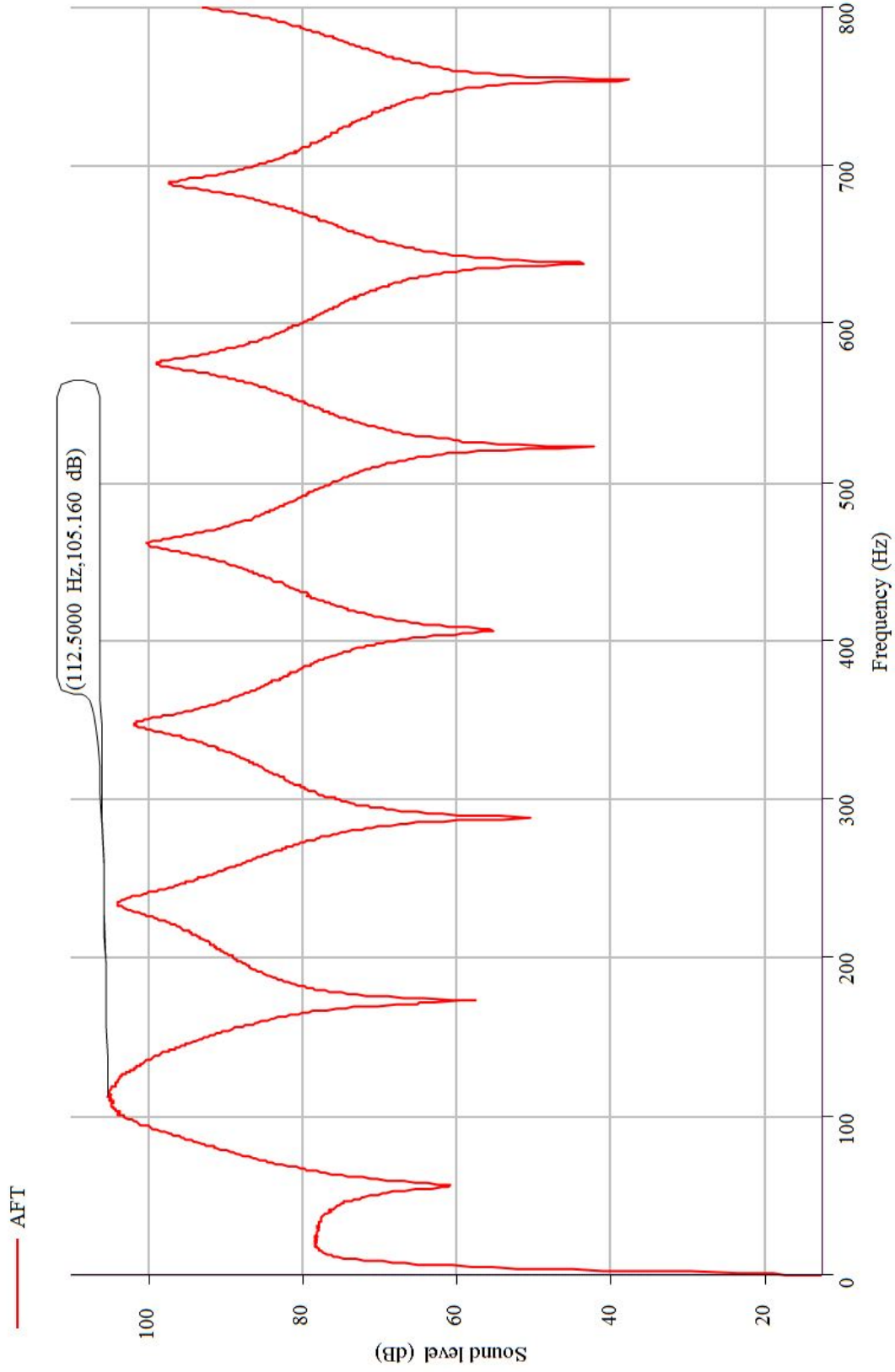

Figure 2.36: Mic AFT (dB) Vs Frequency (Hz) (Aluminum Tube with Dome End Caps, Fixed-Free Condition)

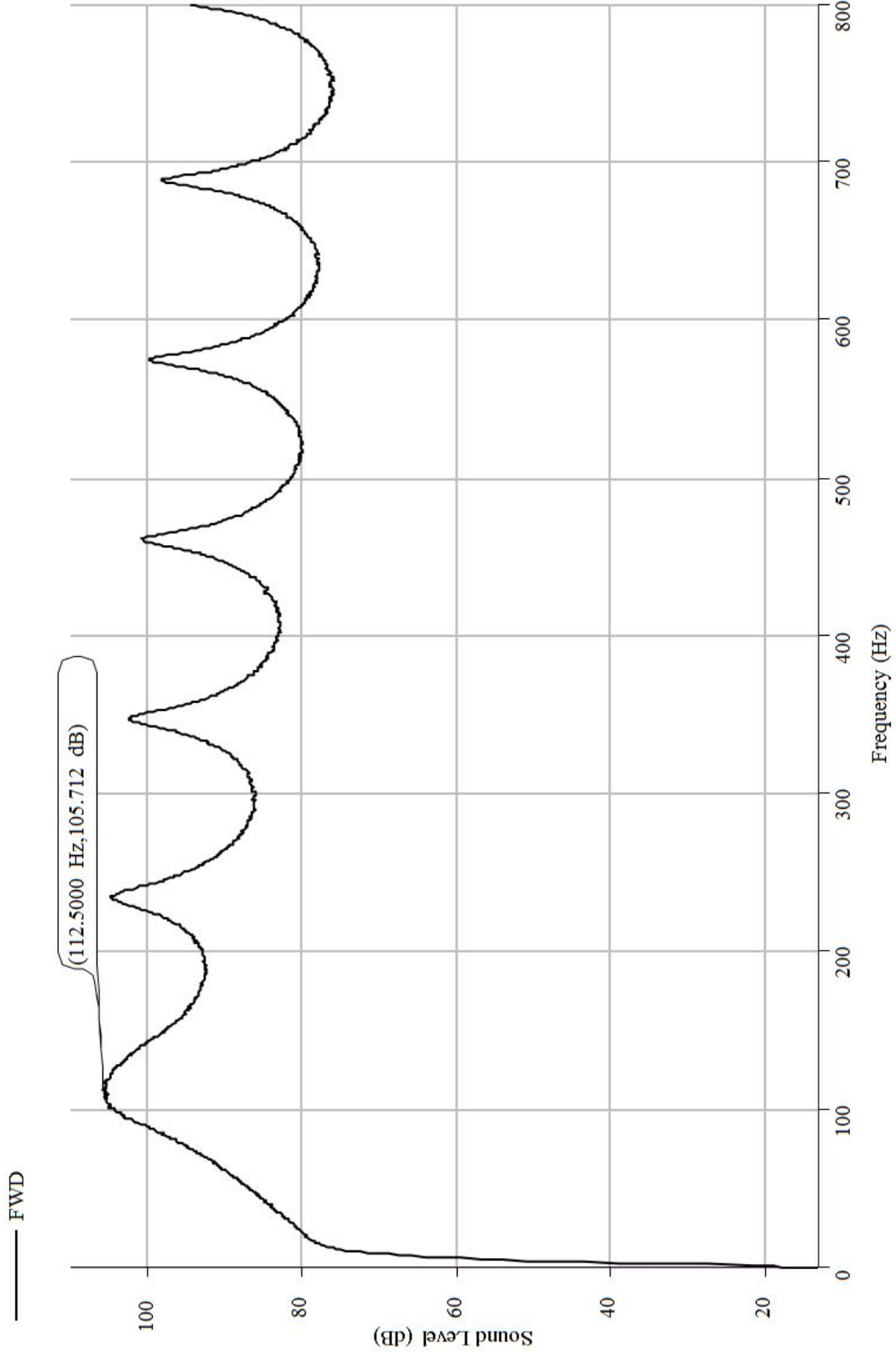

Figure 2.37: Mic FWD (dB) Vs Frequency (Hz) (Aluminum Tube with Dome End Caps, Fixed-Free Condition)

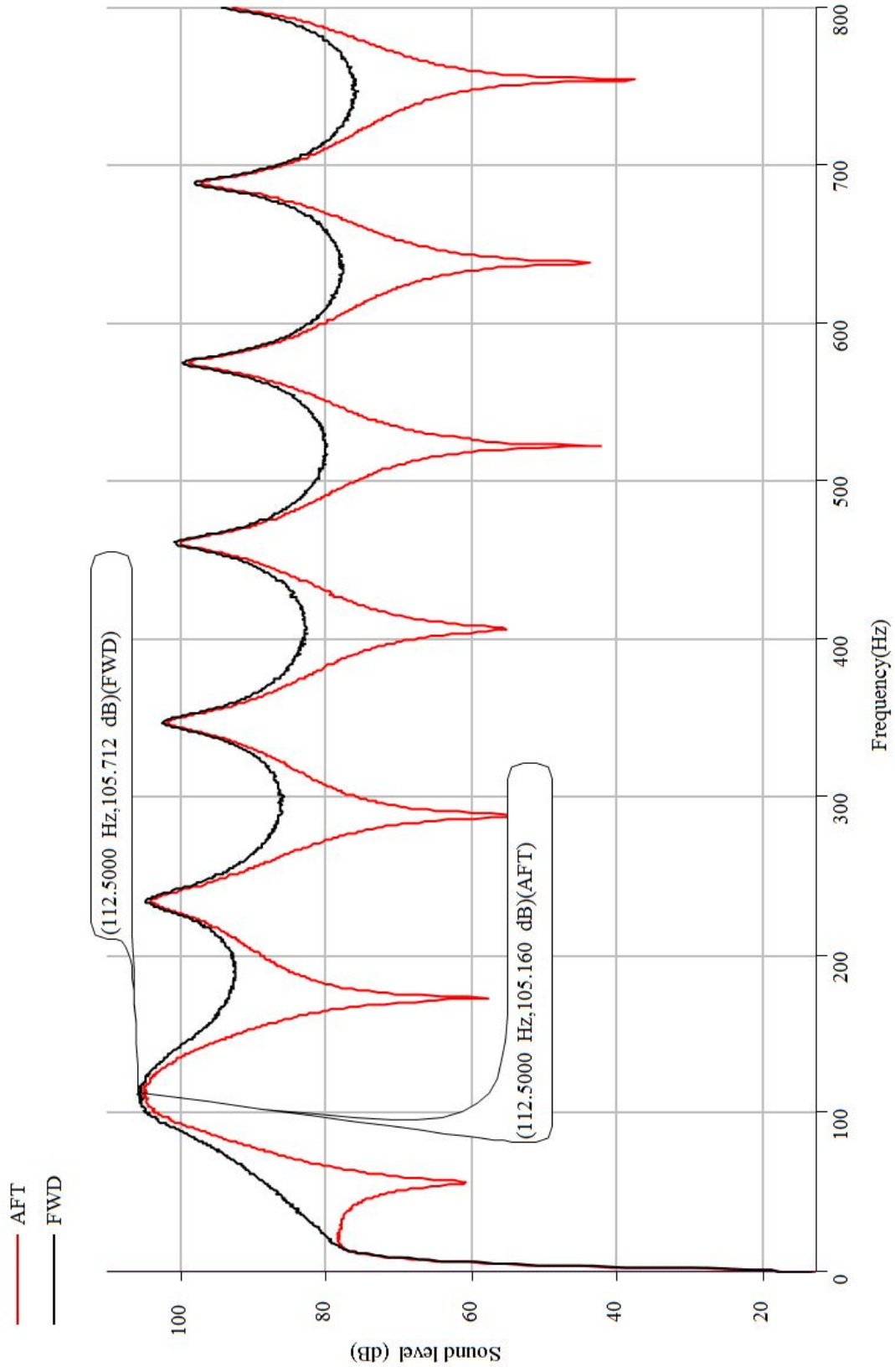

Figure 2.38: Sound Pressure Level (dB) Vs Frequency (Hz) (Aluminum Tube with Dome End Caps, Fixed-Free Condition)

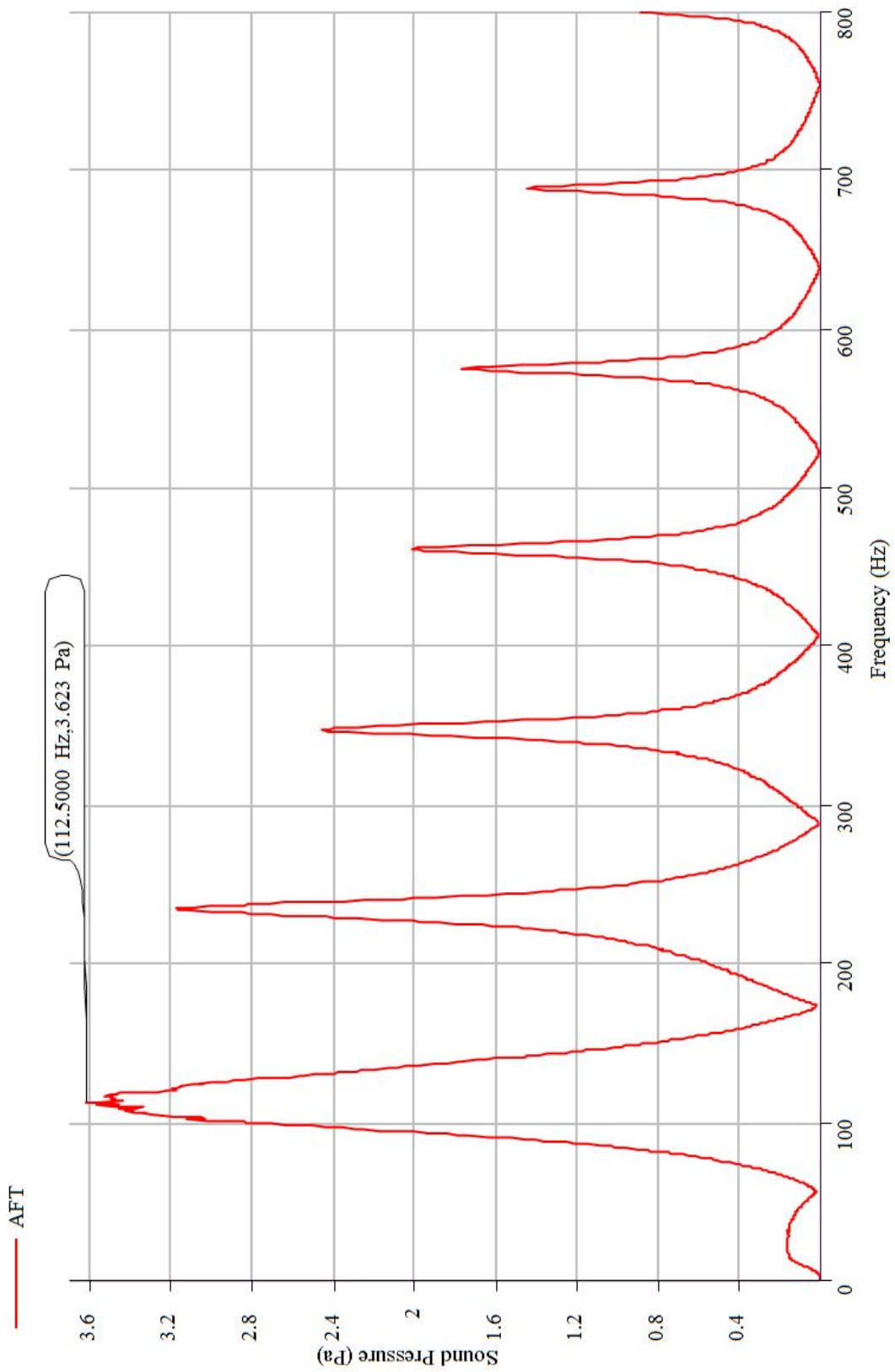

Figure 2-39: Mic AFT (Pa) Vs Frequency (Hz) (Aluminum Tube with Dome End Caps, Fixed-Free Condition)

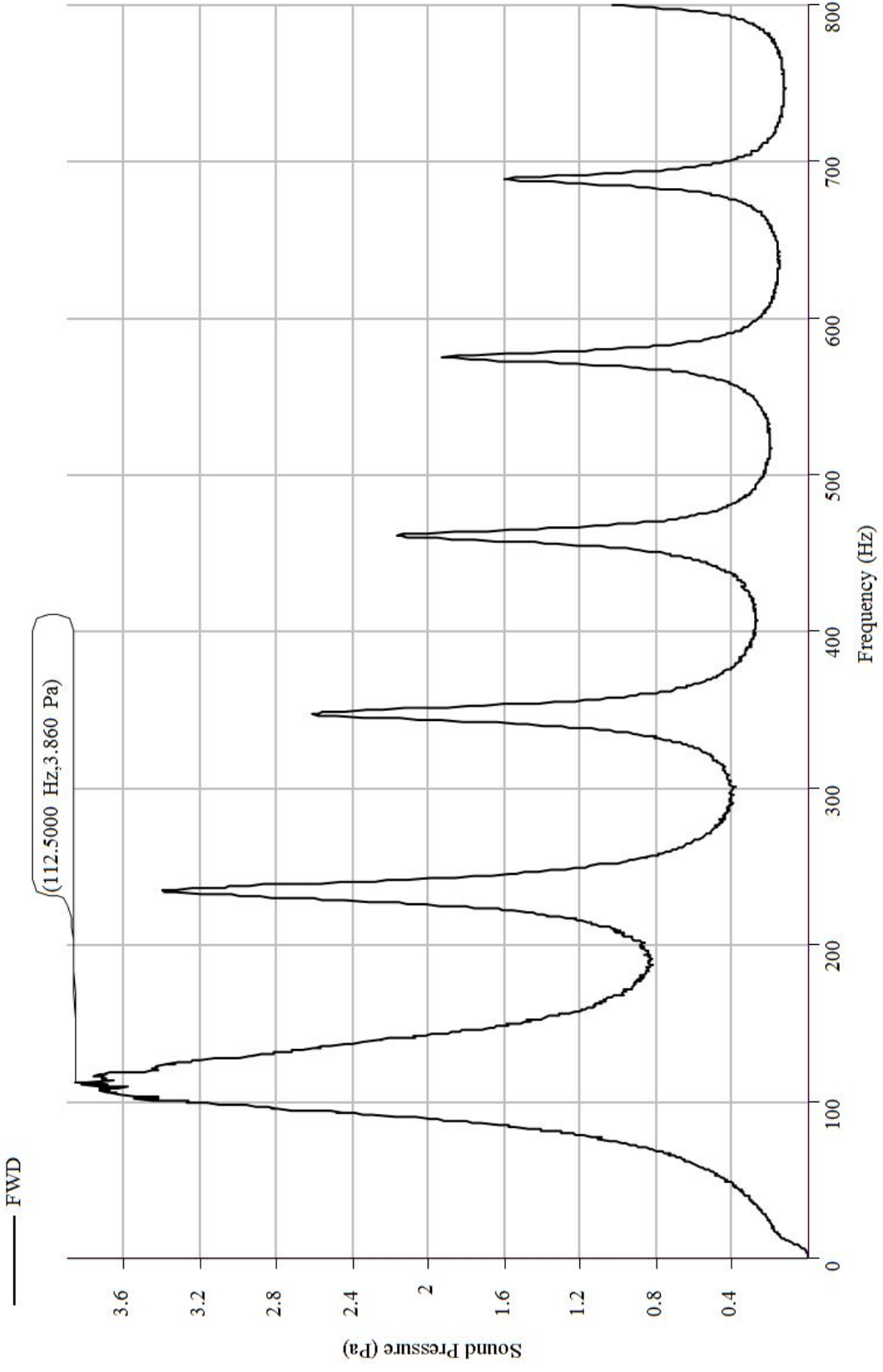

Figure 2.40: Mic FWD (Pa) Vs Frequency (Hz) (Aluminum Tube with Dome End Caps, Fixed- Free Condition)

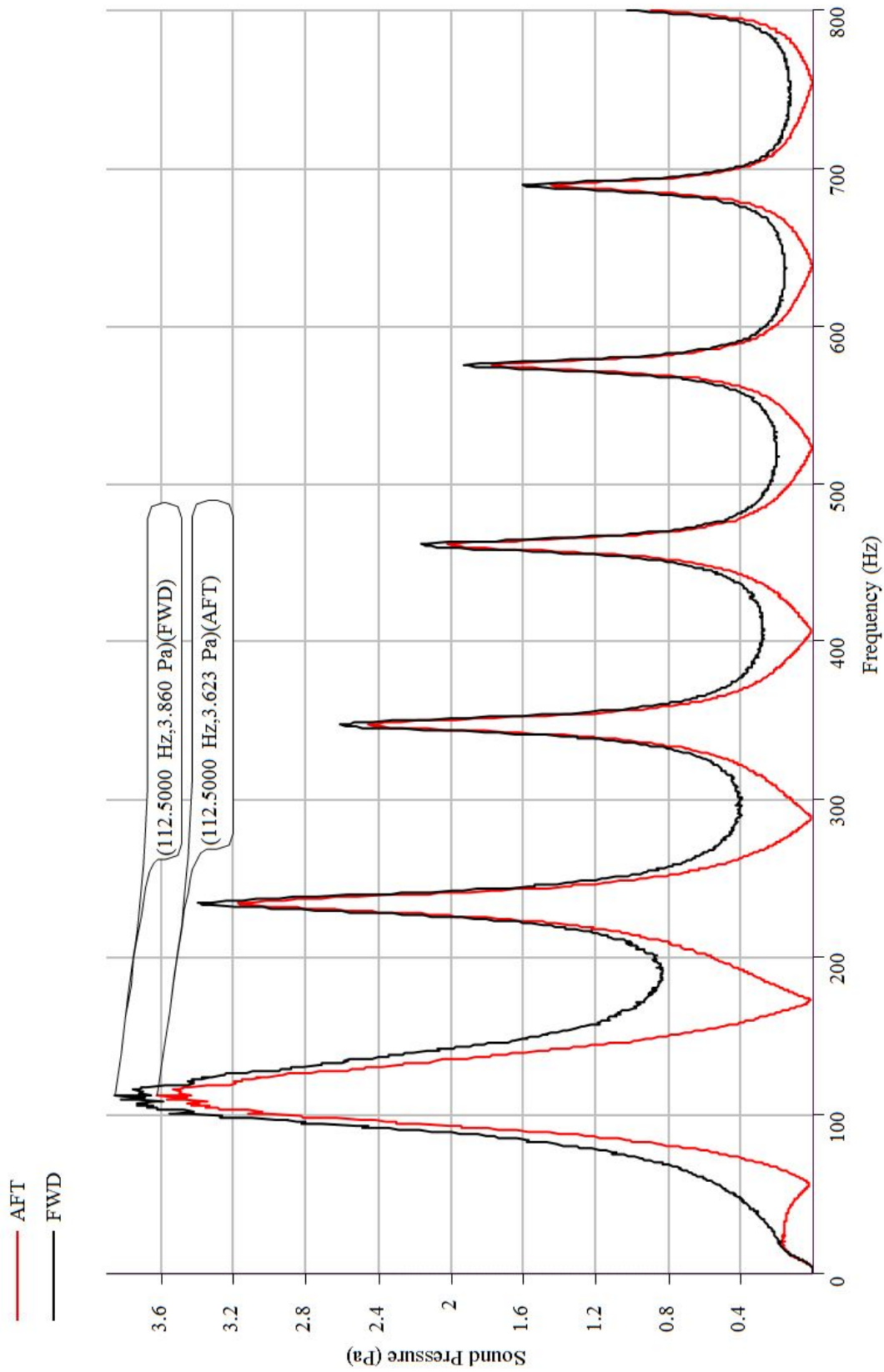

Figure 2.41: Sound Pressure (Pa) Vs Frequency (Hz) (Aluminum Tube with Dome End Caps, Fixed- Free Condition)

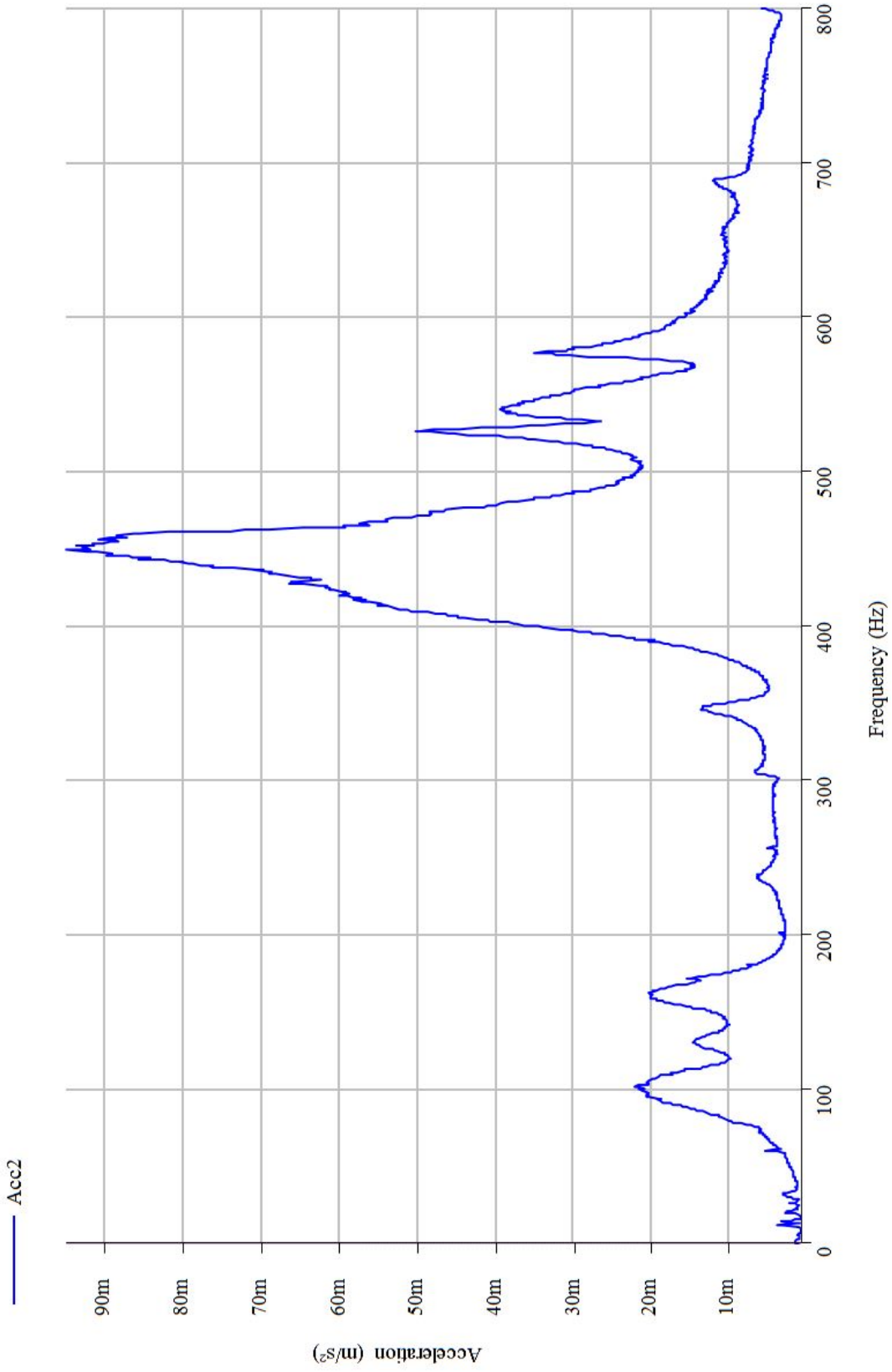

Figure 2.42: Acceleration (m/s^2) Vs Frequency (Hz) (Aluminum Tube with Dome End Caps, Fixed- Free Condition)

Summary of Results

Table 2.5 shows the results for the aluminum tube with dome end caps (Fixed-Free Condition) using acoustic excitation.

Aluminum Tube with Dome End Caps using Acoustic Excitation		
	Experimental Results	
	Sound Pressure Level(dB)	Sound Pressure (Pa)
Fixed-Free Condition	105.160 dB at 112.5 Hz (Mic AFT)	3.623 Pa at 112.5 Hz (Mic AFT)
	105.712 dB at 112.5 Hz (Mic FWD)	3.860 Pa at 112.5 Hz (Mic FWD)

Table 2.5: Experimental Results of Aluminum Tube with Dome End Caps (Fixed-Free Condition) using Acoustic Excitation

2.2.3 Fixed-Translation Boundary Condition

Experimental Setup:

The experimental setup for an aluminum tube with dome end caps in the fixed-translation condition is shown in Figure 2.43



Figure 2.43: Fixed-Translation Experimental Setup

Results:

Figures 2.44 and 2.45 show the results for Sound Level (dB) versus Frequency (Hz) for the AFT and FWD microphones, respectively, in the aluminum tube with dome end caps. The first peak was recorded at a sound level of 105.144 dB at 112.50 Hz for Mic AFT and 105.697 dB at 112.50 Hz for Mic FWD. Figure 2.46 is a composite of Figures 2.44 and 2.45 comparing the sound levels recorded at the AFT and FWD microphones.

Figures 2.47 and 2.48 show the results for Sound Pressure (Pa) versus Frequency(Hz) for the AFT and FWD microphones, respectively, in the aluminum tube with dome ends. The first peak pressure was recorded as 3.616 Pa at 112.50 Hz for Mic AFT and 3.854 Pa at

112.50 Hz for Mic FWD. Figure 2.49 is a composite of figures 2.47 and 2.48 comparing the sound pressures recorded at the AFT and FWD microphones.

Figure 2.50 shows the Acceleration (m/s^2) versus Frequency (Hz) for the accelerometer placed at the FWD end of the aluminum tube with dome end caps.

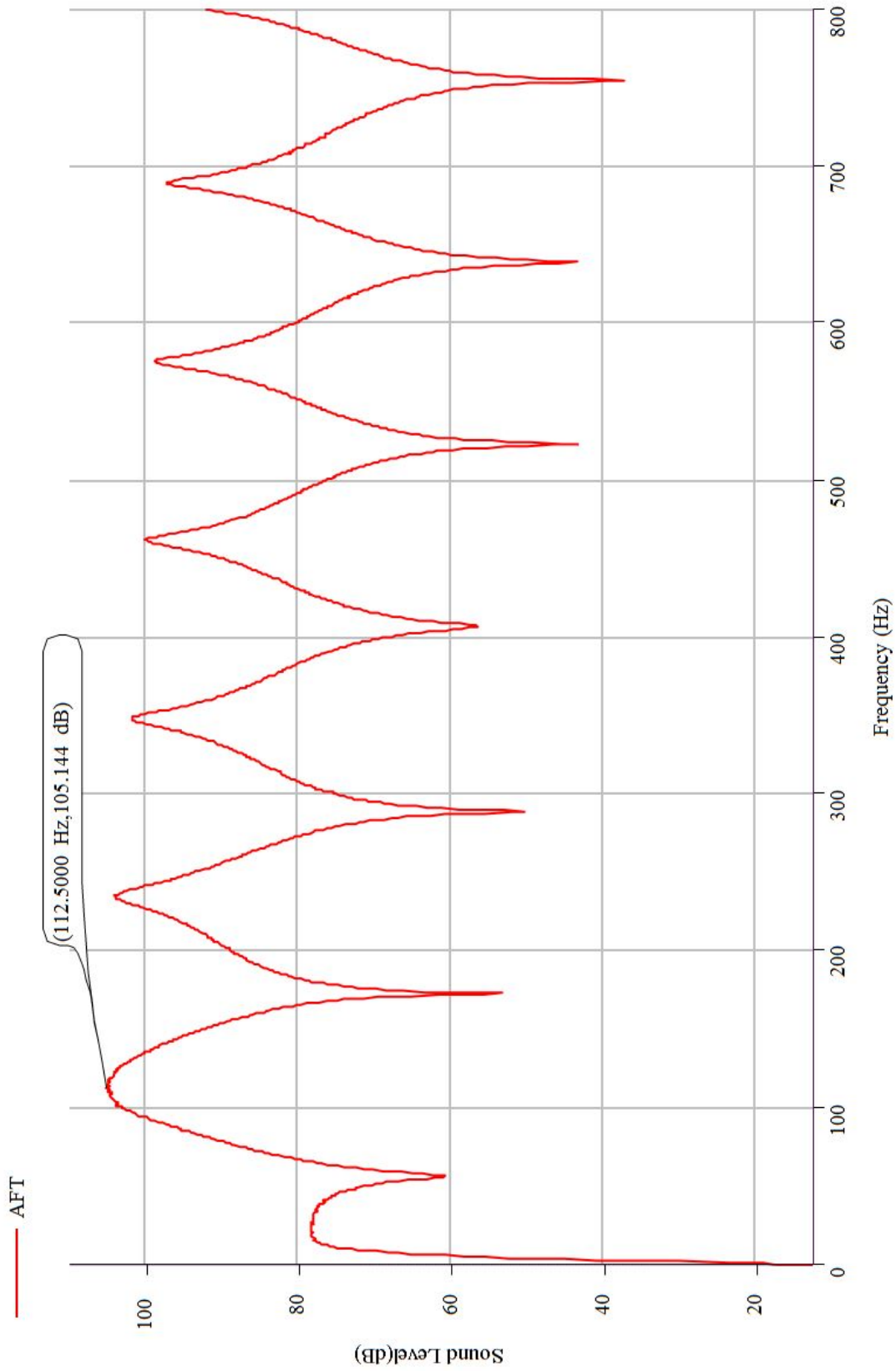

Figure 2.44: Mic AFT (dB) Vs Frequency (Hz) (Aluminum Tube with Dome Ends, Fixed-Translation Condition)

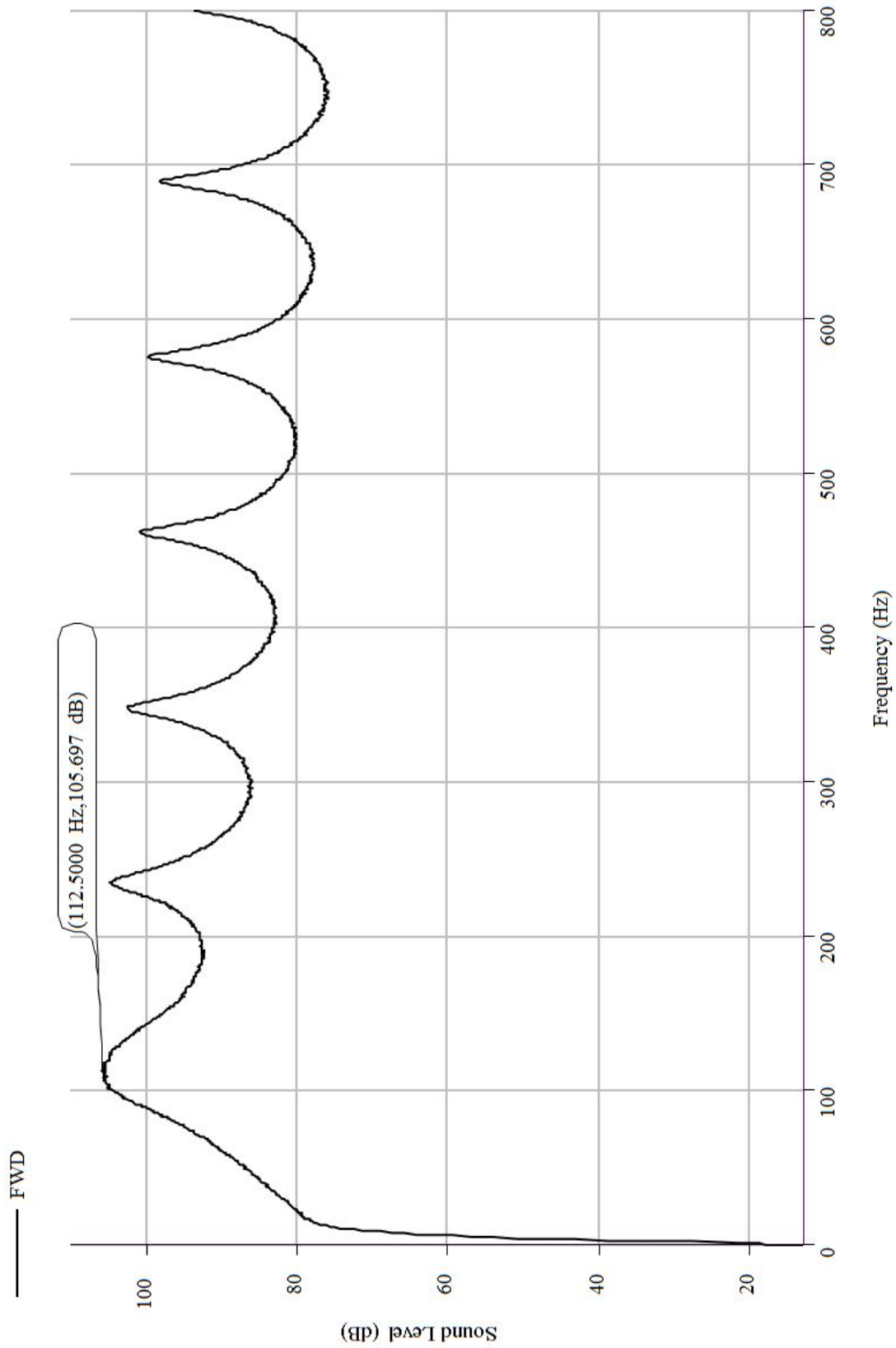

Figure 2.45: Mic FWD (dB) Vs Frequency (Hz) (Aluminum Tube with Dome Ends, Fixed-Translation Condition)

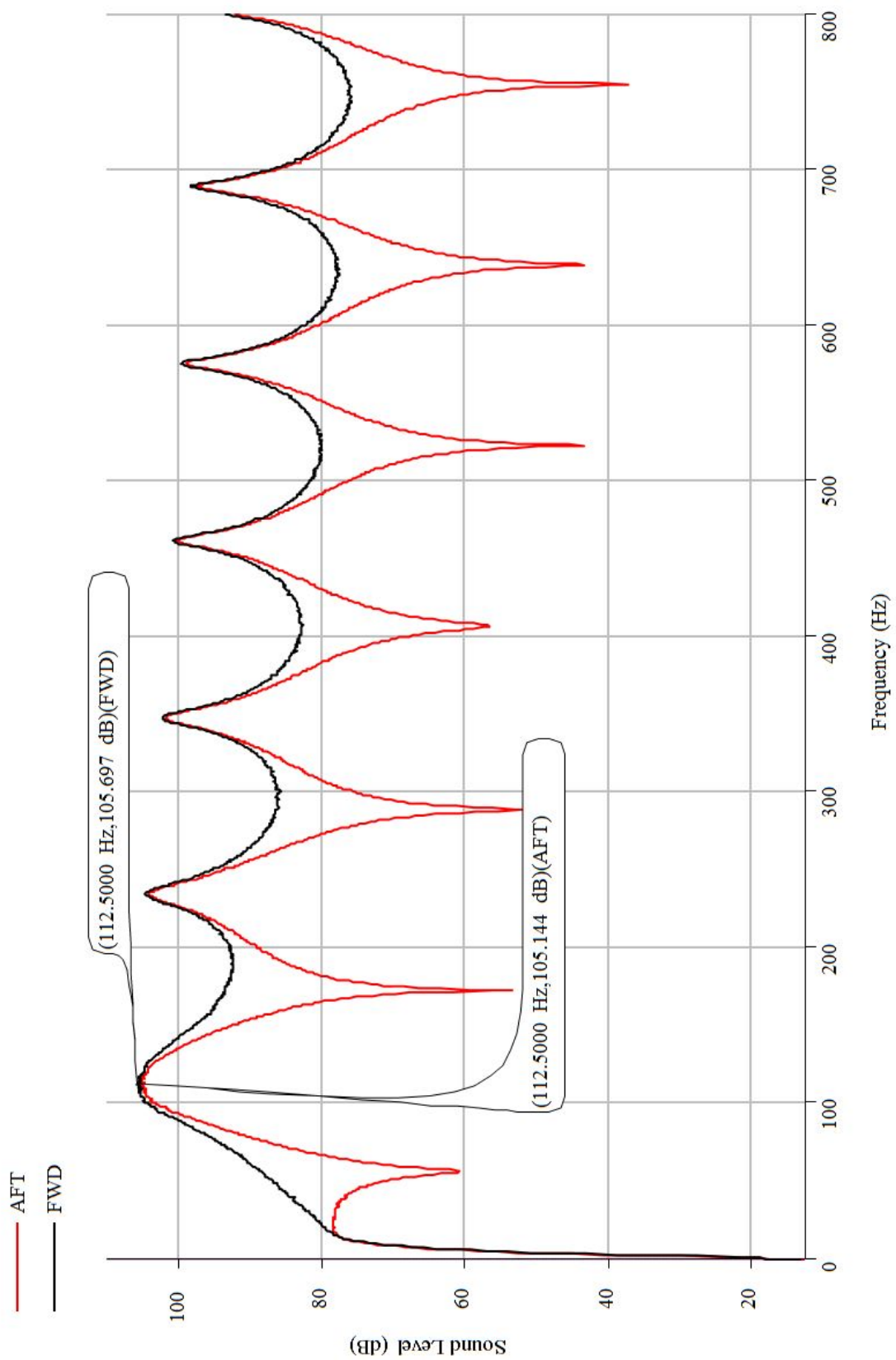

Figure 2.46: Sound Pressure Level (dB) Vs Frequency (Hz) (Aluminum Tube with Dome Ends, Fixed-Translation Condition)

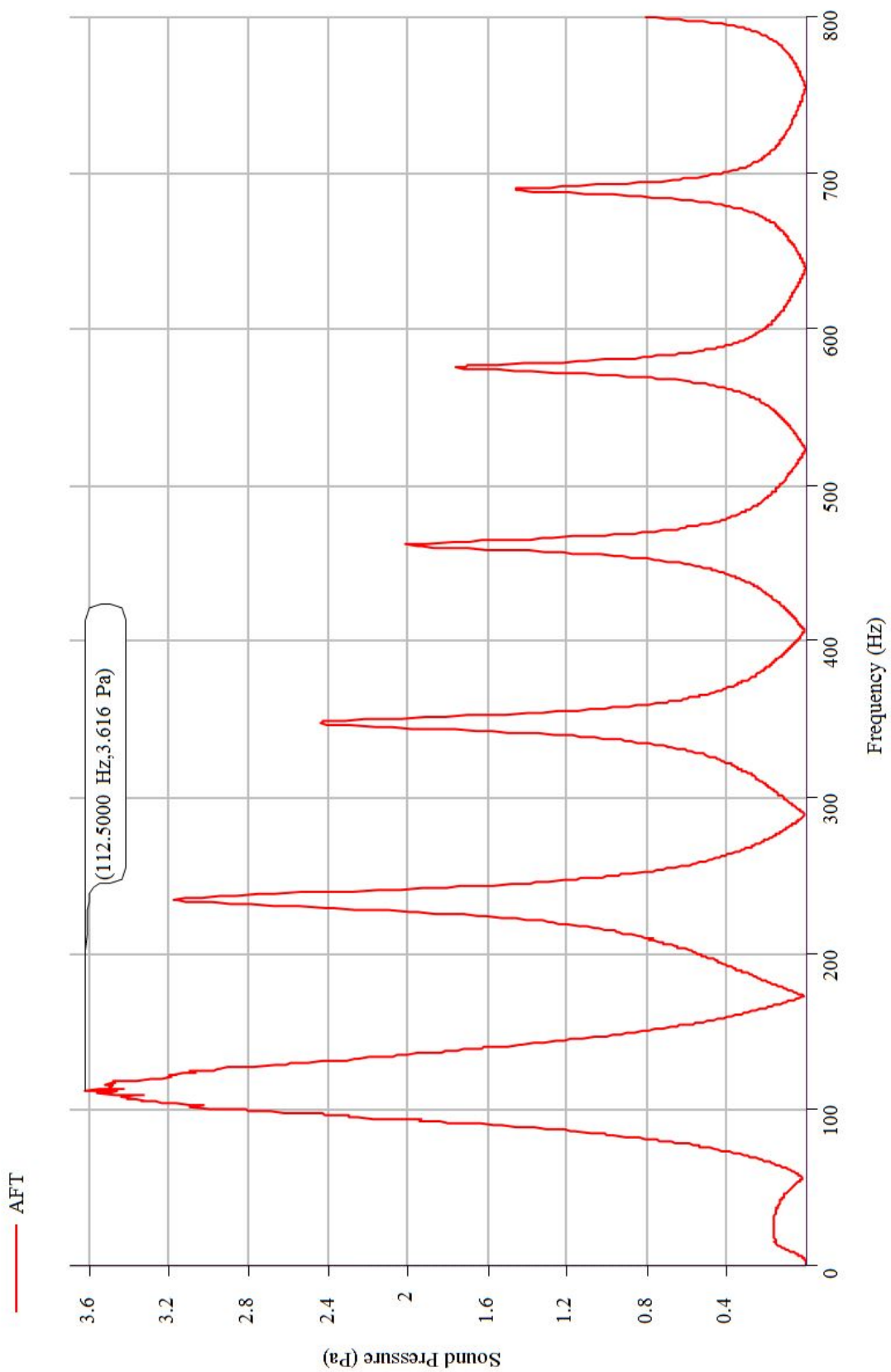

Figure 2.47: Mic AFT (Pa) Vs Frequency (Hz) (Aluminum Tube with Dome Ends, Fixed-Translation Condition)

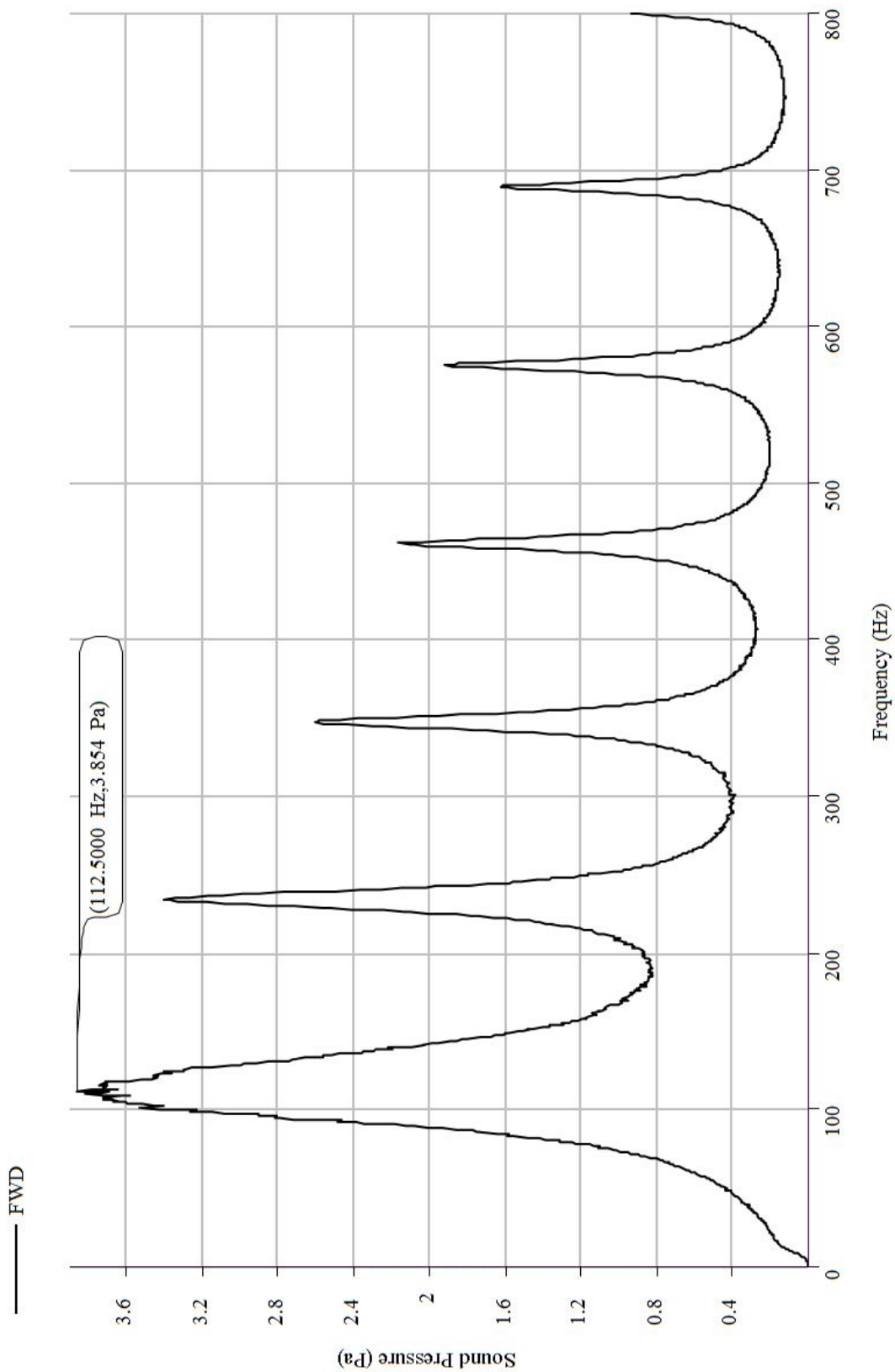

Figure 2.48: Mic FWD (Pa) Vs Frequency (Hz) (Aluminum Tube with Dome Ends, Fixed-Translation Condition)

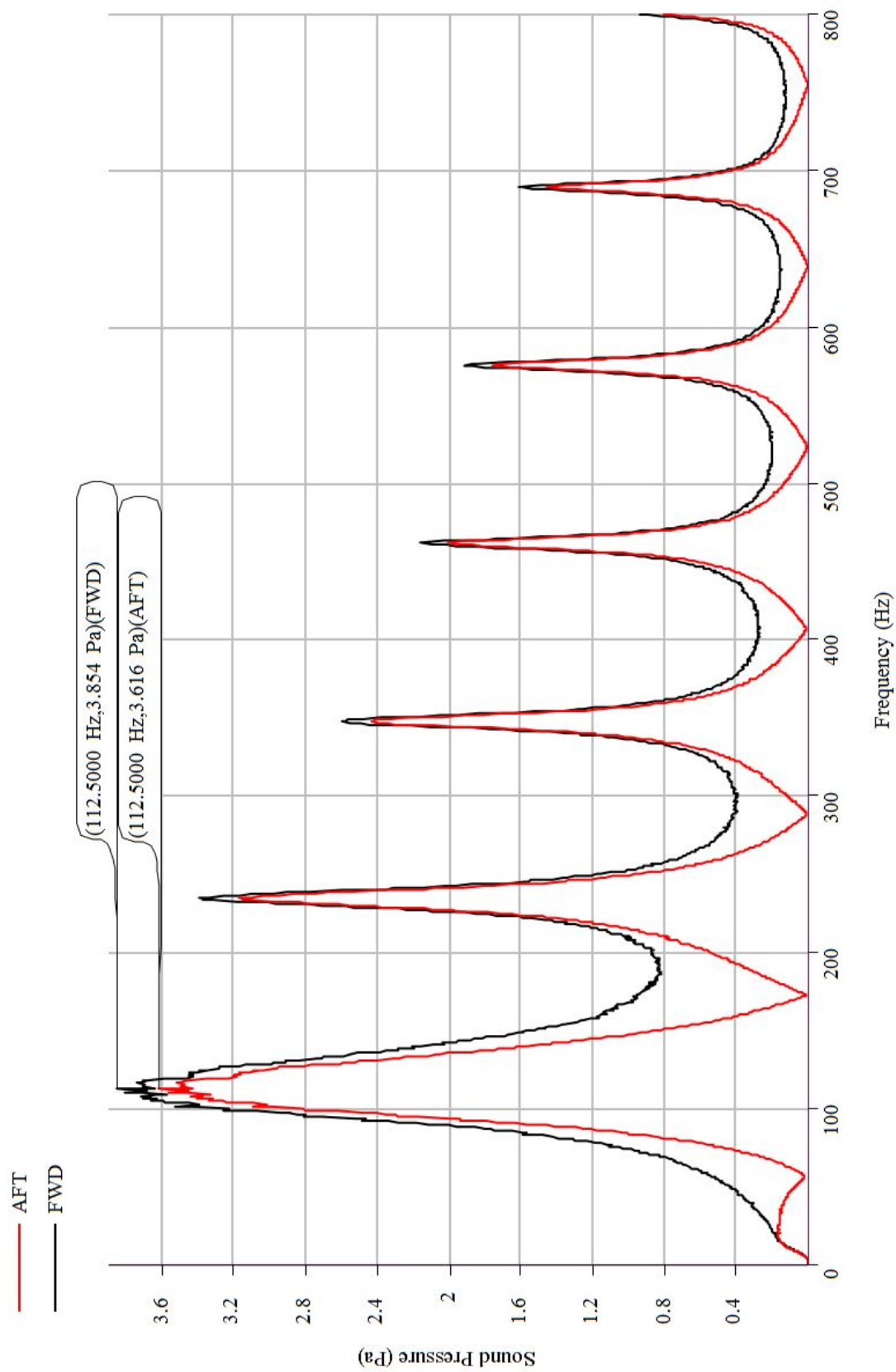

Figure 2.49: Sound Pressure (Pa) Vs Frequency (Hz) (Aluminum Tube with Dome Ends, Fixed-Translation Condition)

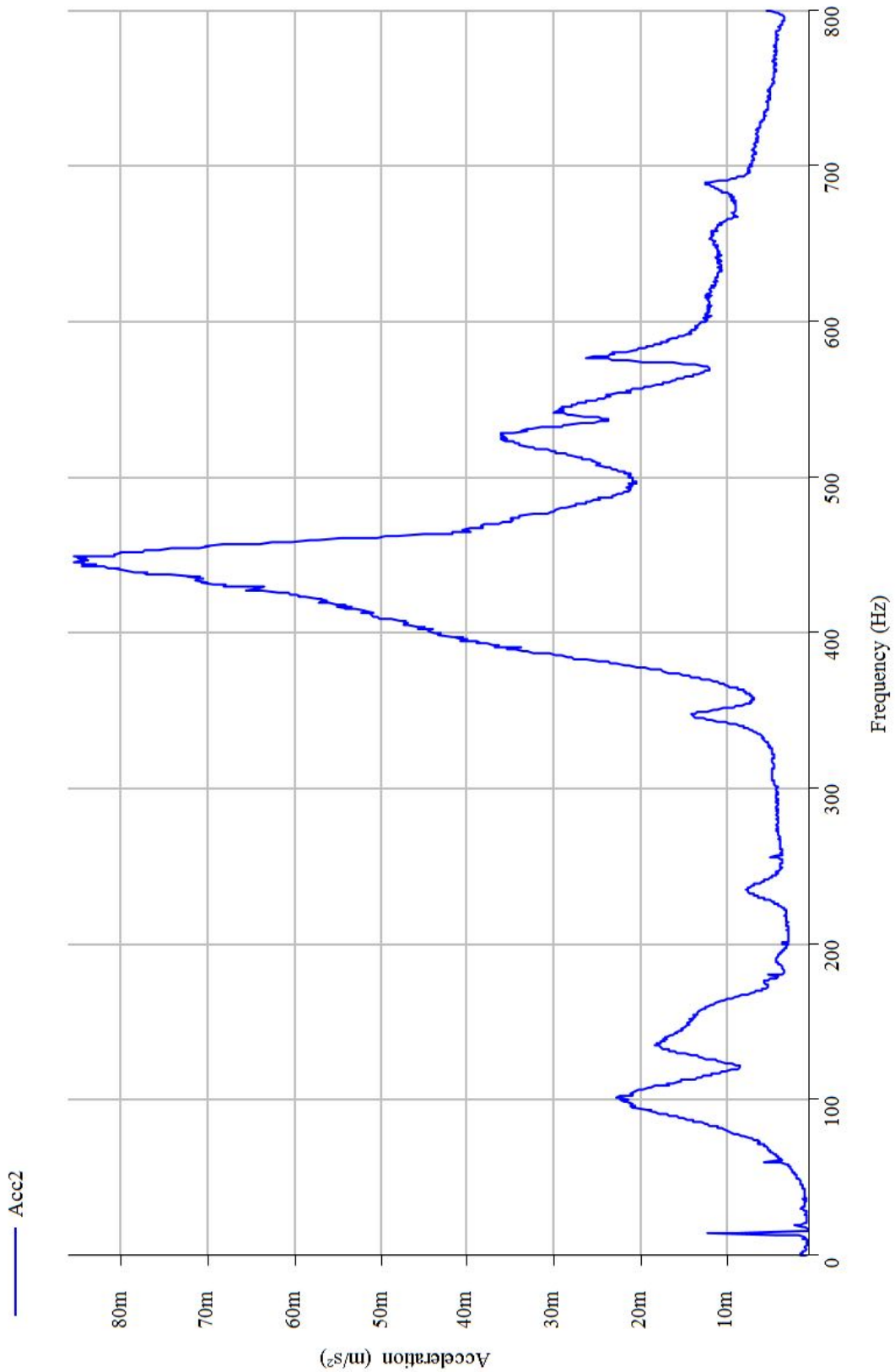

Figure 2.50: Acceleration (m/s^2) Vs Frequency (Hz) (Aluminum Tube with Dome Ends, Fixed-Translation Condition)

Summary of Results

Table 2.6 shows the results for the aluminum tube with dome end caps (Fixed-Translation Condition) using acoustic excitation.

Aluminum Tube with Dome End Caps using Acoustic Excitation		
	Experimental Results	
	Sound Pressure Level(dB)	Sound Pressure (Pa)
Fixed-Translation Condition	105.144 dB at 112.5 Hz (Mic AFT)	3.616 Pa at 112.5 Hz (Mic AFT)
	105.697 dB at 112.5 Hz (Mic FWD)	3.854 Pa at 112.5 Hz (Mic FWD)

Table 2.6: Experimental Results of Aluminum Tube with Dome End Caps (Fixed-Translation Condition) using Acoustic Excitation

Chapter 3

Comparison of Graphs between End Cap Configurations and Boundary Conditions

In this chapter, comparing graphs with different end cap configurations (Flat and Dome End Caps) and different boundary conditions (Free-Free, Fixed-Free, Fixed-Translation) were presented.

Comparison of graphs:

The graphs for the Flat and Dome end cap configurations are compared for the following boundary conditions:

- (i) Free-Free Boundary Condition
- (ii) Fixed-Free Boundary Condition
- (iii) Fixed-Translation Boundary Condition

The graphs for the Free-Free, Fixed-Free and Fixed-Translation conditions are then compared for the following end cap configurations:

- (i) Dome End Cap Configuration.
- (ii) Flat End Cap Configuration.

3.1 Comparison of Graphs between Dome and Flat End Cap Configurations Under the Free-Free Condition:

Results:

Figure 3.1 shows the Sound Level (dB) and Frequency (Hz) recorded by the AFT microphone in the aluminum tube under the free-free condition, comparing the results obtained for the dome and flat end caps. The first peak was recorded at a Sound Level of 105.132 dB at 112.5 Hz for Mic AFT for dome end caps and 97.230 dB at 95 Hz for Mic AFT for flat end caps.

Figure 3.2 compares the graphs for the Sound Level (dB) and Frequency (Hz) recorded by the FWD microphone in the aluminum tube under the free-free condition for dome and flat end caps. The first peak was recorded at a Sound Level of 105.687 dB at 112.5 Hz for Mic FWD for dome end caps and 99.288 dB at 91.5 Hz for Mic FWD for flat end caps.

Figure 3.3 shows the graphs for the Sound Pressure (Pa) and Frequency (Hz) recorded by the AFT microphone in the aluminum tube under the free-free condition for dome and flat end caps. The first peak was recorded at a Sound Level of 3.611 Pa at 112.5 Hz for Mic AFT for dome ends and 1.454 Pa at 95 Hz for Mic AFT for flat end caps.

Figure 3.4 compares the graphs for the Sound Pressure (Pa) and Frequency (Hz) recorded by the FWD microphone in the aluminum tube under the free-free condition for dome and flat end caps. The first peak was recorded at a Sound Level of 3.849 Pa at 112.5 Hz for Mic FWD for dome ends and 1.843 Pa at 91.5 Hz for Mic FWD for flat end caps.

Figure 3.5 compares the graphs of the Acceleration (m/s^2) and Frequency (Hz) measured by the accelerometer placed at the FWD end in the aluminum tube for both dome and flat end caps.

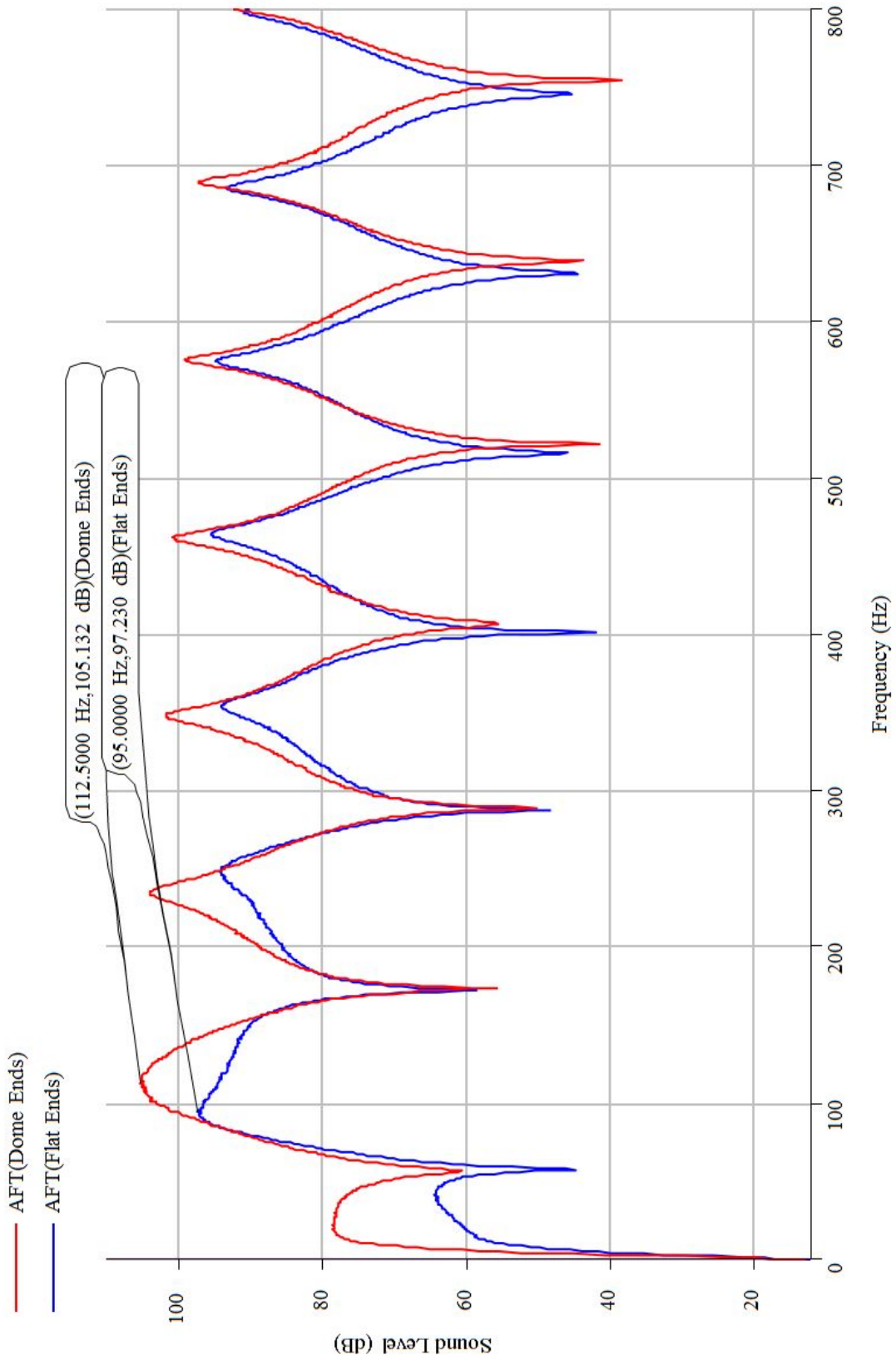

Figure 3.1: Mic AFT (dB) Vs Frequency (Hz) (Aluminum Tube with Free-Free Condition) (Dome vs Flat)

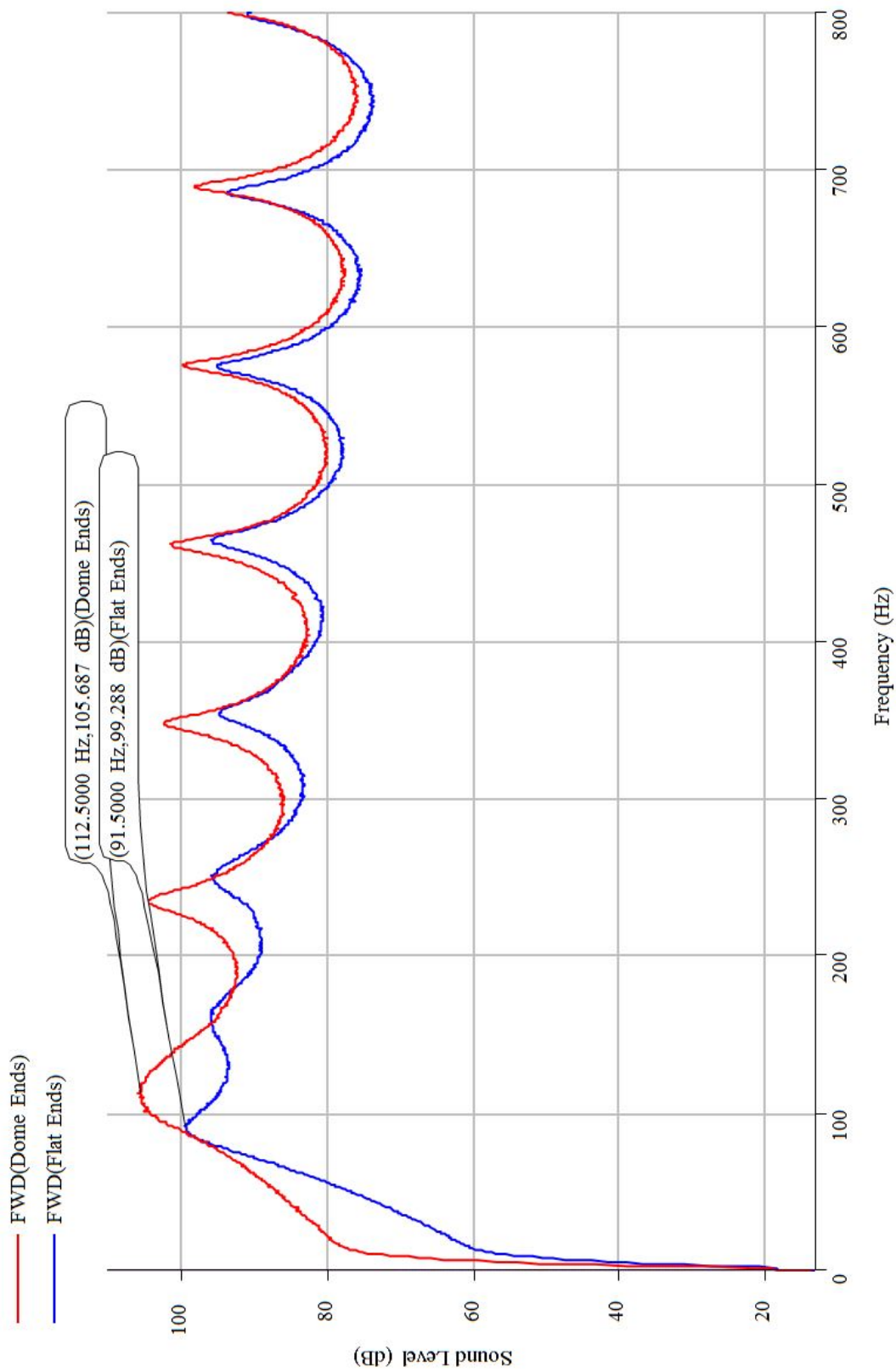

Figure 3.2: Mic FWD (dB) Vs Frequency (Hz) (Aluminum Tube with Free-Free Condition) (Dome vs Flat)

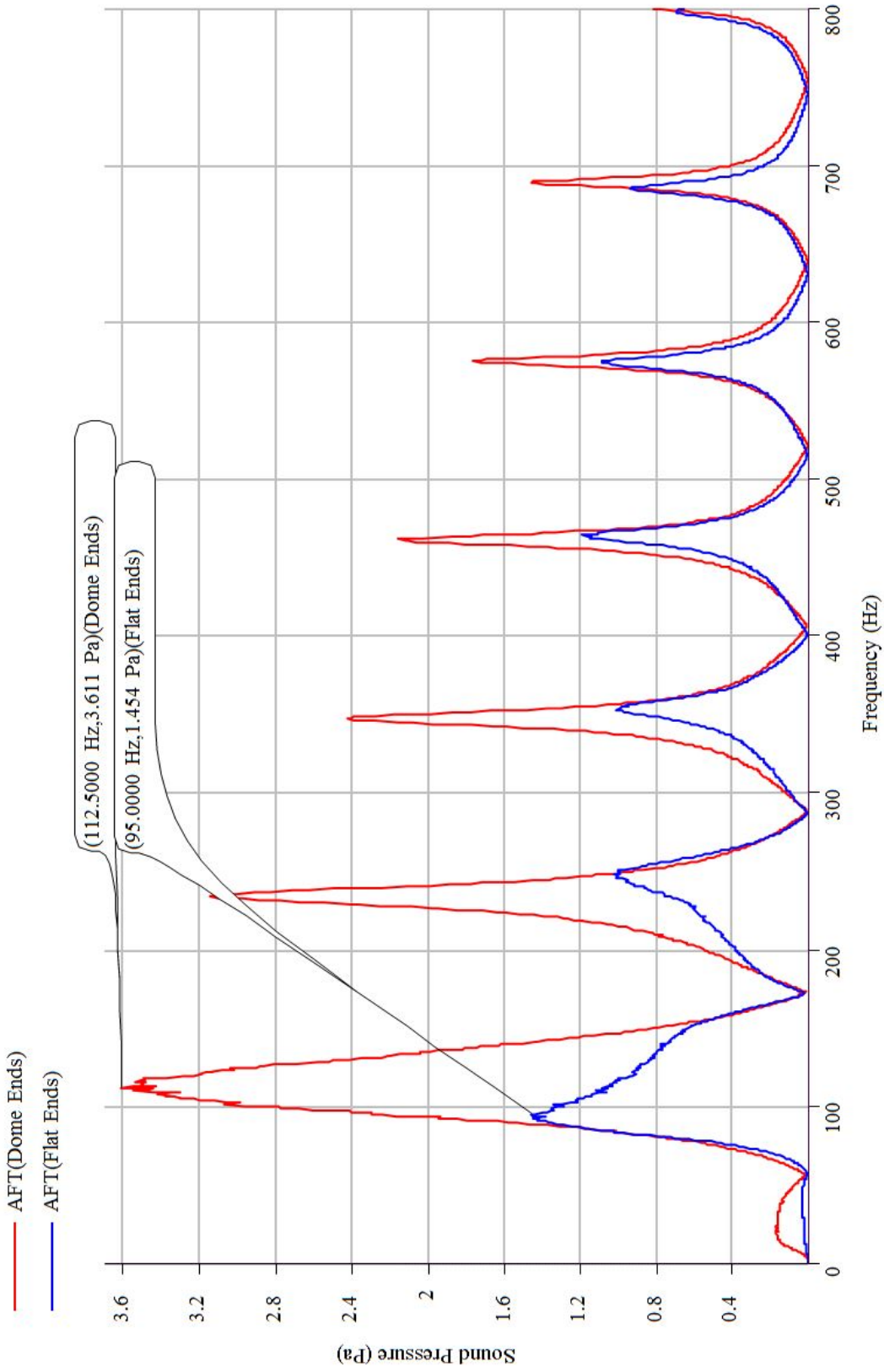

Figure 3.3: Mic AFT (Pa) Vs Frequency (Hz) (Aluminum Tube with Free-Free Condition) (Dome vs Flat)

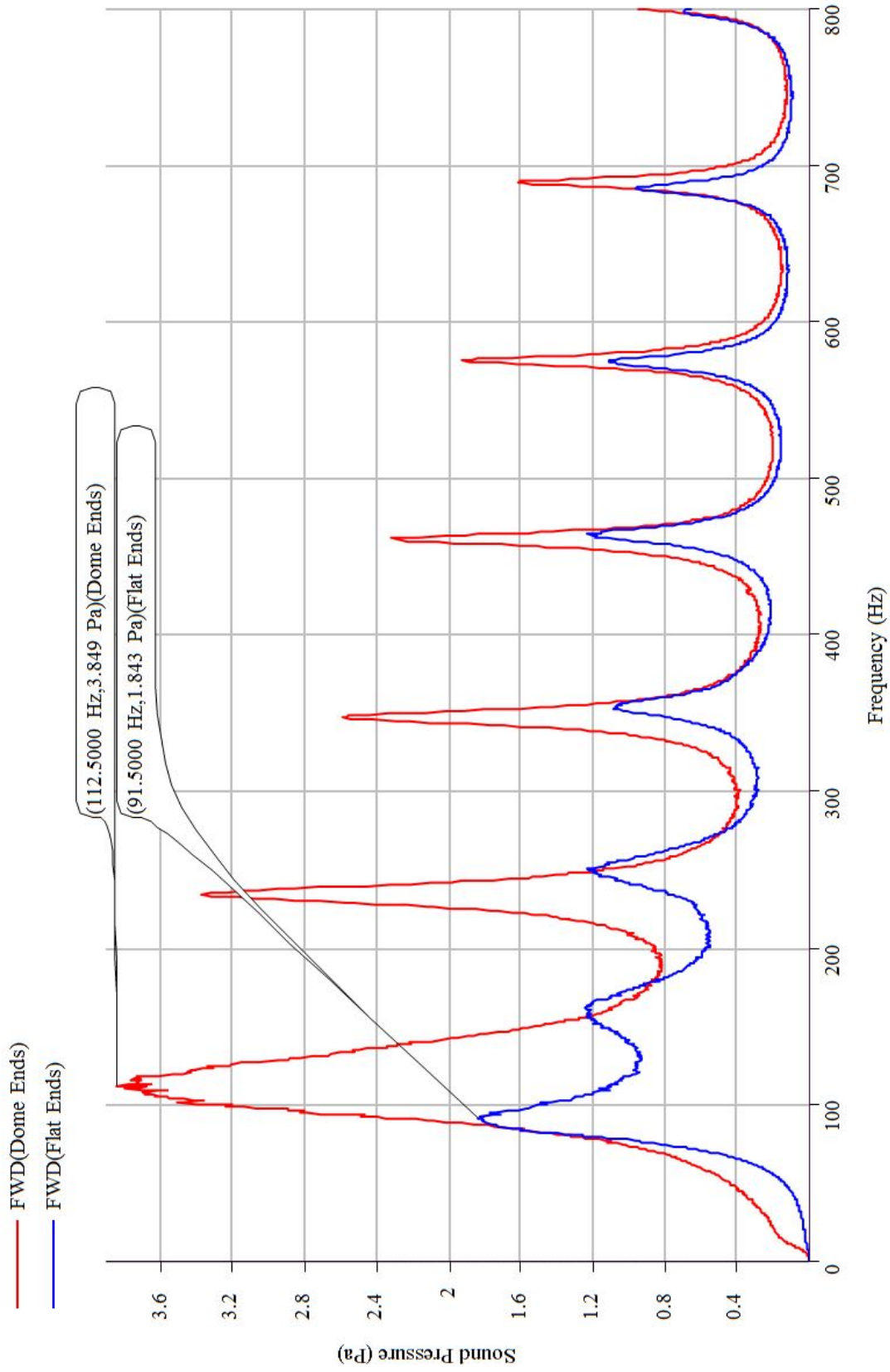

Figure 3.4: Mic FWD (Pa) Vs Frequency (Hz) (Aluminum Tube with Free-Free Condition) (Dome vs Flat)

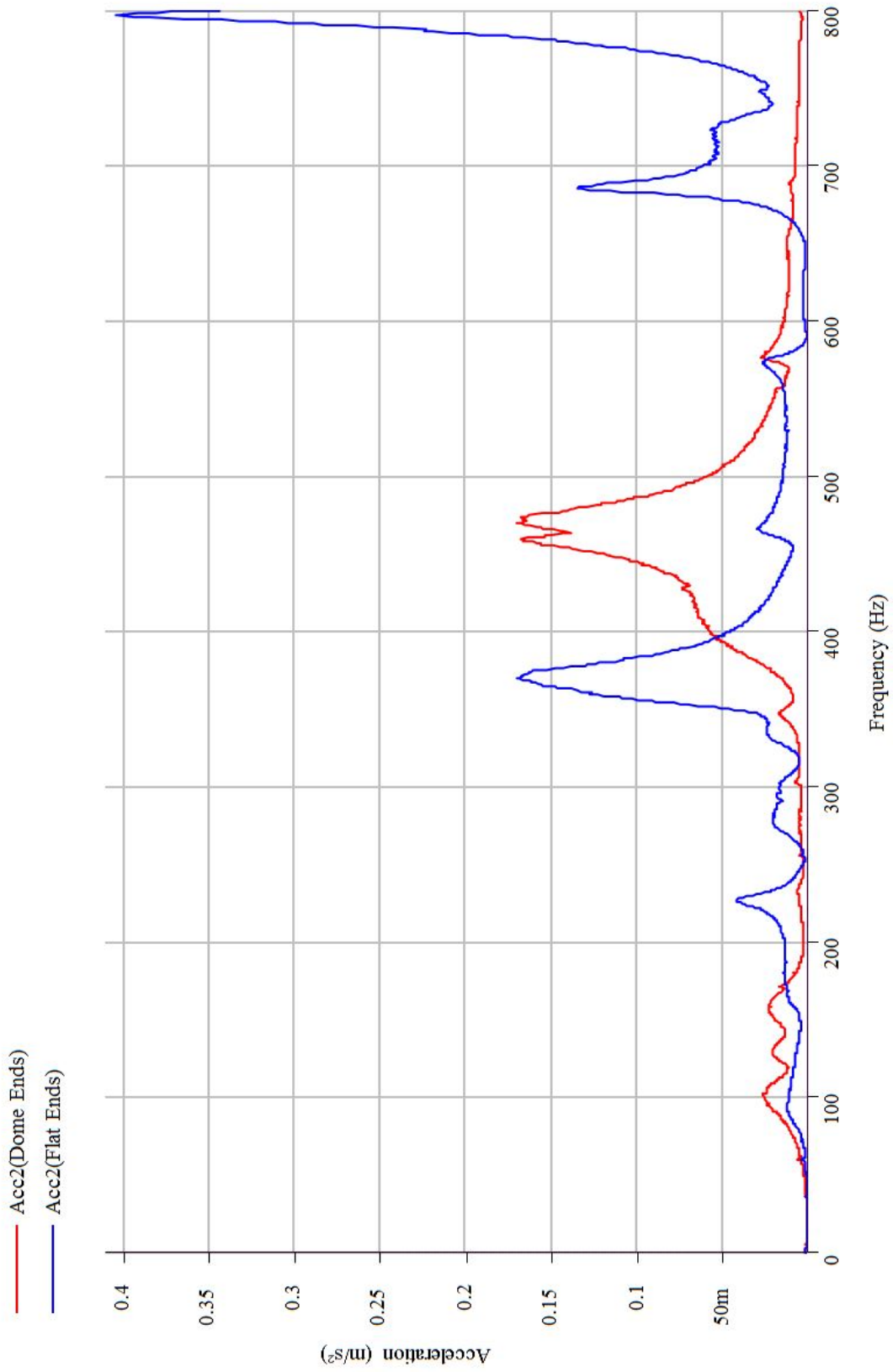

Figure 3.5: Acceleration (m/s^2) Vs Frequency (Hz) (Aluminum Tube with Free-Free Condition) (Dome vs Flat)

3.2 Comparison of graphs between Dome and Flat End Cap Configurations Under the Fixed-Free Condition:

Results:

Figure 3.6 compares the graphs for the Sound Level (dB) and compares the graphs for the Sound Level (dB) and Frequency (Hz) for the AFT microphone mounted in the aluminum tube under the fixed-free condition with either dome or flat end caps. The first peak was recorded at a Sound Level of 105.160 dB at 112.5 Hz for Mic AFT for dome end caps and 97.157 dB at 95 Hz for Mic AFT for flat end caps.

Figure 3.7 compares the graphs of the Sound Level (dB) and Frequency (Hz) for the FWD microphone in the aluminum tube under the fixed-free condition for dome and flat end caps. The first peak was recorded at a Sound Level of 105.712 dB at 112.5 Hz for Mic FWD for dome end caps and 99.185 dB at 91.5 Hz for Mic FWD for flat end caps.

Figure 3.8 compares the graphs of the Sound Pressure (Pa) and Frequency (Hz) for the AFT microphone in the aluminum tube under the fixed-free condition for dome and flat end caps. The first peak was recorded at a Sound Level of 3.623 Pa at 112.5 Hz for Mic AFT for dome end caps and 1.442 Pa at 95 Hz for Mic AFT for flat end caps.

Figure 3.9 compares the graphs of the Sound Pressure (Pa) and Frequency (Hz) for the FWD microphone in the aluminum tube under the fixed-free condition for dome and flat end caps. The first peak was recorded at a Sound Level of 3.860 Pa at 112.5 Hz for Mic FWD for dome end caps and 1.821 Pa at 91.5 Hz for Mic FWD for flat end caps.

Figure 3.10 shows the data for Acceleration (m/s^2) and Frequency (Hz) measured by the accelerometer placed at the FWD end of the aluminum tube for both the dome and flat end caps.

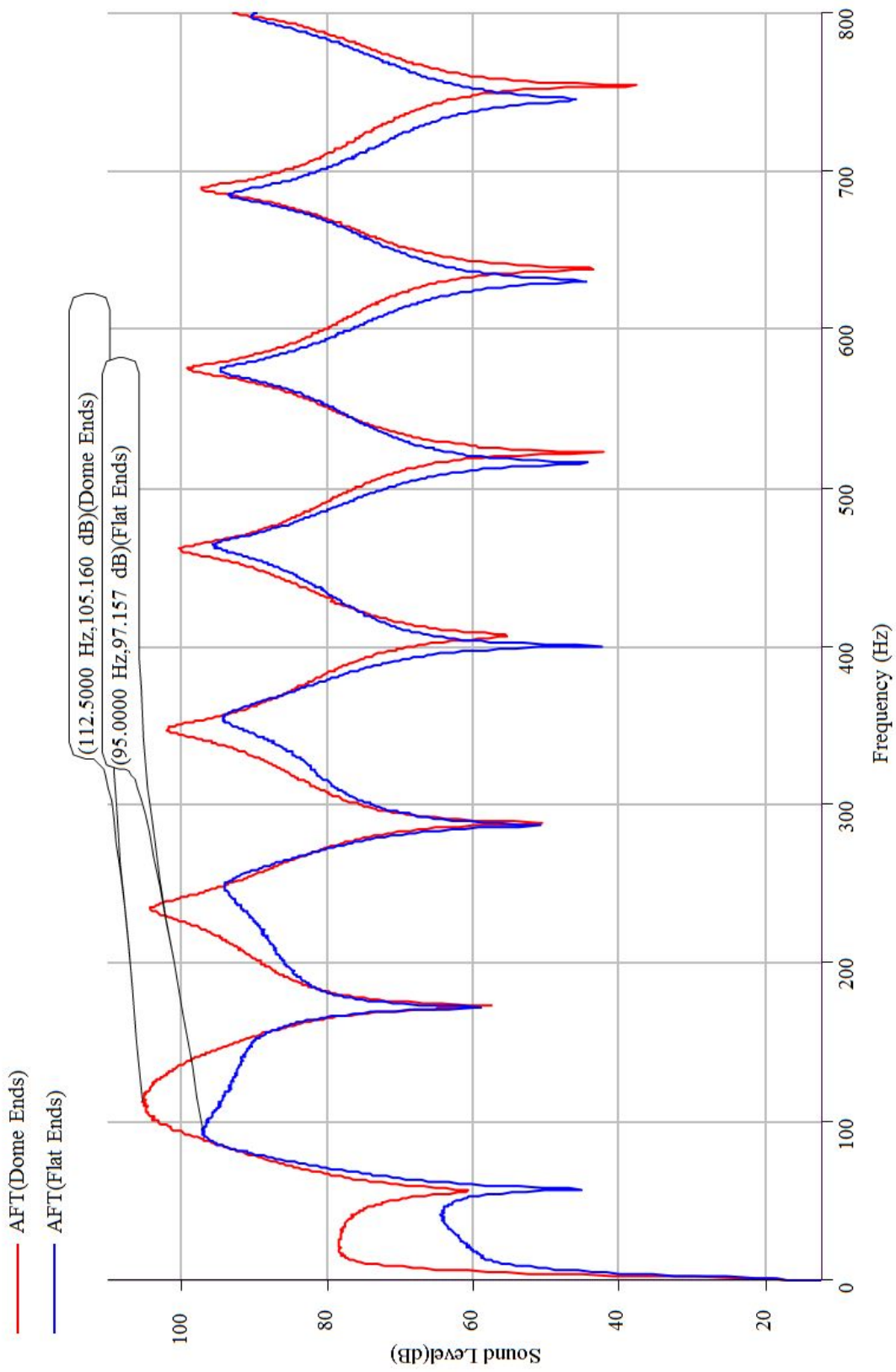

Figure 3.6: Mic AFT (dB) Vs Frequency (Hz) (Aluminum Tube with Fixed-Free Condition) (Dome vs Flat)

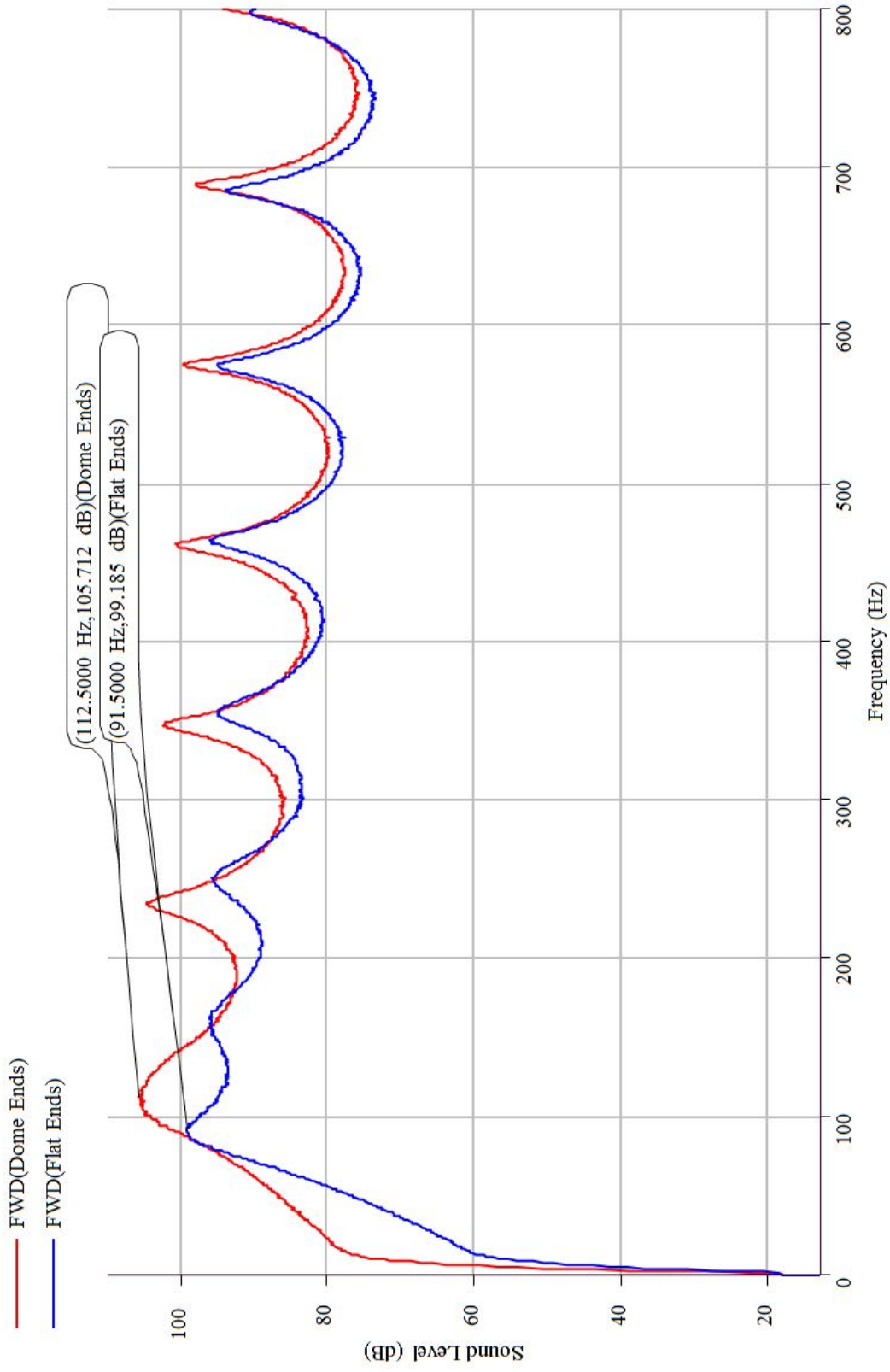

Figure 3.7: Mic FWD (dB) Vs Frequency (Hz) (Aluminum Tube with Fixed-Free Condition) (Dome vs Flat)

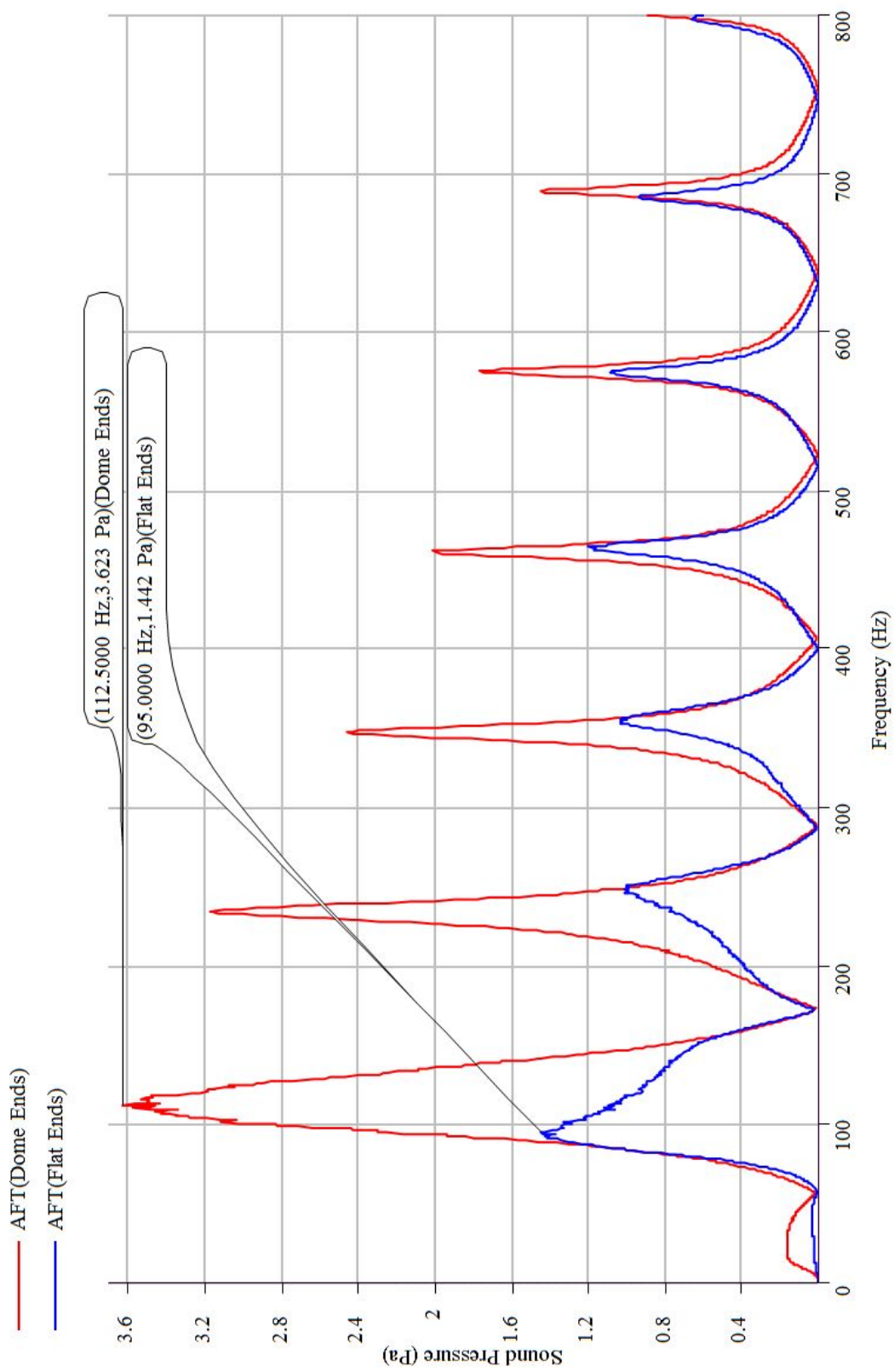

Figure 3.8: Mic AFT (Pa) Vs Frequency (Hz) (Aluminum Tube with Fixed-Free Condition) (Dome vs Flat)

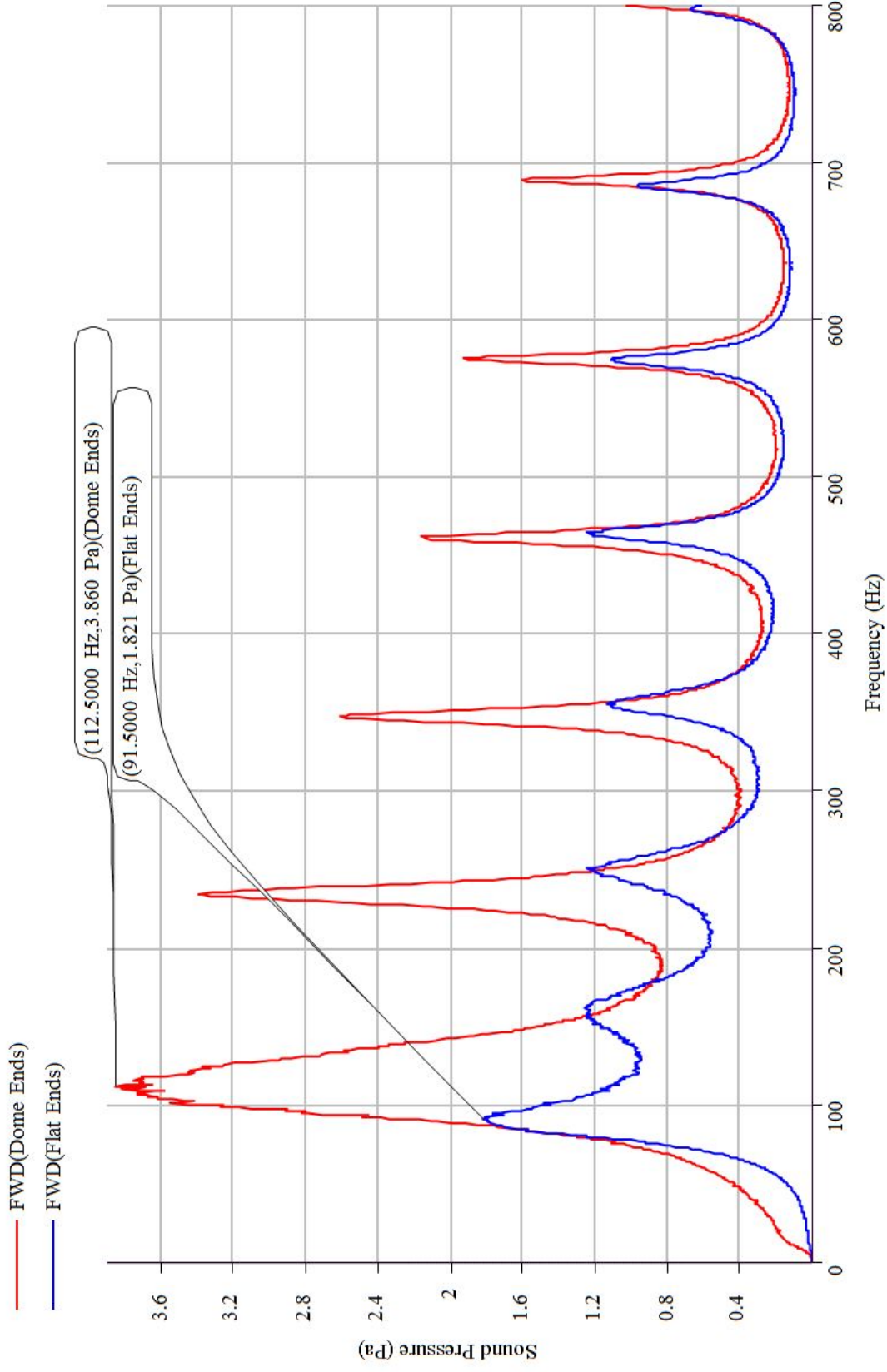

Figure 3.9: Mic FWD (Pa) Vs Frequency (Hz) (Aluminum Tube with Fixed-Free Condition) (Dome vs Flat)

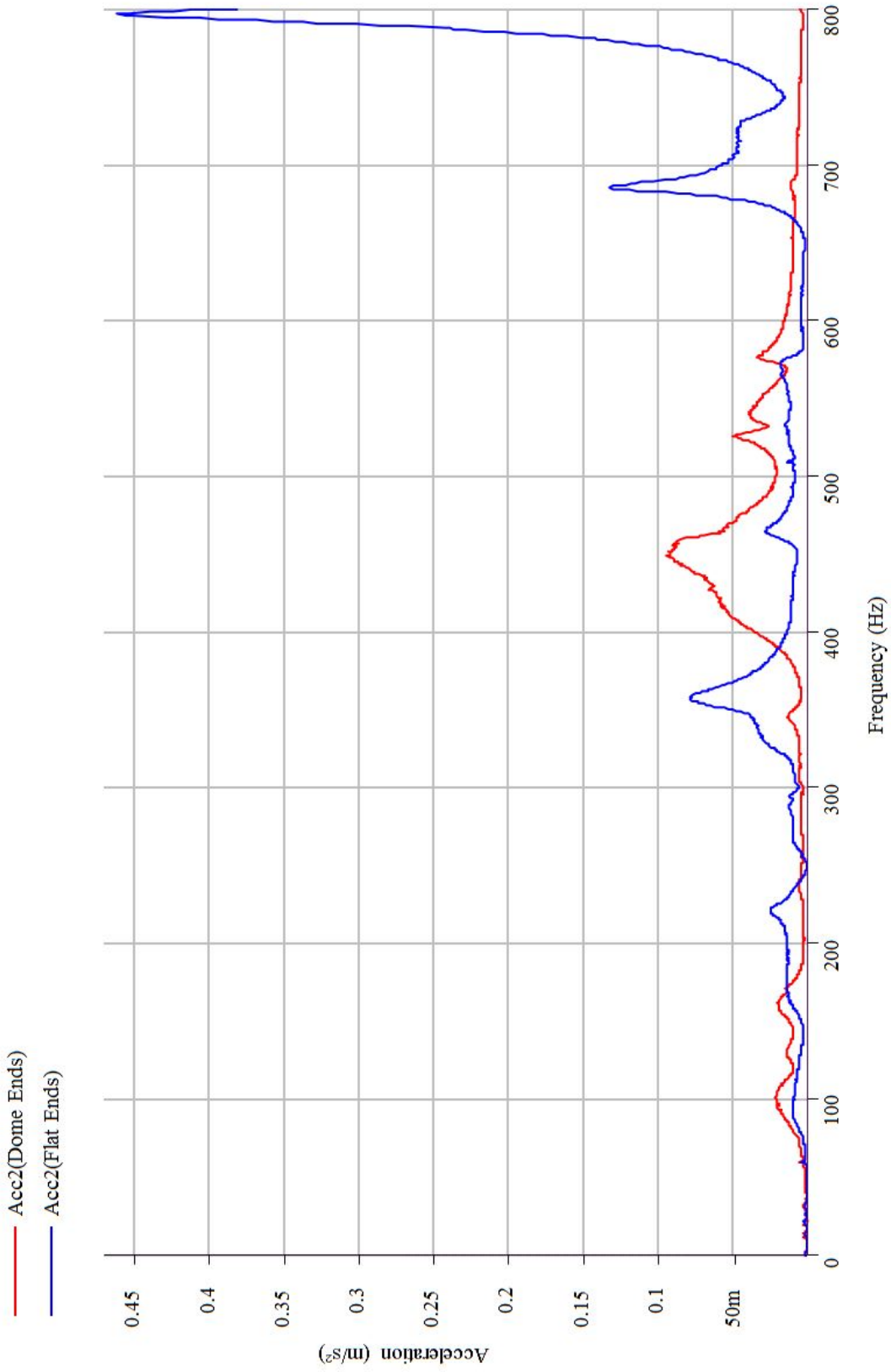

Figure 3.10: Acceleration (m/s^2) Vs Frequency (Hz) (Aluminum Tube with Fixed-Free Condition) (Dome vs Flat)

3.3 Comparison of graphs between Dome and Flat End Cap Configurations Under the Fixed-Translation Condition:

Results:

Figure 3.11 compares the graphs of Sound Level (dB) and Frequency (Hz) for the AFT microphone mounted in the aluminum tube under the fixed-translation condition for dome and flat end caps. The first peak was recorded at a Sound Level of 105.144 dB at 112.5 Hz for Mic AFT for dome ends and 97.138 dB at 95 Hz for Mic AFT for flat end caps.

Figure 3.12 compares the graphs of Sound Level (dB) and Frequency (Hz) for the FWD microphone in the aluminum tube under the fixed-translation condition for dome and flat end caps. The first peak was recorded at a Sound Level of 105.697 dB at 112.5 Hz for Mic FWD for dome ends and 99.174 dB at 91.5 Hz for Mic FWD for flat end caps.

Figure 3.13 compares the graphs of Sound Pressure (Pa) and Frequency (Hz) for the AFT microphone in the aluminum tube under the fixed-translation condition for dome and flat end caps. The first peak was recorded at a Sound Level of 3.616 Pa at 112.5 Hz for Mic AFT for dome ends and 1.439 Pa at 95 Hz for Mic AFT for flat end caps.

Figure 3.14 compares the graphs of Sound Pressure (Pa) and Frequency (Hz) for the FWD microphone in the aluminum tube under the fixed-translation condition for dome and flat end caps. The first peak was recorded at a Sound Level of 3.854 Pa at 112.5 Hz for Mic FWD for dome ends and 1.819 Pa at 91.5 Hz for Mic FWD for flat end caps.

Figure 3.15 compares the graphs obtained for Acceleration (m/s^2) and Frequency (Hz) for an accelerometer placed at the FWD end of the aluminum tube for dome and flat end caps.

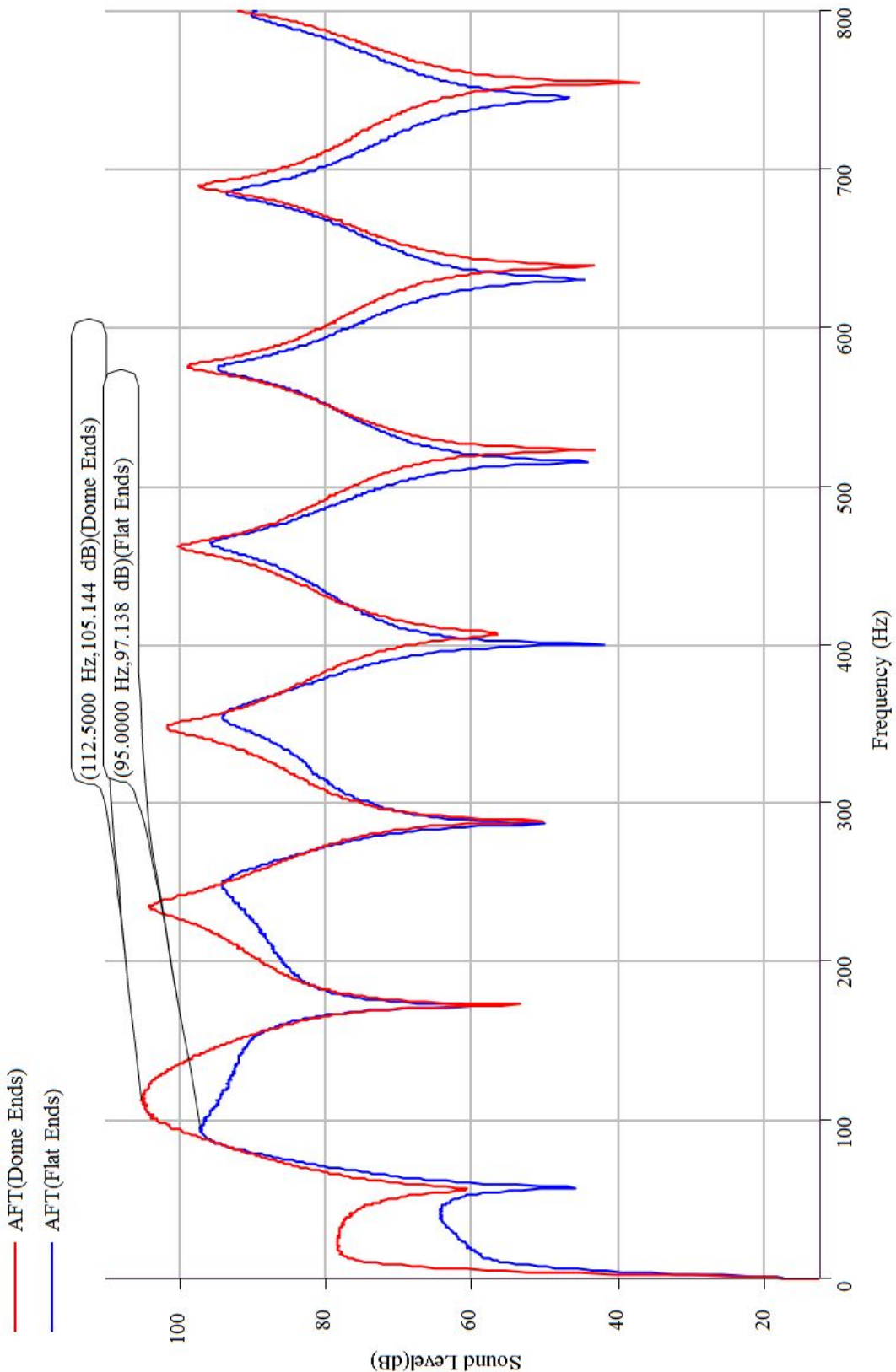

Figure 3.11: Mic AFT (dB) Vs Frequency (Hz) (Aluminum Tube with Fixed-Translation Condition) (Dome vs Flat)

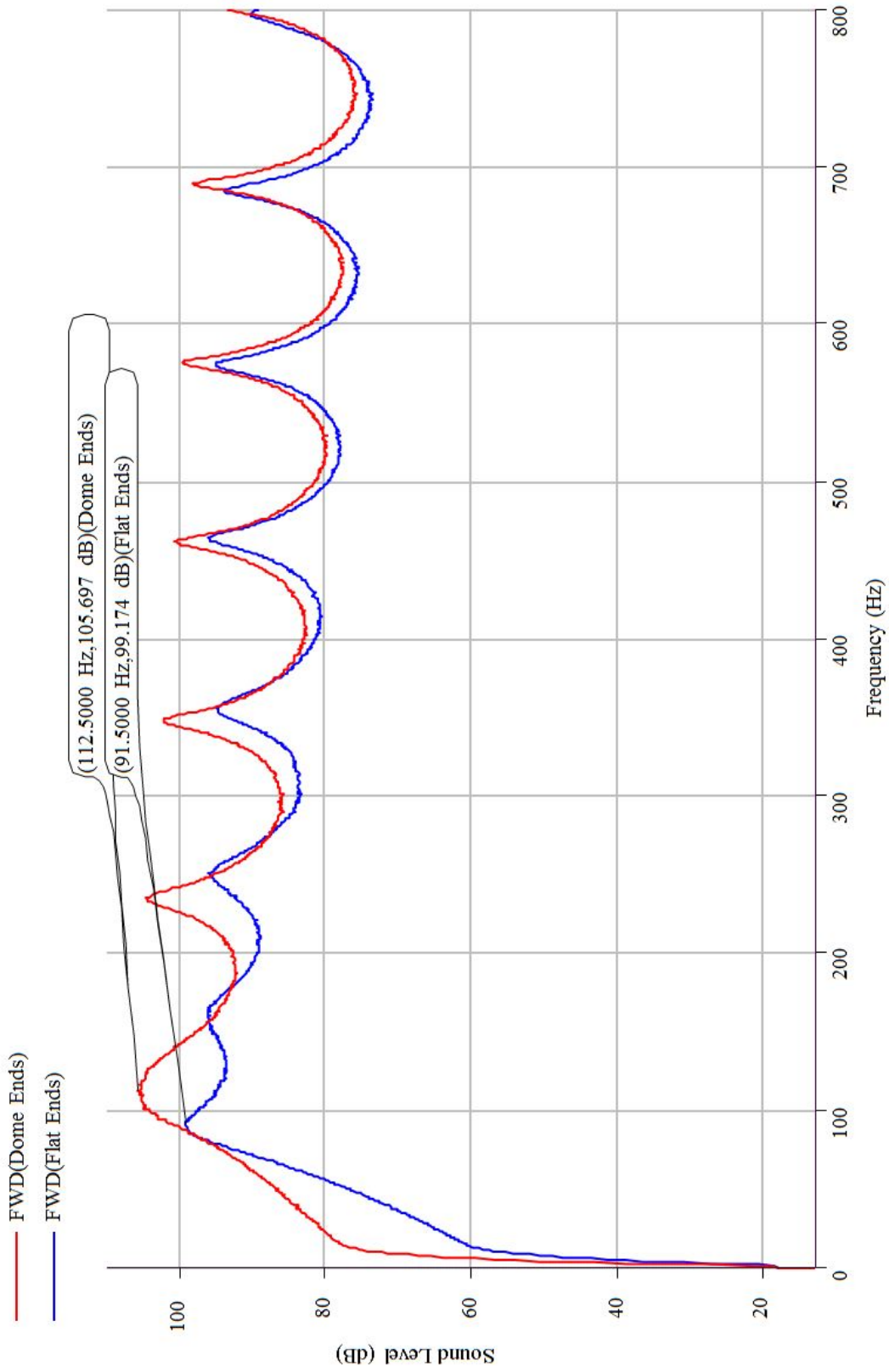

Figure 3.12: Mic FWD (dB) Vs Frequency (Hz) (Aluminum Tube with Fixed-Translation Condition) (Dome vs Flat)

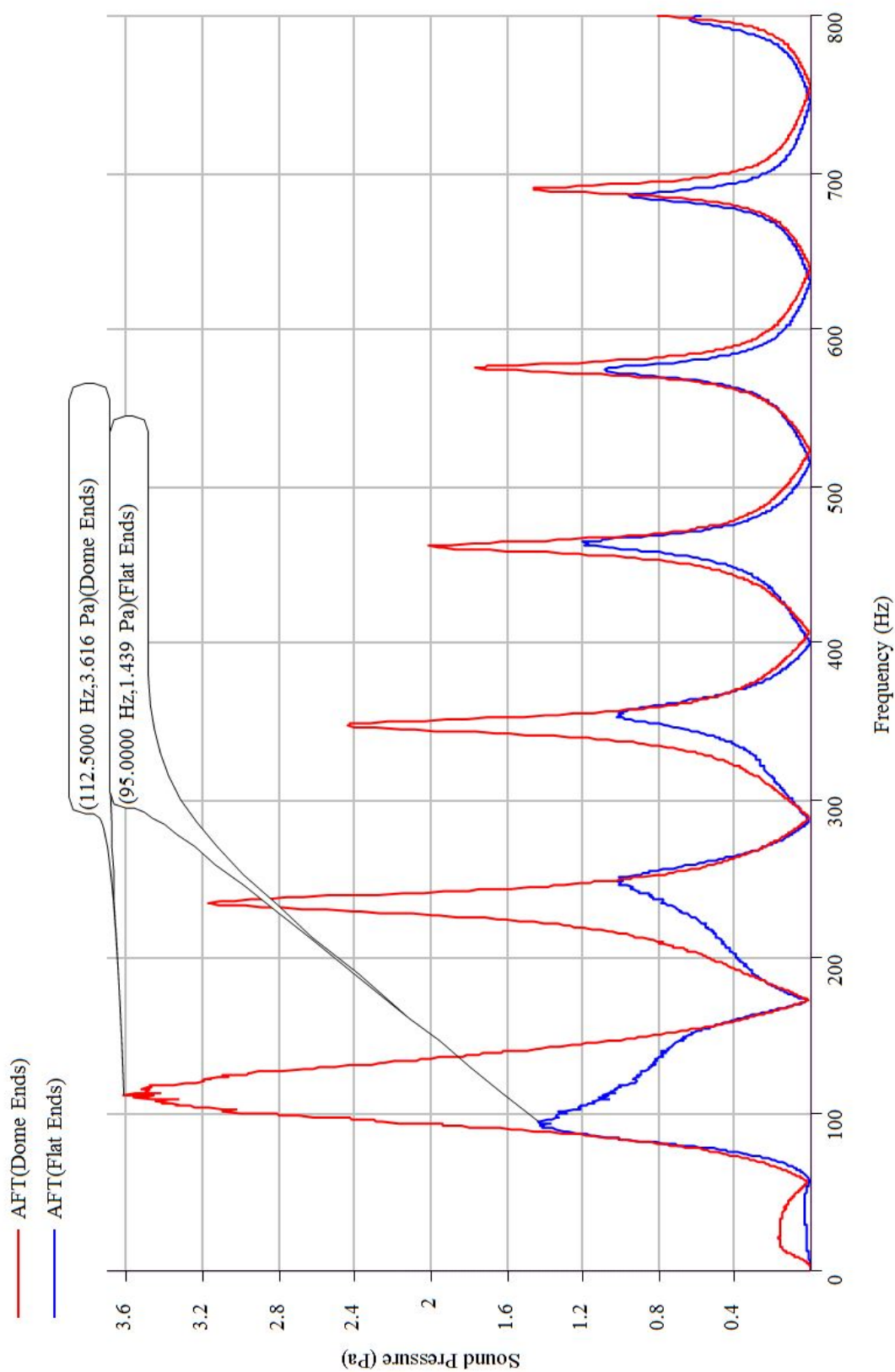

Figure 3.13: Mic AFT (Pa) Vs Frequency (Hz) (Aluminum Tube with Fixed-Translation Condition) (Dome vs Flat)

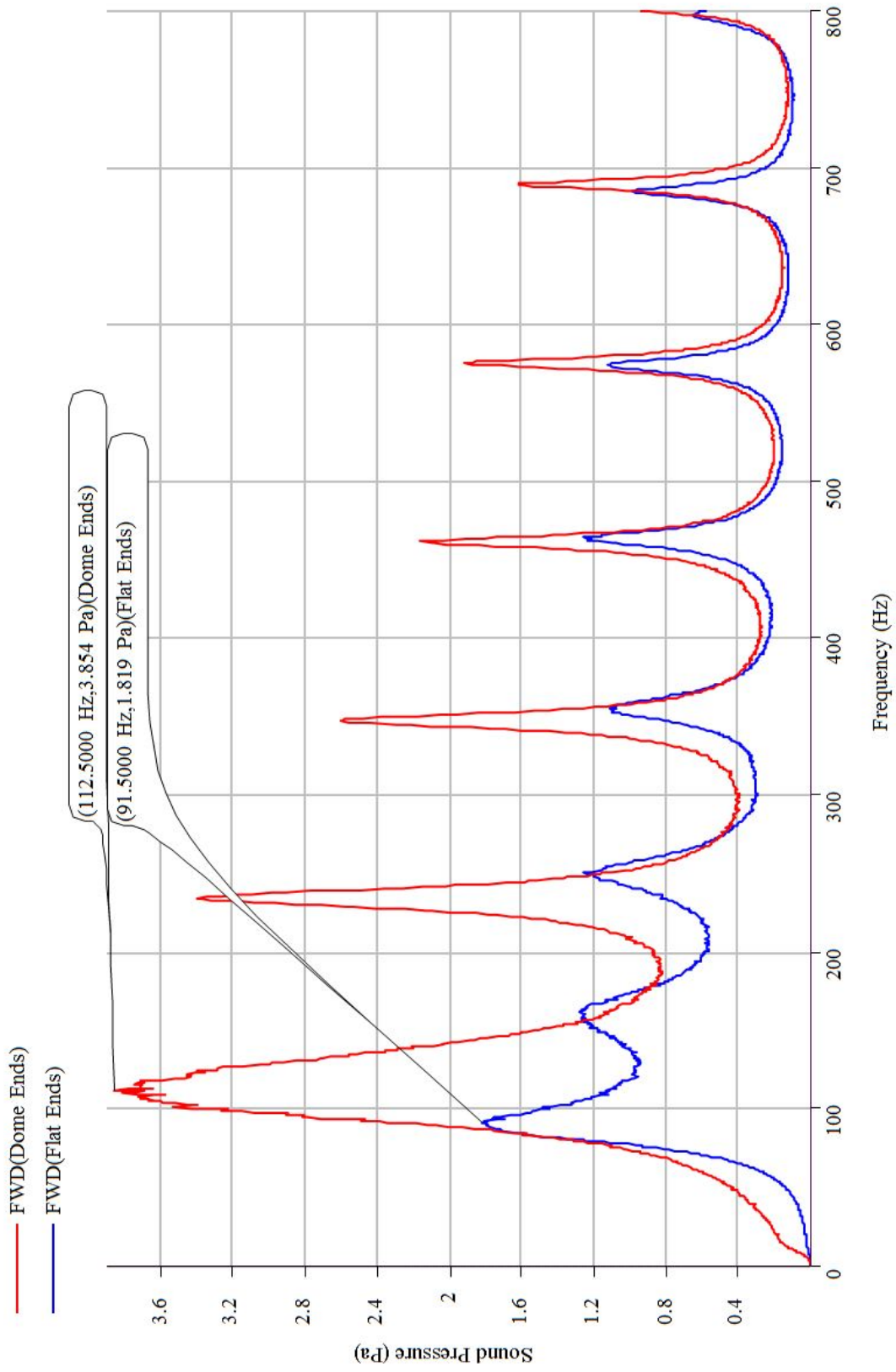

Figure 3.14: Mic FWD (Pa) Vs Frequency (Hz) (Aluminum Tube with Fixed-Translation Condition) (Dome vs Flat)

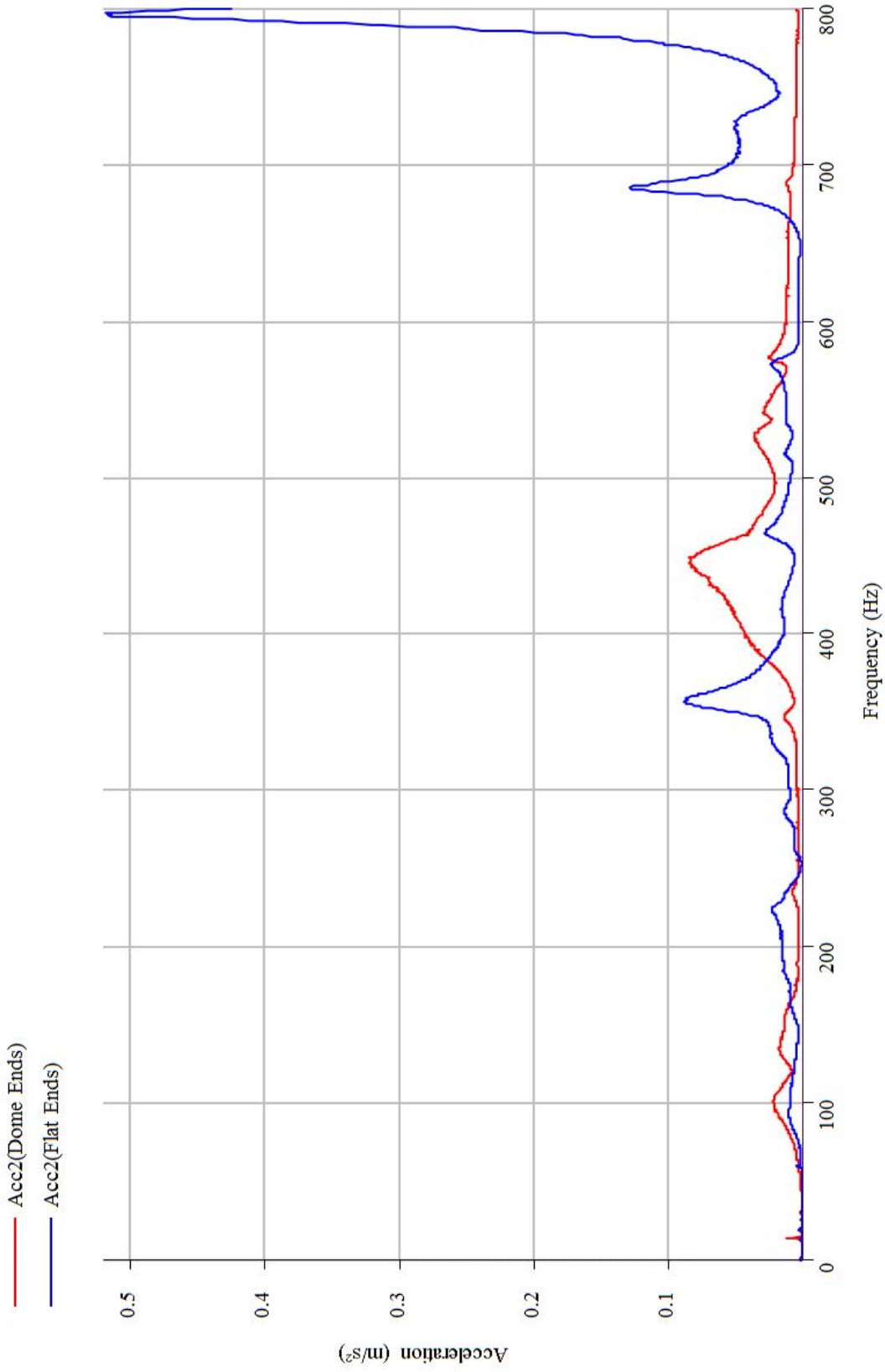

Figure 3.15: Acceleration (m/s^2) Vs Frequency (Hz) (Aluminum Tube with Fixed-Translation Condition) (Dome vs Flat)

3.4 Comparison of graphs between Free-Free, Fixed-Free and Fixed-Translation Condition for Dome End Cap Configuration:

Results:

Figure 3.16 compares the graphs of the Sound Level (dB) and Frequency (Hz) recorded by an AFT microphone mounted in the aluminum tube with dome end caps for three different boundary conditions (Free-Free vs Fixed-Free vs Fixed-Translation). At 112.5 Hz, the first peak was recorded at sound levels of 105.132 dB, 105.160 dB, and 105.144 dB for the Free-Free, Fixed-Free and Fixed-Translation conditions, respectively.

Figure 3.17 compares the graphs of the Sound Level (dB) and Frequency (Hz) recorded by the FWD microphone in the aluminum tube with dome end caps under all three boundary conditions. At 112.5 Hz, the first peak was recorded at sound levels of 105.687 dB, 105.712 dB, and 105.697 dB for the Free-Free, Fixed-Free and Fixed-Translation conditions, respectively.

Figure 3.18 compares the graphs of the Sound Pressure (Pa) and Frequency (Hz) recorded by the AFT microphone in the aluminum tube with dome end caps under all three boundary conditions. At 112.5 Hz, the first peak was recorded at sound pressures of 3.611 Pa, 3.623 Pa, and 3.616 Pa for the Free-Free, Fixed-Free and Fixed-Translation conditions, respectively.

Figure 3.19 compares the graphs of the Sound Pressure (Pa) and Frequency (Hz) recorded by the FWD microphone in the aluminum tube with dome end caps under all three boundary conditions. At 112.5 Hz, the first peak was recorded at sound pressures of 3.849 Pa, 3.860 Pa, and 3.854 Pa for the Free-Free, Fixed-Free and Fixed-Translation conditions, respectively.

Figure 3.20 compares the graphs of Acceleration (m/s^2) and Frequency (Hz) obtained by an accelerometer placed at the FWD end in the aluminum tube with dome end caps under all three boundary conditions.

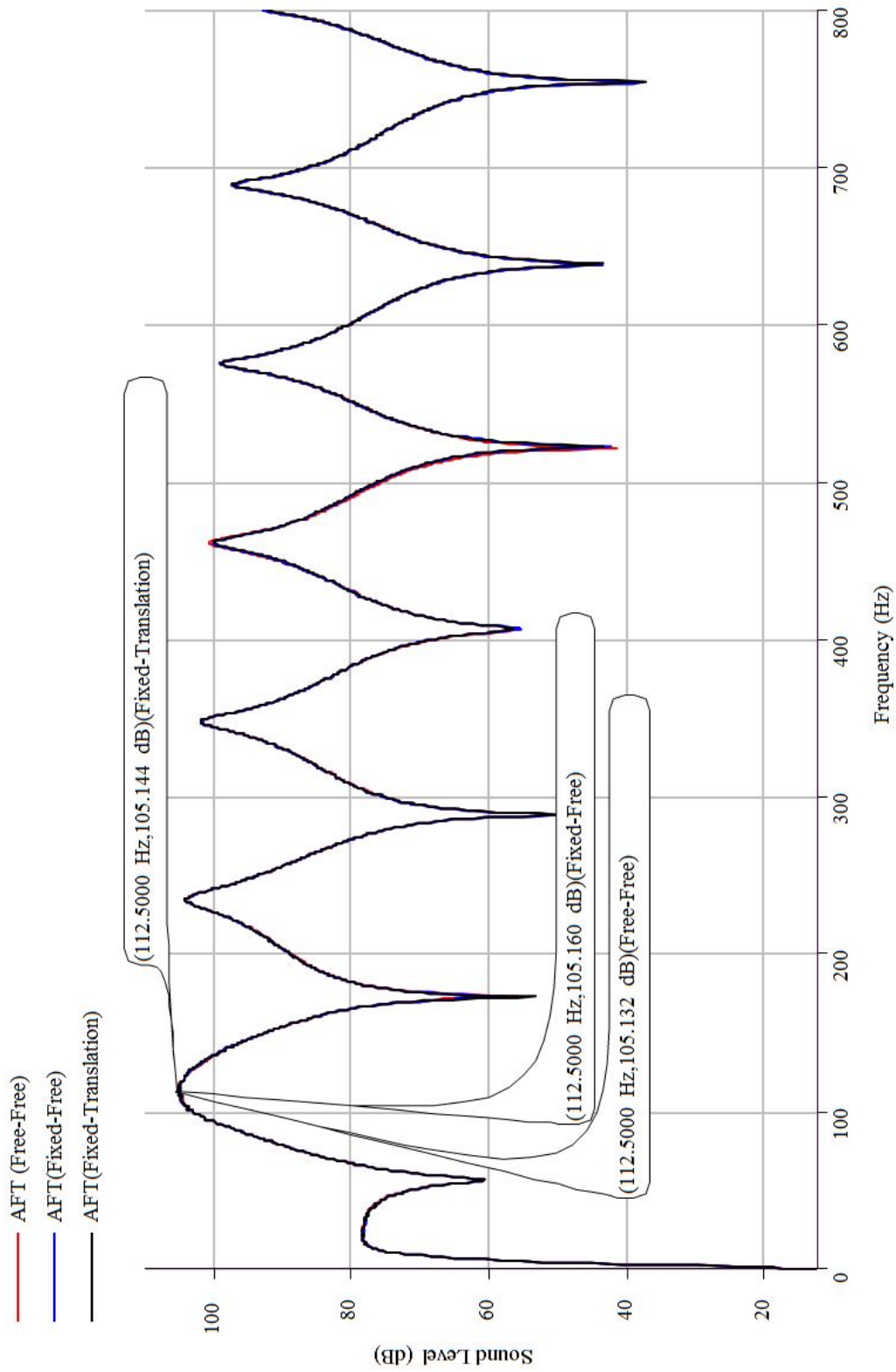

Figure 3.16: Mic AFT (dB) Vs Frequency (Hz) (Aluminum Tube with Dome End Cap) (Free-Free Vs Fixed-Free Vs Fixed-Translation)

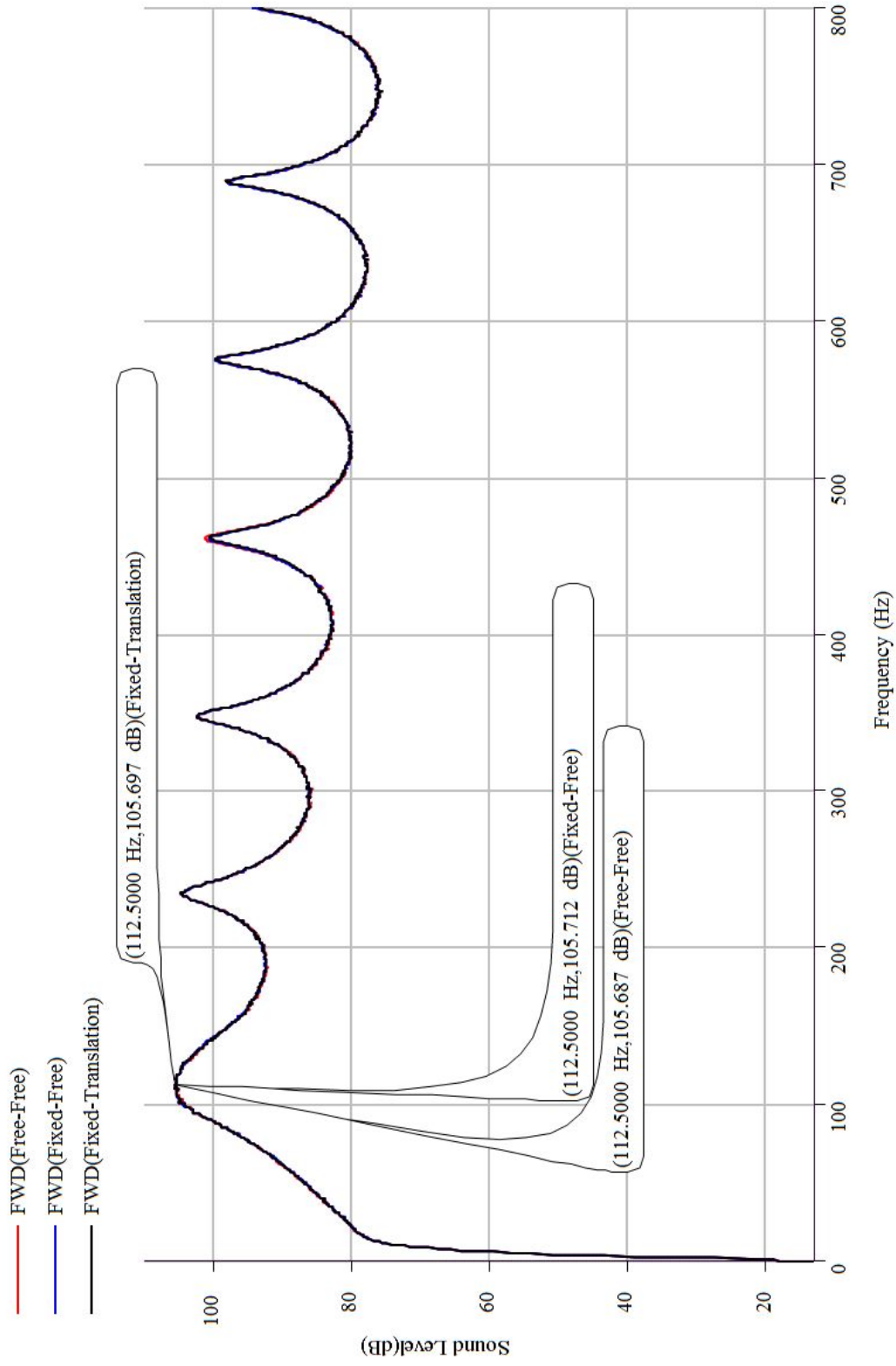

Figure 3.17: Mic FWD (dB) Vs Frequency (Hz) (Aluminum Tube with Dome End Cap) (Free-Free Vs Fixed-Free Vs Fixed-Translation)

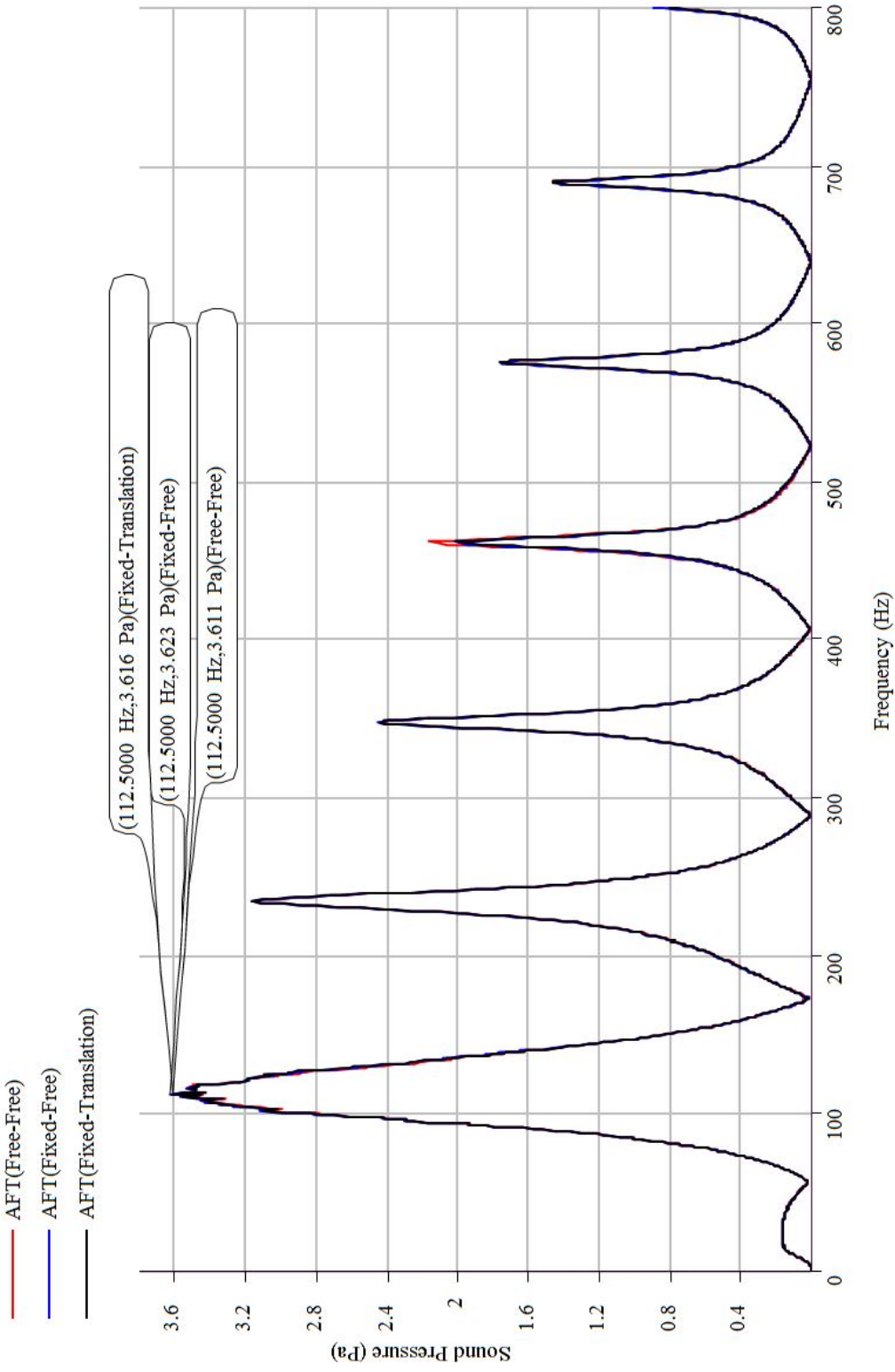

Figure 3.18: Mic AFT (Pa) Vs Frequency (Hz) (Aluminum Tube with Dome End Cap) (Free-Free Vs Fixed-Free Vs Fixed-Translation)

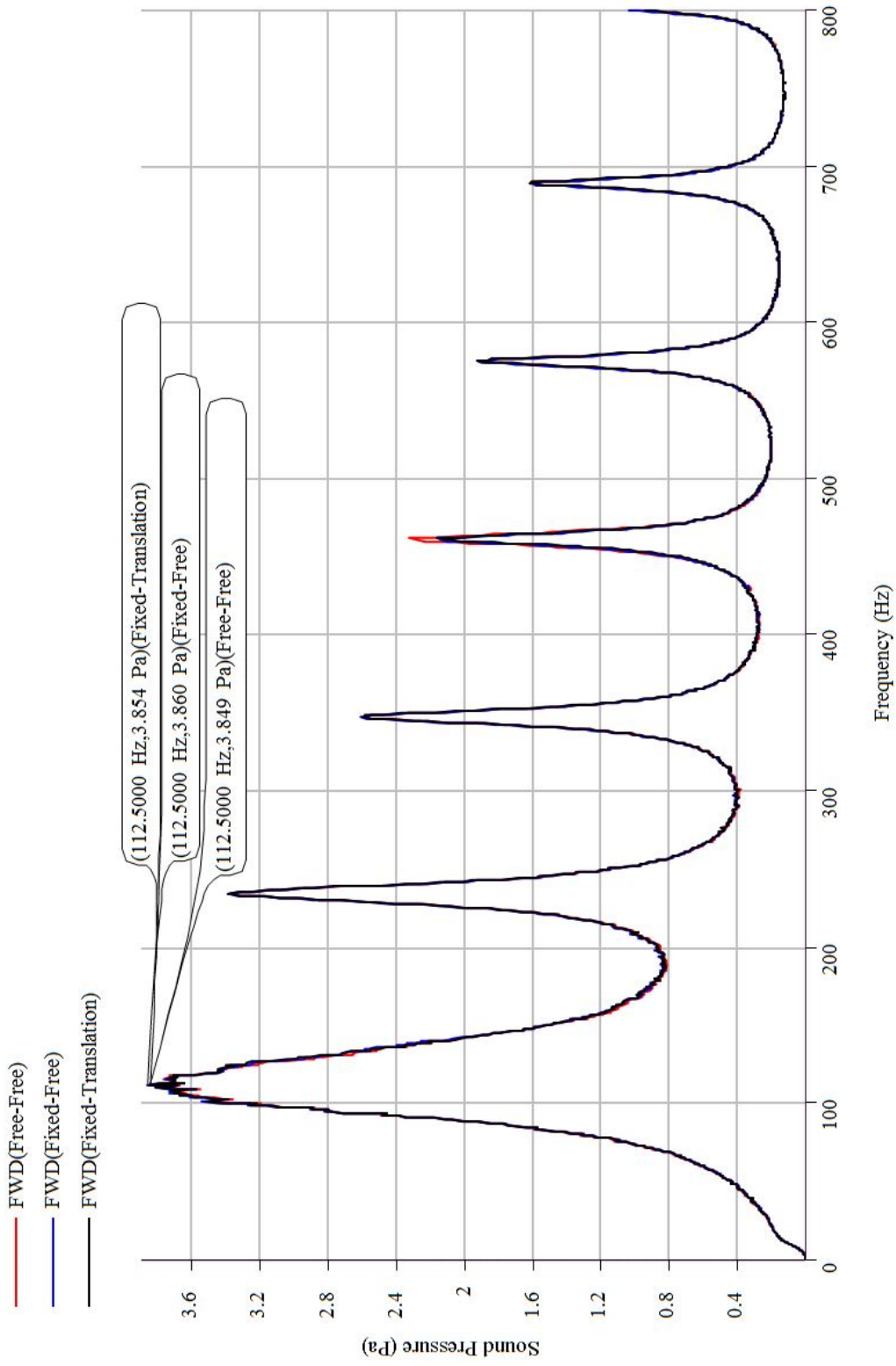

Figure 3.19: Mic FWD (Pa) Vs Frequency (Hz) (Aluminum Tube with Dome End Cap) (Free-Free Vs Fixed-Free Vs Fixed-Translation)

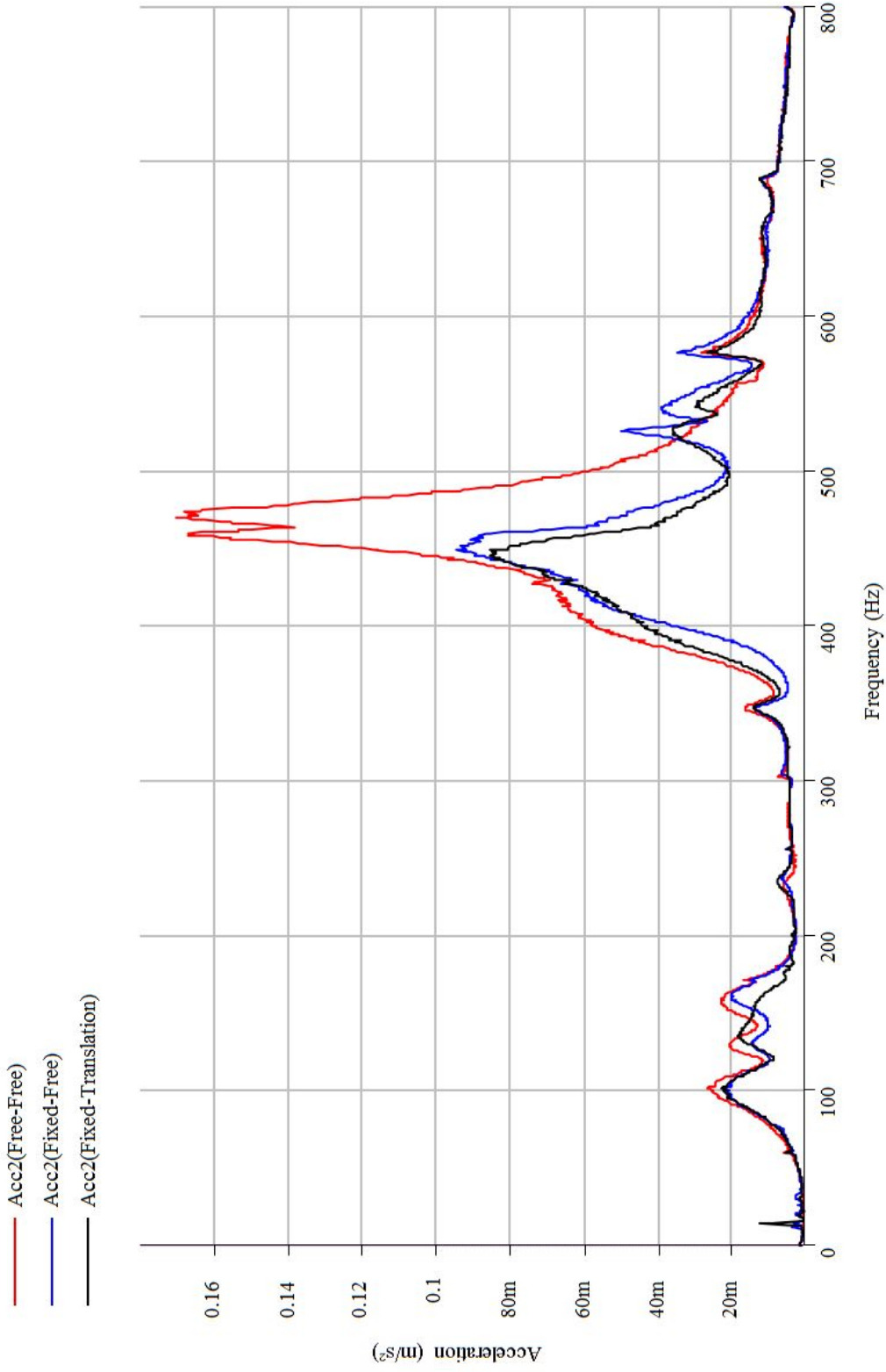

Figure 3.20: Acceleration (m/s^2) Vs Frequency (Hz) (Aluminum Tube with Dome End Cap) (Free-Free Vs Fixed-Free Vs Fixed-Translation)

3.5 Comparison of graphs between Free-Free, Fixed-Free and Fixed-Translation Condition for Flat End Cap Configuration:

Results:

Figure 3.21 compares the graphs of the Sound Level (dB) and Frequency (Hz) recorded by the AFT microphone in the aluminum tube with flat end caps for three different boundary conditions (Free-Free vs Fixed-Free vs Fixed-Translation). At 95 Hz, the first peak was recorded at Sound Levels of 97.230 dB, 97.157 dB, and 97.138 dB for the Free-Free, Fixed-Free and Fixed-Translation conditions, respectively.

Figure 3.22 compares the graphs of the Sound Level (dB) and Frequency (Hz) recorded by the FWD microphone in the aluminum tube with flat end caps under all three boundary conditions. At 91.5 Hz, the first peak was recorded at Sound Levels of 99.288 dB, 99.180 dB, and 99.174 dB for the Free-Free, Fixed-Free and Fixed-Translation conditions, respectively.

Figure 3.23 compares the graphs of the Sound Pressure (Pa) and Frequency (Hz) recorded by the AFT microphone in the aluminum tube with flat end caps under all three boundary conditions. At 95 Hz, the first peak was recorded at Sound Pressures of 1.454 Pa, 1.442 Pa, and 1.439 Pa for the Free-Free, Fixed-Free and Fixed-Translation conditions, respectively.

Figure 3.24 compares the graphs of the Sound Pressure (Pa) and Frequency (Hz) recorded by the FWD microphone in the aluminum tube with flat end caps under all three boundary conditions. At 91.5 Hz, the first peak was recorded at Sound Levels of 1.843 Pa, 1.821 Pa, and 1.819 Pa for the Free-Free, Fixed-Free and Fixed-Translation conditions, respectively.

Figure 3.25 compares the graphs of Acceleration (m/s^2) and Frequency (Hz) measured by the accelerometer placed at the FWD end in the aluminum tube with flat end caps under all three boundary conditions.

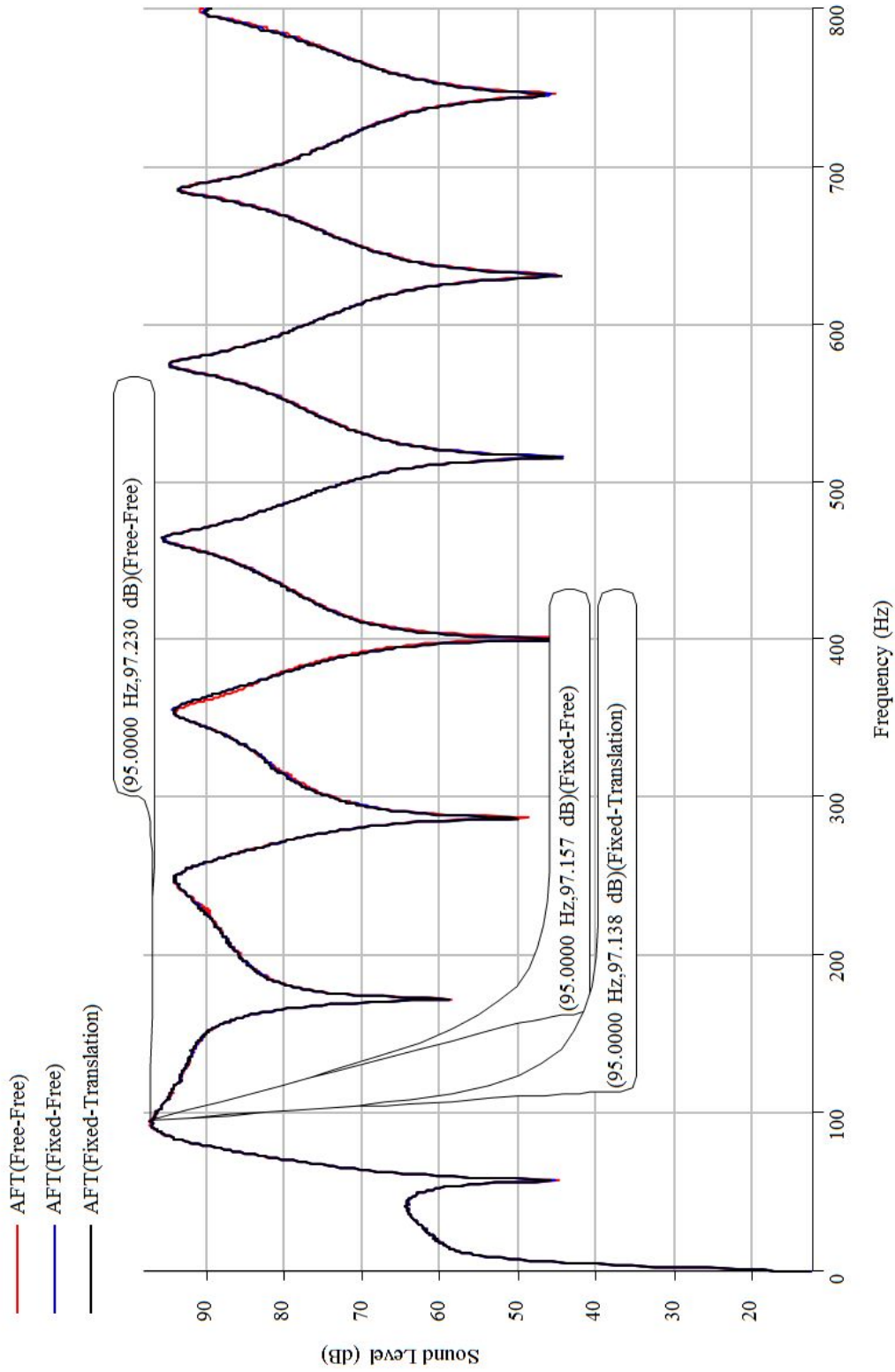

Figure 3.21: Mic AFT (dB) Vs Frequency (Hz) (Aluminum Tube with Flat End Cap) (Free-Free Vs Fixed-Free Vs Fixed-Translation)

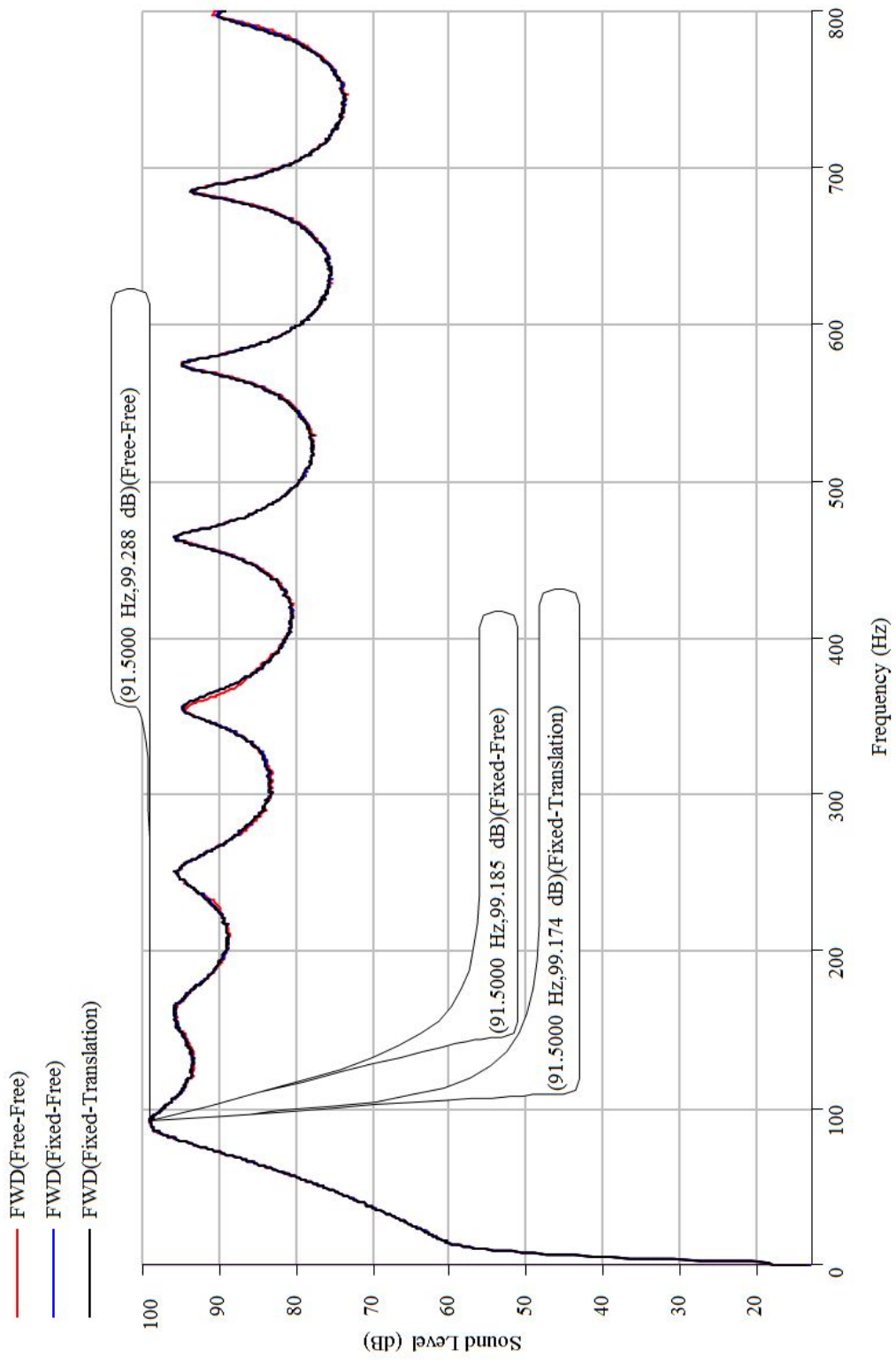

Figure 3.22: Mic FWD (dB) Vs Frequency (Hz) (Aluminum Tube with Flat End Cap) (Free-Free Vs Fixed-Free Vs Fixed-Translation)

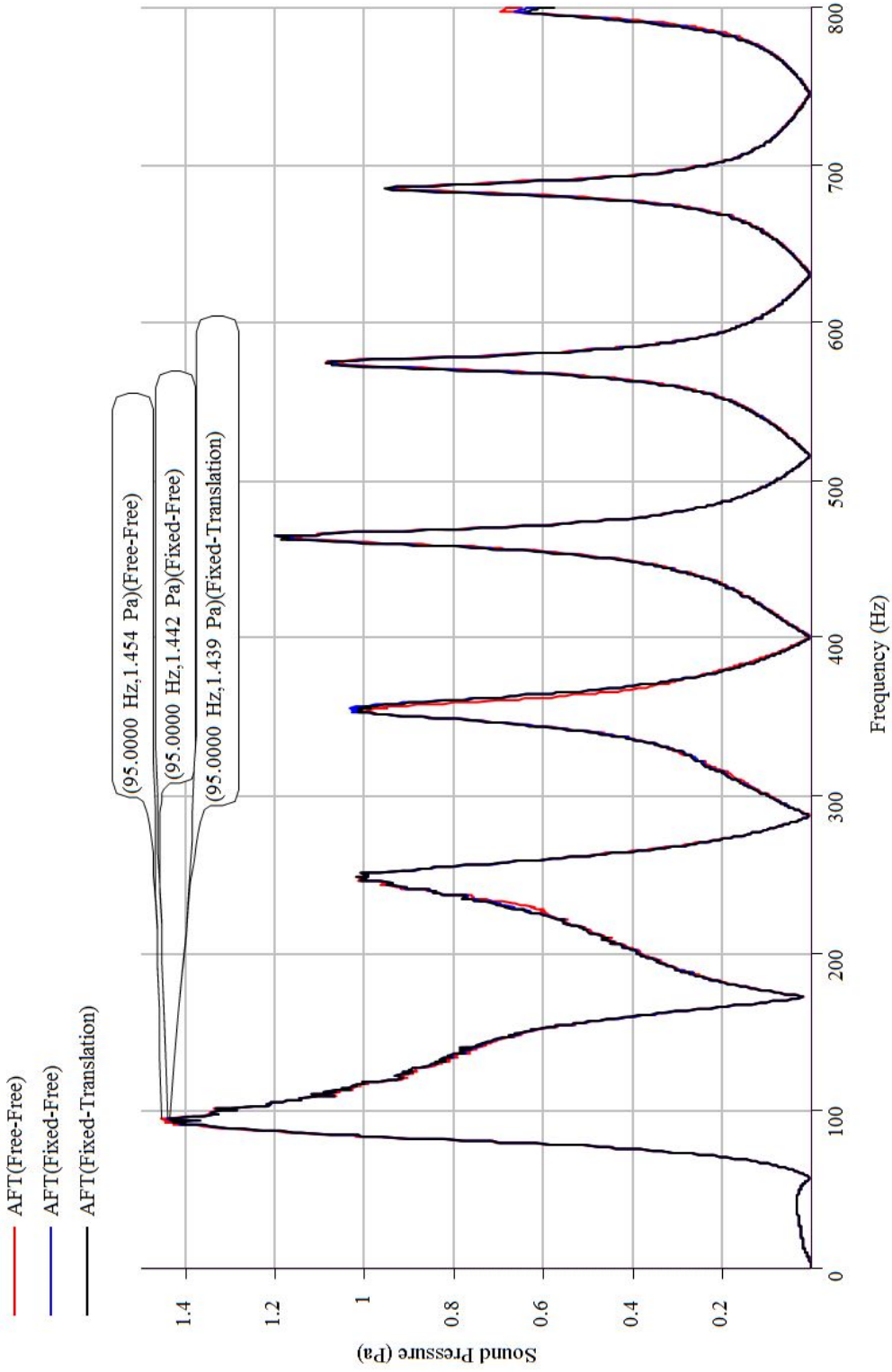

Figure 3.23: Mic AFT (Pa) Vs Frequency (Hz) (Aluminum Tube with Flat End Cap) (Free-Free Vs Fixed-Free Vs Fixed-Translation)

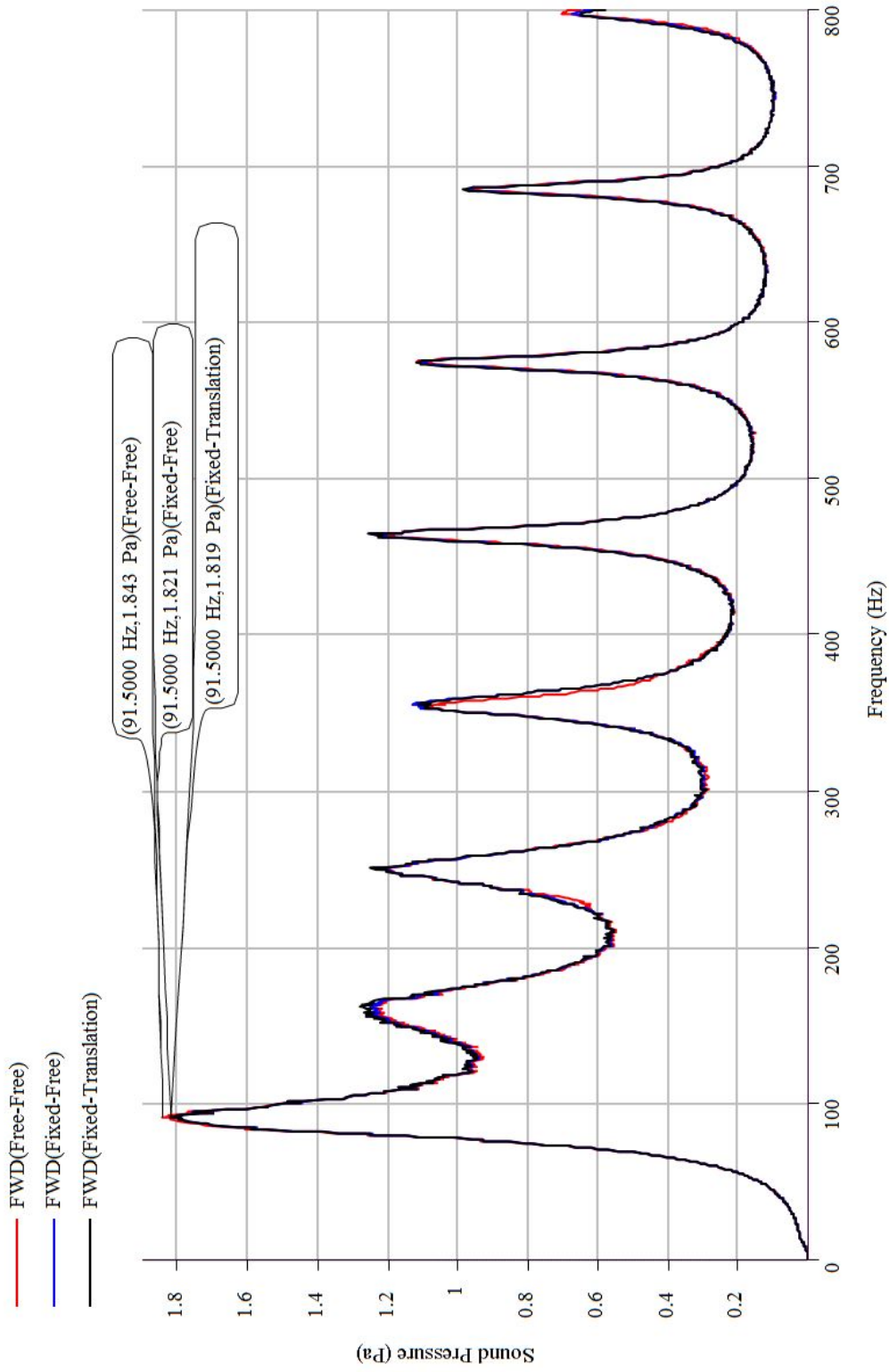

Figure 3.24: Mic FWD (Pa) Vs Frequency (Hz) (Aluminum Tube with Flat End Cap) (Free-Free Vs Fixed-Free Vs Fixed-Translation)

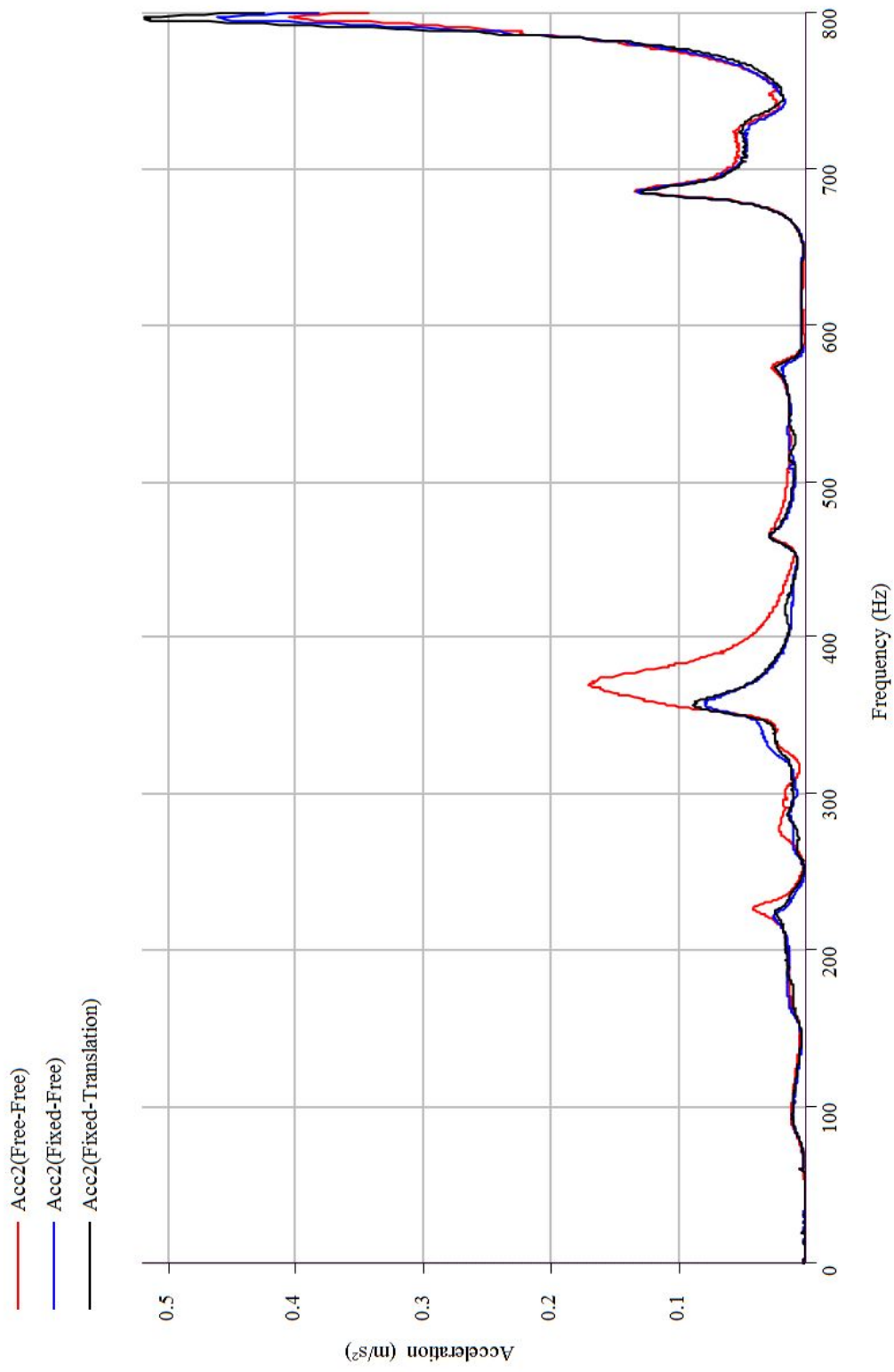

Figure 3.25: Acceleration (m/s^2) Vs Frequency (Hz) (Aluminum Tube with Flat End Cap) (Free-Free Vs Fixed-Free Vs Fixed-Translation)

Chapter 4

Numerical Model Analysis using MSC Nastran/Patran Software

This chapter presents the numerical analysis conducted for an aluminum tube with different boundary conditions and end cap configurations using MSC Nastran /Patran Software. The two end cap configurations used for the aluminum cylinders were:

1. Flat end caps
2. Dome end caps

4.1 Aluminum Tube with Flat End Cap Configuration

The three different boundary conditions applied at the ends of the aluminum tubes were:

- (i) Free-Free
- (ii) Fixed-Free
- (iii) Fixed-Translation

4.1.1 Free-Free Boundary Condition

In order to perform the numerical analysis of the aluminum tube with flat end caps, a model was developed using the MSC/Patran software with the following dimensions and material properties :

Length of the aluminum tube= 60 in, diameter of the aluminum tube= 6 in, shell thickness=0.125 in, flat end cap thickness= 0.25 in, Young's Modulus = 1×10^7 psi, Density= 0.1 lb/in^3 and Poisson's ratio=0.33. The entire model is meshed with quad4 mesh tool.

The value of the force applied from the speaker was unknown during all of the experiments. In order to obtain an approximation to the force from the speaker, a force was chosen

that matched the first peak sound pressure level for the free-free boundary condition for the aluminum tube with flat end caps. This force was then used to make comparisons between the results for the other boundary conditions which were investigated for the aluminum tube with flat end caps. Figure 4.1 shows the mesh established for the numerical analysis of the aluminum tube with flat end caps (free-free condition).

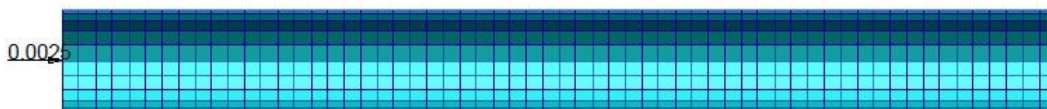

Figure 4.1: Numerical Analysis Mesh for the Aluminum Tube with Flat End Caps (Free-Free Condition)

A frequency range of 0-250 Hz was chosen for the frequency response analysis, with a force of 0.0025 lbf and a frequency resolution of 0.5 Hz. The frequency response analysis was performed using the MSC Nastran Software.

In the numerical analysis for the case of the aluminum tube with flat end caps, the starting peak that occurs in the Sound Pressure (Pa) vs Frequency (Hz) graph for Mic AFT (Figure 4.5) and Mic FWD (Figure 4.6) appears to be due to the vibration of the speaker membrane that is a part of the aluminum tube mesh. Hence, the second peak in the Sound Pressure (Pa) vs Frequency (Hz) graph should be considered the first peak for the purposes of this analysis.

Results:

Figures 4.2 and 4.3 show the results of the numerical analysis for Sound Level (dB) versus Frequency (Hz) for the AFT and FWD microphones, respectively, in an aluminum

tube with flat end caps. At 97.22 Hz, the first peak was predicted to be at a sound level of 96.670 dB at Mic AFT and 96.590 dB at Mic FWD. Figure 4.4 is a composite of Figures 4.2 and 4.3 to facilitate the comparison of the sound levels at the AFT and FWD microphones.

Figures 4.5 and 4.6 show the results of the numerical analysis for sound pressure (Pa) versus frequency for the AFT and FWD microphones, respectively, in the aluminum tube with flat ends. At 97.22 Hz, the first peak sound pressure was predicted to be 0.897 Pa at Mic AFT and 0.895 Pa at Mic FWD. Figure 4.7 is a composite of Figures 4.5 and 4.6 compares the sound pressures at the AFT and FWD microphones.

LEGEND
 — AFT: Sound Pressure Level(dB)

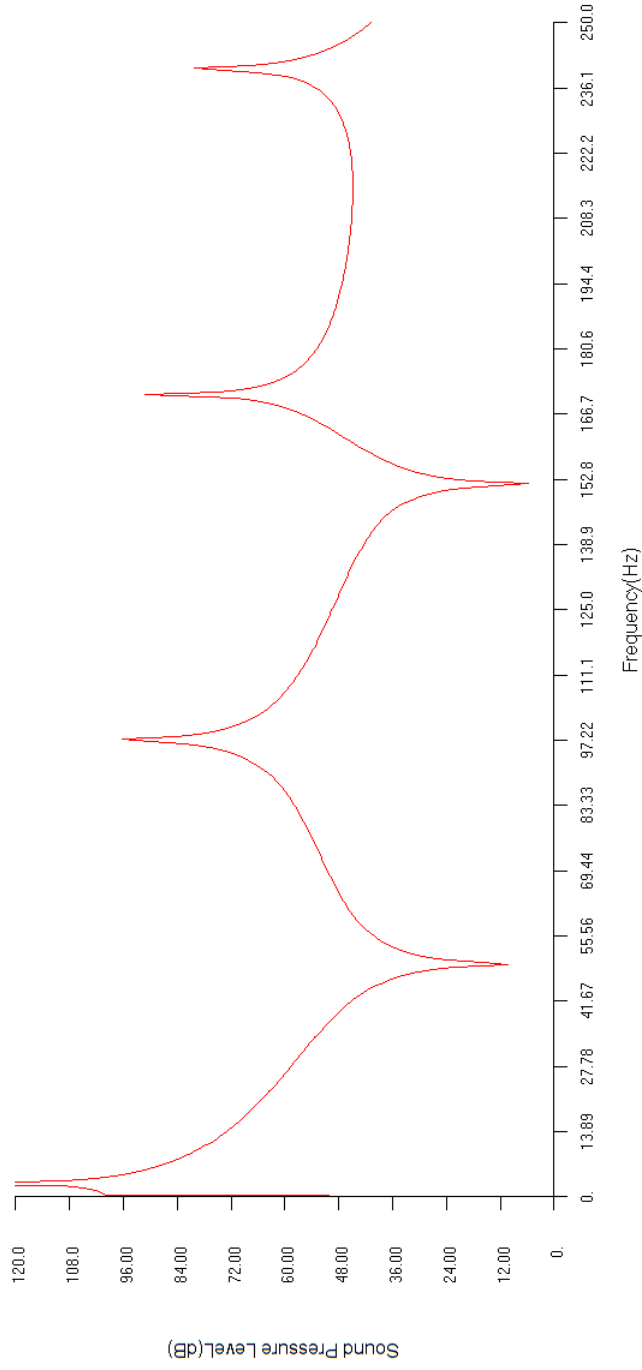

Figure 4.2: Mic AFT (dB) Vs Frequency (Hz) (Aluminum Tube with Flat End Caps, Free-Free Condition)

LEGEND
 — FWD: Sound Pressure Level(dB)

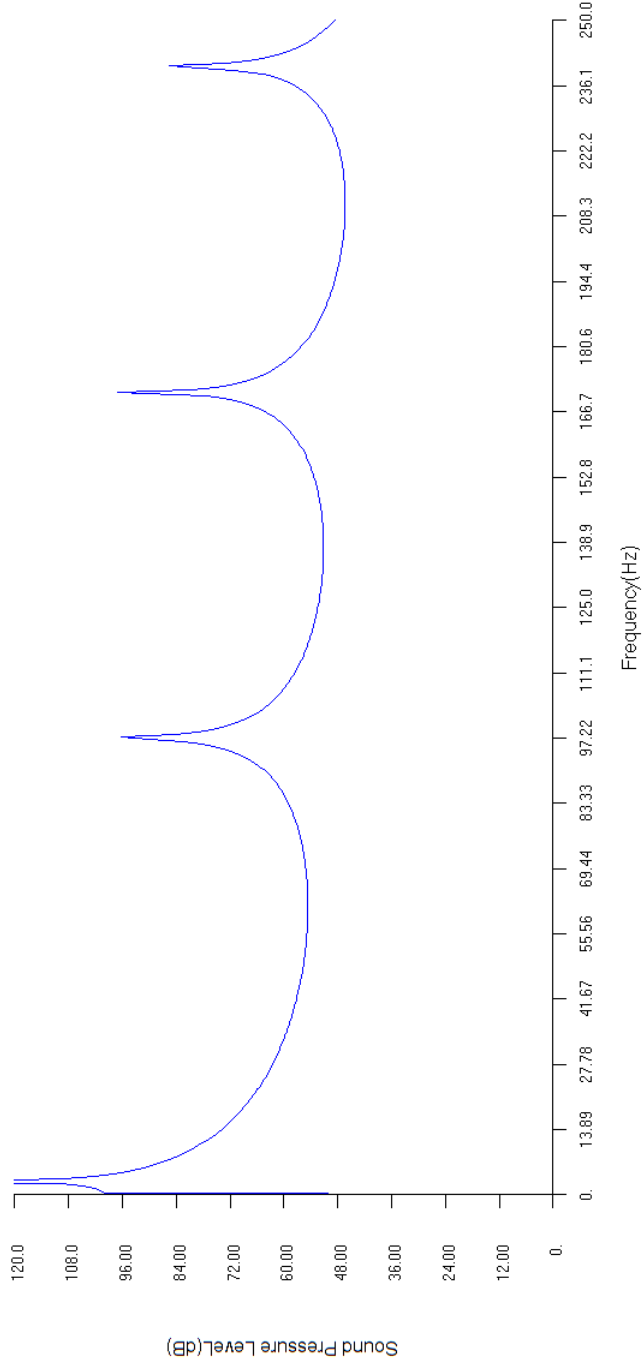

Figure 4.3: Mic FWD (dB) Vs Frequency (Hz) (Aluminum Tube with Flat End Caps, Free-Free Condition)

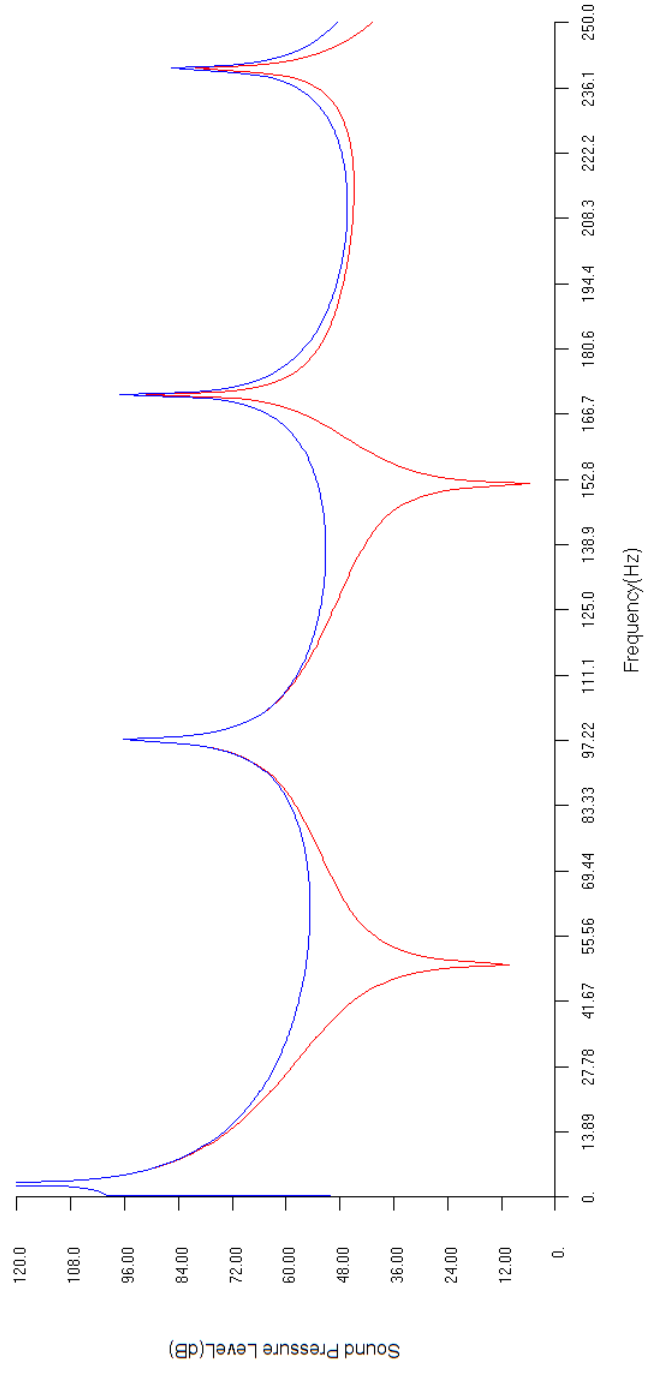

Figure 4.4: Sound Pressure Level (dB) Vs Frequency (Hz) (Aluminum Tube with Flat End Caps, Free-Free Condition)

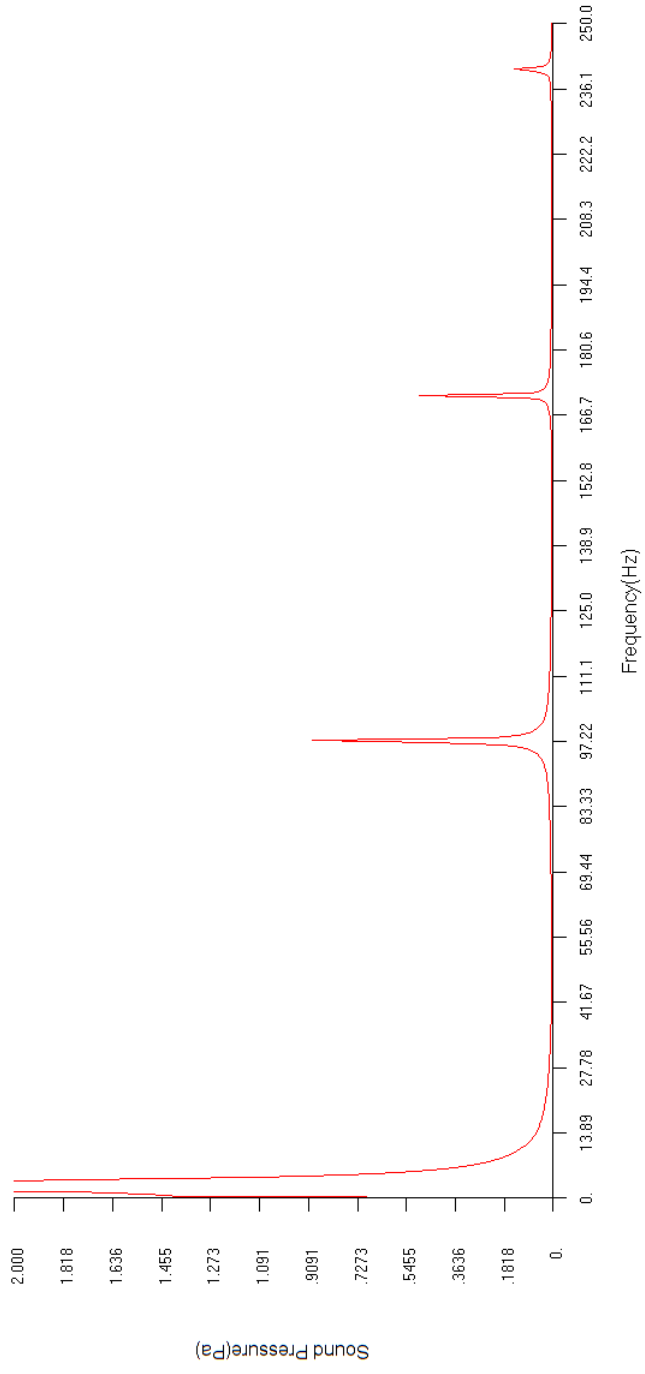

Figure 4.5: Mic AFT (Pa) Vs Frequency (Hz) (Aluminum Tube with Flat End Caps, Free-Free Condition)

LEGEND
 — FWD: Sound Pressure(Pa)

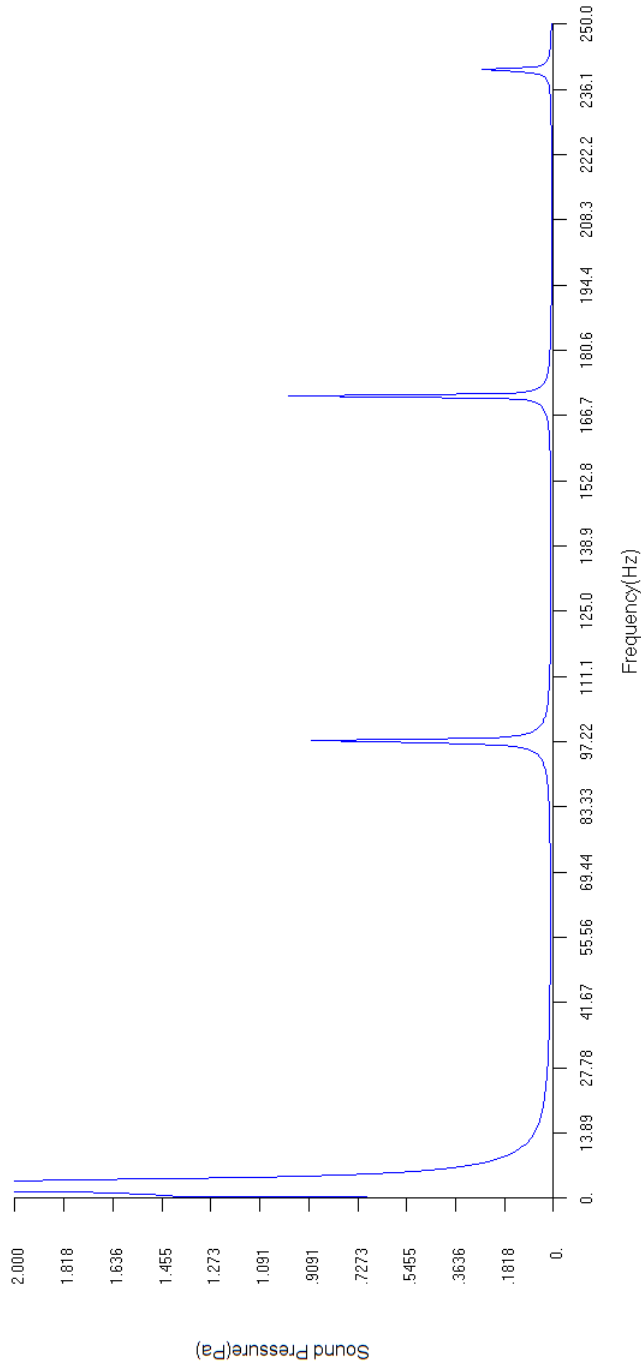

Figure 4.6: Mic FWD (Pa) Vs Frequency (Hz) (Aluminum Tube with Flat End Caps, Free-Free Condition)

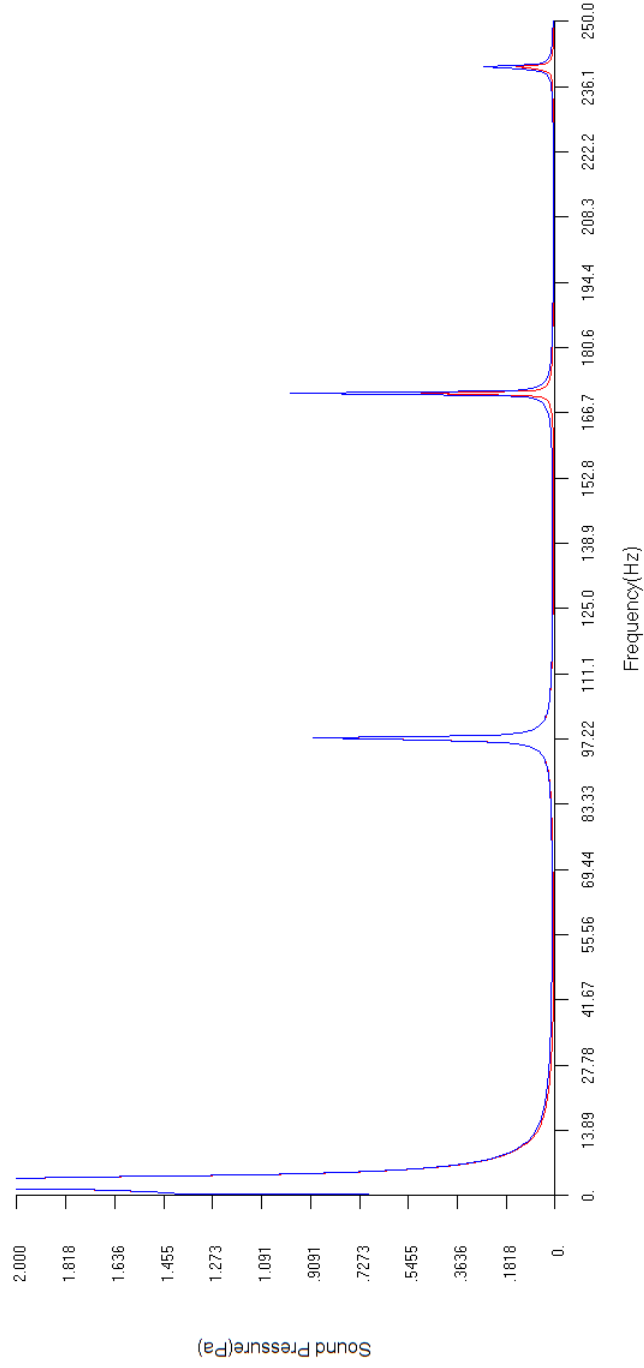

Figure 4.7: Sound Pressure (Pa) Vs Frequency (Hz) (Aluminum Tube with Flat End Caps, Free-Free Condition)

Summary of Results

Table 4.1 shows the results of the numerical analysis of the aluminum tube with flat end caps (Free-Free Condition) using acoustic excitation.

Aluminum Tube with Flat End Caps using Acoustic Excitation		
	Numerical Results	
	Sound Pressure Level(dB)	Sound Pressure (Pa)
Free-Free Condition	96.67 dB at 97.22 Hz (Mic AFT)	0.897 Pa at 97.22 Hz (Mic AFT)
	96.59 dB at 97.22 Hz (Mic FWD)	0.895 Pa at 97.22 Hz (Mic FWD)

Table 4.1: Results of the Numerical Simulation for the Aluminum Tube with Flat End Caps (Free-Free Condition) using Acoustic Excitation

4.1.2 Fixed-Free Boundary Condition

Figure 4.8 shows the mesh established for the numerical analysis of the aluminum tube with flat end caps (Fixed-Free Condition).

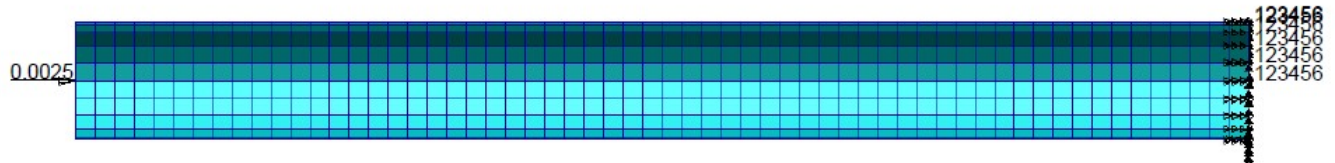

Figure 4.8: Numerical Analysis Setup of Aluminum Tube with Flat End Caps (Fixed-Free Condition)

Results:

Figures 4.9 and 4.10 show the results of the numerical model for sound level (dB) versus frequency for the AFT and FWD microphones, respectively, in an aluminum tube with flat ends. At 97.22 Hz, the first peak was predicted to be at a sound level of 98.46 dB at Mic AFT and 98.42 dB at Mic FWD. Figure 4.11 is a composite of Figures 4.9 and 4.10 to facilitate the comparison of the sound levels at the AFT and FWD microphones.

Figures 4.12 and 4.13 show the results of the numerical model for sound pressure (Pa) versus frequency for the AFT and FWD microphones, respectively, in an aluminum tube with flat ends. At 97.22 Hz, the first peak sound pressure was predicted to be 1.138 Pa at Mic AFT and 1.136 Pa at Mic FWD. Figure 4.21 is a composite graph of Figures 4.12 and 4.13 that compares the sound pressures at the AFT and FWD microphones.

LEGEND
 — AFT: Sound Pressure Level(dB)

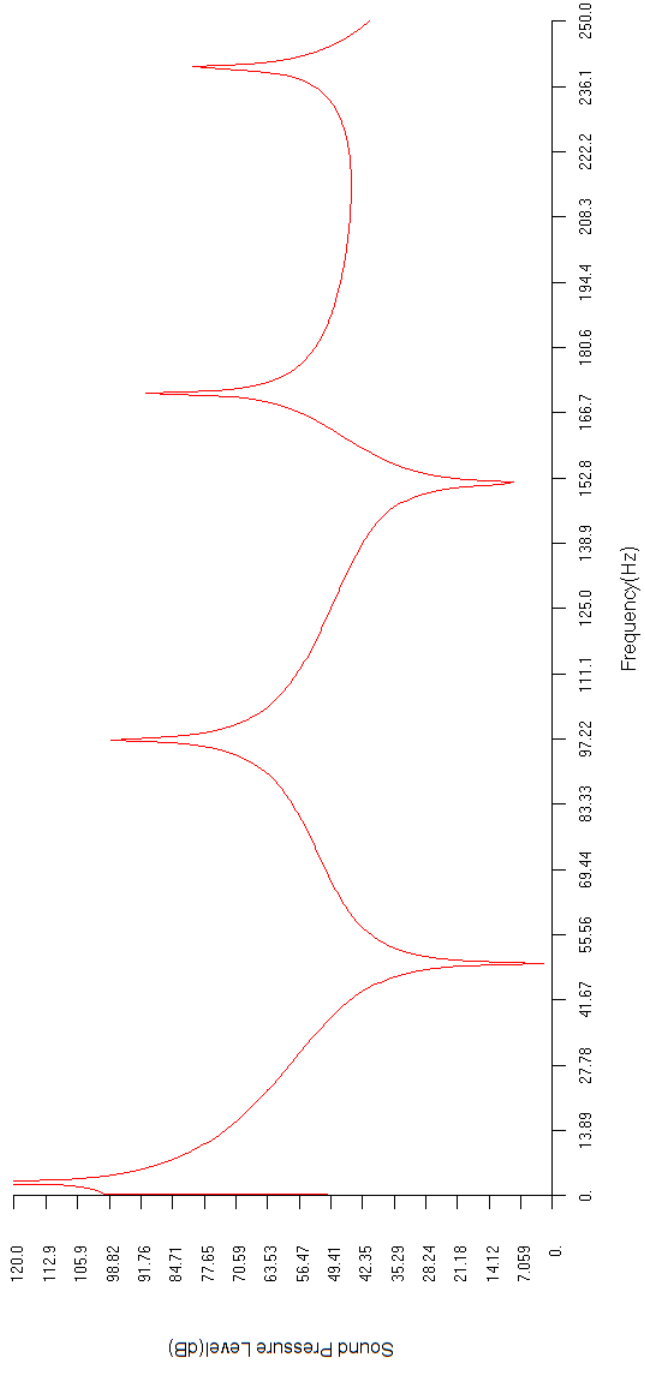

Figure 4.9: Mic AFT (dB) Vs Frequency (Hz) (Aluminum Tube with Flat End Caps, Fixed-Free Condition)

LEGEND
 FWD: Sound Pressure Level(dB)

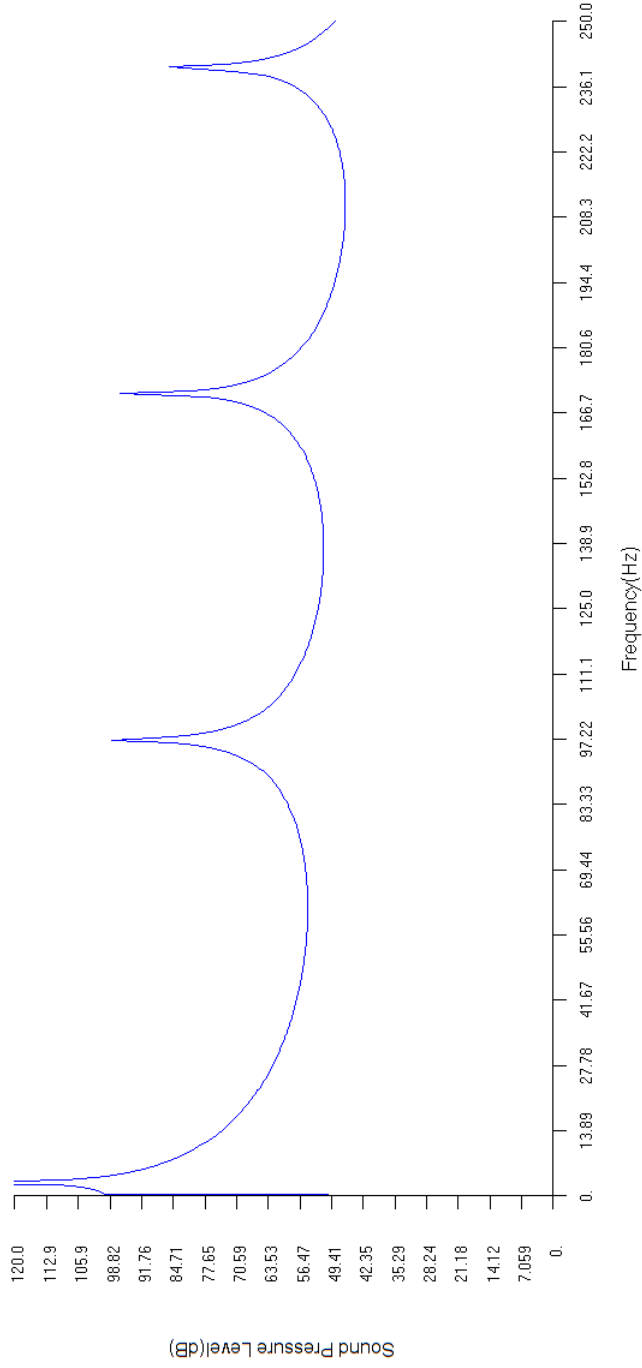

Figure 4.10: Mic FWD (dB) Vs Frequency (Hz) (Aluminum Tube with Flat End Caps, Fixed-Free Condition)

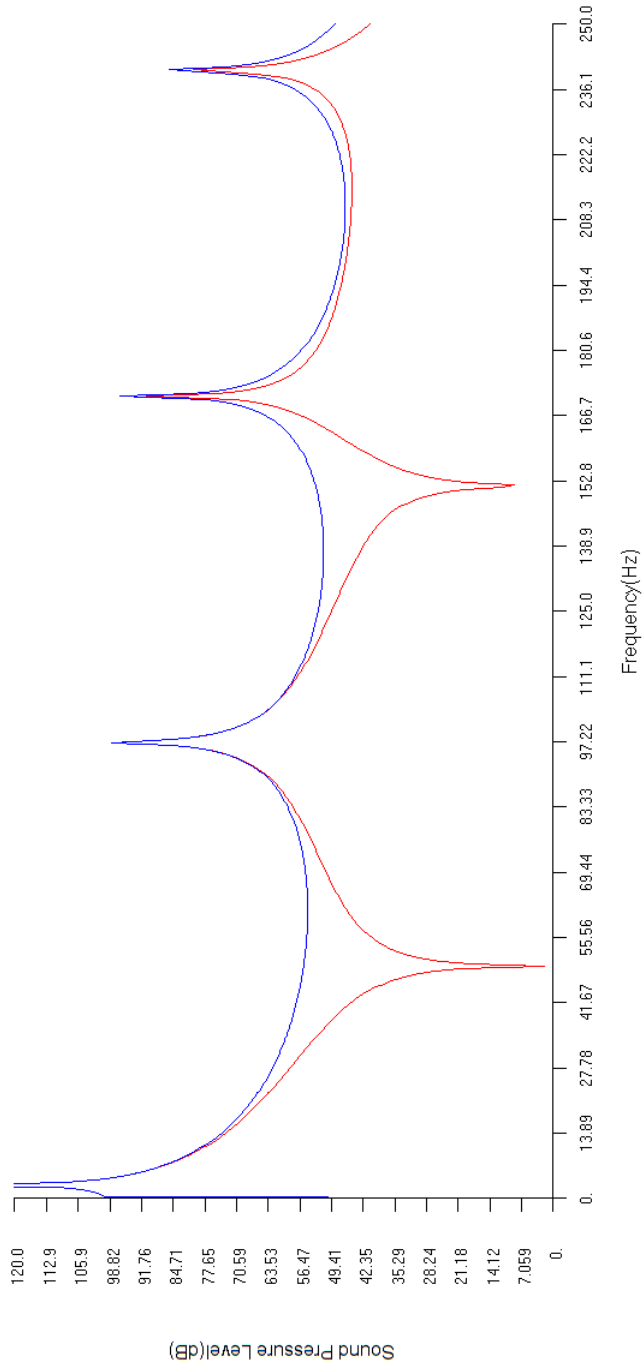

Figure 4.11: Sound Pressure Level (dB) Vs Frequency (Hz) (Aluminum Tube with Flat End Caps, Fixed-Free Condition)

LEGEND
 — AFT: Sound Pressure(Pa)

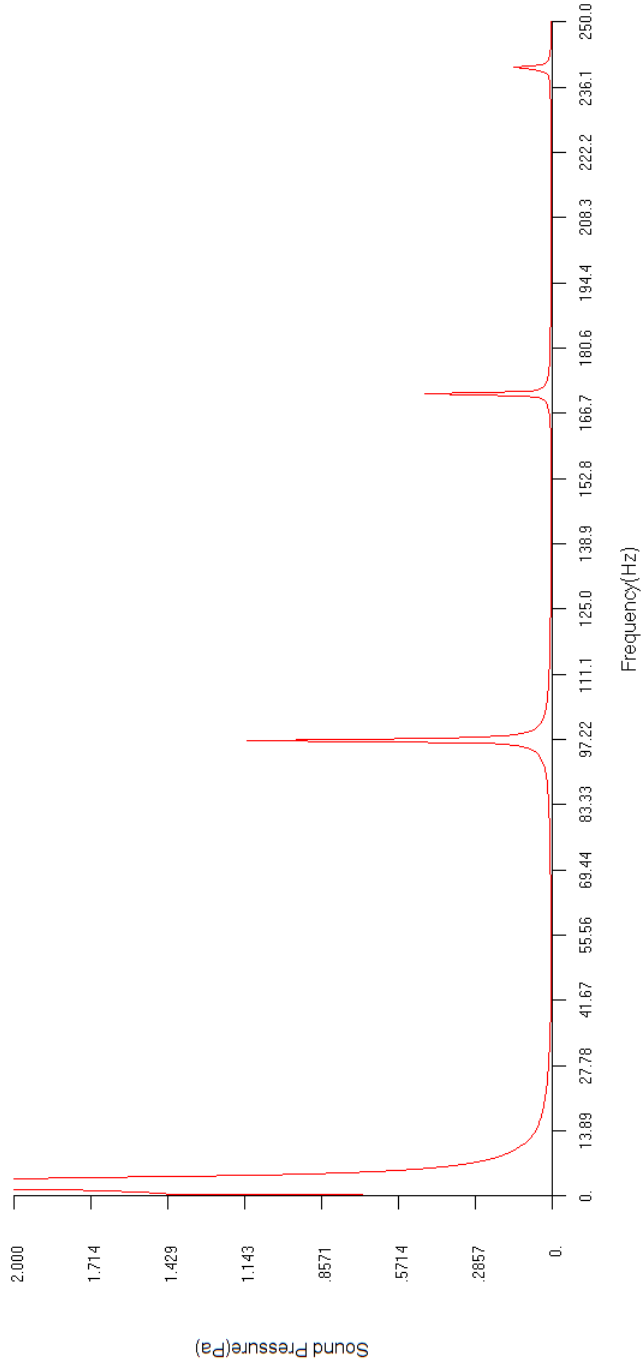

Figure 4.12: Mic AFT (Pa) Vs Frequency (Hz) (Aluminum Tube with Flat End Caps, Fixed-Free Condition)

LEGEND
— FWD: Sound Pressure(Pa)

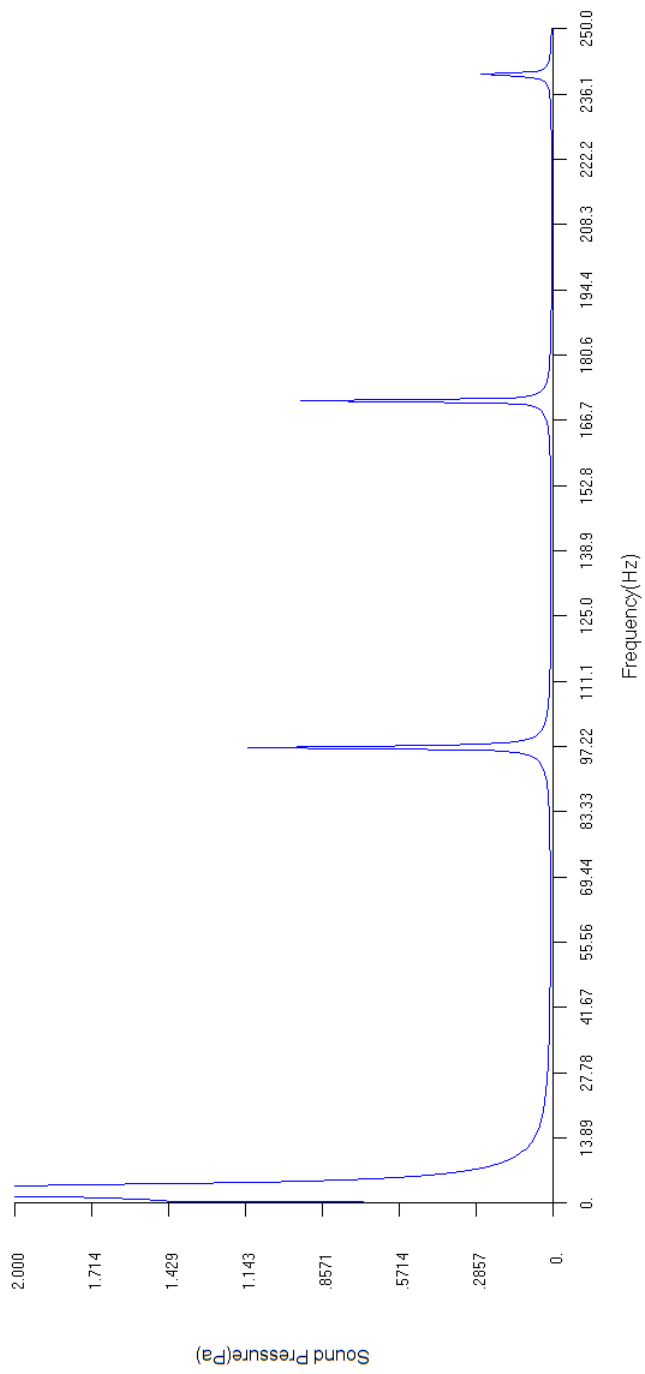

Figure 4.13: Mic FWD (Pa) Vs Frequency (Hz) (Aluminum Tube with Flat End Caps, Fixed-Free Condition)

LEGEND
 AFT: Sound Pressure(Pa)
 FWD: Sound Pressure(Pa)

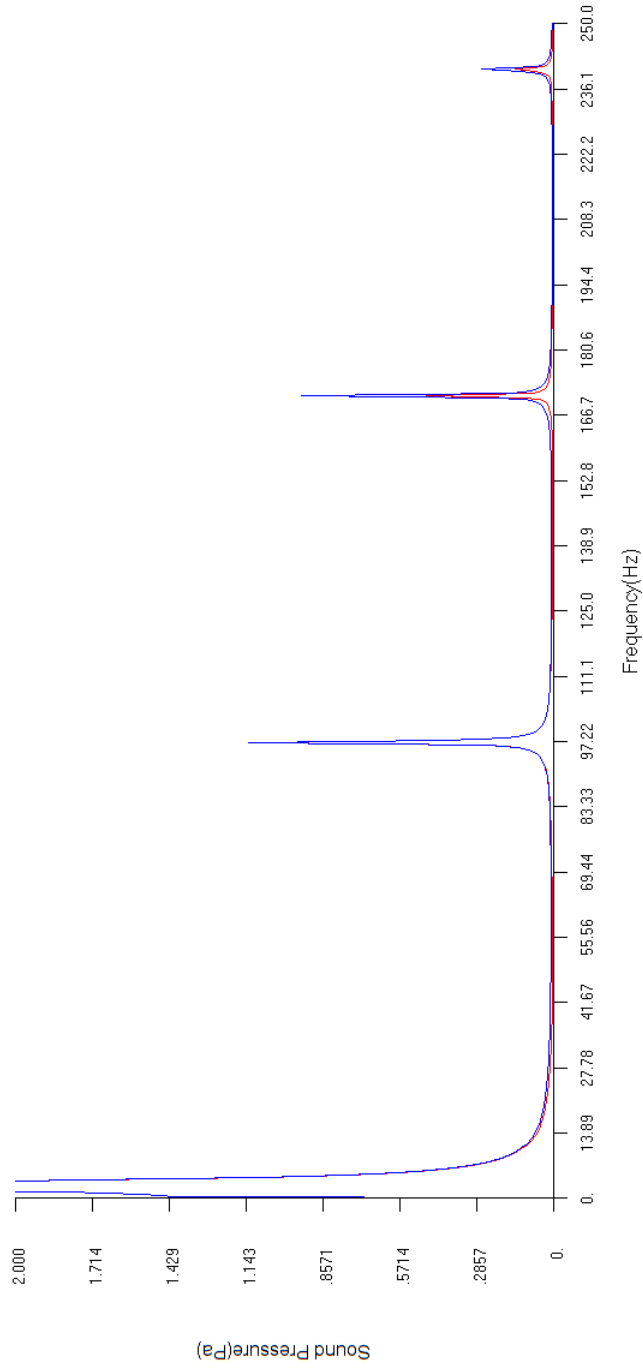

Figure 4.14: Sound Pressure (Pa) Vs Frequency (Hz) (Aluminum Tube with Flat End Caps, Fixed-Free Condition)

Summary of Results

Table 4.2 presents the results of numerical analysis of the aluminum tube with flat end caps (Fixed-Free Condition) using acoustic excitation.

Aluminum Tube with Flat End Caps using Acoustic Excitation		
	Numerical Results	
	Sound Pressure Level(dB)	Sound Pressure (Pa)
Fixed-Free Condition	98.46 dB at 97.22 Hz (Mic AFT)	1.138 Pa at 97.22 Hz (Mic AFT)
	98.42 dB at 97.22 Hz (Mic FWD)	1.136 Pa at 97.22 Hz (Mic FWD)

Table 4.2: Results of the Numerical Simulation for the Aluminum Tube with Flat End Caps (Fixed-Free Condition) using Acoustic Excitation

4.1.3 Fixed-Translation Boundary Condition

Figure 4.15 shows the mesh used for the numerical analysis of the aluminum tube with Flat end caps (Fixed-Translation Condition).

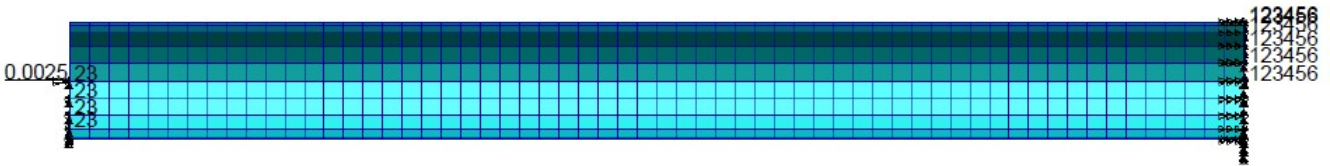

Figure 4.15: Mesh used for the Numerical Analysis of the Aluminum Tube with Flat End Caps (Fixed- Translation Condition)

Results:

Figures 4.16 and 4.17 show the results of the numerical analysis for Sound Level (dB) versus Frequency (Hz) predicted at the AFT and FWD microphones, respectively, in an aluminum tube with flat ends. At 97.22 Hz, the first peak was at a sound level of 98.25dB at Mic AFT and 98.21 dB at Mic FWD. Figure 4.18 is a composite of Figures 4.16 and 4.17 to facilitate the comparison of the predicted sound levels at the AFT and FWD microphones.

Figures 4.19 and 4.20 show the results of the numerical analysis for Sound Pressure (Pa) versus Frequency (Hz) predicted at the AFT and FWD microphones, respectively, in an aluminum tube with flat ends. At 97.22 Hz, the first peak sound pressure was predicted to be at 1.131 Pa at Mic AFT and 1.128 Pa at Mic FWD. Figure 4.21 is a composite of Figures 4.19 and 4.20 that compares the sound pressures at the AFT and FWD microphones.

LEGEND
 — AFT: Sound Pressure Level(dB)

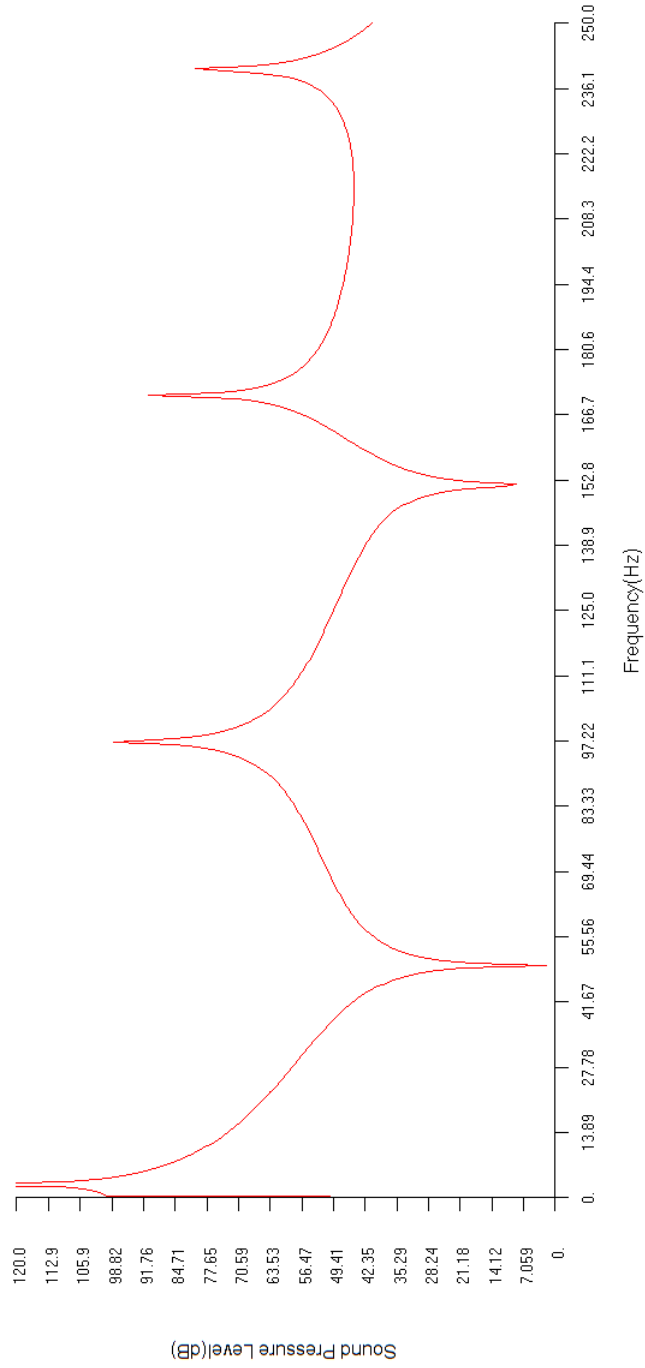

Figure 4.16: Mic AFT (dB) Vs Frequency (Hz) (Aluminum Tube with Flat End Caps, Fixed-Translation Condition)

LEGEND
 FWD: Sound Pressure Level(dB)

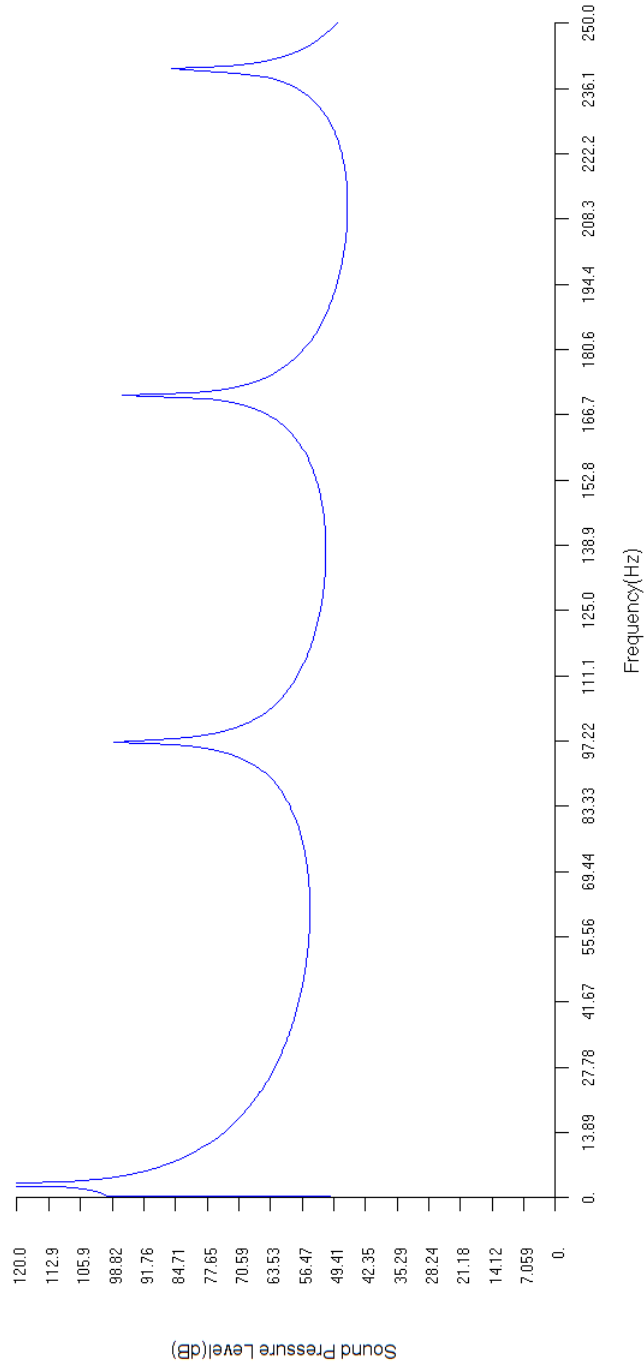

Figure 4.17: Mic FWD (dB) Vs Frequency (Hz) (Aluminum Tube with Flat End Caps, Fixed-Translation Condition)

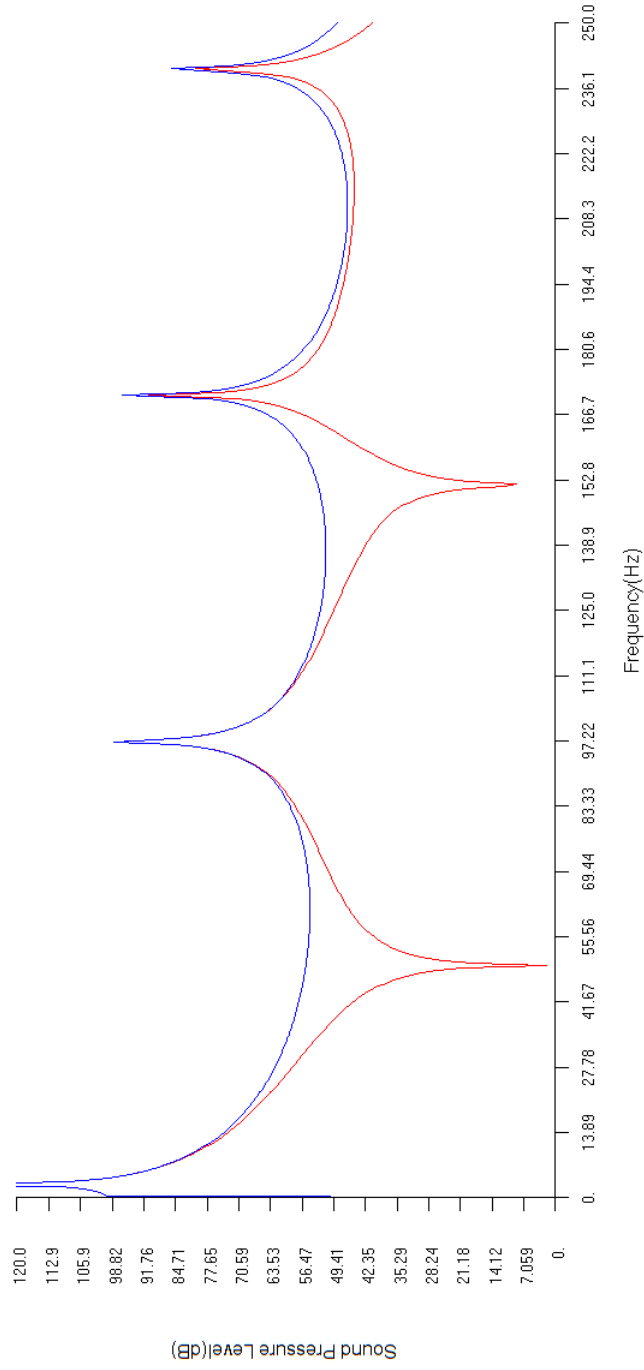

Figure 4.18: Sound Pressure Level (dB) Vs Frequency (Hz) (Aluminum Tube with Flat End Caps, Fixed-Translation Condition)

LEGEND
 — AFT: Sound Pressure(Pa)

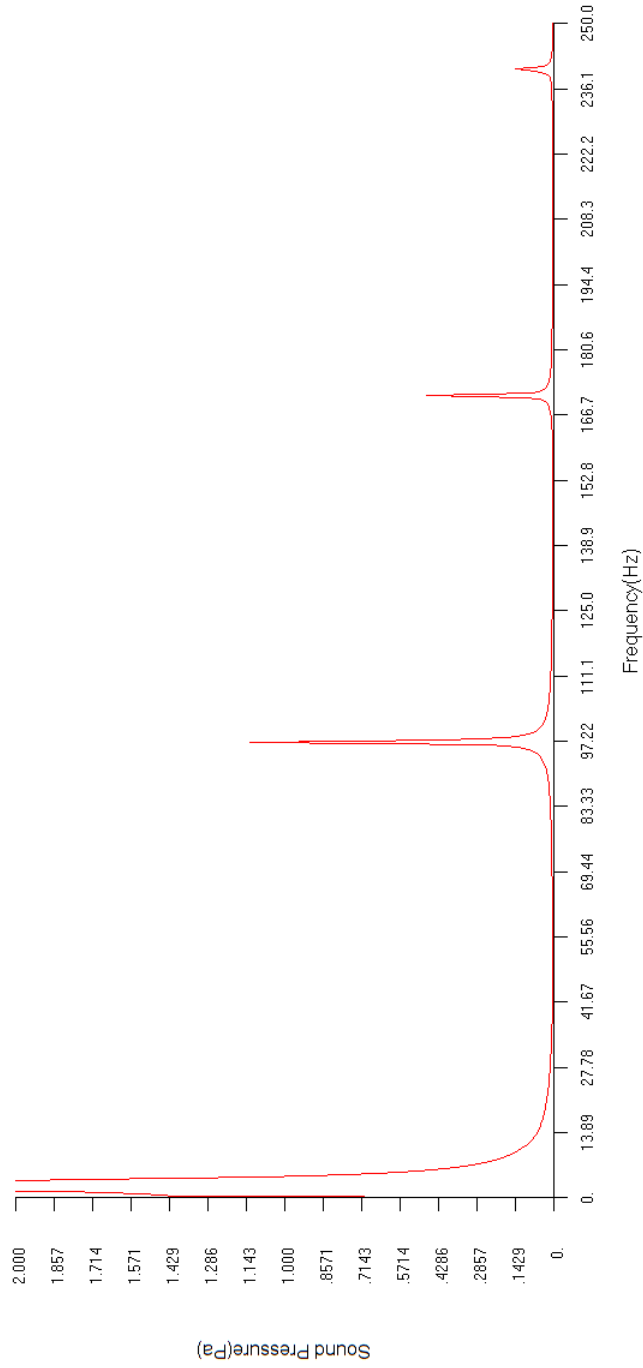

Figure 4.19: Mic AFT (Pa) Vs Frequency (Hz) (Aluminum Tube with Flat End Caps, Fixed-Translation Condition)

LEGEND
 FWD: Sound Pressure(Pa)

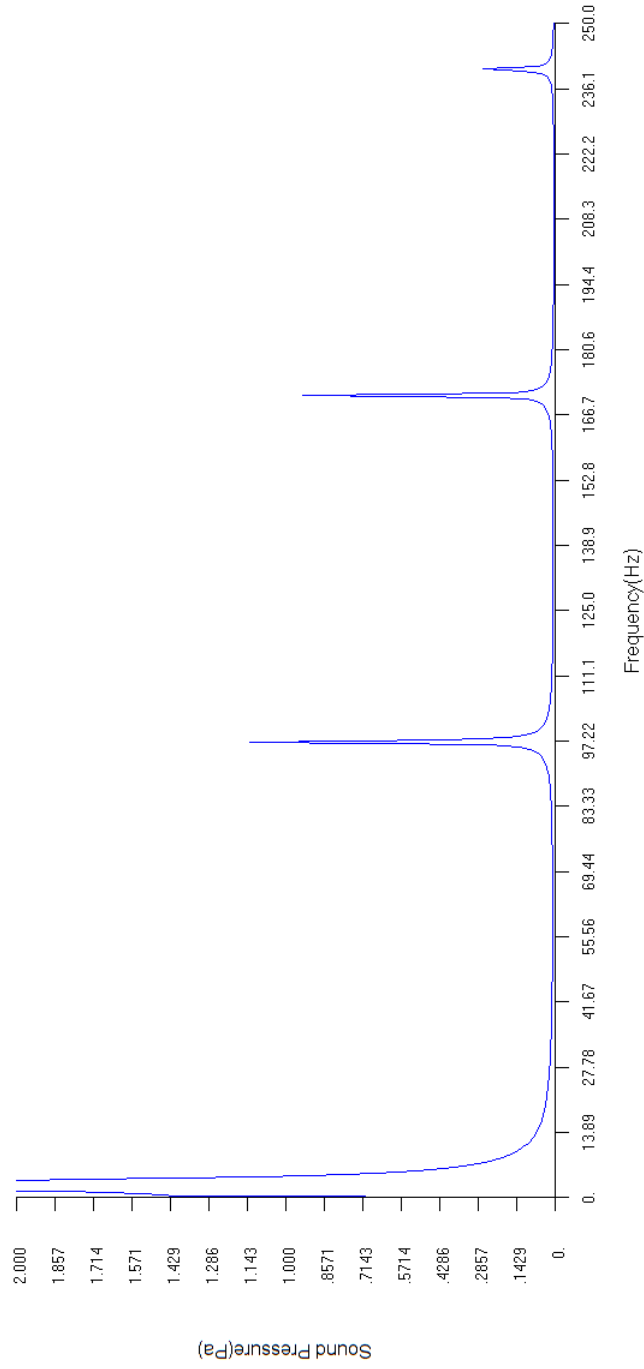

Figure 4.20: Mic FWD (Pa) Vs Frequency (Hz) (Aluminum Tube with Flat End Caps, Fixed-Translation Condition)

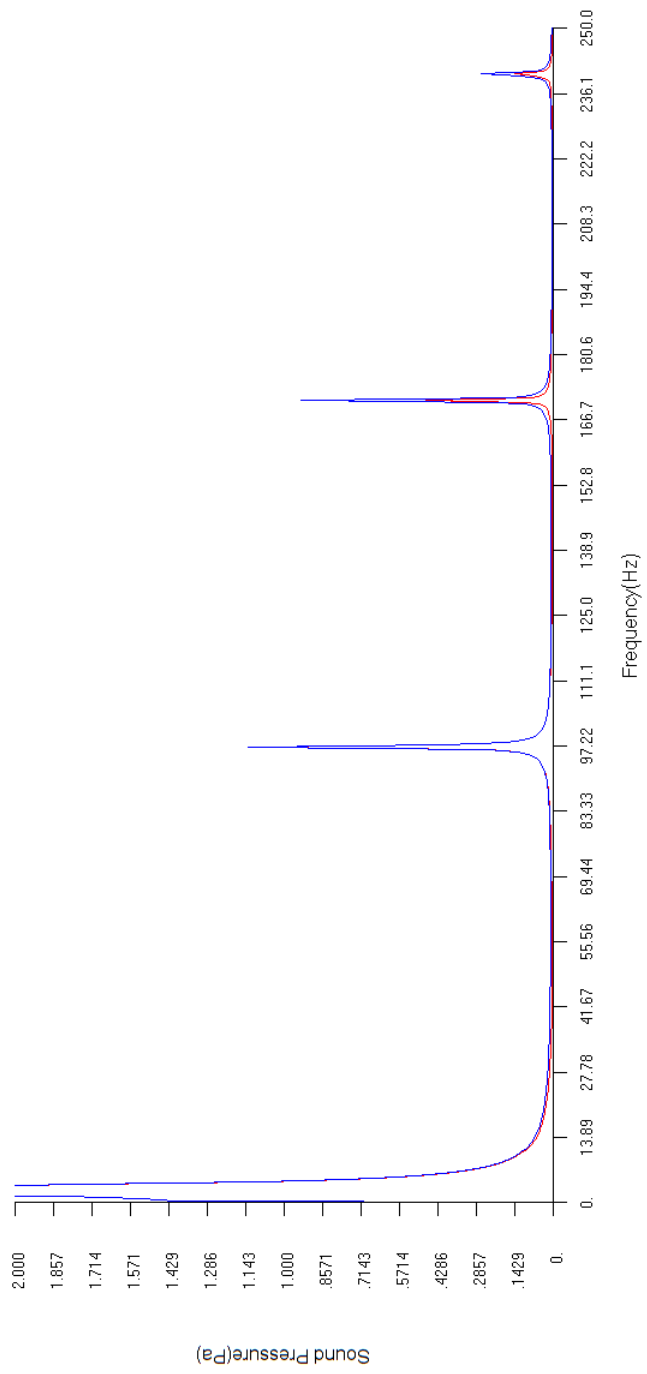

Figure 4.21: Sound Pressure (Pa) Vs Frequency (Hz) (Aluminum Tube with Flat End Caps, Fixed-Translation Condition)

Summary of Results

Table 4.3 gives the results of the numerical analysis of the aluminum tube with flat end caps (Fixed-Translation Condition) using acoustic excitation.

Aluminum Tube with Flat End Caps using Acoustic Excitation		
	Numerical Results	
	Sound Pressure Level(dB)	Sound Pressure (Pa)
Fixed-Translation Condition	98.30 dB at 97.22 Hz (Mic AFT)	1.131 Pa at 97.22 Hz (Mic AFT)
	98.25 dB at 97.22 Hz (Mic FWD)	1.128 Pa at 97.22 Hz (Mic FWD)

Table 4.3: Results of the Numerical Analysis of an Aluminum Tube with Flat End Caps (Fixed-Translation Condition) using Acoustic Excitation

4.2 Aluminum Tube with Dome End Cap Configuration

The three different boundary conditions applied at the ends of the aluminum tubes were:

- (i) Free-Free
- (ii) Fixed-Free
- (iii) Fixed-Translation

4.2.1 Free-Free Boundary Condition

In order to perform the numerical analysis of the aluminum tube with dome end caps, the model was developed in the MSC Patran software with the following dimensions and material properties:

Length of the aluminum tube= 60 in, diameter of the aluminum tube= 6 in, shell thickness= 0.125 in, dome end cap thickness= 0.25 in, Young's Modulus = 1×10^7 psi, Density= 0.1 lb/in^3 and Poisson's ratio= 0.33 .The entire model is meshed with quad4 mesh tool.

The value of the force applied from the speaker was unknown during all of the experiments. In order to obtain an approximation to the force from the speaker, a force was chosen that matched the first peak sound pressure level for the free-free boundary condition for the aluminum tube with dome end caps. The value of this force was different from the one used for the aluminum tube with flat end caps discussed in the Section 4.1.1. This force was then used to make comparisons between the results for the other boundary conditions which were investigated for the aluminum tube with dome end caps. Figure 4.22 shows the mesh used for the numerical analysis of the aluminum tube with dome end caps (free-free Condition)

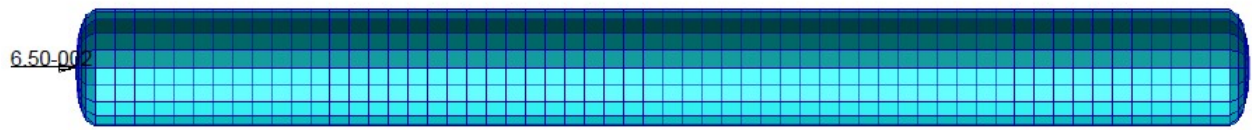

Figure 4.22: Numerical Analysis Mesh for the Aluminum Tube with Dome End Caps (Free-Free Condition)

A frequency range of 0-250 Hz was chosen for the frequency response analysis, with a force of 0.065 lbf and a frequency resolution of 0.5 Hz. The frequency response analysis was performed using the MSC Nastran Software.

In the numerical analysis for the case of the aluminum tube with dome end caps, the starting peak that occurs in the Sound Pressure (Pa) vs Frequency (Hz) graph for Mic AFT (Figure 4.26) and Mic FWD (Figure 4.27) appears to be due to the vibration of the speaker membrane that is a part of the aluminum tube mesh. Hence, the second peak in the Sound Pressure (Pa) vs Frequency (Hz) graph should be considered the first peak for the purposes of this analysis.

Results:

Figures 4.23 and 4.24 show the results of the numerical analysis for sound level (dB) versus frequency for the AFT and FWD microphones, respectively, in an aluminum tube with dome ends. At 109.5 Hz, the first peak was predicted to be at a sound level of 104.00 dB at Mic AFT and 104.00 dB at Mic FWD. Figure 4.25 is a composite of Figures 4.23 and 4.24 to facilitate the comparison of the predicted sound levels at the AFT and FWD microphones.

Figures 4.26 and 4.27 show the results of the numerical analysis for sound pressure (Pa) versus frequency for the AFT and FWD microphones, respectively, in an aluminum tube with dome ends. At 109.5 Hz, the first peak pressure is predicted to be 2.142 Pa at Mic AFT and 2.142 Pa at Mic FWD. Figure 4.28 is a composite of Figures 4.26 and 4.27 that compares the sound pressures expected at the AFT and FWD microphones.

LEGEND
 — AFT: Sound Pressure Level(dB)

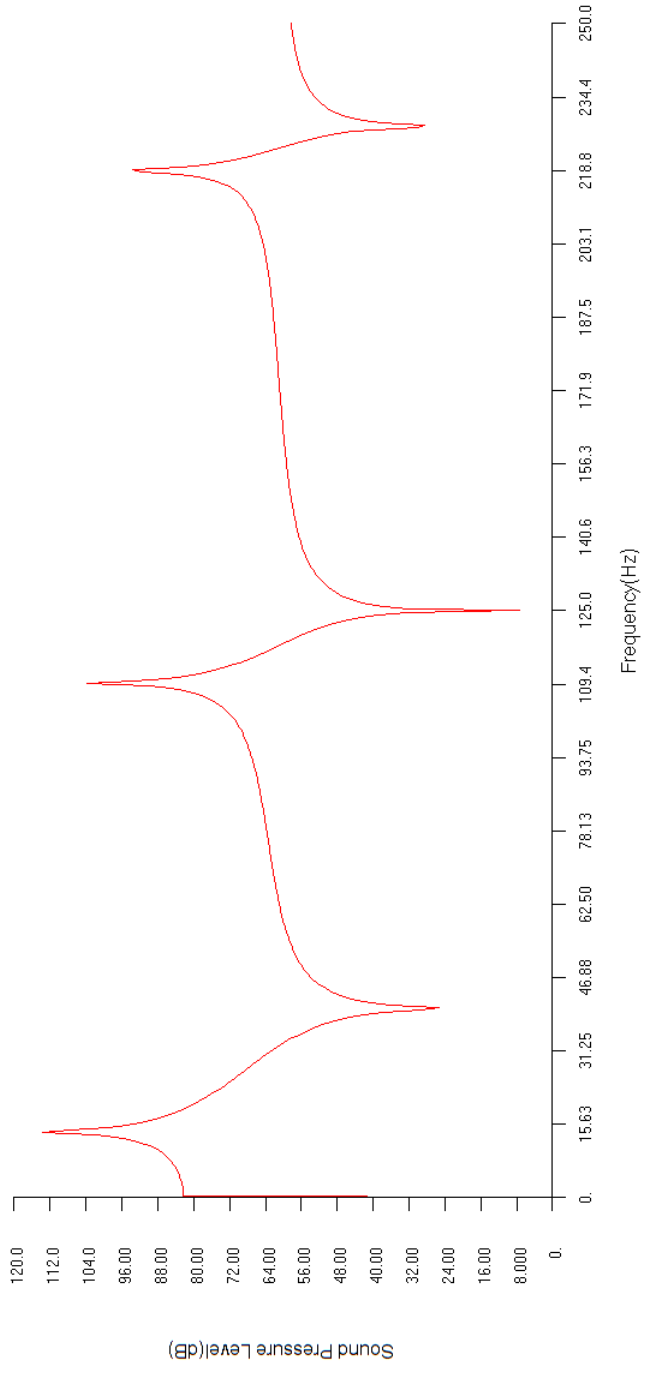

Figure 4.23: Mic AFT (dB) Vs Frequency (Hz) (Aluminum Tube with Dome End Caps, Free-Free Condition)

LEGEND
 — FWD: Sound Pressure Level(dB)

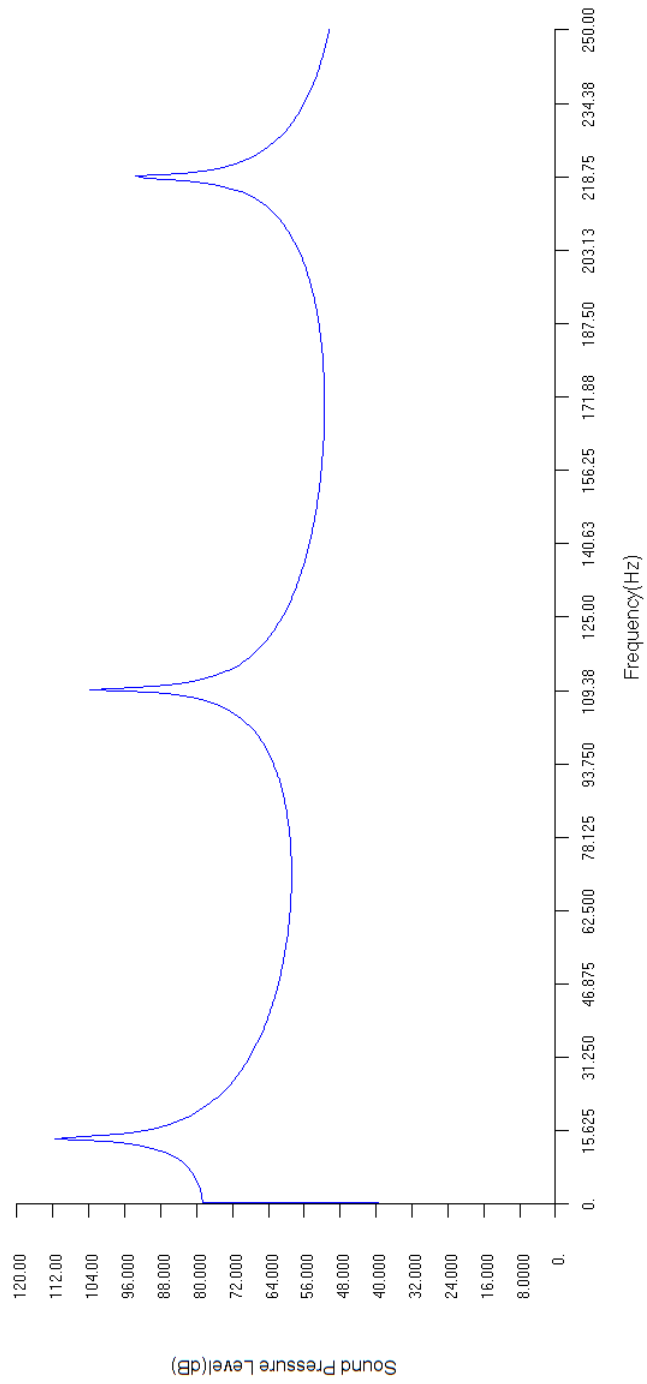

Figure 4.24: Mic FWD (dB) Vs Frequency (Hz) (Aluminum Tube with Dome End Caps, Free-Free Condition)

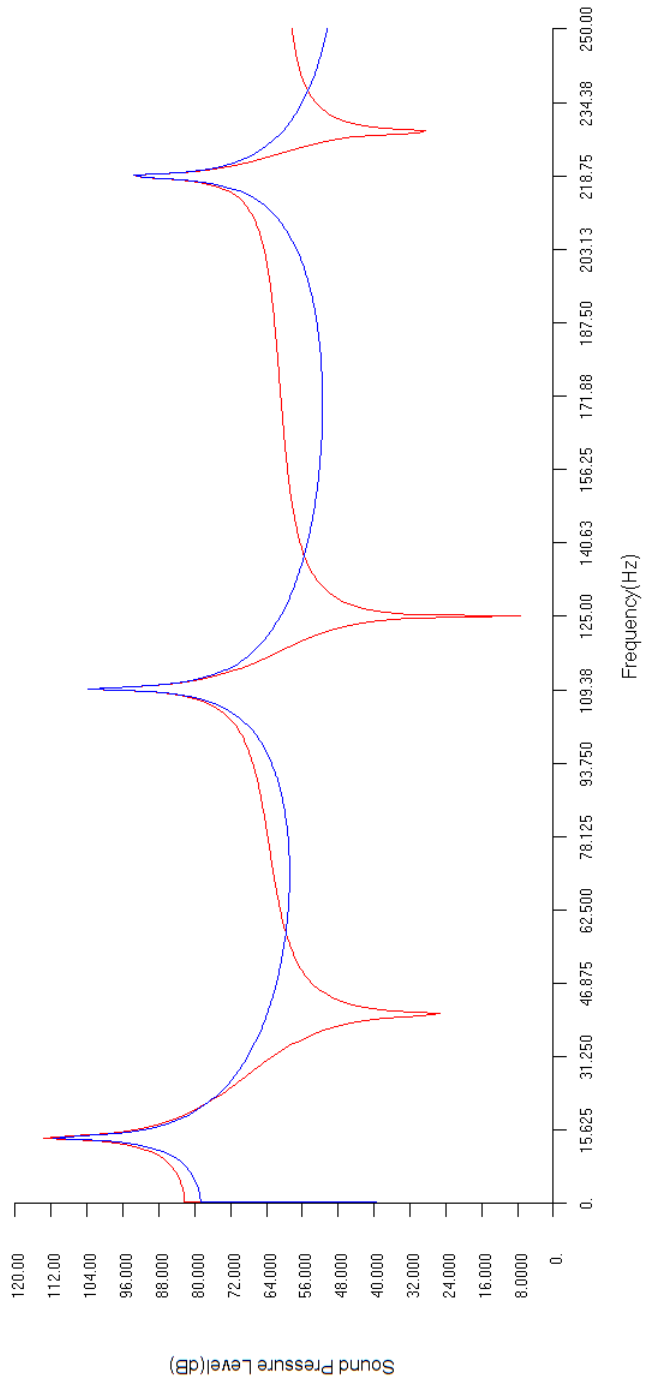

Figure 4.25: Sound Pressure Level (dB) Vs Frequency (Hz) (Aluminum Tube with Dome End Caps, Free-Free Condition)

LEGEND
 — AFT: Sound Pressure (Pa)

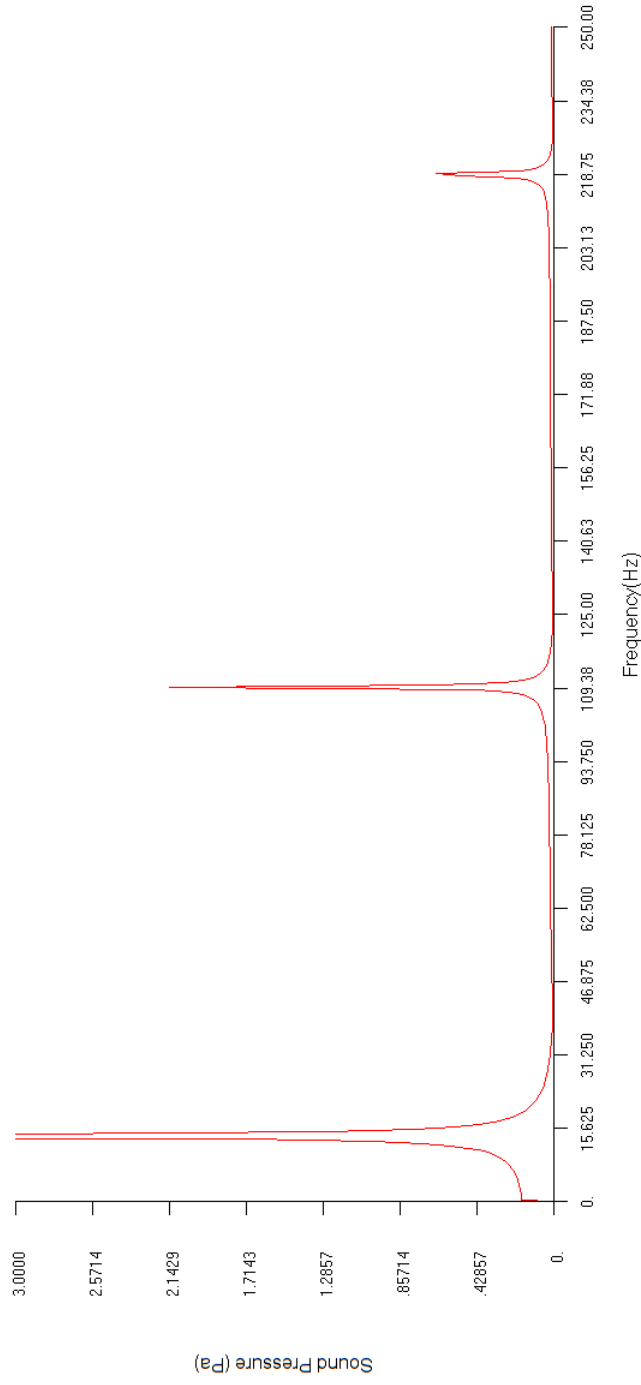

Figure 4.26: Mic AFT (Pa) Vs Frequency (Hz) (Aluminum Tube with Dome End Caps, Free-Free Condition)

LEGEND
 FWD: Sound Pressure (Pa)

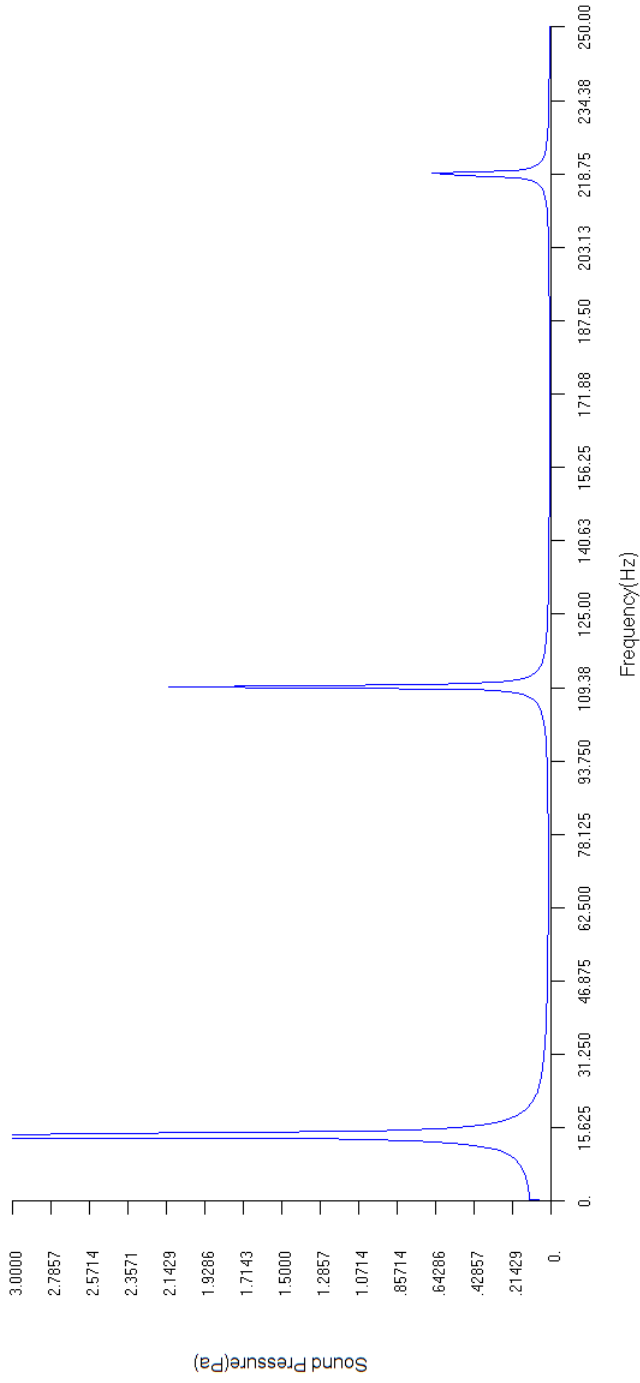

Figure 4.27: Mic FWD (Pa) Vs Frequency (Hz) (Aluminum Tube with Dome End Caps, Free-Free Condition)

LEGEND
 AFT: Sound Pressure(Pa)
 FWD: Sound Pressure(Pa)

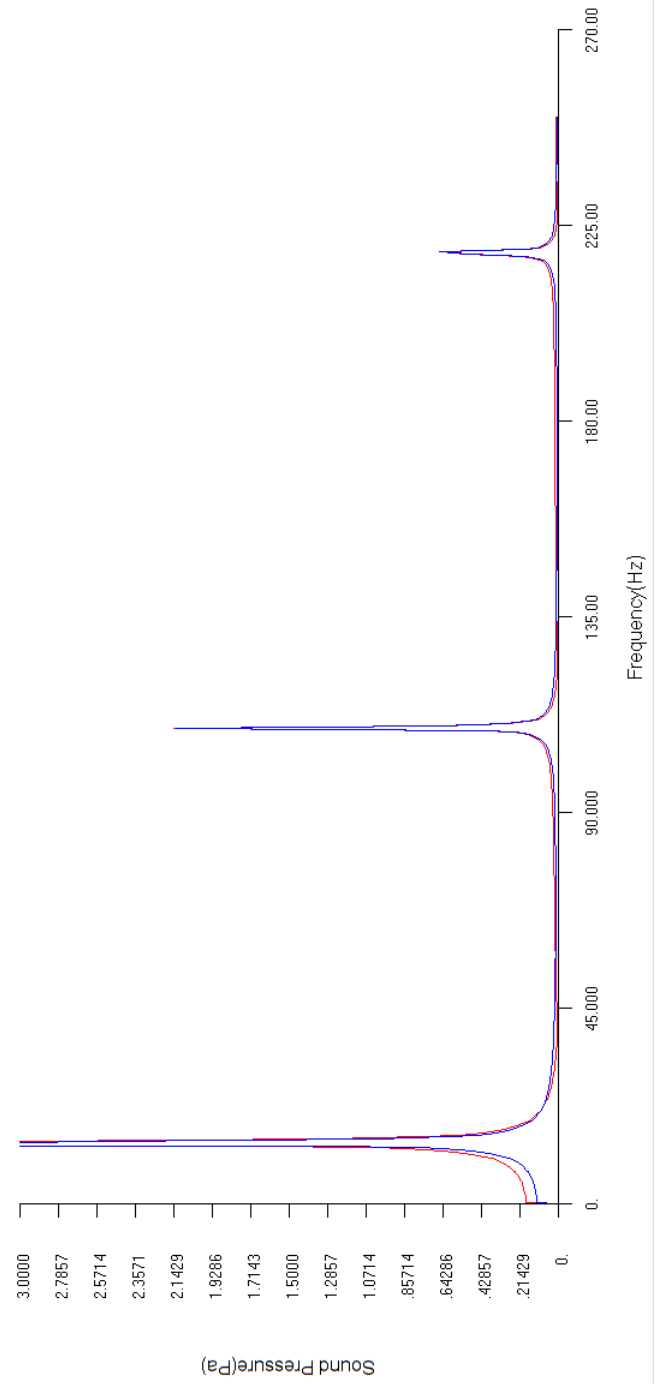

Figure 4.28: Sound Pressure (Pa) Vs Frequency (Hz) (Aluminum Tube with Dome End Caps, Free-Free Condition)

Summary of Results

Table 4.4 shows the results of the numerical analysis for an aluminum tube with dome end caps (Free-Free Condition) using acoustic excitation.

Aluminum Tube with Dome End Caps using Acoustic Excitation		
	Numerical Results	
	Sound Pressure Level(dB)	Sound Pressure (Pa)
Free-Free Condition	104.00 dB at 109.5 Hz (Mic AFT)	2.142 Pa at 109.5 Hz (Mic AFT)
	104.00 dB at 109.5 Hz (Mic FWD)	2.142 Pa at 109.5 Hz (Mic FWD)

Table 4.4: Numerical Results of Aluminum Tube with Dome End Caps (Free-Free Condition) using Acoustic Excitation

4.2.2 Fixed-Free Boundary Condition

Figure 4.29 shows the mesh used for the numerical analysis of an aluminum tube with dome end caps (Fixed-Free Condition)

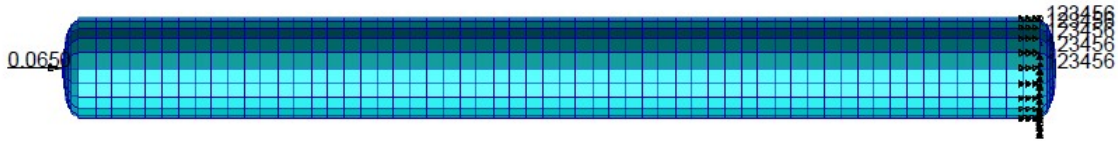

Figure 4.29: Numerical Analysis Mesh for an Aluminum Tube with Dome End Caps (Fixed-Free Condition)

Results:

Figures 4.30 and 4.31 show the results of the numerical analysis for sound level (dB) versus frequency at the AFT and FWD microphones, respectively, in an aluminum tube with dome ends. At 109.5 Hz, the first peak is predicted to be at a sound level of 104.52 dB at Mic AFT and 105.00 dB at Mic FWD. Figure 4.32 is a composite of Figures 4.30 and 4.31 to facilitate the comparison of the sound levels at the AFT and FWD microphones.

Figures 4.33 and 4.34 show the results of the numerical analysis for sound pressure (Pa) versus frequency at the AFT and FWD microphones, respectively, in an aluminum tube with dome ends. At 109.5 Hz, the first peak sound pressure is predicted to be at 2.368 Pa at Mic AFT and 2.375 Pa at Mic FWD. Figure 4.35 is a composite of Figures 4.33 and 4.34 to compare the sound pressures at the AFT and FWD microphones.

LEGEND
— AFT: Sound Pressure Level (dB)

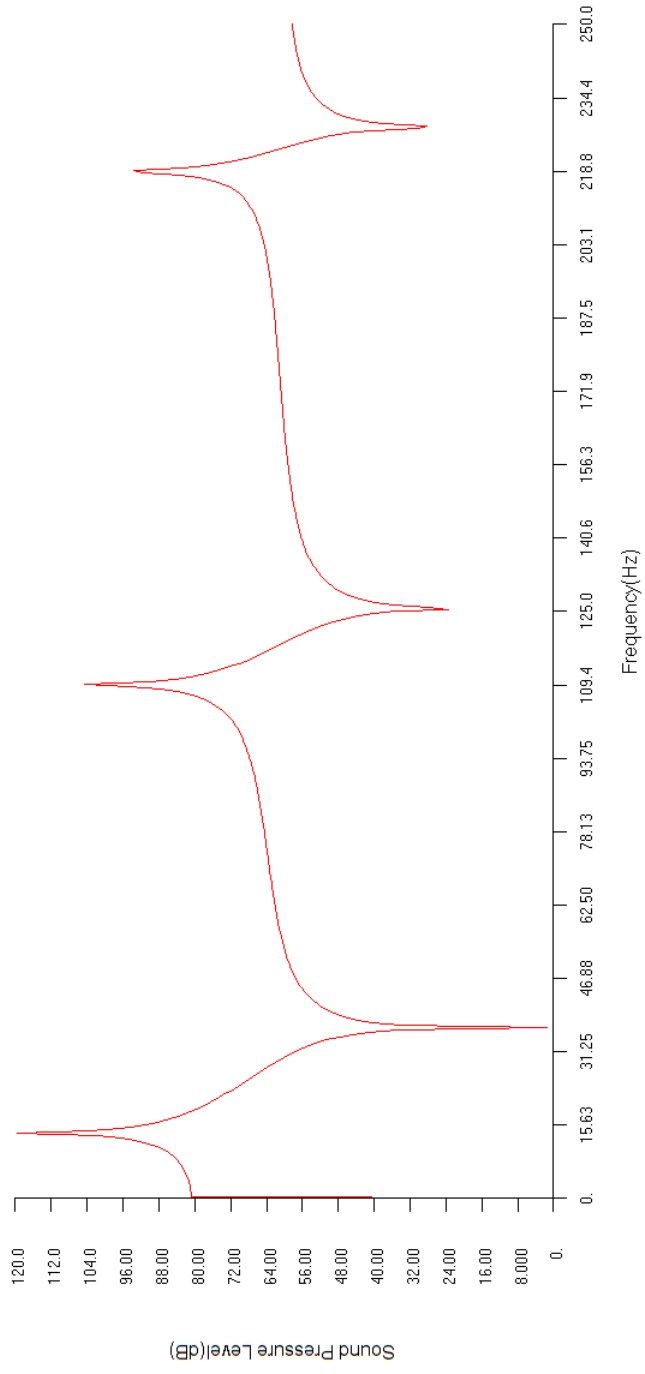

Figure 4.30: Mic AFT (dB) Vs Frequency (Hz) (Aluminum Tube with Dome End Caps, Fixed-Free Condition)

LEGEND
 FWD: Sound Pressure Level (dB)

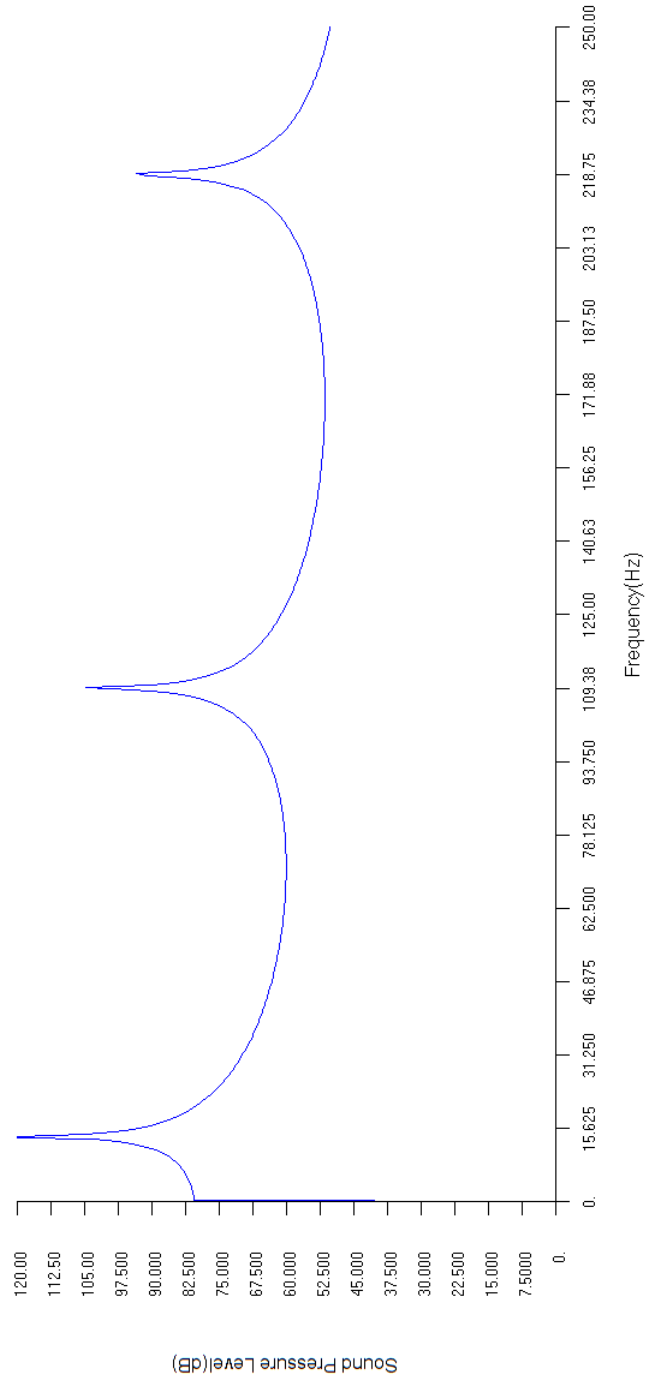

Figure 4.31: Mic FWD (dB) Vs Frequency (Hz) (Aluminum Tube with Dome End Caps, Fixed-Free Condition)

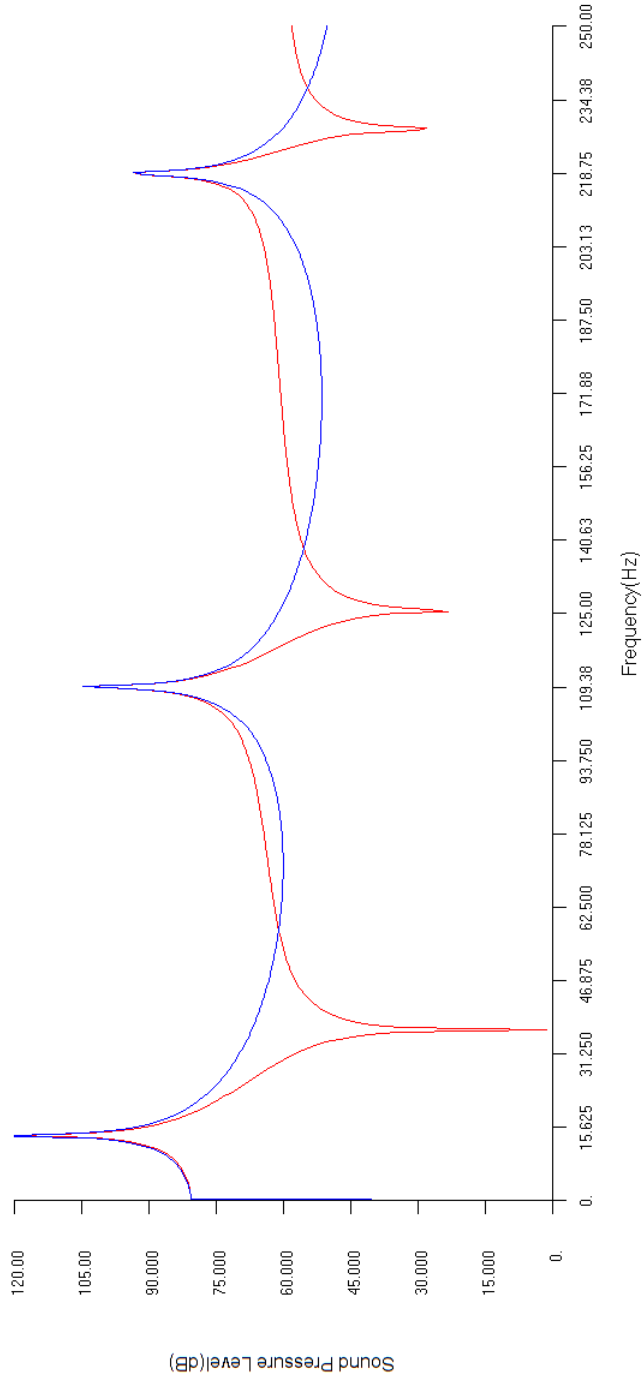

Figure 4.32: Sound Pressure Level (dB) Vs Frequency (Hz) (Aluminum Tube with Dome End Caps, Fixed-Free Condition)

LEGEND
 — AFT: Sound Pressure(Pa)

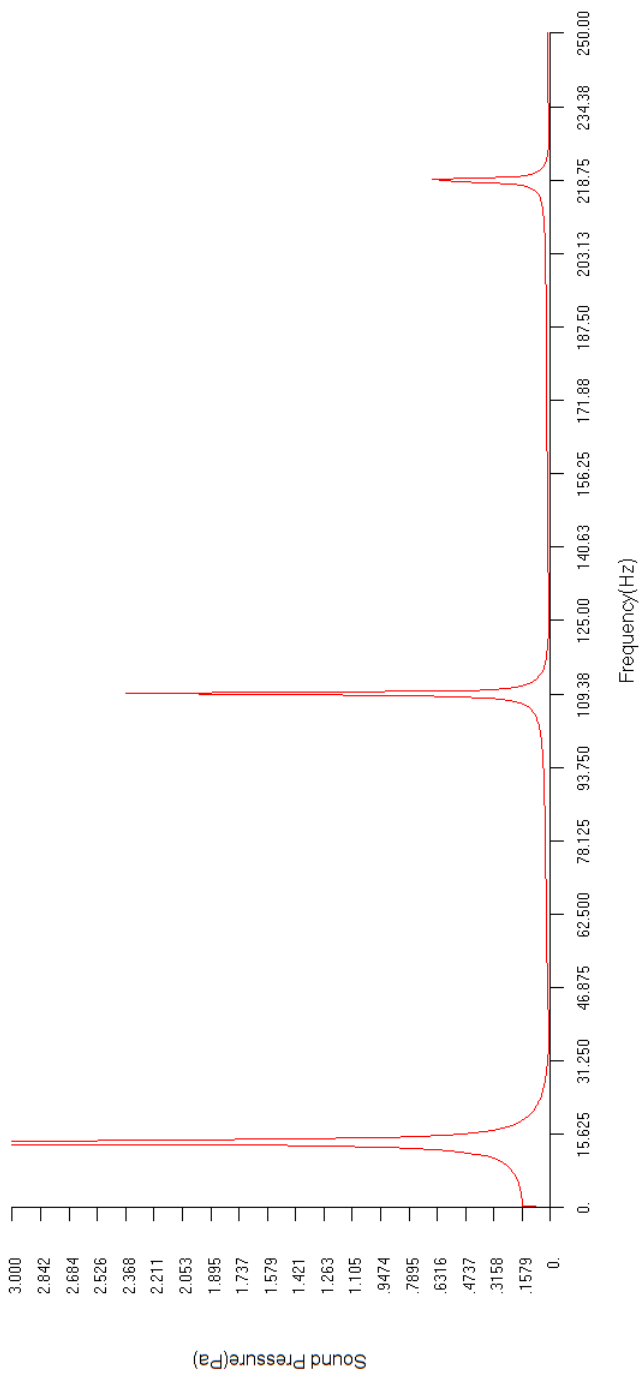

Figure 4.33: Mic AFT (Pa) Vs Frequency (Hz) (Aluminum Tube with Dome End Caps, Fixed-Free Condition)

LEGEND
 — FWD: Sound Pressure(Pa)

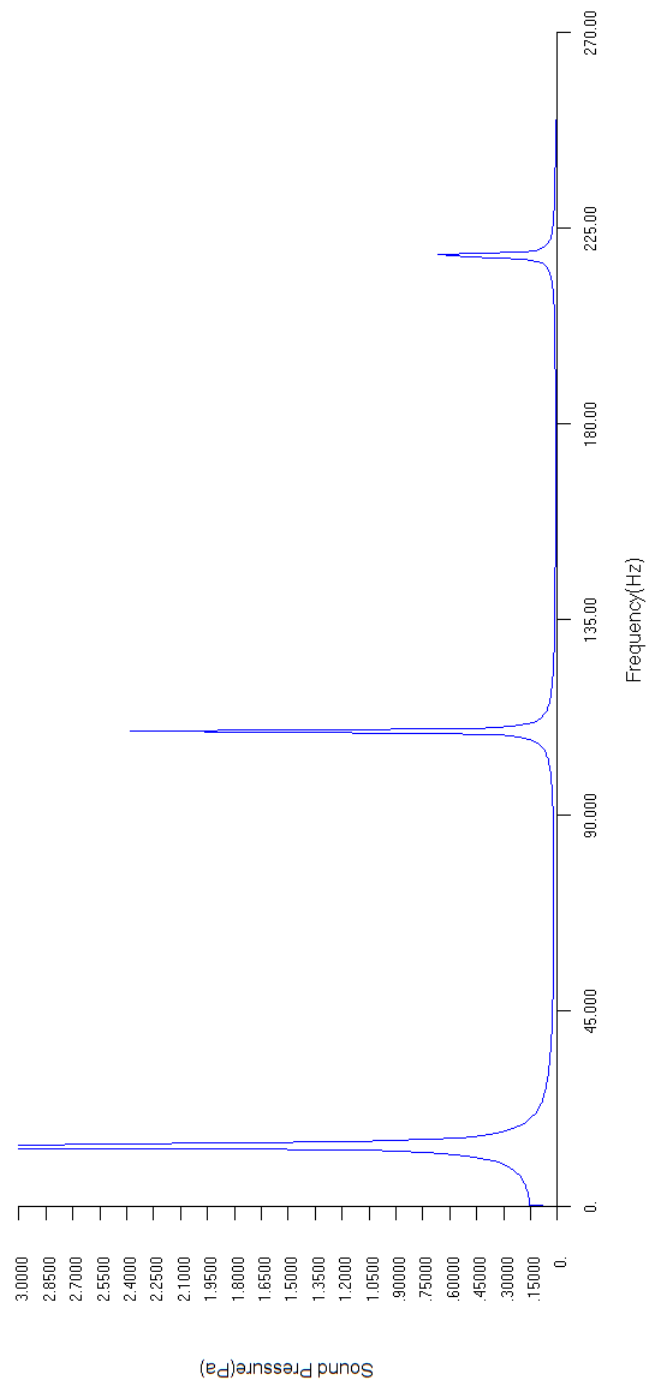

Figure 4.34: Mic FWD (Pa) Vs Frequency (Hz) (Aluminum Tube with Dome End Caps, Fixed-Free Condition)

LEGEND
 FWD: Sound Pressure(Pa)
 AFT: Sound Pressure(Pa)

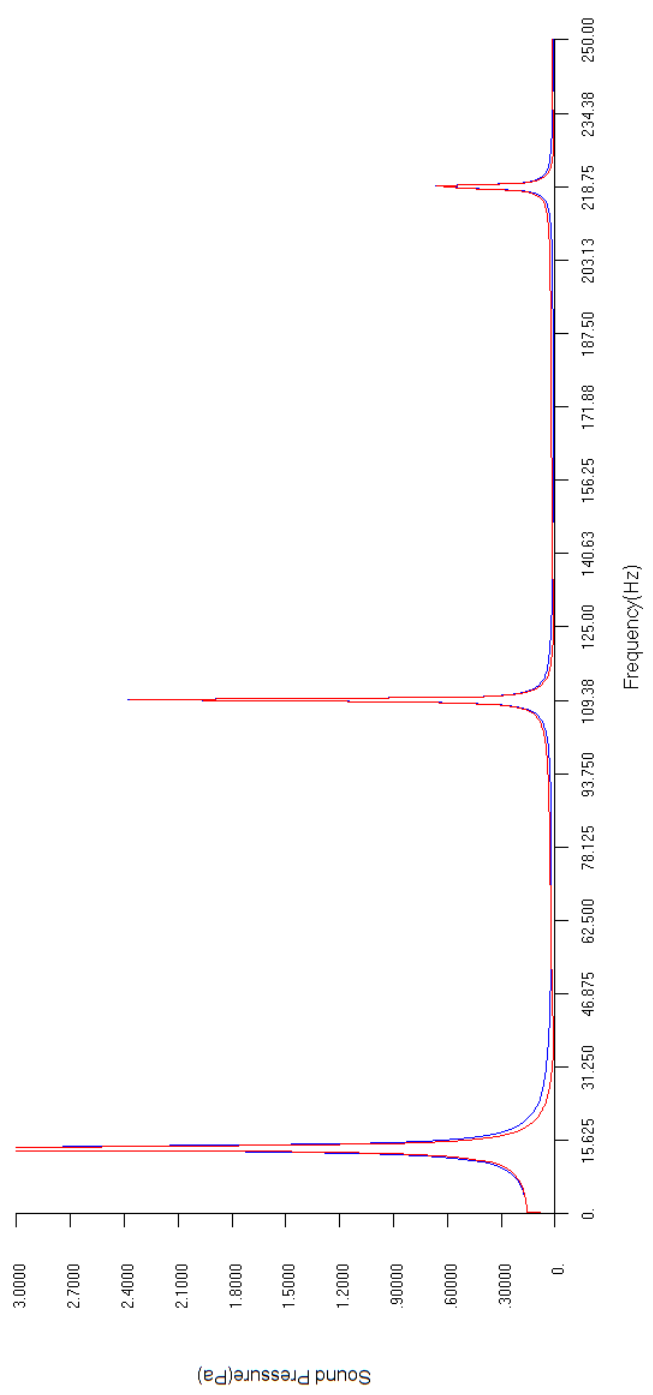

Figure 4.35: Sound Pressure (Pa) Vs Frequency (Hz) (Aluminum Tube with Dome Ends, Fixed-Free Condition)

Summary of Results

Table 4.5 presents the results of the numerical analysis for an aluminum tube with dome end caps (Fixed-Free Condition) using acoustic excitation.

Aluminum Tube with Dome End Caps using Acoustic Excitation		
	Numerical Results	
	Sound Pressure Level(dB)	Sound Pressure (Pa)
Fixed-Free Condition	104.52 dB at 109.5 Hz (Mic AFT)	2.368 Pa at 109.5 Hz (Mic AFT)
	105.00 dB at 109.5 Hz (Mic FWD)	2.375 Pa at 109.5 Hz (Mic FWD)

Table 4.5: Results of the Numerical Simulation for an Aluminum Tube with Dome End Caps (Fixed-Free Condition) using Acoustic Excitation

4.2.3 Fixed-Translation Boundary Condition

Figure 4.36 shows the mesh used for the numerical analysis of an aluminum tube with dome end caps (Fixed-Translation Condition)

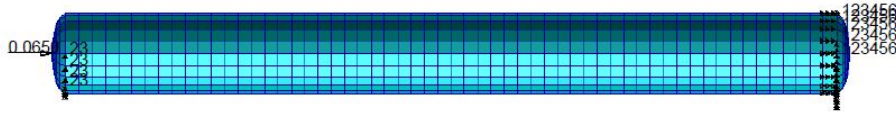

Figure 4.36: Numerical Analysis Mesh for an Aluminum Tube with Dome End Caps (Fixed-Translation Condition)

Results:

Figures 4.37 and 4.38 show the results of the numerical analysis for sound level (dB) versus frequency at the AFT and FWD microphones, respectively, in an aluminum tube with dome ends. At 109.5 Hz, the first peak is predicted to be at a sound level of 104.90 dB at Mic AFT and 104.430 dB at Mic FWD. Figure 4.39 is a composite of Figures 4.37 and 4.38 to facilitate the comparison of the sound levels expected at the AFT and FWD microphones.

Figures 4.40 and 4.41 show the results of the numerical analysis for sound pressure (Pa) versus frequency at the AFT and FWD microphones, respectively, in an aluminum tube with dome ends. At 109.5 Hz, the first peak sound pressure is predicted to be 2.360 Pa at Mic AFT and 2.373 Pa at Mic FWD.

Figure 4.42 is a composite of Figures 4.40 and 4.41 to compare the sound pressures expected at the AFT and FWD microphones.

LEGEND
 — AFT: Sound Pressure Level(dB)

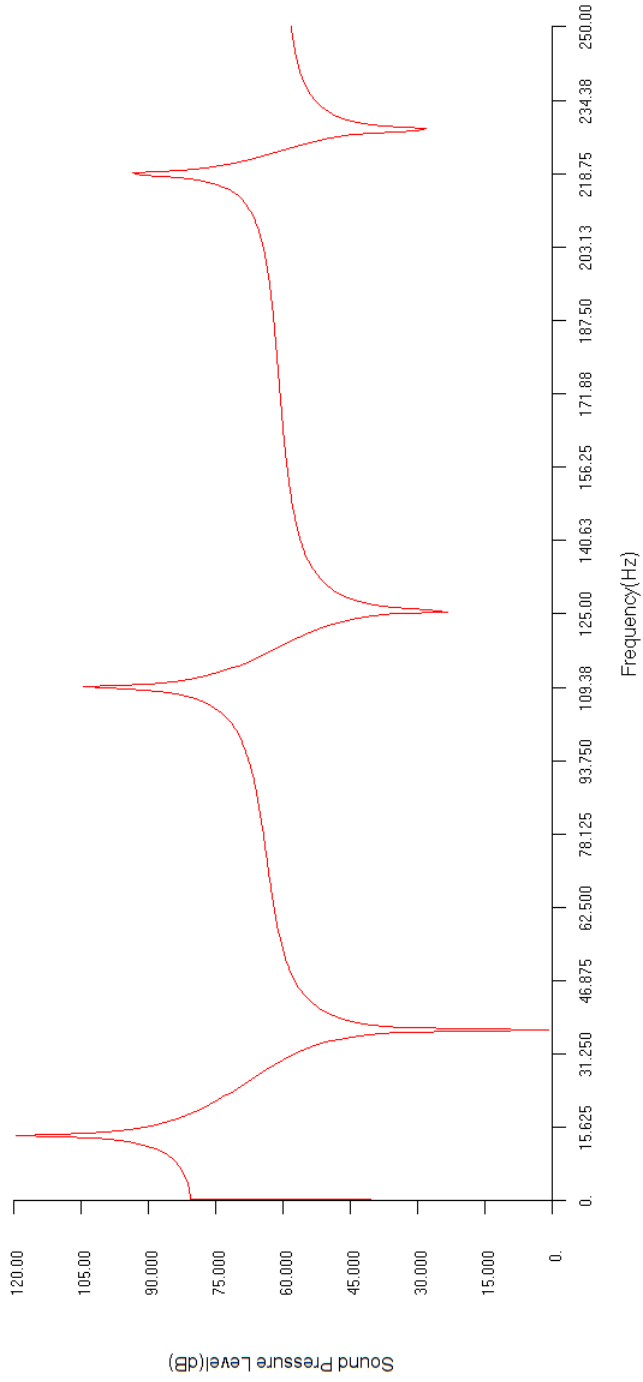

Figure 4.37: Mic AFT (dB) Vs Frequency (Hz) (Aluminum Tube with Dome End Caps, Fixed-Translation Condition)

LEGEND
 FWD: Sound Pressure Level(dB)

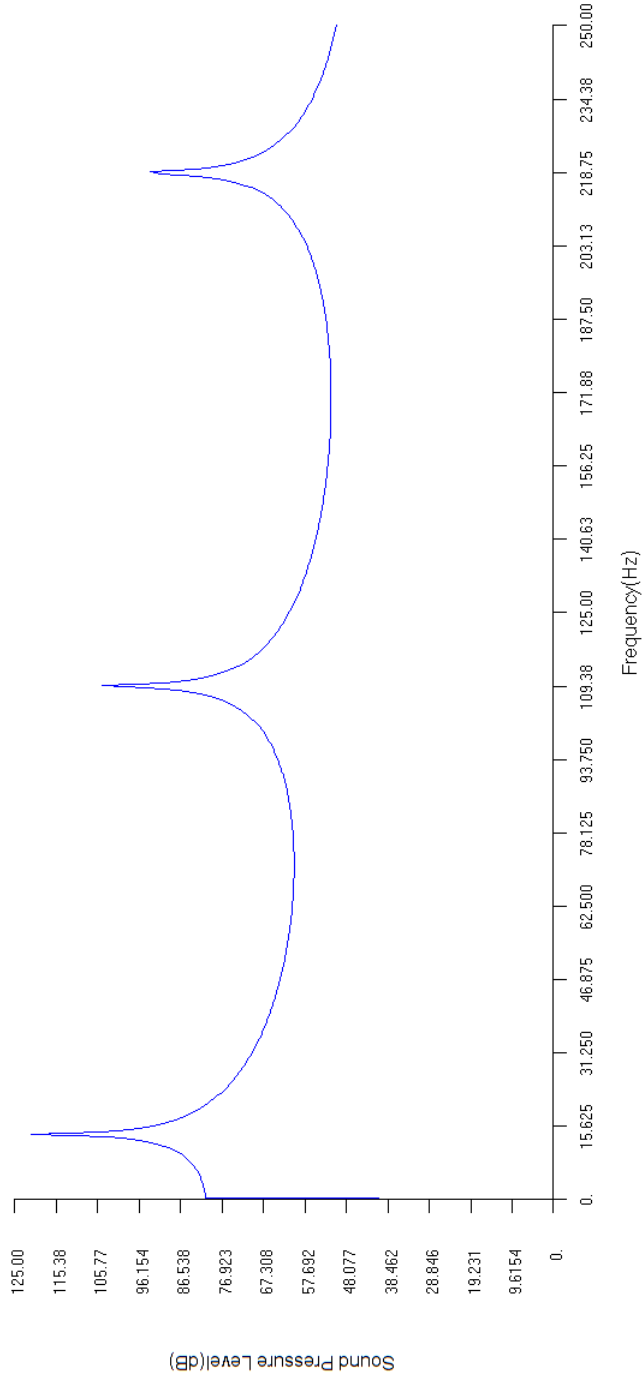

Figure 4.38: Mic FWD (dB) Vs Frequency (Hz) (Aluminum Tube with Dome End Caps, Fixed-Translation Condition)

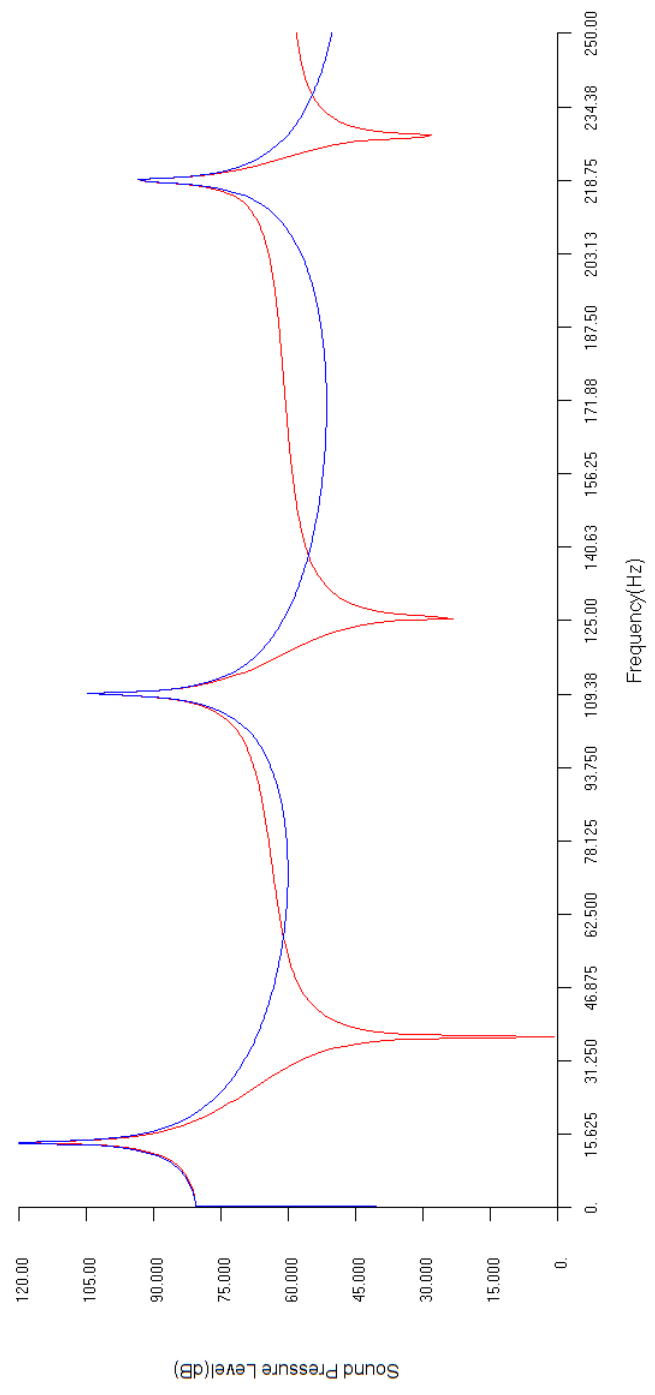

Figure 4.39: Sound Pressure Level (dB) Vs Frequency (Hz) (Aluminum Tube with Dome End Caps, Fixed-Translation Condition)

LEGEND
 — AFT: Sound Pressure(Pa)

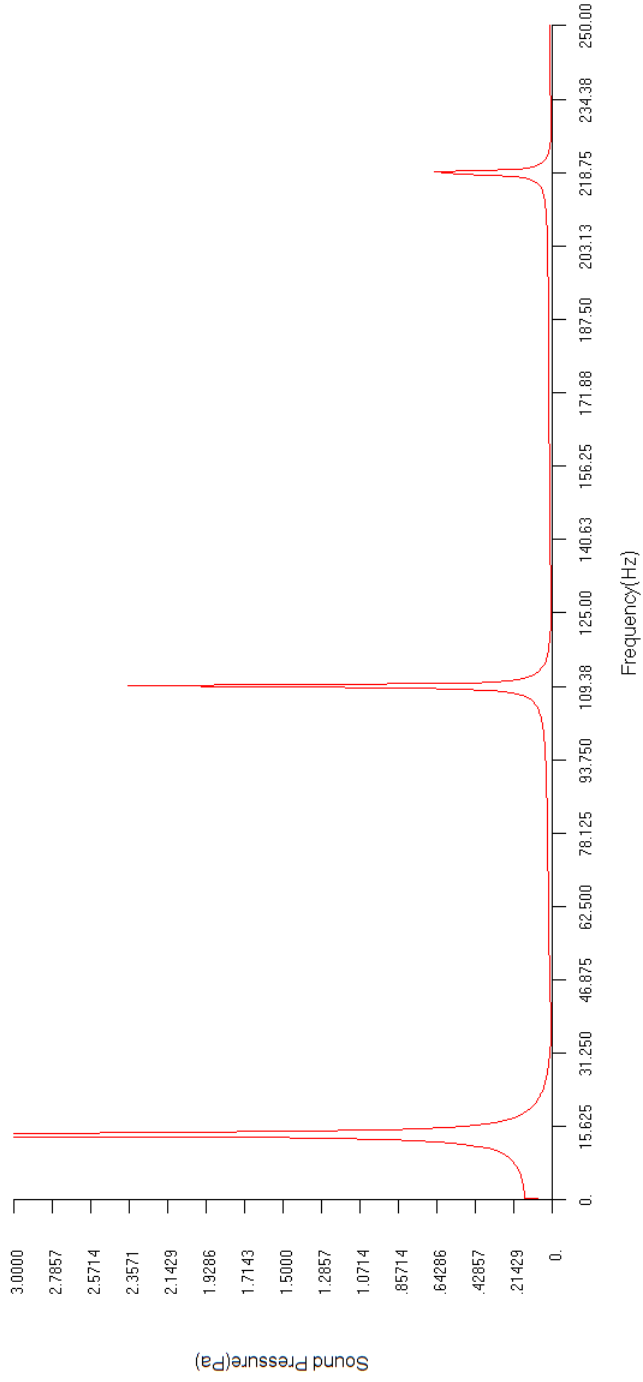

Figure 4.40: Mic AFT (Pa) Vs Frequency (Hz) (Aluminum Tube with Dome End Caps, Fixed-Translation Condition)

LEGEND
— FWD: Sound Pressure(Pa)

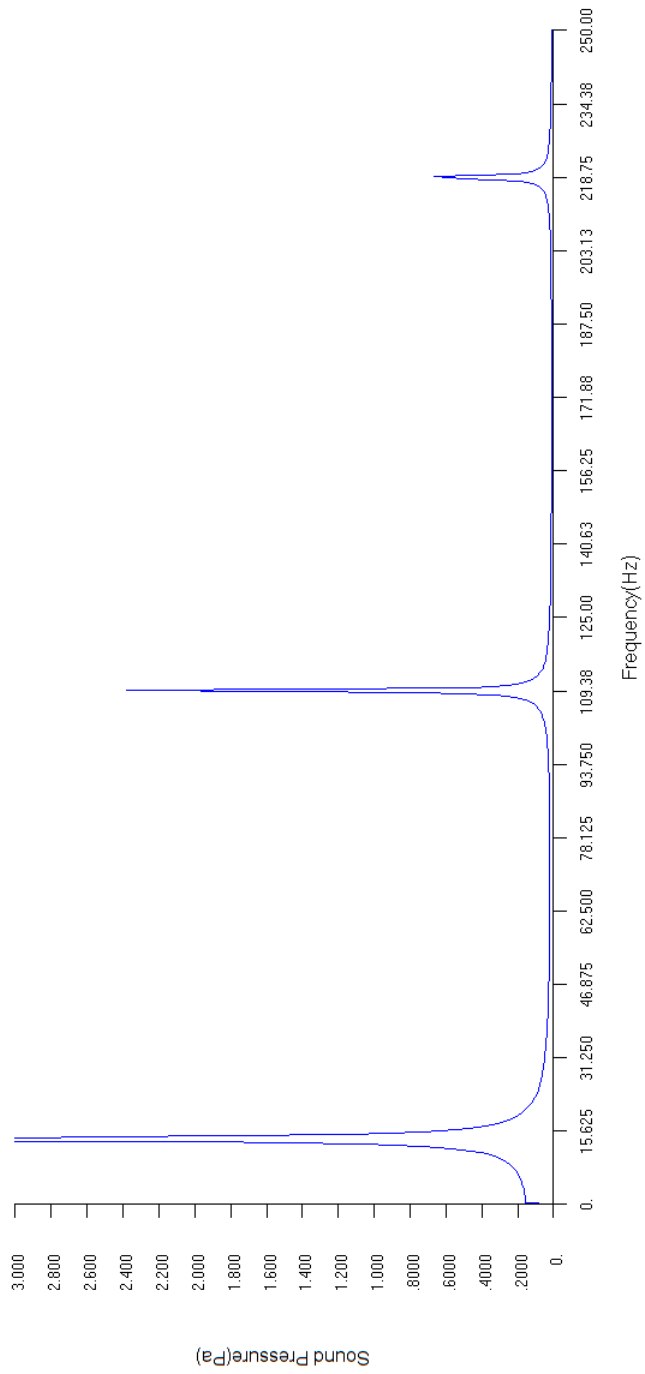

Figure 4.41: Mic FWD (Pa) Vs Frequency (Hz) (Aluminum Tube with Dome End Caps, Fixed-Translation Condition)

LEGEND
 - AFT: Sound Pressure (Pa)
 - FWD: Sound Pressure(Pa)

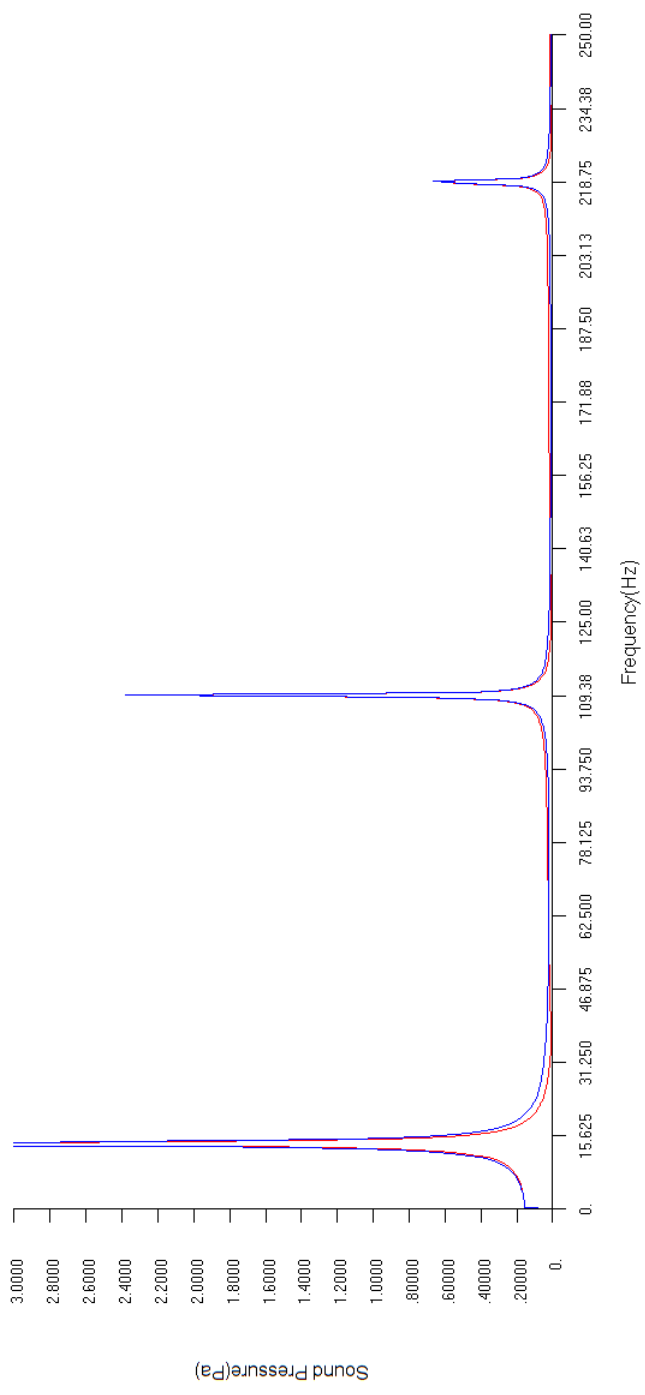

Figure 4.42: Sound Pressure (Pa) Vs Frequency (Hz) (Aluminum Tube with Dome End Caps, Fixed-Translation Condition)

Summary of Results

Table 4.6 shows the results of the numerical simulation for an aluminum tube with dome end caps (Fixed-Translation Condition) using acoustic excitation.

Aluminum Tube with Dome End Caps using Acoustic Excitation		
	Numerical Results	
	Sound Pressure Level(dB)	Sound Pressure (Pa)
Fixed-Translation Condition	104.43 dB at 109.5 Hz (Mic AFT)	2.360 Pa at 109.5 Hz (Mic AFT)
	104.90 dB at 109.5 Hz (Mic FWD)	2.373 Pa at 109.5 Hz (Mic FWD)

Table 4.6: Results of the Numerical Simulation for an Aluminum Tube with Dome End Caps (Fixed-Translation Condition) using Acoustic Excitation

Chapter 5

Conclusion

This chapter summarizes the work performed for this research project, reporting the analysis of the dynamic characteristics and acoustic properties of the aluminum tube with different end configurations (Flat and Dome End Caps) and boundary conditions (Free-Free, Fixed-Free and Fixed-Translation). The following tables show details of the dynamic characteristics and acoustic properties of the Aluminum tube .

Table 5.1 and 5.2 compare the experimental and simulation results for the dynamic characteristics and acoustic properties of an aluminum tube with flat end caps and dome end caps, respectively, while Table 5.3 and Table 5.4 focus on the experimental and simulated results, respectively.

Dynamic Response of Aluminum Cylindrical Tube with Flat End Caps using Acoustic Excitation				
	Experimental Method		Numerical Method	
	Sound Pressure Level(dB)	Sound Pressure(Pa)	Sound Pressure Level(dB)	Sound Pressure(Pa)
Free-Free Condition	97.230 dB at 95.00 Hz (Mic AFT)	1.454 Pa at 95.00 Hz (Mic AFT)	96.67dB at 97.22 Hz (Mic AFT)	0.897 Pa at 97.22 Hz (Mic AFT)
	99.288 dB at 95.00 Hz (Mic FWD)	1.843 Pa at 91.5 Hz (Mic FWD)	96.59 dB at 97.22 Hz (Mic FWD)	0.895 Pa at 97.22 Hz (Mic FWD)
Fixed-Free Condition	97.160 dB at 95.00 Hz (Mic AFT)	1.442 Pa at 95.00 Hz (Mic AFT)	98.46 dB at 97.22 Hz (Mic AFT)	1.138 Pa at 97.22 Hz (Mic AFT)
	99.180 dB at 91.50 Hz (Mic FWD)	1.821 Pa at 91.50 Hz (Mic FWD)	98.42 dB at 97.22 Hz (Mic FWD)	1.136 Pa at 97.22 Hz (Mic FWD)
Fixed –Translation Condition	97.138 dB at 95.00 Hz (Mic AFT)	1.439 Pa at 95.00 Hz (Mic AFT)	98.30 dB at 97.22 Hz (Mic AFT)	1.131 Pa at 97.22 Hz (Mic AFT)
	99.174 dB at 91.50 Hz (Mic FWD)	1.819 Pa at 91.50 Hz (Mic FWD)	98.25 dB at 97.22 Hz (Mic FWD)	1.128 Pa at 97.22 Hz (Mic FWD)

Table 5.1: Dynamic Response of Aluminum Cylindrical Tube with Flat End Caps using Acoustic Excitation

Dynamic Response of Aluminum Cylindrical Tube with Dome End Caps using Acoustic Excitation				
	Experimental Method		Numerical Method	
	Sound Pressure Level(dB)	Sound Pressure (Pa)	Sound Pressure Level(dB)	Sound Pressure(Pa)
Free-Free Condition	105.132 dB at 112.5 Hz (Mic AFT)	3.611 Pa at 112.5 Hz (Mic AFT)	104.00 dB at 109.5 Hz (Mic AFT)	2.142 Pa at 109.5 Hz (Mic AFT)
	105.687 dB at 112.5 Hz (Mic FWD)	3.849 Pa at 112.5 Hz (Mic FWD)	104.00 dB at 109.5 Hz (Mic FWD)	2.142 Pa at 109.5 Hz (Mic FWD)
Fixed-Free Condition	105.160 dB at 112.5 Hz (Mic AFT)	3.623 Pa at 112.5 Hz (Mic AFT)	104.52 dB at 109.5 Hz (Mic AFT)	2.368 Pa at 109.5 Hz (Mic AFT)
	105.712 dB at 112.5 Hz (Mic FWD)	3.860 Pa at 112.5 Hz (Mic FWD)	105.00 dB at 109.5 Hz (Mic FWD)	2.375 Pa at 109.5 Hz (Mic FWD)
Fixed –Translation Condition	105.144 dB at 112.5 Hz (Mic AFT)	3.616 Pa at 112.5 Hz (Mic AFT)	104.43 dB at 109.5 Hz (Mic AFT)	2.360 Pa at 109.5 Hz (Mic AFT)
	105.697 dB at 112.5 Hz (Mic FWD)	3.854 Pa at 112.5 Hz (Mic FWD)	104.90 dB at 109.5 Hz (Mic FWD)	2.373 Pa at 109.5 Hz (Mic FWD)

Table 5.2: Dynamic Response of Aluminum Cylindrical Tube with Dome End Caps using Acoustic Excitation

Dynamic Response of Aluminum Cylindrical Tube using Acoustic Excitation				
	Experimental Method (Dome End Caps)		Experimental Method (Flat End Caps)	
	Sound Pressure Level(dB)	Sound Pressure(Pa)	Sound Pressure Level(dB)	Sound Pressure(Pa)
Free-Free Condition	105.132 dB at 112.5 Hz (Mic AFT)	3.611 Pa at 112.5 Hz (Mic AFT)	97.230 dB at 95.00 Hz (Mic AFT)	1.454 Pa at 95.00 Hz (Mic AFT)
	105.687 dB at 112.5 Hz (Mic FWD)	3.849 Pa at 112.5 Hz (Mic FWD)	99.288 dB at 91.50 Hz (Mic FWD)	1.843 Pa at 91.50 Hz (Mic FWD)
Fixed-Free Condition	105.160 dB at 112.5 Hz (Mic AFT)	3.623 Pa at 112.5 Hz (Mic AFT)	97.160 dB at 95.00 Hz (Mic AFT)	1.442 Pa at 95.00 Hz (Mic AFT)
	105.712 dB at 112.5 Hz (Mic FWD)	3.860 Pa at 112.5 Hz (Mic FWD)	99.180 dB at 91.50 Hz (Mic FWD)	1.821 Pa at 91.50 Hz (Mic FWD)
Fixed –Translation Condition	105.144 dB at 112.5 Hz (Mic AFT)	3.616 Pa at 112.5 Hz (Mic AFT)	97.138 dB at 95.00 Hz (Mic AFT)	1.439 Pa at 95 Hz (Mic AFT)
	105.697 dB at 112.5 Hz (Mic FWD)	3.854 Pa at 112.5 Hz (Mic FWD)	99.174 dB at 91.50 Hz (Mic FWD)	1.819 Pa at 91.50 Hz (Mic FWD)

Table 5.3: Dynamic Response of Aluminum Cylindrical Tube using Acoustic Excitation(Experimental Method)

Dynamic Response of Aluminum Cylindrical Tube using Acoustic Excitation				
	Numerical Method (Dome End Caps)		Numerical Method(Flat End Caps)	
	Sound Pressure Level(dB)	Sound Pressure(Pa)	Sound Pressure Level(dB)	Sound Pressure(Pa)
Free-Free Condition	104.00 dB at 109.5 Hz (Mic AFT)	2.142 Pa at 109.5 Hz (Mic AFT)	96.67dB at 97.22 Hz (Mic AFT)	0.897 Pa at 97.22 Hz (Mic AFT)
	104.00 dB at 109.5 Hz (Mic FWD)	2.142 Pa at 109.5 Hz (Mic FWD)	96.59 dB at 97.22 Hz (Mic FWD)	0.895 Pa at 97.22 Hz (Mic FWD)
Fixed-Free Condition	104.52 dB at 109.5 Hz (Mic AFT)	2.368 Pa at 109.5 Hz (Mic AFT)	98.46 dB at 97.22 Hz (Mic AFT)	1.138 Pa at 97.22 Hz (Mic AFT)
	105.00 dB at 109.5 Hz (Mic AFT)	2.375 Pa at 109.5 Hz (Mic FWD)	98.42 dB at 97.22 Hz (Mic FWD)	1.136 Pa at 97.22 Hz (Mic FWD)
Fixed –Translation Condition	104.43 dB at 109.5 Hz (Mic AFT)	2.360 Pa at 109.5 Hz (Mic AFT)	98.30 dB at 97.22 Hz (Mic AFT)	1.131 Pa at 97.22 Hz (Mic AFT)
	104.90 dB at 109.5 Hz (Mic FWD)	2.373 Pa at 109.5 Hz (Mic FWD)	98.25 dB at 97.22 Hz (Mic FWD)	1.128 Pa at 97.22 Hz (Mic FWD)

Table 5.4: Dynamic Response of Aluminum Cylindrical Tube using Acoustic Excitation(Numerical Analysis Method)

The data presented in Table 5.1 show that the results of the experimental and numerical methods for sound pressure levels (dB) and sound pressure (Pa) at the natural frequency are consistent for an aluminum tube with flat end caps for the three boundary conditions tested (Free-Free, Fixed-Free and Fixed- Translation). The data in Table 5.2 confirm that this is also the case for an aluminum tube with dome end caps, as once again the experimental and numerical results for sound pressure levels (dB) and sound pressure (Pa) at the natural frequency are consistent for all three boundary conditions (Free-Free, Fixed-Free and Fixed-Translation).

The information presented in Table 5.3 demonstrate that the experimentally measured sound pressure levels (dB) and sound pressure (Pa) at the natural frequency were higher in the aluminum tube with dome end caps than in the aluminum tube with flat end caps. The results of the numerical simulation shown in Table 5.4 agree, with the results of the numerical simulations for sound pressure levels (dB) and sound pressure (Pa) at the natural

frequency also being higher in the aluminum tube with dome end caps than in the aluminum tube with flat end caps.

Given that the experimental and numerical results for sound pressure levels (dB) and sound pressure (Pa) at the natural frequency of the aluminum tube with both flat and dome end caps compared very well for all three boundary conditions (Free-Free, Fixed-Free, Fixed-Translation), it is reasonable to conclude that the experimental results validated the numerical model constructed for this study.

Bibliography

- [1] Anooshiravan Farshidianfar, Mohammad H Farshidianfar, Malcolm J Crocker, and Wesley O Smith. Vibration analysis of long cylindrical shells using acoustical excitation. *Journal of Sound and Vibration*, 330(14):3381–3399, 2011.
- [2] WW Liessa. Vibration of shells, nasa sp-288. *National Aeronautics and Space Administration*, 1973.
- [3] John Nichols. Theoretical and experimental comparison of pressure in a standing wave tube with attenuation.
- [4] Yiren Simon Wang. Transmission of sound through a cylindrical shell and a light aircraft fuselage. 1982.
- [5] Wesley Oliver Smith III. *An Empirical and Computational Investigation into the Acoustical Environment at the Launch of a Space Vehicle*. PhD thesis, Auburn University, 2013.
- [6] Donald E Hall. *Basic acoustics*. Wiley, 1987.
- [7] NM Price, M Liu, R Eatock Taylor, and AJ Keane. Vibrations of cylindrical pipes and open shells. *Journal of sound and vibration*, 218(3):361–387, 1998.
- [8] Anoshirvan Farshidianfar and Pouria Oliazadeh. Free vibration analysis of circular cylindrical shells: comparison of different shell theories. *International Journal of Mechanics and Applications*, 2, 2012.
- [9] Werner Soedel. *Vibrations of shells and plates*. CRC Press, 2004.