

A Systematic Approach to the Classification of Physical Connections in Product Design

by

Xue Dong

A thesis submitted to the Graduate Faculty of
Auburn University
in partial fulfillment of the
requirements for the Degree of
Master of Industrial Design

Auburn, Alabama

May 7, 2016

Keywords: physical connection, aesthetic, classification

Copyright 2016 by Xue Dong

Approved by

Randall Bartlett, Chair, Professor of Industrial Design
Shea Tillman, Associate Professor of Industrial Design
Shu-wen Tzeng, Associate Professor of Industrial Design

ABSTRACT

Physical connection plays an important part in product design. This thesis focuses on discussing physical connection in product design. Physical connection is the junction area of two or multiple parts. This thesis aims to develop a systematic classification system for the physical connections in product design, which might help product designers gain a better understanding and knowledge about physical connections and the use of them in product design, thus improving the aesthetic consciousness of the physical connection of product design.

There are several methods utilized in this study. First, the researcher will collect several types of physical connections in different product categories. The author would like to inspire the designers thinking about the aesthetic perspective of physical connections by exposing and analyzing the current physical connections. In addition, the researcher will explore the factors that have impact on physical connection selection. In order to create a relatively reasonable classification method of physical connection, the researcher will conduct a qualitative research among product designers.

A web gallery will be created by applying the newly created classification system in its design, this website would be a open platform for the user to find the required information by using the filter. By tracking the customer's searching behavior, the researcher could collect enough data to refine this classification system of physical connections in order to develop a better web gallery for designers to use.

ACKNOWLEDGEMENTS

I would like to express my great thankfulness for the support of my committee members. To my chair Randall, Bartlett, who guided me through every step of my research period and resources, thanks a lot for generosity for the past three years. To my committee members Shu-wen Tzeng and Shea Tillman for your helpful input and feedback on this thesis, and also thanks for your academic help for past three years.

To all students and designers who participated in the research part, thanks a lot for your dedication and patience to finish the survey. Without your participation, I could not finish the thesis. Your input and encouragement helped the author a lot throughout the research.

To the Auburn Industrial Design faculties Chris Arnold, who advised me to use system thinking in the project, Dylan Piper-Kaiser and Rusty Lay for your input and helpful of the research.

To my friend Xinwei Yan, who provided suggestions for my website design.

Personal thanks go out to my family, especially my Mom and Dad. I love you all. Thanks to for all the encouragement, now and before.

SOFTWARE USED

Style manual or journal used:

APA Style, Sixth Edition

Computer software used:

Microsoft Office: Mac 2011

Adobe Photoshop CS6

Adobe Illustrator CC

Just In Mind 7.0

TABLE OF CONTENTS

Abstract	ii
Acknowledgments	iii
Software Used	iv
List of Figures	viii
List of Tables	xii
1 Introduction	1
1.1 Problem Statement	1
1.2 Need for Study	2
1.3 Objective of Study	4
1.4 Definitions of the Terms	4
1.5 Assumptions	6
1.6 Scope and Limits	7
1.7 Procedure of Study	8
1.8 Anticipated Outcomes	8
2 Literature Review	10
2.1 Development and Revolution of Physical Connection Design	10
2.2 Case Study of Physical Connections in Wood Product	12
2.2.1 Wood-to-Wood Connection	13

2.2.2 Wood-to-Metal Connection	19
2.2.3 Wood-to-Plastic Connection	24
2.2.4 Wood-to-Soft Material Connection	28
2.2.5 Wood-to-GlassConnection	29
2.2.6 Wood-to-Multiple Material Connection	31
2.3 Considerations of Physical Connection Design	33
2.3.1 Form Follows Function	34
2.3.2 Simplicity.	36
2.3.3 Safety.	37
2.3.4 Balancing between the material, function and aesthetic.	41
3 Research	47
3.1 Research Methodology	47
3.1.1 DSM Model.	47
3.1.2 Qualitative research	48
3.1.3 Radar Chart.	48
3.1.4 Graphical Chart.	48
3.1.5 Classification.	49
3.2 Research Procedure	49
3.3 Research Conclusion	54
3.3.1 General Findings	54

3.3.2 Form Transition & Material Transition.....	60
3.3.3 Connection Type	63
3.3.4 Structure.....	64
4 “CSMA” Classification System Approaches.....	69
4.1 Connection Type Classification	69
4.2 Structure Classification	72
4.3 Appearance Classification	74
5 Design Application of The “CSMA” Classification System	78
5.1 Function	78
5.2 Sitemap & Wireframe	79
5.3 Website User Interface	83
6 Summary and Future Extension	86
7 Reference	90

LIST OF FIGURES

Figure 1 Chinese mortise and tenon joint	1
Figure 2 Chair from Nicola Zocca's 'Shrink' Collection.....	11
Figure 3 Connection of Floating Console Table.....	14
Figure 4 Joinery of Assemblage Table	15
Figure 5 Finger Joint Chair.....	15
Figure 6 Dovetail Connection of “Sleek” Table	16
Figure 7 Chair of 'Splinter' Collection.....	17
Figure 8 Table of “Androgyne”	18
Figure 9 “+” Table	18
Figure 10 Table Lamp of “Notus”	20
Figure 11 Chair of “MultipliCITI” Flat-pack Outdoor Public Furniture.....	21
Figure 12 Outdoor Lamp created by BYAM.....	21
Figure 13 Knock-down Corner Table	22
Figure 14 Parts of Knock-down Corner Table.....	22
Figure 15 OSS Furniture Collection.....	23
Figure 16 Pilo Table	24
Figure 17 3D Printed Furniture Connector.....	25
Figure 18 3D Printed Connector”Keystones”	26
Figure 19 the “Stool Production Unit”	27

Figure 20 Buckle of Jet Armchair for Habitat	29
Figure 21 Børge Mogensen Hunting Chair	29
Figure 22 Table of Horizon	30
Figure 23 Evans Coffee Table	30
Figure 24 Vintage Coffee Table	31
Figure 25 Handle of “ Carry On” Portable Seating Solution	32
Figure 26 “Carry On” Portable Seating Solution	32
Figure 27 Peninsula Chair	33
Figure 28 Strollers for Stokke	35
Figure 29 Helsinki Loudspeaker	36
Figure 30 Corner of “Nora” Table	38
Figure 31 Library Stool	39
Figure 32 Lunar Bar Chair	39
Figure 33 “Paint or Die But Love Me” Table	40
Figure 34 Triangle Connection of Plywood Table	41
Figure 35 Lindberg Titanium Case	43
Figure 36 Detail of “Wood X Plastic” Shelf	45
Figure 37 “+” Table	45
Figure 38 3D Printed Connector “Keystones”	45
Figure 40 Classified Notes on Black Board	50

Figure 41 Survey Poster Layout	52
Figure 42 Email Version Survey Result	53
Figure 43 Gubi Bestlite BL3 M Floor Lamp	56
Figure 44 Survey Result of “Simple Table” Connection.....	57
Figure 45 Connection of Floating Console Table.....	58
Figure 46 Tube Desk Lamp	58
Figure 47 Plastic Connection of “ADD System”	59
Figure 48 Bottle Humidifier	59
Figure 49 Connection of “63 Grad” Bench	60
Figure 50 Detail of Joy Table	61
Figure 51 Welding Connection of MilaneseIllustration	62
Figure 52 Duffel Stool	62
Figure 53 Wood Handle of “Handle Me”	63
Figure 54 Connection of Mamet Lamp	64
Figure 55 Traverson Table	64
Figure 56 Connection of Butty Shelve	65
Figure 57 Connection of Madeline Table	65
Figure 58 Armada Armchair	66
Figure 59 Trapeze Large LED Table Lamp	67

Figure 60 Detail of VASI Bench.....	68
Figure 61 “ CSMA” System	69
Figure 62 Simple Table” Connection	74
Figure 63 Hinge of Lenovo yoga 3 pro Laptop	77
Figure 64 Connection of IGLOO Floor Lamp	77
Figure 65 Initial Sitemap of the Physical Connection Gallery Website	79
Figure 66 Concept 1 of Physical Connection Gallery Website	79
Figure 67 Concept 2 of Physical Connection Gallery Website	80
Figure 68 Filter of Gallery Type.....	80
Figure 69 Filter Material Selection.....	81
Figure 70 Revised Sitemap of the Physical Connection Gallery Website.....	81
Figure 71 No Result Conditions	82
Figure 72 Revised Wireframe of f Physical Connection Gallery Website	82
Figure 73 Homepage Layout	83
Figure 74 Gallery Page Layout.....	85
Figure 75 Connection of Strollers for Stokke.....	88
Figure 76 Graphical Model of Stroller Connection Design Consideration	88
Figure 77 Connection of “63 Grad” Bench	89
Figure 77 Graphical Model of “63 Grad” Bench Connection Design Consideration	89

LIST OF TABLES

Table 1 Basic Classification of Physical Connection	50
Table 2 Demographic of the Survey participants	51
Table 3 Labels provided in Survey	52
Table 4 Labels used in Survey	54
Table 5 Matrix of the Physical Connection Classified Labels.....	56
Table 6 Survey Result of the “Simple Table” Connection	57
Table 7 Survey Result of the “Armada Armchair” Connection	66
Table 8 Survey Result of “Trapeze LED Table Light.....	67
Table 9 Connection Type Classified of Physical Connection.....	72
Table 10 Structure Classified of Physical Connection	74
Table 11 Appearance Classified of Physical Connection	76
Table 12 The “CSMA” Classification of Hinge of lenovo yoga 3 pro laptop.....	77
Table 13 The “CSMA” Classification of Connection of IGLOO Floor Lamp.....	77
Table 14 Terminology used for different aspects	87

1. INTRODUCTION

1.1 Problem Statement

As normal people, even designers, we notice that screws are in the table, but we unconsciously accept that they ought to be there and ought to be that shape. As can be seen from this example, most time the functional aspect is the dominant aspect in the physical connections, the aesthetic aspect of this areas is usually ignored, even if there exists smart connections such as the Chinese mortise and tenon joint structure (Figure 1) in the furniture design, which has already developed a mature methodology for a long period. It is still hard to expand this particular example to other types of product categories, to inspire designers to create original and unique physical connections.

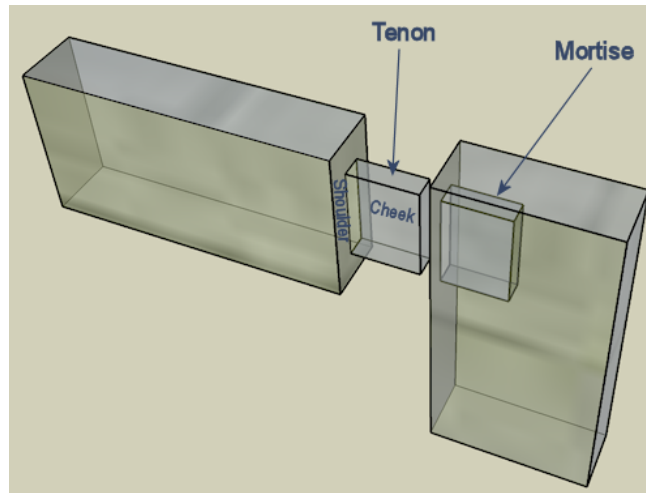

Fig 1 Chinese mortise and tenon joint (“Mortise”, n.d.)

Currently, there is not a collection of available physical connection information. There are some reasonable ways to explore and develop a more systematic index. Firstly, the more collecting and analyzing of current cases, the deeper understanding of how to consider the aesthetic aspect of the physical connection in the product design becomes possible. Plus, knowing how

people classify and describe the physical connections in the product and how they think about different aspects in their minds will immediately highlights the aspects of the physical connections that need to be improved.

However, these solutions may be hindered by several dilemmas. Firstly, this research is subjective, because it is difficult to obtain a common aesthetic recognition from the people. People's knowledge of physical connections is influenced by a series of complex factors. Moreover, everyone has a different criteria of preference in different contexts, and in the same context, one person might have a different level of enthusiasm from another. Many variables and personal factors will cause much difficulty for researchers. So it is difficult to say that the index developed in this study can be used in every situation or context.

1.2 Need for Study

Physical connections play a crucial role in product design. If there are no physical connections in a product, there will be no function, causing chaos in the product. Although physical connection is increasingly being recognized by designers and producers as an important part of product design, and there has been some research discussing about physical connections in mechanical perspective. However, from the product design perspective, there are relatively little investigations into physical connection.

There are several reasons for so little investigation of this field. Firstly, the word "aesthetic" is too abstract to describe, which means it is difficult to measure. Aesthetic attributes are those that relate to the senses: sight, touch sound, smell and taste (Hekkert,2006). That is the main reason why aesthetic are difficult to measure. Secondly, apart from aesthetics, there are several fac-

tors, such as ergonomic, material and function, that add more complexity of the system for the physical connection. At last, conflicts between function and aesthetic is a common and extensive issue in the design field, In addition, how to apply the advanced technology and keep the balance between the function and aesthetics is becoming an essential issue for designers and producers.

Considering personal preferences, technology limits and functions of the mechanical connections, there exist issues between the function and aesthetic. So, understanding how to balance the function and aesthetic aspects, and find optimized design tools would be meaningful for designers.

This subject will benefit several aspects of the product development field. From the customers' point of view, this study will help customers gain a better understanding and knowledge about physical connections and the use of them in product design, thus improving the aesthetic consciousness of the physical connection of product design. The improvement of the aesthetic consciousness will force the market product diversity which will increase competition for the producers. Also, the manufacturer will benefit from the study. A marketing variable that is gaining recognition as being a significant factor in the competitive marketplace. From their point of view, they would prefer to expand to as many customers as they could. They will gain more in cooperating creative technology and aesthetic in more optimized way, thus obtaining more profits from the market.

This project will investigate the original principles of physical connection in the product design field and analyze typical current cases, thus creating approaches or indexes for producers, designers or engineers to deepen their understanding and consciousness of aesthetic aspects and develop a systematic toolbox to help designers and manufacturers to consider more about aes-

thetic aspects when creating and manufacturing new products, especially in regards to physical connections.

1.3 Objective of Study

- To inspire designers by comparing and analyzing different types of existing physical connections
- To organize and evaluate typical physical connection cases to inspire designers
- To study the considerations of design of physical connections in products; identify aspects of those connections and their relationships that have impacts on physical connection selection
- To investigate how people think and describe physical connections in product design
- To figure out the obstacles of creating physical connections
- Develop a reasonable classification approach to help designers and engineers understand the physical connections more deeply and clearly
- To build an open platform to encourage more discussions regarding the physical connection field

1.4 Definition of the Terms

Buckle: a fastening for two loose ends that is attached to one and holds the other by a catch (“Buckle”, n.d.)

Chamfer: The surface produced by bevel long off a square edge or corner equally on both sides (“Chamfer”, n.d.)

“CSMA” Classification: “C” means “connection type”, “S” means “structure”, “M” means “material”, “A” means “appearance”.

Form Transition: “The transition of one form into the other” (Punekar, n.d.)

Hinge: a usually metal piece that attaches a door, gate, or cover to something and allows it to open and close (“Hinge”,n.d.)

Hook: “a curved or bent tool for catching, holding, or pulling something” (“Hook”, n.d.)

Joggle Joint: “a joint between two pieces of building material by means of a projection on one piece that fits into a notch in the other” (“ Joggle Joint”, n.d.)

MDF: MDF is “Medium Density Fiberboard”, is a type of hardboard material, which is made from wood fibers glued under heat and pressure (“MDF”n.d.)

Mortise-And-Tenon joints: “There are two components of this kind of joint: a mortise which is essentially a hole cut into one board, and a tenon which is a tongue that is shaped onto the end of another board which will fit into the mortise” (“Mortise”, 2015)

Physical connection: junction area of two or more parts connected in a product

Prototype: “a prototype is an initial model of an object built to test a design” (Blackwell & Manar, 2015)

Secondary research: “(also known as desk research) involves the summary, collation and/or synthesis of existing research rather than primary research, where data is collected from, for example, research subjects or experiments” (Sunny & Matthew, 2003).

Sitemap: A site map is a visual or textually organized model of a website's content that allows the users to navigate through the site to find the information they are looking for, just as a traditional geographical map helps people find places they are looking for in the real world (Rouse, 2005)

Sling Chair: “a chair formed of a metal or wooden frame to which a piece of canvas, leather, or other flexible material is loosely fitted” (“Sling Chair”,n.d.).

Slip connection: slip connection is a type of mechanical connection that allowing extension and compression in a linear structure. It is always used in drawer design. The movement trail could be linear or nonlinear.(“Slip”, n.d.)

1.5 Assumptions

There exist a number of assumptions that may affect outcomes and applicability of the current study. The first assumption is that connection type, material, appearance and structure all contribute to the final decisions of the physical connection design. In some examples, the type of connection or the structure are not clear displayed in a physical connection, but the researcher will assume that they still exist.

The second assumption is among factors that have an impact on selection of the physical connection design, connection type and material aspects are more objective, thus designers have less space for free play. That is to say the type of connection and material are the given conditions before considering the connection design. However, compared with type of connection, material selection still has more possibilities, so designers could choose the different colors and finishings to improve visual effects. So connection type is the first and most important factor at the beginning of designing physical connections.

The third assumption is that designers do not need to think about the manufacturing and cost. Manufacturing and cost aspects are important for product design, but the actual situation is when designers creating the concepts at early design stages, they do not need to consider about manufacturing factor, most of their work is balancing the material, form and function.

The last assumption is that “people have always been attracted by new, unfamiliar, and

original things, partly to overcome boredom and saturation effects” (Martindale,1990).This phenomenon also works for physical connection design. That is to say, if physical connections are created with unique shapes and fresh material, which is largely differentiated from what people commonly see, this physical connection will inspire more positive visual effect for the designers.

1.6 Scope and Limits

This research focuses on the topic - physical connections in product design and their classification. In this case, the author will first discuss about physical connections and then discuss classification of these physical connections.

The scope of this research is primarily qualitative research. Due to the limited time available, the researcher collected many connections, covering product categories such as furniture, lighting, kitchen appliances and so on. It is impossible for the researcher to collect all types of connections. The author discuss and analyze the wood product as a representative in the literature review chapter. If more resources (such as big data system) and time might be available in the future, the researcher would like to conduct a series of quantitative research studies via the internet.

There are several limitations of this thesis. This thesis is more about user-centered research. It would have been ideal to communicate with a relatively larger group of participants in a wide range of locations. However, considering the time and budget, it is difficult to survey enough samples in such a short time. Therefore, the research conducted in this thesis only includes designers and design students in the Southeast area of the US. Fewer than 20 designers participated in the research.

Another limitation is that there are too many various factors which will have an impact on the selection of the physical connection design. Some factors are not tangible and not easy to explore, so it is difficult to analyze factors very clearly and how they interact with each other. And this limitation is from people's cognitive factors and emotional factors. Participants' education level, personal experiences, preferences, and cultural background will greatly influence their understanding of the physical connections, which may cause some influence of the results.

1.7 Procedure of Study

At the beginning, secondary research will be the dominant method to collect physical connections from different product categories. Comparing and analyzing of wood product will help people better understand the physical connections design. Then the author will discuss about the considerations for physical connection design, which might inspire product designers.

In addition, qualitative research will be conducted to observe how people classify and describe the provided physical connections. This research is divided into three main parts: collecting data, organizing & analyzing the cases and finally summarizing & communicating.

After the qualitative research, the "CSMA" classification ("C" means "connection type", "S" means "structure", "M" means "material", "A" means "appearance") system will be created, based on the explored aspects that impact physical connection design.

Finally, a website will be created to display the research result and involve more people to apply and optimize the classification system.

1.8 Anticipated Outcomes

The first finding of this study is the considerations that needed to be paid attention for designing physical connections. The second finding is a relatively reasonable classification system by analyzing the typical cases and observing how people classify and describe the connection. This thesis will identify some ways to demonstrate the classification system in a hope to improve designers' sense of aesthetic.

This thesis could also potentially have some long-term influence as a whole. First of all, if more budget and time is available in the near future, the survey could be developed into a quantitative research study, which will help designers extend and optimize the "CSMA" classification system. In addition, this study may improve the peoples's aesthetic consciousness of the product design, especially the physical connection field. With a deeper and more comprehensive understanding of physical connections, designers will feel comfortable with physical connections in his or her design.

2 LITERATURE REVIEW

2.1 Development and Revolution of Physical Connection Design

Before the 20th century, an object's value was often” determined by the way its constituent elements combined together”, especially in the furniture industry (Keane-Cowell ,n.d.). Due to the limitation of material and technology at that time, most of the furniture was made by wood. Most wood joints are permanently reinforced with glues, screws or nails. Some screws and nails destroys the whole product aesthetics. Keane-Cowell (n.d.) pointed out in his article that “the more integrated and streamlined the joint, the greater the perceived level of workmanship and joint was all about seamless unity”. Even in today’s world, designers prefer to consider hiding some joinery structures at first. As McQuarrie (2015) mentioned in her article “15 Creative Furniture Joinery Pieces,”designers focus on hiding furniture joinery techniques. It is supposed that the mainstream design group preferred furniture appear to be as seamless as possible.

However, opposite opinions merged in early 20th century. Over time, more advanced machinery has improved manufacturing and construction. New materials are generated seemingly nearly at every moment. In the chair design field, Keane-Cowell (n.d.) pointed out for seating elements, the area where joining the various parts was no longer preferred to be concealed and denial, some connecting area became the visually independent. This phenomenon is not limited to chair design, it could directly switch to the all kinds of furniture. Designers are not satisfied with the traditional aesthetic contributions of the joinery, they would like to convey their personal technical statement or material exploration. This is exemplified in the “Shrink” series (see Figure 3) by Nicola Zocca, which uses heat-shrink plastic joints to hold its constituent wooden components together..



*Fig 2 Chair from Nicola Zocca's 'Shrink' Collection
(Keane-Cowell, n.d.)*

These rigid joints are formed by wrapping the plastic around them, heating it, and then letting it cool (Keane-Cowell, n.d.). The manufacturing method is simple because the only energy resource is the hot air. Zocca is not the only designer design according to that opinion. According to McQuarrie (2015), connectors could become focal point of a design. Revealed connections are becoming design highlights of today's world.

Designers have been figuring out innovative ways of building furniture, some of them consider as much of technical statement as they do an aesthetic statement (Keane-Cowell, n.d.). Physical connection area is a good place for designers to show their statement to the society.

In conclusion, no matter whether the joints are revealed or concealed, making physical connections more of an integral part of the design and less of an afterthought is becoming mainstream for both customers and designers. In order to achieve that, knowing the existing common physical connections is the first step to optimizing the use of mechanical joints such as screws and nails, after which one can improve the aesthetic considerations of the physical connection

design.

2.2. Case Study of Physical Connections in Wood Product

The three types of materials still taking dominant position in manufacturing industry are wood, metal and plastic, and most of the product categories are based on these three families of materials, used alone, or in combination. Whether as the product body or as physical connection, wood is the most commonly applied materials, as a traditional material and a long-term application. The researcher will discuss wood products as a representative material in this chapter, the method will also be extended to analogous materials.

As one of the world's easy-to-manufacture and relatively cheap materials, wood are widely used in product design. As Hawks (1987) mentioned in her article, wood is one of the most commonly used materials to make chairs and benches because of its "rich appearance, durability, and ease of construction"

Aesthetic factors play different roles in different furniture categories. Compared with outdoor furniture, aesthetics are more important in interior furniture. Customers care more about aesthetic aspect of chairs rather than tables and stools. And for chairs, aesthetics are more difficult to consider because aesthetic factors need to be combined with ergonomic and functional factors. However, no matter how different the categories are and how important the aesthetics are in different categories, connection is important in furniture design in both appearance and durability. Hawks (1987) pointed out that wood chair quality is mostly determined by the kind of joining parts of the wood chair and sturdiness of the chair. Hawks's comments reflect the importance of the joining in wood chairs, but this conclusion cannot be restricted to wood chairs, but can be

extended to any types of wood furniture. Although this chapter focuses more on the aesthetic aspects, functional aspects still need to be discussed.

2.2.1 Wood-to-Wood Connections

As mentioned before, there are two basic options for designers to optimize the connections. One type is to optimize the existing and mature connection with more integrated and streamlined joint. A large amount of designers still prefer to convey their thinking through optimizing the traditional wood connection techniques. Another way is to apply the advanced technology and material knowledge to turn connectors into a focal point of a design. These two methods will be discussed separately.

Traditional wood physical connections would be discussed at first. There are several common joints that are typically applied in furniture design: edge, butt, rabbet, dado, miter, lap, mortise and tenon, dovetail, and finger. These joints are selected according to their different advantages and disadvantages. Some types of joints, such as lap, mortise and tenon, and doweled are usually used for joining chair arms and rungs, or joining the rails and legs. Other types of joints such as edge, miter and dado are typically seen to combine the boards such as book shelves and drawers. Among these joint types, lap, mortise and tenon, and finger might have more aesthetic application potentials than other types. All above joints could be called joggle joint. And these types of joints are a relatively integrated system in the wood industry, so here the author will not discuss them any more. One area of concern is, that these field-special words are hard to remember for designers. So the following paragraph, the author would like to discuss the terms in a less specialized way, using furniture design examples.

Dado is kind of a physical connection which usually seen in drawer design. “Dado-is a groove cut across the grain” (Hawks 1987). This kind of joint can combine the boards strongly enough. Most common applications of furniture categories are steps, book cases, and drawers. Below is a popular drawer design available on [etsy.com](https://www.etsy.com) (see Figure3) “ We use solid quarter sawn white oak for the drawers and exterior of our handmade floating console table. The drawer fronts are ebonized with natural earth pigments, and use a drawer lock joint for visual interest and strength” (McKenzie, 2015). McKenzie used the dado joint and emphasized the area by applying different contrasting colors for visual interest and strength. Good handcraft increased the



Fig 3 Connection of Floating Console Table (McKenzie, 2015)

aesthetic appearance and visual quality. So for this physical connection, the two dominant aspects are function and aesthetic. The material selection is based on the the function and aesthetic considerations.

One of the most popular joints in the furniture field is the mortise and tenon joint. It can be seen both chairs and tables. For example, it can be used to join the rails and legs of the table and

it can be seen to join the chair frame and legs to the chair. The mortise and tenon consists of a socket and projection made of two different pieces of wood, and the projection fits into the socket making the joint. (Hawks,1987) It is not difficult to conclude that this type of joint is strongly enough. In addition, the connecting area is decorated with pattern of the shape of socket and projection. Stephane Lebrun's Assemblage Table (see Figure 4) is evident in the precise mortise and tenon joinery. The aesthetic aspect is emphasized by the joinery.



Fig 4 Joinery of Assemblage Table (Budds, 2010)

The finger joints are fit for box constructions both the natural wood and the MDF. Below is a chair called "Finger-joint-chair" (see Figure 5). The connection between back rest and arm rest is made of finger joints, which is obviously seen at the



Fig 5 Finger Joint Chair (Lee,n.d.)

first glance. This chair is created by Korean designer Lee, Lee (n.d.) claimed that the idea came from the research about the material nature of the wood. This design could be seen the material and technology exploration. He optimized the traditional joint techniques to show his research. Lee (n.d.) also talked that the highlight of finger joint chair is the wood connect. Finger joint can create some special patterns, which adds more details to the product. The visual quality could also be improved by high-quality handcraft. From the Lee's work, it is easy to conclude that finger joint also has variety visual potentials for aesthetic considerations of connection design.

When traditional wood connection is combined with smooth form transition, it could bring a pleasantly surprise for the furniture. The dovetail joint could be described as that type of joint. It is strong because of the way tails and pins are shaped. "Sleek Table" (see Figure 6) is a nice evidence of above opinion. The impressing area of the table is the the elegant and sinuous

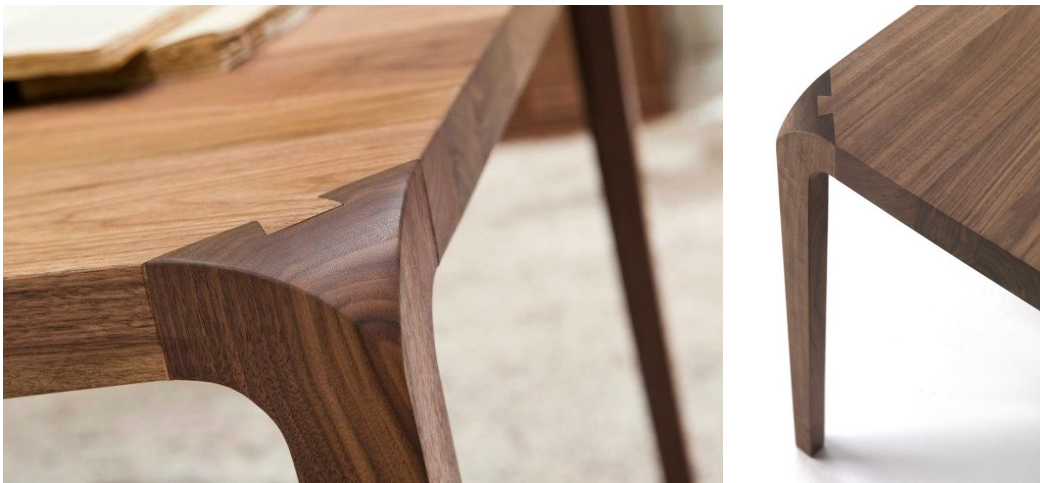

Fig 6 Dovetail Connection of "Sleek" Table ("Sleek", n.d.)

shape. The sinuous shape was emphasized through the connection between the legs and tale top. The legs are in solid wood, reinforced with an internal metal structure and joined to the top by means of a special system of dove-tail joints (Rashid, 2013). The dovetail joint is strong because

of the way tails and pins are shaped. The advantage of dovetail is not only the strong strength but also the visual variations. It also need good craft to gain more impressive appearance.

Different from above conventional designers, a large number of designers still prefer to convey their thinking through new exploration of material and technology. The first example is a furniture collection designed by Nendo (see Figure 7). Regarding Nendo's (2012) thinking when cre-



Fig 7 Chair of 'Splinter' Collection (Nendo, 2012)

ating this type of split connection. he says, “We splintered each piece of wood as though peeling it away.” (Nendo, 2012) From what he said, we could find that he was thinking about the way it structured. According to Nendo (2012), thickness changes smoothly in order to satisfy for different functional requirement and strength. Form changes could serve different functions.

Smooth form transition is not only a good example, some exaggerated shapes could also be a good technique for wood to wood connection design. Androgyne (see Figure 9) is a table made with pine and steel which consists of a simple system: table leg and top. The feature of this table

is the joinery. Two elements, a male and a female plug, make up the table . The male and female part demonstrate they are looking for their own missing part in the opposite part (Colleuille,



Fig 8 Table of “Androgyne” (Colleuille, 2012)

2012). This joinery communicates an action to the people. The groove and the steel is hidden underneath the table, to keep the structure looking clean and help people concentrate more on the joinery itself. While the table legs turn into crutches, serving to hold the table top, they are at the same time supported by the table top itself.

The “+” table’s name comes from the way it assembled (see Figure 9). The focal point of this de-



Fig 9 “+” Table (Williamson , 2013)

sign is the cross-shaped joints. The combination intersect at 90 degrees. The design takes a single sheet of laminated plywood and turns it into a sustainably produced table with cross-shaped joints (Williamson, 2013). By manufactured with CNC milling machine, the “+” table’s parts are cut with precision out of one sheet, making for minimal waste. The cross-shaped joints strongly expressed the designers sustainable statement.

In conclusion, both optimizing the traditional joints and exploring new techniques are important for wood-to-wood connection developing. Making physical connections merged more with original design and less of an extra part is still a challenge for designers.

2.2.2 Wood-to-Metal Connections

Wood-to-metal connections are not typically used for wood products. Compared with wood-to-wood connection, manufacturing is relatively time-consuming and a little bit difficult. However, the fact is many parts such as steel tubing, cast legs and other small parts are often seen in all kinds of product categories, such as office chairs and kitchen appliances, so discussion is still required for metal-to-wood connection. It is easy to understand that metal could provide durability and sturdy, more so than other materials. But this is not the only reason why metal to wood connection is used widely in wood products. Another reason is from the aesthetic’s perspective. Shapes of metal could be diversity, such as tube, sheet or injected in organic forms, which provide variety of forms for designers. Likewise, multiple types of finishing effect would increase the visual interest from color and texture. Thus, if high durability and visual quality is needed, metal is an ideal choice for designers and manufacturers.

Notus is a table lamp design consists of wood and powder coated metal. (see Figure 10) The coated metal penetrates in two pieces of wood. Notus demonstrates a simple graphic pattern from the side view. The designer's idea is to use "single parts follow a simple geometric principle" (Putzier, 2012). It is supposed that the joining method is very directly because the



Fig 10 Table lamp "Notus" (Putzier, 2012)

metal part is directly piercing into the wood part. Obviously contrast of that area is noticed because there is no shape or color that could work be as a transition.

However, not all the metal to wood connections are as described above. A set of public furniture design (see Figure 11) is a suitable example to explain the form transition in connecting different pieces. The frame is made by cast aluminum, there are no screws or there extra parts. The sculptural shapes of frames and volumes outline a distinctive profile that is identifiable at a distance. (Béhar, 2014) From the long distance, the profile conveys a a simplicity design philosophy. Clear boundary and bright color also help the area identifiable noticed by people. While, if it is noticed of the form at closer distance, refined joinery and transitions from flat to convex sur-

faces become visible (Béhar, 2014). The form transition provides a visual consistency of the connection area,



Fig 11 Chair of “MultipliCITI” flat-pack outdoor public furniture (Béhar, 2014)

Another example of outdoor furniture is an outdoor lamp (see Figure12). The branch metal is fixed with the wood body via traditional mechanical screws. This connection appears smooth at the first glance. Although the screw is revealed, the relatively small proportion and good crafts



Fig 12 Outdoor Lamp created by BYAM (BYAM, 2013)

manship makes the screws look in harmony with the product environment. As outdoor furniture, sturdiness and durability are important. Apart from the visual effect, the screws also demonstrate that the lamp head is fixed to the body.

Metal-to-wood connections are not only seen in outdoor furniture, it is always seen in interior furniture and decorative objects as well. In interior furniture category, easy-to-disassemble furniture is becoming more and more popular among customers. In today's world, living and housing cost are increasing quickly. Easy-to-disassemble structure could help the customers save more space. The realization of the easy-to-disassemble structure of furniture is relied on the physical connection to a great extent. So physical connection design is a key element in that type of the furniture.

The below corner table is a knock-down coffee table (see Figure 13 & 14) consisting of two main components: a plywood frame and a steel top. The unique feature of this table is the material combination. The four legs with laminated plywood and laquered black make the people easy to generate illusion that legs are made by metal. The legs come together to provide a support for the bent steel top finished in a matte black powder coat. The character of this table is enhanced by the flowing form of the support structure and the focal point it creates from the nega-



Fig 13 Knock-down Corner Table (Irvin,2011)



Fig 14 Parts of Knock-down Corner Table (Irvin,2011)

tive space present at the tables corners(Irvin, 2011). By playing and exploring the material and finish techniques, the designer created more visual interests for customers.

The OOS Collection (see Figure 15) is a set of furniture collection which consists of a ceiling lamp, coffee table and side table. The main feature of this design is the simplicity of the connections between the metal plate and the wood (Charinratana, 2011). The thinking of the connection demonstrate the designer’s excellent creativity of material and structure. There are no trails of the adhesive that connects the pieces, so the design follows the simplicity philosophy. The metal plate is held by the wood rods through a slit. There is no screw and nails because the slit allows the plate to be “locked” at a perpendicular angle to the ground (Charinratana, 2011). By using the slit, the wood was inserted into the metal plate and achieve the function in a simple way.



Fig 15 OOS Furniture Collection (Charinratana, 2011)

Pilo is a table (see Figure16) made with plywood and features cast aluminum connectors between the legs and table top. The idea was driven by the idea of creating light objects (Etherington, 2012).



Fig 16 Pilo Table (Etherington, 2012)

The simple profile of the connector also looks visually clean . It is supposed that the the designer has reduced the parts as less as possible.

Common features are concluded form the above typical connections. Firstly, it is obviously that metal-to-wood connections are made in a lot manufacturing steps, as simple as possible is a better choice for this type of connection. Secondly, if one would like to combine more visual diversity effects, metal is a good option to be considered. Lastly, as mentioned at the beginning, metal could provide more strength, if high durability is required, designer could consider to use metal.

2.2.3 Wood-to-Plastic Connections

As discussed at the beginning of this chapter, designers today are not satisfied with the traditional aesthetic contributions of the joinery. Instead, they would like to convey their personal technical statement or material exploration. A wood-to-plastic connection could be a strong type to demonstrate these preferences. The combination of wood and plastic could create a strong visual impact thanks to the material contrast. Material contrast is not hard to understand because

most of the wood surface is rough and has special wood texture, but the surface of the most plastic demonstrates a smooth, bright feeling. Another reason why designers prefer to use wood-to-plastic to convey their technical or material exploration is that advanced technology such as 3D print technology of plastic could realize modular furniture mode which could broad more design versatile for both designers and customers. People can build, destroy and rebuild again everything through special plastic connectors. Following these thoughts, several examples will be discussed in the following paragraphs.

Variable open-sourced 3D print joints (see Fig 17) were created by Hungarian designer Ollé Gellért to allow people to create their own functional furniture. He would like people to build their own furniture without tools, machines and mechanical components. Wooden boards combined with these 3D printed furniture connectors could allow people to make such things as

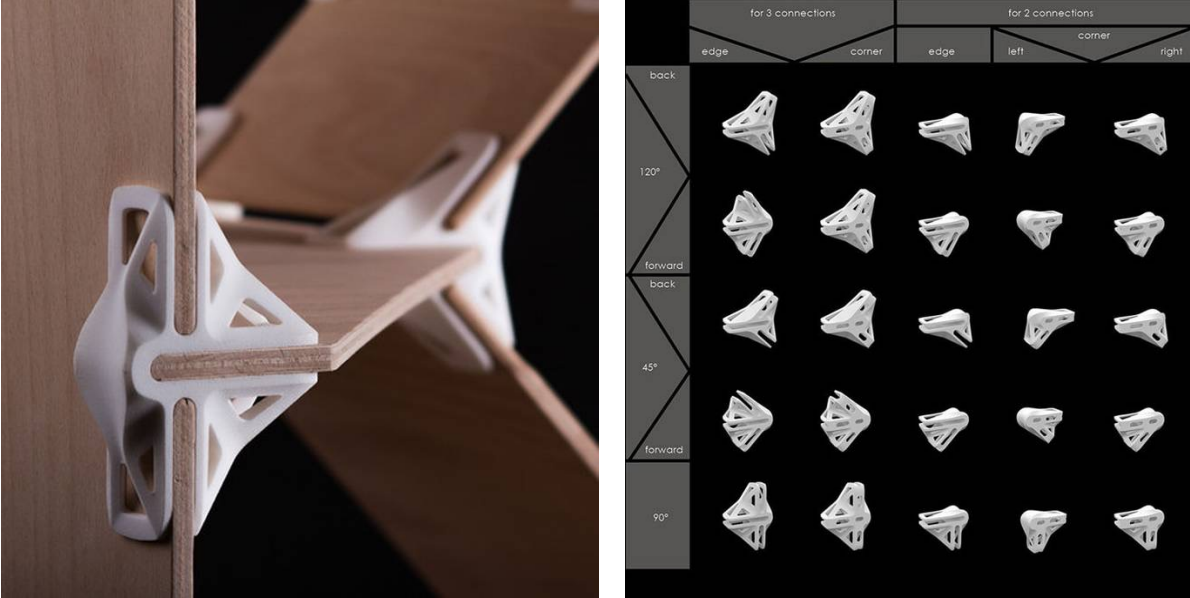

Fig 17 3D Printed Furniture Connector (Mok,2015)

shelves, tables or stools.He explains that focusing on the smaller components, allows anyone to

create larger structures (Mok, 2015). The whole joint system contains 90, 45 and 120 degrees elements which will satisfy most of the structural requirements of the furniture. What the customers need to spend is the standard wood sheet and connectors, they do not need to spend money on manufacture and transportation. So this idea could also save more money for the customer. We could imagine that people could not afford a 3D printer big enough to print out a full-sized table or chair. So the ability to print joints will benefit those customers who would like to build their own furniture and spend less money.

Ollé Gellért is not the only person who would like to apply 3D print technology to furniture connection design. One year ago, at Milan's Salone del Mobile in April, Dutch Studio Minale-Maeda recently showcased Keystones (see Figure 18), a collection of 3D printed connectors (Mok, 2014) The connector would help the producers to reduce the tools and fasteners. By achieving this, so it would be cheaper to design and furniture. The name “Keystone” convey the



Fig 18 3D Printed Connector “Keystones” (Prindle, 2014)

meaning that this connector can hold all the components together by locking all parts together.

No matter how large the furniture is, it could be easily disassembled by unlocking the parts and packing the pieces in a flat-pack.

Above two examples combine the sustainable concept with the open source possibilities of 3D printing the physical connection design.

Apart from these pioneer designers, many designers still use traditional manufacturing techniques to realize their design. A table called “ The Stool Production Unit” (see Figure 19) is a low tech plastic table created by Thomas Vailly. The unique feature of this is the smooth surface at the connection area. The designer explored the shape by using the traditional mold techniques, which he thought would be as simple as use 3D modeling software (Vailly, 2013). From what he



Fig 19 Stool Production Unit (Vailly, 2013)

thought, we could find that he use traditional technique to convey his statement. To achieve that kind of organic shape, Latex sheet is used as mold. The desired shape is then solidified with water base resin (Vailly, 2013). The selected material is also important to achieve the organic shape. When dried, the latex sheet is peeled off leaving a perfect smooth surface. When the desired shape is reached, the mold is then covered with a water base resin and solidify in a few hours. Every product comes with glossy or mat finish.

To sum up, as a relatively fast developing mass-production material, plastic is flexible both in shape and texture. Some people might argue that metal is also flexible in shape and texture, sometimes even greater than plastic. However, in majority situations, metal manufacturing is more time-consuming and it cost relatively more money for producers. If the requirement of strength is not so high, plastic could replace the metal to achieve similar functions and visual effects.

2.2.4 Wood-to-Soft Material Connection

Wood combined with soft materials connections are usually seen in our daily life. Compared with relatively hard materials such as metal and plastic, wood-to-soft material connections have more variations.

Wood-to-soft material connections are often seen in furniture design, especially in chairs. Most of the time the function of the connection makes the part knocked down. With the easy-to-bend feature, the soft material provides more variability and form for the connection. For the following chair(see Figure 20), foam seat cushions are fixed through the solid oak chair legs. A but-



Fig 20 Buckle of Jed Armchair for Habitat (Irvin, 2011)

toned epaulette and passant detail would allow the cushions easily to be removed (Irvin, 2011). The advantage of the soft buckle is that it is user-friendly and safety.

The buckle is also seen in combining leather with a wood connection. Below is the Børge Mogensen Hunting Chair (see Figure 21) which is created around 1950. The frame is made of oak



Fig 21 Børge Mogensen Hunting Chair (Mogensen,n.d.)

while seat and back are of leather with adjustable buckles. The adjustable function is achieved by the buckle connection, which adds more detail for the design.

2.2.5 Wood-to-Glass Connection

When referring the wood to glass connection, many people would think about the table. Indeed, this is the most familiar application of that type of connection.

Horizon (see Figure 22) is a table made with American black walnut wood and toughened glass (Ness, 2013). The unique area is the way the glass combined with wood. Most of the glass is rested on the wood legs. For this table, the toughened glass is inserted in wood frame, a groove is made to fixed the glass, which shows a clean connection.



Fig 22 Table of Horizon (Ness, 2013)

When looking at [etsy.com](https://www.etsy.com), the researcher found a similar design, which named the The Evans Coffee Table (see Figure23). The table's most attractive area is "floating" glass top (Cox, 2013). It is designed to give it a perfect visual balance to complement its surroundings.



Fig 23 Evans Coffee Table (Cox, 2013)

This type of connection is not limited to the wood-to-glass connection. If a table is manufactured with metal and glass, the connection type could be similar. The Vintage Coffee Table (see Figure 24) is manufactured with tempered glass and polished steel. This type of connection looks clean because there are no hinges, screws or nails. Compared with the normal table design, the “Vintage” seems supported just at one side. One creative point is that the 45 degrees polished steel base could help the top glass to satisfy counterbalanced

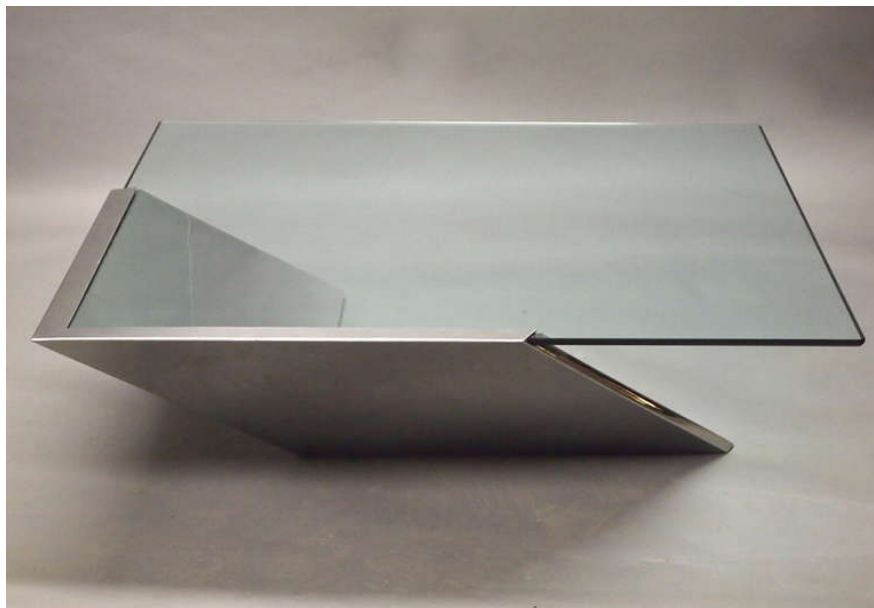

Fig 24 Vintage Coffee Table (Beam,1970)

From analysis of the cases above, it is supposed that most of the glass is manufactured in sheets with different thickness, the connection is probably fixed within a groove or sunken in another part.

2.2.6 Wood-to-Multiple Material Connection

There exist connections that are made of three materials, and wood is one of the materials. This kind of connection could be named a second physical connection because there are two

connections close together. Common types of such kinds of connections are wood-metal-soft material connection and metal-wood-metal connection. This section will analyze a number of examples of these connections.

A portable seating design called “Carry On” (see Figure 25 & 26) is a typical example of multiple material connection, with white pigmented oak and a casted fitting in zinc and fabric.”Carry On” is designed by Mattias Stenberg. The author was attracted by the top handle even if “Carry On” seems to be have a very flexible appearance at the first glance. The handle conveys the user how to use the product very clearly through its rounded form and two metal pieces.



Also, “Carry On” demonstrates a good craftsmanship which will leave a reassuringly sturdy and reliable impression.

Fig 25 Handle of” Carry On” Portable Seating Solution (Stenberg, n.d.)



Fig 26 “Carry On” Portable Seating Solution (Stenberg, n.d.)

Another type of connection is made of leather, wood and brass. An example of this work was made by Phloem Studio in 2013. Inspired from a sling chair, the Peninsula Chair (see Figure 27) is a lounge chair made of a leather sling attached to a wood frame with brass rods (Klebba,,

2013). From the introduction of the Peninsula chair, it is easy to understand that the metal rods serves as a bridge to combine the wood and leather to achieve interchangeability of the sling.



Fig 27 Peninsula Chair (Klebba, 2013)

2.3 Considerations of Physical Connection Design

According to the analysis of the current physical connections, several considerations were mentioned in physical connections such as the relationship between the form and function, and it is supposed that connection design is expected to be simple (i.e. metal-to-wood connections). Based on the analyzations and summaries of the previous chapters, four types of considerations will be given are:

- Form Follows Function
- Simplicity

- Safety
- Balancing relationship between the technology, material and aesthetic

2.3.1 Form Follows Function

Nearly all the types of typical connections previously discussed demonstrated the relationship between the function and form. The relation between form and function was the one that was most referred to in previous research, and it was emphasized that design involved both of them. (Digerfeldt-Månsson & Venkatesh, 2005) “ Form follows function ” means that the first job of a designer is to make sure that the design functions as it is intended. This guiding philosophy came from the American architect Sullivan in 1914, when many famous buildings in Chicago were created according to this design philosophy. He built the the relationship between the shape and function by pointing out the order. This philosophy is not limited to the architecture field, it was quickly accepted by many people of industrial design field. Digerfeldt-Månsson and Venkatesh (2005) mentioned that function has a dominant position in industrial design and the derivative role of form which ultimately serves function. Digerfeldt-Månsson and Venkatesh emphasized that the function is the primary factor that required to be considered.

In turn, form or shape can reflect the function. The shape of a product influences how it can function, but a specific function also requires a certain shape (VanKesteren, 2005). VanKesteren’s opinion expressed the subtle relationship between function and form. We might notice that the most rotational function needs a round shape (i.e., mouse wheel). Creusen pointed out in his article that the utilitarian functions of a product can be directly obvious from its appearance (Creusen, 2007). When certainly seeing a connection, you know the product can rotate.

“Form, however, could not be reduced to a mere representation of function as held by the functionalistic design ideology ‘form follows function’” (Digerfeldt-Månsson & Venkatesh, 2005). In addition, product appearance can be used as a cue to infer more important but less readily accessible product attributes according to Berkowitz’s (1987) and Dawar and Parker’s (1994) research. (Berkowitz, 1987; Dawar and Parker, 1994).

When discussing physical connections, the philosophy “form follows function” works effectively. From Ashby and Johnson’s (2009) point of view, “deliberately highlighted joints are used as decorative motifs, often to emphasize the function of the product”. People could identify the physical connection from the corresponding forms.

For some dynamic physical connections, this philosophy is demonstrated more clearly. For example, a big rounded shell machine with plastics, is an expression of precision technology that implies it can support and rotate very smoothly (see Figure 28). The contrasting black color also helps the form to highlight that this connection is used for mechanical support. Assuming that a very thin screw replaces the plastic circle, will it maybe give consumers the impression that this product is loose and not durable?



Fig 28 Strollers for Stokke (Holmqvist, 2012)

Another example is made off soft material. The handle is a movable handle. The rounded boundary of the leather implies the function.



Fig 29 Helsinki Loudspeaker (Vifa, n.d.)

2.3.2 Simplicity

Today, both traditional product design and interaction design are becoming more simple in functional and aesthetic perspectives. Technology enables us to multitask using the same devices. We type, we speak, we see, we play and operate on the same iPhone screen. Functional features are optimized to be integrated in one simple five-inch square. When the iPod was introduced, it lasted for just a short period, and then it was replaced by smart phone because of the iPod only had the simple music function. As Hekkert mentioned in 2006, “If we can smell, see, hear, or decide something faster or with less effort, we will prefer it over the more demanding alternative”. This is summarized in the principle of “maximum effect for minimum “means. Simplicity does not just benefit for users, but also helps the producers and marketing people to sell as well. Lucule’s brand and culture strategist Kaye (2013) discussed that simplicity is the secret to achieving successful product design. Apple’s Macbook is a successful example. The obvious difference of the Macbook from other laptops is the body appearance. The whole body is molded at one time,

so there is no extra parting lines and mechanical connections in the shape. Kaye (2013) thought for product or message, the more quickly customers understands, the greater chance to sell to the people. Apple’s white ear buds is a great design to explain that. Simple shape implies to the user clear function without extra explanation through other channels.

Likewise, this principle can also be applied in the physical connections in product design. Kaye (2013) added a fact that “people spend at most three seconds at the retail shelf, meaning they do not even see text, much less read or understand it”. This kind of phenomenon also happens in the furniture industry. People prefer to use furniture which seems easy to use and easy to disassemble. Functions are achieved by physical connections at great extent. So simplicity is required for physical connection design. If one connection can achieve more than one functions at the same time, it is visually simplified, and therefore accepted and preferred by the consumers. Kaye (2013) pointed out “more elegant and straightforward design” will make it easier to win customers. If designers can achieve the same function in one material and uses less mechanical parts (i.e.,hinge), it would be visually more attractive for people.

2.3.3 Safety

From Ulrich ’s (2006) point of view, designers benefit “from understanding that humans are likely to be attracted to things that appear safe and stable, and that this perception is based on the physics of pretty ordinary objects made of materials like tree branches and rocks”. This opinion can be clearly evident in product design, especially the furniture category. We know that the round shape is preferred for a table in order to avoid sharp edges as a safety issue.

Below is a table called “Nora Table”(see Figure 30), and its description:



Fig 30 Corner of “Nora” Table (Nora, 2009)

“The table has a chamfered edge to create a softer interface between the product and its users. This chamfer then also creates a natural connection between the tabletop and the legs.”(Nora, 2009.)

The product description contains the term “softer interface” and “natural connection.” Imagining a situation when sitting at the table, at the first glance, “Nora” may suggest a safe and soft feeling. And then when sitting at the table, the user’s legs do not frequently touch the inside edges. The round shape provide visually safety and actual physical safety at the same time. Thus, the inspiration of “Nora” is not only from an ergonomic factor, but also from an aesthetic consideration. Humans assume “normal physics” in evaluating objects, so chairs, tables, other structural objects are and more likely to be attractive if their forms appear to be stable, solid and strong (Ulrich, 2006). Another existing design illustrating is a library stool (see Figure 31). Hidden casters enable more stability and safety for users. Even if there are variations of the shape of the library stool, the basic circular truncated core maintains the similar structures.

Another furniture example is a bar chair called “Lunar Bar Chair (see Figure 32). The



Fig 31 Library Stool (Barber, 2012)

dimensions are 600mm wide, 508 mm deep and 1057mm high. A user of the famous design web-site [pinterest.com](https://www.pinterest.com)



Figure 32 Lunar Bar Chair (Stellar, 2011)

Alayna Mackiewicz (2014) gave the reason why she did not like this chair, “I picked this bar

chair because it looks very top heavy. It is more weight at the top than the bottom and the legs and support look very small in comparison. Forms can be unstable or top heavy; these are easy to tip over and appear that way.”

Some people may argue that modern furniture design, including some optimal unstable chairs, could enhance visual interests for the design field (see Figure 33). For example, in recent Milan Furniture Shows or other furniture exhibitions, some new concepts similar to the below



Figure 33“Paint or Die But Love Me” Table (Squee, 2008)

table were introduced, but this kind of furniture is more likely to be seen in exhibitions rather than in people’s homes, often for reasons mentioned by Mackiewicz.

The physical connection of the table has an extra triangle face which has an unclear purpose at first glance. However, after knowing the philosophy that people are attracted by objects that are visually stable and safe, the triangle face makes more sense. In order to provide more safety, the designer might create an extra transition face to reduce some sharp collisions. This could be called chamfer. On the edges of the legs, is much smaller fillet, which will also provide safety for the user.

Another example of connection is also a table (see Figure 34), which is made of wood and metal. The top part is inserted into the metal foot, and fixed by mechanical screws. One interesting place is the area where the two touch. This has a rounded shape. This area does not have a smooth transition, so it might be easy for people to run into. The round shape will help people avoid bad collisions.

The safety consideration is not only applied fur-



Fig 34 Triangle Connection of Plywood Table(“Plywood”, 2000)

niture. If a product has user interaction, the designer should consider all kinds of similar situations. For example, one bad structure is the metal hinge inside the umbrella. According to the author’s personal experience, the hair often gets stuck inside the hinge, which usually cause a safety issue.

2.3.4 Balancing relationship between material, function and aesthetics

One reason which causes complexity in selecting a physical connection is technology and material limitations. This is a frequent occurrence. No material or technology is perfect. When making decisions about selecting material, product designers need to consider the aesthetic factor more.

One successful brand is IKEA, whose design philosophy is defined as good modern design by Kaufmann (1950). Kaufmann was responsible for the design collections at the Museum of Modern Art (MoMA) in New York. In MoMA's booklet, the definition of modern design in the 1950s was expressed by "*What is modern design?*" Kaufmann wrote that 'modern design' should display ten principles. In that principles, more than half of them are related to the subject aesthetic, material and technology. For example, he mentioned that the designers should "take advantage of new materials and techniques" (Kaufmann,1950). This reminded the designers to pay attention to the new materials and techniques. He added that visually satisfactory could gain from mixing the expression of utility, materials and process (Kaufmann,1950). It is conclude from the Kaufmann's principles that visual satisfaction could be improved in harmony with the relationship between the function and material. Kaufman (1950) emphasized that material and technique selections are important to satisfy the customers' requirements, he says, "develop the forms, textures and colors that spring from the direct fulfillment of requirements in appropriate materials and techniques" (Kaufmann,1950). From the discussions above, it is no exaggeration to say that the secret of the IKEA is related to balance the technology, material and aesthetic.

"Each material must be used in ways that expose its strengths, its natural appearance, and its intrinsic qualities" (Ashby& Johnson, 2009). Ashby is not the only person who pointed out the right way of material selection. Kaufmann (1950) stated the similar opinion in his book"

what is modern design”. He says, “express the qualities and beauties of the materials used, never making the materials seem to be what they are not”, he thought that designers should use the material to express the beauty appearance and good quality, not just express the material’s natural appearance and property. One classical example could be provided to explain Kaufman’s opinion is “Lindeberg Titanium Case”. In 1996, Lindberg won that year’s “If Design Award”, with a special shape of glasses case (see Figure 35). This case is made with titanium. The design use the elasticity from the titanium it self to achieve opening, so there is no extra structure exposed. The beauty of the curved shape was successfully exposed by the titanium property.



Fig 35 Lindberg Titanium Case (Lindberg,1996)

Ashby&Johnson (2009) pointed that Material properties may restrict the shapes that are possible, for example glass has a limit in thinness and elastomers can not form sharp edges.

Materials have different properties that limit the smoothness of a surface (Ashby& Johnson, 2009). In contrast, this imperfect would bring more opportunities for designers. Because limitations enable designers to create more different materials that have influence on shape. The technical requirements to the the product impose certain constrains on shape. For connections

that are combined with different materials, visual effects would be different, then the aesthetic would be different. Different material will cause different visual effects and express different feeling. Special texture of wood remind people of hand craft. As Ashly and Johnson (2009) pointed out in his book that carved wood or polished wood suggest craftsmanship. Wood always represent the classical style in furniture design. If daily objects are made with ceramics, it suggest elements of luxury or extreme performance requirements (Ashby& Johnson, 2009). High-reflect surface and pure color makes the objects look clean and comfortable. Metal is an identifiable material which is easy to be recognized by people. But polymers can in “appearance-as-sume” the character of almost any material: in particular, they can be made to simulate wood, metal or other materials {Ashby& Johnson, 2009}. Similar discussions were given in previous when talking about the wood-to-plastic connections. It is supposed that plastic could not only replace the metal, it could simulate other materials.

Connection area of product could be used to express the designer’s material exploration. The thinking and innovation of material could be noticed from the connecting area of a product. Designer Hunn Wai’s Wood X Plastic' shelf (see Figure 36) demonstrated his thinking of material. The most unique feature is there is no interstitial material and gap between the wood and acrylic. At the beginning, a little hole is made in the acrylic sheet and is heated by controlling the time, and then wood pole was pushed through the hole (Keane-Cowell, n.d.). There is o extra fixed screws or nails of the joint, sturdy and rational structure was created by contracting around the hole during the cooling time.

One common connections between the table plate and legs can be a good example. Wood-to-wood combination is easy to manufacture, and it is usually created by individuals and

traditional handcraft workshops, which enable designers more flexible for aesthetic elements. Visually the connection is often concealed (see Figure 37).



Fig 37 “+” Table (Williamson, 2013)



Figure 36 Detail of “Wood X Plastic” Shelf (Keane-Cowell, n.d)

The plastic to wood connection is more noticeable, the contrast between the material and color is



obvious. (see Fig- *Fig 38* 3D Printed Connector “Keystones” (Prindle, 2014) *ure 38*)

For connections that are combined with metal and wood, it is hard to manufacture, metal-to-wood connections might give the customers the impression of stable and heavy. And it is less flexible for the shape and aesthetic. Straight lines and the relatively sharp corners might be the common pattern in this kind of connections

3 RESEARCH

3.1 Research Method

Several research methods such as design structure matrix analysis, graphical model and radar chart, will help to classify the research and analyze the relationship between the variable factors. Each of the research methods will be discussed in the following sections.

3.1.1 DSM Analysis

Design structure matrix(DSM) is a mature analysis methodology for design field. Eppinger and Browning (2012) pointed in their book “Design Structure Matrix Methods and Applications” that “DSM” is a “simple, compact and visual representation of a system or project in the form of a square.” From the DSM model, the researcher could find the differences between the elements quickly. As Eppinger and Browning (2012) mentioned, the model is easy to read, and highly compact because of the way results are “displayed in a graphical format”. From the matrix, people could quickly differentiate the elements by examine strength interactions quickly. For these reasons, the “DSM” models will be used to analyze the classification words to confirm that the intuition that some elements are linked and that some words co-occur with others with both greater and lesser frequency. In this study, the “DSM” model is used to analyze the relationships of the different physical connection categories. For example, the contrast material seems to have more interaction with other certain words, such as revealed connection, and form transition among others.

3.1.2 Qualitative research & Quantitive research

In order to get the designers' ideas on classification and their understanding of the connections between elements, a survey was conducted among product designers. Because the topic is subjective, participants have to describe the connections given, so connections are hard to deduce. Thus, the researcher decided to use the qualitative research. By observing behaviors and talking with designers, the researcher might gain a deeper understanding of the complex classification of physical connections. Compared with quantitative research, qualitative research allows the participants to say what they feel and think. It also allows the researcher to obtain more insights into the problem directly.

3.1.3 Radar Chart

Radar charts are a useful way to display multivariate observations with an arbitrary number of variables. The researcher mentioned previously that there are several multivariate factors such as structure, material, and connection type that will affect the physical connection, in order to record and analyze how participant classified one physical connection example, a radar chart will be used to describe and compare the differences between physical connections. Radar charts will be a suitable way to describe and analyze the whole system.

3.1.4 Graphical model

A graphical model or probabilistic graphical model (PGM) is a probabilistic model. They can provide a fully probabilistic interpretation to many neural network architectures. (Jordan, 1997) It has a strong interpretability of the relationship between the elements. Also, the graphical model

is not limited for describing and analyzing the current network systems. It could be used for a new system.

3.1.5 Classification

Ashby pointed in his book that classification is important in design field (Ashby&Johnson, 2009). Design has a close relationship to select, and selection from the data is closely linked with indexing. Relatively optimized data can help designers find useful references and inspirations quickly. Ashby & Johnson (2009) added that classification is the the first step in bringing order into any scientific endeavor. Classes can be defined in different ways (i.e.,function), no matter how it is classified, it should help designers find the help deliverables quickly.

3.2 Research Procedures

Before initial analysis, a large amount of image resources were selected randomly from pin-terest.com based on searching related key words such as wood joint, furniture detail, kitchen appliance joint, wood-to-metal joint, furniture joinery, product detail, different material connections, form transition, etc. In order to cover a wide range of products, this research collected in total about 100 examples from furniture and consumer products, the soft goods and other type of products. In order to give the participants a relatively comprehensive understanding of the physical connections, some physical connections are provided



Fig 40 Classified Notes on Black Board

more than one perspective view to help people easier to focus on the connection and reduce the confusion of the image.

Before utilizing surveys, the researcher classified these connections based on previous analysis and playing with the images at black card board (see Figure 40). To begin with, there are four basic types of connections. By four basic types of connection system were created: concealed connection, revealed connection, feature connection and form transition. Sub types of these basic connections were also identified and illustrated in Table1.

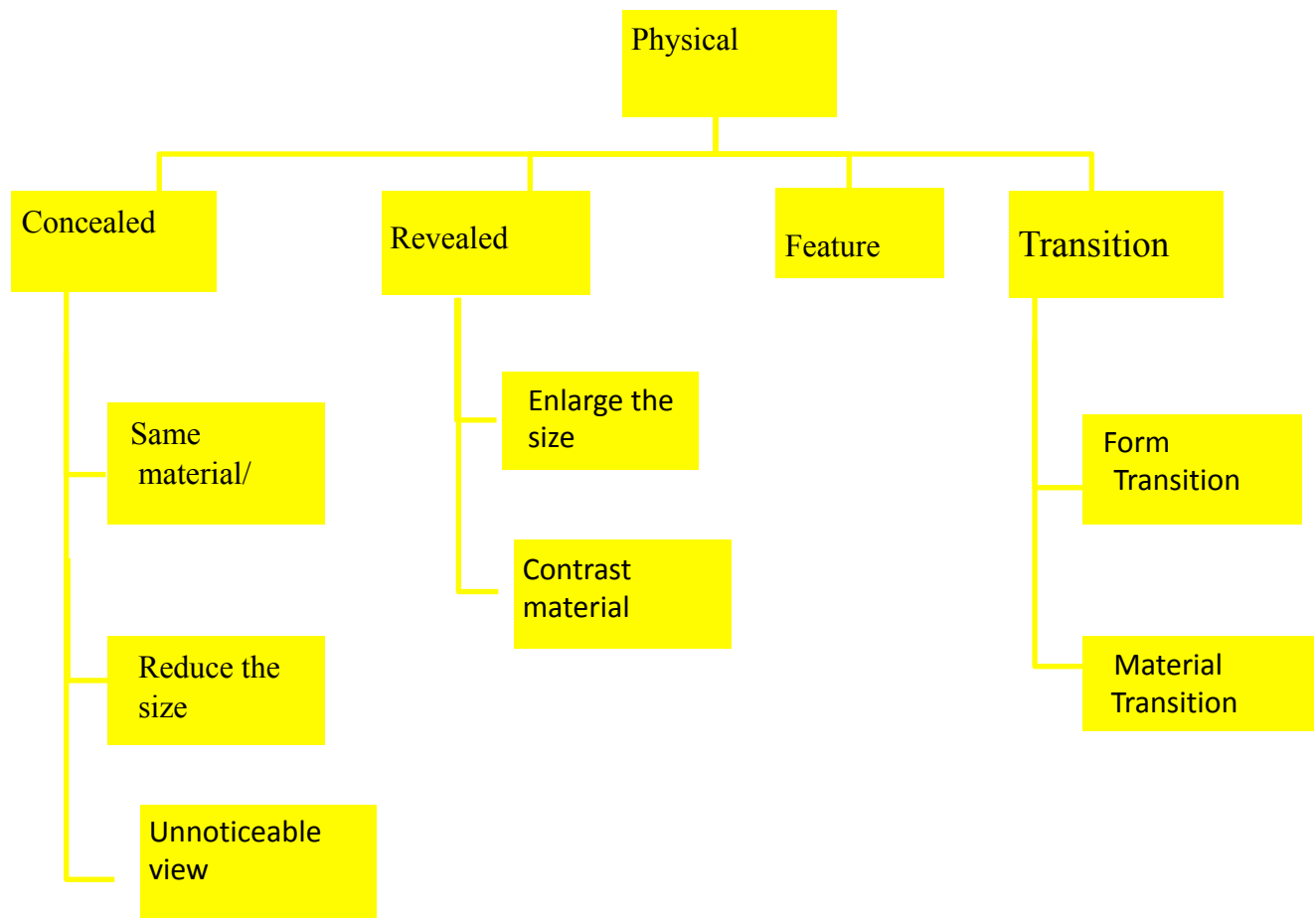

Table 1 Basic classification of physical Connection

After careful thinking with the above classification system, overlaps between the revealed

and feature has been found. It is difficult to define the boundary of these two types of connections. Plus, these four types of connections could not include collected connections, there still exist several connections do not belong to any of the provided types. A qualitative research needs to be conducted according to the situation.

Due to limitations of the resources and time, 20 designers in southeastern United States were asked to participate in research with 16 of them completing the project. Ten participants finished by face-to-face, while six designers people responded by email due to long-distance. For face-to-face survey, all the participants spent the whole research between one to two hour, and completed the survey more than once. In order to get feedback from different groups, the researcher interviewed different group of people (see Table 2).

	Undergrad student	graduate student	Faculty	Designer
Female (F)	4	2	0	1
Male (M)	3	2	2	1
Sum	7	4	3	2

Table2 Demographic of Survey Participants

In order to get consent from subjects, the researcher followed the below steps to ensure subjects be aware of the proper risks and understood the research plan.

- The researcher invited the industrial design students and faculty by explaining the motivation and object of the research. They could choose to participate in an on-site survey or through email.
- By pointing out how long the research will take, the researcher would like to involve partici-

pants who are really interested in this topic because a longer time commitment will reduce their empathy thus affect the survey.

- In order to get close to the survey, the researcher will take a qualitative interview with participants who are willing to take on-site survey and an audio recorder was used to record their comments for deeper exploration and analysis.

Before the survey started, the researcher played with the images in the black board.

Then analysis came up with the eight categories for the images:(see Table 3):









Material Transition	Form Transition	Intersect Different Pieces	Enclosure	Revealed	Concealed	Groove	Contrast Material	Others/ No idea
								

Table 3 Labels provided in Survey

Material Transition; Form Transition; Intersect different pieces; Enclosure; Revealed; Concealed Groove; Contrast material and Others/ No idea

The research decided to put a large image poster on the wall (inside of School of Industrial and Graphic Design of Auburn University) and disordered the images (see Figure 41) and let the other participants play with the images together. Then participants chose the category titles provided the by researcher to describe the connec-

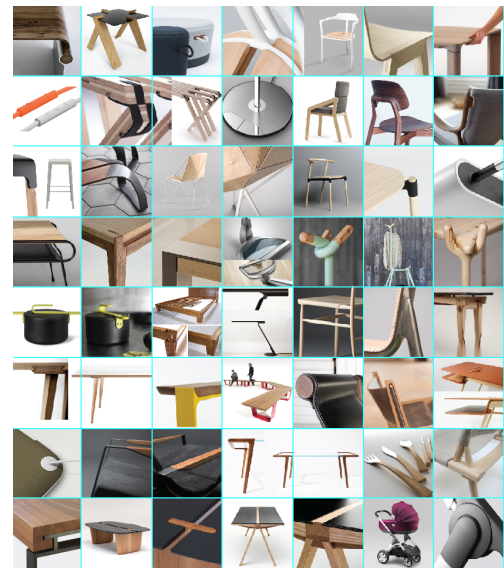

Figure 41 Survey Poster Layout

tions based on their first impression. Participants were allowed to pick more than one for each connection. Also they could create their own words if the given words did not match what they saw. Participants could return multiple times to finish the survey.

For those participants who were willing to take a survey online, they will finish the survey via illustrator software format by email (see Figure 42).

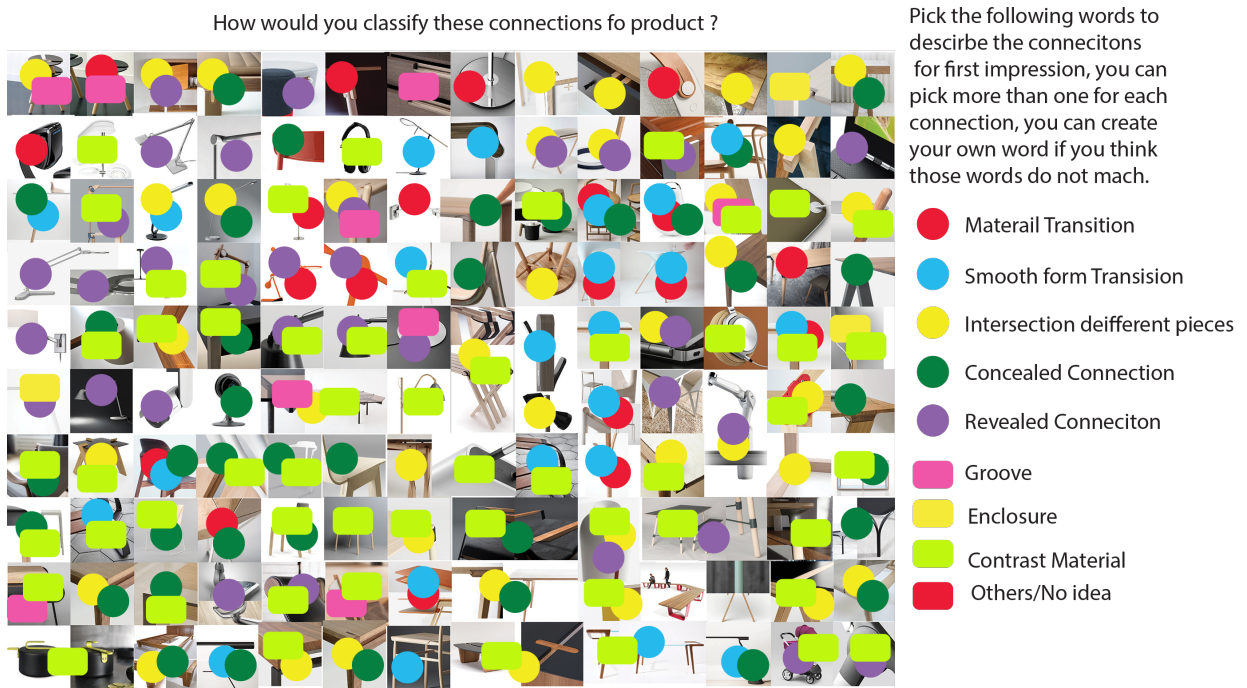

Figure 42 Email Version Survey

After completing the survey, the title has been raised more than half which are:

Interlock ; Texture Transition ; Hinge Style ; Nested ; Pierce ; Rotational

Hardware connection (see Table 4)

















Material Transition	Form Transition	Intersect Different Pieces	Enclosure	Revealed	Concealed	Groove	Contrast Material	Others/ No idea
								
Interlock	Texture Transition	Hinge Style	Hardware	Nested	Pierce	Rotational		
								

Table 4 Labels Used in Survey

3.3 Research Conclusion

The qualitative research study took the researcher about four weeks collect enough information and analyze the data. Through the whole research, several interesting and satisfied findings in different aspects impressed the researcher. Apart from the general findings about participants' behavior, it is supposed four dominant types of classification method could define a physical connection relatively precise which are:

- Appearance
- Connection Type
- Structure
- Material

Among these four aspects, material is identical before the research, it would not be discussed any more.

3.3.1 General Findings

Observation: If more than one connections exist in product, the connections with contrast material/color, larger size, and dynamic function are the dominant factors which capture people's eyes firstly. The below floor lamp (see Figure 43) has at least four physical connections. Of the participants,80% choose the middle connection to classify. Above half of them ignored the other connections entirely.

Interpretation: This phenomenon did not happen only once, but several times during the alive survey. From the participants' neglect of some connections, it is supposed that there exist visual order behavior in these situations. People are sensitive to objects or areas with visual contrasts, such as proportion, rotation, color and material. These words m cause the connections revealed from the product. In turn, if a designer would like to build a revealed connection, he/she could highlight the connection by using a contrastive material/color or enlarge the proportions of the individual parts of the connection.

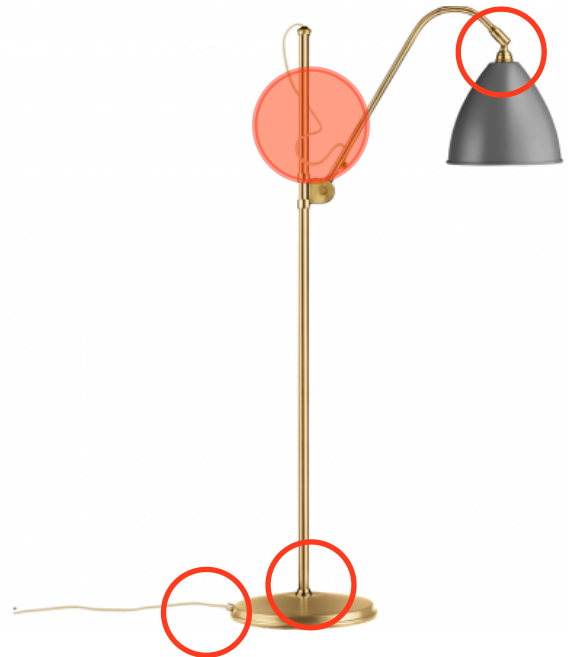

Fig 43 Gubi Bestlite BL3 M Floor Lamp (Dudley,n.d.)

Observation: Nearly all participants used more than one labeled words to define the connections shown in the survey. Most images have more than one description, with one participant even using four titles to describe one connection at the same time. Below is a matrix that showing the category labels that has been used together (see Table 5).

	Material Transition	Form Transition	interact pieces	Concealed	Revealed	Groove	Enclosure	Contrast Material	Interlock	Texture Transition	Hinge	Hardware	Nested	Pierce	Rotation
Material Transition	✓	✓													
Form Transition	✓	✓	✓					✓				✓			✓
interact pieces		✓	✓		✓			✓	✓						
Concealed		✓		✓			✓								
Revealed			✓		✓			✓			✓				
Groove						✓		✓							
Enclosure			✓	✓			✓	✓							
Contrast Material		✓				✓		✓	✓						
Interlock			✓					✓	✓						
Texture Transition										✓					
Hinge					✓						✓				✓
Hardware		✓										✓			
Nested													✓		
Pierce														✓	
Rotation		✓													✓

Table 5 Matrix of Physical Connection Classified Labels

Interpretation: It seems people would like to classify physical connections provided more precise. Compared with other words, the form transition, the intersections of different pieces and the contrast material are the words that have more interactions with other words, which means these kind of types such as form transition, the intersections of different pieces and the contrast material are very common seen and, they are easy to be differentiated for the participants.

Observation: For some connections, people have very distinct opinions about classification. They tried to classify these connections in different ways. For example, the connection of the “Simple Table “ (see Figure 44) is described as form transition, intersection of different

pieces, contrast material, material transition, enclosure, revealed connection. Although it is hard to get consensus from the participants, more than half of the participants admit that this connection is visually attractive. It is made up from bended wood and cast aluminum. The survey result could be seen from Table

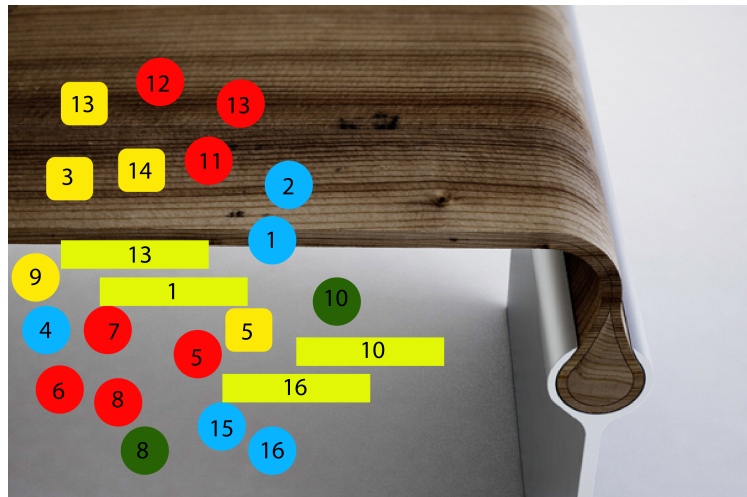

Figure 44 Survey result of “Simple Table” Connection (Knebel,2009)

7. From the result, we could see that seven participants use “material transition” (red dot label) to describe the area, four participants select to put the contrast material (yellow strip label) and enclosure, five participants thought the area is a good example of form transition (blue dot), one

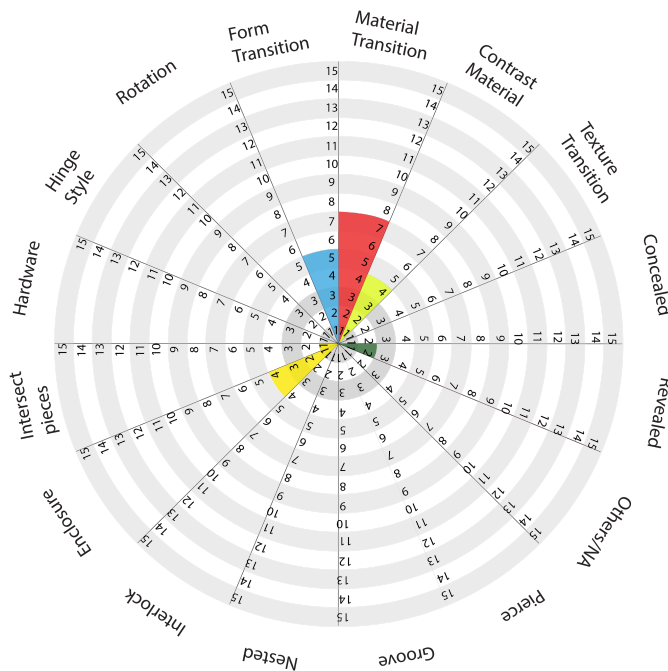

Table 6 Classified survey result of “Simple Table” physical connector

participant thought two parts interact (yellow dot) together and two participants pointed out the revealed (dark green dot) form transition in this area.

Interpretation: For some connections, people tried classify in different ways. In the above table, it is supposed that participants considered the material, the form, the structure (the way they connect), and connection type. If more people would be involved int the research, the result would be more precise and more clear difference of these factors would be noticed. From the re-search observation, different people paid attention to different factors. No matter how hard to describe the connection, if one could classify the connections in more different aspects, it could be more precise.

Observation: When participants put concealed connection and revealed connection for the same connection (see Figures 45 & 46), for rotational connections and also fixed connections.



Fig 45 Connection of Floating Console Table (Mckenzie, 2015)



Fig 46 Tube Desk lamp (Giessler,2010)

Interpretation: This phenomenon did not happen for just once and for certain participant, which means concealed connection and revealed connections could be used at the same time to describe for one connection We could say that concealed and revealed were not absolutely oppo-

site in this situation, so this connection could be described at the same time. For the furniture below (see Figure 47), the scroll itself is revealed because of the contrast material and color used, but the connection is hid at the inside corner, which causes the connection to be invisible and



Fig 47 Plastic Connection of “ADD System” (Etherington, 2013)

concealed of the whole furniture.

Observation: Participants mentioned that they had no idea how to describe several connections provided, because they could not find the appropriate words given in the survey, and also it seemed hard for them to find words to describe. Below is a design called “ Bottle Humidifier” (see Figure 48), which could be powered by USB. Most participants noticed the plate between the bottle body and the cord, and above half of them had no idea how to describe what they see. Participant 7 told the researcher that one connection is an accidental design (See Figure 49), this happened just in special condition and it that accidental connection was hard to applied to others. She admitted that some connections could be described as design highlights, which might have a positive impact on product de-

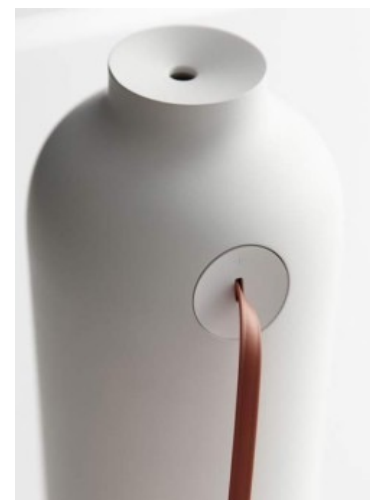

Figure 48 Bottle Humidifier (Yoo,2011)

sign.



Figure 49 Connection of “63 Grad” Bench
(Barkschat & Blumel, 2012)

Interpretation: Physical connection design is part of the product design, serving the product for many aspects such as function, form etc. Although a physical connection is almost a mechanical design, it still belongs to the product design. From the aesthetic perspective view, designers are encouraged to create fresh and original physical connections, to make the product more competitive in the market. As mentioned in previous chapters, physical connection design could be used as an area to demonstrate designer’s personal statement and material exploration. So it is not strange that some connectors are created accidentally and most people are unfamiliar with these new, fresh connections.

3.3.2 Form Transition & Material Transition

Observation: For some cases, when more than 80% participants put the "form transition" title to describe the connecting area, there seems no hesitation when they decided to use the label

form transition to describe what they see. When they were asked to describe what was ‘form transition’, most people could find an example quickly and they pointed out how the form changes in different images. Form transition labels are accompanied with contrast material labels and material transition labels. But participants put the form transition label before other words. During the survey, two participants found that there are several images that could not be described as a smooth form transition, because they pointed out that the transition is sharp and change abruptly. One participant created ”form contrast” and another participant created “ form change “ to describe that kind of abrupt transition.

Interpretation: Form transition is an obvious title for designers. From their point of view, form transition is commonly applied in product design, and often seen in many kinds of product designs. That is why designers are sensitive to form transition. Several people unconsciously thought form transition should have a smooth transition. Actually, form transition can be smooth

or abrupt form transition (see Figure 50), so the labels form contrast and form change from the participants could also belong to the form transition, with the only difference the transition degree. Another finding is that a welding connection is almost a form transition because of the



Fig 50 Detail of Joy Table (Acro, 2014)

way it manufacture (see Figure 50).



Fig 51 Welding Connection of Milanese Chair (Diez, 2013)

Observation: Some participants were confused with the term "material transition." From their point of view, material contrast is a more precise word. And some participants use both the form transition and material transition to describe a connection. From the Oxford English Dictionary, transition is "a passing or passage from one condition, action, or (rarely) place, to another; change". In the researcher's opinion, the following area could be defined as material transition, which exists as the third part between two contrast materials. Although participants are confused with the material transition, the participants did not create their own labels except for participant 11. He explored two specific words to describe the connection: color transition (see Figure 52), texture which might convey more clearly the actual transition.

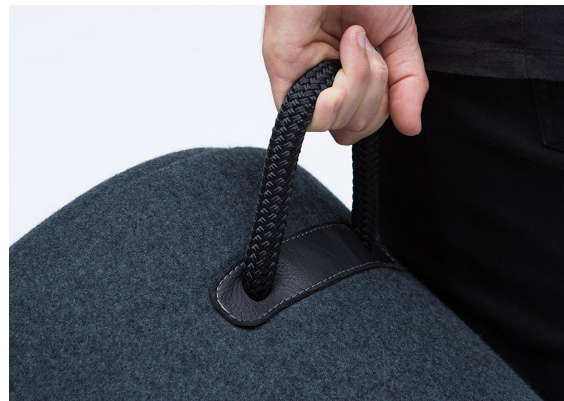

Fig 52 Duffel Stool (Webber, n.d.)

Interpretation: Compared with form transition, material transition is not a precise word. By the fact indicated that the material transition is not a right word to convey what participant number eleven

would like to convey. As a whole, participants pointed out there is something more than just form transition, but it was hard for them to describe in a term.

3.3.3. Physical Connection Type

Observation: For dynamic connections such as rotational connections, more than 2/3 of people noticed the dynamic types at the first glance. They paid attention to the connection area and how it works, they thought most of the rotational joint is revealed. Participant number eight said most rotational connections have a better semantic communication than fixed connections, and he said he would like to redesign some of the bad examples of the static connection (see Figure 53).



Fig 53 Wood Handle of “Handle Me” (Aarseth & Angell, 2012)

Interpretation: It is needed to differentiate the connections with a static section and dynamic section. Connection Types have different values in different types of connections. Compared with most of the static connections, dynamic types contribute more values. There are several reasons that people felt rotational connections communicated the function better. At first, when the people concentrate on static connections, the structure and material feature captured

their attention. For dynamic connections such as rotational and slide connections, people were interested in the moving scale and how the connection could work. Another reason is that most of the rotational connections are revealed and the function is emphasized by form and material(see Figure 54).



Fig 54 Connection of Mamet Lamp (Carballal,2015)

3.3.4 Structure

Observation: People like the connection type intersection of different pieces. Large numbers of connections of wood-to-wood (see Figure 55) could be described as intersections of different pieces. Participant number three thought that more decorative details showed in wood-to-wood connections. During the research, participant number eleven pointed out that there were two types of intersections, first is that one part extended and



Fig 55 Traverso Table (Faccin, 2012)

one part come through from another part (see Figure 56), the second is two parts intersect at one point and stop at that point (see Figure 57).

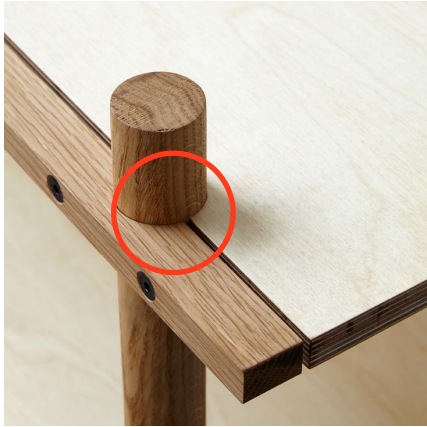

Fig 56 Connection of Butty Shelf (Butty, 2015)

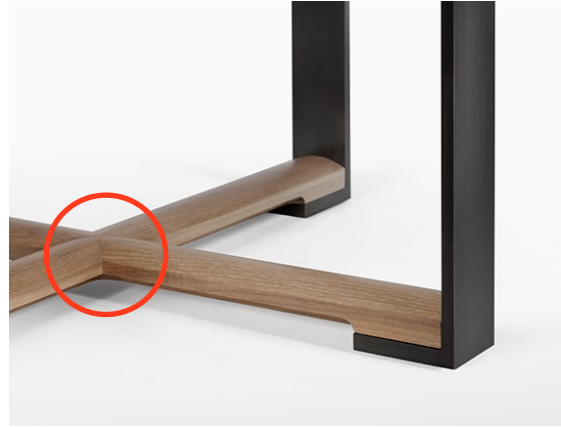

Fig 57 Connection of Madeline Table (Hunt,2016)

Interpretation: From the Oxford English Dictionary, the word “intersect” describe an act “to divide (something) in two by passing through or lying across it; to cross. Freq. in passive (const. *with* or *by*)”. In geometry, intersecting lines means the pair of lines, which meet each other at one point. This means that if two or more lines meet at a point, this point is called “Intersecting Lines”. We see all kinds of real intersecting lines in our daily life. At this point, it is easy to understand why so many wood connections could be described as intersecting off different pieces because most wood-to-wood types are connections that made up more than two parts intersect with each other.

Phenomenon: During the survey, the researcher found participants nearly had no hesitation to select the enclosure label title, they did not need to think too much for term “enclosure”. Several participants found that there were at least two types of enclosures. These two types of enclosures are differentiated how deeply one part is enclosed. One type is entire enclosure (see

Figure 58). It is concluded from the corresponding survey result (see Table 7), that above half of the people select the enclosure, it could be the dominant factor among other factors such as con-

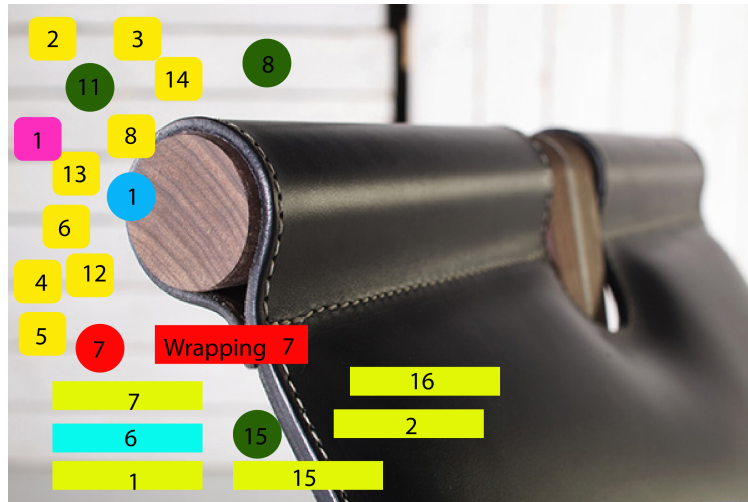

Fig 58 Armada Armchair (Jedrejic & Ugresic, 2014)

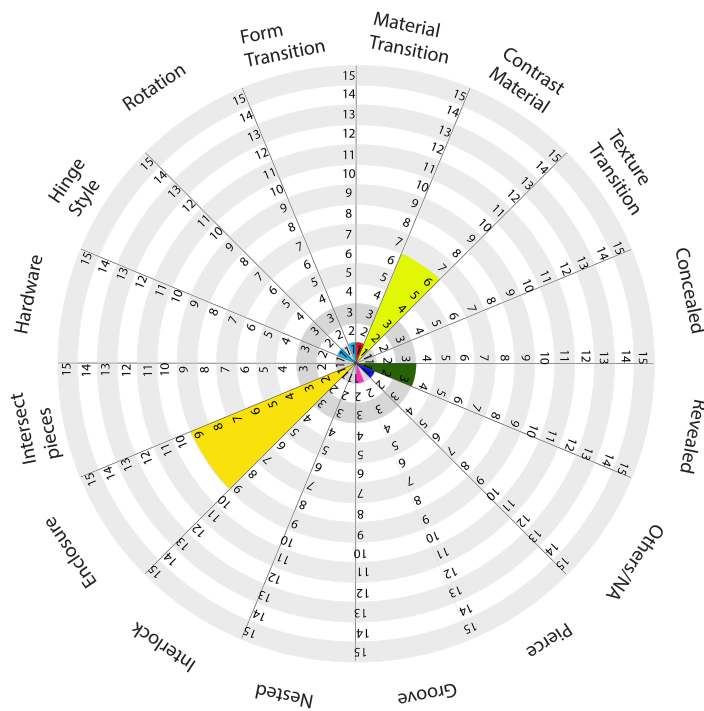
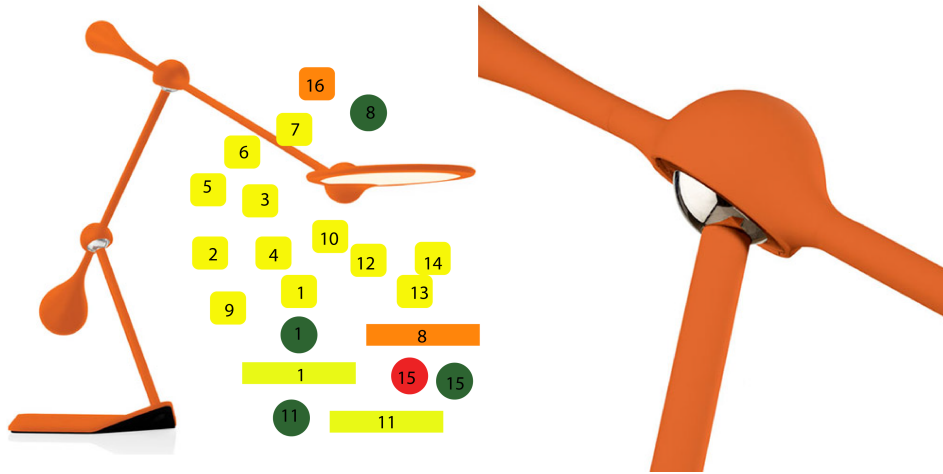

Table 7 Survey Result of Armada Armchair

trast material label, revealed label and so on. Participant seven created another word wrapping,



she thought this could replace the enclosure. Another type is semi-enclosure (see Figure 59)

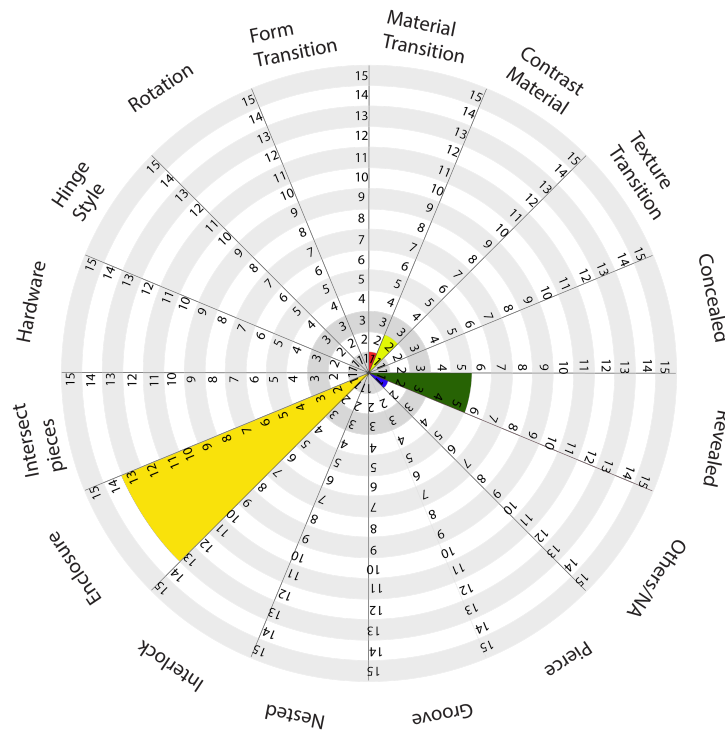

Table 8 Survey Result of Trapeze Large LED Table Lamp

One participant thought there are more semi-enclosure connections than the entire enclosure connections in our daily life. The corresponding result table (see Table 8) showed that twelve participants decided to select the enclosure label. Just few other labels came out from the research result were rotational connection, revealed connection and contrast material.

Interpretation: From the above research result, the author found that above half of the participants selected the enclosure labels, which means enclosure connection is a common type of physical connection and it is relatively easy to distinguish. From the Oxford English Dictionary, enclosure is used to describe “the action of surrounding or marking off (land) with a fence or boundary”. Both the two enclosure connections are made up of different material, but that does not mean that enclosure is limited to two different materials. It is also seen in same material (see Figure 60). So it is easy to conclude that enclosure is a friendly word for them.



Fig 60 Detail of VASI bench (Lo, 2015)

4 “CSMA” Classification System Approaches

It is concluded from the research findings that four dominant types of classification method could define a physical connection relatively precisely which are: connection type, structure, material and appearance (see Figure 61). It is obvious to be distinguish the material type because people are familiar with it, so the researcher will not discuss this anymore. Separate discussions of the rest of the

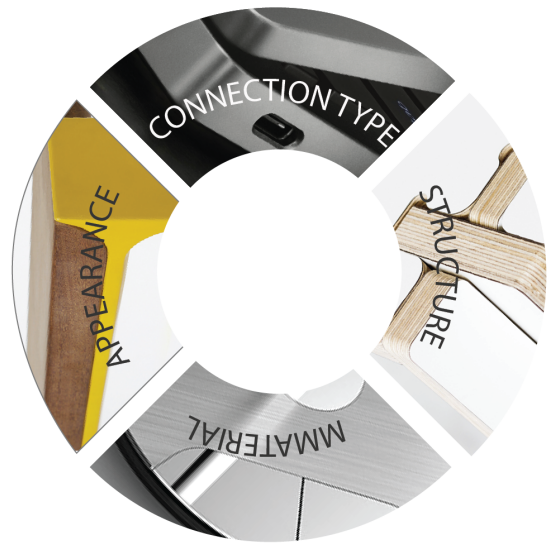

Fig 61 “CSMA”System

three classifications will be provided in the following paragraphs.

4.1 C-Connection Type

Connection type could be generally classified as static and dynamic, depending on if the physical connection is movable.

Static: Physical connections with non-removable features.

- **Hardware:** connections which are fastened or fixed with screws, nails or other mechanical parts
- Application: Cook handles; furniture
- Tips & Considerations: make the hardware are as more unnoticeable as well

- **Welding:** the connecting parts using the electric energy, chemical energy or mechanical energy to heat the edges of the metal until they begin to melt, and then pressing them together.
- Application: Metal-to-metal area; outdoor metal products; bicycle frame; metal furniture
- Tips & Considerations: different method of welding result in different appearance and visual effects
- **Joggle Joint:** a joint between two connecting parts by means of a projection on one piece that fits into a notch in the other.
- Application: most wood-to-wood connections, chair design,
- Tips & Considerations: The craftsmanship and structures of the joggle joints could be optimized for attractive appearance

Dynamic: Physical connections with removable features.

- **Hinge:** a mechanical bearing that connects two parts, typically allowing only a limited angle of rotation between them.
- Application: door design; foldable furniture
- Tips & Considerations: the material of hinges could be explored in different material (such as soft materials), not just limited to metal and wood
- **Rotational connection:** could be defined with 2D rotation and 3D rotation based on movement scale. The movement trail is defined with entire circular trace or part of circular trace.

- Application: movable part; lamp
- Tips & Considerations: could be emphasized as a focal point of a product
- **Slide:** A kind of movable connection that allows extension and compression in a linear structure. The movement trail could be a linear structure or a non-linear structure.
- Application: adjustable equipment; drawers
- Tips & Considerations: as simple as possible, consider the resistance of material
- **Buckle:** a fastening for two loose ends that is attached to one part and holds the other part by a catch
- Application: wood-to-fabric connections; leather watch; soft products such as backpacks
- Tips & Considerations: Good design implies the function closely to the user
- Hook: One curved or indented part holding other parts
- Application: Adjustable equipment; metal connection
- Tips & Considerations: Proportion is important to make the hook connection looks harmonious
- **Interlock:** By using the elasticity property of material or special shape to connect or lock (two or more parts) together.
- Applications: open and close products,
- Tips & Considerations: reduce the complexity of moulding

Below is the table that demonstrates connection type aspect of physical connections:

Factor	Category	Sub-category	Application
Connection Tye	static (fixed)	hardware	furniture;handle of cookers;
		joggle	wood to wood furniture
		welding	metal furniture; bicycle frame;
	dynamic (mov- able connection)	hinge: soft Hinge; metal hinge	laptop; door design; cases
		rotational	collapsible furniture
		2D rotational	
		3D rotational	
		slide	adjustable equipment; drawer
		hook	droplight; jewelry design;
		interlock	open and close products
buckle	leather watch; handbags and lu- aggages		

Table 9 Connection Type Classified of Physical Connection

4.2 S-Structure

Structure means the way the parts are connected. This factor demonstrates how the parts connect and are constructed. It is easily differentiated by designers.

- **Intersecting different pieces:** two parts intersect into one point or divide (something) in two by passing through or lying across it. It is differentiated with terminated intersection and through intersection.

- Application: wood-to-wood connections, pole to plate connections
- Tips & Considerations: better for knock-down furniture and modular furniture
- **Enclosure:** Parts are surrounded or marked off with a other part /other parts. There are two different kinds of enclosures: entire enclosure and semi enclosure. These two types of enclosures are differentiated by how deeply one part is enclosed.
- Applications: used in hard to soft materials
- Tips & Considerations: semi enclosure is commonly seen
- **Wrapping:** one part covers other parts by winding or folding a piece of material around it
- Applications: connecting fabric with other materials
- Tips & Considerations: be careful with the material selection t**Nested:** by using the gravity, one part shaped or manufactured fits into other parts
- Applications: glass table
- Tips & Considerations: the material of the holding part should be stable
- **Split:** One parts is broken apart or into pieces especially along a straight line
- Applications: foot of furniture, stand of equipments
- Tips & Considerations: only limited materials can achieve the split structure; a certain shape positively contributes to the appearance

Below is the table that demonstrates structure aspect of physical connections:

Factor	Category	Sub-category	Application
Structure	intersect different pieces	through intersect	Wood to wood connection; pole to plate connection
		terminated Intersect	connection between table top and leg;
	enclosure	entire enclosure	wood to leather
		Semi enclosure	
	wrapping		soft material to other material connection
	nested		glass table
split		foot of furniture	

Table 10 Structure Classified of Physical Connection

4.3 A- Appearance

Apart from connection type, material and structure, other factors that have impact on the physical connection design are categorized in the appearance aspect. The general



Fig 62 Simple Table” Connection (Knebel,2009)

appearance factors could be classified as form transition and material transitions. Sometimes two or more factors are mixed to contribute to the connection appearance. For example, one physical connection has both the contrast color and the form transition (see Figure 62) and designers

could pick both the contrast color and the form transition because both of them contribute to the appearance of this connection.

- **Smooth Form Transition:** the form transition of one part into the other parts are visually smooth and gentle
- Applications: legs of wood table, chair
- Tips: most time smooth form transition positively contributes to the connection appearance
- **Abrupt Form Transition:** the form transition of one part into the other parts are visually abrupt and relatively sharp
- Applications: some rotational connections
- Tips: sharp forms of the connection area could become a nightspot of a design
- **Color Transition:**the connecting parts use the similar color in the connection area.
- Applications: widely used
- Tips: could be emphasized as a design focal point
- **Contrast Color:** the connecting parts are made with two contrast colors.
- Applications: widely used
- Tips: contrast color can contribute to make the connection revealed,
- **Finish Transition:**the connecting parts are manufactured with two contrast finishing surfaces

- Applications: metal-to-metal connections
- Tips & Consideration: Finish transition can add visual interest and help user identify the

	Category	Sub-Category	Application
Appearance	form transition	abrupt form transition	rotational connections
		smooth form Transition	more fixed connections Welding connection
	material transition	color transition	widely used
		finish transition	metal-to-metal connections
		texture transition	soft material products
		color contrast	
		texture contrast	

Table 11 Appearance Classified of Physical Connection

Below are two examples (see Figure 63 & 64) showing the applications of the “CSMA” classified system.



Fig 63 Hinge of Lenovo yoga 3 pro laptop (Spears, 2014)

The Classification of Connection of “Lenovo yoga 3 pro laptop” Table	
Category	
Connection Type	Hinge
Structure	Terminated Intersecting different pieces
Material	Metal-to-metal Material
Appearance	Contrast Color

Table 12 The “CSMA” Classification of Hinge of lenovo yoga 3 pro laptop

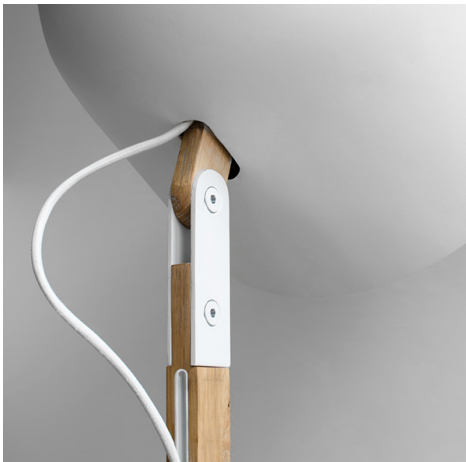

Fig 64 Connection of IGLOO Floor Lamp (Combe, 2014)

The Classification of Connection of IGLOO Floor Lamp	
Category	
Connection Type	2D rotation
Structure	Terminated Intersecting different pieces
Material	Wood-to-Metal Material
Appearance	Contrast Color

Table 13 The “CSMA” Classification of Connection of IGLOO Floor Lamp

5 DESIGN APPLICATION OF THE “CSMA” CLASSIFICATION SYSTEM

A website is designed to test the “CSMA” classification system and provide an inspirational gallery for designers to search for typical physical connections. The basic function of the website is to enable users to search the specific connection results by using the provided filter: connection type, structure, material and appearance. Website concepts are created based on the site analysis and sitemap. This website is also used to collect the data for quantitative research by recording users’ behavior.

There are following steps to create the website:

- Creating a simple site map.
- Building wireframes with templates showing page layout based on web standards.
- Prototyping in Just in Mind software and revising interface based on usability test

Adobe Illustrator and Just in mind will be used in the design process.

5.1 Function

The “Physical Connection Gallery” website will have three main functions. The first function is to introduce the “CSMA” system to users. The second function is to guide users to apply “CSMA” classification system to search their required physical connections. These matched examples will be displayed randomly, and users could explore more details about every physical connection. The last function of the website is to collect enough data to refine this classification system of physical connections by tracking the customers’ searching behavior and getting feedback from users.

5.2 Sitemap & Wireframe

According to functional requirements, a simple sitemap (see Figure 65) is created to show the structure of the website. Three functions will be achieved in three pages, which are: home-

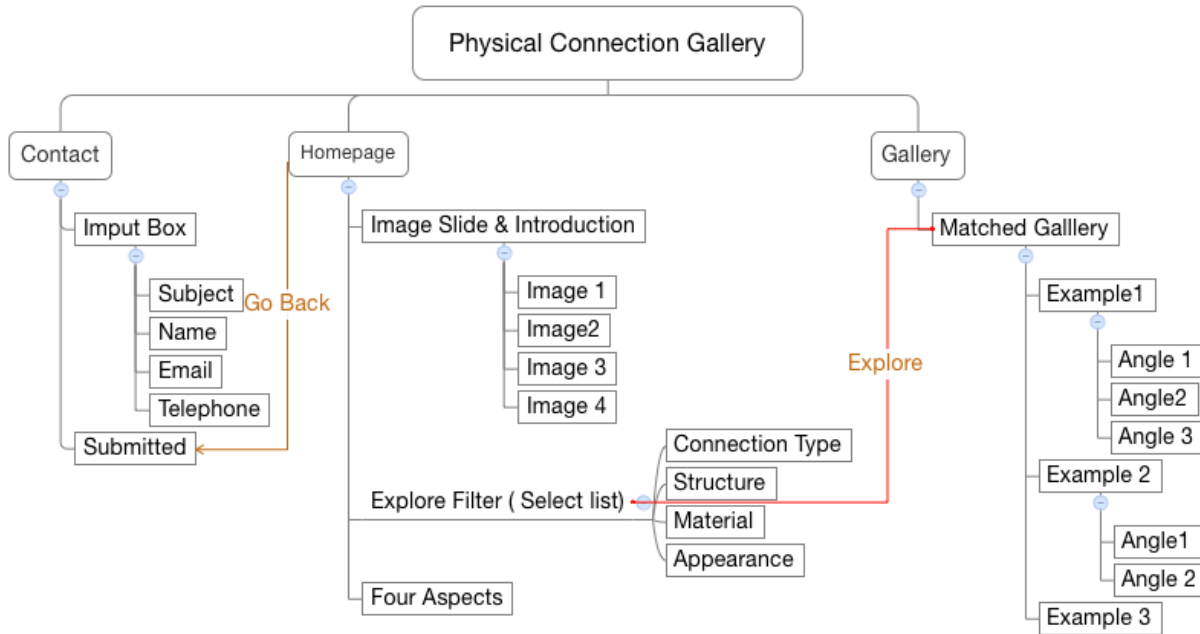

Fig 65 Initial Sitemap of Physical Connection Galley Website

page, gallery lists and contact page. Two original concepts are created. The big difference between these concepts are the layouts and the filters. The pinpoint area of the first concept (see Figure 66) is the middle page, where the filter result takes up too much space. The advantage of

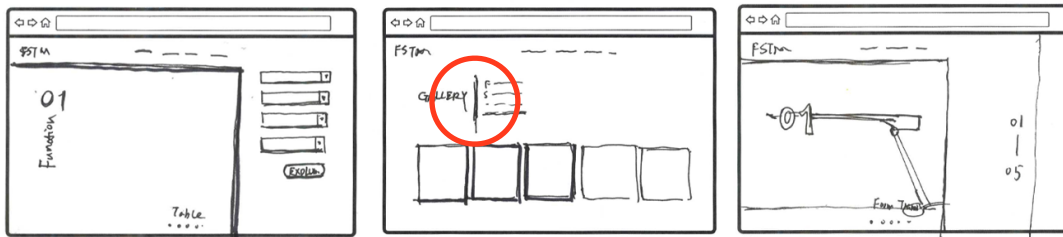

Figure 66 Concept 1 of the Physical Connection Gallery Website

the first concept is the third page. For the second concept (see Figure 67), there are pinpoint areas that need to be revised. The first area is the header page, the logo and background waste too much space. The second area is the list gallery of the selected connections, the scattered

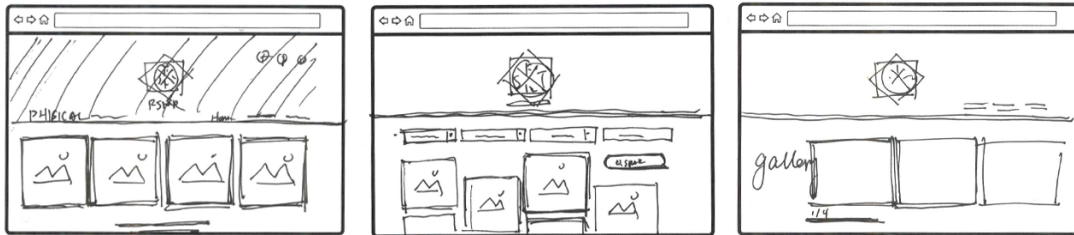

Figure 67 Concept 2 of the Physical Connection Gallery Website

arrangement of the images makes the navigation un-clear and difficult to navigate.

After collecting the feedback, the researcher would like to combine the introduction and filter at only one page and the matched gallery lists will be shown at another page. The selected category will also shown at the galley page and the next step is the matched connection examples. The researcher decided to repeat the filter (see Figure 68) at the gallery page because sometimes users will forget what they selected. This will provide the consistent searching behavior.



Figure 68 Filter of Gallery Page

The filter enables the user to select randomly. Also, the filter is flexible because the user could skip the some of the filter categories. For example, if a user only wants to find connections made with wood and soft material, he/she could overlook connection type, structure and appliance filters and just select the material filter (see Figure 69).

Figure 69 Filter of Material Selection

As the researcher mentioned in the abstract, another primary function for the website is to collect enough data and then develop quantitative research according to the data by tracking the customer searching behaviors. This could be achieved through the feedback submissions from the customers. At the beginning, the researcher considered implementing event tracking in javascript. Then the researcher found this caused inaccurate results because the event tracking will be influenced by many factors. So the researcher decided to use manual feedback to replace the event tracking to collect more precise information from users. A revised site map is created to show the new structure of the website (see Figure 70)

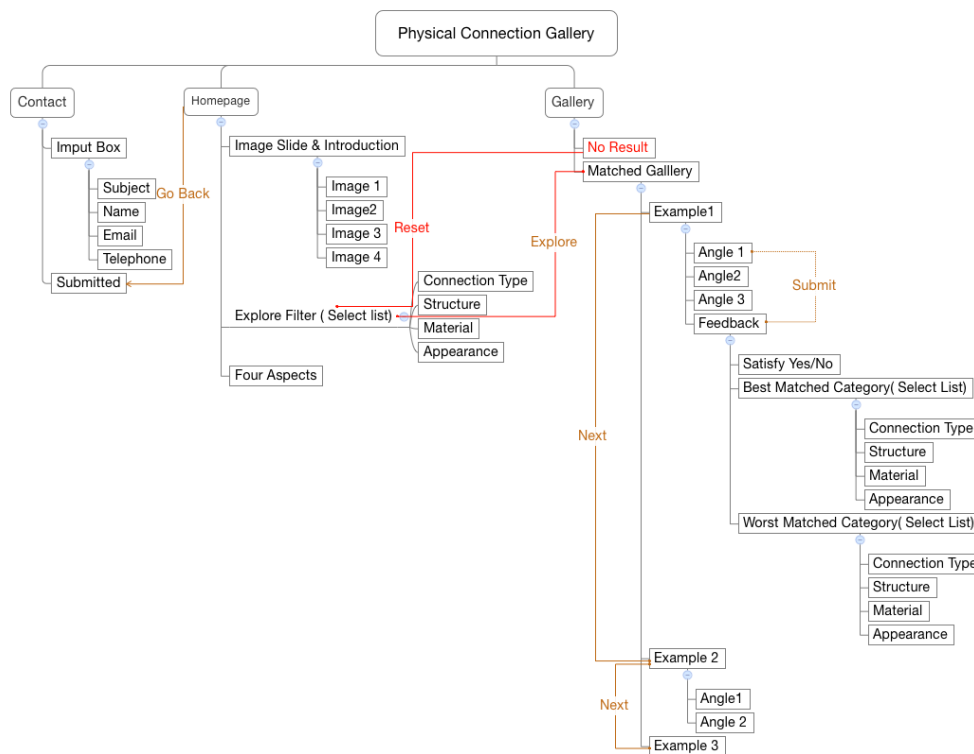

Fig 70 Revised Sitemap of Physical Connection Galley Website

As the revised sitemap illustrates, simple and optimized internal interactions were added to the website. For example, in the contact page, the user could just skip the home page by clicking on the “Go Back” button. Extreme conditions are also considered for the website. For example, there will be no combination result for connection

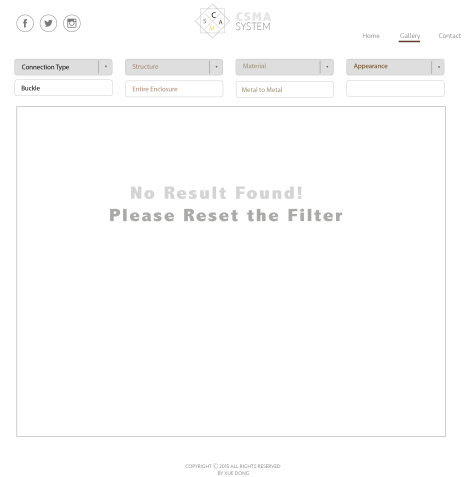

Figure 71 No Result Condition

type- “metal-to-metal”, “entire enclosure” and “ buckle”. The page will show “ No Result Found” (see Figure 71) and enables the user to reset the filters. A revised wireframe (see Figure 72) is created based on the previous discussion. At the homepage, the researcher introduced the

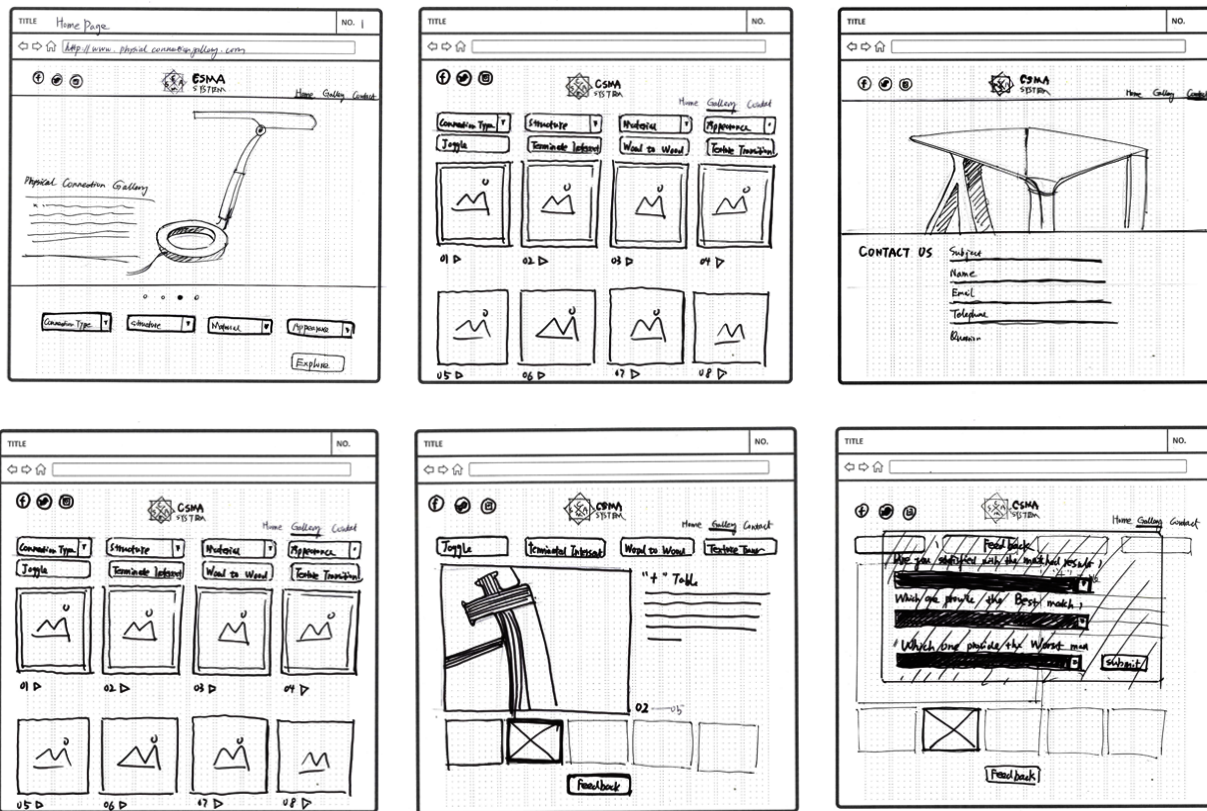

Figure 72 Revised Wireframe of the Physical Connection Gallery

four factors by explaining what they mean and mention some categories related to the four main factors. The user now could search different types of key categories in the filters. A user could choose just one filter type (for example — 2D rotate connection in the connection type filter, and the result will match all the 2D rotate connection images), or could select all the four types of categories (for example — 2D rotate, semi-enclosure, metal-to-metal, contrast color). The matched result of lists are showed at the gallery page. If interested, more details and perspective images will be provided for each physical connection. The user has the option to submit the feedback for each physical connection.

5.3 User Interface

Simple and clean style interface is displayed with grey color, in order to emphasize the physical connections. There are no extra colors and decorative elements. The color of the logo and text matches the main color of the wood, metal and other materials made with physical connections. Through the use of scrolling pictures on the homepage (see Figure 73), users are quick-

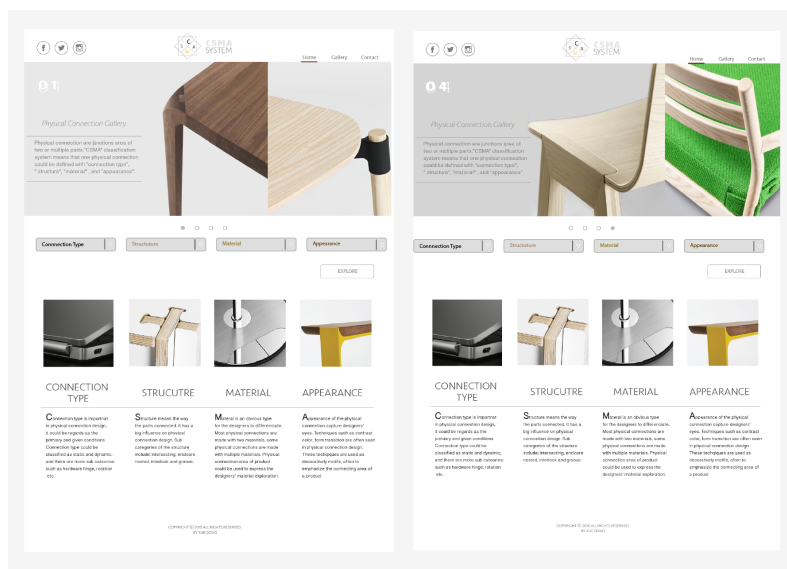

Figure 73 Homepage Layout

ly introduced to physical connections and the “CSMA” system. The matched physical connections are shown on the gallery page (see Figure 74). This layout is composed with filter results and the connection image list. The user could enter into each connection by clicking on the numbers. There are different angles for each physical connection and users also can submit their feedback at any time.

To sum up, the application of the “CSMA” classification system can provide useful inspirations for users. It is easy and convenient for users to find the required physical connections by using the “CSMA” filters. By recording the users’ feedback, the researcher could collect enough data of people’s opinions of physical connection classification and then develop quantitative research according to the data. More discussions about future potential research will be given in the next chapter.

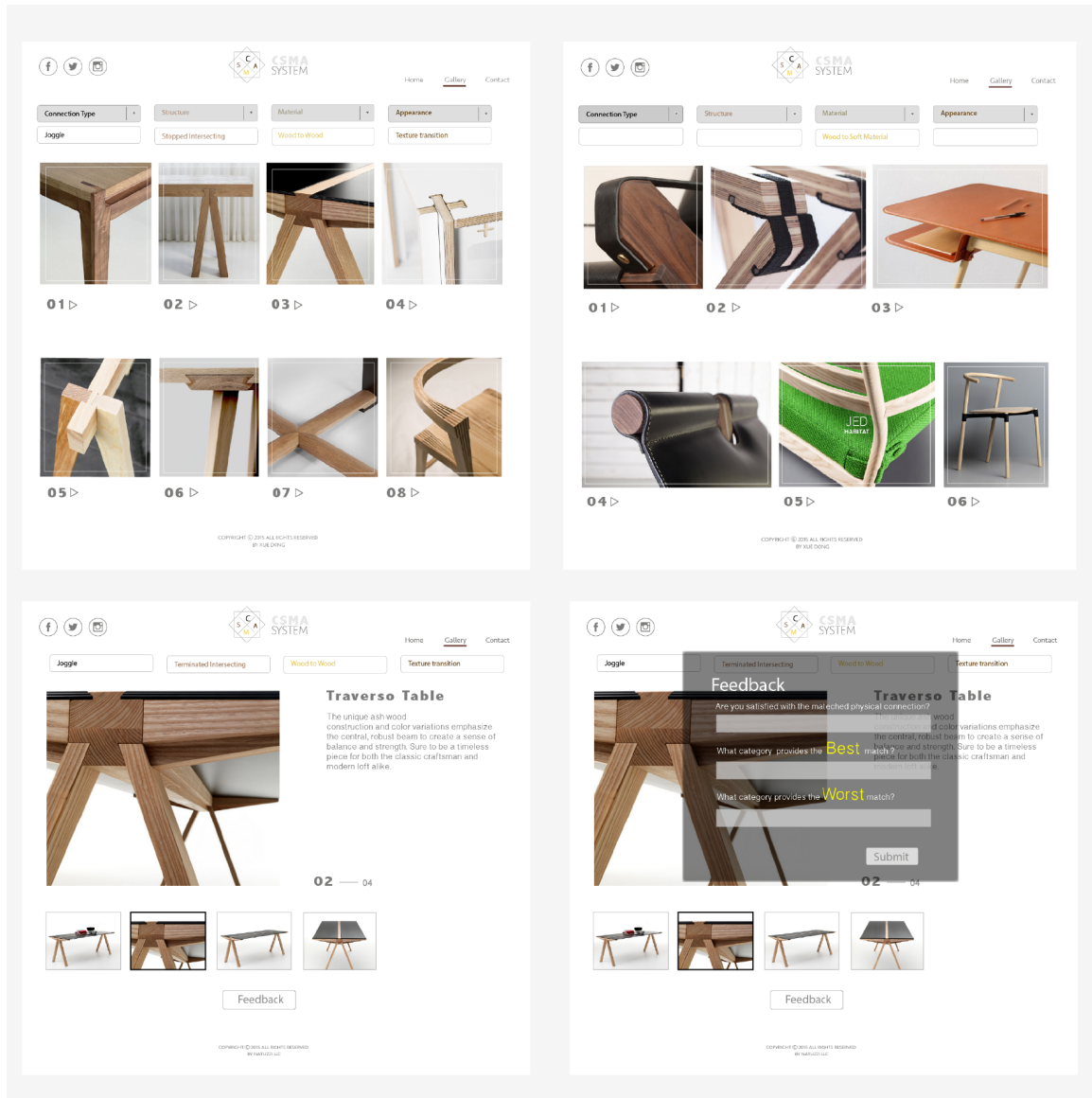

Figure 74 Gallery Page Layout

6 SUMMARY AND FUTURE EXTENSION

From the research outlined above, it seems there are several classification criteria to be applied even though their contributions to the aesthetic are at very difference levels. Designers consider the function and other aspects to guide them in creating a connection, but not by considering them one by one. From the observation of the survey, we might conclude that there exist visual priorities among the different connections, although the whole classification incorporates multi-dimensional information. At the beginning, the author would like to use the radar chart to describe the physical connections, but due to the limitations of resources and time, it is difficult to conduct quantitative research among the factors.

There are some dominant aspects in physical connections. As the researcher mentioned in the phenomena discussion, if more than one label was selected to describe the connection, material/color contrast is the dominant factor which captures people’s eyes first. Another example is form transition, which always plays a positive aspect contributing to the aesthetic of the connection. A multi-dimensional model is needed to describe which methods are able to make this balancing comprehensible. They represent different elements of connection and relate these elements, e.g. connection type, form, material and others. In the following discussion, the author would like to use termed elements to describe the model quickly.

Elements termed	Related words	Words in Suvey	
T-Connection type	Types of physical connection Physical Function	Rotational connection; Hardware Hinge welding	

Elements termed	Related words	Words in Suvey	
M - Material	Material selection texture color Finish	Contrast Material Material Transition Texture Transition	
S - Structure	Structure Combination way	Enclosure, Intersect different pieces, Interlock, nest, pierce,wrap	
R - Reveal	Hided Connection	Revealed Connection	
C - Conceal	Hided Connection	Concealed Connection	
FR - Form	Form,Shape	Smooth form Transition Abrupt form Transition	

Table 14 Terminology used for different elements

Generally, we know that there is a close relation between connection type and form in a physical connection (especially dynamic and relatively complex functions), which means most of the time the connection type has higher priority for physical connection design consideration. In Chapter One, the researcher also assumed that most of the time the connection type is the objective in given conditions, resulting fewer variations. Aesthetic considerations during a design project would be a complex system. Below is a rotational connection of a baby carriage (see Figure 75). According to the researcher's assumptions and survey analysis, rotational and hard function is the first to be considered. Also, the metal of the pole is the given condition because the strength requirement of the stroller. According to the material characteristics and other factors, the designer selects this kind of hard and smooth plastic to enclose the metal and, a round shape,

fitting the function and the metal material. Contrasting texture and color names reveal the connection area. The relationship of the factors are described in the following graphical model. In this model (see Figure 75), we could see that material factor is considered for twice. The first time (metal) is the given condition and it serves more for function, the second time (plastic) is selected together with structure and form.



Fig 75 Connection of Strollers for Stokke (Holmqvist, 2012)

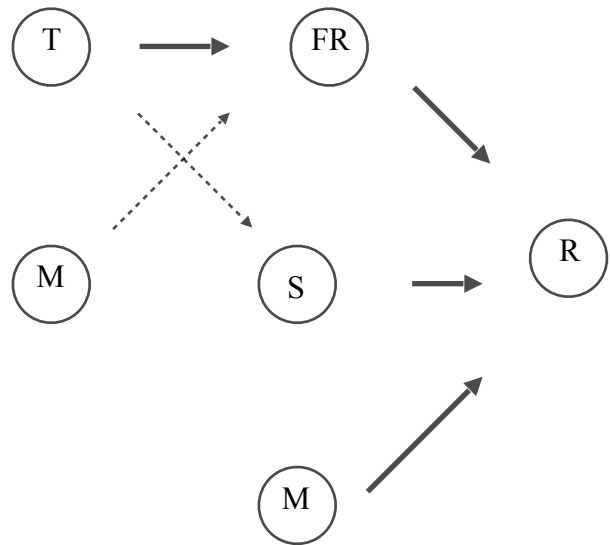

Fig 76 Graphical Model of Stroller Connection Consideration

Another example is from a wood-to-wood combination. The folding bench (see Figure 77) is made of plywood. When turned into this fabric hinge, most participants did not pay much attention to the connection type of that hinge. According to the researcher’s assumptions and survey analysis, connection type is the first and foremost factor to be considered for this hinge at the beginning. Material selection may be considered after the connection type, and based on the properties of the material, structure and form is created in order to meet the needs of the material. This relationship is described in the following graphical model (see Figure 78).



Fig 77 Connection of “63 Grad” Bench
(Barkschat &Blumel, 2012)

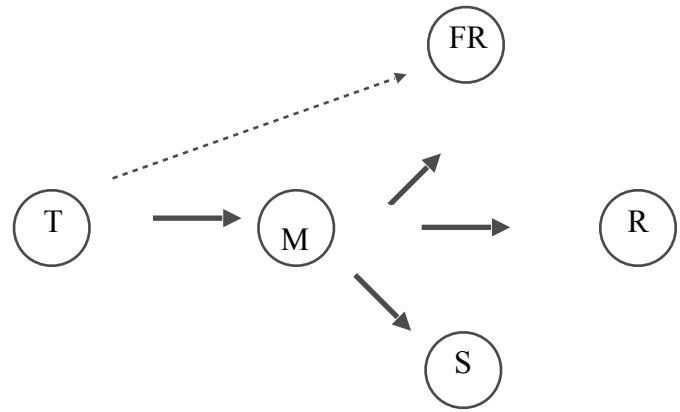

Fig 78 Graphical Model of
63 Grad” Bench Connection Consideration

These two examples could not include the relationships of all aspects. If more resources (such as a big data system) and time might be available in the future, the researcher would like to conduct a series of quantitative research studies via the website to explore the relationships between the physical connection labels uncovered in this study.

7 REFERENCE

Aarseth, S., Angell, C. (2012). Handle Me. Retrieved February 24, 2012, from

<http://nordicdesign.ca/handle-me/>

Ashby, M., Johnson, K. (2002) Materials and Design: the art and science of material selection in product design. Oxford Butterworth-Heinemann

Barber, A. (2012). Kik-stool. Retrieved August 20, 2012,

from <http://ths.gardenweb.com/discussions/2683001/kik-stool>

Barkschat, A., Blumel, F. (2012). Barkschat, Blumel and Arnold's 63 Grad Fold-Flat Bench.

Retrieved August 28, 2012. From [http://www.core77.com/posts/23276/Barkschat-](http://www.core77.com/posts/23276/Barkschat-Blumel-and-Arnolds-63-Grad-Fold-Flat-Bench)

[Blumel-and-Arnolds-63-Grad-Fold-Flat-Bench](http://www.core77.com/posts/23276/Barkschat-Blumel-and-Arnolds-63-Grad-Fold-Flat-Bench)

Beam, J.W. (1970). Retrieved from

https://www.1stdibs.com/furniture/tables/coffee-tables-cocktail-tables/vintage-coffee-table-designed-j-wade-beam-brueton-circa-1970/id-f_956958/

Béhar, Y. (2014). Furniture with street cred. Retrieved Feb.14, 2014

from <http://www.designindaba.com/articles/creative-work/furniture-street-cred>

Benjamin, Klebba. (2013). Phloem Studio. Retrieved August 21, 2013, from

<http://foliodigital.net/phloem-studio>

Berkowitz, M. (1987). Product Shape as a Design Innovation Strategy. *Journal of Product Innovation Management* 4:274–283.

Blackwell, A. H., Manar, E. (2015). “Prototype” UXL Encyclopedia of Science (3rd ed.).

Retrieved 13 July 2015

Boruslawski, P. (2015). Design and construct your own furniture with 3D printed joints

Retrieved Jan 29, 2015, from

<http://www.designboom.com/technology/olle-gellert-3d-printed-joints-07-29-2015/>

Bucci, A. (1998), *Quand les Idées Mènent l’Entreprise*. Paris: Dunod.

Buckle. (n.d.). In Merriam-Webster Online Dictionary. Retrieved October 28, 2009

From <http://www.merriam-webster.com/dictionary/buckle>

Budds, D. (2010). Roche Bobois Celebrates 50 Years. Retrieved Dec 6, 2010 from

<http://www.dwell.com/travel-reports/slideshow/roche-bobois-celebrates-50-years#2>

Butty. (n.d.). Retrieved from <http://handandeyestudio.co.uk/products/butty/>

BYAM. (2013). BYAM receives the French craftsmanship. Retrieved September 20, 2013

from <http://www.archiproducts.com/en/news/35443/byam-revives-the-french-craftsmanship.html>

Carballal, P. (2015). MAMET Lamps by Pablo Carballal. Retrieved April 14, 2015,

from <http://www.sohomod.com/blog/mamet-lamps-by-pablo-carballal/>

- Caula, R.(2014). Fuseproject designs flat-pack outdoor public furniture system for landscape forms. Retrieved January 31, 2014, from <http://www.designboom.com/design/fuseproject-multi-plicity-flat-pack-outdoor-public-furniture-for-landscape-forms-01-31-2014/>
- Chamfer. (n.d.). Retrieved from handandeyestudio.co.uk/products/chamfer/
- Chambers. J.,William.C., Beat.K., and Paul. T. (1983).
Graphical Methods for Data Analysis. Wadsworth. pp. 158-162
- Charinratana, J. (2013). OSS Collection.
Retrieved from <http://www.golf.studio248.com/golf/OOs.html>
- Colleuille, J.B. (2012). ANDROGYNE. Retrieved Sep, 2012
from <https://www.behance.net/gallery/Androgyne/6901447>
- Combe, E. (2014). IGLOO. Retrieved February 17, 2014
from <https://www.behance.net/gallery/14618925/IGLOO>
- Creusen, M.E., Schoormans, J.P. (2005).The different roles of product appearance in consumer choice *. *Journal of product innovation management*, 22(1)
- Crouch,S., Housden,M. (2003). Marketing research for managers; The Marketing Series;
Chartered Institute of Marketing. Butterworth-Heinemann. p. 22.
- Dawar, N., Parker, P. (1994). Marketing Universals: Consumers' Use of Brand Name, Price, Physical Appearance, and Retailer Reputation as Signals of Product Quality. *Journal of Marketing* 58:81–95.

- Derringer, J. (2015). Mamet lamps by Pablo Carballal. Retrieved March 24, 2015, from <http://design-milk.com/mamet-lamps-pablo-carballal/>
- Diez, S. (2013). The Milanese. Retrieved June 18, 2013, from <http://www.themilanese.com/?p=6981>
- Digerfeldt-Månsson, T., Venkatesh, A. (2005). Design As a State-of-Mind: The Aesthetics of Design and the Art of Marketing (p.24)
- Dudley, R. (1930). GUBI. From http://www.gubi.dk/en/products/lighting/floor-lamps/bestlite/bl3/bestlite-bl3s-floorlamp_001-03101/
- Eppinger, S., Browning, T. R. (2012). Design Structure Matrix Methods and Applications, Cambridge, Massachusetts: The MIT Press
- Etherington, R. (2012). Add system furniture by Werner Aisslinger for Flötotto. Retrieved February 14, 2013, from <http://www.dezeen.com/2013/02/14/>
- Faccin, F. (2012). TRAVERSO Table. Retrieved May 17, 2012, from <http://us.archello.com/en/product/traverso-table>
- Ganea, S. (2014). Modern Armchairs That Add Exuberance To Your Home. Retrieved June 26, 2014, from <http://www.homedit.com/modern-armchairs-that-add-exuberance/>
- Giessler, H. (2010). Tube. Retrieved from <http://www.hallo-essen.com/tube/>
- Hawks, L. (1987). Selecting Wood Furniture. Retrieved from extension.usu.edu
- Hekkert, P. (2006). Design aesthetics: principles of pleasure in design. Psychology Science, Volume 48, 2006 (2), p. 157 - 172

Hinge.(n.d.). Merriam-Webster Online Dictionary.

Retrieved <http://www.merriam-webster.com/dictionary/hinge>

Holmqvist, J.(2012). Permafrost Designs Two New Strollers for Stokke.

Retrieved December 13, 2012, from <http://www.dexigner.com/news/26034>

Hook.(n.d.). Merriam-Webster Online Dictionary.

Retrieved <http://www.merriam-webster.com/dictionary/hook>

Hunt, H. (2016). Madeline Table. Retrieved from

<https://www.hollyhunt.com/ShowProduct.aspx?ProductID=7335&ManufacturerID=1>

Irvin, D. (2013). Corner Table. Retrieved from <http://www.davidirwin.co/?cat=1>

Jedrejic, Z., Ugresic, A. (2014). Armada & Layair Armchairs from Hooklund Stool.

Retrieved April 25, 2014, from <http://design-milk.com/armada-armchair-layair-collection-hooklundstool/>

Joggle Joint. (n.d.). In Collins Online English Dictionary.

Retrieved from <http://www.collinsdictionary.com/dictionary/english/joggle>

Jordan, M. I. (1997). An Introduction to Graphical Models. Retrieved from

<http://www.ai.mi.tedu/projects/jordan.html>

Joy Tables Family by Arco. (2014). Retrieved September 4, 2014, *from*

<http://design-chronicle.com/joy-tables-family-by-arco/>

Kaufman,E. J.(1990). What is modern design. The Museum of Modern Art-New York

Kaye, D. (2013). The Secret to Successful Product Design? Simplicity. Retrieved May 29, 2013

from <https://www.entrepreneur.com/article/226834>

Keane-Cowell, C. (n. d.). Fancy a Joint?: Innovative joinery in new furniture design.

Retrieved from <http://www.architonic.com/ntsht/fancy-a-joint-innovative-joinery-in-new-furniture-design/7000508#top>

Klebba, B. (2013). Retrieved May 14, 2013, from <http://blog.phloemstudio.com/?p=854>

Knebel, K.(2009). Simple table. Retrieved from

<https://www.behance.net/gallery/simple-table/309612>

Lazure-Guinard, K.(2012). Handle me. Retrieved February 24, 2012,

from <http://nordicdesign.ca/handle-me/>

Lee, S.(n.d.). Finger Joint - Chair. Retrieved from

<http://www.lee3woong.com/works-finger%20joint-chair-closeup.htm>

Lindberg. (1996). Retrieved from <http://www.eyescafe.co.kr/web/product/lindberg/rimcase.JPG>

Lo, Chi Wing. (2014). Learn more about VASI bench Retrieved from

<http://www.chiwinglo.it/en/collection/sofas-and-armchairs/vasi-bench>

Mankiewicz, A.(2014). Retrieved from <https://www.pinterest.com/alaynamackiewicz/>

Martindale, C. (1990). The clockwork muse: The predictability of artistic change.

New York: Basic Books.

Mckenzie, T. (n.d.). Floating white washed white oak hall table. Retrieved from

<http://www.tylermckenzie.ca/white-washed-oak-hall-table>

McQuarrie, M. (2015). 15 Creative Furniture Joinery Pieces; Retrieved from

<http://www.trendhunter.com/slideshow/furniture-joinery>

MDF. (2014). Design-technology.org. Retrieved April 2, 2014

from <http://www.design-technology.org/mdf.htm>

Mogensen, B. (n.d.). Børge Mogensen Hunting Chair. Retrieved from

<http://www.danishdesignstore.com/products/borge-mogensen-hunting-chair>

Mok, K. (2015). Versatile, downloadable 3D printed joints for customized DIY furniture.

Retrieved August 20, 2015, from <http://www.treehugger.com/eco-friendly-furniture/print-to-build-downloadable-3d-printed-furniture-joints-olle-gellert.html>

Mortise. (n.d.). Mortise And Tenon Frame Joints. Retrieved from

<http://www.redsandalwood.com/en/?knowledge/pid/502/tp/561>

Ness, A. (2013). Horizon Table. Retrieved Dec 21, 2013

from <http://andrewness.com.au/post/71673654024/handmade-coffeetable>

Noe, R. (2012). Barkschat, Blumel and Arnold's 63 Grad Fold-Flat Bench.

Retrieved August 28, 2012, from <http://www.core77.com/posts/23276/>

Nora. (2009). Nora Table. Retrieved from <http://stokkeastad.com/project/nora-table>

Peltier, Jon (2008-08-14). "Rock Around The Clock - Peltier Tech Blog". Peltiertech.com.

Retrieved 2013-09-11.

Plywood. (2000). Ply_Wood. Retrieved from

http://www.thorstenfranck.com/productdesign/tf/Eintrage/2000/6/30_PLY_WOOD.html

Pruned, D. (2014). 3D-printed 'keystones' open the door to cheap, sturdy DIY furniture.

Retrieved May 1, 2014, from <http://www.digitaltrends.com/home/keystone-connectors-make-furniture-with-a-single-3d-printed-piece/>

Putzier, M. (2012). Noctus. Retrieved October, 2012,

from <http://moritzputzier.com/work/83-noctus>

Rouse, M. (2005). Site Map. Retrieved Sep, 2005

from <http://searchsoa.techtarget.com/definition/site-map>

Sleek. (n.d.). Retrieved from <http://haute-living.com/dining/tables/2402/sleek-table/6854-sleek-4>

Sling Chair. (n.d.). Merriam-Webster Online Dictionary.

from <http://www.merriam-webster.com/dictionary/sling%20chair>

Slip Connection. (n.d.). Merriam-Webster Online Dictionary.

from <http://www.merriam-webster.com/dictionary/sling%20chair>

Squee, Gee. (2008). Paint Or Die But Love Me. Retrieved July 23, 2008, from

<http://www.core77.com/posts/10600/paint-or-die-but-love-me-10600>

Spears, T.(2014). Lenovo yoga 3 pro laptop's flexible-use stabilized by watchband hinge.

Retrieved Oct.10,2014 from

<http://www.designboom.com/technology/lenovo-yoga-3-pro-laptop-10-10-2014/>

Stithis, P. (2012). Trapeze Large LED Table Lamp. Retrieved from

<http://www.yliving.com/light-and-contrast-trapeze-large-led-table-lamp.html>

Stenberg, M. (n.d.). Carry On. From <http://www.offecct.se/en/products/accessories/carry-on>

Stellar. <http://www.stellarworks.com/japan/collectview.php?cid=68>

Sunny, C.,Matthew,H. (2003). Marketing Research for Managers. Butterworth-Heinemann.

Ulrich, K. T. (2006). Design Creation of Artifacts in Society. Page:11-16

VanKesteren, I.E.H. (2005). Representing product personality in relation to materials in a

product design problem. Proceedings of the international conference of the Nordic

Design Research society, Kopenhagen 2005

Vailly, T. (2013). Table Production Unit. Retrieved from

<http://www.vailly.com/projects/low-table-production-unit/>

Very concise folding desk lamp.(2012). Retrieved November 7, 2012,from

<http://imwm.org/very-concise-folding-desk-lamp/>

Vifa. (n.d.). Helsinki — Petite, Powerful Bluetooth Loudspeaker with Incredible Sound.

From <http://www.vifa.dk>

Webber, Tim. (n.d.). Duffel Stool Retrieved from

<http://www.timwebberdesign.com/duffel-stool/>

Williamson, C. (2013). Minimal Waste + Table by Fraaiheid. Retrieved March 21, 2013

from [http://design-milk.com/plus-table-by-fraaiheid/?utm_source=feedburner&utm_campaign=Feed:+design-milk+\(Design+Milk\)](http://design-milk.com/plus-table-by-fraaiheid/?utm_source=feedburner&utm_campaign=Feed:+design-milk+(Design+Milk))

Yi, Chen. (2012). John Nouanesing thinks outside the box for furniture design.

Retrieved June 1, 2012, from <http://www.psfk.com/2012/06/spilled-paint-table.html>

Young, M. (2013). Joint-Accentuating Furniture. Retrieved from

<http://www.trendhunter.com/trends/patch-by-beza-projekt>

Yeongkyu, Yoo (n.d.). Bottle Humidifier by Yeongkyu Yoo. Retrieved December 11, 2014

from <http://design-milk.com/bottle-humidifier-yeongkyu-yoo/>