

**A New Concept Design of Directional Rumble Strips
for Deterring Wrong-way Freeway Entries**

by

Lingling Yang

A thesis submitted to the Graduate Faculty of
Auburn University
in partial fulfillment of the
requirements for the Degree of
Master of Science

Auburn, Alabama
May 7, 2016

Keywords: Highway Safety, Wrong-way Driving, Transverse Rumble Strips (TRS), Directional Rumble Strips (DRS), Speed Effects, Sound and Vibration

Copyright 2016 by Lingling Yang

Approved by

Huaguo Zhou, Chair, Associate Professor of Civil Engineering
Rod Turochy, Associate Professor of Civil Engineering
David Timm, Professor of Civil Engineering

ABSTRACT

Wrong-way driving (WWD) on freeways has been identified as a serious traffic safety problem. Drivers who make wrong-way entries onto freeways pose a serious risk to the safety of other motorists and themselves. This study investigates the feasibility of a novel design of Directional Rumble Strips (DRS) to discourage wrong-way entries onto freeway exit ramps. In order to obtain the most optimal design of DRS, the study first evaluated the effectiveness of existing Transverse Rumble Strips (TRS) applications and set the driver's perceptibility threshold of sound and vibration based on the field data. Particular attention was given to the TRS treatments on the approaches to the high speed intersections with typical installations in Alabama. The measurement of effectiveness was selected as attention-getting characteristics, speed changes, and driver braking behavior. The test results showed that implemented TRS can generate sound and vibration that have significant effects on vehicle speed and driver performance during both day and nighttime conditions. For sound levels at different speeds, the A-weighted volume in the area of the TRS was on average 14 dBA above the baseline noise level without TRS, and the vibration signal along the vertical axis resulted in an average difference of 0.68 m/s^2 when compared with normal pavement. The average speed reductions ranged between 0.95 to 8.63 mph for time mean speed, and from 0.84 to 9.71 mph for the 85th percentile speed. The percentage of braking behavior accounted for 40% to 80% of recorded vehicles. All these findings support the possibility of using DRS to influence the wrong-way driver's behavior and also provide references for the DRS design and effectiveness evaluations.

Several conceptual designs of DRS were proposed based on the state DOT design guidelines, current practices, and feedback from a national survey. Each of the concept designs was expected to generate elevated noise and vibration for wrong-way driving, and normal noise and vibration for right-way traffic on exit ramps. A national survey collected the opinions on the conceptual designs from transportation practitioners and vendors who are knowledgeable about rumble strips design, manufacturing, or installation. Based on the survey and literature review results, a total of five patterns and eight configurations were developed for evaluation. The field tests were conducted to collect noise and vibrations generated by the proposed eight DRS configurations at the pavement test track of the National Center for Asphalt Technology (NCAT) of Auburn University. Six speed categories for the testing vehicles were set at 10 mph, 15 mph, 20 mph, 25 mph, 35 mph, and 45 mph. At least six field measurements were taken for each speed category in both directions. The generated sounds and vibrations for the WWD were compared with the ambient conditions and existing TRS stimuli levels. The results suggest that all the tested patterns generated adequate sound changes in the wrong-way direction to alert drivers to slow down (7.2 to 16.6 dBA increases). Pattern D Configuration 3 and Pattern E produced comparable vibration changes with previous studies (2.57 m/s^2 and 2.30 m/s^2 , respectively). Statistical analyses were then conducted to examine if there was a significant difference in the sound and vibration between right and wrong directions. Pattern C generated significantly different sound and vibration signals when driving in the wrong-way direction and the right-way direction from 10 to 25 mph. The Pattern E generated significantly different vibration at speed of 45 mph. Finally, DRS Pattern C, Pattern D Configuration 3, and Pattern E were recommended for further optimization and implementation based on their attention-grabbing effects.

ACKNOWLEDGMENTS

Firstly, I would like to express my sincere gratitude to my advisor Dr. Zhou for his continuous support of my study and related research, and for his patience, motivation, and immense knowledge. His guidance helped me in throughout the time of research and writing of this thesis. He is also the mentor of my life. Without his enduring support and great help it would not be possible for me to progress both academically and in my personal endeavors.

Besides my advisor, I am also immensely grateful to the rest of my thesis committee: Dr. Turochy and Dr. Timm, for their insightful comments and encouragement. I registered in the courses of “Traffic Engineering Analysis” of Dr. Turochy and “Pavement Design and Constructions” of Dr. Timm. Both of these courses widened my study and research from various perspectives. Dr. Turochy and Dr. Timm always provided me with great help and invaluable support.

My sincere thanks also goes to Dr. Linxi Zhu, and my fellow labmates: Raghu Baireddy, Mohammad Jalayer, Dan Xu, Beijia Zhang, Hongyang Qu, Bojun Dan, for the days we worked together, and for all the fun we have had in the working times. I am also grateful to Mahdi Pour Rouholamin, Fatemeh Baratian Ghorghi, and Jin Wang. Their endless pursuit of excellence always encouraged me to work harder.

Finally, I must express my very profound gratitude to my family for providing me with unflinching support and continuous encouragement throughout my years of study. This accomplishment would not have been possible without them.

The research described here was in support of the research project “Directional Rumble Strips for Reducing Wrong-Way Driving Freeway Entries” funded by the University Transportation Center (UTC) Region 5 through the University of Minnesota.

TABLE OF CONTENTS

Abstract.....	ii
Acknowledgments.....	iv
List of Figures.....	viii
List of Tables	x
List of Abbreviations	xii
Chapter 1 Introduction	1
1.1 Wrong-way Driving Issues	1
1.2 Transverse Rumble Strips (TRS)	2
1.3 Objective of the Study	3
1.4 Outline of the Chapters	4
Chapter 2 Literature Review.....	5
2.1 TRS Design Guidelines	5
2.2 TRS Effectiveness Evaluation	8
Chapter 3 Methodology	11
3.1 Initial Field Test of TRS Effects	11
3.1.1 TRS Site Description.....	11
3.1.2 Interior Noise Level and Vibration Testing	13
3.1.3 Vehicle Speed and Driver Behavior Measurement	15
3.2 National Survey	16
3.3 DRS Field Test	17
3.3.1 Test Locations	17

3.3.2 Test Schemes.....	18
3.3.3 DRS Installations.....	19
Chapter 4 Analysis and Results	21
4.1 Initial Field Test Results	21
4.1.1 Sound and Vibration Effects	21
4.1.2 Effects on Vehicle Speed	25
4.1.3 Driver Behavior.....	29
4.2 Conceptual Designs of DRS	30
4.3 Survey Results	33
4.4 DRS Field Test Results.....	36
4.4.1 Results for Configuration Tests.....	37
4.4.2 Comprehensive Comparisons of DRS Configurations.....	51
4.4.3 Factors affecting DRS sound and vibration effects.....	58
Chapter 5 Conclusions	62
References.....	65
Appendix A	69
Appendix B	74

LIST OF FIGURES

Figure 1	7
Figure 2	7
Figure 3	13
Figure 4	14
Figure 5	14
Figure 6	18
Figure 7	20
Figure 8	20
Figure 9	22
Figure 10	23
Figure 11	27
Figure 12	28
Figure 13	28
Figure 14	32
Figure 15	33
Figure 16	33
Figure 17	37
Figure 18	39
Figure 19	40

Figure 20	41
Figure 21	42
Figure 22	43
Figure 23	44
Figure 24	45
Figure 25	46
Figure 26	47
Figure 27	48
Figure 28	49
Figure 29	50
Figure 30	52
Figure 31	54
Figure 32	59
Figure 33	61

LIST OF TABLES

Table 1	6
Table 2	12
Table 3	19
Table 4	24
Table 5	26
Table 6	29
Table 7	31
Table 8	31
Table 9	34
Table 10	35
Table 11	36
Table 12	38
Table 13	39
Table 14	41
Table 15	43
Table 16	44
Table 17	46
Table 18	48
Table 19	50

Table 20	53
Table 21	53
Table 22	55
Table 23	56
Table 24	57
Table 25	60
Table 26	61

LIST OF ABBREVIATIONS

WWD	Wrong-way Driving
TRS	Transverse Rumble Strips
DRS	Directional Rumble Strips
MOE	Measure of Effectiveness
ANOVA	Analysis of Variance
DOT	Department of Transportation
FHWA	The Federal Highway Administration
NCAT	National Center for Asphalt Technology
AU-ESCTF	Auburn University Erosion and Sediment Control Testing Facility

CHAPTER 1

INTRODUCTION

1.1 WRONG-WAY DRIVING ISSUES

Drivers who make wrong-way entries onto freeways pose a serious risk to the safety of other motorists and themselves. The National Transportation Safety Board (NTSB) reported that the primary origin of wrong-way movement occurs when a driver enters from an exit ramp (NTSB 2012). Wrong-way crashes are relatively infrequent but are more likely to produce serious injuries and fatalities compared to other types of crashes. A recent study of the Fatality Analysis Reporting System (FARS) showed that Wrong-way Driving (WWD) caused between 300 and 400 annual traffic fatalities from 2004 to 2011 in the United States (Zhou et al. 2012). This number of fatalities has been consistent even though total traffic fatalities declined by 4% over the 8-year period from 2004 through 2011.

As early as the 1970s, the WWD freeway entries had raised the attention of transportation agencies. Virginia Department of Transportation (DOT) performed some on-site investigations in Virginia and proposed countermeasures in terms of geometric design, pavement marking, and roadway signage (Vaswani 1974, NCHRP 1976). California DOT (1978) developed the counter and surveillance system for off-ramps, and recommended placing the DO NOT ENTER wrong-way signs and the wrong-way pavement lights (a row of red lights embedded in the pavement across the off-ramp). In most recent practices, many agencies committed to upgrade signage along freeways, such as larger versions of DO NOT ENTER and WRONG WAY signs (Arizona DOT 2014), lower mounting height (Ohio DOT 2012), and solar powered flashing signs

(Washington State DOT 2011, Florida DOT 2014, Rhode Island 2015, Missouri DOT 2014).

Some high-technology countermeasures were also emerging to reverse the troubling trend of wrong-way freeway entries. The Intelligent Transportation System (ITS) was employed to detect wrong-way drivers immediately upon entry, notify the traffic management center and public safety dispatch of the wrong-way entry point, and inform the errant driver of their potentially fatal mistake via visual and/or audible warnings to prompt drivers into corrective action (New York DOT 2013, Sarah and Reza 2015).

Despite decades of improvements on design, marking, and signage at freeway interchanges, more efforts should still be taken to mitigate the WWD issue. The latest study by the NTSB (2012) also concluded that there is a need “to establish—through traffic control devices and improved highway designs—distinctly different views for motorists approaching entrance and exit ramps.”

1.2 TRANSVERSE RUMBLE STRIPS (TRS)

The TRS is a type of warning system that provides motorists with audible, visual, and tactile signals when approaching a decision point. Some countries around the world have used TRS as a safety feature. Austria applied the TRS at the entrance to tunnels. France has some “noisy transverse strips” to alert drowsy drivers (CEDR 2010). In China, the TRS is installed in southern areas to help reduce vehicle speeds at critical locations on rural roads, such as the crosswalks (Liu et al. 2011). The Transportation Association of Canada published “Best Practice Guidelines for the Design and Application of Transverse Rumble Strips” (Bahar et al. 2005), which provides an overall summary of extensive research and practices.

In the United States, TRS are mainly installed on approaches to intersections, toll plazas, horizontal curves, and work zones (FHWA 2014). According to a Minnesota Department of

Transportation (DOT) synthesis (Corkle et al. 2001), 56 of the 68 Minnesota counties responding to a rumble strip survey use TRS. Most of these counties (48 of the 56) use two sets of rumble strips prior to the intersection or change in traffic control. Texas DOT states that TRS should only be used at high incident and special geometric locations (Texas DOT 2006). Besides the regular TRS locations, Maryland DOT also suggests that TRS may be useful to address the need for a reduced speed zone with a posted speed reduction of 20 mph or greater or an entrance to a town, business district, or location where significant pedestrian activity is anticipated. Also, the TRS may be used in work zones in advance of detours, flaggers, lane transitions, lane closures, temporary traffic signals, and locations with major reductions in speed limits (SHA 2011).

1.3 OBJECTIVE OF THE STUDY

The current study explores the feasibility of introducing the Directional Rumble Strips (DRS), a novel design of TRS, on the freeway exit ramps to add safety features for reducing WWD. The DRS is designed to generate elevated noises and vibrations to warn against WWD and to generate normal noises and vibrations to slow down the traffic for the right-way direction. Many advanced technologies that have been used to detect WWD at exit ramps require quick responses by traffic monitoring centers (TMCs) and law enforcement to effectively stop WWD. This new traffic control device is more suitable for rural areas where modern TMCs and quick response are not available.

The objectives of this study are: (1) to evaluate the effectiveness of the TRS currently applied on US highways on the driver perceptions and responses; (2) to propose different conceptual designs of DRS based on existing TRS design guidelines and practices; (3) to collect the comments for DRS designs through a national survey and measure the effectiveness of

different patterns by field tests; (4) to identify the crucial factors for DRS designs based on field test results and pave the way for the final optimal design.

1.4 OUTLINE OF CHAPTERS

The rest of the thesis proceeds as follows: Chapter Two provides a comprehensive summary of TRS configurations and layout based on State DOT design guidelines. It also summarizes the TRS effectiveness and evaluation methods in previous studies. Chapter Three contains a broad explanation of the methodology used in this study: the selection of proper locations for initial TRS field tests, the initiation of the national survey, and the field evaluation method for the developed DRS. Chapter Four discusses the results of initial field test of TRS, feedbacks from the national survey, and detailed analysis of DRS sound and vibration effects. Chapter Five concludes the thesis with findings under the current stage and recommendations for future studies.

CHAPTER 2

LITERATURE REVIEW

This chapter summarizes the design guidelines of TRS installation in different states. The comprehensive review provides references to determine crucial DRS design parameters, including the shape, layout, and detailed dimension. To identify the appropriate measure for the DRS effectiveness evaluation, this chapter investigates the measure of effectiveness for rumble strips based on previous studies.

2.1 TRS DESIGN GUIDELINES

Highway agencies and DOTs usually release their design guidelines for different rumble strips and update them as circumstances change. The 1993 synthesis provided typical values for TRS summarized from the design practices of 24 state highway agencies (Harwood 1993). The result shows that the TRS design practices vary widely.

In Minnesota, an approach to a stop-controlled intersection can have up to five sets of TRS, but a minimum of three sets are recommended. The length of each TRS panel is about 5 feet (MnDOT 1999). Jefferson County, Montana, installed the TRS in a stop-controlled T-intersection. A total of four sets of TRS were installed. The TRS have an 11.8 inch offset from the travel lane edge, a 3.9 inch width, a 0.6 inch thickness, and 7.9 inch spacing (MDT 2004). In Iowa, until 2006, three sets of TRS were required (Iowa DOT 2006). This standard was altered in April 2006 and again in May 2007 to require only two sets of TRS, removing the TRS closest to the intersection. Currently, each TRS panel is 24 feet long and consists of 25 grooves placed at 1-foot intervals perpendicular to the centerline (USDOT/FHWA 2012). Michigan DOT required

occasional usage of trunklines TRS. The rectangle cross section is 4 inches wide and 0.5 inches deep, the grooves are separated by an 8-inch spacing (MDOT 2011). In Maryland, milled TRS are applied to the surface of the pavement with pavement marking material, and they are created by stacking two pieces of formed pavement marking material to obtain the desired thickness (SHA 2011). Table 1 details the configurations of TRS in several states.

Table 1 TRS configurations of several states

State	Raised or Grooved	Strips in each set	Length (ft)	Width (in)	Spacing (in)	Thickness (in)	Offset (in)	Ref.
Minnesota	Grooved	6	3.3×2	5.9 ±0.2	11.8-5.9 =5.9	0.4±0.1	7.9 from centerline 19.7 from shoulder	MnDOT 1999
Michigan	Grooved	25	-	4	8	0.5	12	MDOT 2011
Maryland	Raised	10	-	-	54 or 72	5+5 10+5	-	SHA 2011
Montana	Grooved	16	12	4	8	5/8=0.625	12	MDT 2004
Oregon	Grooved	11	10	5(1/2)	18-5.5 =12.5	1/2	12×(Lane Width-10 ft)/2	Oregon DOT 2013
Arizona	Grooved	6	Lane width/COS (15degree)	4	12	3/8=0.375	0	ADOT 2014
Texas	Raised	5	4×2	-	24	-	6-12	TxDOT 2006
New Hampshire	Grooved	Min 11	-	-	-	-	3/8	State of New Hampshire, 2013

Texas DOT issued design guidelines for both standard and alternative patterns. The alternative TRS only run the width of a vehicle's wheel path to reduce driver's swerving maneuvers (TxDOT 2006). The dimensions of the TRS are shown in Figure 1.

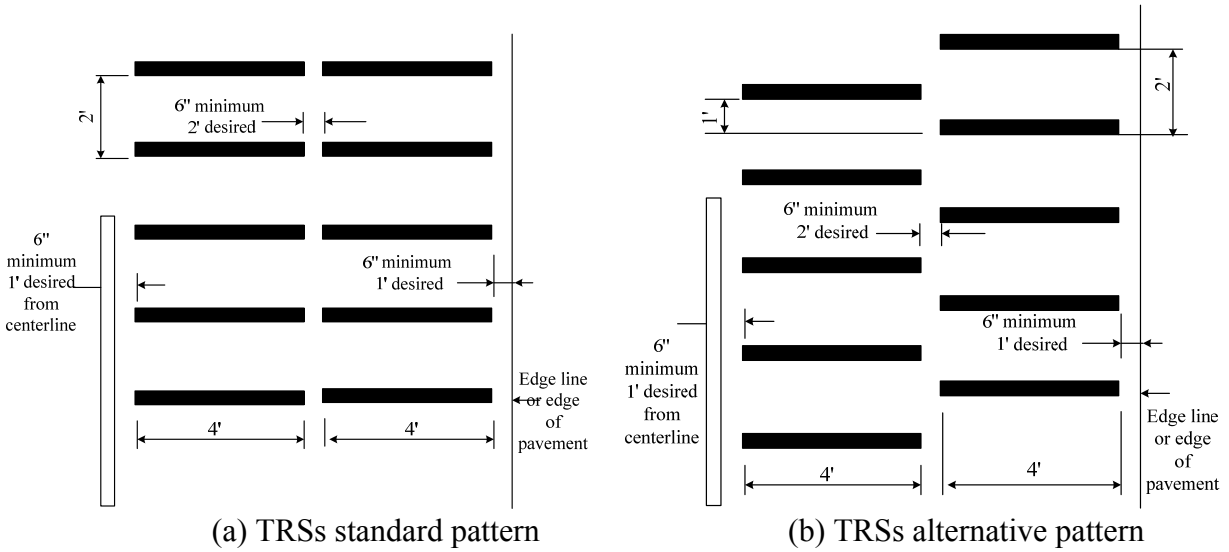

Figure 1 Texas DOT TRS designs (TxDOT 2006)

According to Arizona DOT 2014 revisions to its TRS details (ADOT 2014), the TRS are installed in three sets before the decision point, the gap among the sets range from 125 to 200 feet, corresponding to the approach speed of 35 to 55 mph. The guideline provides two different set designs for snow and non-snow zones as shown in Figure 2. The non-snow zone TRS are made by raised pavement makers, and the snow zone TRS are cut-grooved and measure 15 degrees with the lateral axis.

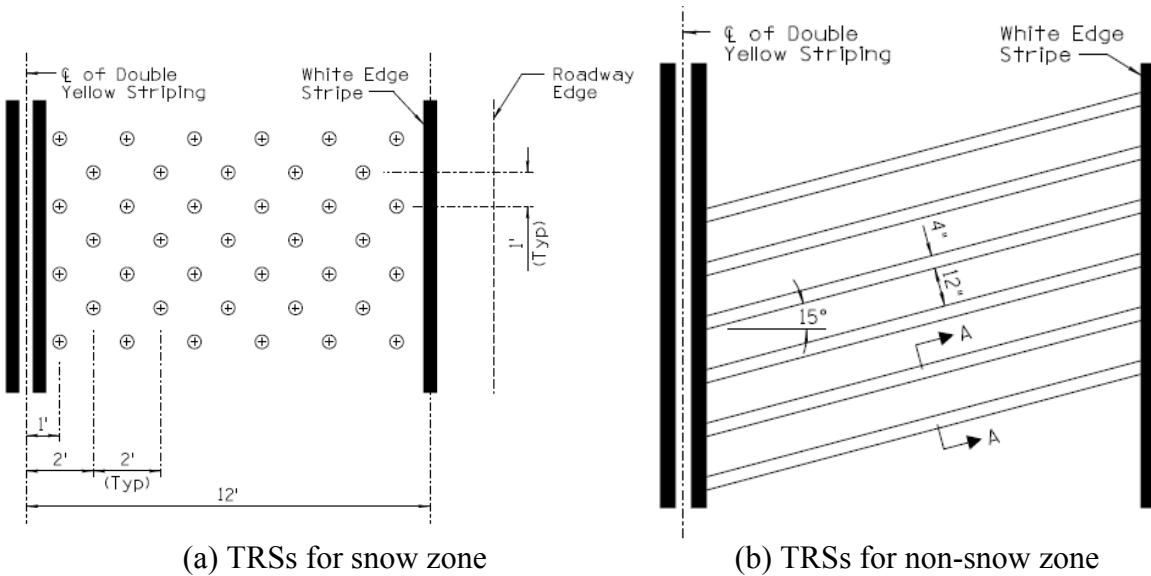

Figure 2 Arizona DOT TRS details (ADOT 2014)

2.2 TRS EFFECTIVENESS EVALUATION

The primary goal of TRS design and application is to improve safety along the roadway through reductions in crash number and severity. Therefore, the ultimate measure of effectiveness (MOE) would be an evaluation or analysis of changes in crash experience. A study by the Virginia DOT documented a 37 percent reduction in total crash frequency and 93 percent reduction in fatal crashes for the stop-controlled intersections (VDOT 1983). The crash rate for rear-end and ran-stop-sign accidents was reduced by 89 percent (FHWA 1998). NCHRP Synthesis 191 summarized ten before-and-after studies that investigated the safety effectiveness of TRS. The reported crash reduction ranges from 14 to 100 percent (Harwood 1993). The most recent study examined the impacts of TRS based on Minnesota DOT and Iowa DOT data sets from rural intersections with minor-leg stop controls (FHWA 2012). For four-leg intersections, there was a statistically significant reduction in KA and KAB crashes (K=Fatal, A=Incapacitating Injury, and B=Non-Incapacitating Injury). For three- and four-leg intersections combined, there was a statistically significant increase in PDO crashes (about 19 percent), a statistically significant reduction in KAB crashes (about 21 percent), and KA crashes (about 39 percent) (C=Possible Injury, and PDO=Property Damage Only).

The attention-getting effects of rumble strips were normally measured by noise levels in contrast to baseline conditions. Some researchers considered increases of 4 dB or greater to be sufficient to alert drivers coming into contact with rumble strips (Watts 1977, Elefteriadou et al. 2000, Miles and Finley 2007). The study by Outcalt regarded a sound level of a 6 dB change as a “clearly noticeable change,” and 10 dB changes as twice as loud according to human perception of changes (Outcalt 2001). Tests by Walton and Meyer revealed an average increase in sound from TRS was 10 dB for cars and 4 dB for trucks and dump (Walton and Meyer 2002). Lank and

Steinauer found the A-weighted volume in the area of the TRS is, on average, 10 dBA above the basic noise level without TRS (Lank and Steinauer 2011). Horowitz and Nothbohm also measured the sound and vibration level generated by permanent cut-in-pavement (CIP) rumble strips and adhesive rumble strips (Horowitz and Notbohm 2005). The average sound level for both standard CIP strips at 40 and 55 mph was found to be respectively 75.2 and 75.8 dB, and 70.9 and 76.8 dB for the adhesive rumble strips. Schrock et al. tested 10 different configurations of 4–6 strips, 24 and 36 inch spacing plastic TRS and CIP strips spaced at 18-inch intervals and found that in-vehicle sound levels ranged from 79.4 to 85.0 dB for a truck and from 75.7 to 85.7 dB for the passenger car (Schrock et al. 2010).

The speed effect of TRS shows inconsistent results in previous studies. This explains why TRS was a treatment most states had an interest in for further evaluation based on the NCHRP's study of speed reduction treatments at high-speed intersections (NCHRP 2007). A 1962 study investigated the effectiveness of TRS installed at four different locations in Contra Costa County, California, and concluded that vehicle speeds and deceleration rates before a sharp curve were reduced (Kermit and Hein 1962). Shaik et al. compared the effect of white lane drop arrows, the citizens band (CB) wizard alert system, and orange rumble strips on vehicle speeds for the Interstate 70 near Columbia, Missouri (Shaik et al. 2000). The study showed only small effects on vehicle speeds when compared to the CB wizard alert system alone. Fitzpatrick et al. conducted a before-and-after study of TRS in 11 sites in Texas (Fitzpatrick 2003). The field data revealed statistically significant changes in mean and 85th percentile speed on approaches with the TRS. Generally, the speed changes were less than 4 mph, with most being drivers slowing 1 to 2 mph. Thompson et al. investigated speed changes due to TRS on approaches to high-speed stop-controlled intersections and reported that the installation of TRS generally produced small,

but statistically significant ($p \leq 0.05$) reductions in approach speeds. In a few instances, speed change reductions of greater than 1 mph occurred; however, the overall trend was for speed change reductions to be equal to or less than 1 mph (Thompson et al. 2006).

To analyze driver behaviors, Minnesota DOT initiated a series of studies. The first phase investigated attentive driver stopping performances in a driving simulator, and the results indicated that TRS caused drivers to use their brakes more and to apply them earlier (Harder et al. 2001). The second study of the series focused on sleep deprived drivers, and the third study found that after drivers encountered the first set of TRS, they slowed down earlier in real-world approaches where TRS were present than where they were not; on average, the difference was 2.0 to 5.0 mph (Harder et al. 2006). Miles et al. (2006) studied TRS installed at two rural stop-controlled intersection approaches near College Station, Texas. No sudden breaking or swerving maneuvers were observed for either site. The research of Wang et al. addressed TRS installed in work zones on rural two-lane highways in Kansas. It was observed that 30 to 80 percent of all drivers activated their brakes when they approached TRS closest to flagger (Wang et al. 2013).

Previous studies revealed that crash history, vehicle speed, driver behavior as well as sound and vibration were measures of TRS effectiveness. A crash-based evaluation is the ultimate measure, but relatively difficult because of insufficient availability of a crash data set. Other complications arise due to bias, inaccuracy, and confounding effects within the crash database (Perkins and Bowman 2000, Zhou et al. 2015). To mitigate use of crash experience as the sole criterion, surrogate crash measures were recommended for use as an operational review tool and as an indication of effectiveness. The primary MOE used in this study include measures of perceptibility (sound and vibration), measures of driver response (speed changes and braking behavior), and measures of cost (installation and removal).

CHAPTER 3

METHODOLOGY

In order to achieve the objectives of this study, the methodology herein is divided into three main parts. Section 1 outlines the testing plan to examine the effectiveness of existing TRS, and the instrumentation for obtaining noise and vibration levels inside the vehicles. The field data obtained in the initial phase provides references for DRS conceptual designs and effectiveness evaluation. In Section 2, a survey of transportation professionals was designed to collect views on the DRS patterns and determine the cost, materials, patterns, and installation procedures for DRS. The final section describes the process of DRS field tests at the NCAT of Auburn University. Each design concept was evaluated by extensive field testing of appropriate sound and vibration levels.

3.1 INITIAL FIELD TEST OF TRS EFFECTS

The first stage of this study aims to verify the feasibility of using DRS as a safety treatment, and quantify the driver perception of interior sound and vibration. Therefore, the impacts of existing TRS on driver behavior was measured in terms of the sound and vibration they feel inside the vehicle, their speed choice, and braking behavior when approaching the TRS. Particular attention was given to TRS on the approaches to the high-speed intersections with typical installations in Alabama.

3.1.1 TRS Site Description

To compensate for the bias from single site testing, five TRS deployments were selected for field tests along US 280 in Auburn, Salem, Smiths Station and Phenix City. The TRS were used

at these sites to supplement existing warning signs (Signal Ahead). The five sets of TRS were applied between 500 ft. downstream of the SIGNAL AHEAD (W3-3) warning signs and 486 to 1,350 ft. upstream of the intersections. The features and controls for the study sites are displayed in Table 2.

Table 2 Characteristics of TRS sites along US 280

Sites	City	2013 AADT	Intersection Type	Posted Speed Limit (mph)	TRS distance from Intersection (ft.)	Traffic Signs Upstream of TRS
US 280/ Grand National Pkwy	Auburn	15,490	Signalized	65	680	SIGNAL AHEAD (W3-3)
US 280/ CR-250	Salem	17,610	Unsignalized	65	486	SCHOOL BUS ENTERING AHEAD (S3-1B), INTERSECTION WARNING SIGNS (W2-1)
US 280/ CR-430	Smiths Station	20,200	Signalized	65	818	SIGNAL AHEAD (W3-3)
US 280/ CR-248	Smiths Station	20,840	Signalized	65	813	SIGNAL AHEAD (W3-3)
US 280/ CR-240	Phenix City	20,810	Signalized	55	1,350	SIGNAL AHEAD (W3-3), SPEED LIMIT (R2-1)

Alabama Traffic Data: <http://algis.dot.state.al.us/atd/default.aspx>.

The layout and dimension of the tested TRS are detailed in Figure 3. The thermoplastic strips used were 24 ft. long covering two traffic lanes, 5.5–9.0 in. wide and 0.11–0.21 in. thick. They were spaced at 8.5–10 in.

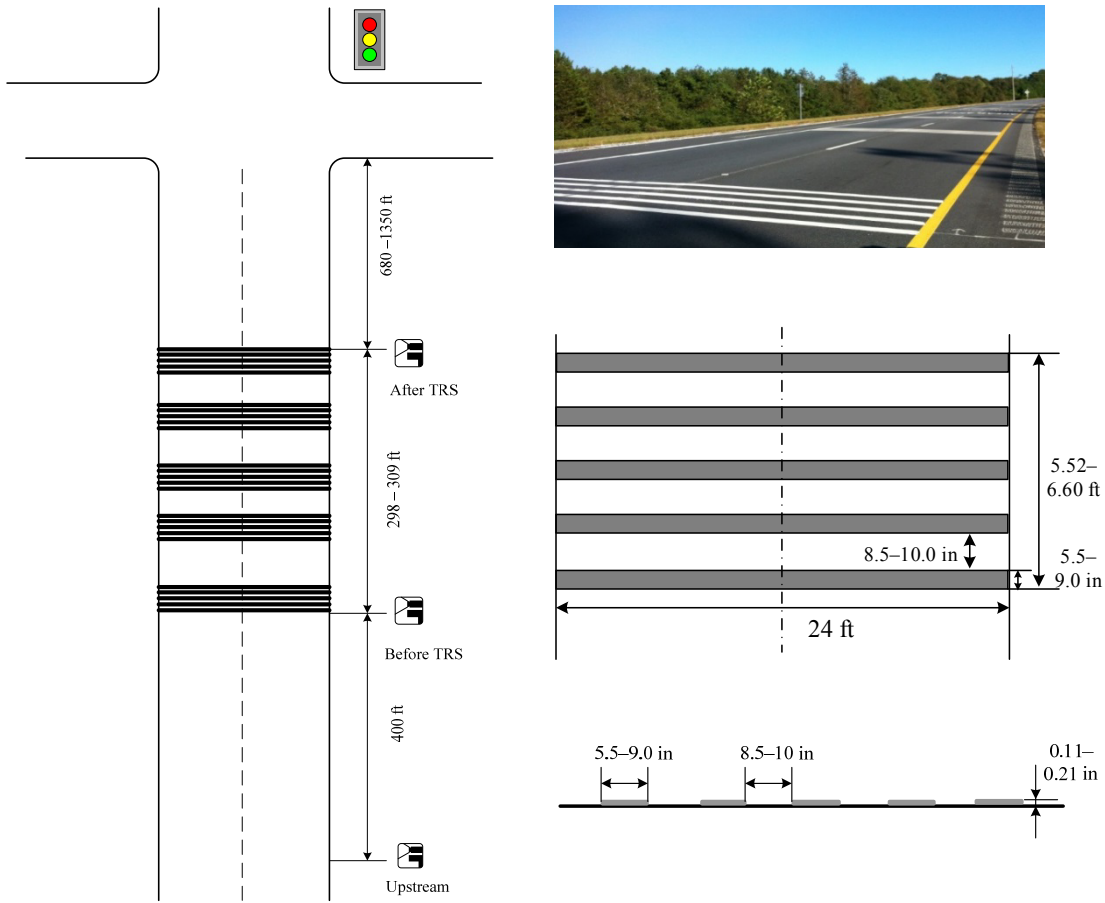

Figure 3 TRS layout and configurations at study sites

3.1.2 Interior Noise Level and Vibration Testing

To better understand how the driver would perceive the TRS, sound and vibration inside the vehicle were measured by an equipped passenger car (2010 Ford Fusion). The acoustical signature was recorded by an Extech HD600 Sound Level Meter that displays 10 decibel readings during any one-second period. Figure 4 shows sound levels in dBA for common sounds. Humans have difficulty hearing very low or very high frequency sounds. The A-weighted sound level accounts for this characteristic of human hearing, so that the recorded data are more representative of what a typical human would perceive. The vibration data was recorded using a Measurement Specialists 35201A accelerometer, which operates at 124 samples per second.

These devices allowed researchers to measure acceleration rates along the longitudinal, lateral, and gravitational axes.

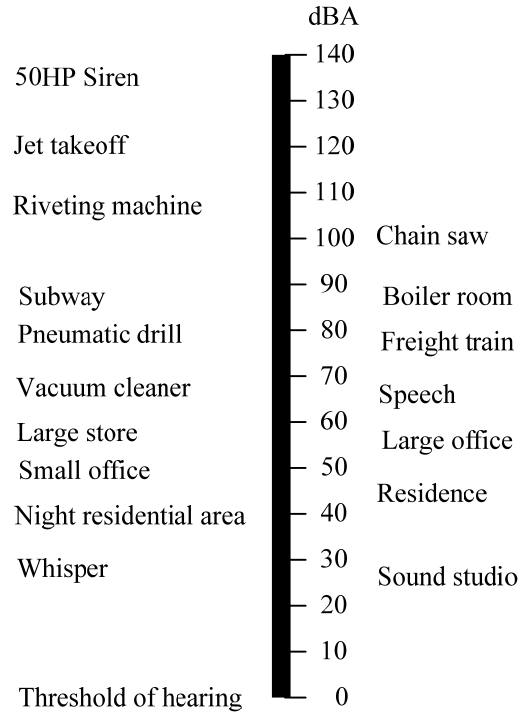

Figure 4 Typical A-weighted sound level

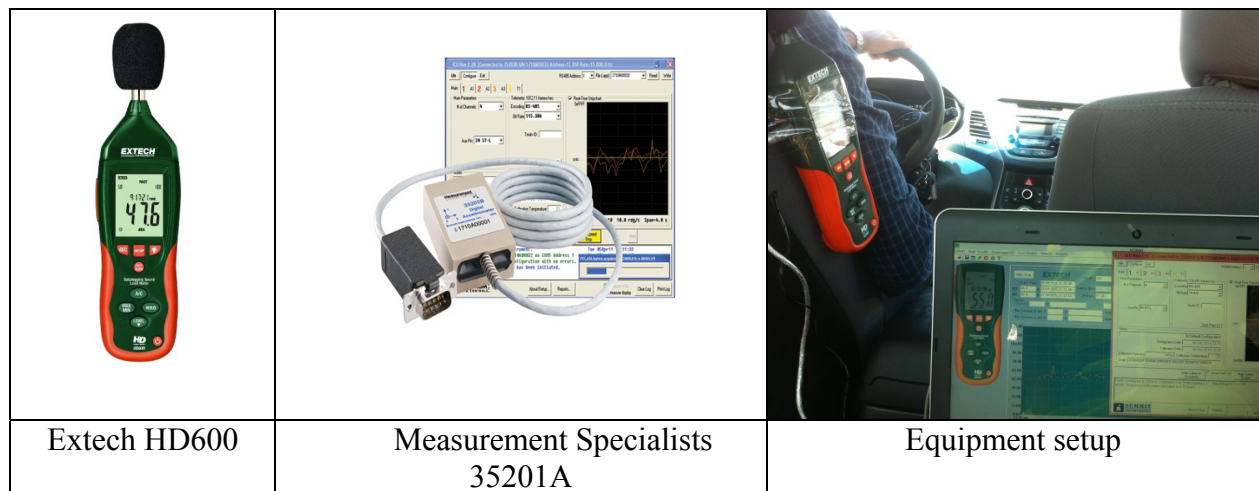

Figure 5 Sound and vibration measurement instruments and test setup

Figure 5 shows the testing experimental setup. The sound-level meter was located at an average driver's ear height and the tri-axial accelerometer was fixed between the driver and the

passenger's seat. Both the sound level meter and accelerometer were controlled by a laptop computer via the equipment software and serial port. After conditioning the sound and vibration signals, all information was stored directly to Microsoft Excel for later analysis. While the tests were conducted, the air-conditioner, stereo, and any other noise-producing sources were turned off, and the windows were rolled up, to eliminate as much background noise as possible.

While the vehicle was driven down the roadway, the signatures of the ambient and TRS conditions were recorded. The ambient condition was defined as the sound and vibration associated with the test vehicle traveling at a specified speed along the roadway 300 ft. before the TRS. The rumble strip condition refers to the stimuli inside the testing vehicle traveling with at least one tire coming into contact with the TRS. For statistical support and to compensate for any small fluctuations in the measurements, at least six test runs were completed for each TRS design, and three runs for the ambient condition for each speed category.

3.1.3 Vehicle Speed and Driver Behavior Measurement

The actual speed changes attributable to the TRS might not be fully realized at the data points located on the strips, but more likely occur downstream of the strips. The study investigates driver speed choice in response to the TRS by comparing vehicle speed in the upstream location, before TRS location, and the after TRS location. Vehicle speed data were measured using a Stalker radar gun with a 5–150 mph speed range and ± 0.1 mph accuracy. The upstream collection points were placed significantly in advance (400 ft.) of the treatment application, where drivers cannot see the TRS and vehicle speeds will not be affected by the presence of the TRS or the intersection. The radar speed measurement was also taken at the point where the TRS would first become visible to the driver, i.e., the point at which the driver might first react to the presence of the TRS. The speed at which vehicles rolled over the TRS and were ready to enter the intersection was measured in close proximity to the intersection. The distances

from the intersections are listed in Table 2, and the speed data collection points are shown in Figure 3.

Another common measurement that is used to obtain a better understanding of driver response is the braking behavior. As part of this research, video cameras were placed upstream of the TRS at each site during the data collection period. The video recordings were used to analyze driver braking, swerving, or shifting maneuvers when going through the TRS. With few exceptions, data collection was performed only on Tuesday through Thursday and under clear weather conditions with dry pavement. The data were collected over a period from March 14 to May 29, 2015 and split into daytime and nighttime data sets. Daytime was taken as being between 8:30 AM and 5:30 PM. Nighttime was taken between 8:30 PM and 12:30 AM for all the sites.

3.2 NATIONAL SURVEY

A national survey was initiated to collect the comments and suggestions for conceptual designs from transportation professionals who are knowledgeable about rumble strips design, manufacturing, or installation. The survey questionnaire (Appendix A) consists of two major parts. Part one provides a brief introduction of the background and objective of the project, and Part two includes five questions related to DRS conceptual design. Question 1 highlights the feasibility of using DRS as a warning system to discourage wrong-way drivers. Question 2 asks the participants to rate the proposed DRS patterns by scale 1 (“Absolutely Inappropriate”) to 7 (“Absolutely Appropriate”). For each pattern, the generalized diagram was provided, and a brief illustration was used to further clarify the concept. Question 3 ranks the properties of the DRS based on the expectation of their potential to reduce wrong-way driving. The priority is scaled from 1 to 5, representing “Low Priority” to “High Priority.” Question 4 and 5 encourage the

participant to provide more ideas and concepts about DRS, and also should provide the materials, cost, and installation procedures.

The survey was reviewed and approved by the Auburn University Institutional Review Board (IRB). The online survey was created by Qualtrics software and then distributed to 242 selected transportation professionals who work for pavement marking vendors, state DOTs and local agencies. The authors of previous studies related to rumble strip designs or field tests were also included in the contact list. The phone interviews were conducted with several pavement marking vendors like Advanced Traffic Markings (ATM), Ennis-Flint, SWARCO, Peek Pavement Marking, TAPCO (Traffic & Parking Control Co.), Garden State Highway Products, etc.

3.3 DRS FIELD TEST

The sound and vibration levels produced as a vehicle traverses the DRS were used as the principle measures of effectiveness. The following sections outline the methods used to collect the sound and vibration data for the proposed DRS patterns.

3.3.1 Test Locations

The DRS field tests were conducted at the pavement test track of the NCAT at Auburn University. Different patterns of DRS were deployed on the entrance ramp at the Auburn University Erosion and Sediment Control Testing Facility (AU-ESCTF) at NCAT. Figure 6 shows the testing location, which has two 12 ft. lanes and closed facilities during the study period. The testing road has a 1,091 ft. tangent section, which provides appropriate space to install different DRS patterns (25 ft. to 190 ft.) and accommodates the need for frequent acceleration and deceleration of the testing vehicle.

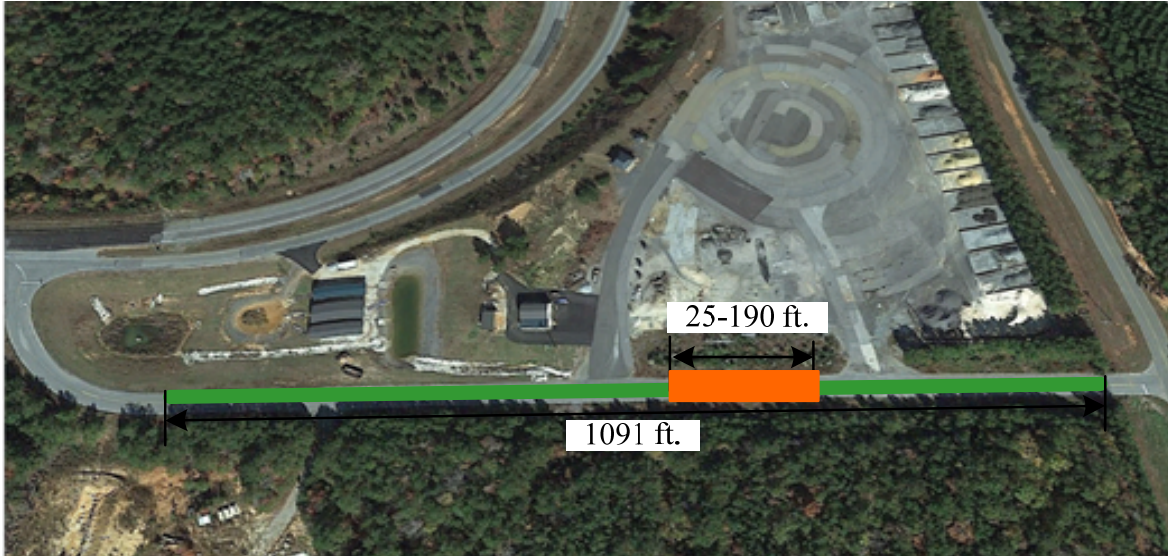

Figure 6 Testing locations at NCAT

3.3.2 Test Schemes

Using the same testing vehicle and equipment setup in the initial field test (Figure 5), noise and vibration data were collected for both right-way and wrong-way directions for different DRS patterns. The experimental vehicle traveled through both directions at the speed of 10 mph, 15 mph, 20 mph, 25 mph, 35 mph, and 45 mph, respectively. These are the typical approach speeds at different segments of exit ramps. The sound and vibration measurements were also taken for both DRS patterns and smooth pavement. The smooth condition was defined as the test vehicle traveling at a specified speed along the roadway section before DRS implementation. The rumble strip condition refers to the same road segment with installation of the DRS patterns. At least six test runs were completed for each DRS configuration for each direction and speed category. As listed in Table 3, data collection was performed from August 27th to 29th, and November 22nd to 24th, 2015. During the first test, five different configurations were evaluated for the speed range of 25 mph, 35 mph, and 45 mph. In the second test, six configurations were installed and tested for all the speed ranges. At the end of the first test, the collected data were examined to determine which configurations had performed the best in order to plan more focused testing

during the second test. The Pattern B Configuration 2 and Pattern D Configuration 1 were not tested for more speed ranges in the second stage due to the unsatisfactory results.

Table 3 DRS field test schemes

Date	Test patterns and configurations	Test speed (mph)	Total runs
August 27–29, 2015	Pattern B Configuration 1	25, 35, 45	18
	Pattern B Configuration 2	25, 35, 45	18
	Pattern C	25, 35, 45	18
	Pattern D Configuration 1	25, 35, 45	18
	Pattern D Configuration 2	25, 35, 45	18
	Smooth Surface	25, 35, 45	9
November 22–24, 2015	Pattern B Configuration 1	10, 15, 20, 25, 35, 45	72
	Pattern B Configuration 3	10, 15, 20, 25, 35, 45	72
	Pattern C	10, 15, 20, 25, 35, 45	72
	Pattern D Configuration 2	10, 15, 20, 25, 35, 45	54
	Pattern D Configuration 3	10, 15, 20, 25, 35, 45	72
	Pattern E	10, 15, 20, 25, 35, 45	72
	Smooth Surface	10, 15, 20, 25, 35, 45	27

3.3.3 DRS Installations

Two types of rumble strips were purchased from vendors to constitute different configurations of DRS. Figure 7 displays the rumble strips from different vendors. The black TAPCO rumble strips (Figure 7a) were produced as 23.5 in.×3.5 in.×0.5 in., and were applied to the pavement using mixed epoxy provided by the manufacturer. The removable rumble strips from ATM (Figure 7b) are non-reflective, self-adhesive, and come in 50 ft. rolls. The white removable rumble strips were first cut to the appropriate length using tin snips. The adhesive, which was pre-applied to the strip by the manufacturer, was exposed by removing the protective backing.



Figure 7 Rumble strips from vendors (a: TAPCO; b: ATM)

The DRS was installed following the standard procedure when pavement was dry, and its temperature just before installation was warmer than 10° C (50° F). The pavement was swept with a push broom to remove loose debris. Once the pavement was clean, it was marked using masking tape to indicate the proper placement for the strips.



(a) (b)
Figure 8 DRS Installation (a: TAPCO; b: ATM)

CHAPTER 4

ANALYSIS AND RESULTS

This section presents key results from the analysis and summarizes the significance of each result. With a large amount of data captured, many plots can be generated. This section limits attention to those of greatest interest to the detectability problem. The results start with the initial field test, move onto DRS conceptual designs and national survey, and finish with DRS field test analysis.

4.1 INITIAL FIELD TEST RESULTS

On completion of the data collection, the data were analyzed to determine statistically significant correlations between the TRS and changes in traffic operational characteristics. The following subsections describe the effects of TRS on the sound and vibration generated, and the speed changes due to driver responses to TRS.

4.1.1 Sound and Vibration Effects

There exists a direct relationship between the levels of sound and vibration produced and the driver's perception of the strips. Figure 8 shows an example of the sound and vibration wave profiles recorded for one tested site. Similar trends were observed on other TRS sites. Based on the sound waveforms, it appears that the strips provided significantly higher sound than the baseline conditions for each of the incursions. For speeds of 60 mph, the normal sound in the cabin of a passenger car was around 62 dBA, and the sound level reached 76.9 to 80 dBA when coming into contact with the TRS. When referring to the sound levels in dBA for common sounds in Figure 4, the sound level equals a freight train and a pneumatic drill. The plot of

acceleration indicates the elevated vibration associated with each strip application. The vibration increases were observed not only in gravitational axis, but also for the longitudinal and lateral directions. Considering the vertical axis, the vibration retained 1.06 g (10.39 m/s²) for the baseline condition and fluctuated from 0.83 to 1.15 g (8.13–11.27 m/s²) due to TRS installment.

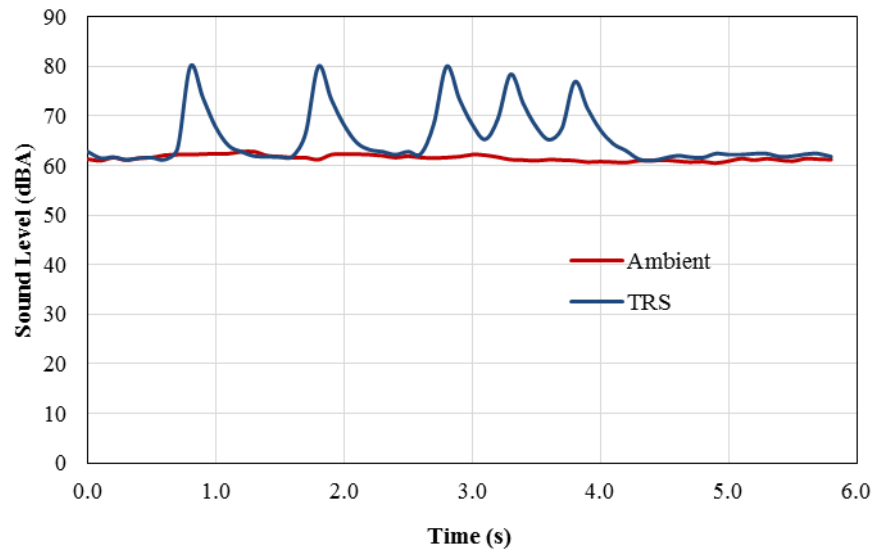

(a)

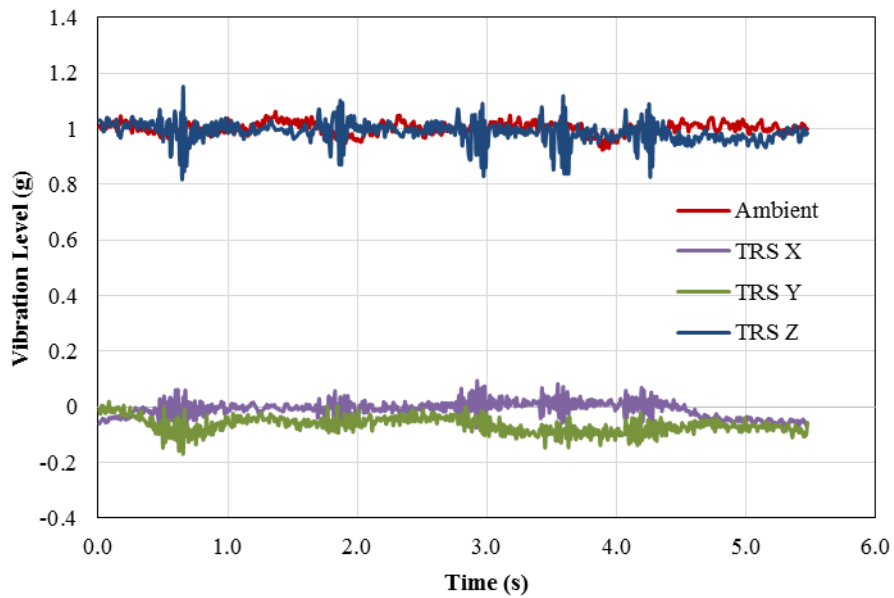

(b)

Figure 9 Sound and vibration of TRS in Phenix City with vehicle speed of 60 mph
(a: A-weighted sound level; b: vibration between seats)

Additional figures (Figures 9a and 9b) were generated to compare sound levels and acceleration rates under different driving speed ranges. It appears that the four tested TRS produced improved acoustical and tactical performance relative to the baseline pavement. For sound levels under different speeds, the A-weighted sound volume on the TRS was within the range of 70.9 dBA to 80.8 dBA for all the tested sites. The rising trend in sound was observed for both ambient and TRS conditions. The vibration signal along the vertical axis results 1.09 g to 1.25 g (10.68 to 12.25 m/s²) when considering the TRS incursion vs. normal pavement surface.

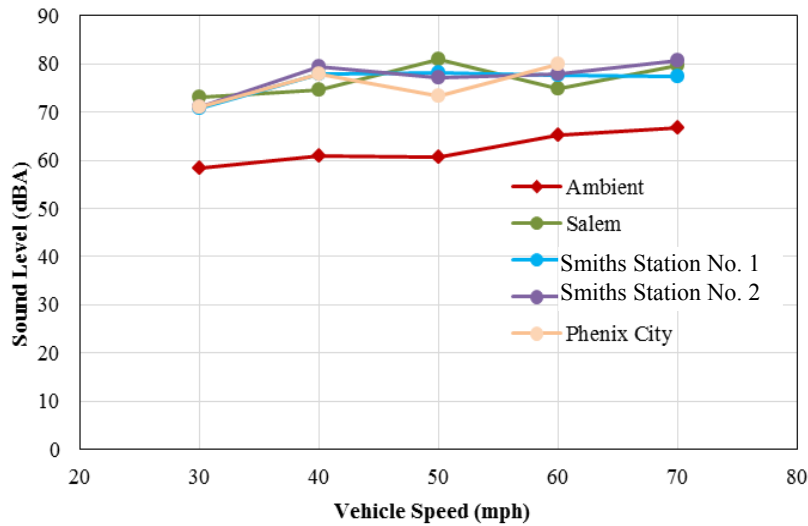

(a)

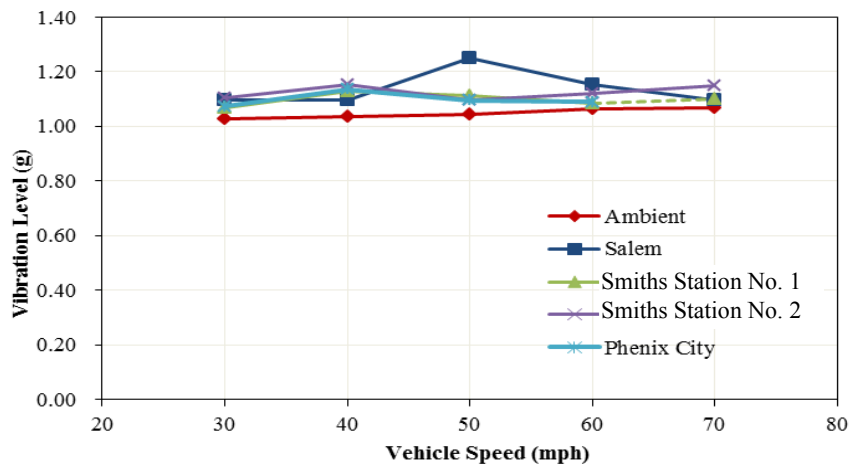

(b)

Figure 10 Sound and vibration level vs. vehicle speeds
(a: maximum A-weighted sound level; b: maximum vertical vibration)

A multiple-factor analysis of variance (ANOVA) was performed to further compare TRS and ambient conditions with a 95% confidence level. For the tested TRS, a statistically significant difference was observed for all the instances, except for Smiths Station No. 1 at a speed under 60 mph and 70 mph ($p = 0.188$ and $p = 0.112$). The TRS vibration was also significantly different from the ambient condition except for at 50 mph for Smiths Station No. 1 and 60 mph at Smiths Station No. 2 ($p = 0.091$ and $p = 0.389$).

Table 4 In-vehicle sound and vibration comparison

Speed (mph)	Sound level change (dBA)					Vibration change (g)				
	30	40	50	60	70	30	40	50	60	70
Ambient	58	61	61	65	67	1.03	1.04	1.04	1.06	1.07
Salem	+15	+14	+20	+10	+13	+0.07	+0.06	+0.21	+0.09	+0.03
Smiths Station No. 1	+13	+17	+18	+12	+11	+0.04	+0.09	+0.07	+0.02	+0.03
Smiths Station No. 2	+13	+18	+17	+13	+14	+0.07	+0.12	+0.05	+0.06	+0.08
Phenix City	+13	+17	+13	+15	-	+0.04	+0.10	+0.05	+0.03	-

Note: highlighted values show statistically significant difference and noticeable increases.

Table 4 describes sound and vibration changes when comparing the TRS with the ambient condition under the speed range from 30 mph to 70 mph. The highlighted values show statistically significant differences and noticeable increases. For all the test sites, the TRS produced noise levels 10 dBA to 20 dBA greater than the baseline sound level, averaging 14 dBA increases. The average rise in acceleration is 0.069 g (0.68 m/s²). The effectiveness of rumble strips is a function of not only the sound and vibration levels occurring, but also of human perception. As aforementioned, to become aware of a sound and be “alerted to the presence of that sound, the sound must typically rise 6 to 10 dBA above the background sound level.” In this experiment, 6 dB is a more appropriate threshold for considering a difference to be practically significant in field tests. The threshold at which differences in vibration become detectable by humans is not well defined. Most studies involving the perception of vibration

typically rely on simple harmonic vibrations caused by machines, which are quite different from the vibrations consisting of a wide range of frequencies and amplitudes experienced while driving over rumble strips (Green and Wright 1959). Additionally, the measures used are generally subjective, and therefore an objective threshold is difficult to specify (Harris 1987, Smith 1989). In light of these complicating issues, the 2.5 to 4.25 m/s² (0.26 to 0.43 g) change in previous studies (Lank and Steinauer 2011, NCHRP 2007) is taken as the threshold of perceptibility of vibration in this study.

4.1.2 Effects on Vehicle Speed

Speed reductions were used as a secondary MOE, because the effectiveness of TRS at reducing speeds is arguable. The speed data collected on each set of strips was analyzed as a whole and for several subgroups. The subgroups were created based on ambient lighting conditions (day or night), distances from the TRS to the intersection, as well as the signal indications (green or red light) when a vehicle approaches the intersection. The ANOVA was used to determine if the TRS caused a significant reduction in vehicle speeds. Tukey's Honest Significance Test was used to compensate for the biases generated by using a single statistical test. All tests were performed at a 95% confidence level ($p \leq 0.05$) with the null hypothesis of an equal mean speed for before and after TRS locations. Statistical descriptions of the collected speed data for all the sites are given in Table 5. The average speed reductions ranged between 0.95 to 8.63 mph, and from 0.84 to 9.71 mph for the 85th percentile speed. The statistical analysis results showed that speed reductions for all the tested TRS were statistically significant at a 95% level, except for the Salem daytime condition. Although the ANOVA generated an acceptable F -statistic (38.72) and p -value ($0.000 < 0.05$), Tukey's method yielded a different result ($p = 0.15 > 0.05$). The insignificant speed difference for Salem was also observed for the

daytime average speed and 85th percentile speed, which was probably because the TRS was installed on an approach to an unsignalized intersection.

Table 5 Traffic speed characteristics at observed locations

Site	Lighting Condition	Overall Sample Size	ΔV_{mean}^a	$\Delta V_{85\text{th}}^b$	ANOVA		Tukey
					F-statistic	p-value	p-value
Auburn	Daytime	550	0.95	0.84	33.44	0.00	0.02
	Nighttime	440	3.72	1.07	18.28	0.00	0.00
Salem	Daytime	638	-0.96	-0.42	38.72	0.00	0.15
	Nighttime	532	4.20	5.60	33.45	0.00	0.00
Smiths Station No.1	Daytime	651	2.15	1.04	91.86	0.00	0.01
	Nighttime	387	4.84	5.08	14.46	0.00	0.00
Smiths Station No.2	Daytime	624	8.63	9.71	227.1	0.00	0.00
	Nighttime	351	5.00	4.37	22.17	0.00	0.00
Phenix City	Daytime	612	3.10	3.10	30.3	0.00	0.00
	Nighttime	500	8.12	7.24	63.02	0.00	0.00

a—difference between the average speed of before TRS and after TRS locations.

b— difference between the 85th percentile speed of before TRS and after TRS locations.

Figure 10 shows the trend line of the 85th percentile speed at the upstream location (400 ft. before TRS), right before TRS and right after the TRS locations at daytime and nighttime. It can be observed that during both daytime and nighttime, the 85th percentile speed has a decline trend when approaching the TRS and intersections. The greater speed reductions were observed at sites with the higher initial speeds. Another observation is that the proportion of drivers who exceeded the permitted speed limit on average was reduced from 62% upstream to 26% after the TRS during the daytime and from 48% upstream to 24% after TRS during nighttime. The speed curve of Phenix City fell into a lower speed range due to the low speed limit of 55 mph, while the Salem speed line was in a high speed range because of unsignalized conditions.

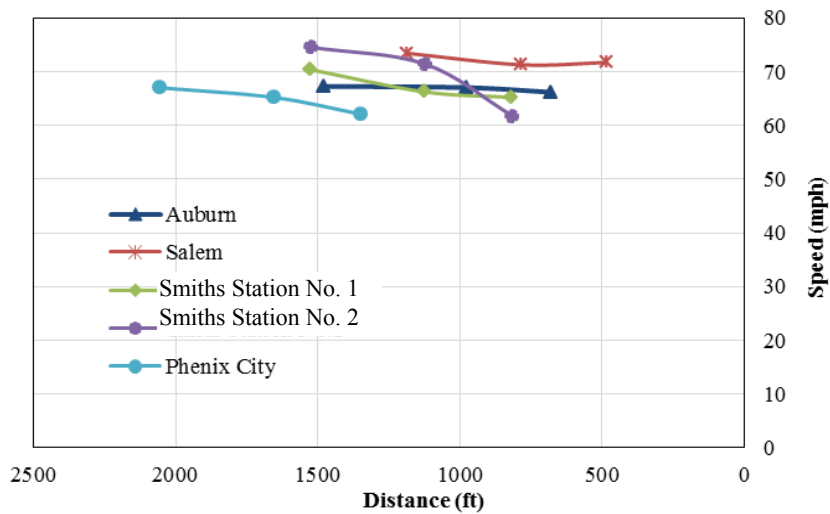

(a)

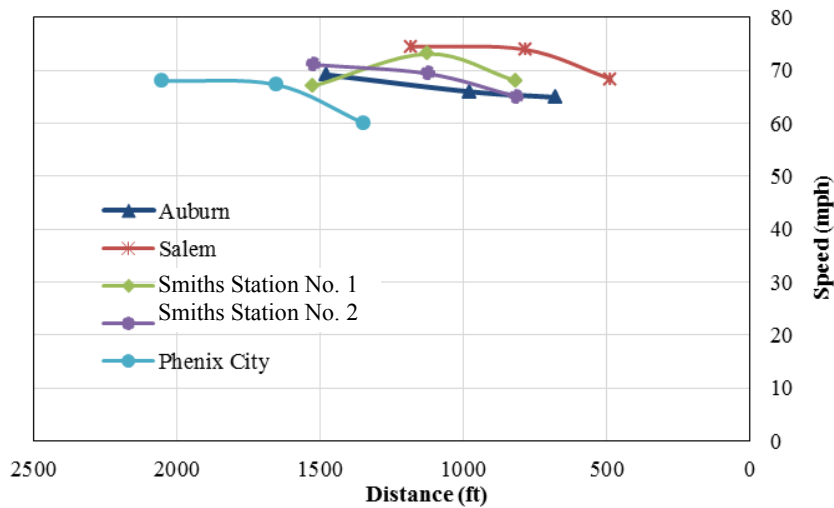

(b)

Note: the origin represents the intersection.

Figure 11 Speed changes along the TRS treatment (85th percentile speed, a: daytime, b: nighttime)

Another factor considered in this study was traffic signal indication because vehicle deceleration may be affected by the signal indication displayed when approaching an intersection. Figure 11 illustrates the speed change at an 85th percentile speed. The overall speed reduction during the daytime was 3.47 mph for a green light ahead, and 5.02 mph when the red light was visible. During the night, the speed reduction was 5.24 mph when there was a green light ahead, and 8.08 mph when the red light was visible. In the ANOVA test, the effects of a traffic signal

were unperceivable for Phenix City during both day and night conditions ($p = 0.509$ and 0.286 , respectively), which is probably due to the longer distance from the TRS to the intersection (1,350 ft.). At other sites like Auburn and Smiths Station, TRS speed reductions were increased when the red light was visible, especially during nighttime conditions.

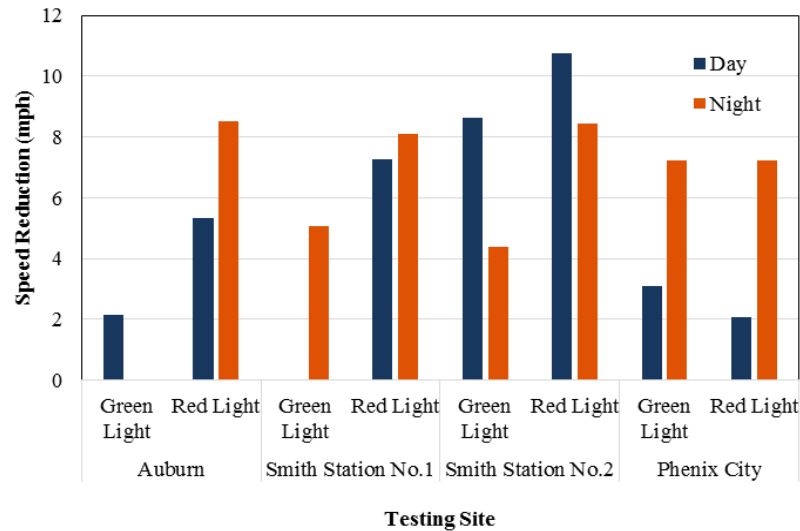

Figure 12 Speed reduction for green light and red light ahead (85th percentile speed)

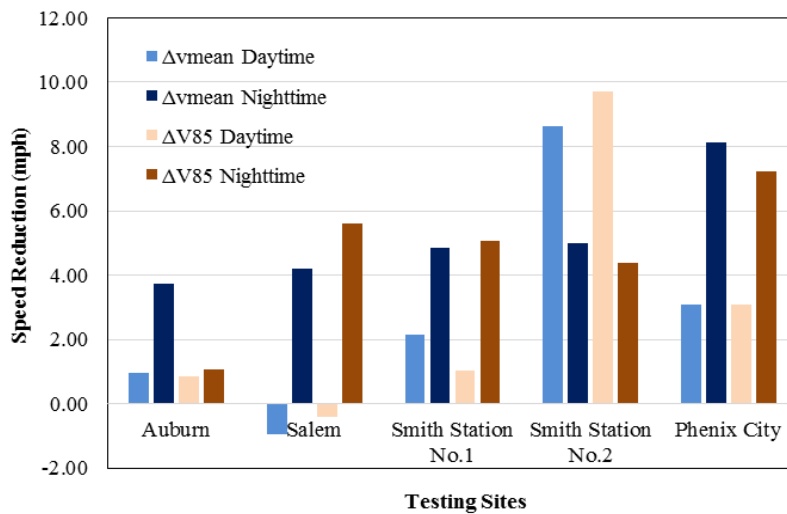

Figure 13 Speed reduction by ambient lighting conditions (V_{mean} and V_{85th})

The study also found that average speed reduction was different between daytime and nighttime periods. Except for the dataset for Smiths Station No. 2, all study sites had a larger average vehicle speed reduction during the nighttime than the daylight condition. The Auburn

site had a 0.95 mph speed reduction during the day and a 3.72 mph speed reduction during nighttime. The ANOVA test indicated that vehicle speed was statistically different for day and night conditions at three locations (upstream, before TRS and after TRS), and the speed reduction was more effective during nighttime than in daytime periods with the majority of data set generating a $p \leq 0.05$. The results indicated that TRS were visible at night and drivers may be more cautious at night about approaching conditions due to unfamiliarity with the roadway, drowsiness, or other inhibiting factors.

4.1.3 Driver Behavior

Another important measurement is driver reaction to TRS. In this study, unusual behavior was not observed, such as intensive deceleration in front of the strips or moving partly onto the shoulders to avoid the TRS. The effects on driver speed choice were deduced from the standard deviation (SD) of the collected speed data. For the upstream data sets, the SD remained 4.25 mph to 6.02 mph from site to site, and the SD was 6.34 mph to 9.04 mph for the before TRS or after TRS locations. The increase in speed variance indicated that some drivers slowed down more than others in response to the treatment and intersections. The statistics on driver braking behavior is listed in Table 6.

Table 6 Statistics of driver behavior observations

Site	Lighting Condition	Cars			Trucks		
		N	Brake Light Applied	Percentage (%)	N	Brake Light Applied	Percentage (%)
Auburn	Daytime	252	208	82.54	156	124	79.49
	Nighttime	61	36	59.02	35	27	77.14
Salem	Daytime	258	55	21.32	139	40	28.78
	Nighttime	268	54	20.15	107	45	42.06
Smiths Station 1	Daytime	529	217	41.02	226	102	45.13
	Nighttime	146	33	22.60	43	28	65.12
Smiths Station 2	Daytime	285	74	25.96	183	87	47.54
	Nighttime	120	21	17.50	38	30	78.95
Phenix City	Daytime	366	267	72.95	209	166	79.43
	Nighttime	224	116	51.79	100	62	62.00

For the TRS installed at an unsignalized intersection (Salem site), around 20% of cars applied their brakes as they traverse the TRS, and the percentage of trucks with their brake lights on was 28.78% during the daytime and 42.06% during nighttime. For the signalized intersections, the percentage of braking behavior was inconsistent from site to site, but ranged between 40% to 80% among the sites. An increase in braking behavior was found at the second and third sets of TRS. From the two-sample test for equality of proportions with continuity correction, there was no significant difference between a truck and car in terms of braking during the daytime, but significant braking behavior during nighttime ($p = 0.670$ for daytime and $p = 0.009$ for nighttime), which means that truck drivers drive more cautiously during the nighttime, especially when they are approaching treatments and intersections.

4.2 CONCEPTUAL DESIGNS OF DRS

DRS can be regarded as a variation of TRS. When vehicles roll over the rumble strips from either direction, the conventional TRS provides motorists with the same levels of sound and vibration. The DRS is designed to generate elevated noises and vibrations to warn wrong-way drivers and normal noises and vibrations to slow down the traffic for the right-way direction when they are approaching exit ramp terminals. Tables 7 and 8 summarize the layout and configurations of TRS currently under implementation based on state DOT guidelines, practices in Alabama, and rumble strips vendors. The state DOT design guidelines are the summary of more recent leaders in TRS practice and research, including Minnesota, Maryland, Oregon, Arizona, Texas, Michigan, Montana, New Hampshire, etc. The Alabama practices are summarized by the field reviews of over 10 TRS sites. The recommendations from the vendors (such as ATM, SWARCO, Ennis-Flint, TAPCO, etc.) are also considered in this study.

Table 7 Layout of TRS

Resources	Number of sets	Length between set 1 and 2 (ft.)	Length between set 2 and 3 (ft.)	Length between set 3 and 4 (ft.)	Length between set 4 and 5 (ft.)
State Guidelines	2, 3, 4, 5	15–160	15–175	50–250	15
Alabama Practices	5	90, 100	80–100	40, 45, 50	40, 45, 50
Vendors	1, 2, 3, 4,	90–500	328–500	656	-

Table 8 Configurations of TRS

Resources	Strips in each set	Length (ft.)	Width (in.)	Spacing (in.)	Thickness (in.)	Offset (in.)
State guidelines	6–25	8-12	4, 5.5, 5.9 ±0.2	5.9, 12, 54, 72	0.375–15	6–12
Alabama practices	5	9, 12, 24	5.50-9.00	8.0–10.00	0.05–0.21	0
Vendors	6, 10	2, 3, 4	4, 6	12, 18, 24, 36, 60, 72, 120	0.25, 0.375, 0.5	0
This study	4, 5, 6, 7, 12	12, 10	4, 5	12, 24, 60, 120	0.25, 0.5	0

These dimensions provide references for the configuration and layout of DRS designs. In this study, the length of strips was designed to be 10 ft. or 12 ft. to fit one traffic lane. The width ranged from 4 in. to 6 in., and the thickness ranged from 0.25 to 1.0 in. The spacing among strips was used as 1 ft., 2 ft., and 5 ft. for the best sound and vibration effects.

To achieve the goal of different sound and vibration depending in travel directions, five conceptual designs of DRS have been selected from the pools of proposals, which are illustrated in Figure 13. Pattern A utilizes the removable rumble strips as the DRS. The height of the strips gradually increase from 0.25 to 1.0 in. by combining different thicknesses of tapes. In Pattern B, the raised wedge strips may offer audible and tactile signals of DRS. The 20 degree angle enables a gradual climb. The 90 degree edge makes it possible to create a more alarming feel for drivers traveling in the wrong direction. Pattern C attempts to create different audible and physical warnings by a varied number of strips and spacing among them. For Pattern D, the specifically shaped rumble strip features a set of triangles that provides visual effects. The length

of the strips decreases from 12 ft. to 1 ft. For the wrong way, the drivers encounter the increasing strip length, and the arrow gives a visual warning to the wrong-way drivers. In Pattern E, the triangle strips were designed to offer audible and tactile signals of DRS.

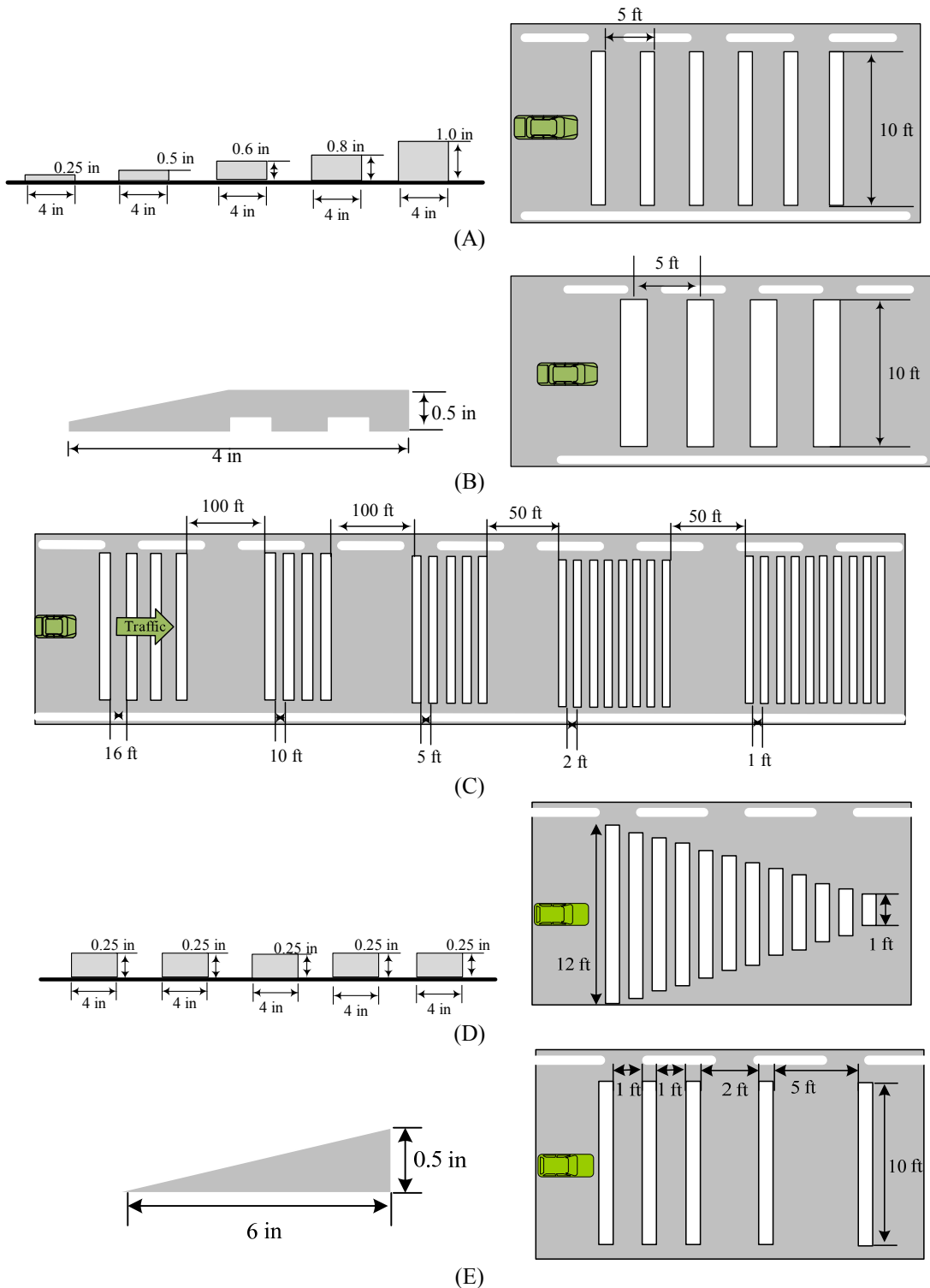

Figure 14 Conceptual designs of DRS

4.3 SURVEY RESULTS

The survey questionnaires were sent via the email to the selected 242 transportation professionals to collect their views on different DRS conceptual design. A total of 26 responses were obtained which constitutes an 11% return rate. As shown in Figure 14, among the respondents, 38% were ($n=10$) from pavement marking vendors, 15% were from state DOTs ($n=4$), 12% from manufacturers ($n=3$), 8% from consultants ($n=2$), and 19% ($n=5$) were researchers of universities.

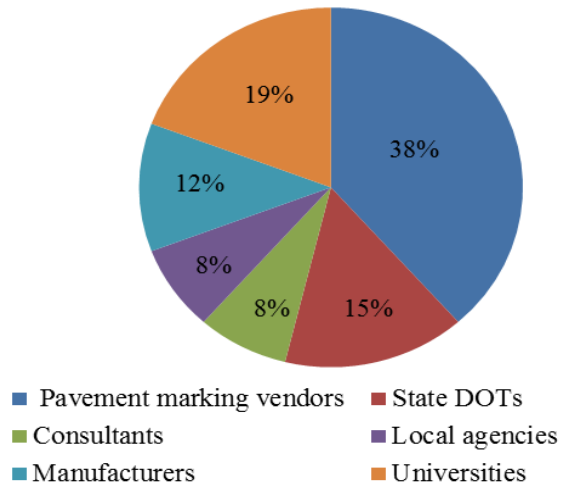

Figure 15 Response distribution

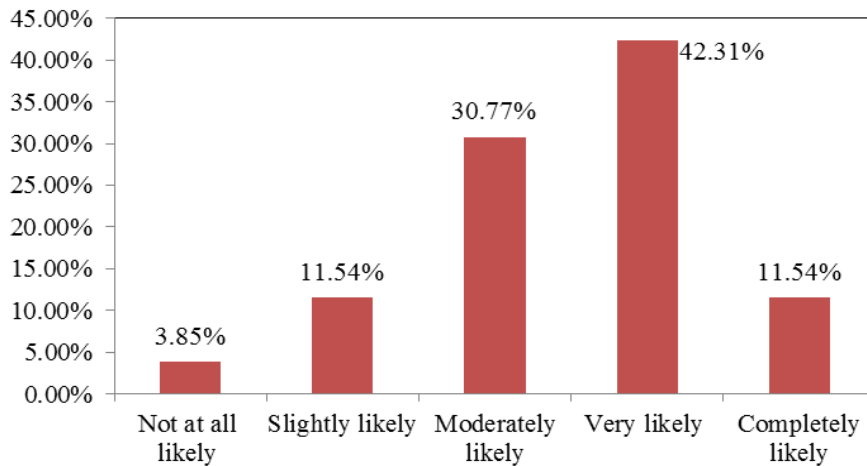
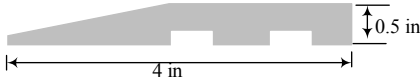
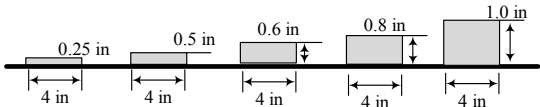
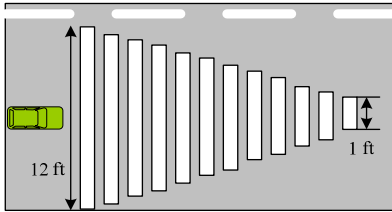
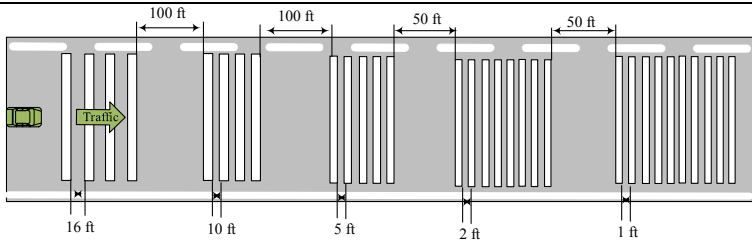

Figure 16 Survey results about feasibility of DRS for WWD

For the first question, participants were asked to rate the feasibility of DRS application. As shown in Figure 15, 42.31% of participants thought it was “very likely” to use DRS as a warning system on exit ramps for deterring WWD. 30.77% of respondents agreed “moderately likely”, and only 3.85% of participants answered “not at all likely.”

The participants were also required to rate the proposed design of DRS with the scale of 1 to 7, representing “absolutely inappropriate” to “absolutely appropriate.” As shown in Table 9, Pattern B (the raised wedge design of DRS) was expected to be the most appropriate pattern among all the designs. Pattern A (overlapped removable rumble strips as DRS) and Pattern D (triangle shaped DRS with decreasing length of strips) received the second place rating, and Pattern C (DRS with verified number of strips and spacing) was scored as 3.3.

Table 9 Rank of DRS conceptual designs

Pattern	Image	Score
Pattern B		4.0
Pattern A		3.5
Pattern D		3.5
Pattern C		3.3

As per the expectations about properties of the DRS of their potential to reduce WWD, the ranking of the properties is listed in Table 10 based on the scale of 1 to 5 of “low priority” to “high priority.” The result reveals that a minimum level of sound and vibration was the first concern of DRS properties. The optimum dimensions and visual attentiveness were also important to the developed DRS. Then the DRS were also expected to exert less noise impact on adjacent residents. Besides the listed properties, other aspects were suggested, such as skid resistance, effect on motorcycle, and low or moderate cost.

Table 10 Prosperity expectations of DRS

No.	Prosperities	Score
1	Minimum level of stimuli (i.e., sound or vibration) necessary to alert inattentive drivers	3.9
2	Optimum dimensions (e.g., length, width, depth, spacing)	3.8
3	Visual attentiveness (e.g., retro-reflecting properties and coloring)	3.8
4	Impact of noise produced by rumble strips on adjacent residents	3.7
5	Accommodation to motorists’ demands in adverse weather conditions, such as snow, fog, and rain	3.5
6	Effect on maintenance activities	3.5
7	Effect on pavement performance	3.0

The final part of the survey encouraged the participants to give some ideas or suggestions about the DRS conceptual design. Ennis-Flint recommended a thermoplastic profiled retro-reflective rumble in directional chevron, approximately \$ 9 per ft., and 250–375 mil thickness. Peek Pavement Marking, LLC suggested red retro-reflective color for the raised wedge design on the wrong-way side, with low cost. Traffic Calming Solutions proposed it would be possible to modify their Paver Rumble Strips to work with the Pattern A design, which are currently installed by contractors for approximately \$ 100.0 per lineal ft. (width). All these suggestions and recommendations will be considered for DRS designs and field tests in a later phase.

4.4 DRS FIELD TEST RESULTS

Four types of DRS designs were evaluated under the current stage: Pattern B (the raised wedge design of DRS), Pattern C (DRS with verified number of strips and spacing), Pattern D (triangle shaped DRS with decreasing length of strips), and Pattern E (a simple triangle design provided by the Peek Pavement Marking, LLC). In addition to comparing the proposed patterns, this study sought to examine the effects of various changes in the configuration of the strips on the sound and vibration levels produced. Data were collected for 8 configurations, as detailed in Table 11. As mentioned in Section 3.3.3, the rumble strips used for Pattern B Configuration 1 to Configuration 3 was the black TAPCO rumble strips (Figure 7a), with the dimension of 23.5 in.×3.5 in.×0.5 in. Pattern C and Pattern D Configuration 1 to Configuration 3 were formed by the ATM removable rumble strips (Figure 7b), which are approximately 0.25 in. thick and 4 in. wide. One group of strips was installed so that the effect of the changing variables on sound and vibration could be quantified.

Table 11 DRS field test configurations

No.	Configuration	Height (in.)	Width (in.)	Length (ft.)	Spacing (ft.)	Number of strips	Set and layout
1	Pattern B Configuration 1	0.50	4	12	5	5	1 set
2	Pattern B Configuration 2	0.50	4	12	5, 1	5	2 sets apart 5 ft.
3	Pattern B Configuration 3	0.50	4	10	5, 4, 3, 2, 1	6	1 set
4	Pattern C	0.25	4	12	5, 2, 1	4, 4, 7	3 set apart 100 & 50 ft.
5	Pattern D Configuration 1	0.25	4	1 to 12	5	12	1 set
6	Pattern D Configuration 2	0.25	4	1 to 12	1	12	1 set
7	Pattern D Configuration 3	0.25, 0.50, 0.75	4	1 to 12	1	12	1 set
8	Pattern E	0.50	6	3	1, 1, 2, 5	6	1 set

In the following subsections, Section 4.4.1 analyzes the physical and attention-getting characteristics for each configuration. Section 4.4.2 comprehensively compares and evaluates all the configurations in terms of sound and vibration effectiveness, installation procedure, durability, and material cost. The final section examines the factors that influence the effectiveness of rumble strip design.

4.4.1 Results for Configuration Tests

4.4.1.1 Pattern B Configuration 1

This DRS configuration consists of a 12 ft. long 4 in. wide black rubber with five raised ridges spaced at 5 ft. (Figure 16). The strips were applied to the pavement using mixed epoxy (provided by TAPCO). For the right way direction, vehicle tires roll over the strips with a smooth transition of 20 degree edge. From the wrong way direction, the 90 degree edge of the strips may provide an alarming effect for the drivers.



Figure 17 Image of Pattern B Configuration 1

The sound and vibration data was analyzed in the R statistical analysis software. The maximum values observed while driving over the rumble strips relative to that observed over smooth pavement was the MOE used for both sound and vibration. When multiple observations of the same condition were made, the average of the maximum values was used. Table 12

displays the values of the sound and vibration measurements for Pattern B Configuration 1. Highlighted values are noticeable differences that are statistically significant at the 95% level. For the sound levels, both the right way and wrong way had 8 to 10 dBA sound increases than the baseline condition. The ANOVA test also indicated that the right way and wrong way sound were significantly different from the background noise in the speed of 10 to 20 mph. However, there was no significant difference for the right way and wrong way sound signals. The wrong way vibration was significantly different from the ambient condition for the speed of 20 and 25 mph. But there was no noticeable difference of right way and wrong way vibrations.

Table 12 Sound and vibration level of Pattern B Configuration 1

	Speed (mph)	10	15	20	25	35	45
Sound (dBA)	Ambient	53	55.5	57.7	62.2	64.2	67.3
	Right way	62.1	64.8	68.7	70.4	72.6	79
	Wrong way	61.8	63.8	68.9	70.7	72.5	77.8
	Right vs. Ambient	9.1	9.3	11	8.2	8.4	11.7
	Wrong vs. Ambient	8.8	8.3	11.2	8.5	8.3	10.5
	Wrong vs. Right	-0.3	-1.0	0.2	0.3	-0.1	-1.2
Vibration (g)	Ambient	1.014	1.022	1.026	1.03	1.025	1.061
	Right way	1.151	1.169	1.141	1.151	1.224	1.171
	Wrong way	1.171	1.135	1.152	1.18	1.181	1.234
	Right vs. Ambient	0.137	0.147	0.115	0.121	0.199	0.11
	Wrong vs. Ambient	0.157	0.113	0.126	0.15	0.156	0.173
	Wrong vs. Right	0.02	-0.034	0.011	0.029	-0.043	0.063

4.4.1.2 Pattern B Configuration 2

Pattern B Configuration 2 attempted to increase the wrong way stimuli by adding five more strips based on Pattern B Configuration 1. The white removable rumble strips are 0.4 in. wide, 0.25 in. thick and spaced at 1 ft. The sound and vibration results in Table 13 revealed that the sound level increased by 7.2 to 9.7 dBA under different speeds. The sound level increases were noticeable considering of the 6 dBA of human perception thresholds. However, the sound level difference between right way and wrong way was still inadequate as expected. Similarly, the

vehicle body vibration was observed at certain speeds for both directions. But in most cases, the differences of wrong way vs. right way were neither statistically significant nor noticeable.



Figure 18 Image of Pattern B Configuration 2

Table 13 Sound and vibration level of Pattern B Configuration 2

	Speed (mph)	25	35	45
Sound (dBA)	Ambient	64	64	67.1
	Right way	73.7	73.6	74.3
	Wrong way	73	73.4	74.8
	Right vs. Ambient	9.7	9.6	7.2
	Wrong vs. Ambient	9	9.4	7.7
	Wrong vs. Right	-0.7	-0.2	0.5
Vibration (g)	Ambient	1.03	1.025	1.061
	Right way	1.203	1.22	1.188
	Wrong way	1.267	1.192	1.191
	Right vs. Ambient	0.173	0.195	0.127
	Wrong vs. Ambient	0.237	0.167	0.13
	Wrong vs. Right	0.064	-0.028	0.003

4.4.1.3 Pattern B Configuration 3



Figure 19 Image of Pattern B Configuration 3

Pattern B Configuration 3 had multiple spacing based on Configuration 1. The wrong-way direction encountered a decreasing spacing from 5 ft. to 1 ft. Table 14 shows comparisons of in-vehicle sound levels relative to levels experienced on smooth pavement. The sound levels for both the right way and wrong way were from 10.8 to 13.7 dBA, noticeably greater than the ambient conditions. There were no in-vehicle sound comparisons that yielded right way and wrong way differences that were statistically significant or noticeable. For the vibration, the wrong way and right way were statistically significant under the speed of 25 mph and 45 mph. The vibration differences were respectively 0.01 g (0.10 m/s^2) and 0.032 g (0.31 m/s^2) for the speed of 25 mph and 45 mph, which was inadequate comparing with the vibration perception threshold (2.5 to 4.25 m/s^2). Figure 19 displays the sound and vibration signal profile under the speed of 45 mph. Based on the sound waveforms, it appears that the strips provided significantly higher sound than the baseline conditions in the DRS areas (from 50 ft. to 100 ft.). The vertical vibration fluctuated from 0.8 to 1.2 g due to the DRS installment. Generally, the sound signal for both the right way and wrong way had the similar curve trends, and the vibration in the wrong

way was a little bit greater than the right way direction. The right-way and wrong way stimuli did not have obvious difference as expected.

Table 14 Sound and vibration level of Pattern B Configuration 3

	Speed (mph)	10	15	20	25	35	45
Sound (dBA)	Ambient	52.3	54.6	57.7	64.4	64.2	67.3
	Right way	65	67.1	70.2	71.1	75.9	78
	Wrong way	64.4	68.3	68.5	71.2	74.1	77.5
	Right vs. Ambient	12.7	12.5	12.5	6.7	11.7	10.7
	Wrong vs. Ambient	12.1	13.7	10.8	6.8	9.9	10.2
	Wrong vs. Right	-0.6	1.2	-1.7	0.1	-1.8	-0.5
Vibration (g)	Ambient	1.014	1.022	1.026	1.03	1.025	1.061
	Right way	1.227	1.213	1.206	1.209	1.202	1.12
	Wrong way	1.192	1.221	1.211	1.219	1.155	1.152
	Right vs. Ambient	0.213	0.191	0.18	0.179	0.177	0.059
	Wrong vs. Ambient	0.178	0.199	0.185	0.189	0.13	0.091
	Wrong vs. Right	-0.035	0.008	0.005	0.01	-0.047	0.032

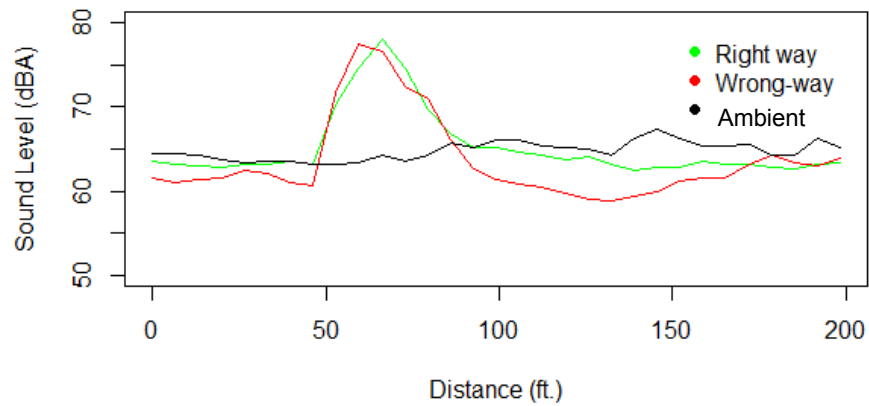

(a)

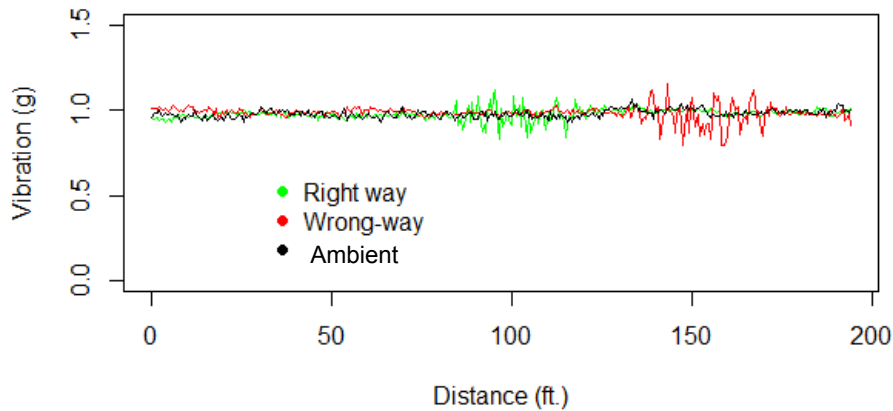

(b)

Figure 20 Signal profile for Pattern B Configuration 3 under 45 mph (a: sound level; b: vibration)

4.4.1.4 Pattern C

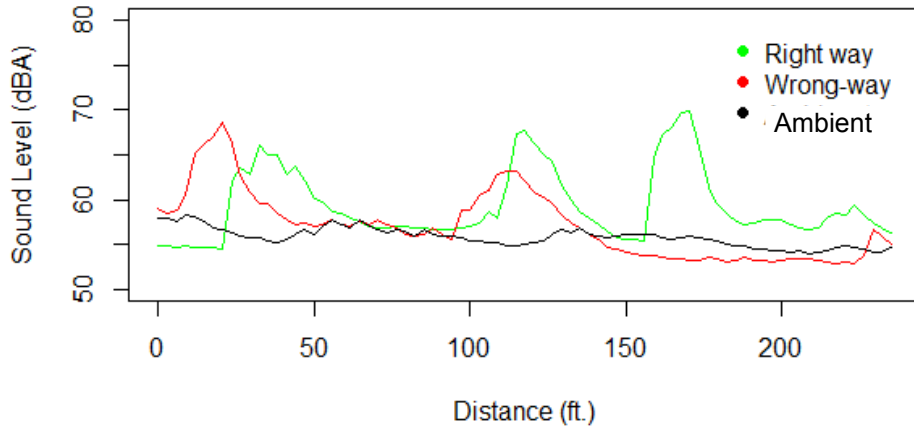

Figure 21 Image of Pattern C

Figure 20 is a generalized diagram of Pattern C that had multiple spacing among strips. This pattern contained three groups with 100 ft. and 50 ft. between groups. Each group contained four, four, and seven rumble strips, spaced 5 ft., 2 ft. and 1 ft. edge to edge. These strips stretched across the entire width of the lane with the length of 10 ft. Comparisons that yielded statistically significant differences are highlighted in Table 15. For the speed of 10 to 20 mph, the right way sound level was significantly greater than the wrong way direction based on the ANOVA results. Particularly in 10 mph, the difference of 14.3 dBA was perceivable for driving in different directions. The vibration data also revealed some differences in 10 to 25 mph. Figure 21 describes the sound and vibration signals. For the sound signals, when the vehicle drove along the right way, the peak values showed an increasing trend for each group of strips. The wrong way curve showed a reverse trend. This phenomenon can also be observed from the vibration profile. From the left to the right, the vibration signal became denser for each group of strips with verified spacing and number of strips.

Table 15 Sound and vibration level of Pattern C

	Speed (mph)	10	15	20	25	35	45
Sound (dBA)	Ambient	52.3	54.6	57.7	61	64.2	67.3
	Right way	76.5	66.1	69.8	69.1	74.6	80.1
	Wrong way	62.2	65.9	68.6	70.9	73.7	78.8
	Right vs. Ambient	24.2	11.5	10.9	8.1	10.4	12.8
	Wrong vs. Ambient	9.9	11.3	12.1	9.9	9.5	11.5
	Wrong vs. Right	-14.3	-0.2	-1.2	1.8	-0.9	-1.3
Vibration (g)	Ambient	1.025	1.022	1.03	1.03	1.034	1.061
	Right way	1.123	1.159	1.179	1.157	1.217	1.152
	Wrong way	1.122	1.12	1.156	1.139	1.209	1.123
	Right vs. Ambient	0.098	0.137	0.149	0.127	0.183	0.091
	Wrong vs. Ambient	0.097	0.098	0.126	0.109	0.175	0.062
	Wrong vs. Right	-0.001	-0.039	-0.023	-0.018	-0.008	-0.029



(a)

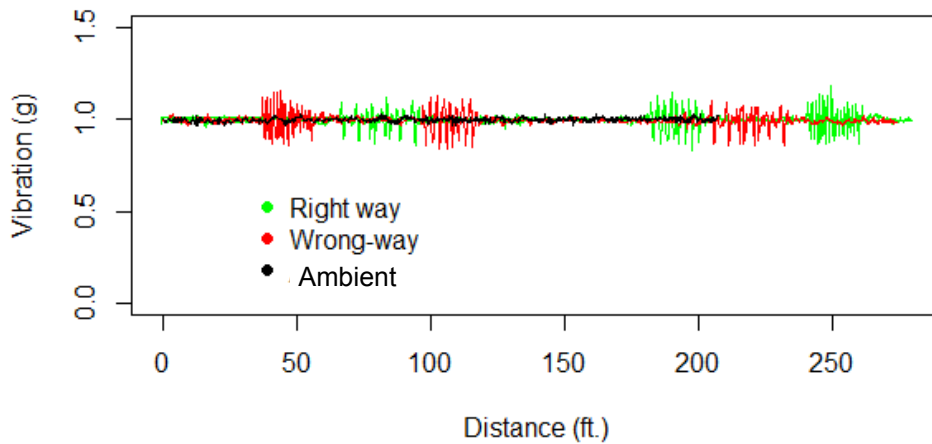

(b)

Figure 22 Sound and vibration signal profile for Pattern C under 20 mph
(a: sound level; b: vibration)

4.4.1.5 Pattern D Configuration 1



Figure 23 Image of Pattern D Configuration 1 (left: daytime, right: nighttime)

Pattern D constituted a lane direction arrow using the ATM removable rumble strips. The length of the strips decreased from 12 ft. to 1 ft. with the spacing of 5 ft. among the strips. The sound and vibration data of 25 mph, 35 mph and 45 mph were collected in the first field testing period. The results in Table 16 indicated 7.2 to 11.3 dBA sound level increases. The vibrations in both right and wrong way directions were significantly different from the ambient condition. However, no big difference was observed for the right way and wrong way sound and vibration levels.

Table 16 Sound and vibration level of Pattern D Configuration 1

	Speed (mph)	25	35	45
Sound (dBA)	Ambient	65.1	64.2	67.3
	Right way	76.4	76.5	77.3
	Wrong way	77.5	75.4	74.5
	Right vs. Ambient	11.3	12.3	10
	Wrong vs. Ambient	12.4	11.2	7.2
	Wrong vs. Right	1.1	-1.1	-2.8
Vibration (g)	Ambient	1.03	1.025	1.061
	Right way	1.228	1.17	1.182
	Wrong way	1.215	1.181	1.111
	Right vs. Ambient	0.198	0.145	0.121
	Wrong vs. Ambient	0.185	0.156	0.05
	Wrong vs. Right	-0.013	0.011	-0.071

4.4.1.6 Pattern D Configuration 2

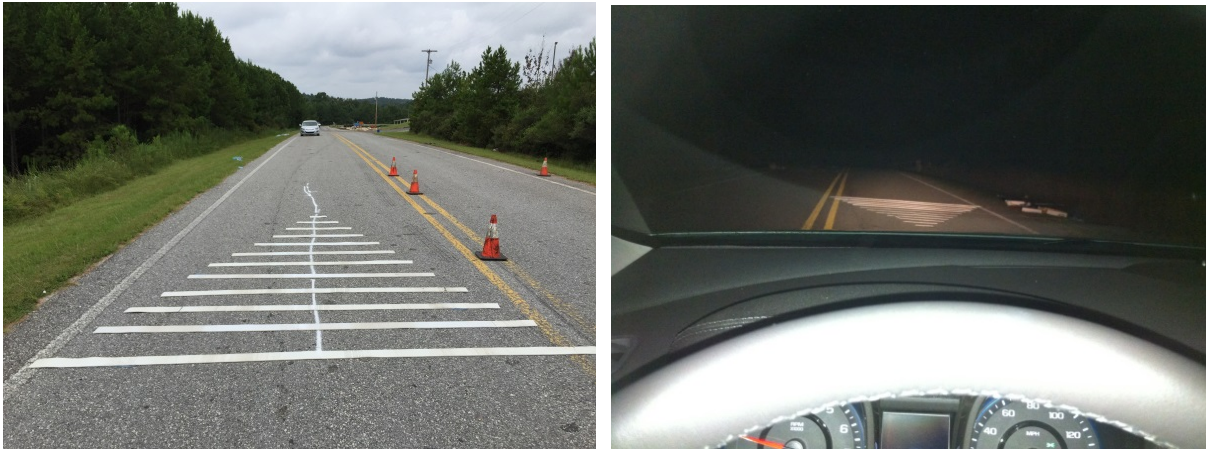
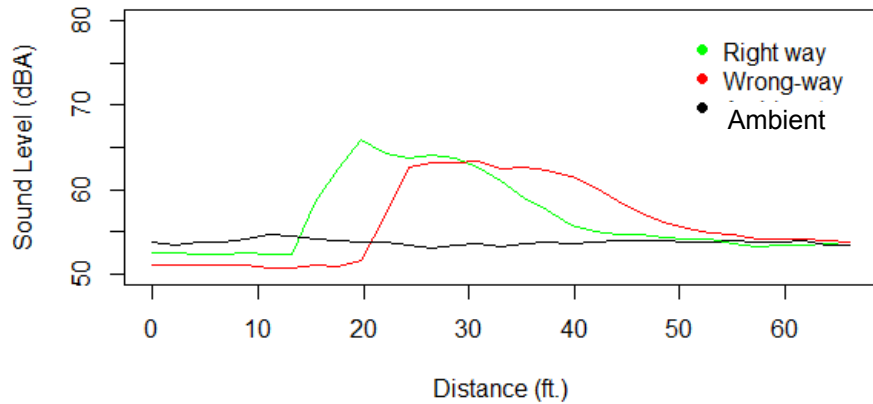

Figure 24 Image of Pattern D Configuration 2 (left: daytime, right: nighttime)

Figure 23 shows the DRS direction arrow in both day and night conditions. During the nighttime, the arrow also had good visibility for the wrong way drivers. Comparing with Configuration 1, Configuration 2 verified the spacing among the strips to be 1 ft., the other parameters (length, width, number of strips) remained the same as Configuration 1. Table 17 lists the sound and vibration analysis results. It was observed that the sound increase ranged from 7.5 to 12.1 dBA, and both the right way and wrong way sound increases were significantly greater than the background noise. However, the sound level was not significantly different for the right way and wrong way directions. The vibration also showed no significant difference of right and wrong way stimuli in most of the cases. Figure 24 describes the sound and vibration signals with the right way and wrong way having similar curve profiles. At 20 mph, the sound level of the DRS section was within the range of 55 mph to 65 mph along the road. Both the right way and wrong way signals show the similar waveform. The right-way and wrong-way vibration profiles also had similar shapes.

Table 17 Sound and vibration level of Pattern D Configuration 2

	Speed (mph)	10	15	20	25	35	45
Sound (dBA)	Ambient	52.3	54.6	57.7	61	64.2	67.3
	Right way	64.4	65.9	67.3	69.1	74.6	79.2
	Wrong way	64	63.4	68.2	68.5	74.2	75.3
	Right vs. Ambient	12.1	11.3	9.6	8.1	10.4	11.9
	Wrong vs. Ambient	11.7	8.8	10.5	7.5	10	8
	Wrong vs. Right	-0.4	-2.5	0.9	-0.6	-0.4	-3.9
Vibration (g)	Ambient	1.014	1.022	1.026	1.03	1.025	1.061
	Right way	1.123	1.114	1.124	1.123	1.153	1.153
	Wrong way	1.133	1.118	1.122	1.157	1.223	1.142
	Right vs. Ambient	0.109	0.092	0.098	0.093	0.128	0.092
	Wrong vs. Ambient	0.119	0.096	0.096	0.127	0.198	0.081
	Wrong vs. Right	0.01	0.004	-0.002	0.034	0.07	-0.011



(a)

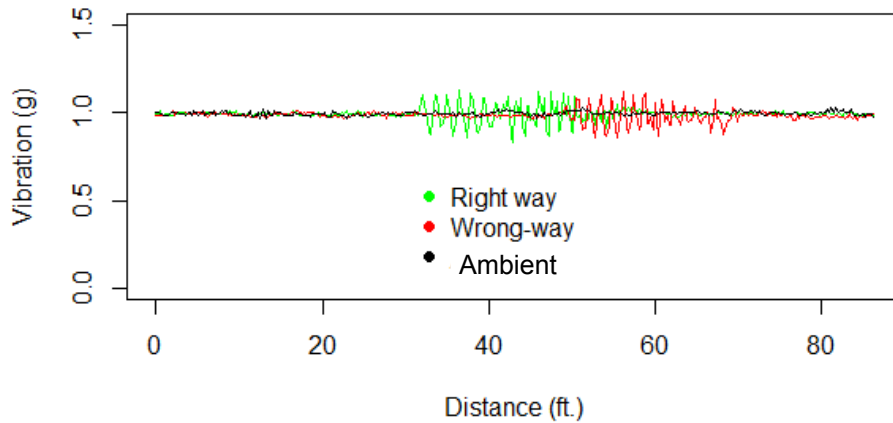

(b)

Figure 25 Sound and vibration signal profile for Pattern D Configuration 2 under 20 mph
(a: sound level; b: vibration)

4.4.1.7 Pattern D Configuration 3



Figure 26 Image of Pattern D Configuration 3

Pattern D Configuration 3 featured multiple thicknesses of strips. The first seven strips (length from 1 ft. to 7 ft.) remained the single thickness of 0.25 in. The 8th to 10th strips (length of 8 ft. 9 ft. 10 ft.) had the doubled thickness by overlapping two layers of strips. The last two strips (length of 11 ft. and 12 ft.) had the thickness of 0.75 ft. with three layers of strips. Table 18 details the sound and vibration data. The sound level increases ranged from 8.9 to 19.2 dBA under different testing speeds. The sound level increase was relatively greater than other tested configurations. The detailed comparison is presented in Section 4.4.2. The sound level has significant differences for the right and wrong directions at the speed of 25 mph, the vibration has significant differences for both directions at the speed of 45 mph. Figure 26 displays the sound signal for the speed of 25 mph and the vibration curve of 45 mph. The slight difference of right way and wrong way signals can be observed from the profiles.

According to the driver perceptions, the Pattern D Configuration 3 was the only pattern that the driver could feel different sounds and vibrations between the wrong way and the right way in

the field test. Higher sound and denser vehicle body vibrations were experienced for driving in the wrong-way direction.

Table 18 Sound and vibration level of Pattern D Configuration 3

	Speed (mph)	10	15	20	25	35	45
Sound (dBA)	Ambient	52.3	54.6	57.7	64.4	64.2	67.3
	Right way	70.4	73.6	72.2	73.3	78	79.6
	Wrong way	69.4	73.8	73.8	73.4	78.4	80
	Right vs. Ambient	18.1	19	14.5	8.9	13.8	12.3
	Wrong vs. Ambient	17.1	19.2	16.1	9	14.2	12.7
	Wrong vs. Right	-1	0.2	1.6	0.1	0.4	0.4
Vibration (g)	Ambient	1.014	1.022	1.026	1.03	1.025	1.024
	Right way	1.309	1.307	1.225	1.199	1.303	1.181
	Wrong way	1.385	1.358	1.255	1.217	1.28	1.22
	Right vs. Ambient	0.295	0.285	0.199	0.169	0.278	0.157
	Wrong vs. Ambient	0.371	0.336	0.229	0.187	0.255	0.196
	Wrong vs. Right	0.076	0.051	0.03	0.018	-0.023	0.039

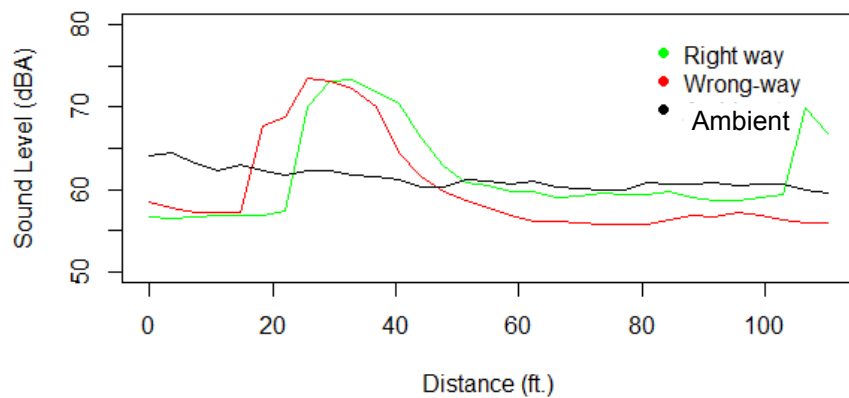

(a)

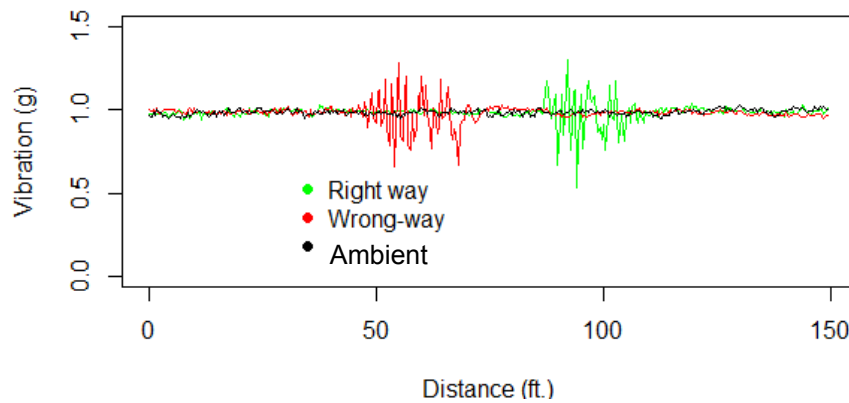

(b)

Figure 27 Sound and vibration signal profile for Pattern D Configuration 3 (a: 25 mph sound level; b: 45 mph vibration)

4.4.1.8 Pattern E

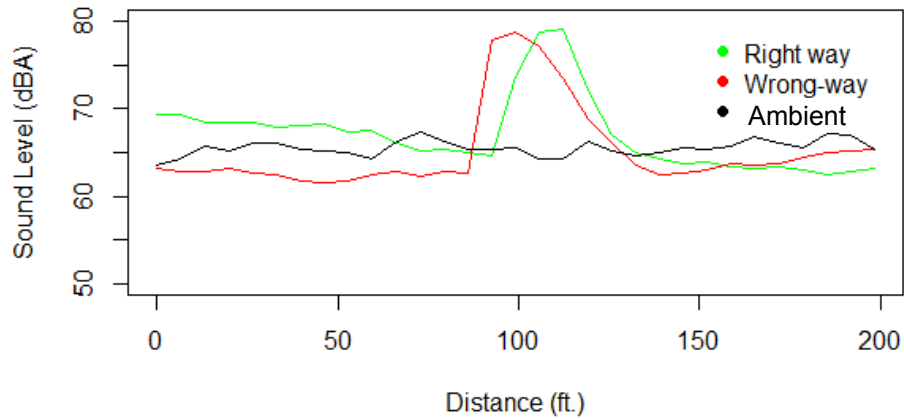

Figure 28 Image of Pattern E (left: daytime, right: nighttime)

Pattern E was a simple triangle design provided by the Peek Pavement Marking, LLC. The raised strips were installed by the particular machine of the vendor. The five strips were spaced at 1 ft., 1 ft., 2 ft., and 5 ft. to increase the signals for the wrong way direction. The strips only cover the width of vehicle wheel path in the field test to save time of installation. If the test results show positive effects, this configuration will be compared with the one that covered the whole lane width in a later study. Table 19 lists the sound and vibration calculation results. The sound increase was 11 to 17.2 dBA for different speeds, which were considerable increases based on the background noises. However, the right way and wrong way increases were not statistically significant according to the ANOVA test results. The vibration increase was 0.131 to 0.319 g more than the baseline conditions, which were comparable to the vibration perception threshold of 0.26 to 0.43 g. For the right way and wrong way comparison, the vibration was found to be different at the speed of 45 mph. The difference of the maximum vibration was 0.02 g, relatively inadequate to create different vibration perceptions. Figure 28 describes the sound and vibration curves for the speed of 45 mph. The curve trend was generally the same for both right way and wrong way directions.

Table 19 Sound and vibration level of Pattern E

	Speed (mph)	10	15	20	25	35	45
Sound (dBA)	Ambient	52.5	55.5	57.7	61	64.2	67.3
	Right way	65	66.5	72.4	78.2	77.3	79
	Wrong way	69.1	69.4	72.4	74.6	76.9	78.8
	Right vs. Ambient	12.5	11	14.7	17.2	13.1	11.7
	Wrong vs. Ambient	16.6	13.9	14.7	13.6	12.7	11.5
	Wrong vs. Right	4.1	2.9	0	-3.6	-0.4	-0.2
Vibration (g)	Ambient	1.014	1.022	1.026	1.03	1.025	1.061
	Right way	1.333	1.309	1.327	1.257	1.23	1.212
	Wrong way	1.267	1.241	1.309	1.272	1.305	1.192
	Right vs. Ambient	0.319	0.287	0.301	0.227	0.205	0.131
	Wrong vs. Ambient	0.253	0.219	0.283	0.242	0.28	0.151
	Wrong vs. Right	-0.066	-0.068	-0.018	0.015	0.075	0.02



(a)

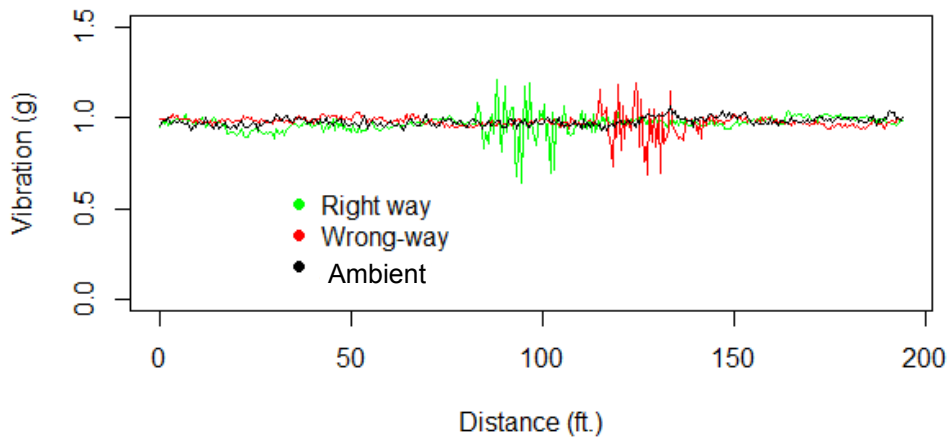

(b)

Figure 29 Sound and vibration signal profile for Pattern E under 45 mph
(a: sound level; b: vibration)

4.4.2 Comprehensive Comparisons of DRS Configurations

One primary goal of the field test is to provide a detailed and thorough comparison of the proposed DRS patterns. The specific objectives are to determine the optimal configurations with respect to the following parameters: wrong way sound and vibration inside the vehicle; different signals for the right and wrong way directions; material costs; durability. The installation and removal time, damage done to the pavement during removal was also provided in the evaluation. For the real application in the future, more factors will be considered, such as the total cost including materials, labors, and installation; the durability and maintenance for the permanent implementation.

4.4.2.1 *Wrong-way signal analysis*

Figure 29 shows the wrong-way sound level and vertical vibration for different patterns under different speed categories. As per the maximum sound stimuli generated, the ambient sound level was 53 dBA to 67.3 dBA for the speed range of 10 mph to 45 mph. The tested patterns created 7.2 to 16.6 dBA greater sound levels than the ambient condition. The sound level increase was adequate to alert drivers according to the typical rise of 6 to 10 dBA threshold of sound perception and comparable to 14 dBA increase of the TRS on Highway 280. Among these patterns, Pattern D Configuration 3, Pattern E, Pattern C, and Pattern B Configuration 3 produced higher wrong-way sound levels than other patterns. The maximum vertical vibration of an ambient condition was 1.01 to 1.06 g under the speed of 10 mph to 45 mph. The vibration generated by the tested patterns ranged from 1.1 to 1.4 g. Pattern D Configuration 3 produced the highest vibration increase (0.26 g (2.57 m/s²)) compared to the baseline condition, Pattern E created a 0.23 g (2.30 m/s²) vibration change, Pattern B Configuration 3 had a 0.16 g (1.59 m/s²) raise over the baseline, and Pattern C had a 0.11 g (1.09 m/s²) increase. Therefore, Pattern D Configuration 3 and Pattern E generated comparable vibration changes with the threshold of vibration perception (2.5 to the 4.25 m/s²) from previous studies (Lank and Steinauer 2011, NCHRP 2007).

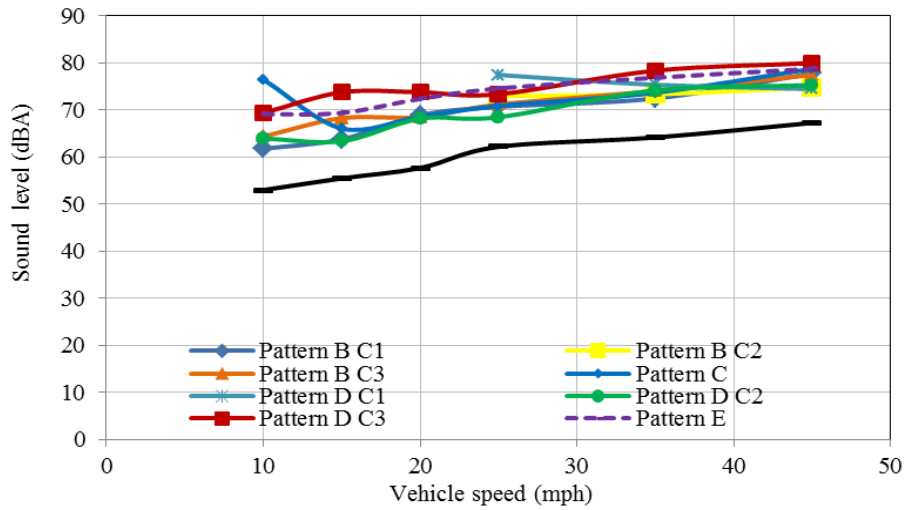

(a)

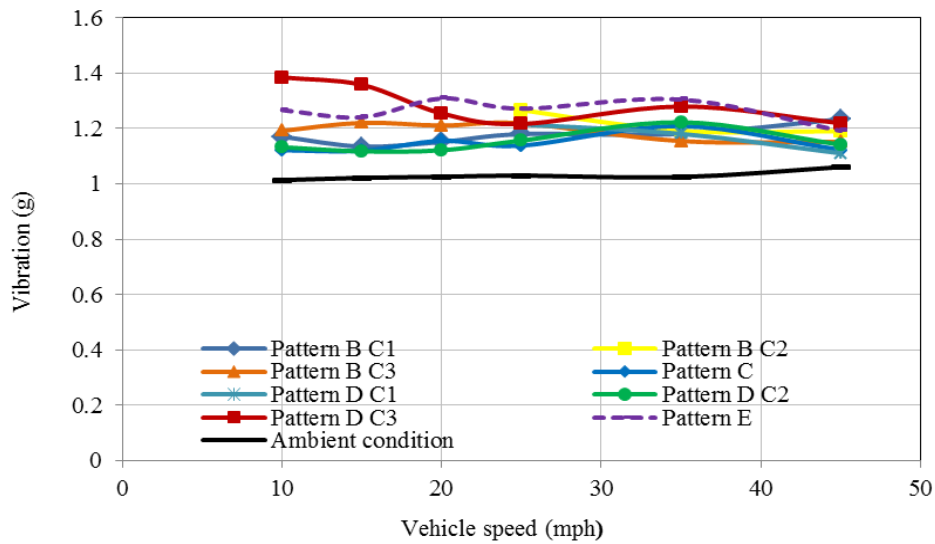

(b)

Figure 30 Sound and vibration level for the wrong-way direction (a: maximum A-weighted sound level; b: maximum vertical vibration)

4.2.2.2 Right-way and wrong-way effect comparison

Tables 20 and 21 present the outcomes of the ANOVA and *t*-test. The highlighted results show the statistically significant differences of the two data sets. The results provided evidence that Pattern C generated significant different sound and vibration signals for the right way and wrong way directions at the speed of 10 to 25 mph. Pattern B Configuration 3 showed statistically significant difference in the vibration at 25 and 45 mph. Pattern E showed a

statistical vibration difference at 45 mph. Besides, the statistical differences were observed for Pattern D Configuration 2, Pattern D Configuration 3, Pattern B Configuration 1 and Configuration 2 under certain speed ranges.

Table 20 Statistical test results of sound level comparison

Pattern	Test	10 mph	15 mph	20 mph	25 mph	35 mph	45 mph
Pattern B Configuration 1	<i>t</i> -test	0.7629	0.5837	0.7393	0.905	0.5895	0.9514
	ANOVA	0.7628	0.5836	0.7393	0.9050	0.5895	0.9514
Pattern B Configuration 2	<i>t</i> -test	-	-	-	0.969	0.7956	0.4834
Pattern B Configuration 3	<i>t</i> -test	0.4034	0.5331	0.7912	0.763	0.07198	0.1786
	ANOVA	0.4034	0.5331	0.7912	0.7630	0.0719	0.1783
Pattern C	<i>t</i> -test	0.0035	0.00095	0.00037	0.00037	0.071	0.511
	ANOVA	0.0042	0.0010	0.0004	0.1746	0.0712	0.5122
Pattern D Configuration 1	<i>t</i> -test	-	-	-	0.8548	0.6821	0.05645
Pattern D Configuration 2	<i>t</i> -test	0.9655	0.6338	0.6338	0.9696	0.5527	0.03221
	ANOVA	0.9655	0.6338	0.5236	0.9696	0.5527	0.0268
Pattern D Configuration 3	<i>t</i> -test	0.4925	0.7364	0.6256	0.2301	0.06954	0.3395
	ANOVA	0.4925	0.7364	0.6255	0.0433	0.1127	0.3243
Pattern E	<i>t</i> -test	0.9034	0.8384	0.5754	0.7072	0.6646	0.1062
	ANOVA	0.9034	0.2092	0.5754	0.7072	0.6646	0.1061

Table 21 Statistical test results of vibration comparison

Pattern	Test	10 mph	15 mph	20 mph	25 mph	35 mph	45 mph
Pattern B Configuration 1	<i>t</i> -test	0.6304	0.6975	0.09159	0.06965	0.6316	0.00068
	ANOVA	0.6304	0.6976	0.0916	0.0697	0.6309	0.0006
Pattern B Configuration 2	<i>t</i> -test	-	-	-	0.4306	0.0339	0.0050
	ANOVA	-	-	-	0.4296	0.0637	0.0050
Pattern B Configuration 3	<i>t</i> -test	0.6805	0.06969	0.6839	0.02324	0.5813	0.04124
	ANOVA	0.6804	0.0697	0.6839	0.0232	0.5813	0.0413
Pattern C	<i>t</i> -test	0.0000	0.0000	0.009349	0.000164	0.07445	0.8249
	ANOVA	0.0000	0.0000	0.0093	0.0001	0.0725	0.8269
Pattern D Configuration 1	<i>t</i> -test	-	-	-	0.7311	0.9351	0.1508
	ANOVA	-	-	-	0.7311	0.9351	0.1507
Pattern D Configuration 2	<i>t</i> -test	0.3785	0.4818	0.0012	0.5039	0.763	0.6898
	ANOVA	0.3785	0.4818	0.0012	0.5039	0.7588	0.6900
Pattern D Configuration 3	<i>t</i> -test	0.6203	0.6077	0.141	0.3577	0.7251	0.7251
	ANOVA	0.6203	0.6076	0.1410	0.3577	0.7251	0.0263
Pattern E	<i>t</i> -test	0.7382	0.9057	0.258	0.266	0.73	0.01935
	ANOVA	0.7382	0.9060	0.2580	0.2662	0.7300	0.0183



Figure 31 Sound profile for right way and wrong way directions

To understand the exact difference in total amount of sounds caused by DRS between right way and wrong way, the study used the areas above the ambient condition to measure the amount of increased sound. Figure 30 shows the sound profile of both directions, with the areas above the ambient condition was calculated to compare the sound stimuli. Table 22 illustrates the results of the computed area. It was found that pattern C had a significant difference in the speed category of 10 mph to 20 mph, and the sound level difference was from 67.33 to 446.29 dBA·ft. However, the wrong-way sound level was more intensified than the right-way sound. Therefore, the wrong-way and right way directions can be reversed in further implementation and tests. For Pattern E, the wrong-way sound level was significantly greater than the right way direction in 20 mph and 45 mph, and the difference was 198.16 dBA·ft. and 248.72 dBA·ft. respectively. Pattern B Configuration 1, Pattern B Configuration 2 also had the wrong-way sound significantly greater than the right-way sound level under certain speed ranges.

Table 22 Total amount of sound increased by DRS (dBA·ft.)

Pattern	10 mph	15 mph	20 mph	25 mph	35 mph	45 mph
Pattern B Configuration 1	6.321	16.5375	10.29	63.5775	-34.4715	-102.5325
Pattern B Configuration 2	-	-	-	-88.2	151.7775	291.06
Pattern B Configuration 3	-33.369	64.386	6.468	-5.88	-62.769	-5.6595
Pattern C	-67.326	-210.357	-446.292	-29.7675	-29.3265	160.7445
Pattern D Configuration 1	-	-	-	-3.675	16.464	-379.0395
Pattern D Configuration 2	2.205	1.1025	33.516	26.0925	26.2395	-85.3335
Pattern D Configuration 3	-44.1	-19.845	54.978	-2.646	24.1815	-70.119
Pattern E	12.201	-7.056	198.156	-34.104	-12.8625	248.724

4.4.2.3 Cost and durability

In order to provide a more detailed and thorough evaluation of the DRS configurations, a comparison of the costs, installation, and removal associated with each of the strips is essential. The cost here only refers to the material costs. Other costs like labor and maintenance will be included in the final design guidelines. Table 23 summarizes the DRS characteristics in term of the cost, installation and removal time based on the field test; the durability and damage to pavement were based on field observations.

Pattern B Configuration 1 was constituted by the TAPCO rumble strips. The strips came in 23.5 in.×3.5 in.×0.5 in. In total, 30 strips were ordered from the vendor to deploy the Configuration 1 with five 12 ft. strips rows. The cost of \$401.30 included expenses for both rumble strips and the mixed epoxy for installation. Pattern B Configuration 3 had the same cost because it used the same amount of strips and mixed epoxy. The Configuration 2 needed one extra roll of ATM removable rumble strips (\$208.95 per roll) to add five more strips based on Configuration 1. Pattern C, Pattern D Configuration 2, and Pattern D Configuration 3 can be respectively deployed by using three rolls of ATM removable rumble strips. The cost was around \$630.00 for each of these configurations.

Table 23 Comparison of DRS characteristics

Pattern	Cost (\$)	Installation time	Removal time	Durability	Damage to pavement
Pattern B Configuration 1	401.30	3 h	1 h	Medium	Some
Pattern B Configuration 2	610.25	3.5 h	1 h	Medium	Some
Pattern B Configuration 3	401.30	3 h	1 h	2nd	Some
Pattern C	626.85	1 h	10 min	Shortest	No
Pattern D Configuration 1	417.90	30 min	10 min	Shortest	No
Pattern D Configuration 2	626.85	30 min	10 min	Shortest	No
Pattern D Configuration 3	626.85	40 min	10 min	Shortest	No
Pattern E	NA	4 h	2 h	Longest	Some

Note: the installation, removal and damage to the pavement were provided based on testing observation under current stage. More factors can be considered for further permanent installation in real exit ramps.

The installation process was similar for all the configurations. The assumption is two workers for one group. The locations where the strips were to be placed were determined using a tape measure and marking with masking tape. The dry pavement was swept with a push broom. Pattern B needed installation by inserting the strips onto the mixed epoxy. For Pattern C and Pattern D, the removable rumble strips rolls (50 ft.) had to be cut into the desired length prior to installation. The need for the double thickness strips increased the installation time by 10 more minutes, compared to an installation using a single thickness. The Pattern E required particular more time and effort than other types of DRS.

To remove either type of the rumble strips, a corner was pried free with a crow bar or other similar tool, and the strips were then pulled by hand until they were entirely removed. All strips came up in one piece. The process required two workers approximately 10 minutes to remove a group of orange rumble strips. The removal of Pattern E required specific equipment and more time to take away the strips. The removal of Pattern B and Pattern E had a small amount of damage to the pavement.

Determining the durability of the removable rumble strips was done by simply observing the amount of damage the strips had incurred over the length of their deployment.

4.4.2.4 Summary

Table 24 shows a qualitative comparison of eight DRS configurations. The properties were scored by 1 to 5 scales representing poor to excellent. For the sound and vibration performance, Pattern C, Pattern D Configuration 3, and Pattern E were valued relatively higher than other patterns. The configurations constituted by the removable rumble strips cost a little bit more than the TAPCO rumble strips considering five sets of strips. The installation and removal of Pattern C and Pattern D were easier than Pattern B and Pattern E but had relatively short durability. Pattern D and Pattern E were featured with good visual attentiveness. With the comprehensive comparison, Pattern C and Pattern D Configuration 3 were finally recommended for further optimization and verification. Pattern E had relatively low rating for installation and removal but good attention-getting effects and visual attentiveness, which was also recommended for further implementation.

Table 24 Comparison of DRS characteristics

Pattern	Sound	Vibration	Cost (\$)	Installation time	Removal time	Visual attentiveness	Total Score
Pattern B Configuration 1	3	3	4	2	2	3	17
Pattern B Configuration 2	3	3	3	2	2	3	16
Pattern B Configuration 3	3	4	4	2	2	3	18
Pattern C	5	5	3	4	5	3	25
Pattern D Configuration 1	3	3	3	4	5	5	23
Pattern D Configuration 2	3	3	3	4	5	5	23
Pattern D Configuration 3	4	5	3	4	5	5	26
Pattern E	5	4	3	1	1	4	18

Note: 5—Excellent; 4—Very good; 3—Good; 2—Fair; 1—poor.

4.4.3 Factors affecting DRS sound and vibration effects

The testing results revealed that some design characteristics influence the effectiveness of a DRS to alert motorists. The specific characteristics include vehicle speed, thickness of the strips, and the spacing of strips.

4.4.3.1 Vehicle speed

The relationships between vehicle speed and DRS sound level and vibration can be observed in Figure 29. Generally, the sound level saw increases for all the tested patterns with the speed increase. Taking Pattern D Configuration 3 as an example (Figure 31), the wrong-way sound level increased from 55 to 65 dBA with the speed increased from 10 mph to 45 mph. The positive relation of sound level and vehicle speed was also proved in the initial field test results. In sound vs. vehicle speeds of the initial field test (Figure 9), the rising trend in sound and vibration was observed for both ambient and TRS conditions.

It can also be observed that for most of the tested patterns, the vibration had small decrease with the raising of speed. The vibration of Pattern D Configuration 3 decreased from 1.39 g to 1.22 g. Other patterns followed a similar trend. Another fact is that, some designed patterns were effective on certain speeds but not for other speeds. For example, Pattern C has right-way and wrong-way differences from the speed of 10 mph to 25 mph. At 45 mph, the difference of right-way and wrong-way was noticeable for Pattern E. The Tukey's Honest Significance Test results also provide evidence that the sound level of all the tested patterns had a significant difference under different vehicle speeds (Appendix B).

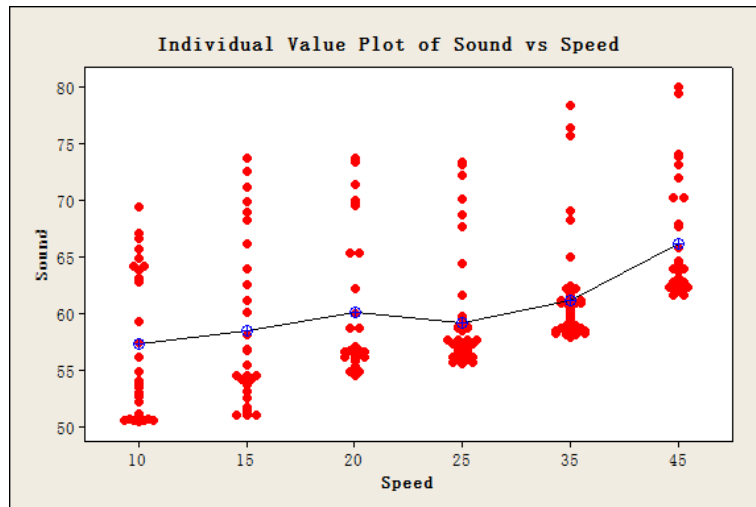

(a)

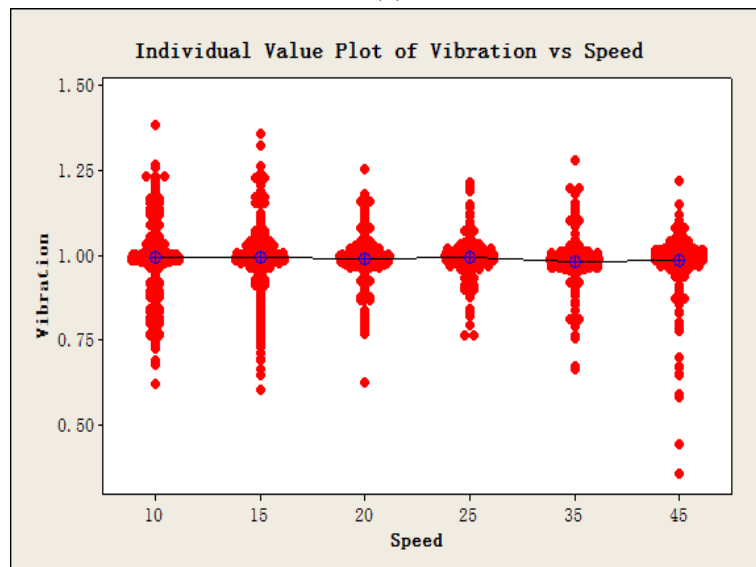

(b)

Figure 32 Sound and vibration changes vs. speed for wrong-way direction of Pattern D Configuration 3 (a: sound level; b: vibration)

4.4.3.2 Strip thickness

The thickness of strips is an important factor affecting the sound and vibration effects. As the height of the strip increases, the sound and vibration should also increase. For Pattern D Configuration 3, the first seven strips (length from 1 ft. to 7 ft.) remained the single thickness of 0.25 in. The 8th to 10th strips (length of 8 ft. 9 ft. 10 ft.) had the doubled thickness by overlapping two layers of strips. The last two strips had the thickness of 0.75 ft. with three layers

of strips. Figure 29 shows that both the sound level and vibration for Pattern D Configuration 3 were higher than Pattern D Configuration 2. Table 25 compares the sound and vibration of Pattern D Configuration 2 and Configuration 3. The sound level generated for Configuration 3 was 4.2 to 10.4 dBA greater than Configuration 2, because of the increases of the thickness. The difference of vibration was also from 0.078 g to 0.252 g (0.76 m/s² to 2.50 m/s²). Both the sound and vibration changes were noticeable according to the human perception threshold.

Table 25 Wrong-way signal comparison of Pattern D Configuration 2 and 3

Index	Pattern	10 mph	15 mph	20 mph	25 mph	35 mph	45 mph
Sound (dBA)	Pattern D C2	64	63.4	68.2	68.5	74.2	75.3
	Pattern D C3	69.4	73.8	73.8	73.4	78.4	80
	Difference	5.4	10.4	5.6	4.9	4.2	4.7
Vibration (g)	Pattern D C2	1.133	1.118	1.122	1.157	1.223	1.142
	Pattern D C3	1.385	1.358	1.255	1.217	1.28	1.22
	Difference	0.252	0.24	0.133	0.06	0.057	0.078

4.4.3.3 Strip spacing

The sound and vibration for the configurations with multiple spacing did vary from the standard configuration. For Pattern C, the spacing of each set of strips was 5 ft., 2 ft. and 1 ft. The configuration showed significant and noticeable increases in both sound and vibration. Figure 32 describes the sound and vibration profile for different speed ranges. From left to the right, the spacing of the strips changed from 5 ft. to 2 ft. and then to 1 ft. Sound and vibration increased with the descending spacing under each of the speed categories.

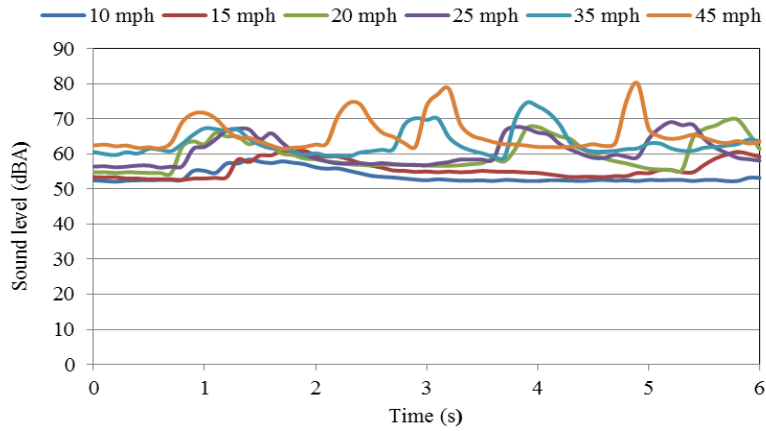

(a)

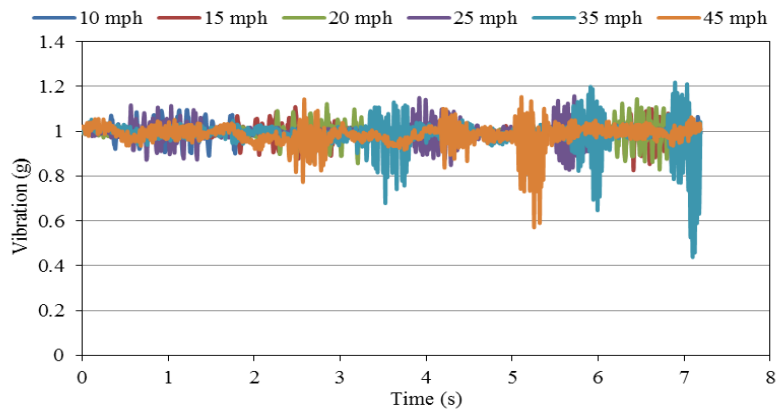

(b)

Figure 33 Sound and vibration signals of Pattern C under different speed

In Pattern B, Configuration 1 was spaced at 5 ft. and Configuration 3 was spaced at 5 ft. to 1 ft. from the first strip to the sixth strip. Table 26 provides evidence that the sound and vibration had certain increases for Configuration 3 (averaging 1.53 dBA for sound and 0.03 g for vibration).

Table 26 Wrong-way signal comparison of Pattern B Configurations 1 and 3

Index	Pattern	10 mph	15 mph	20 mph	25 mph	35 mph	45 mph
Sound	Pattern B C1	61.8	63.8	68.9	70.7	72.5	77.8
	Pattern B C3	64.4	68.3	68.5	71.2	74.1	77.5
	Difference	2.6	4.5	-0.4	0.5	1.6	-0.3
Vibration	Pattern B C1	1.171	1.135	1.152	1.18	1.181	1.234
	Pattern B C3	1.192	1.221	1.211	1.219	1.155	1.152
	Difference	0.021	0.086	0.059	0.039	-0.026	-0.082

CHAPTER 5

CONCLUSIONS

The objective of this study was to determine if the DRS can be used as a warning system to deter wrong-way freeway entries. To accomplish this objective, five conceptual designs were proposed and evaluated by extensive field tests. The initial field data were collected and analyzed to evaluate the effectiveness of the presence of TRS on driver behavior and to determine the human perceptibility to sound and vibrations. A national survey was initiated to collect the views on DRS designs from transportation professionals. The field test was then performed to verify the effectiveness of the proposed DRS patterns. The conclusions from this research can be summarized as follows:

(1) The tested TRS strips produced a recognizable amount of interior noise and a moderate amount of vibration to affect driver behavior. For sound levels at different speeds, the A-weighted volume in the area of the TRS was on average 14 dBA above the baseline noise level without TRS, and the vibration signal along the vertical axis resulted in an average difference of 0.68 m/s^2 when compared with smooth pavement. The tested TRS showed positive effects on speed reduction. During both the daytime and nighttime, drivers utilized lower speeds at the intersections compared with the initial upstream speed. In this experiment, 6 dBA was considered as an appropriate threshold for sound level study, and 0.26 to 0.43 g (2.5 to the 4.25 m/s^2) vibration change was taken as the threshold of perceptibility of vibration.

(2) The national survey suggested that 84.62% of the participants considered the DRS were likely to act as a warning system on exit ramps to mitigate the WWD. The designed Pattern B (the raised wedge design of DRS), Pattern A (overlapped removable rumble strips as DRS),

Pattern D (triangle shaped DRS with decreasing length of strips), and Pattern C (DRS with verified number of strips and spacing) were rated as the most feasible conceptual designs.

(3) In the field test, Pattern C, Pattern D Configuration 3, and Pattern E were recommended for further optimization based on their attention-getting effects, material cost, installation and removal time, durability, and visual attentiveness. All the tested patterns generated adequate sound changes in the wrong-way direction to alert drivers (7.2 to 16.6 dBA increases over the ambient condition). Pattern D Configuration 3 and Pattern E produced comparable vibration changes with vibration perception threshold. The statistical test provided evidence that Pattern C generated significantly different sound and vibration signals for the right-way and wrong-way directions in the speed of 10 to 25 mph. Pattern E shows statistical sound differences at 20 mph and 45 mph and a vibration difference at 45 mph.

(4) The field test results revealed some crucial factors related to the effectiveness of DRS. Vehicle speed affected the change in sound inside the vehicle. The sound level increased for all the tested patterns when the vehicle speed increased. The thickness of strips directly associated with the maximum displacement of the tires, and the sound and vibration increased with the raised thickness of the strips. As the spacing increases, sound and vibration decreased because the frequency of the tire displacement decreased.

The next step of the study was optimizing the selected patterns, including Pattern C, Pattern D Configuration 3, and Pattern E. With nearly 10 testing run, Pattern C has greater sound and vibration for the right-way drivers than for wrong-way drivers. With this in mind, the directions of right and wrong ways can be reversed to function as the DRS. Pattern D Configuration 3 and Pattern E both had triangle strips; the edge of these strips could be red in color to further provide a visual warning to the wrong-way drivers. Moreover, multiple sets of strips of the selected patterns (Pattern C, Pattern D Configuration 3, and Pattern E) can be implemented to the real

freeway exit ramps for the evaluation of safety effectiveness in the following stage. Based on their performances at particular speed range, Pattern C was suggested for installation near the end of the off-ramp with 10-25 mph vehicle speed. Pattern D Configuration 3 and Pattern E were suggested in the middle or the end of the off-ramps.

REFERENCES

1. Arizona Department of Transportation (ADOT), Jun 25, 2014. <http://www.azdot.gov/media/blog/posts/2014/07/02/adot-testing-larger-wrong-way-signs>. Visited by 12/22/2015.
2. ADOT. Signing and Marking Standard Drawings. <http://www.azdot.gov/business/engineering-and-construction/traffic/signing-and-marking-standard-drawings/current>. 2014. Visited by 12/22/2015.
3. Bahar, G, Erwin, T, Mackay, M, Smiley, A, Tighe, S, Best Practice Guidelines for the Design and Application of Transverse Rumble Strips. Transportation Association of Canada ISBN: 978-1-55187-211-0, 2005.
4. Corkle, J., M. Marti, D. Montebello. Synthesis on the Effectiveness of Rumble Strips, 2001.
5. Conference of European Directors of Roads (CEDR). *Shoulder and Median Rumble Strips*, 2010.
6. Elefteriadou, L., M. El-Gindy, D. Torbic, P. Garvey, A. Homan, Z. Jiang, B. Pecheux, and R. Tallon. *Bicycle Tolerable Shoulder Rumble Strips*. Pennsylvania Department of Transportation, Harrisburg, 2000.
7. Florida Department of Transportation (FDOT). <http://tbo.com/news/crime/two-days-two-wrong-way-drivers-on-same-road-20141002/>, October 2014. Visited by 12/22/2015.
8. FHWA Research and Technology. Rumble Strips. <http://www.fhwa.dot.gov/research/deployment/rumblestrips.cfm>. 2014.
9. FHWA. Manual on Uniform Traffic Control Devices, 2009 Edition. http://mutcd.fhwa.dot.gov/pdfs/2009r1r2/pdf_index.htm, visited on Oct 16, 2014.
10. Fitzpatrick, K., M. A. Brewer, and A. H. Parham. *Left-Turn and In-Lane Rumble Strip Treatments for Rural Intersections*. Publication FHWA/TX-04/0-4278-2, 2003.
11. Green, R., and Wright, D.T., *Human Sensitivity to Vibration, The Ontario Joint Highway Research Programme*, Report No. 7, February 1959.
12. Harris, C.M., *Shock and Vibration Handbook*, McGraw-Hill, Inc., 1987.
13. Harder, K.A., J. Bloomfield, and B. Chihak. The Effects of In-Lane Rumble Strips on the Stopping Behavior of Alert Drivers. *Human Factors Research Report No. MN/RC-2002-11*, Minnesota Department of Transportation, St. Paul, MN, 2001.
14. Harder, K.A., Bloomfield, J.R., and Chihak, B.J. *Stopping Behavior at Real-World Stop-Controlled Intersections with and Without In-Line Rumble Strips*. Publication MN/RC-2006-42, 2006.
15. Harwood, D.W. Use of Rumble Strips to Enhance Safety. Synthesis of Highway Practice 191, National Cooperative Highway Research Program, National Academy Press, Washington, D.C., 1993.
16. Horowitz, A. J., and T. Notbohm. *Testing Temporary Work Zone Rumble Strips*. Midwest Smart Work Zone Deployment Initiative, www.ctre.iastate.edu/smartwz/reports/MwSWZDI-2005-HorowitzTemporary_Rumble_Strips.pdf. 2005.
17. Iowa DOT. *Traffic and Safety Manual*, Iowa Department of Transportation, Ames, IA., 2006.

18. Kittelson & Associates, Inc., Midwest Research Institute Synectics, Inc., and Transportation Research Corporation. NCHRP web-only Document 124: Guidelines for Selection of Speed, 2007.
19. Kermit, M.L., and T.C. Hein. *Effect of Rumble Strips on Traffic Control and Drive Behavior*. Traffic and Operations, 1962, pp. 469-481.
20. Liu, P., J. Huang, W. Wang, and C. Xu. Effects of transverse rumble strips on safety of pedestrian crosswalks on rural roads in China. *Accident Analysis and Prevention*, Vol. 43, pp. 1947–1954, 2011.
21. Lank, C., and B. Steinauer Increasing Road Safety by Influencing Drivers’ Speed Choice with Sound and Vibration. *In Transportation Research Record: Journal of the Transportation Research Board*, No. 2248, Transportation Research Board of the National Academies, Washington, D.C., 2011, pp. 45–52.
22. Maryland Department of Transportation State Highway Administration. *Guidelines for Application of Rumble Strips*. 2011.
23. MoDOT. <http://fox2now.com/2014/11/03/modot-rolling-out-new-warning-lights-to-stop-wrong-way-drivers/>. Visited by 12/22/2015.
24. Minnesota Local Research Board Report No. MN/RC-2002-07, Minnesota Department of Transportation, October, 2002.
25. New York Department of Transportation, December 4, 2013. <http://www.buffalonews.com/city-region/high-tech-sign-seeks-to-prevent-wrong-way-drivers-from-entering-thruway-20131204>. Visited by 12/22/2015.
26. National Transportation Safety Board. *Highway Special Investigation Report: Wrong-Way Driving*. December 11, 2012.
27. MnDOT. Traffic Engineering Manual, Minnesota Department of Transportation, St. Paul, MN, 1999.
28. MDT. Federal Aid Project No. STPP 13-3(4)83. *Grade, Gravel, Plant Mix Surfacing, Drainage Sappington Junction-south Jefferson County*, 2004.
29. MDOT. Traffic and Safety Note 609C. Sept 20. http://mdotcf.state.mi.us/public/tands/Details_Web/mdot_note609c.pdf. 2011.
30. Miles, J. D., M. P. Pratt, and P. J. Carlson. Evaluation of Erratic Maneuvers Associated with Installation of Rumble Strips. *In: Transportation Research Record: Journal of the Transportation Research Board*, No. 1973, Transportation Research Board of the National Academies, Washington, D.C., 2006, pp. 73–79.
31. Miles J. D., and M. D. Finley Factors That Influence the Effectiveness of Rumble Strip Design. *In: Transportation Research Record: Journal of the Transportation Research Board*, No. 2030, Transportation Research Board of the National Academies, Washington, D.C., 2007, pp. 1–9.
32. Outcalt, W. *Bicycle-Friendly Rumble Strips*. Publication CDOT-DTD-R-2001-4, 2001.
33. Ohio Department of Transportation (ODOT), BOWLING GREEN. <http://www.dot.state.oh.us/districts/D02/newsreleases/Pages/ODOT.aspx> Issued by 6/13/2012. Visited by 12/22/2015.
34. Oregon DOT. Technical Service Details. Nov 15. ftp://ftp.odot.state.or.us/techserv/roadway/web_drawings/details/traffic/pdf/det4552.pdf. 2013.
35. Perkins, D.D., and B.L. Bowman. Effectiveness Evaluation by Using Non Crash

- Measures of Effectiveness. *In Transportation Research Record: Journal of the Transportation Research Board*, No. 905, National Research Council, Washington D.C., 1983, pp. 138–142.
36. Rinde, E. An Off-Ramp Surveillance. California Department of Transportation (DOT). August, 1978.
 37. Rhode Island Department of Transportation (RIDOT). Wrong Way Crash Avoidance. http://www.dot.ri.gov/community/safety/wrong_way.php. Visited by 12/22/2015.
 38. State of New Hampshire. Revised Guidelines for Installation of Milled Rumble Strips on New Hampshire Highway, November 1, 2013. http://www.nh.gov/.../2013_11_01_milled_rumble_strips.pdf, 2013.
 39. Sarah, S., Reza, K. (2015) Automatically Detecting Wrong-Way Drivers on the Highway System. *Transportation Research Board Annual Meeting 2015*, Paper #15-1299.
 40. Smith, J.D., *Vibration Measurement and Analysis*, Butterworths, London, 1989.
 41. Texas Department of Transportation. *Standard Sheets for Edgeline, Centerline and Transverse Rumble Strips*. <https://www.dot.state.tx.us/insdtdot/orgchart/cmd/cserve/standard/toc.htm>. 2006.
 42. Transportation Research Board. (1976). *Design and Control of Freeway Off-Ramp Terminals*. NCHRP Synthesis of Highway Practice.
 43. Schrock, S. D., K. P. Heaslip, M. H. Wang, R. Jasrotia, and R. Rescot. Closed-Course Test and Analysis of Vibration and Sound Generated by Temporary Rumble Strips for Short-Term Work Zones. *In Transportation Research Record: Journal of the Transportation Research Board*, No. 2169, Transportation Research Board of the National Academies, Washington, D.C., 2010, pp. 21–30.
 44. Shaik, N. M., Kristen L. Sanford Bernhardt, and Mark R. Virkler. *Evaluation of Three Supplementary Traffic Control Measures for Freeway Work Zones, Mid-Continent Transportation Symposium Proceedings*. 2000.
 45. Thompson, T. D., M. W. Burris, and J. Paul. Speed Changes Due to Transverse Rumble Strips on Approaches to High-Speed Stop-Controlled Intersections. *In Transportation Research Record: Journal of the Transportation Research Board*, No. 1973, Transportation Research Board of the National Academies, Washington, D.C., 2006, pp. 1–9.
 46. USDOT, FHWA. *Safety Evaluation of Transverse Rumble Strips on Approaches to Stop-Controlled Intersections in Rural Areas*. Summary Report, 2012.
 47. Virginia Department of Highways and Transportation (VDOT). An Evaluation of the Effectiveness of Rumble Strips. Traffic and Safety Division Evaluation No. 81-5, 1983.
 48. Vaswani, N. K. *Case Studies of Wrong-Way Entries at Highway Interchanges in Virginia*. *Transportation Research Record* 514, pp. 16-28, 1974.
 49. Wang, M. H., S. D. Schrock, C. Bornheimer, and R. Rescot. Effects of Innovative Portable Plastic Rumble Strips at Flagger-Controlled Temporary Maintenance Work Zones. *Journal of Transportation Engineering*, 2013, Vol. 139, pp. 156–164.
 50. Watts, G. R. *The Development of Rumble Areas as a Driver-Alerting Device*. *Supplementary Report 291*. Transport and Road Research Laboratory,

- Crowthorne, United Kingdom, 1977.
51. Washington State DOT, <http://www.columbian.com/news/2011/feb/02/flashing-lights-blink-wrong-way-in-downtown-vancou/>. February 2, 2011. Visited by 12/22/2015.
 52. Zhou, H., J. Zhao, R. Fries, M. Gahrooei, L. Wang, B. Vaughn. *Investigation of Contributing Factors Regarding Wrong-Way Driving on Freeways*. Urbana: ICT. 2012.
 53. Zhou, H., J. Zhao, M. Pour-Rouholamin, and P. Tobias. Statistical Characteristics of Wrong-Way Driving Crashes on Illinois Freeways. In *Traffic Injury Prevention*, 2015.
 54. Walton, S., E. Meyer. *The Effect of Rumble Strip Configuration on Sound and Vibration Levels*. ITE Journal, 2002, pp. 28–32.

APPENDIX A

Directional Rumble Strips Feasibility and Design Survey

This survey is in support of the research project “Directional Rumble Strips for Reducing Wrong-Way Driving Freeway Entries,” a study conducted by Auburn University and Southern Illinois University-Edwardsville and funded by the University Transportation Center (UTC) Region 5 through the University of Minnesota. The purpose is to conduct feasibility studies of different conceptual designs for the directional rumble strips (DRS) and develop a new safety countermeasure for wrong-way driving on exit ramps.



Two examples of Freeway Exit Ramps
(Left: Birmingham; Right: Mobile, Alabama)

The DRS is a variation of transverse rumble strips (TRS, also named in-lane rumble strips). When vehicles roll over the rumble strips from either direction, the conventional TRS provides motorists with the same levels of sound and vibration. The DRS is designed to generate elevated noises and vibrations to warn wrong-way drivers and normal noises and vibrations to slow down the traffic for the right-way direction when they are approaching exit ramp terminals. The survey will take between 5 and 10 minutes to complete, and it is intended to gather information about your thoughts on DRS.

Please write down the Name of your Agency:

Type of Agency:

- State DOT
- Equipment Vendor
- Service Provider
- Other (please describe) _____

1. Do you think the DRS can help reduce the wrong-way driving incidents and accidents on freeways?

- a. Not at all likely
- b. Slightly likely
- c. Moderately likely
- d. Very likely
- e. Completely likely

2. The following are some possible patterns and ideas for DRS. Please rate the appropriateness of models “a” through “e” in their potential to reduce wrong-way driving according to the scale below:

- 1 - Absolutely Inappropriate
- 2 - Inappropriate
- 3 - Slightly Inappropriate
- 4 - Neutral
- 5 - Slightly Appropriate
- 6 - Appropriate
- 7 - Absolutely Appropriate

(a) _____

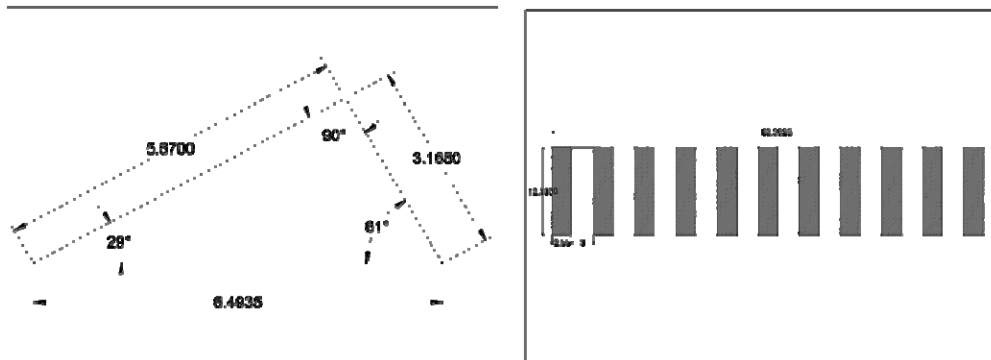

This design constitutes 12 right-angle triangle strips and has 5 feet of spacing between each strip. The left image shows the profile of a single strip. According to the image, if a car travels from left to right, the tire should gradually climb the strip and fall off the back side, making for a smoother ride as compared to traveling from right to left—where the tire will climb much more abruptly, creating dramatic sound and vibration for drivers.

(b) _____

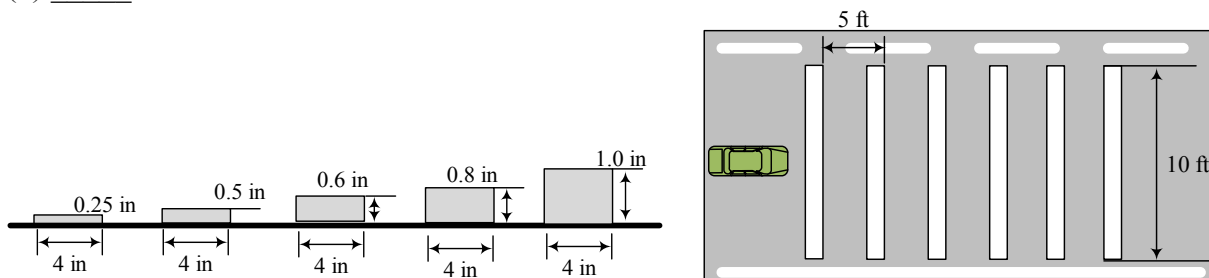

The removable rumble strips may function as the DRS. A 0.25-inch pavement marking strip is placed first and is followed by a 0.5-inch pavement marking strip. The height of the strips gradually increases to 1 inch by combining different thicknesses of tapes. A more aggressive pattern may be made to increase the haptic signals, such as stacking a 0.25-inch pavement marking strip on top of the 1-inch pavement marking strip. The strips in each set are 5 feet apart to generate the best variation in signals.

(c) _____

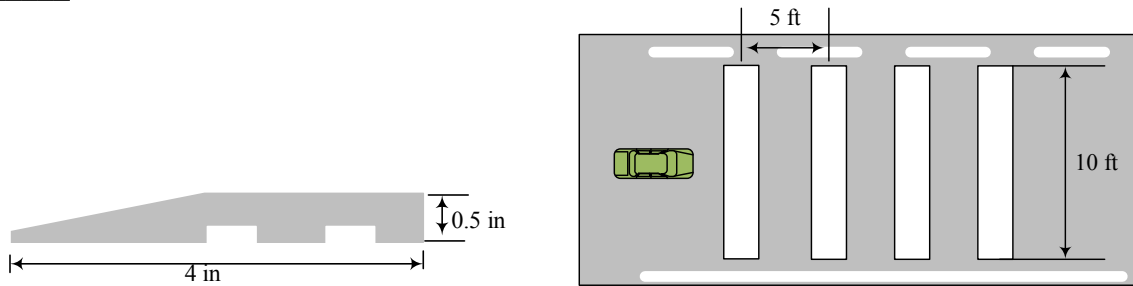

The raised wedge strips may offer audible and tactile signals of DRS. They feature a series of noise steps and a 90 degree drop-off at their trailing edges. The 20 degree angle enables a gradual climb, and the noise steps alert drivers to reduce speed when they travel in the right direction. The 90 degree edge makes it possible to create a more alarming feel for drivers traveling in the wrong direction. There are 4-6 rows of rumble strips across the traffic lanes, and they have 5 feet of spacing in order to make one long strip.

(d) _____

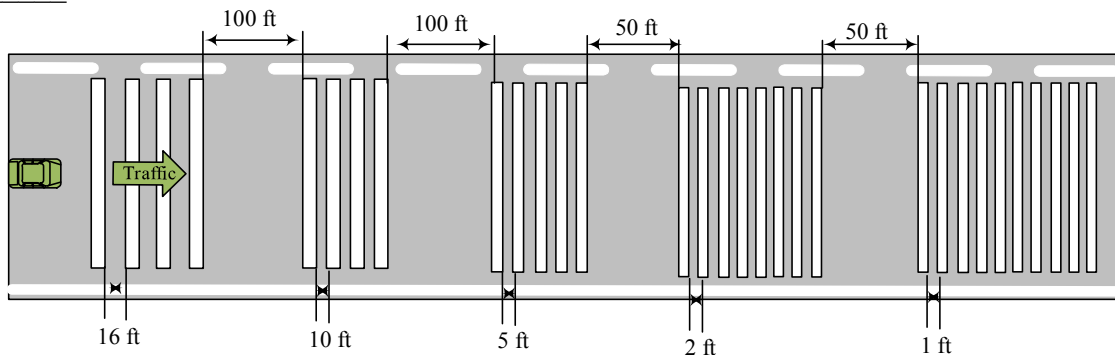

This concept attempts to create different audible and physical warnings by verified number of strips and spacing among them. For a right way driver, the sound and vibration inside the vehicle get gradual increase because of dense strips. While the wrong-way driver will first encounter a noticeable alarming and the warning gradually decrease along the road.

(e) _____

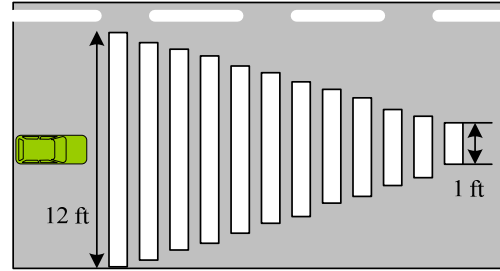
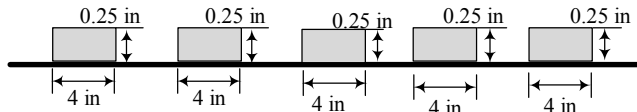

The specifically shaped rumble strip features a set of triangle that also provides visual effects. The length of the strips decreasing from 12 ft. to 1 ft., and all strips are spaced at 1 ft. For the right way, the tires of the vehicle roll over the strips with decreasing length, and the directional arrow act as a guide sign. In the opposite direction, the drivers encounter the increasing strip length, and the arrow gives a visual warning to the wrong-way drivers.

(f)

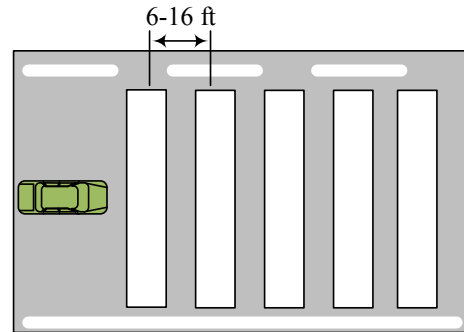
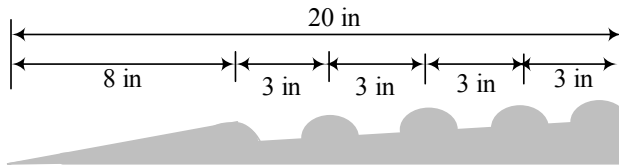

(Reference: Lank C., Steinauer B. (2011). Increasing Road Safety by Influencing Drivers' Speed Choice with Sound and Vibration. Transportation Research Record: Journal of the Transportation Research Board, No. 2248, Transportation Research Board of the National Academies, Washington, D.C., pp. 45–52.)

This design is based on the model of Lank C. and Steinauer B. (2011). It consists of five strips with 6-16 feet of spacing along the driving direction. The width of each strip is 20 inches. Two different components are installed on the angled panel. A raised wedge is about 8 inches in length, which provides a smooth transition for vehicles traveling in the right direction. This is followed by the application of four semicircular raised bands with a maximum height of 0.6 inches (or more) above the pavement. For the wrong-way drivers, the height and the suddenness of the raised bands could generate haptic warning signals.

3. Please rank the properties of the DRS based on your expectation of their potential to reduce wrong-way driving.

- 1 - Low Priority
- 2 - Low-Medium Priority
- 3 - Medium Priority
- 4 - Medium-High Priority
- 5 - High Priority

- ___ Optimum dimensions (e.g., length, width, depth, spacing)
- ___ Visual attentiveness (e.g., retro-reflecting properties and coloring)
- ___ Minimum level of stimuli (i.e., sound or vibration) necessary to alert inattentive drivers

- ___ Impact of noise produced by rumble strips on adjacent residents
- ___ Effect on pavement performance
- ___ Effect on maintenance activities
- ___ Accommodation to motorists' demands in adverse weather conditions, such as snow, fog, and rain
- ___ Others (please specify)_____

4. Does your agency have any product or applications that could work as the DRS for exit ramps?

- a. Yes
- b. No

5. Do you have any ideas or suggestions about the DRS? If available, please also provide materials you are going to use and the estimated cost.

Thank you for contributing to this important study aimed at developing practical designs of DRS, your time and effort will help to make our highways operate safer and more efficiently. Please contact Ms. Lingling Yang or Dr. Hugo Zhou if you have any questions:

Lingling Yang

Master Student, Civil Engineering
Auburn University
Phone: 618-917-8233
E-Mail: lzy0018@auburn.edu

H. Hugo Zhou

Associate Professor, Civil Engineering
Auburn University
Phone: 334-844-1239
E-Mail: zhouhugo@auburn.edu

Raghu Baireddy

Master Student, Civil Engineering
Auburn University
Phone: 408-705-7427
E-Mail: rzb0046@tigermail.auburn.edu

APPENDIX B

Sound and Vibration Profile

Pattern C Right-way and wrong-way signal profiles

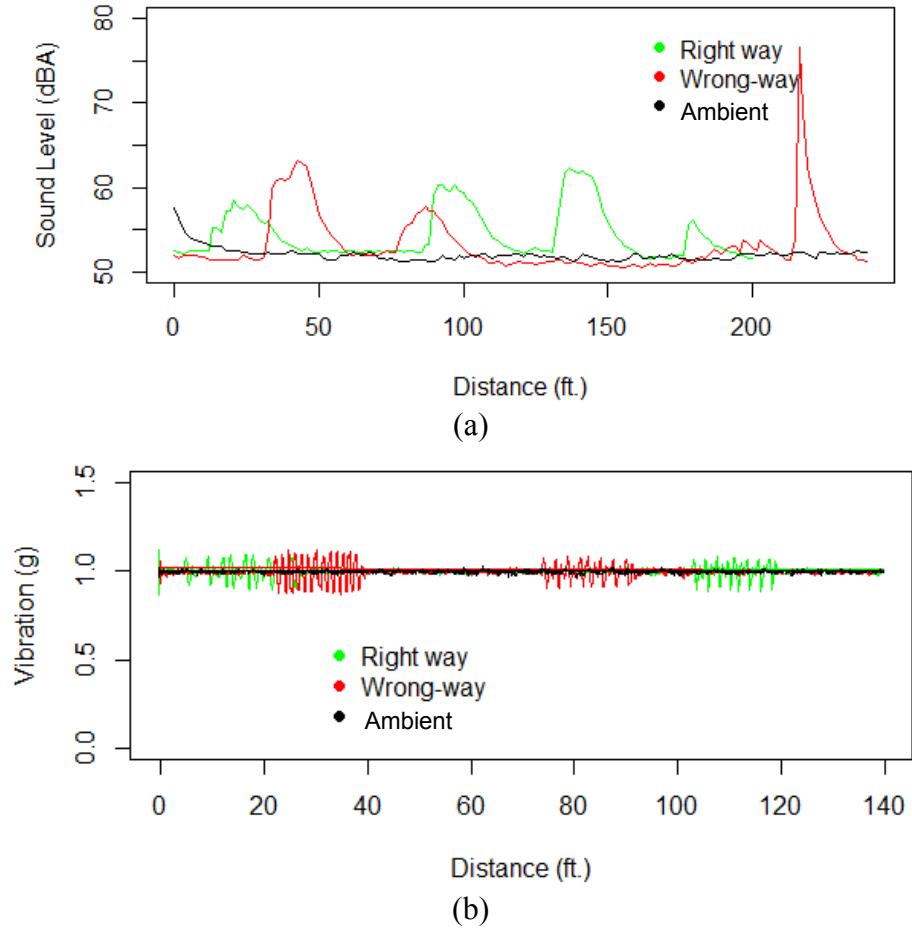
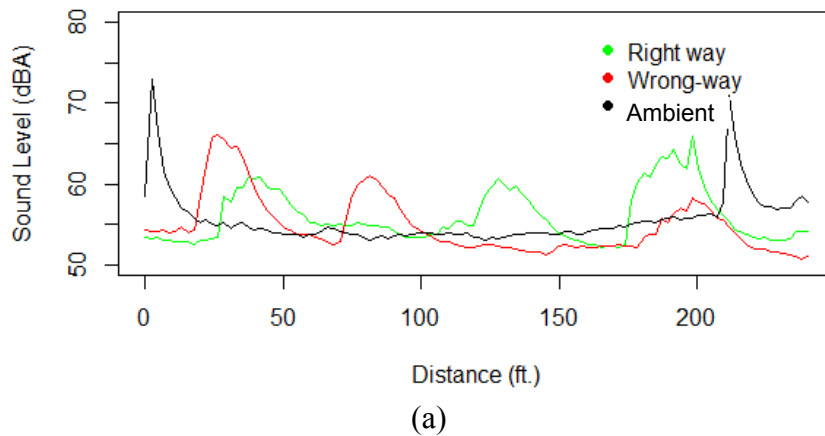
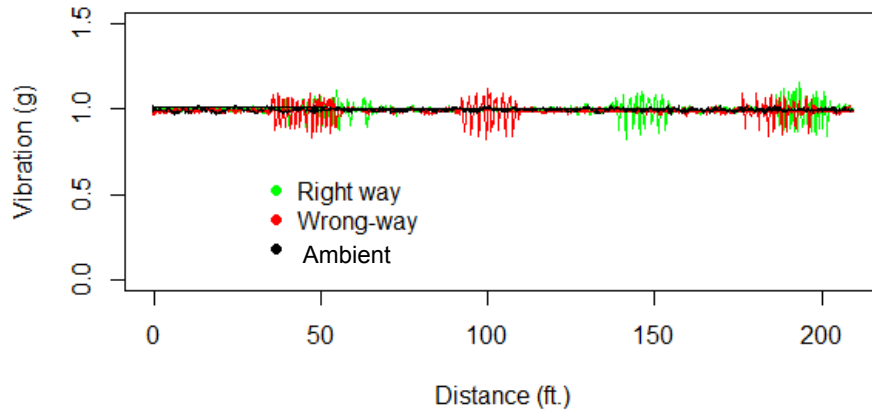

Figure B.1 Sound and Vibration Curve in 10 mph (a: sound, b: vertical vibration)





(b)

Figure B.2 Sound and Vibration Curve in 15 mph (a: sound, b: vertical vibration)

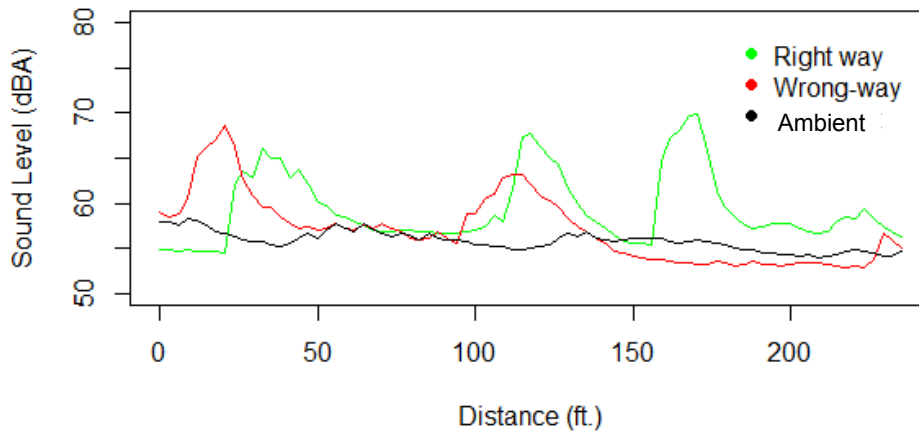

(a)

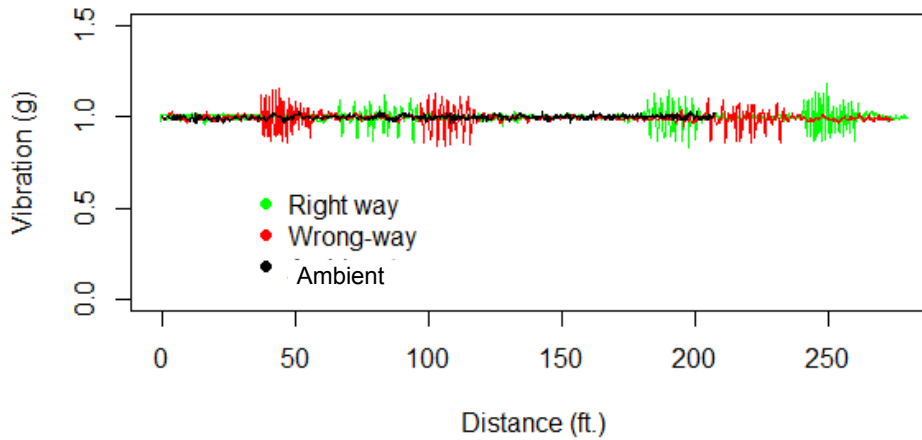

(b)

Figure B.3 Sound and Vibration Curve in 20 mph (a: sound, b: vertical vibration)

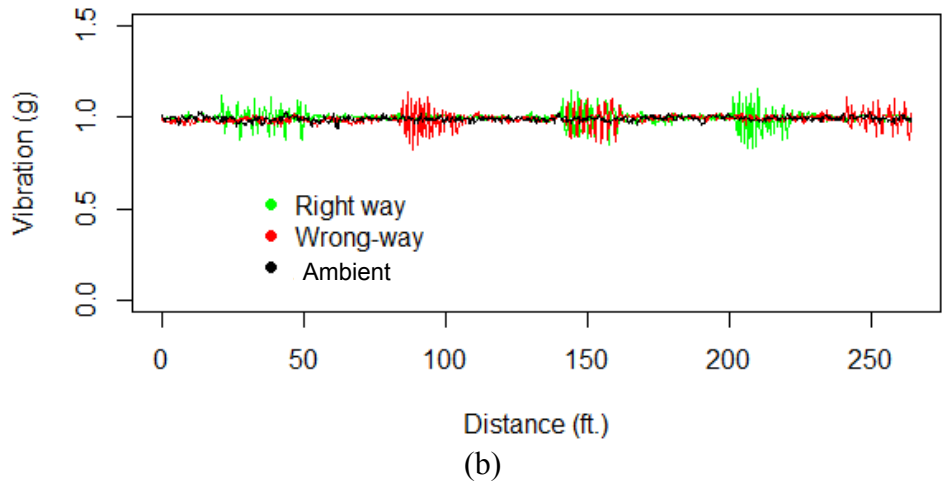
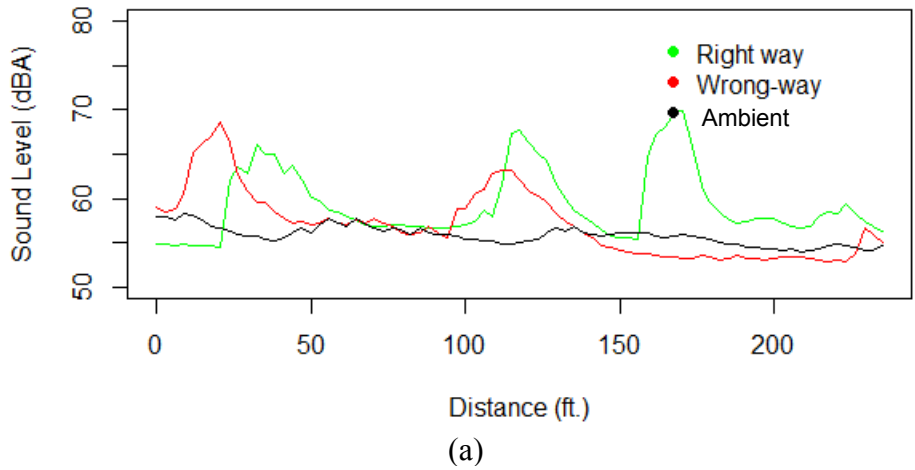
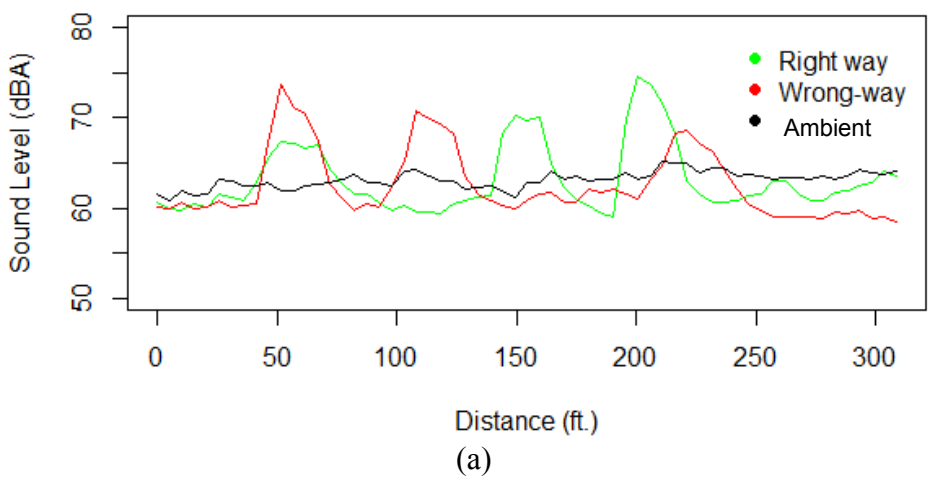

Figure B.4 Sound and Vibration Curve in 25 mph (a: sound, b: vertical vibration)



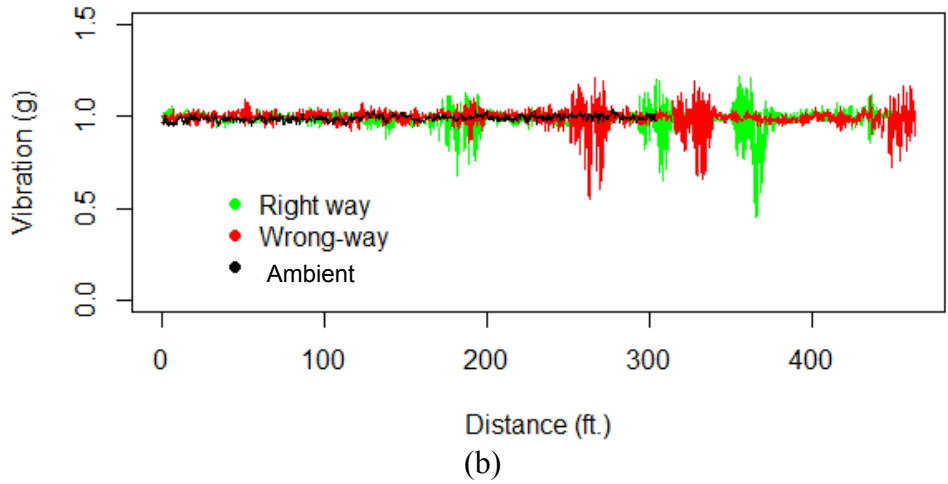

Figure B.5 Sound and Vibration Curve in 35 mph (a: sound, b: vertical vibration)

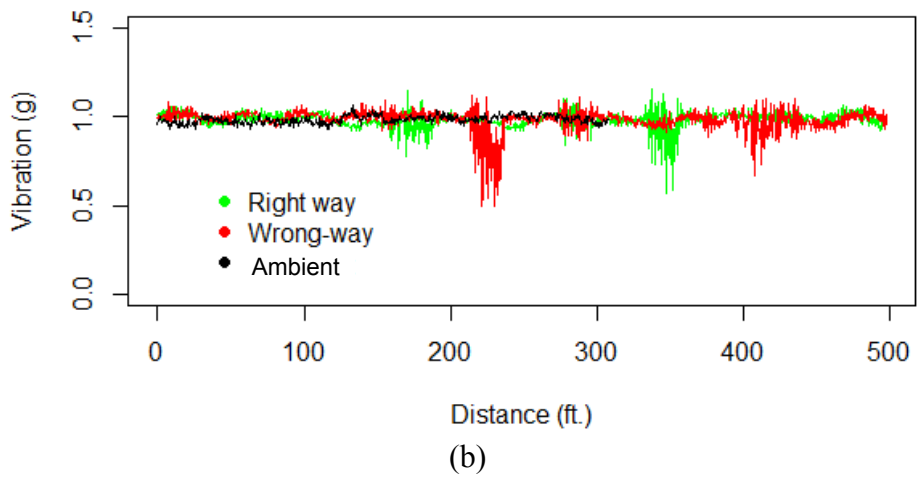
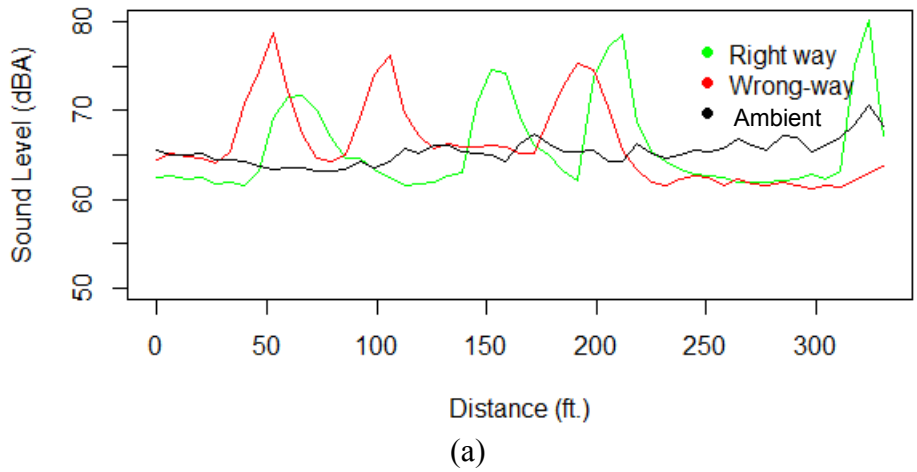
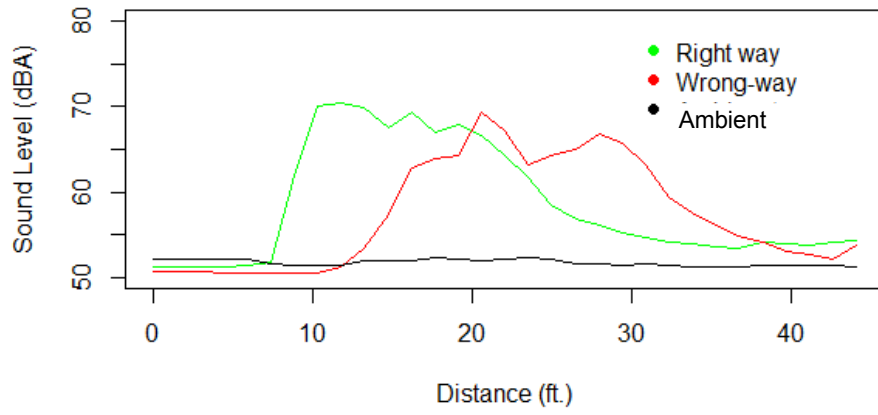
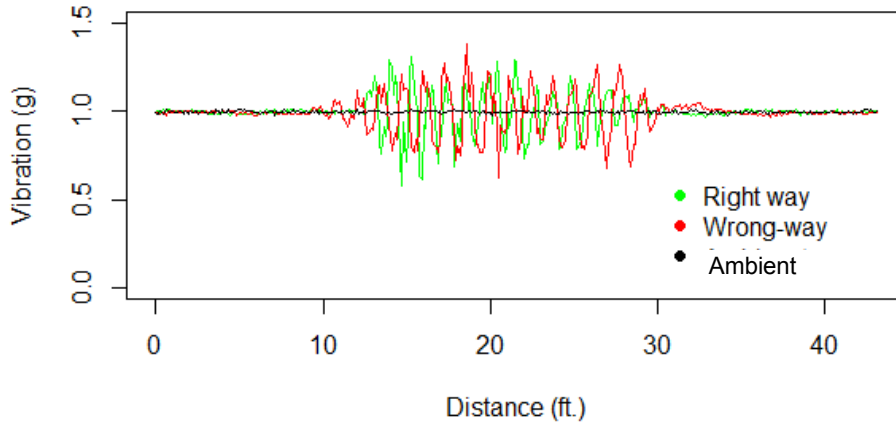

Figure B.6 Sound and Vibration Curve in 45 mph (a: sound, b: vertical vibration)

Pattern D Configuration 3 Right-way and wrong-way signal profiles



(a)



(b)

Figure B.7 Sound and Vibration Curve in 10 mph (a: sound, b: vertical vibration)

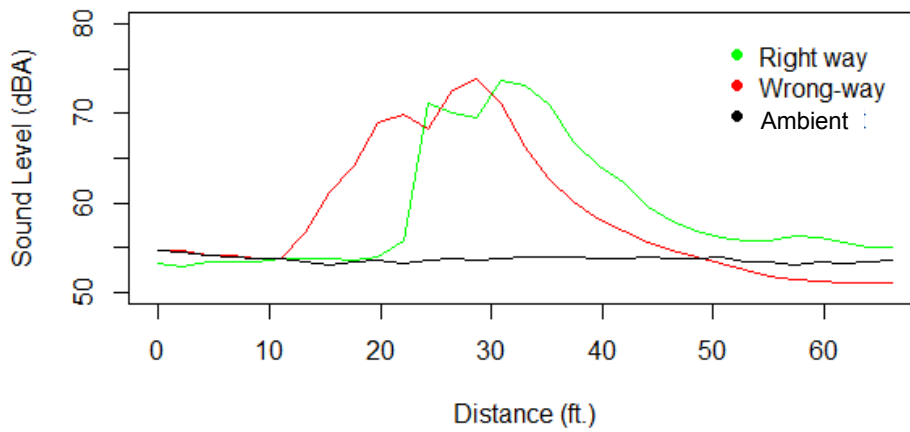

(a)

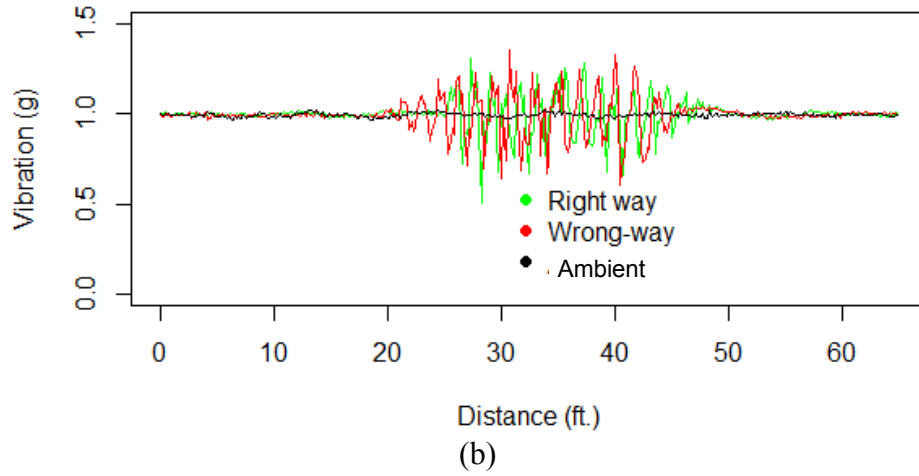

Figure B.8 Sound and Vibration Curve in 15 mph (a: sound, b: vertical vibration)

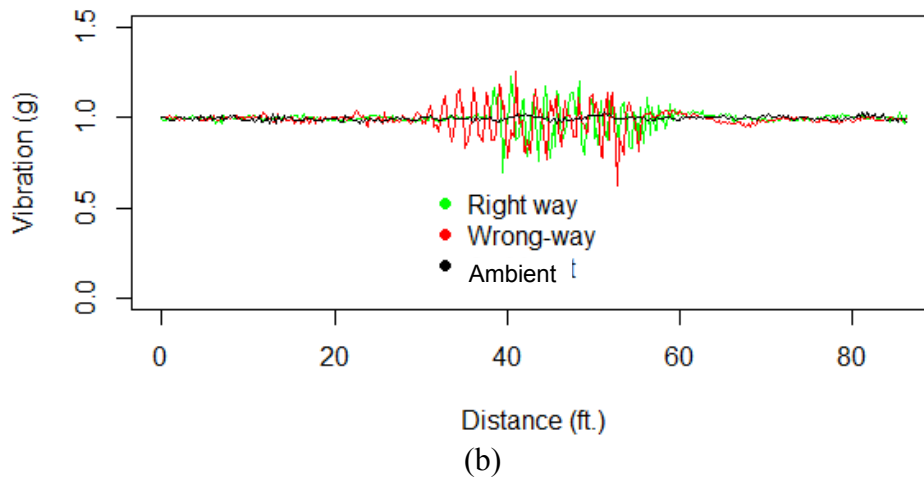
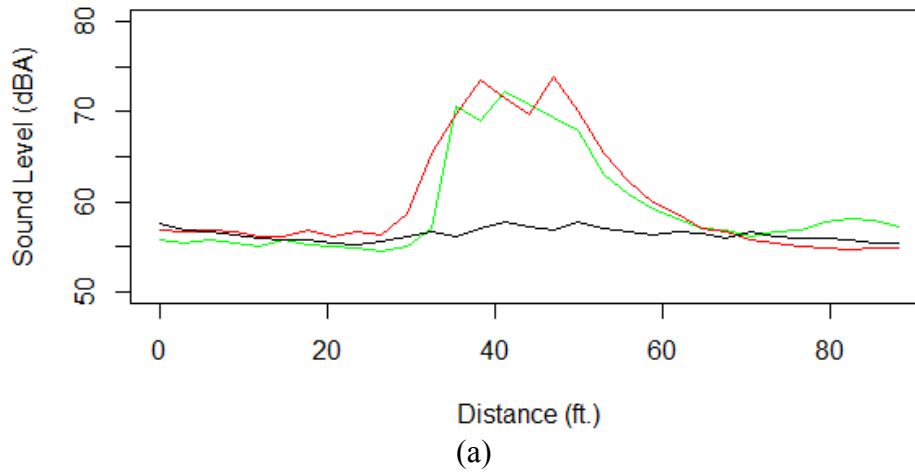
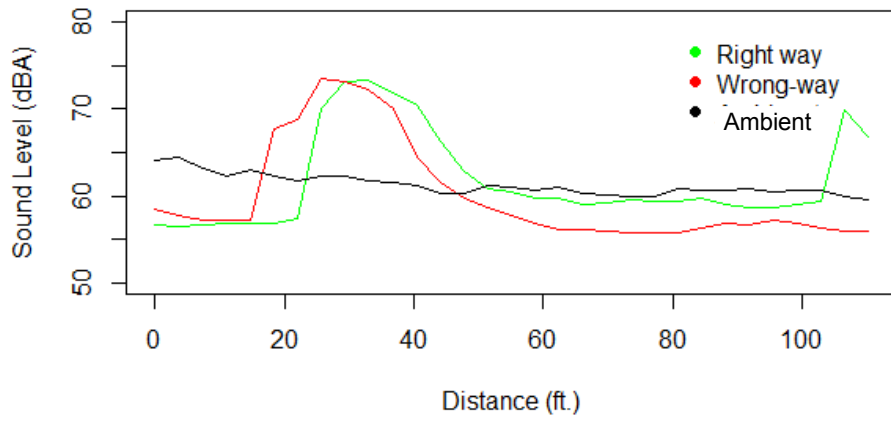
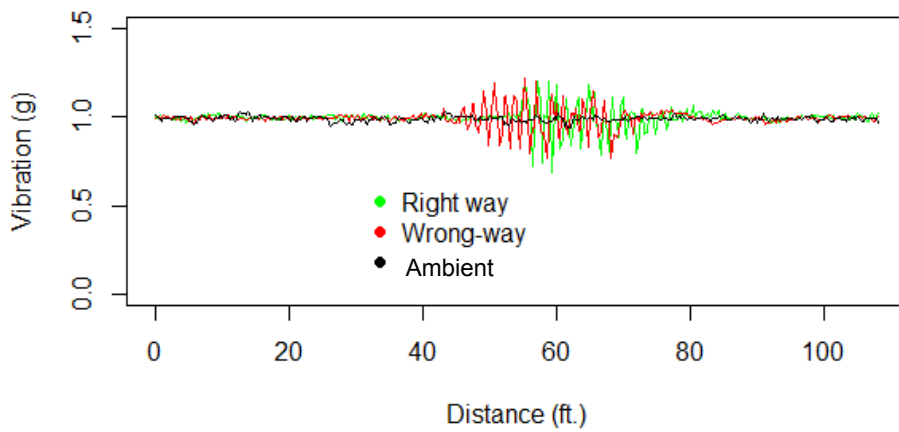

Figure B.9 Sound and Vibration Curve in 20 mph (a: sound, b: vertical vibration)



(a)



(b)

Figure B.10 Sound and Vibration Curve in 25 mph (a: sound, b: vertical vibration)

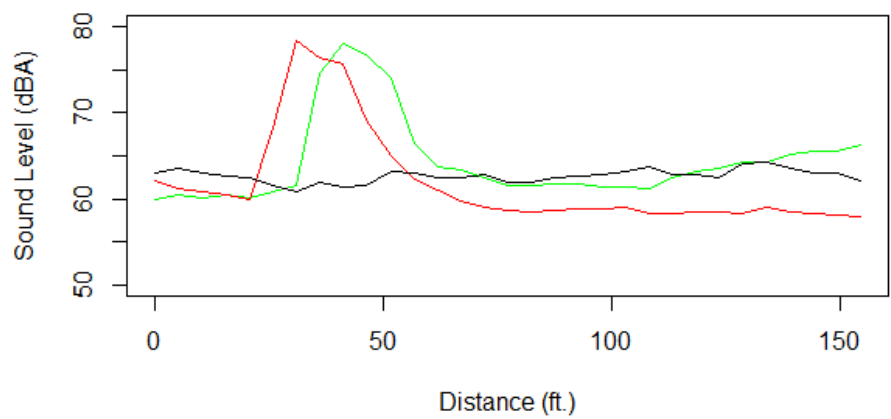

(a)

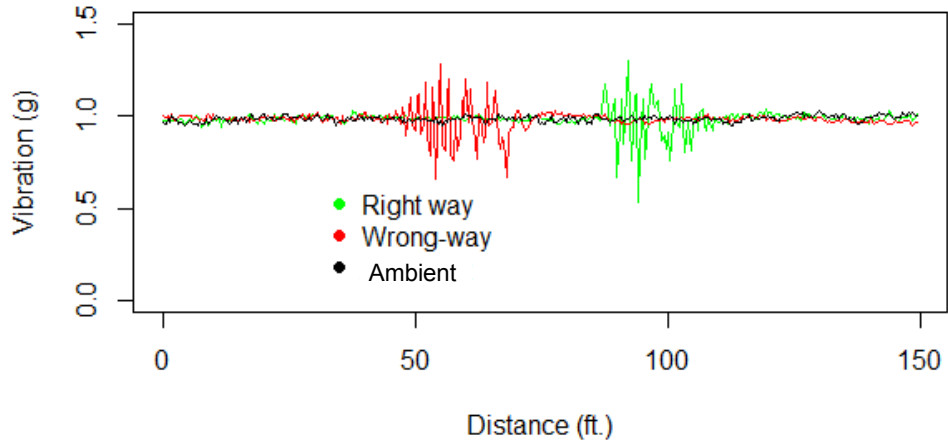

(b)

Figure B.11 Sound and Vibration Curve in 35 mph (a: sound, b: vertical vibration)

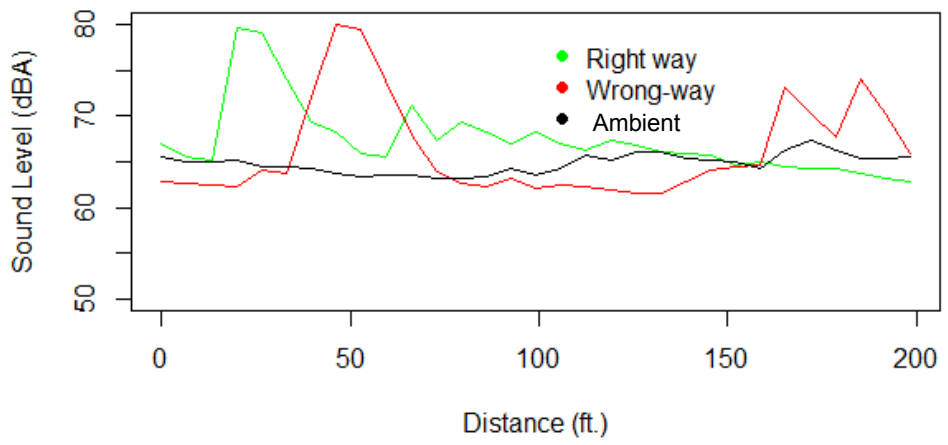

(a)

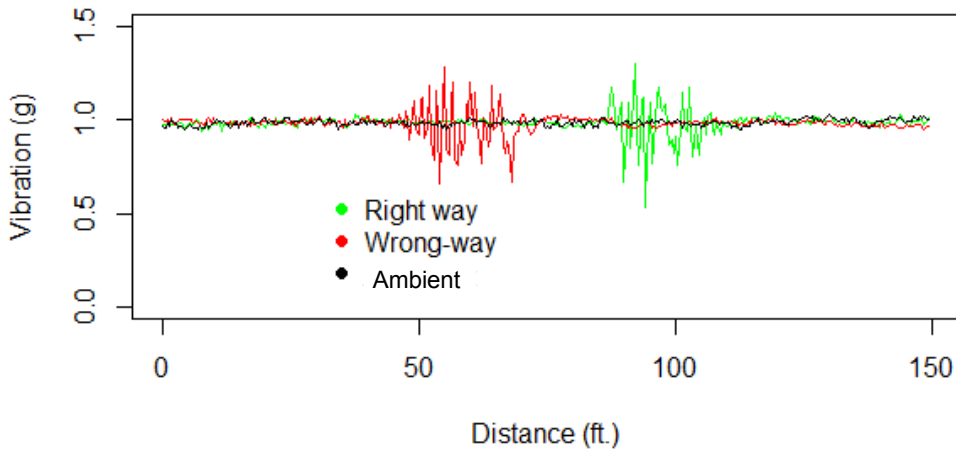

(b)

Figure B.12 Sound and Vibration Curve in 45 mph (a: sound, b: vertical vibration)

Pattern E Right-way and wrong-way signal profiles

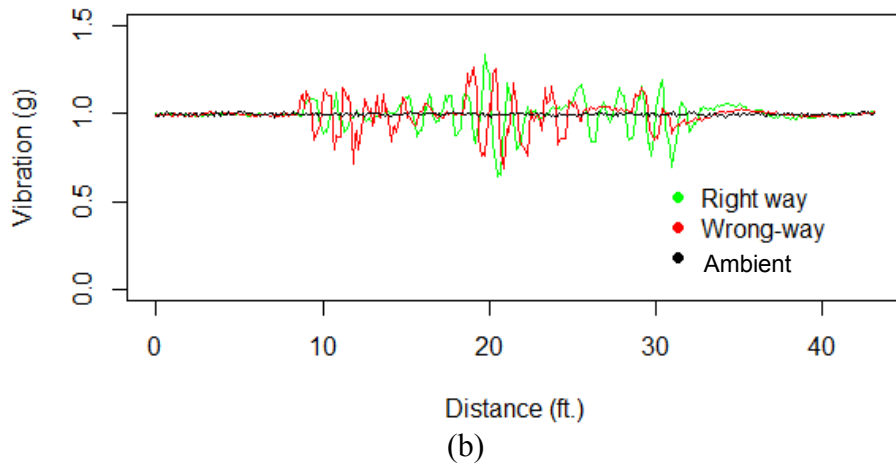
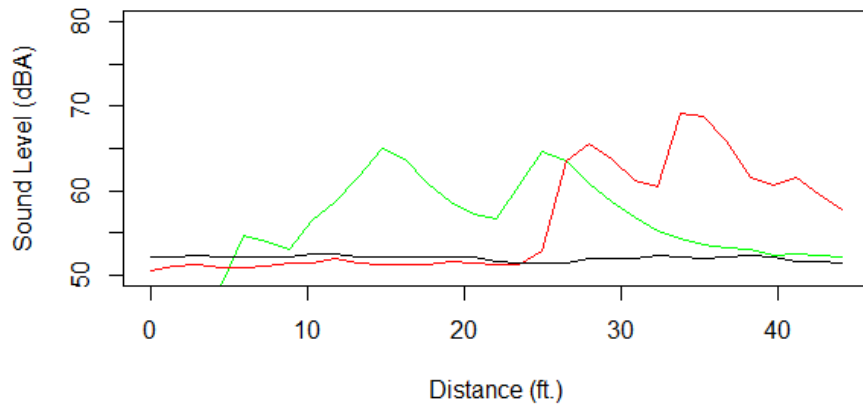
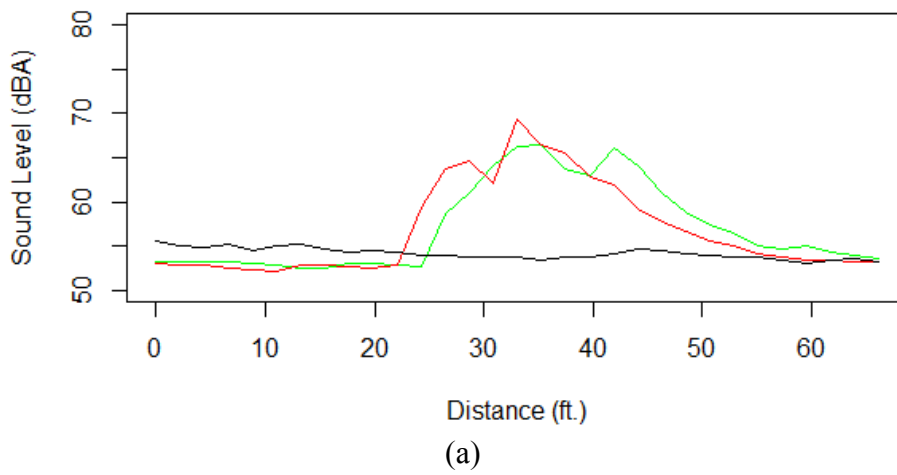

Figure B.13 Sound and Vibration Curve in 10 mph (a: sound, b: vertical vibration)



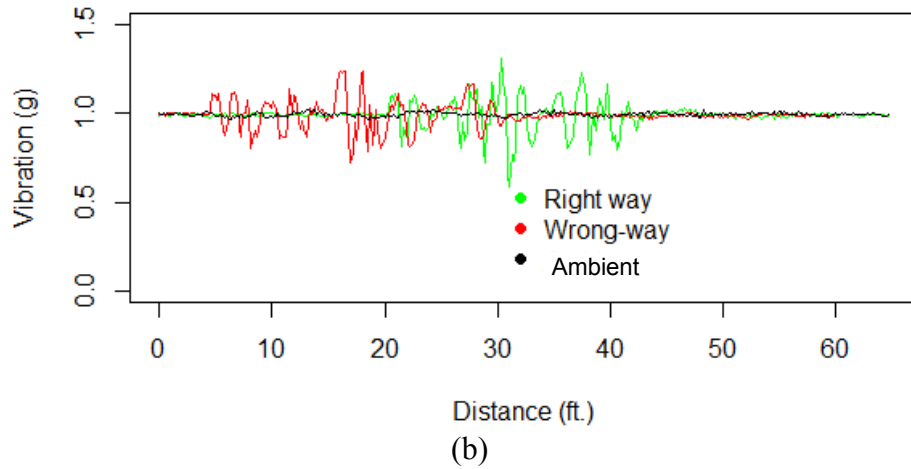

Figure B.14 Sound and Vibration Curve in 15 mph (a: sound, b: vertical vibration)

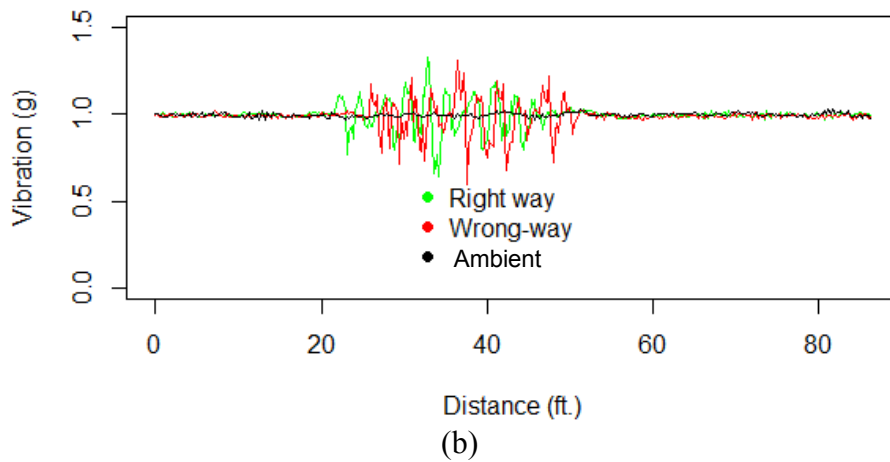
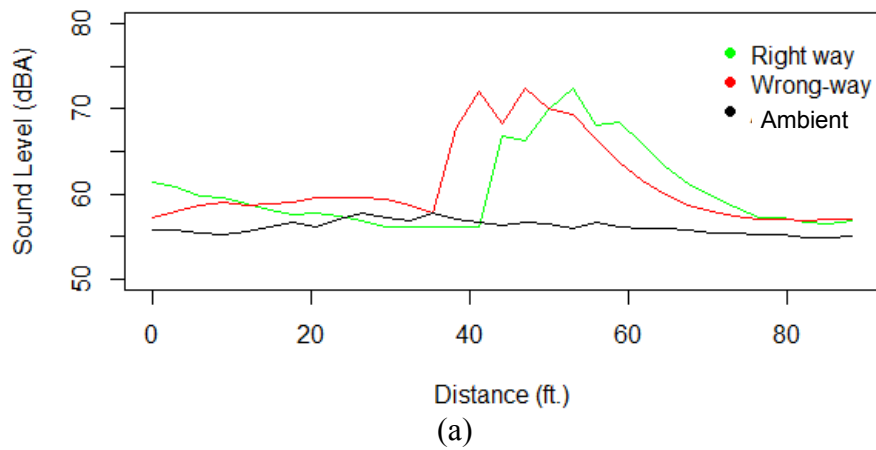
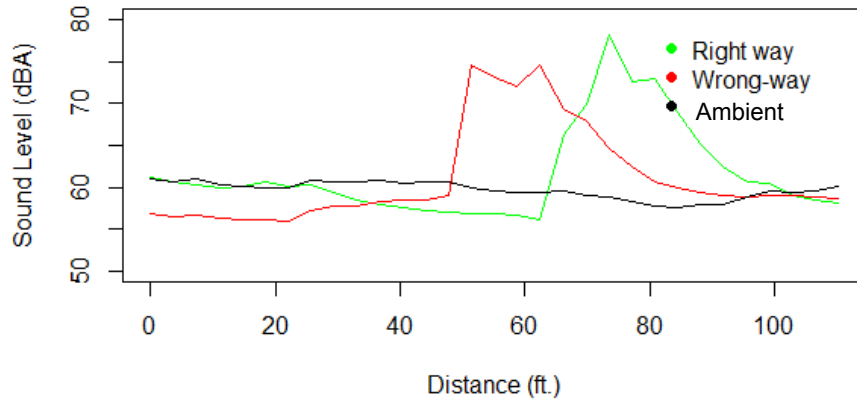
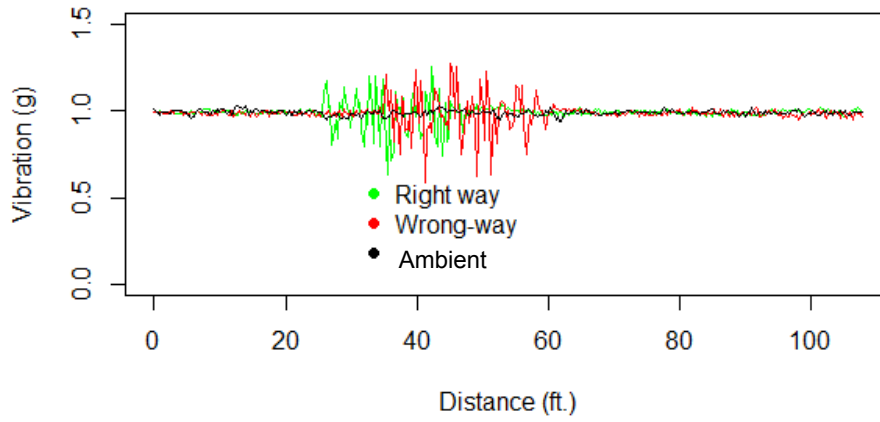

Figure B.15 Sound and Vibration Curve in 20 mph (a: sound, b: vertical vibration)



(a)



(b)

Figure B.16 Sound and Vibration Curve in 25 mph (a: sound, b: vertical vibration)

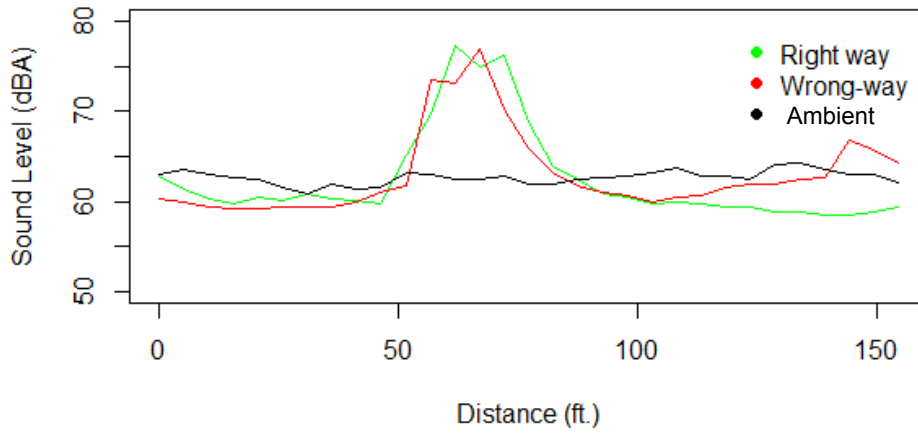

(a)

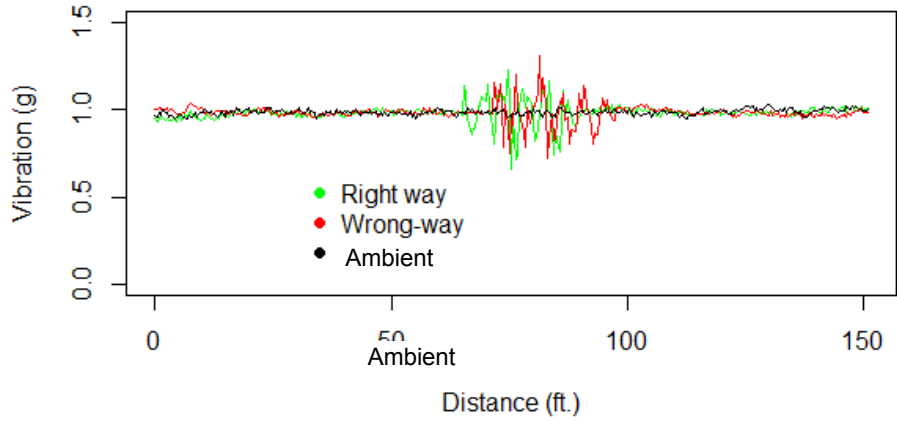

(b)

Figure B.17 Sound and Vibration Curve in 35 mph (a: sound, b: vertical vibration)

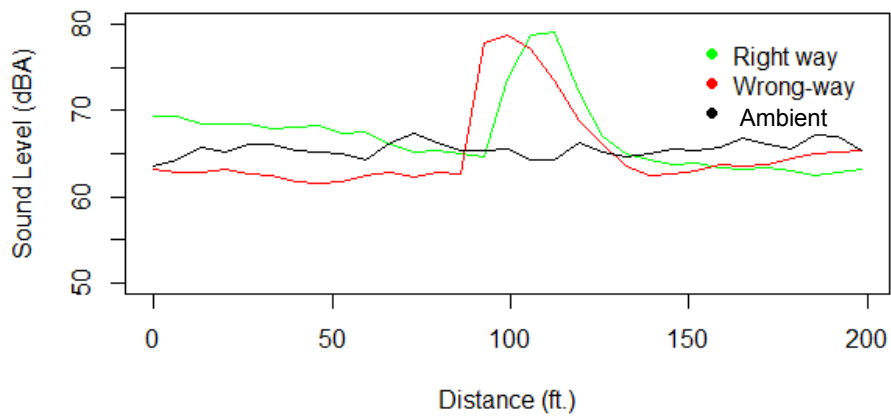

(a)

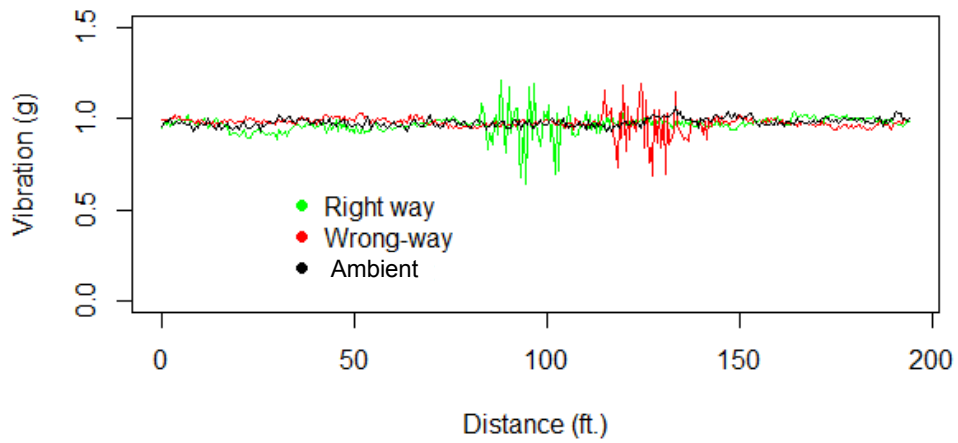

(b)

Figure B.18 Sound and Vibration Curve in 45 mph (a: sound, b: vertical vibration)

Speed test using Minitab

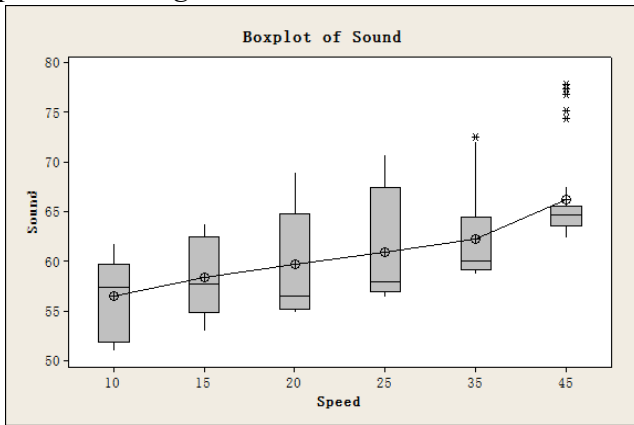

(a)

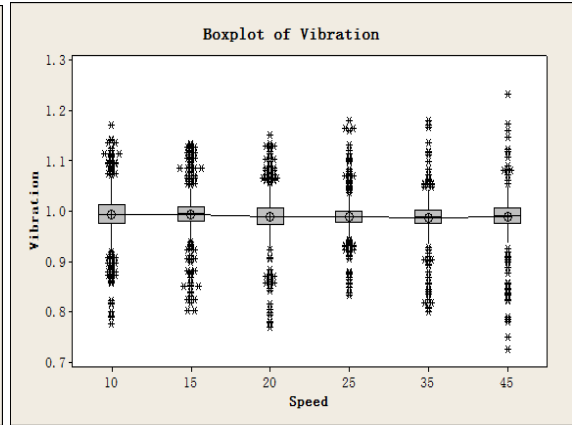

(b)

Figure B.19 Sound level and vibration vs. Speed for Pattern B Configuration 1 (a: sound, b: vibration)

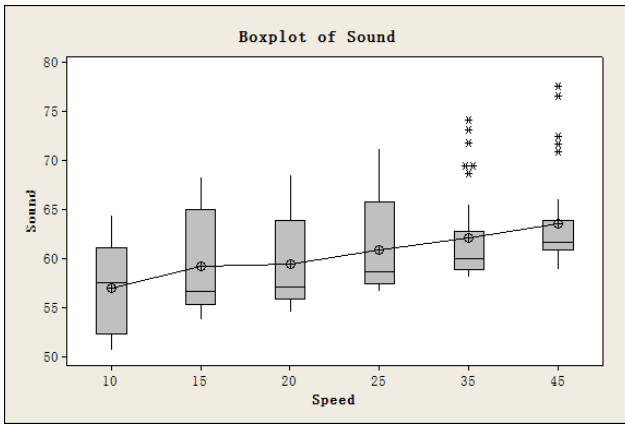

(a)

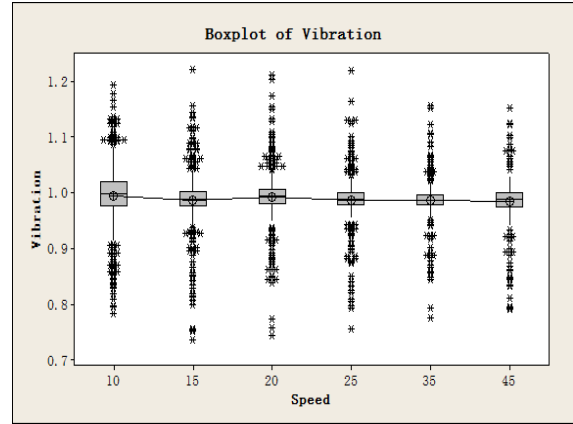

(b)

Figure B.20 Sound level and vibration vs. Speed for Pattern B Configuration 3 (a: sound, b: vibration)

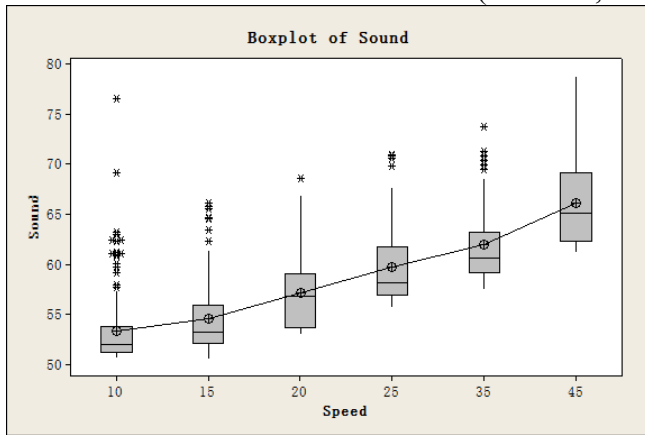

(a)

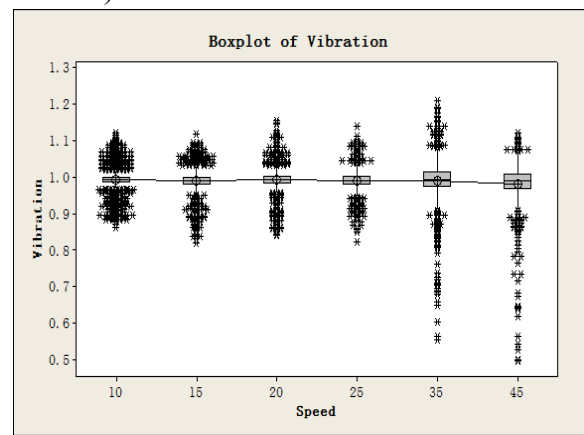

(b)

Figure B.21 Sound level and vibration vs. Speed for Pattern C (a: sound, b: vibration)

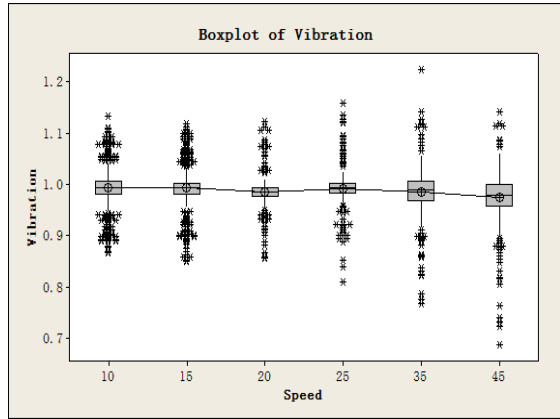
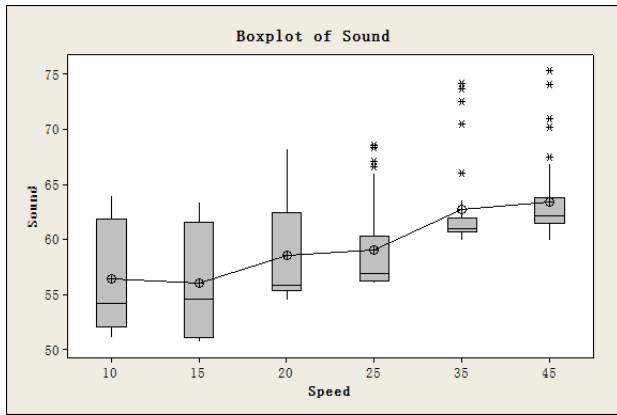

(a)

(b)

Figure B.22 Sound level and vibration vs. Speed for Pattern D Configuration 2 (a: sound, b: vibration)

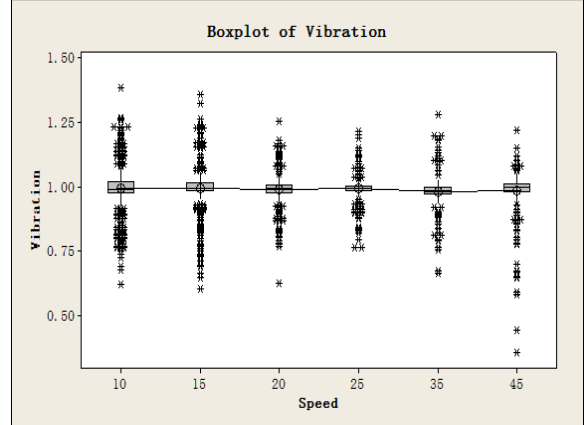
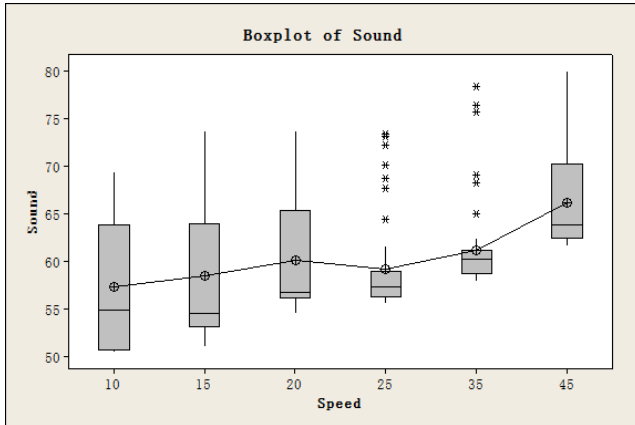

(a)

(b)

Figure B.23 Sound level and vibration vs. Speed for Pattern D Configuration 3 (a: sound, b: vibration)

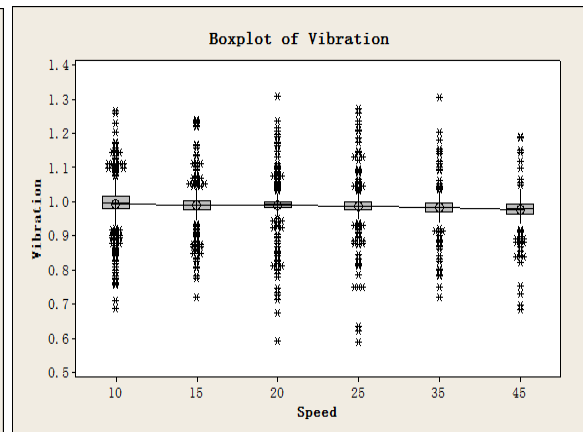
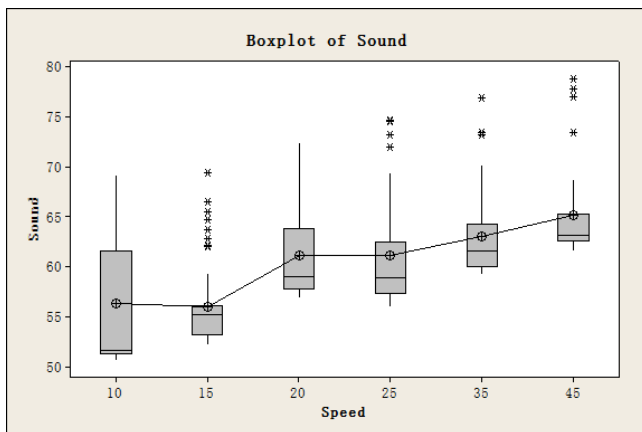

(a)

(b)

Figure B.24 Sound level and vibration vs. Speed for Pattern E (a: sound, b: vibration)

Table B.3 Vibration vs. speed by ANOVA and Tukey's test

Pattern	Significant difference with speed?
Pattern B Configuration 1	No
Pattern B Configuration 2	Yes
Pattern B Configuration 3	No
Pattern C	Yes
Pattern D Configuration 1	Yes
Pattern D Configuration 2	Yes
Pattern D Configuration 3	No
Pattern E	Yes