

**An In Vitro Study Assessing the Effect of Fluid Media on the Mechanical Properties
of Pattern Starting and Ending Surgeon's, Square and Aberdeen knots**

by

Matthew Oliver Duke Coleridge

A thesis submitted to the Graduate Faculty of
Auburn University
in partial fulfillment of the
requirements for the Degree of
Master of Science

Auburn, Alabama
August 5, 2017

Keywords: Suture, knot, colic, linea alba, Aberdeen knot

Approved by

R. Reid Hanson, Chair, Professor of Clinical Sciences
Amelia S. Munsterman, Co-Chair, Clinical Lecturer in Clinical Sciences
Fred J. Caldwell, Associate Professor in Clinical Sciences
Lindsey Boone, Assistant Professor in Clinical Sciences

Abstract

The objective of this study was to investigate the knot holding capacity (KHC) of pattern starting and ending square, surgeon's and Aberdeen knots each tied in 4 throw combinations using either 2USP polydioxanone or 3USP polyglactin 910 after exposure to media commonly found in equine abdominal surgery. An In vitro mechanical study was performed

Strands of 2USP polydioxanone or 3USP polyglactin 910 were exposed to one of four media for 15 minutes. The control suture strands remained dry. The media used included a balanced electrolyte solution, 1% sodium carboxymethylcellulose, equine serum or equine fat. Pattern starting knots and pattern ending knots were loaded to failure in a linear fashion on a materials testing machine to determine KHC.

Start knots tied using either suture exposed to media and end knots tied with 3USP polyglactin 910 had a significantly higher KHC than those tied in dry conditions. No increases in KHC were seen with either suture material used to tie start knots over 5 throws and end knots over 6 throws when suture was exposed to media. Pattern ending surgeon's knots tied using media exposed 3USP polyglactin 910 had a significantly higher KHC than the same dry knots with 5 and 6 throws. Pattern ending square knots tied using media exposed 3USP polyglactin 910 had a significantly higher KHC than the same dry knots at 5

throws. Aberdeen knots tied with either media exposed 2USP polydioxanone or 3USP polyglactin 910 had a significantly higher KHC than their equivalent dry knots. Aberdeen knots had a superior KHC, while requiring less suture than both surgeon's and square knots.

Media exposure either had no effect on KHC, or significantly improved the KHC of all the knots investigated. The most suitable start knot for a continuous pattern closure of the equine linea alba is the surgeon's knot tied using 3 USP polyglactin 910, with 5 throws. Aberdeen knots tied using media exposed 3USP polyglactin 910 with 3 throws and 1 turn are recommended to end the continuous suture pattern.

Acknowledgments

I would like to thank Dr. Amelia Munsterman and Dr. Reid Hanson for providing me with the research and clinical guidance throughout my residency and the duration of the work detailed herein. It is largely due to their insight and expertise that this work was possible. I would also like to thank Ethicon. Ltd. for donating the suture material that was used in this project as well as Dr. Ramsis Farag for his engineering expertise as well as the use of his laboratory and materials testing equipment. Special thanks to my resident mates Mattie McMaster, Alex Gillen, Leah McGlinchey and Ana Velloso for their help and support during this project and throughout my residency. I would like to thank my parents Nick and Gayl Coleridge for their unwavering support throughout my education and career, they have played an enormous role in helping me attain my goals of become an equine surgeon and completing this residency. Finally I would like to give special thanks to my wife Dr. Daria Coleridge who has been essential in supporting me throughout multiple internships and my 3 years at Auburn.



Table of Contents

Abstract	ii
Acknowledgments	iv
Introduction	1
Ventral midline celiotomy	1
Incisional complications	2
Literature Review	5
Suture materials used in large animal surgery	5
Monofilament	5
Multifilament	7
Coated suture	8
Breaking Strength	9
Knot security	11
The effect of media on suture material	16
Short term media exposure	16
Long term media exposure	19
Coated suture material	23
Methods of evaluating the mechanical properties of suture materials and knots	24
The twist test	25
Single cycle to failure tensile testing	26
Inflating bladder	38

Cyclic loading	41
Objectives.....	43
Hypotheses	45
Materials and Methods	46
Results	51
Batch testing of the suture material.....	51
Part 1	51
The effect of media exposure on KHC of:	51
The effect of increasing throw number on KHC.....	54
The effect of suture material and knot type on start and end knot KHC.....	55
The effect of media on knot size.	55
Part 2	56
The effect of media exposure on the KHC of Surgeon's, square and Aberdeen Knots	57
The effect of suture material on KHC.....	58
The effect of knot type on KHC.....	59
The effect of media exposure on knot volume.....	59
Discussion	61
Part 1	61
Part 2	64
Limitations	68
Conclusions	69

References	71
Appendix	80
Methods of knot construction.....	80
Methods of suture/ knot evaluation	82
Figures from Materials and Methods	91
Graphs	94

Introduction

Ventral midline celiotomy

Surgical exploration of the equine abdomen is often performed with the horse in dorsal recumbency and the approach to the abdomen made through a ventral midline incision. In most instances the incision is approximately 20 cm in length, starting 5 cm cranial to the umbilicus and directed toward the xiphoid.¹ When accurately performed skin, subcutaneous tissue and linea alba are transected.² The linea alba consists of the median fibrous raphe of the external and internal abdominal oblique muscles as well as the transverse abdominal muscle aponeurosis.³ At its cranial aspect the linea alba measure 3mm thick, however, it thickens as it courses caudally reaching approximately 10mm.⁴ Due to its fibrous composition, the linea alba acts as the holding layer when the equine abdomen is closed. Its closure must be able to withstand all the pressures exerted by the abdominal contents during anesthetic recovery as well as a period of cyclic loading that lasts 8 weeks as the patient remains on restricted activity during the recovery and healing period.⁵

There are numerous reasons that abdominal surgery through a ventral midline incision would be performed in the horse. Abdominal exploration of the abdominal organs in the diagnosis and treatment of colic is one of the most common indications. Between 1.4 to 10% of colic cases require surgical intervention.^{6,7} Other indications include, surgical intervention of the urogenital system as well as the removal of abdominal masses and the acquisition of intestinal biopsies.

Incisional complications

Incisional complications are of particular concern when they pertain to the equine ventral abdomen. Types of incisional complications include edema, drainage, infection, suture sinus formation, herniation and dehiscence.^{8,9} Complete incisional dehiscence can result in evisceration of the abdominal contents thereby drastically reducing the patients prognosis.¹ Fortunately this particular complication is rare with rates of complete dehiscence following a ventral midline approach ranging from 1% to 3%.^{9,10} However overall rates of incisional complications range from 7.4% to 40%.^{1,9,11-15} Incisional drainage has been reported in 32% to 36% of cases and is considered to be indicative of incisional infection, it has also been correlated with the occurrence of more severe incisional complications such as hernia formation.^{8,13,16-18} Hernia formation has been reported to range from 6% to 17%.¹

Certain risk factors have been identified with respect to the development of incisional complications in the equine colic patient. Horses that present in a more deteriorated condition particularly with a high heart rate, increased total plasma protein, endotoxemia or an increased peritoneal fluid fibrinogen concentration are more likely to suffer incisional complications.^{13,19} Horses in which a two layer closure, consisting of just linea alba and skin, was performed were less likely (18.7%) to develop incisional suppuration than horses in which a three layer closure, which included the subcutaneous layer, was performed (23.9%)(P=0.262).²⁰ Surgical procedures in which the gastrointestinal tract is opened, such as enterotomies, colotomies and resections have been strongly shown to increase the likelihood of incisional complications.^{11,19} Dissection of the linea alba in order to increase

the accuracy of and reduce the inclusion of redundant tissue in the closure bites is also more likely to lead to incisional complications.¹³ The duration of the surgical procedure has also been shown to be related to the rate of incisional complications with longer procedures being more likely to have complications.²¹ Incisional contamination during anesthetic recovery is also more likely to result in incisional complications.²² However, the most significant risk factor is repeat laparotomy. Patients in which the abdomen has to be re-entered for further exploration have been shown to be twice as likely to suffer from post-operative incisional complications.⁹

Incisional complications play a large role in the postoperative morbidity and mortality and are a major cause of nonfatal complications following colic surgery in the horse.⁶ The presence of suture material in surgical wounds has been shown to increase the tissues susceptibility to infection, with even the most inert non absorbable sutures eliciting some degree of reaction.²³ At the time of this thesis no verifiable link has been established between infection and the type or amount of suture material used, however the literature advises surgeons to close the linea alba with a minimally reactive suture material.⁹ It follows that reducing the amount of foreign material placed within an incision line will reduce the inflammatory reaction of the tissue. Studies have shown that simple continuous patterns not only have higher bursting strengths they contain less suture material and less knots than interrupted patterns.^{24,25} The amount of suture material used in the continuous pattern has been optimized for the equine linea alba.^{24,26} Self-locking knots have been shown both in large and small gauge suture material to exhibit superior knot security to the standard square and surgeon's knots currently employed in equine linea alba closure while also requiring

less suture material to construct.²⁷⁻²⁹ Recent work by this laboratory investigated the self-locking Aberdeen knot's performance using large gauge suture in dry conditions.²⁷ By exposing Aberdeen knots to media commonly found in the equine abdominal surgical field, this study aims to verify our previous work while providing more data to support the use of these knots in a clinical setting.

Literature Review

Suture materials used in large animal surgery

Suture materials that are used in large animal surgery include both absorbable and non-absorbable suture materials. These materials can then be made in either a monofilament or braided multifilament form. The range of options of suture material available to the large animal surgeon initiates the question of which is the most appropriate option for a given situation. In determining the answer a large amount of published information has arisen. Today's large animal surgeon has a wealth of literature to draw upon and so can make an educated, informed as well as evidence based choice.

Monofilament

Large gauge monofilament suture materials include glycomer 631, polyglytone 6211, polyglyconate, poliglecaprone, surgical steel, nylon, polyester, polypropylene and polybutester.³⁰ Of these glycomer 631, polyglytone 6211, polydioxanone, polyglyconate and poliglecaprone are absorbable monofilament sutures.³⁰

Monofilament suture materials generally have high material memory meaning that they resist being formed into new shapes. This generally means that they have poor knot security and therefore require several throws resulting in a bulky knot in order to achieve tissue apposition.¹ When these materials are subjected to bending, twisting and clamping, the outer core can be damaged, which will alter the mechanical properties of the material and act as a

point of stress concentration within the strand.¹ The suture material employed in equine linea alba closure is subjected to rough handling and clamping, both manually and with instruments.⁶

Although monofilament sutures do not stand up well to rough handling and have high material memory they have a lower coefficient of friction than multifilament suture materials.³¹ This results in the material exuding less tissue drag.³⁰ In comparison to multifilament materials monofilament suture materials exhibit a reduced tissue reaction as well as a reduced risk of infection.³⁰ Despite these attributes non-absorbable monofilament suture materials are rarely used in closure of the linea alba as they are associated with suture abscesses and sinus formation.³² As the diameter of a monofilament suture increases so does the materials strength and stiffness.^{31,33} Generally due to commercial availability large gauge absorbable monofilament suture materials are popular for linea alba closure, outside of the United States, with 2USP and 7USP polydioxanone being widely used.¹⁰ Although not a synthetic polymer, surgical steel is monofilament and can be employed in closure of the equine linea alba. Although difficult to handle surgical steel does not wick, has excellent tensile strength and knot security; as a result is suitable for use in situations in which the surgeon may be combatting an infectious process such as re-laparotomy through an infected ventral midline incision.^{1,34,35}

Multifilament

Large gauge absorbable multifilament suture materials include surgical gut, polyglactin 910, polyglycolic acid and braided lactomer, Large gauge non absorbable multifilament suture materials include silk and polycaprolactam.³⁰ Of these suture materials, 2USP and 3USP polyglactin 910 are the most commonly employed suture materials when closing the equine linea alba.^{6,14,36} 3USP polyglactin 910 is currently the largest gauge multifilament suture material available in the United States, however 6USP polyglactin is available in Canada and Europe.^{4,10}

Multifilament suture materials cause higher tissue drag than monofilament suture materials. Due to their braided structure they provide crevices that can harbor bacteria out of the reach of the host immune system and systemically administered antibacterial drugs.⁴ Polyglactin 910 has been associated with a higher rate of incisional complications following ventral midline celiotomy when compared with similar gauge monofilament variants.¹⁹ Polyglycolic acid has previously demonstrated superior breaking strength to polyglactin 910 in dry, ex vivo conditions, however no in vivo evidence has been reported to this affect.⁴

Braided suture materials have a higher tensile strength than monofilament suture materials of the same gauge.³⁷ They are also less susceptible to rough handling, have less material memory making them easier to handle, and are less elastic than monofilament suture materials.⁴ Multifilament suture materials also generally demonstrate better knot security

than monofilament suture materials with this knot security increasing with the increasing diameter of the material used.^{33,38}

Coated suture

Both monofilament and multifilament suture materials are coated with different materials in order to augment the properties of the suture material. Common coatings applied to suture materials include antimicrobial formulas and lubricants.

Antimicrobial coatings are applied with the aim of reducing the incidence of incisional complications relating to bacterial contamination and colonization of suture material. Triclosan is a broad spectrum antiseptic that has documented efficacy against both gram-positive and gram-negative bacteria. Triclosan is the coating of choice for medical suture material as it both immediately effective and has a proven safety record, being used in both the skin care product industry and medical sector for over 30 years.³⁹

In vitro assays showed that Triclosan coated polyglactin provided an identifiable antimicrobial effect sufficient to prevent colonization of multiple staphylococcus species.⁴⁰ In rat model studies and in the human medical field antimicrobial coated suture material has shown success. Marco et al. demonstrated a 66.6% reduction in positive cultures post-surgery in rats.⁴¹ Storch et al. demonstrated that antibacterial coated suture material inhibited bacterial colonization of suture after direct challenge with *Staphylococcus aureus*.⁴² Studies performed in human cardiothoracic and pediatric patients demonstrated reductions in post-

operative incisional complications, edema and incisional pain.^{43,44} However in a large study documenting 100 horses undergoing ventral midline celiotomy, no evidence of effectiveness against incisional complications was identified when using antibacterial coated suture material.⁸ Further work into Triclosan coated suture material found an increase incidence of incisional edema was detected in addition to no reduction in incisional complications.⁴⁵

Lubricating coatings are applied to suture materials to reduce their tissue drag, improve their handling properties and in some cases reduce a suture materials capillarity.⁴⁶ Lubricating coatings are generally applied to multifilament braided suture materials such as polyglactin and polyglycolic acid.¹ Examples of lubricants applied to suture materials include silicon, polybutylate and polyamide.⁴⁶ Although coating substances improve the handling characteristics of suture materials, by reducing the coefficient of friction between suture strands they can reduce the knot security, necessitating the need for additional throws to be placed on the knot.^{37,46}

Breaking Strength

A suture's tensile strength is the force that an unaltered strand of suture can withstand when the force is applied in the direction of its length until the suture breaks.³⁰ When a knot is used to join the two ends of a suture strand or is simply placed in the strand of suture, the force used to distract that loop or strand until failure is often referred to as the breaking strength. The precise definition of this term, although widely used in the literature, varies between different publications.^{4,10,47,48}

The tensile strength of unaltered strands of suture material is rarely assessed in the more recent literature. This is undoubtedly due to 2 factors: The large amount of published work detailing that placing a knot in a line of suture greatly decreases its tensile strength and the fact that suture is rarely clinically implemented without the use of a knot. However the original tensile strength of the suture material has a significant impact on the strength of the knot. The strength of the knot when compared to the strength of the suture has been shown to range from 60% to 99% depending on the type of knot and suture material being investigated.⁴⁹⁻⁵¹ in 1985 Von Fraunhofer et al. compared the tensile strength of various absorbable suture materials ranging from 1USP to 3-0USP. They found that the diameter of sutures classified in the same gauge differed depending on the material, this is important when comparing different materials of the same gauge as tensile strength is the load applied divided by the cross sectional area of the sample tested. Therefore, based on the clinical applicability of the work, the breaking loads of the suture were compared as opposed to their tensile strengths. Polydioxanone and polyglactin exhibited the highest failure loads.⁵²

Multiple studies have detailed the breaking strength of suture materials. Breaking strength is significantly affected by the type and gauge of suture material used.^{4,10,53} Fierheller et al. tested 2 large gauge variants of polydioxanone and polyglactin 910 finding that 7USP polydioxanone has a higher breaking strength than 6USP polyglactin 910, 6USP has a higher breaking strength than 3USP polyglactin 910 and that 3USP polyglactin 910 had a higher breaking strength than 2USP polydioxanone.¹⁰ Further work found similar results with regards to the breaking strength of 3USP polyglactin 910 and 2USP polydioxanone, this

study determined that this result remained when the type of knot was also varied between surgeons, square and half hitch knots.⁴⁷

A large amount of tension is placed on the first suture loop of a linea alba closure in order to hold the edges in apposition. In order to facilitate this, some surgeons will secure the first throw of the knot with a clamp while the second throw is placed. Mulon et al. identified that this process does not affect the breaking strength of the multifilament suture materials they investigated, however they did show that it reduced the breaking strength by as much as 10% for the monofilament suture material investigated.⁴⁷

Knot security

Knot security refers to the ability of a knot to withstand the forces placed on the suture it secures without slipping or unravelling. Rosin et al. defined a secure knot as one that broke rather than unraveled or slipped.⁵⁴ When placed under tension until failure knotted suture will break at the knot over 90% of the time.^{10,31,47} There are two main parameters that can be calculated and compared when investigating knot security. Knot Holding Capacity (KHC) is defined as the maximum load to failure when tension is applied to knotted suture material.³⁰ The other parameter is Relative Knot Security (RKS) which has been put forward as a standardized way in which to describe the KHC.³⁰ RKS is defined as the KHC expressed as a percentage of the unknotted suture materials tensile strength (TS):³⁰

$$RKS (\%) = \frac{KHC (N)}{TS (N)} \times 100$$

It should be the surgeon's goal to keep the amount of suture material placed within an incision to the minimum required to accomplish its job. Placing an excess amount of foreign material in an incision can cause inflammation, delays in wound healing, increased probability of infection and patient discomfort.^{33,38,55} The size of the suture material used has also been related to the amount of tissue reaction seen in an incision.³³ This identifies the problem of how many throws should be placed in order to form a secure knot and then what type of knot is the most secure knot?

The most common knots used in equine surgery, especially when closing a ventral midline incision are the square and surgeon's knots.⁵⁶ A knot consists of two throws laid on top of one another and tightened.³⁰ When the second throw is placed in the reverse fashion to the initial throw this is called a square knot.³⁰ When the initial throw consists of two twists of the suture ends, or a double throw, this is called a surgeon's knot. Additional throws can be placed on these knots at the surgeon's discretion. For these knots to be secure they should be tied symmetrically with the surgeon placing an equal amount of force on each end of the suture material.⁵⁵ When tied with asymmetric forces these knots can unwittingly be converted into a series of half hitches and so fail by slipping rather than breaking.⁵⁶ A study evaluating the accuracy of knot tying found that of 25 surgical trainees asked to tie a series of square knots, only 2 consistently tied square knots.⁵⁷ The study went on to determine that the incidence of knot slippage under tension was significantly lower for square knots when compared with attempted square knots.⁵⁷

The square knot is considered to have reduced knot security when compared to the surgeon's knot. In work comparing the load to failure of surgeon's knots and square knots, tied with 3USP polyglactin 910, 2USP polyglactin 910 and 2USP polydioxanone, the surgeon's knot consistently outperformed the square knot, although only in the 2USP polyglactin 910 was this result statistically significant.⁴⁷ Although the surgeon's knot often delivers higher knot security than the square knot studies generally find that this difference is not significant.^{27,50} When a knot is used to end a continuous suture pattern the knot is tied with the working end and the loop of suture prior to the last tissue bite. Incorporating this loop into the knot construction has been proven to reduce the knot holding capacity of the square knot when compared to a pattern starting square knot.^{58,59} In order to compensate for this reduction in strength various authors have recommended the placement of additional throws on square and surgeon's knots used to end continuous suture patterns.^{54,58,59}

Tying a pattern starting knot with between 4 and 5 throws has been found to result in a secure knot.^{47,60} Increasing the number of throws over 5 has been shown to provide no additional knot security when square knots were tied with 0USP polyester, polydioxanone, polypropylene and polyglactin 910.⁶⁰ Rosin et al performed a similar study on smaller gauge 2-0USP suture material in both start and end knot configurations. They found that depending on the suture material between 3 and 5 throws produced a secure start knot, however an additional 1 to 3 throws were required to make the end knot variant secure.⁵⁴ Knots were considered to fail if they slipped or the suture material failed.⁵⁴ These findings have been further corroborated in both large and small gauge suture by more recent studies.^{27,58}

Self-locking knots rely on a sliding mechanism for their strength rather than the surgeon's and square knots that rely on deformation of the suture material.⁵⁹ The surgical literature contains few reports regarding implementation of a pattern starting self-locking knot. The "Forwarder" or "First Stitch" knot was reported initially described by Daes for use during human laparoscopic bariatric surgery.⁶¹ This knot was further detailed by communications in the field of human obesity surgery.⁶² Although these reports detail the improved properties of the knot no evidence has been published detailing its mechanical properties in the human field. The "Half-Blood" knot was initially described by Wattchow et al. in the human surgical literature and then later by Shaw in the veterinary literature.^{56,63} Mulon et al. describe a self-locking start knot that is very similar if not the same as the half-blood knot, the "Delimar" knot.⁴⁷ In 1996, Delimar et al described the knot as a secure knot for suturing structures under tension.⁶⁴ The Aberdeen knot, named by Sir James Learmonth who was the Regius Professor of Surgery at Aberdeen University (1932-1938), is a pattern ending self-locking knot that is widely used in both the human and veterinary fields.^{27,28,31,56,62,65} It has also been referred to as the "Chain-Stitch" knot and the "Loop" knot.^{29,66}

In a study by Shaw et al. in 1995 that tested the KHC of start surgeon's knots with half-blood knots and end surgeon's knots with Aberdeen knots and found that the self-locking knots significantly outperformed the surgeon's knots.⁵⁶ A recent study from this laboratory evaluating the forwarder knot when tied with 2USP and 3USP polyglactin 910 as well as 2USP polydioxanone found it to outperform both square and surgeon's knots in term of both KHC and RKS.⁶⁷ When using small gauge suture material the Aberdeen knot has been shown to demonstrate a significantly higher KHC than square knots while also requiring a

significantly smaller volume of suture material.^{28,29} Other work has also confirmed the Aberdeen knot to be superior to the square knot in terms of knot security and volume when using small gauge suture.^{59,68} When using 2USP and 3USP polyglactin 910 as well as 2USP polydioxanone, this laboratory determined that the Aberdeen knot displayed a significantly higher KHC while remaining significantly smaller than both square and surgeon's knots with the same number of throws.²⁷

Aberdeen knots are constructed by taking the loop created by the last bite of the suture line and passing a further loop formed by the working end of the suture through it (Figure 1.3). This process is considered a single throw and can be repeated at the surgeon's discretion. It is finished by passing the working end through the previously formed loop; this is called the turn.⁶⁵

Stott et al. determined that the ideal Aberdeen knot would be tied with 3 throws and 2 turns.⁶⁵ However more recent veterinary literature has documented the Aberdeen knot being used securely with 4 throws and 1 turn when using small gauge suture 2-0USP polydioxanone.²⁸ Our laboratory found that when the Aberdeen knot was employed using large gauge suture no significant increase in KHC was identified between 3 and 4 throws each with 1 turn when 2USP polyglactin 910 and 3USP polyglactin 910 were tested.²⁷ However, when 2USP polydioxanone was used a significant increase in KHC was seen between 3 and 4 throws.²⁷

The effect of media on suture material

Most laboratory testing of suture material is performed in a single cycle to failure under ex vivo conditions. The majority of the time the suture is taken from its packaging and placed onto the testing apparatus. When suture material is used in a clinical setting, it is exposed to body tissue and fluid present at the surgery site. When large gauge suture is used to close the equine linea alba it is instantly exposed to abdominal fluid, abdominal fat, blood amongst other media. It is important to know whether this exposure changes the way these sutures behave mechanically when tied in knots and placed under tension, as well as how exposure to different media effect the long term strength of the suture material. The literature can be divided into two types of study. Firstly mechanical testing of suture material that has been exposed to a media immediately prior to testing. In this group the effect of the media on the molecular structure of the suture material is minimal. The second group is one that consists of studies that exam how different media effect the strength of suture material after a prolonged period of exposure. One of the major goals of these types of studies is to determine if certain environments or body fluids accelerate the weakening of suture materials.

Short term media exposure

In 1985, Gupta et al. published two reports investigating the effect the frictional properties of suture materials.^{69,70} They investigated how the suture material used affected a suture strands frictional properties determining that the coefficient of friction is a function of applied tension, suture construction and suture material, not a material constant. They also found that as the applied tension to the suture strand increased the coefficient of friction

decreased.⁷⁰ In their second publication that year they investigated the effect that lubrication of suture material has on its frictional properties. Interestingly they discovered that friction between lubricated strands of suture material can both increase and decrease depending on the type and quantity of the lubricant used.⁶⁹ They describe two differing states of lubrication, the boundary state and the hydrodynamic state. In the boundary state a monolayer of lubricant exists on the suture strand that causes the amount of contact points between two strands of suture material to decrease and so a decrease in the coefficient of friction between the strands is realized. In the hydrodynamic state a thick film of lubricant exists between the strands of suture material preventing any direct contact. In this instance the frictional force is governed by the resistance of the lubricating material to shear. Therefore the greater the viscosity of the material the greater the frictional force.⁶⁹ They propose, based on their results using either a saline solution or a concentrated glycerin preparation as their lubricants, that even visibly thin layers of lubricant form a hydrodynamic state. Their results showed that addition of a lubricant increased the coefficient of friction and that as the viscosity of that lubricant increased so did the coefficient of friction between the strands.⁶⁹

The majority of studies investigating suture material that has been subjected to short term media exposure use either saline or plasma as their media.⁷¹ Unfortunately, the majority of these studies do not have direct comparisons to “dry” or unexposed suture material, such as work published by Rosin et al, one of the first studies that describes testing media exposed suture material, who detail running the suture material through canine serum prior to knot construction.⁵⁴ In 2005, Richey et al. investigated square knots and self-locking knots used

to close sections of porcine skin.⁵⁹ Although determining the effect of surgical conditions on the knot holding capacity of self-locking knots was not the aim of this project, and no dry comparison group existed, this was one of the first reports to detail self-locking knots evaluated in ex-vivo conditions.⁵⁹

In human obstetric surgery petroleum soaked packing is used post operatively as a hemostatic device. Previous research evaluating the KHC of serum soaked suture material showed no significant difference, however later commentaries suggested that this was due to rapid evaporation of serum from the suture material causing it to become sticky.⁷¹⁻⁷³ As a result, knowing that lubrication can possibly decrease a knot's KHC, clinicians in this field questioned the impact that a lubricant such as petroleum jelly may have. Muffly et al. compared square knots with 6 throws, tied with 3 different size 0-0 USP suture materials all commonly used in obstetric surgery; polydioxanone, silk, glycolide/lactide copolymer and polyglyconate. The sutures were exposed to either a 0.9% saline solution or placed in a plastic bag with petroleum soaked gauze. They found that knot ties with petroleum exposed suture materials consistently and significantly failed at a lower KHC than those exposed to saline.⁷⁴ Unfortunately no dry group of knots was evaluated.

More recently a study published in the veterinary surgical literature examined the effect that exposing suture material to either plasma or fat had on the KHC of 2-0 USP polydioxanone when tied in both square knots and Aberdeen knots.^{28,29} This study again did not have a dry group with which these media exposed groups could be compared. The study determined

that when tying a start square knot when the suture was exposed to either plasma or fat required 4 throws and that when tying a square end knot in either media, 5 throws were needed. When looking at the self-locking Aberdeen knot they determined that when tied with fat exposed suture material it required 4 throws and 1 turn, as opposed to when tied in plasma where it only required 3 throws and 1 turn. No differences in KHC were identified between square start knots tied with either plasma or fat exposed suture material or square end knots. Aberdeen knots are self-locking knots in which the suture strands slide over each other as tension is applied to the knot.²⁸ They proposed that the added lubrication of a fatty media may have accounted for a decrease in the coefficient of friction between strands, which meant that an extra throw was required when knots were tied with fat exposed suture material.^{28,29}

Long term media exposure

In comparison to investigating the short term effects of media exposure on suture material, ascertaining information on how different in vivo, or simulated in vivo conditions affect the biomechanical properties of suture materials has been investigated more extensively. In 1975 Tera et al. investigated the effects of placing suture within the subcutaneous tissues of rabbits for 7 days when compared to suture strands that had been placed in saline for the same period of time.⁷⁵ They found that suture that had been placed in the living tissue was more susceptible to failure from slippage of the knot and showed a reduction in breaking strength, this held true for both absorbable and non-absorbable suture materials tested. The investigators commented on the variability of results between animals, suggesting that different in vivo conditions between animals may have been a determining factor.^{50,75}

Different surgical fields may expose suture materials to a wide range of conditions with differing acidities. Pathology to an area of interest can change its acidity.⁷⁶ Determining the effect that the acidity of the in vivo conditions have on the retention strength of suture material has been investigated. Chu et al. looked at 8 different suture materials all of size 2-0USP.⁷⁶ The suture materials investigated included polyglycolic acid, polyglycolide-lactide copolymer, catgut, surgical silk, nylon, dacron, and polypropylene. The suture materials were immersed in solutions of differing pH for either 7 or 28 days. They found that absorbable suture materials were more sensitive to pH than non-absorbable suture materials and that alkaline conditions had the most significant effect on reducing the sutures breaking strength.⁷⁶

Further work by Campbell et al also investigated the effect of in vivo implantation, this time in the horse, had on the breaking strength of various size 2USP suture materials, including nylon, polydioxanone and polyglactin.⁴⁸ Suture breaking strength and percentage elongation were evaluated in vitro and then at 7, 14 and 28 days after subcutaneous implantation in horses. They found that over the 28 day immersion period that polydioxanone maintained its mechanical properties far better than polyglycolic acid. None of the target parameters were measurable in the polyglycolic acid after 28 days of in vivo implantation.⁴⁸ This study highlighted the benefits of using polydioxanone to close the equine linea alba over polyglycolic acid which was widely used at the time of publication.⁴⁸

The effect that infection has on the environment in which suture is placed was looked at by Schiller et al.⁷⁷ They compared the mechanical properties of 3-0USP polydioxanone, polyglycolic acid, polyglactin 910 and polyglyconate when incubated in sterile urine with their properties when incubated in *E.coli* and *P. mirabillis* inoculated urine. The suture material was incubated for 28 days. They found, similarly to Chu et al. that more alkalotic conditions caused a greater loss of strength. They also found that the sutures incubated in the contaminated urine had an accelerated loss of breaking strength when compared to the sutures in sterile urine and that polydioxanone consistently outperformed polyglactin 910.⁷⁷ Other studies have confirmed polydioxanone's unmatched ability to maintain its mechanical properties when faced with alkalotic conditions. When exposed to bile and pancreatic secretions for 7 days polydioxanone maintained its tensile strength better than other absorbable suture materials such as polyglactin 910.⁷⁸ When compared with 2 other types of absorbable suture material, poliglecaprone 25 and polyglycolic acid, polydioxanone was again determined to be the better option.⁷⁹ Polydioxanone maintained its mechanical properties better than the other suture materials when incubated in phosphate buffered saline solution (PBSS), milk or milk contaminated with *S. agalactiae* for 21 days.⁷⁹

Two recent reports have investigated the effect that incubating suture material in equine specific physiologic and pathologic solutions, has on its mechanical properties. Kearney et al investigated size 2USP glycolide/lactide copolymer, polyglactin 910 and polydioxanone.⁸⁰ They incubated then for up to 28 days in either phosphate buffered saline solution, equine serum, equine urine and equine peritoneal fluid. The peritoneal fluids were acquired from a subject with severe peritonitis that on bacterial analysis revealed *E. coli* and *Streptococcus*

sp. The unknotted suture material was subjected to tensile testing. They found that the mechanical properties of all the suture materials deteriorated as incubation time increased. Glycolide/lactide copolymer demonstrated the least ability at maintaining its mechanical properties over the study period, while polydioxanone demonstrated the highest ability. Especially when incubated in serum and inflamed peritoneal fluid polydioxanone's tensile strength remained minimally reduced from its baseline.⁸⁰ As a follow up to this investigation the same group performed a similar investigation with the goal of determining the effect of incubation time of knotted suture material in phosphate buffered saline solution and inflamed peritoneal fluid.³¹ They investigate 3 absorbable suture materials, glycolide/lactide copolymer, polyglactin 910 and polydioxanone, all of size 2USP polydioxanone. They tied 3 different knot types, square knots, surgeon's knots and triple knots. A triple knots first throw is made with 3 complete turns of the suture materials. The knots were tied on mounts which were tested dry and then incubated in either media. The knots were incubated for 14 or 28 days. Interestingly when exposed to phosphate buffered saline they found that the KHC of knots tied with polydioxanone increased from day 0 to day 14 and then remained similar for the rest of the study period. The other suture materials showed a decrease in KHC as incubation time in phosphate buffered saline solution increased. When exposed to inflamed peritoneal fluid polydioxanone maintained an increased KHC when compared with the other suture materials at day 14 and 28. With respect to the differing knot types evaluated they found the surgeon's and triple knot to provide a higher KHC than the square knot in all conditions.³¹

Coated suture material

As previously mentioned, some multifilament braided suture materials have coatings applied to them to improve the handling characteristics. Braided multifilament suture materials have the advantage of improved tensile strength per unit of cross sectional area over monofilaments and they are less susceptible to defects in the outer surface of the suture material acting as stress risers.^{4,37} The major disadvantage of multifilament sutures is their roughened surface results in a high coefficient of friction that leads to a high tissue drag.^{70,81} This is rectified by some manufacturers with the addition of a polymer coating to the suture material which reduces the coefficient of friction and so improves the tissue drag of the suture.^{30,57} The consequence of reducing the multifilament suture materials coefficient of friction is that its KHC will also be reduced and so knots require more throws to be secure.⁵⁷ In contrast, although monofilament suture material has a very smooth surface and so a low coefficient of friction it undergoes plastic deformation when placed under tension in knot construction. This flattens the suture strands against one another and so there is a large strand on strand contact surface area which more than compensates for its inherently low coefficient of friction.⁵⁷ It follows that coating the multifilament suture material with different coatings will effect KHC.³⁷ As previously mentioned suture materials are coated with multiple different polymers, antibacterials and antiseptics in order to modify their properties and so this should be accounted for during knot selection and construction. The literature does not contain any direct comparisons for the KHC of coated and uncoated absorbable multifilament suture materials or any information regarding how differently coated suture materials may interact with media present at the surgical site and what impact that may have on their KHC.

Short term media exposure can affect the KHC of suture material and so the conditions in which a suture is tied should be accounted for by the surgeon. When exposed to physiologic and pathologic conditions for extended periods of time the tensile strength and consequently the KHC of suture materials is generally reduced. This is especially evident in septic or contaminated conditions and alkalotic conditions. Of all the suture materials challenged, polydioxanone consistently performed well when compared with other absorbable suture materials and so should be considered a preferred option when such conditions are encountered. Coating suture multifilament suture materials augments their properties at the cost of reducing their KHC. The biomechanics of how short term media exposure or coating of suture materials causes the observed changes in KHC reported is not fully understood. The literature lacks explanation as to why some reports show improvements in KHC while others document reductions in KHC.

Methods of evaluating the mechanical properties of suture materials and knots.

Strands of material have been analysed and tested in order to determine their mechanical and chemical characteristics for over a century. Many university engineering departments have laboratories dedicated to fiber and polymer research. One facet of this research in this field is that of medical grade suture material. The following section of this review outlines the various methods in which suture materials have been tested and analysed and how these methods have evolved.

The twist test

It was realized early in the study of surgical knots and their properties that the frictional properties of the suture material used to tie the knot had a significant effect on knot security.^{72,82} In 1985 Gupta et al. developed a methodology for testing the frictional properties of suture materials.⁷⁰ The apparatus involves twisting one strand of suture around another, simulating the first throw of a knot (Figure 2.1). The apparatus employed uses 2 strands of suture material, at one end they are both attached to a load cell, they are then threaded around two pulleys before being twisted on each other a predetermined number of times, finally each suture is attached to a variable load via another set of pulleys. The load on the strands of suture can then be altered by the operator. The data collected by the load cell in response to a varying weight is used to calculate the coefficient of friction between the two strands placed in the apparatus. They used this testing method to evaluate the frictional properties of eight suture materials. They found that the coefficient of friction is not a material constant but that it is dependent on a number of factors including: The applied tension on the sutures, the method of suture material construction and the suture material itself.⁶⁹

The finding that the coefficient of friction was not constant and not simply determined by the suture material itself poses the question: How might the coefficient of friction change when exposed to different conditions? The same group of investigators designed a study in an attempt to answer this.⁶⁹ They investigated the effects of lubrication on the frictional properties of suture materials.⁶⁹ They evaluated the suture when exposed to two different lubricants; a saline solution and a concentrated glycerin preparation. The twist test method

was used evaluate the effect either of these lubricants had on eight different suture materials. They found that once exposed to lubricants the suture materials exhibited higher coefficients of friction. The authors describe two different mechanical scenarios which may explain why exposing suture material to lubricants may increase the coefficient of friction exhibited. These are referred to as the “boundary” and “hydrodynamic” states and have already been explained in this review.⁶⁹

The twist test used by the authors in the two mentioned studies provided a consistent and reliable measure of the frictional properties of suture materials and could be used with an Instron testing device. These instruments are still used in materials testing and fiber analysis. The method was modified and adapted from an earlier study published by Taylor et al.⁸³ Interestingly that study also found that once exposed to serum sutures displayed an increased friction. Since the publication of these studies in the mid 1980s very little further work has been performed directly assessing the effect of lubrication or media exposure on the frictional properties of un-knotted suture material.

Single cycle to failure tensile testing

Single Loop

In order to compare the strengths of various knotted suture materials and various knot types a consistent, replicable and reliable system of testing needs to be in place. Single cycle to failure linear tensile testing of a single knotted loop of suture material is the most commonly performed mechanical test used in the surgical suture literature. Modern investigations

generally involve the use of an Instron or similar linear materials tensile testing machine to perform these tests, however before the advent of these advanced machines various linear distraction apparatus were used.

Single cycle suture material testing was initially performed using two different methods. In 1971 Herrmann used a method termed the “loop” method to determine knot security. A loop of suture material was tied around a cylinder in order to make it of standard circumference and then placed between two hooks which were then distracted from each other at a predefined rate.⁷² When this system is used the force at failure is equal to twice the KHC of the knot as there are two strands of suture between distraction points (Figure 2.2).

The other method of suture testing was also initiated in the 1970s and referred to as the “single strand” method. Holmlund et al initially describe the “single strand” method.⁸⁴ It is a modified version of the “loop” method in that as previously described a single strand of suture is knotted around a cylinder, however once this is created it is then cut and each end of the knotted strand is secured in a fashion allowing linear distraction of the strand (Figure 2.3).⁸⁴ This method measures the KHC of the knot directly. These methods as well as modified versions of these methods have been used by most researchers when a single cycle to failure system has been employed. This has allowed comparisons between various studies with similar methodology as well as the evolution and perfection of the testing methodology over time.

The first large investigation of knotted suture material was performed by Tera et al in 1975.⁵⁰ It investigated the knot security of 12 different knots tied with 12 different suture materials. The method employed to perform this testing was essentially the “loop” method. The investigators constructed an apparatus to perform the testing that used a dynamometer to measure the tension (Figure 2.2). The knotted suture loop was distracted at a rate of 1mm/sec until failure.⁵⁰ This study was also the first to develop a system of nomenclature for describing flat knot combinations (Figure 2.3)⁵⁰. The system indicates the number of twists the suture ends make with each other in each throw by means of Arabic numerals. The throws are then separated by either an “=” or an “X”. The “=” indicates that the strand enters and leaves the knot on the same side of the loop formed by the other strand. The “X” indicates that the strand enters the knot and leaves the knot on opposite sides of the loop formed by the other strand, i.e. a granny knot. This system has been subsequently used in other studies however has not become common place in relevant literature.^{50,75,85} Trimbos et al. also investigated the properties of surgical knots using the “loop” method however they included sliding knots in their comparisons and so followed on from Tera et al. by proposing a coding nomenclature for describing sliding knots.^{38,73} The difference in the sliding knot coding is that they are described based on the way they were formed rather than their appearance. “S=S” describes a knot in which each throw is turning in the same direction around the axial strand, while “SXS” describes a knot in which each throw is turned in the opposite direction from the previous.³⁸ The authors of both studies identify that an advantage of the loop method is that it negates the need to come up with a full proof, reliable method of securing the ends of the suture strand within the testing apparatus.⁵⁰

One of the major draw backs of the “single strand” methodology of suture testing is caused by the strand clamp interface. Due to local stress concentration at the strand clamp interface results can be hampered or falsely skewed by grip or clamp induced failures. A solution to this problem was reported by Chu in 1981, who reported the use of yarn clamps which spread the clamping force over a length of the sample and therefore reduce the local stress concentration (Figure 2.3).⁸⁶ This report is also one of the first to mention the use of an Instron materials testing machines or tensometers (Table Model TM, INSTRON, Norwood, MA). This study did not investigate knotted suture material; however, the introduction of yarn clamps was significant in the evolution of suture testing. The group went on to further investigate how exposure to conditions of varying pH effected the breaking strength of the same eight suture materials as previously tested, and again employed the same yarn grips in their testing apparatus.⁷⁶

Published only a few years later was another report that detailed a different method of evaluating the tensile strength of un knotted suture materials. Von Fraunhofer et al. published two reports evaluating the tensile strength of different gauges of 5 commonly used suture materials using a “cleat jig” (Figure 2.4).^{51,52} Using this method the strand ends were secured by wrapping them around cleats. The suture strand was then distracted at a rate of 50mm/min. This research group also used a different tensometer referred to as the Unite-O-Matic FM-20 universal testing machine. (United Calibration Corporation, Garden Grove, CA). The same testing method and apparatus was used in both reports published by the group, however no mention of the “cleat jig” method of tensile testing has subsequently been mentioned by surgical suture testing literature.

A report on the assessment of surgical sutures and knots in 1995 was one of the first to use a modified version of the “single strand” method.⁵⁶ In this modified testing method, a knot was tied around a steel bar secured in the lower grip of the testing apparatus and the free end was then clamped in the upper jaw of the tensometer. This group again opted to use an Instron materials testing machine to distract the strand at 300mm/min (5mm/sec), however unlike Chu they did not employ the use of yarn clamps on their upper clamp.⁵⁶ This modified “single strand” method of knotted suture linear testing has been employed in multiple studies subsequently.

In 2002 Schubert et al. reported on the mechanical properties of surgeon’s, square, granny and sliding knots in 4 different suture materials regularly employed in human gynecologic surgery. They used the coding system detailed by Tera and Trimbos to explain the knot combinations tested and also used a “loop” method for their testing.^{38,50,87} The knotted suture loops were tested with an Instron Materials testing machine. An initial load of 0.2N was placed on the loop to remove any slack in the testing system and then the loop was distracted by the apparatus at a rate of 5mm/min.⁸⁷ Innovatively, this study detailed how the knotted suture loops were placed in 0.9% saline in order to “wet” the knot in order to more closely simulate in vivo conditions.⁸⁷ This study was also one of the first to cut the free ends of the knot to 3mm so that if the knot slipped by more than 3mm knot failure occurred. This has become standard practice in knotted suture material testing in the more modern literature.⁸⁷

More recently Mulon et al. also choose a “loop” method to investigate the mechanical properties of 6 different knots, citing that they believe it to be more representative of the in vivo situation than a linear model. The knots were tied using three different suture materials commonly used in large animal surgery.⁴⁷ They evaluated 6 different knotting methods including, square, surgeon’s, sliding half hitch and some novel self-locking knots. One of the knots tested was a clamped surgeon’s knot. They determined that when using polydioxanone, clamping the first throw of the suture does effect the final knot security, however this is not the case when polyglactin was used.⁴⁷ Low friction plastic pulleys were used to hold the loop in place. This group of investigators used a servohydraulic mechanical testing machine (858 Bionix Test System, MTS, Eden Prairie, MN) to perform the distraction. The pulleys were distracted at a rate of 100mm/min until failure of the knot. These investigators also employed the use of a high speed digital video camera in order to record the mode of failure of the knot, as a result they were able to determine that all but 2 of 270 knots tested failed at the knot.⁴⁷ The authors commented that the single cycle high distraction rate load to failure was intended to mimic the acute loading that suture being used to close the equine linea alba might encounter when the horse recovered from anesthesia after abdominal surgery.⁴⁷

In 2010 Schaaf et al. used a similar testing technique to Shaw et al. in order compare Aberdeen knots to square knots when exposed to both plasma and fat.^{28,56} Here the “single strand” method was modified as the knot to be tested was tied around a polished steel bar at the base of the apparatus while the free end was attached at the proximal clamp (Figure 2.5).²⁸ The modification came in the attachment method of the free end to the proximal

clamp. The free end was fixed between two rubber pads using instant cyanoacrylate, this was then held in place with a hydraulic clamp. The rubber insert aimed at reducing any focal stresses generated by the strand clamp interface.²⁸ These investigators also used an instrumented needle holder capable of measuring the load placed on every throw of the knot allowing each throw to be tied with a standardized tension. They also used an Instron materials testing machine (Instron 5560 universal testing machine, Norwood, MA) to perform the strand distraction at a rate of 50mm/min until failure. A catching system was also placed around the steel bar where the knot was tied in order to facilitate knot retrieval and allow identification of the mode of failure of each knot.²⁸

Recent literature includes multiple studies that use the “loop” method for linear single cycle to failure testing.^{10,53,60} The majority of the studies published in the more recent literature have used one of the Instron universal materials testing machines to perform the distraction. Notably a study in 2011, from the human literature, used a different tensometer the exact model of which was not identified within the manuscript.⁶⁰ This study also used a distraction rate of 5mm/min. Fierheller et al. also used a modified “loop” model to test 4 different absorbable suture materials commonly used in large animal surgery.¹⁰ They placed the loop of suture around a metal pin fixed at the base of the apparatus as has been previously described. However, in their method they placed the loop through a section of equine linea alba. The linea alba section was then secured in the upper grip of an Instron materials testing machine using a “U” shaped flat jawed hydraulic vice and the system was distracted at 100mm/min. This report was the first report to focus on both knot security but also how the knotted suture interacted with the linea alba.¹⁰ A recently published study focusing on the

knot security of laparoscopic knots also used an Instron materials testing machine to load knots to failure using a “loop” method.⁵³ The distraction rate used in this study was 0.2mm/sec.

Single cycle to failure tensile testing remains the most commonly performed laboratory study used to evaluate the mechanical properties of knotted suture material. The evolution of this process has provided invaluable information to surgeon’s both in the veterinary and human medicine. Modifications to the initial “loop” and “single strand” methods have made the tests a more accurate assessment of the knotted suture when in vivo. This review will go on to review single cycle to failure testing of suture material when a continuous pattern is analyzed.

Continuous Pattern

A number of self-locking knots including the Aberdeen knot, the half-blood and the square knot were analyzed as part of an intra dermal continuous pattern used to close a defect in porcine skin.⁵⁹ The defects were all 4cm long and 4 bites of tissue were included in each continuous pattern. The skin samples were then cut so that they were held together only by the suture line. The samples were stored frozen in saline and allowed to return to room temperature prior to testing. The samples were secured in an Instron materials testing machine using squeeze clamps that were wider than the samples by 2 cm so as to distribute the load evenly along the suture line. The clamps were distracted at a rate of 100mm/min until the specimen failed.⁵⁹ This system was one of the first to describe testing knotted suture

material as a continuous pattern in tissue. Although the system is simply a modification to the single cycle to failure tests of either the “loop” or the “single strand”. The study design is far more realistic test of a suture line.

In 2015 Regier performed a similar study to the previously mentioned one by Richey et al with a few differences.^{59,68} They used canine skin instead of porcine skin and while they also investigated square and Aberdeen knots in a 4 bite continuous intra dermal pattern they did not include a self-locking start knot in their investigation.⁶⁸ Another notable difference was that they did not cut the skin either side of the incision line. In the Richey et al investigation the two pieces of apposed skin were held together purely by the continuous suture line where as Regier et al. left approximately 1cm of skin either side of the apposed incision line.^{59,68} This was done in order to accommodate the burying of the end knot by taking another bite of tissue with the working end of suture after the knot is tied, before the excess suture was cut.⁶⁸

Single loop testing after exposure

The advent of linear tensile testing models, including the “loop” model and the “single strand” model provided a reliable way of comparing suture materials and quickly led to multiple studies that investigated the tensile properties of both knots and suture materials. However, many of these studies acknowledge that this form of testing does not accurately simulate in vivo conditions. As a result, investigators started exposing suture material and

knots to media that might simulate the environment in which they might be tied or placed in order to determine what affect this had on the knot or sutures mechanical properties.

In 1989, Van Rijssel et al, designed a study to investigate the tissue reaction caused 2 different suture materials in rats.³³ As part of the study the loop holding capacity of the two suture materials was evaluated. The suture material was exposed to human serum for 15 minutes prior to knot construction.³³ Interestingly they comment that their experiment yielded loop holding capacities higher than those previously reported in when the suture was tested without exposure to any media.³³ In the same year another group published an investigation into the determination of the number of throws that was required to form a secure knot.⁵⁴ This study again exposed the suture to media prior to tying the knots in an effort to mimic the immediate in vivo effect of extracellular fluid on the physical properties of the suture material used. In this study canine serum was used as the media. The suture was exposed to the serum prior to tying the knots and the knots, once tied were then incubated in the serum for 24 hours prior to mechanical testing.⁵⁴

Campbell et al. also performed mechanical testing on knots that had been tied with suture exposed to equine serum.⁴⁸ In this study knots were tied on a specially designed jig from which they could be removed and incubated in equine serum for 24 hours prior to mechanical testing. Once placed between two metal rods that were then distracted from each other at a rate of 10mm/min until the loop failed.⁴⁸ A recently published article details an investigation that used a very similar technique of knot preparation in healthy canine plasma, however

instead of using a “loop” method to test the knots after 24 hours of incubation, these investigators cut the knotted loop of suture directly opposite the knot creating two strands either side of the knot of equal length, thereby converting to a “single strand” technique.³⁷ These strands were then placed in pneumatic air clamps and distracted at a rate of 20mm/min by an Instron materials testing machine.³⁷

Other studies including the one by Schiller et al. in 1993 have looked at the effect of contaminated, septic, acidic or basic media on both suture materials alone or knotted suture materials.⁷⁷ Schiller exposed the suture strands to either sterile or canine urine inoculated with *E. coli* or *P. mirabilis*, or canine urine that had been subjected to pH chemical modification with either hydrochloric acid or sodium hydroxide, for differing periods of time prior to mechanical testing.⁷⁷ This study employed a “single strand” method of testing and was performed by an Instron universal testing machine. The clamps were distracted from one another at a rate of 50mm/min. In order to cause the suture to uniformly fail in the middle of the two clamps a single square throw was placed in the suture line (Figure 2.7).⁷⁷ These investigators also wrapped the ends of the suture strand around stainless steel rods in order to prevent suture slippage through the Instron air clamps.⁷⁷ More recently a similar study used an almost identical methodology to investigate the effect on elasticity and breaking strength of synthetic suture materials, commonly used in equine surgery, when incubated in various equine physiologic and pathologic fluids.⁸⁰ These investigators comment that the single throw placed in the middle of the suture strand between the two air clamps dramatically reduced the number of suture failures at the strand clamp interface.⁸⁰

In 2007, Nichols et al. also exposed small gauge suture material to media with an altered pH or contaminated with bacteria prior to mechanical testing in order to determine the effect the effect of such conditions on the breaking strength of the several different suture materials.⁷⁹ The incubation time ranged from 7 days to 21 days prior to testing. The strands of suture were tied together so they could be placed over two metal cylinders and tested using a “loop” method by an Instron universal testing machine. The metal cylinders were distracted at a rate of 60mm/min until failure.⁷⁹

The most recent report to detail an investigation into the mechanical properties of knotted suture material concentrated on large gauge suture materials primarily used in equine surgery for closure of the linea alba following exploratory celiotomy.³¹ The details of the suture investigated and media used has been previously detailed in this report. The investigators in this study however designed a novel testing mount for use with an Instron universal testing machine. The “split jaw” mount is able to test the suture using a modified “loop” test technique (Figure 2.8).³¹ The advantage of the split jaw is that it allowed transfer of knots previously tied on a plastic knot tying mount of the exact dimensions of the split jaw. The knots tied on the mount were then able to be incubated in an assigned media for a designated period of time prior to transfer to the split jaw mount for mechanical testing.³¹ A 1kN load cell was used to record the data as the split jaws distracted the suture material at a rate of 6mm/min.³¹

As has been detailed there are many reports looking into the effect of varying types of media exposure and varying durations of media exposure on the mechanical properties of both knotted and unknotted suture materials. The goals of such work is in determining the effect that *in vivo* conditions have on the suture materials placed in surgery, so that more accurate and informed decisions can be made with regards to which type of suture and which type of knot are appropriate in a given situation. Although this information has improved the surgeon's knowledge of the biomechanical properties of suture materials it is with the understanding that the test conditions used to evaluate these properties are still not an accurate representation of the force imparted on a line of suture material *in vivo*.

Inflating bladder

The importance of examining and understanding the forces placed on an abdominal incision and so the sutures used to hold it in apposition has been recognized by surgeons since the late 1940s. Publications in human medical journals exploring muscular tensions and intraperitoneal pressures date back to 1944.⁸⁸⁻⁹⁰ In 1948 Haxton passed inflatable balloons into the abdomen of patients with abdominal incisions through an indirect inguinal hernia sac. The balloons were then filled with sterile water and connected to a manometer. The intra-abdominal pressure was then measured using this system while patients were asked to defecate.⁹⁰ Drye used a similar methodology to measure intra-abdominal pressures in patients while coughing.⁹¹ In 1965 Haxton expanded on his previous work by performing a larger study using human cadavers. In this work he placed an inflatable bag into the peritoneal cavities of cadavers with ventral midline incisions. The ingress tubing of the bag was placed through a separate stab incision in the side of the abdomen. He used this experimental setup

to test the bursting pressures and mode of failure of multiple different closure techniques, examining different gauges of silk and nylon suture material.⁹²

Further investigation into incisional bursting strength has since been performed in laboratory animals. Poole et al. used rats to evaluate ventral midline incisional bursting strength when closed with Dacron in either simple interrupted, cruciate or simple continuous suture patterns.⁹³ A similar investigation was performed by Rodeheaver et al, this time to evaluate the incisional bursting strength of a novel monofilament non absorbable suture material. Both of these studies used female spayed rats.⁹⁴ Once euthanized the rats had an inflatable latex balloon on the end of a polyvinylchloride cannula, placed through a stab incision in the cranial vagina. The balloon could then exert a measurable amount of abdominal pressure on the ventral midline incisions.⁹⁴ This model has been used by other investigators to evaluate various different ventral midline closure techniques in rats.⁹⁵⁻⁹⁷

Although closure of a ventral midline incision with a technique and suture that is able to withstand the stresses put on it by the patient is important in humans and small animals, it is insignificant when compared with its importance in the equine patient. More recently some of the previously described models have been adapted for use in the equine cadaver. In 1999 Magee et al. used a similar method to that described by Haxton in the 1940s to evaluate two different suture patterns placed with 3USP Polyglactin 910 in a 25cm long equine ventral midline incision.⁹⁸ Due to the size of the equine abdomen a large 200L polyurethane bladder was used. The bladder had an ingress tube that originated at an air compressor and was

moderated by a flow gauge so that it delivered air at a rate of 40L/min. It also had egress tubing that terminated at a pressure transducer linked to a digital display to enable data collection. The ingress and egress tubes were passed through stab incisions through the body wall on either side of the abdominal cavity between the 14th and 15th ribs. A large nylon strap was also placed around the caudal abdomen just cranial to the pelvis to prevent herniation of the abdominal contents through the inguinal fascia (Figure 2.9).⁹⁸ The inflatable bladder was then distended, inducing abdominal pressure until the ventral midline closure failed.⁹⁸ The abdominal bursting pressure and mode of failure at the incision was recorded for analysis.

This model has since been used by the same research group and others to evaluate various suture materials, suturing techniques and knot types when closing the equine linea alba.^{25,26,99} Most recently this model was used to compare a new large gauge braided suture material (7 USP polydioxanone) designed for large animal surgery, in particular closure of the equine linea alba.²⁶ The same group also used this model to evaluate the differences in bursting strength of a ventral midline closure with a right ventral paramedian closure.²⁵ They determined that the ventral midline closure is stronger than a right ventral paramedian closure. The right ventral paramedian incision is occasionally used in equine celiotomy if a repeat surgery is required so as to avoid entering the abdomen through a healing or compromised incision.²⁵ Additionally, there are reports indicating that a right ventral paramedian incision is less prone to incisional complications in the post-operative period.¹⁰⁰

The inflatable bladder model is able to more accurately simulate the three dimensional forces placed on both a suture line and knot than the “loop” and “single strand” models. It is also able to simulate the large sudden force that the equine ventral midline closure must withstand when a horse recovers and moves from lateral recumbency to a standing position following anesthesia for abdominal surgery. However, it like the other models described, is unable to simulate the cyclic loading incurred by the suture line and knot until the linea alba is healed.⁵

Cyclic loading

Cyclic loading has been performed on orthopedic metallic implants designed for large animal use extensively.^{101,102} Recently in the human field cyclic loading of suture material constructs used to replace ligaments and tendons when reconstructing or repairing damaged high motion joints has become common place.^{103,104} In the field of veterinary medicine, cyclic loading studies have been performed on suture materials used for extra capsular stabilization of the canine cruciate ligament.¹⁰⁵⁻¹⁰⁷ Cyclic loading has also been performed on suture materials used in equine upper airway procedures such as the tie back and tie forward.¹⁰⁸⁻¹¹⁰ As the airway is constantly moving and under a number of three dimensional forces the introduction of dynamic models on which cyclic loading of the suture implants can be performed has yielded valuable information.¹⁰⁸⁻¹¹⁰

Cyclic loading has also been performed on laparoscopic suture loops used in both human and veterinary surgery. Fugazzi et al. performed cyclic loading using a “loop” model on four different knot types tied with either USP3-0 polyglactin 910 or USP3-0 polydioxanone.⁵³

The suture loops were placed between two metal cylinders attached horizontally to an Instron universal materials testing machine. A preload of 7N was applied to the loop to negate any slack. The loop was then loaded between 7 and 20N for 30 cycles at a rate of 3.5N/s.⁵³

As far as the author is aware no cyclical loading experiments have been performed on suture materials or knots used to close the equine linea alba, however this fact is regularly mentioned in the relevant literature. Although the previously mentioned methods of evaluating knot strength and suture strength are able to indicate how well a ventral midline closure will tolerate a single, acute load, such as that experienced by the equine patient following anesthetic recovery, they do not give an indication as to how they will maintain their strength after multiple cycles are applied during the post-operative period. Clinical experience has indicated that the large gauge suture materials that are commonly used to close the equine linea alba, such as 3USP polyglactin 910 and 2USP polydioxanone, are up to the task, but is it too much? Could a smaller gauge suture be used that may reduce the inflammatory reaction caused by suture placement.³³ There is currently no model published that can simulate the *in vivo* conditions during, immediately after in recovery and in the post operative period, so for the time being subjecting the suture materials used, the suture patterns used and the knots used to multifactorial rigorous mechanical and biomechanical testing is imperative.

Objectives

Recently, research performed in our laboratory determined that the optimal number of throws needed when using 2 USP polydioxanone, 2 USP polyglactin 910 and 3 USP polyglactin 910 suture, to tie a secure pattern starting knot was 6 throws for both a surgeon's and square knot when tested in dry conditions using a linear, single cycle to failure, modified "single strand" method.²⁷ The same research also determined that pattern-ending surgeon's and square knots in a continuous suture line were found to be weaker than pattern-starting knots with respect to throw number.^{27,111} Both 3 USP polyglactin 910 and 2 USP polydioxanone are commonly used suture materials in equine abdominal surgery, but have yet to be subjected to materials testing after exposure to biologic media.²⁷

The Aberdeen knot is a self-locking knot, shown to have superior mechanical properties to surgeon's and square knots.^{27,28,65} Self-locking knots have superior security to surgeon's and square knots, demonstrate less tendency to slip, and are also smaller and lighter leaving less foreign material in the incision line.⁵⁹ In dry conditions using 3 USP polyglactin 910 and 2 USP polydioxanone, the Aberdeen knot exhibited superior mechanical properties to both surgeon's and square knots.²⁷ However, it is known that the physiological conditions encountered by suture materials in the patient affects their biomechanical properties.¹¹²

Previous publications have noted a significant effect of lubrication on the frictional properties of suture.^{69,73-75,113} In small gauge suture (2-0 USP polydioxanone), the relative

knot security (RKS), defined as the knot strength expressed as a percentage of the suture's tensile strength, of Aberdeen knots was found to be significantly increased compared to square knots when exposed to plasma and fat.²⁸⁻³⁰ Comparisons with surgeon's knots were not performed in this study.^{28,29} At the time of this report, large gauge suture has yet to be subjected to materials testing after exposure to biologic materials that simulate the conditions found in the equine ventral midline surgical field.²⁷

The purposes of this study were twofold: Firstly, to determine, at each end of the suture line whether square or surgeon's knots delivered the highest knot holding capacity (KHC) when tied with media exposed 3USP polyglactin 910 or 2USP polydioxanone. Secondly, to determine whether the pattern ending square, surgeon's or Aberdeen knot delivered the highest KHC when tied with either media exposed 3USP polyglactin 910 or 2USP polydioxanone.

As dictated by the purposes of this study two experiments were performed. The first experiment (Part 1) intended to compare the KHC of both pattern starting and ending surgeon's and square knots tied with 3USP polyglactin 910 and 2USP polydioxanone exposed to 4 different media, or kept dry. The 4 media used were chosen as they are all commonly present in the equine abdominal surgical field. The second experiment (Part 2) intended to compare the KHC of pattern ending surgeon's, square and Aberdeen knots tied with 3USP polyglactin 910 and 2USP polydioxanone exposed to 4 different media or kept dry.

Hypotheses

This study hypothesized the following:

- 1) The KHC of knots tied using suture material exposed to media, including a balanced electrolyte solution, equine serum, 1% carboxymethylcellulose (CMC), or equine abdominal fat, would have a higher KHC than knots tied with dry suture.
- 2) Start surgeon's and square knots were hypothesized to have a higher KHC than end square and surgeon's knots.
- 3) Aberdeen knots would demonstrate a higher KHC than square and surgeon's knots, regardless of the media they are exposed to.
- 4) Regardless of knot configuration and number of throws, we hypothesized that knots performed with the larger gauge, multifilament suture 3 USP polyglactin 910 would show a higher KHC than those tied with the smaller gauge, monofilament 2 USP polydioxanone.^{10,51,52}
- 5) That exposing knots to the various media would increase their weight and volume, resulting in an increased knot size.

Materials and Methods

All equine cadaver tissues were obtained from cadaver horses euthanized for a separate, unrelated study that was evaluated and approved by the University Institutional Animal Care and Use Committee. Testing of the knots was performed in a controlled laboratory environment of 21⁰C and 65% humidity (ASTM D1776-15-Standard Practice for Conditioning and Testing Textiles, <http://www.astm.org/Standards/D1776.htm>). To ensure all the suture material was of similar strength, one suture from each box was subjected to a single cycle-to-failure test, with a distraction rate of 100 mm/minute and a 21N +/- 0.01% static load. A static load of 21N was previously calculated in our laboratory by averaging the tension placed by three surgeons on the suture when tying knots.²⁷ For this single cycle-to-failure test, the load device consisted of two clamps: one at the proximal end and one at the distal end of the suture. No knots were tied at this stage. If the suture had a tensile strength outside of the acceptable range (less than 90% of the mean tensile strength of all the suture tested), the box of suture that strand originated from was discarded.

For testing of each knot configuration, a new packet of suture was used for each knot. Knots were either tested dry or exposed to one of four media. Immediately before the knots were tied, the suture was removed from the packet and exposed to nothing (the dry control) or bathed in one of four media for 15 minutes to simulate *in vivo* conditions: a balanced electrolyte solution (Normosol R, Abbott Laboratories, North Chicago, IL), equine serum, 1% sodium carboxymethylcellulose (CMC, Spectrum MFG Corp, Gardena, CA), or equine

abdominal fat. The serum and fat were acquired from healthy horses enrolled in a separate study that were euthanized with intravenous magnesium sulfate that was titrated to effect, while under general inhalant anesthesia. The serum and fat were obtained from two separate horses and pooled for storage. To obtain serum, blood was drawn from the jugular vein using a 14 gauge needle and 60 mL syringe and placed into 50 ml conical centrifugation tubes without coagulant. The samples were allowed to clot for 30 minutes at room temperature (21 °C), and then centrifuged at 2500 rpm for 15 minutes to separate the serum from the cells. The serum was then stored at -20°C, and allowed to return to room temperature before suture immersion. The fat was harvested using sharp dissection from the ventral abdomen accessed via a ventral midline incision, pulverized using a handheld macerator (model 59762, Hamilton Beach, Southern Pines, NC) and stored in a similar fashion.

Three different knot types were tested using a Universal materials testing machine (INSTRON, Norwood, MA) (Figure 3.1). The surgeon's and square knots were tested with 5, 6, 7 or 8 throws, while the Aberdeen knot was tested with 3, 4, 5 and 6 throws each with 1 turn. The first throw of the surgeon's knot was a double, overhand throw, while the remainder of the throws consisted of square knots. These combinations were selected for testing from data obtained from previous experimental data that determined surgeon's and square knots with 6 or 7 throws, and Aberdeen knots with 4 throws and 1 turn, demonstrated the highest KHC in dry conditions.²⁷ Both pattern-starting or "start" knots and pattern-ending or "end" knots were tested (Figure 3.2). Start knots were tied with two free ends of suture around a cylindrical steel rod resulting in two free ends, one of which simulates the

working end going towards the continuous pattern. End knots were tied with the working end of the suture and a loop around the steel rod. These resulted in a free end and a loop. Aberdeen knots are constructed by taking the loop created by the last bite of the suture line and passing a further loop formed by the working end of the suture through it (Figure 3.3). This process is considered a single throw and can be repeated at the surgeon's discretion. It is finished by passing the working end through the previously formed loop; this is called the turn.⁶⁵

Half of the knots were constructed with 3 USP polyglactin 910; the other half were constructed with 2 USP polydioxanone. Each suture, knot type, throw combination and media exposure was tested 10 times resulting in a total of 2000 knots being tested. All knots were tied with the suture in place on the materials testing machine. All free ends were trimmed to 3mm in length. Surgeon's and square knots were tied using Mayo-Hegar 8" needle drivers, while Aberdeen knots were tied by hand.

The materials testing machine consisted of an upper and lower grip. The surgeon's, square and Aberdeen knots were tested by mimicking the forces applied to the knot *in vivo* by the preceding or following suture pattern and the initial or final loop of suture. The loop was placed around a cylindrical metal rod attached to the lower grip of the testing machine, while the end simulating the suture from the continuous suture line was clamped by the upper grip of the apparatus (Figure 3.3).

All of the knots were tied by the same investigator (MC). The initial distance between the metal rod and the upper grip was 10 cm and a preload of 21N was applied across the knot by the testing machine once the knot was tied to remove any slack in the suture.²⁷ To test the knot strength, the loading apparatus was distracted at 20 mm/min, applying tension across the knot until suture failure occurred. Failure was considered either complete fracture of the suture material or slippage of the knot by 3mm or greater.⁵³ The knot holding capacity (KHC in N), defined as the maximum load to failure when tension is applied to a knotted suture material, was obtained by the materials testing machine and recorded using INSTRON Bluehill 2.24.787 software (Norwood, MA).³⁰

To determine knot size after exposure to the different media, 5 knots of each knot configuration (1000 knots total) were tied separately for volume and weight calculations. The suture used was again exposed to the simulating media for 15 minutes prior to tying. In addition, both tag ends were cut to 3mm in length so that they could be weighed to a resolution of 0.1mg (Mettler AE 163, Mettler Direct, CA). Once tied, the height and diameter of the knots were recorded using a digital micrometer (Digital, Carbon Fiber Caliper, Ted Pella Inc, Redding, CA) to a resolution of 0.01mm. Volume (V , mm³) was approximated using the formula $V = \pi r^2 h$.

Statistical analysis was performed using commercial statistical software (JMP Pro 11.0.0, SAS Institute Inc. NC). Normality of the data was determined by an Anderson-Darling test. Parametric testing was performed for normally distributed data using separate analyses of variance (ANOVA), followed by Tukey's post hoc analysis for those comparisons with significant differences, to evaluate the mean difference in KHC between the number of

throws, the suture type, suture size, the media exposure, and the type of knot. Significance for this study was set at $P < 0.05$.

Results

Batch testing of the suture material.

Analysis of a single strand from each box of suture material subjected to a single cycle-to-failure test in linear fashion found all suture material tested to be within 10% of the mean tensile strength calculated for both 2USP Polydioxanone and 3USP Polyglactin 910. None of the boxes of suture material were discarded from the study.

Part 1

The effect of media exposure on KHC of:

Start knots tied with 3 USP polyglactin 910

Overall, start knots tied using 3 USP polyglactin 910 exposed to media had a significantly higher KHC than those tied in dry conditions ($P=0.0008$) (Figure 4.1). However, media exposure negated the effect that increasing the throw number would be expected to have on the KHC of surgeon's and square start knots tied with 3 USP polyglactin 910. A significant increase in KHC was only identified between dry surgeon's start knots tied with 5 throws and those tied with 6 throws ($P=0.0095$). In all other comparisons of media exposure and throw combinations, no significant differences in KHC were identified ($P>0.056$).

Start knots tied with 2 USP polydioxanone

Start knots tied using 2 USP polydioxanone exposed to media had a significantly higher KHC than start knots tied in dry conditions for all 4 throw combinations. When evaluating only surgeon's start knots, when tied with 5 throws, knots composed of suture exposed to

CMC, Normosol, equine serum and equine abdominal fat had a significantly higher KHC than that of knots tied in dry conditions ($P<0.0013$). When tied with 6 or 8 throws, significant increases in KHC were identified between dry surgeon's start knots and surgeon's start knots tied with 2 USP polydioxanone exposed to CMC and equine abdominal fat ($P<0.03$). When tied with 7 throws, significant increases in KHC were seen between dry surgeon's start knots tied using 2 USP polydioxanone and those exposed to CMC, BES and equine abdominal fat ($P<0.0065$).

In comparison to surgeon's knots, when square start knots were tied with 5 throws, 2 USP polydioxanone exposed to any of the four media had a significantly increased KHC when compared to those tied in dry conditions ($P<0.0003$). When tied with 6 or 7 throws, significant increases in KHC were identified between dry square start knots and those tied exposed to CMC, BES and equine abdominal fat ($P<0.032$). When tied with 8 throws, significant increases were seen between dry square start knots and those exposed to CMC and BES ($P<0.0026$). Overall, start knots tied using 2 USP polydioxanone exposed to media had a significantly higher KHC than those tied in dry conditions ($P<0.0001$) (Figure 4.1).

End knots tied with 3 USP polyglactin 910

Similar to start knots, end knots tied using 3 USP polyglactin 910 exposed to media had a significantly higher KHC than those tied in dry conditions ($P<0.0001$) (Figure 4.1). When 3 USP polyglactin 910 was used in the construction of surgeon's end knots, significant increases between dry and media exposed knots were identified at 3 throw combinations.

Specifically, when surgeon's end knots were tied with 5 or 6 throws, suture exposed to any of the 4 media had a significantly increased KHC when compared to those tied in dry conditions ($P<0.002$). When surgeon's end knots were tied with 7 throws a significant increase in KHC was identified between dry and suture exposed to equine serum ($P=0.024$). However, when surgeon's knots were tied with 8 throws no increases in KHC were identified between dry and media exposed knots.

Regarding square end knots using 3 USP polyglactin 910, significant differences were noted between dry and media exposed knots tied for all throw combinations. When square end knots were tied with 5 throws, suture exposed to any of the 4 media had a significantly increased KHC when compared to those tied in dry conditions ($P<0.0001$). When square end knots were tied with 7 throws significant increases in KHC were identified between dry and suture exposed to CMC and equine serum ($P<0.02$). When square end knots were tied with 8 throws significant increases in KHC were identified between dry and suture exposed to CMC and equine abdominal fat ($P<0.02$). However, when square end knots were tied with 6 throws no significant an increase in KHC was identified between dry and suture exposed to media ($P>0.3$).

End knots tied with 2 USP polydioxanone

In contrast to the findings for the end knots tied with 3 polyglactin 910, no significant differences in KHC were identified between dry and media exposed end knots tied with 2 USP polydioxanone ($P=0.1$) (Figure 4.1).

The effect of increasing throw number on KHC

Surgeon's end knots tied using 2 USP polydioxanone displayed no significant differences between dry and media exposed knots tied for any of the four throw combinations ($P>0.05$). Square knots showed similar findings barring one exception; when 2 USP polydioxanone was tied using 5 throws and exposed to CMC a significant increase in KHC when compared to the same knot tied in dry conditions was identified ($P=0.02$).

The number of throws on the knots tested demonstrated a ceiling effect for all combinations assessed. When start knots were tied using either 2 USP polydioxanone or 3 USP polyglactin 910 exposed to any of the four media, both surgeon's and square knots displayed no significant differences in KHC as throw number was increased from 5 to 8 throws ($P>0.14$). A significant increase in KHC was only identified between dry surgeon's knots tied using 3 USP polyglactin 910 with 5 throws and 6 throws ($P=0.01$).

When end knots were tied using 3 USP polyglactin 910 exposed to any of the four media, surgeon's knots showed no significant differences in KHC when the throw number was increased over 6 throws ($P>0.2$). Square knots tied with 3 USP polyglactin 910 exposed to any of the four media showed no significant differences in KHC when the throw number was increased over 5 throws ($P>0.07$). Both surgeon's and square end knots tied using 2 USP polydioxanone exposed to any of the four media showed no significant increase in KHC as throw number was increased over 5 throws ($P>0.2$). End knots tied in dry conditions

showed increases in KHC between 5 and 6 throws when surgeon's and square knots were tied with 3 USP polyglactin 910 and when square knots were tied using 2 USP polydioxanone ($P<0.02$). However, no increases in KHC were seen with either suture material used to tie start knots over 5 throws and end knots over 6 throws when suture was exposed to media ($P>0.07$)

The effect of suture material and knot type on start and end knot KHC

Knots tied using 3 USP polyglactin 910 were shown to demonstrate a greater KHC than those tied with 2 USP polydioxanone when both start and end knots were tested (Figure 3). The KHC of start knots tied with 3 USP polyglactin 910 (mean KHC = $101.6\pm 0.8N$) was significantly higher than that of start knots tied with 2 USP polydioxanone (mean KHC = $68.4\pm 0.8N$) ($P<0.0001$). Start knots were also found to have a significantly higher mean KHC than end knots ($P<0.0001$). Although surgeon's start knots had a mean KHC ($85.8\pm 1.2N$) higher than that of square knots ($84.3\pm 1.2N$) this difference was not of statistical significance ($P=0.4$). However, surgeon's end knots had a significantly higher KHC ($73.9\pm 1.0N$) than square end knots ($66.4\pm 1.0N$) ($P<0.0001$).

The effect of media on knot size.

Exposure of suture to either BES or equine serum tended to reduce knot weight, while exposure to CMC and equine abdominal fat tended to increase knot weight when compared to knots with the same number of throws tied in dry conditions (Figure 4.2). End knots were significantly heavier and larger in diameter than start knots ($P<0.0001$). Overall, pattern

starting and ending knots tied with 3 USP polyglactin 910 were significantly heavier and larger than start knots tied with 2 USP polydioxanone with the same number of throws ($P<0.0001$). Similar results were noted when comparing the type of knot and throw number. Surgeon's knots were significantly heavier and larger than square knots when both start and end knots were analyzed ($P<0.006$).

For both start and end knots, knot weight and knot volume increased with increasing throw number across all media and for both types of knot (Figure 4.2). The heaviest knot was a pattern ending surgeon's knot constructed with 8 throws and exposed to equine abdominal fat ($84\pm 1.6\text{mg}$). Both 3 USP polyglactin 910 and 2USP polydioxanone, exposed to BES and tied in either a surgeon's or square knot with 5 throws produced the lightest knots ($14\pm 1.7\text{mg}$). In regards to volume, the largest knot was pattern ending surgeon's knot with 8 throws tied using fat exposed 3 USP polyglactin 910 ($196.8\pm 5.4\text{mm}^3$). The knot with the lowest volume was a pattern starting square knot with 5 throws using dry 2USP polydioxanone ($28.5\pm 4.1\text{mm}^3$).

Part 2

No significant differences in KHC were identified between the knots tied with suture exposed to each of the 4 media with respect to suture type and knot type. As a result, the media exposed suture data was combined into a single group, termed "media exposed" for further comparisons. ($P<.0001$)

The effect of media exposure on the KHC of Surgeon's, square and Aberdeen Knots

Knots of the same type (surgeon's, square or Aberdeen), that were tied with the same suture material showed no significant difference in KHC when comparisons were made between the types of media exposure ($P < 0.0001$) (Figure 4.3). As the specific type of media did not have a significant effect on knot security, the media exposed suture data was combined into a single group, termed "media exposed" for further comparisons. The data was then analyzed according to knot type.

Surgeon's knots

No significant differences in KHC were identified between dry and media exposed surgeon's knots tied with 2USP polydioxanone, at any of the 4 throw combinations, ($P > 0.91$) (Figure 4.4). The KHC did not significantly increase as throw number increased.

For surgeon's knots tied with dry 3USP polyglactin 910, KHC significantly increased as the number of throws increased, until 7 throws were placed ($P < 0.04$). No additional increase in KHC was noted for dry suture with 8 throws. Media exposure significantly increased the KHC compared to dry knots, but only between knots with 5 and 6 throws (Figure 4.4) ($P < .0001$). Comparisons of surgeon's knots using media exposed 3USP polyglactin 910 suture showed KHC was not affected as throw number increased. ($P > 0.99$)

Square knots

No significant differences in KHC were identified, at any of the 4 throw combinations, between dry and media exposed square knots tied with 2USP polydioxanone ($P>0.25$) (Figure 4.5). The number of throws had no significant effect on KHC.

Square knots tied using dry 3USP polyglactin 910 showed a significant increase in strength when the number of throws increased from 5 to 6 throws ($P<.0001$). Further increases in the number of throws had no effect on KHC ($P>0.09$). The number of throws had no effect on square knots tied with media exposed 3USP polyglactin 910, and these knots were not different in KHC from dry knots with more than 6 throws ($P<0.023$).

Aberdeen

Aberdeen knots tied with either media exposed 2USP polydioxanone or 3USP polyglactin 910 had a significantly higher KHC than dry knots with respect to throw number (Figure 6) ($P<0.001$). Throw number had no effect on the Aberdeen knots, whether dry or exposed to media, demonstrating no significant increase in KHC as the throw number increased from 3 throws and 1 turn ($P>0.37$). (Figure 4.6).

The effect of suture material on KHC

Surgeon's, square and Aberdeen knots tied with media exposed 3USP Polyglactin 910 had a significantly higher KHC than their equivalents tied with media exposed 2USP

Polydioxanone ($P < 0.0001$) (Figure 4.7). Aberdeen knots tied with 3USP Polyglactin 910 displayed the highest KHC.

The effect of knot type on KHC

When knots were tied with either media exposed or dry 2USP polydioxanone, surgeon's knots had a significantly higher KHC than square knots and Aberdeen knots had a significantly higher KHC than both square and surgeon's knots ($P < 0.0001$) (Figure 4.8). Media exposure of 2USP Polydioxanone did not result in a significant difference in KHC when both square and surgeon's knots were tested. Aberdeen knots tied with media exposed 2USP polydioxanone had a significantly higher KHC than dry Aberdeen knots ($P < 0.0001$).

No significant difference was identified in the KHC of dry surgeon's and square knots tied with 3USP polyglactin 910, however dry Aberdeen knots tied with 3USP polyglactin 910 had a significantly higher KHC than the other two knot types ($P < 0.0001$). Exposing 3USP Polyglactin 910 to media resulted in an increase in KHC seen in all three knot types with respect to their dry variants ($P < 0.0001$). In summary, media exposure improved the KHC of surgeon's and square knots tied with 3USP polyglactin 910 and Aberdeen knots tied with either suture material and subjected to linear, single cycle-to-failure materials testing.

The effect of media exposure on knot volume

Aberdeen knots produced knots with lower volumes than both surgeon's and square knots (Figure 4.9). For knots of the same type and tied with same suture material, media exposure

caused a significant increase in knot volume ($P < 0.05$). However, Aberdeen knots exposed to media had significantly smaller volumes than both square and surgeon's knots exposed to media and tied with the same suture ($P < 0.0002$).

Discussion

Part 1

Previous reports have suggested that media exposure effects the mechanical properties of suture, including KHC and tensile strength, both positively and negatively, when tested in smaller gauge suture.^{28,59,74} The present study supports findings that show that media improves holding strength for the majority of the comparisons. Start knots tied using 3 USP polyglactin 910 and 2 USP polydioxanone and exposed to media had a significantly higher KHC than those tied in dry conditions. End knots tied using 3 USP polyglactin 910 exposed to media had a significantly higher KHC than those tied in dry conditions, however no significant differences in KHC were identified between dry and media exposed end knots tied with 2 USP polydioxanone. One explanation for the difference seen in strength of end knots exposed to media is the configuration of the end knot itself. Two USP polydioxanone, is a monofilament suture material that has a lower coefficient of friction and a higher stiffness resulting in a reduced surface area of suture contact within the knot.³⁰ The extra strand of suture incorporated into end knots as a loop also decreases the surface area of suture contact.^{54,59} These factors likely account for the reduced effect media exposure had on knots tied with 2 USP polydioxanone and pattern ending knots. Further testing of additional monofilament suture materials, including nylon, polyglecaprone 25 or polyglyconate, would be required to confirm this hypothesis.

A ceiling effect was noted regarding the number of throws and their effect on knot strength. For both pattern starting and pattern ending knots tied using 3 USP polyglactin 910 or 2 USP polydioxanone exposed to media, KHC did not increase significantly when performed with

over 5 throws for start knots and 6 throws for end knots. These results are in agreement with reports analyzing knot security using smaller gauge 0 USP suture materials exposed to 0.9% sodium chloride solution.⁶⁰ Importantly, these findings suggest maximum KHC can be reached with a single throw fewer than previously reported by our laboratory when the same start knots were tested in dry conditions.¹¹⁴ Reducing the number of throws needed to form a secure knot could reduce the amount of foreign material placed in the incision line. As suture can incite a foreign body reaction, a smaller knot should result in a smaller inflammatory reaction within the tissue.^{59,115,116}

As hypothesized, 3 USP polyglactin 910 demonstrated a greater KHC than 2 USP polydioxanone when both start and end knots were compared, which is consistent with similar previous findings in dry suture material by this laboratory and others.^{4,114} More specifically, 3 USP polyglactin 910 has been shown to exhibit a higher tensile strength than 2 USP polydioxanone.^{10,30,51} This result is not unexpected given that 3 USP polyglactin 910 is a braided multifilament suture one gauge larger than 2 USP polydioxanone, and considering that a suture strand's tensile strength is directly related to its cross sectional area.^{51,52} Although 2 USP polyglactin exists, this study was designed to analyze the most commonly used suture materials by colic surgeon's as well as the largest commercially available variants of each suture material in the United States. The results of this study suggest that 3 USP polyglactin 910 should be used for both start and end knots when closing the linea alba.

Similar to previous publications, start knots in both types of suture material and for different combinations of throws, showed increased knot security compared with end knots of similar configuration, similar to previous publications.^{28,54,114} It has been suggested this is due to the inherent risk of failing to grasp the center of the loop of suture when tying the end knot, and therefore placing unequal load on each throw resulting in a 'loose' knot.^{28,54,59} Alternatively, the extra strand of suture present in the end knot configuration may cause the opposing strands comprising the knot to have less surface area in contact with each other.^{54,59} A lower contact surface area would have a concentrating effect on the tensile load, meaning the knot would require a lower tensile load to fail when compared with a start knot which has a higher contact surface area. Regardless, these results imply that an end knot for a continuous pattern will require an additional throw for knot security.

Surgeon's knots were found to have a greater KHC than square knots when both pattern starting and pattern ending knots were analyzed. However, this finding was only statistically significant when pattern-ending knots were compared. As end knots may be inherently weaker than start knots, the greater opposing strand surface area in contact present in the surgeon's end knot when compared to the square end knot likely has a significant effect on KHC.⁵⁴ Most equine surgeon's prefer the surgeon's when starting and ending a continuous pattern to close the linea alba, due to the fact that there is often a large amount of tension in the opposing edges of the linea alba.^{1,31,47,117} The results of this study further support the use of a surgeon's knot rather than a square knot to both start and end a continuous suture pattern, in both dry and media exposed conditions.

Data collected during this study confirmed our hypotheses that knot weight and volume increased significantly as throw number increased, that end knots are significantly heavier and larger than start knots, and that knots tied with 3 USP polyglactin 910 are significantly heavier and larger than those tied with 2 USP polydioxanone. Interestingly, exposure to media did not always lead to an increase in knot weight when compared with dry knots. The lubricating effect of less viscous media such as equine serum and BES likely leads to a monolayer of media between the suture strands, reducing the suture's coefficient of friction.⁶⁹ This reduction in the coefficient of friction allows the same force applied to the suture strands, to construct a tighter knot using less suture material. This implies that knots tied in vivo may be smaller due to the conditions they are tied in, and therefore place less foreign material in the wound. Evaluation of knots tied in vivo would support this theory.

Part 2

Previous findings have determined that Aberdeen knots have a significantly higher KHC than both surgeon's and square knots when tested in dry conditions.²⁷ The aim of this study was to determine if this relationship held when tested in media representative of fluids that may be encountered in a surgical field, and quantify the effect these conditions had on a knot's mechanical properties. The results from this study show that media exposure can significantly improve the KHC of surgeon's, square and Aberdeen knots when compared to similar knots tied in dry conditions. Media exposure had minimal impact on the KHC of surgeon's and square knots, however the knots tied with media exposed 3USP polyglactin 910 are able to achieve similar KHC's to their dry variants when constructed with fewer throws. Unlike the surgeon's and square knots, Aberdeen knots tied with either media

exposed 3USP polyglactin 910 or 2USP polydioxanone showed significant increases in KHC when compared to their dry variants at all throw combinations, demonstrating that media influences self-locking knots in large gauge suture.

Multiple studies have analyzed suture material exposed to isotonic or biologic solutions with the aim of determining any detrimental effect over time that exposure might have on KHC or tensile strength.^{31,78,80,118} Other work has assessed suture material exposed to saline, plasma, fat and other media designed to recreate the surgical environment in order to evaluate the effect of these media on the material itself.^{28,29,53,74} However, to the author's knowledge, a direct comparison of KHC between dry knots and knots tied immediately after exposure to media has not been performed with large gauge suture. The media studied represent a sample of the fluid components commonly encountered during an equine celiotomy.^{28-31,53,60,69,74} Interestingly, none of the four media evaluated produced a significantly different effect on the KHC. In this study, it appears that fluid media act in a similar manner with regards to their effects on knot security.

A knot under tension is dynamic, suture slides over itself as tension is placed on the knot.^{28,65} As the tension on the knot increases the energy is absorbed by the suture material, but the dynamic state of the knot prevents any focal accumulation of stress from occurring.²⁸ Exposing the suture material to the four media studied likely caused a lubricating layer to form between the strands of suture within the knot, decreasing the coefficient of friction between the suture strands.⁶⁹ As the coefficient of friction between the strands decreases, the

knot becomes more dynamic and the points of stress accumulation shift. This means that the load the suture is exposed to is distributed over a larger amount of material as opposed to a focal point. It is these properties that are thought to explain the superior KHC shown by the Aberdeen and other self-locking knots but may also explain the increase in KHC shown by square and surgeon's knots when tied with media exposed suture material.^{27,29,47} If media exposure of suture material encourages the load to be distributed over a larger amount of suture material thereby reducing any failures caused by focal point defects or stress accumulations, this may explain the consistent reduction in interquartile ranges identified between dry and media exposed knots.²⁷

When evaluating knots for both strength and security, there is a level of resistance reached by a knot at which the addition of extra throws does not increase the knot's KHC.^{27,60} Our laboratory previously determined this level of resistance under dry conditions was reached by surgeon's and square knots at 7 throws, and that Aberdeen knots should be tied with a minimum of 4 throws and 1 turn. The results from the present study show that KHC did not significantly increase as the number of throws on surgeon's and square knots exceeded 6 and 5 throws, respectively, in media exposed suture. However, the KHC of Aberdeen knots tied with more than 3 throws and one turn did not significantly increase after exposure to media. These findings suggest that pattern-ending surgeon's, square and Aberdeen knots can be tied with fewer throws after they are exposed to media to achieve the same strength as dry knots.

Knots in this study tied with 3USP polyglactin 910 had a significantly higher KHC than those tied with 2USP polydioxanone, and is in agreement with previous work showing that 3 USP polyglactin 910 has a higher tensile strength than 2 USP polydioxanone when subjected to materials tensile testing both *in vitro* and *ex vivo* as a continuous pattern in equine linea alba samples.^{10,51} Despite the obvious disparity in size, these two materials were chosen for testing as they are the largest gauge variants of absorbable monofilament and braided multifilament suture available in the United States. They are also reported to be the most commonly used suture in closing the equine linea.^{1,30,31} Although not commercially available in the United States, larger gauge suture materials such as 6 USP polyglactin 910 and 7 USP polydioxanone have been reported to display significantly higher breaking strengths than the materials analyzed in this report, it could therefore be assumed that they may provide additional knot security.^{10,24} However, as discussed in the reports investigating these larger gauge suture materials, the increased breaking strength could be at the cost of greater tissue reaction caused by the increased amount of foreign material.²⁶ Although this can theoretically be extrapolated direct investigation as to whether this is in fact the case has not been performed.

Aberdeen knots displayed a greater KHC than both surgeon's and square knots. This finding is in agreement with multiple studies highlighting the improved mechanical properties of the Aberdeen knot in smaller gauge suture^{28,56,66} Our findings also support the results of previous studies conducted by this laboratory that showed improved knot holding capacity by Aberdeen knots over pattern ending square and surgeon's knots, and further provide evidence for investigation of these knots in the equine patient.²⁷

The Aberdeen knot is known to be smaller than the more conventional surgeon's and square knots combinations.^{28,68} As expected, when knots were tied with media exposed suture material their volume was increased when compared to their dry equivalents. The Aberdeen knot impresses as it is able to provide such an improvement in KHC, while being significantly smaller in volume compared to both the surgeon's and square knots.

Limitations

The main limitation of this study is that the materials testing performed was in a single plane of motion and involved a single load-to-failure cycle, which is a limitation for any *in vitro* study of knots using a linear testing model.^{27,28,47,54,66,74} In the linea alba of a patient recovering from abdominal surgery, the suture and knot would be subjected to tensile forces in multiple planes as well as multiple load cycles. Further work into the creation of a model that better simulates this dynamic, *in vivo* environment could be used to verify our current *in vitro* findings. Another limitation of the study is that all of the knots were tied by a single operator. Although this is an advantage as far as consistency of technique is concerned, it is a disadvantage in that any differences found must be extrapolated from the findings to be related to the knots themselves and not the single operator.

In addition, while the four media studied are regularly present in the equine abdominal surgical field, this study only tested each of the media individually. Combining these media or sampling fluid from the surgical field itself may exaggerate the findings of this study and

further reduce the amount of throws needed to construct a secure knot. Further work into the creation of a model that better simulates this dynamic, *in vivo* environment could be used to alleviate this limitation and verify our current *in vitro* findings.

Conclusions

This study concludes that media exposure has a positive effect on the KHC of both surgeon's, square and Aberdeen knots. As in smaller suture sizes, large gauge suture square and surgeon's start knots have a higher knot holding capacity (KHC) than surgeon's and square end knots, and that knots tied with polyglactin 910 had a higher KHC than knots tied using polydioxanone.

This study provides additional evidence that the Aberdeen knot has a superior KHC, while requiring less suture, than both surgeon's and square pattern ending knots conventionally used in the equine celiotomy incision.^{27,28,65} Considering the findings of this study, an Aberdeen knot tied using media exposed 3USP polyglactin 910 with 3 throws and 1 turn would be recommended to end a continuous suture pattern, as it produced the largest KHC and smallest volume of all combinations evaluated.

Based on these results, the most suitable knots for a continuous pattern closure of the equine linea alba, when both KHC and knot size are accounted for, are surgeon's knots using 3 USP polyglactin 910, with 5 throws to start the pattern and an Aberdeen knot tied with 3 throws and 1 turn to end the pattern. These findings support using a smaller start knot than

previously recommended as well as using an Aberdeen knot which is both smaller in size and weight as well as stronger than the previously recommended pattern ending surgeon's knot tied with 7 throws.¹¹⁴

This encourages further investigation, and supports the possibility of clinical use of the Aberdeen knot in large gauge suture materials for equine surgical incisions. Further *ex vivo* testing of the Aberdeen knot is recommended to verify its properties.

References

1. Freeman DE, Rötting AK, Inoue OJ: Abdominal closure and complications. *Clin Tech Equine Pract* 2002;1:174-187
2. Kummer MR: Chapter 34 - Surgical Approaches to the Abdomen A2 - Auer, Jörg A, in Stick JA (ed): *Equine Surgery* (Fourth Edition), Saint Louis, W.B. Saunders, 2012, pp 407-410.
3. Budras KD, Jahrmärker G, Wünsche A: *Anatomy of the horse*. Hannover, Schlütersche, 2009.
4. Trostle SS, Wilson DG, Stone WC, et al: A study of the biomechanical properties of the adult equine linea alba: relationship of tissue bite size and suture material to breaking strength. *Vet Surg* 1994;23:435-441
5. Chism PN, Latimer FG, Patton CS, et al: Tissue strength and wound morphology of the equine linea alba after ventral median celiotomy. *Vet Surg* 2000;29:145-151
6. Mair TS, Smith LJ, Sherlock CE: Evidence-based gastrointestinal surgery in horses. *Vet Clin North Am Equine Pract* 2007;23:267-292
7. Hillyer MH, Taylor FG, French NP: A cross-sectional study of colic in horses on thoroughbred training premises in the British Isles in 1997. *Equine Vet J* 2001;33:380-385
8. Bischofberger AS, Brauer T, Gugelchuk G, et al: Difference in incisional complications following exploratory celiotomies using antibacterial-coated suture material for subcutaneous closure: Prospective randomised study in 100 horses. *Equine Vet J* 2010;42:304-309
9. Dukti S, White N: Surgical complications of colic surgery. *Vet Clin North Am Equine Pract* 2008;24:515-534, vii-viii
10. Fierheller EE, Wilson DG: An in vitro biomechanical comparison of the breaking strength and stiffness of polydioxanone (sizes 2, 7) and polyglactin 910 (sizes 3, 6) in the equine linea alba. *Vet Surg* 2005;34:18-23
11. Phillips TJ, Walmsley JP: Retrospective analysis of the results of 151 exploratory laparotomies in horses with gastrointestinal disease. *Equine Vet J* 1993;25:427-431
12. Kobluk CN, Ducharme NG, Lumsden JH, et al: Factors affecting incisional complication rates associated with colic surgery in horses: 78 cases (1983-1985). *J Am Vet Med Assoc* 1989;195:639-642
13. Mair TS, Smith LJ: Survival and complication rates in 300 horses undergoing surgical treatment of colic. Part 1: Short-term survival following a single laparotomy. *Equine Vet J* 2005;37:296-302

14. Proudman CJ, Smith JE, Edwards GB, et al: Long-term survival of equine surgical colic cases. Part 1: patterns of mortality and morbidity. *Equine Vet J* 2002;34:432-437
15. Freeman DE, Hammock P, Baker GJ, et al: Short- and long-term survival and prevalence of postoperative ileus after small intestinal surgery in the horse. *Equine Vet J Suppl* 2000;32:42-51
16. Gibson KT, Curtis CR, Turner AS, et al: Incisional hernias in the horse. Incidence and predisposing factors. *Vet Surg* 1989;18:360-366
17. French NP, Smith J, Edwards GB, et al: Equine surgical colic: risk factors for postoperative complications. *Equine Vet J* 2002;34:444-449
18. Mair TS, Smith LJ: Survival and complication rates in 300 horses undergoing surgical treatment of colic. Part 3: Long-term complications and survival. *Equine Vet J* 2005;37:310-314
19. Honnas CM, Cohen ND: Risk factors for wound infection following celiotomy in horses. *J Am Vet Med Assoc* 1997;210:78-81
20. Coomer R, Mair T, Edwards G, et al: Do subcutaneous sutures increase risk of laparotomy wound suppuration? *Equine veterinary journal* 2007;39:396-399
21. Wilson DA, Baker GJ, Boero MJ: Complications of celiotomy incisions in horses. *Vet Surg* 1995;24:506-514
22. Galuppo LD, Pascoe JR, Jang SS, et al: Evaluation of iodophor skin preparation techniques and factors influencing drainage from ventral midline incisions in horses. *J Am Vet Med Assoc* 1999;215:963-969
23. Edlich RF, Panek PH, Rodeheaver GT, et al: Physical and chemical configuration of sutures in the development of surgical infection. *Ann Surg* 1973;177:679-688
24. Anderson SL, Bracamonte JL, Hendrick S, et al: Ex vivo comparison of 7 polydioxanone, 2 polyglactin 910 for closure of ventral median celiotomy in horses. *Vet Surg* 2013;42:463-467
25. Anderson SL, Bracamonte JL, Hendrick S, et al: Ex vivo comparison of bursting strength of ventral median and right ventral paramedian celiotomies in horses. *Vet Surg* 2013;42:468-472
26. Anderson SL, Bracamonte JL, Hendrick S: Ex vivo evaluation of 7 polydioxanone for closure of equine ventral midline celiotomies. *Can J Vet Res* 2014;78:156-160
27. Gillen AM, Munsterman AS, Farag R, et al: In Vitro Evaluation of the Aberdeen Knot for Continuous Suture Patterns with Large Gauge Suture. *Vet Surg* 2016;45:955-961

28. Schaaf O, Glyde M, Day RE: In vitro comparison of secure Aberdeen and square knots with plasma- and fat-coated polydioxanone. *Vet Surg* 2010;39:553-560
29. Schaaf O, Glyde M, Day RE: A secure Aberdeen knot: in vitro assessment of knot security in plasma and fat. *J Small Anim Pract* 2009;50:415-421
30. Kümmerle JM: Chapter 16 - Suture Materials and Patterns, in Auer JA, Stick JA (eds): *Equine Surgery* (ed 4), Saint Louis, W.B. Saunders, 2012, pp 181-202.
31. Sanders RE, Kearney CM, Buckley CT, et al: Knot Security of 5 Metric (USP 2) Sutures: Influence of Knotting Technique, Suture Material, and Incubation Time for 14 and 28 Days in Phosphate Buffered Saline and Inflamed Equine Peritoneal Fluid. *Vet Surg* 2015;44:723-730
32. Trostle S, Hendrickson D: Suture sinus formation following closure of ventral midline incisions with polypropylene in three horses. *Journal of the American Veterinary Medical Association* 1995;207:742-745
33. Van Rijssel EJ, Brand R, Admiraal C, et al: Tissue reaction and surgical knots: the effect of suture size, knot configuration, and knot volume. *Obstet Gynecol* 1989;74:64-68
34. Tulleners EP, Donawick WJ: Secondary closure of infected abdominal incisions in cattle and horses. *J Am Vet Med Assoc* 1983;182:1377-1379
35. Schumacher J, Hanselka D, Adams G, et al: Stainless steel closure of the equine linea alba. *Equine Practice* 1981;3:
36. Ducharme NG, Hackett RP, Ducharme GR, et al: Surgical-Treatment of Colic - Results in 181 Horses. *Veterinary Surgery* 1983;12:206-209
37. Marturello DM, McFadden MS, Bennett RA, et al: Knot security and tensile strength of suture materials. *Vet Surg* 2014;43:73-79
38. Trimpos JB, Klopper PJ: Knot security of synthetic absorbable suture material; a comparison of polyglycolic acid and polyglactin-910. *Eur J Obstet Gynecol Reprod Biol* 1985;19:183-190
39. Jones RD, Jampani HB, Newman JL, et al: Triclosan: a review of effectiveness and safety in health care settings. *Am J Infect Control* 2000;28:184-196
40. Rothenburger S, Spangler D, Bhende S, et al: In vitro antimicrobial evaluation of Coated VICRYL* Plus Antibacterial Suture (coated polyglactin 910 with triclosan) using zone of inhibition assays. *Surg Infect (Larchmt)* 2002;3:s79-s87
41. Marco F, Vallez R, Gonzalez P, et al: Study of the efficacy of coated Vicryl Plus® antibacterial suture in an animal model of orthopedic surgery. *Surgical infections* 2007;8:359-366

42. Storch ML, Rothenburger SJ, Jacinto G: Experimental efficacy study of coated VICRYL plus antibacterial suture in guinea pigs challenged with *Staphylococcus aureus*. *Surg Infect (Larchmt)* 2004;5:281-288
43. Ford HR, Jones P, Gaines B, et al: Intraoperative handling and wound healing: controlled clinical trial comparing coated VICRYL® Plus antibacterial suture (coated polyglactin 910 suture with triclosan) with Coated VICRYL® suture (coated polyglactin 910 suture). *Surg Infect (Larchmt)* 2005;6:313-321
44. Fleck T, Moidl R, Blacky A, et al: Triclosan-coated sutures for the reduction of sternal wound infections: economic considerations. *Ann Thorac Surg* 2007;84:232-236
45. Klohn A: New perspectives in postoperative complications after abdominal surgery. *Vet Clin North Am Equine Pract* 2009;25:341-350
46. White NA, Moore JN, Mair TS: Equine acute abdomen, CRC Press, 2009.
47. Mulon PY, Zhim F, Yahia L, et al: The effect of six knotting methods on the biomechanical properties of three large diameter absorbable suture materials. *Vet Surg* 2010;39:561-565
48. Campbell EJ, Bailey JV: Mechanical properties of suture materials in vitro and after in vivo implantation in horses. *Vet Surg* 1992;21:355-361
49. Price PB: Stress, strain and sutures. *Annals of surgery* 1948;128:408
50. Tera H, Aberg C: Tensile strengths of twelve types of knot employed in surgery, using different suture materials. *Acta Chirurgica Scandinavica* 1975;142:1-7
51. Von Fraunhofer JA, Storey RJ, Masterson BJ: Tensile properties of suture materials. *Biomaterials* 1988;9:324-327
52. Von Fraunhofer JA, Storey RS, Stone IK, et al: Tensile strength of suture materials. *J Biomed Mater Res* 1985;19:595-600
53. Fugazzi RW, Fransson BA, Curran KM, et al: A biomechanical study of laparoscopic 4S-modified Roeder and Weston knot strength in 3-0 polyglactin 910 and 3-0 polydioxanone. *Vet Surg* 2013;42:198-204
54. Rosin E, Robinson GM: Knot security of suture materials. *Vet Surg* 1989;18:269-273
55. Rodeheaver GT, Green CW, Odum BC, et al: Technical considerations in knot construction, part III. Knot asymmetry. *J Emerg Med* 1998;16:635-639
56. Shaw AD, Duthie GS: A simple assessment of surgical sutures and knots. *J R Coll Surg Edinb* 1995;40:388-391

57. Ching SS, Mok CW, Koh YX, et al: Assessment of surgical trainees' quality of knot-tying. *J Surg Educ* 2013;70:48-54
58. Annunziata CC, Drake DB, Woods JA, et al: Technical considerations in knot construction. Part I. Continuous percutaneous and dermal suture closure. *J Emerg Med* 1997;15:351-356
59. Richey ML, Roe SC: Assessment of knot security in continuous intradermal wound closures. *J Surg Res* 2005;123:284-288
60. Muffly TM, Kow N, Iqbal I, et al: Minimum number of throws needed for knot security. *J Surg Educ* 2011;68:130-133
61. Daes J: Self-locking first stitch in suture reinforcement of the laparoscopic gastric sleeve. *Obes Surg* 2013;23:794-795
62. Serra C, Perez N, Bou R, et al: Sliding self-locking first stitch and Aberdeen knot in suture reinforcement with omentoplasty of the laparoscopic gastric sleeve staple line. *Obes Surg* 2014;24:1739-1740
63. Wattchow D, Watts JM: The half blood knot for tying nylon in surgery. *British journal of surgery* 1984;71:333-333
64. Delimar D, Koržinek K: A secure knot for suturing structures under tension. *The European journal of surgery* 1996;162:505-506
65. Stott PM, Ripley LG, Lavelle MA: The ultimate Aberdeen knot. *Ann R Coll Surg Engl* 2007;89:713-717
66. Fong ED, Bartlett AS, Malak S, et al: Tensile strength of surgical knots in abdominal wound closure. *ANZ J Surg* 2008;78:164-166
67. Gillen AM, Munsterman AS, Hanson RR: In Vitro Evaluation of the Size, Knot Holding Capacity, and Knot Security of the Forwarder Knot Compared to Square and Surgeon's Knots Using Large Gauge Suture. *Veterinary Surgery* 2016:
68. Regier PJ, Smeak DD, Coleman K, et al: Comparison of volume, security, and biomechanical strength of square and Aberdeen termination knots tied with 4-0 polyglyconate and used for termination of intradermal closures in canine cadavers. *J Am Vet Med Assoc* 2015;247:260-266
69. Gupta BS, Wolf KW, Postlethwait RW: Effect of lubrication of frictional properties of sutures. *Surg Gynecol Obstet* 1985;161:416-418
70. Gupta B, Wolf K, Postlethwait R: Effect of suture material and construction on frictional properties of sutures. *Surgery, gynecology & obstetrics* 1985;161:12-16

71. Dinsmore RC: Understanding surgical knot security: a proposal to standardize the literature. *J Am Coll Surg* 1995;180:689-699
72. Herrmann JB: Tensile strength and knot security of surgical suture materials. *Am Surg* 1971;37:209-217
73. van Rijssel EJ, Trimbos JB, Booster MH: Mechanical performance of square knots and sliding knots in surgery: comparative study. *Am J Obstet Gynecol* 1990;162:93-97
74. Muffly TM, Couri B, Edwards A, et al: Effect of petroleum gauze packing on the mechanical properties of suture materials. *J Surg Educ* 2012;69:37-40
75. Tera H, Aberg C: The strength of suture knots after one week in vivo. *Acta Chirurgica Scandinavica* 1975;142:301-307
76. Chu C, Moncrief G: An in vitro evaluation of the stability of mechanical properties of surgical suture materials in various pH conditions. *Annals of surgery* 1983;198:223
77. Schiller T, Stone E, Gupta B: In vitro loss of tensile strength and elasticity of five absorbable suture materials in sterile and infected canine urine. *Veterinary Surgery* 1993;22:208-212
78. Muftuoglu MA, Ozkan E, Saglam A: Effect of human pancreatic juice and bile on the tensile strength of suture materials. *Am J Surg* 2004;188:200-203
79. Nichols S, Anderson DE: Breaking strength and elasticity of synthetic absorbable suture materials incubated in phosphate-buffered saline solution, milk, and milk contaminated with *Streptococcus agalactiae*. *Am J Vet Res* 2007;68:441-445
80. Kearney CM, Buckley CT, Jenner F, et al: Elasticity and breaking strength of synthetic suture materials incubated in various equine physiological and pathological solutions. *Equine Vet J* 2014;46:494-498
81. Rodeheaver GT, Thacker JG, Owen J, et al: Knotting and handling characteristics of coated synthetic absorbable sutures. *J Surg Res* 1983;35:525-530
82. Gupta B, Postlethwait R: An analysis of surgical knot security in sutures, Proc, Ist World Biomaterials Congress, Baden near Vienna, Austria, April, 1980, p[^]pp 8-12
83. Taylor FW: Surgical Knots. *Ann Surg* 1938;107:458-468
84. Holmlund DEW: Knot properties of surgical suture materials. *European Surgical Research* 1974;6:65-71
85. Tera H, Aberg C: Strength of knots in surgery in relation to type of knot, type of suture material and dimension of suture thread. *Acta Chirurgica Scandinavica* 1976;143:75-83

86. Chu CC: Mechanical properties of suture materials: an important characterization. *Ann Surg* 1981;193:365-371
87. Schubert DC, Unger JB, Mukherjee D, et al: Mechanical performance of knots using braided and monofilament absorbable sutures. *American journal of obstetrics and gynecology* 2002;187:1438-1442
88. Haxton HA: A comparison of the action of extension of the knee and elbow joints in man. *Anat Rec* 1945;93:279-286
89. Haxton HA: Absolute muscle force in the ankle flexors of man. *J Physiol* 1944;103:267-273
90. Haxton HA: Intra-abdominal and intrauterine pressures. *Br Med J* 1948;1:856
91. Drye JC: Intraperitoneal pressure in the human. *Surg Gynecol Obstet* 1948;87:472-475
92. Haxton HA: The Influence of Suture Materials and Methods on the Healing of Abdominal Wounds. *Br J Surg* 1965;52:372-375
93. Poole Jr G, Meredith J, Kon N, et al: Suture technique and wound-bursting strength. *The American surgeon* 1984;50:569-572
94. Rodeheaver GT, Nesbit WS, Edlich RF: Novafil. A dynamic suture for wound closure. *Ann Surg* 1986;204:193-199
95. Seid MH, McDaniel-Owens LM, Poole GV, Jr., et al: A randomized trial of abdominal incision suture technique and wound strength in rats. *Arch Surg* 1995;130:394-397
96. Kon ND, Meredith JW, Poole GV, Jr., et al: Abdominal wound closure. A comparison of polydioxanone, polypropylene, and Teflon-coated braided Dacron sutures. *Am Surg* 1984;50:549-551
97. Sanders RJ, DiClementi D, Ireland K: Principles of abdominal wound closure. I. Animal studies. *Arch Surg* 1977;112:1184-1187
98. Magee AA, Galuppo LD: Comparison of incisional bursting strength of simple continuous and inverted cruciate suture patterns in the equine linea alba. *Vet Surg* 1999;28:442-447
99. Hassan KA, Galuppo LD, van Hoogmoed LM: An in vitro comparison of two suture intervals using braided absorbable loop suture in the equine linea alba. *Vet Surg* 2006;35:310-314
100. Anderson SL, Vacek JR, MacHarg MA, et al: Occurrence of Incisional Complications and Associated Risk Factors Using a Right Ventral Paramedian Celiotomy Incision in 159 Horses. *Veterinary Surgery* 2011;40:82-89

101. Auer JA: Chapter 76 - Principles of Fracture Treatment, in Equine Surgery (Fourth Edition), Saint Louis, W.B. Saunders, 2012, pp 1047-1081.
102. Disegi JA: Chapter 75 - Metallic Instruments and Implants A2 - Auer, Jörg A, in Stick JA (ed): Equine Surgery (Fourth Edition), Saint Louis, W.B. Saunders, 2012, pp 1040-1047.
103. Zantop T, Eggers AK, Musahl V, et al: Cyclic testing of flexible all-inside meniscus suture anchors biomechanical analysis. *The American journal of sports medicine* 2005;33:388-394
104. Seil R, Rupp S, Kohn DM: Cyclic testing of meniscal sutures. *Arthroscopy* 2000;16:505-510
105. Choate CJ, Lewis DD, Conrad BP, et al: Assessment of the craniocaudal stability of four extracapsular stabilization techniques during two cyclic loading protocols: a cadaver study. *Vet Surg* 2013;42:853-859
106. Rose ND, Goerke D, Evans RB, et al: Mechanical testing of orthopedic suture material used for extra-articular stabilization of canine cruciate ligament-deficient stifles. *Veterinary Surgery* 2012;41:266-272
107. Vianna ML, Roe SC: Mechanical Comparison of Two Knots and Two Crimp Systems for Securing Nylon Line Used for Extra-Articular Stabilization of the Canine Stifle. *Veterinary Surgery* 2006;35:567-572
108. Santos MP, Gutierrez-Nibeyro SD, Horn GP, et al: In vitro mechanical evaluation of equine laryngeal tie-forward constructs prepared with different suture materials and placement patterns. *Am J Vet Res* 2015;76:373-383
109. Santos MP, Gutierrez-Nibeyro SD, Horn GP, et al: Mechanical properties of various suture materials and placement patterns tested with surrogate in vitro model constructs simulating laryngeal advancement tie-forward procedures in horses. *American Journal of Veterinary Research* 2014;75:500-506
110. Willsallen H, Heller J, Kark L, et al: In vitro mechanical testing of braided polyurethane elastic fiber and braided polyester for equine laryngoplasty. *Vet Surg* 2015;44:223-230
111. Gillen AM, Munsterman AS, Farag R, et al: In vitro evaluation of square and surgeon's knots in large gauge suture. *Vet Surg* 2017;46:297-305
112. Williams D: Biodegradation of surgical polymers. *J Mater Sci* 1982;17:1233-1246
113. Herrmann JB: Changes in tensile strength and knot security of surgical sutures in vivo. *Arch Surg* 1973;106:707-710

114. Gillen A, Munsterman AS, Farag R, et al: Evaluation of the Aberdeen Knot for Continuous Suture Patterns with Large Gauge Suture, Proc, American College of Veterinary Surgeons Surgery Summit, San Diego, CA, October, 2014, pp E151-E211
115. Brown RP: Knotting technique and suture materials. *Br J Surg* 1992;79:399-400
116. Israelsson L, Jonsson T: Physical properties of self locking and conventional surgical knots. *Eur J Surg* 1993;160:323-327
117. Freeman DE: Abdominal Closure, in White NA, Moore JN, Mair TS (eds): *Equine Acute Abdomen*, Jackson, WY, Teton NewMedia, 2009, pp 539-550.
118. Greenberg CB, Davidson EB, Bellmer DD, et al: Evaluation of the tensile strengths of four monofilament absorbable suture materials after immersion in canine urine with or without bacteria. *American journal of veterinary research* 2004;65:847-853

Appendix

Methods of knot construction

Figure 1.1: Square knot

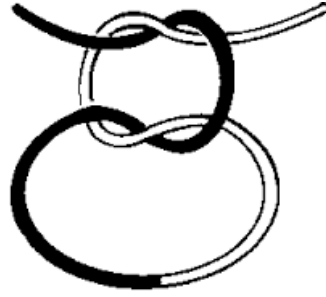

Figure 1.2: Surgeon's knot

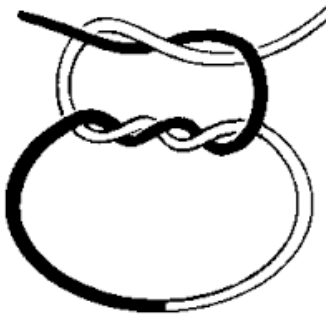

Figure 1.3: Aberdeen knot

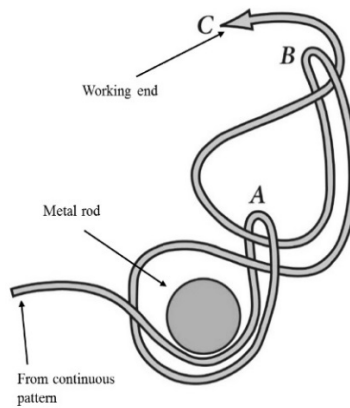

Figure 1.4: The Half-Blood knot from Richey, et al.⁵⁹

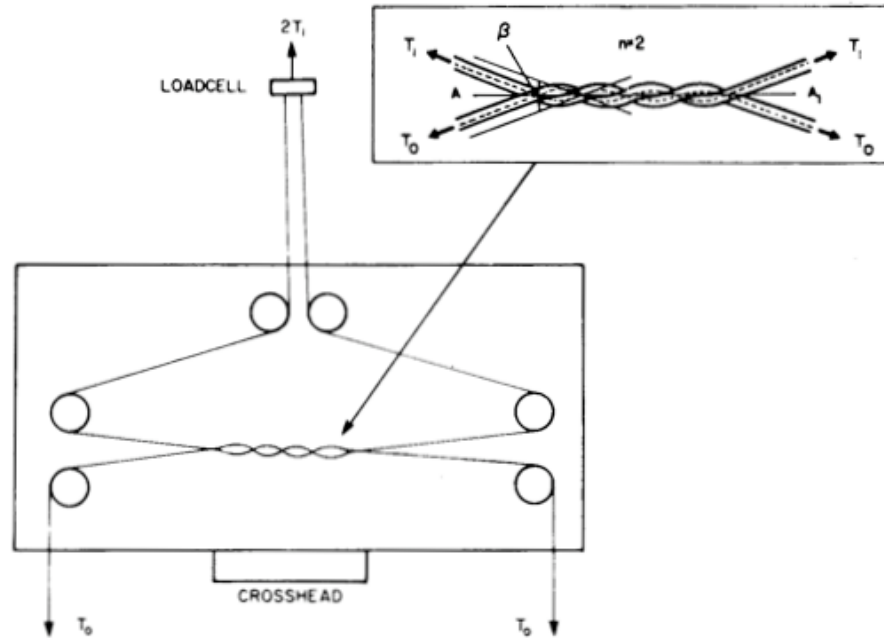

Figure 1.5: The Forwarder knot from Gillen, et al.



Methods of suture/ knot evaluation

Figure 2.1 from: Gupta, et al.⁷⁰



Depiction of the apparatus which allowed a modified twist test to be used with an Instron materials testing machine.

Figure 2.2 from: Tera, H. et al. TeraAberg⁵⁰

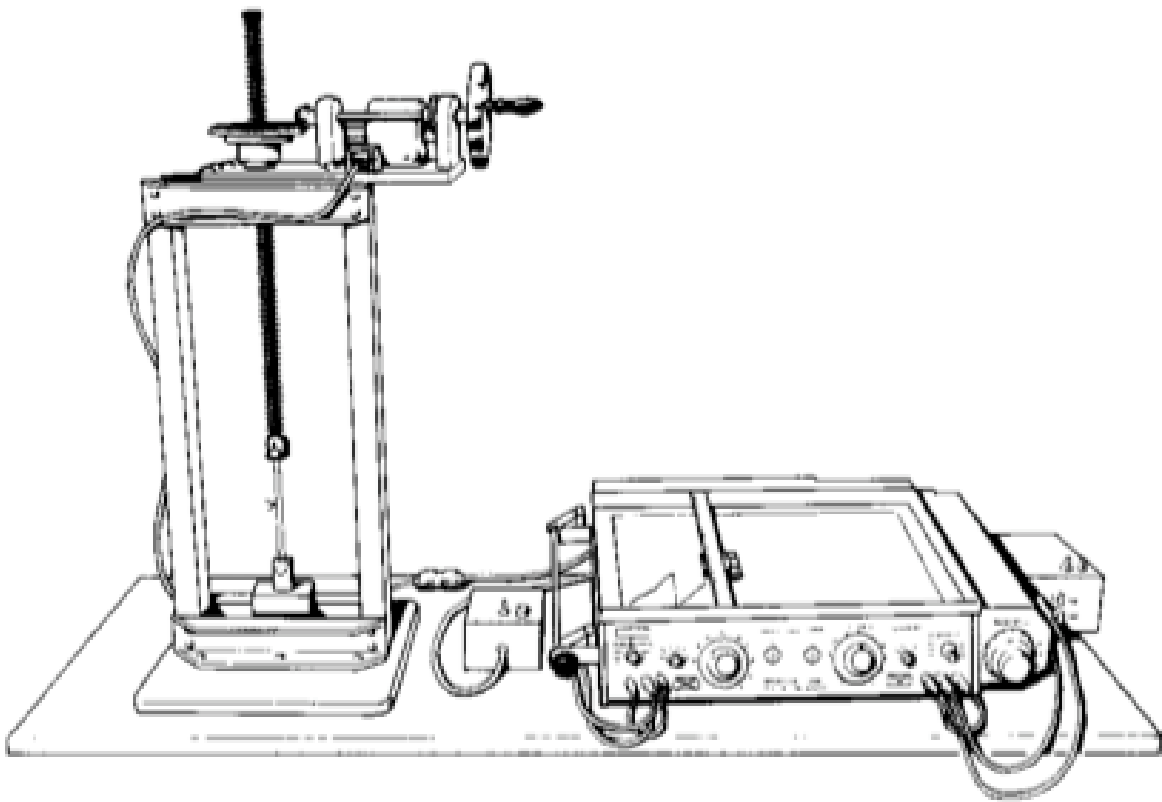

A depiction of the apparatus used to perform knot tensile testing. This apparatus is a demonstration of the “loop” method of suture testing.

Figure 2.3 from: Chu, C.C.⁸⁶

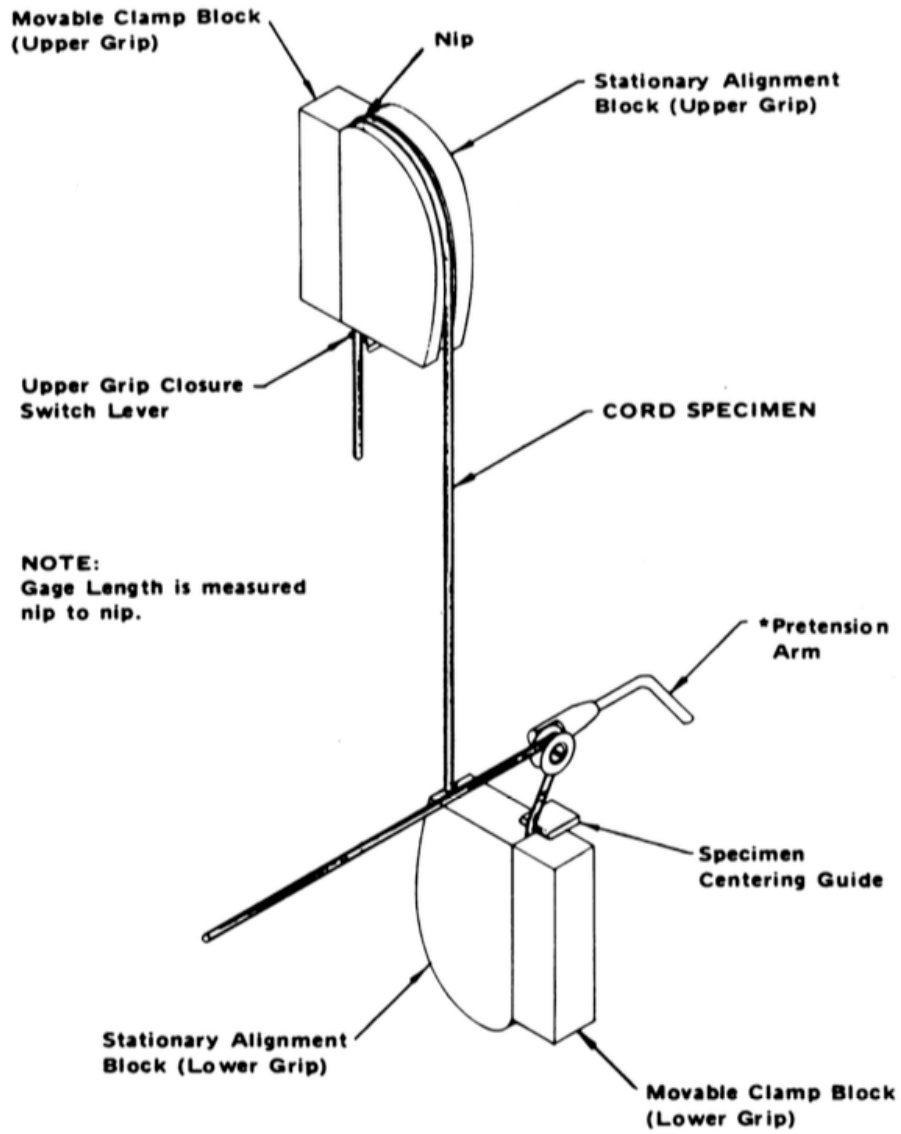

A schematic drawing of a specimen loaded between two yarn grips on an Instron materials testing machine. This is a representation of the “single strand” testing method.

Figure 2.4 from: Von Fraunhofer et al.⁵²

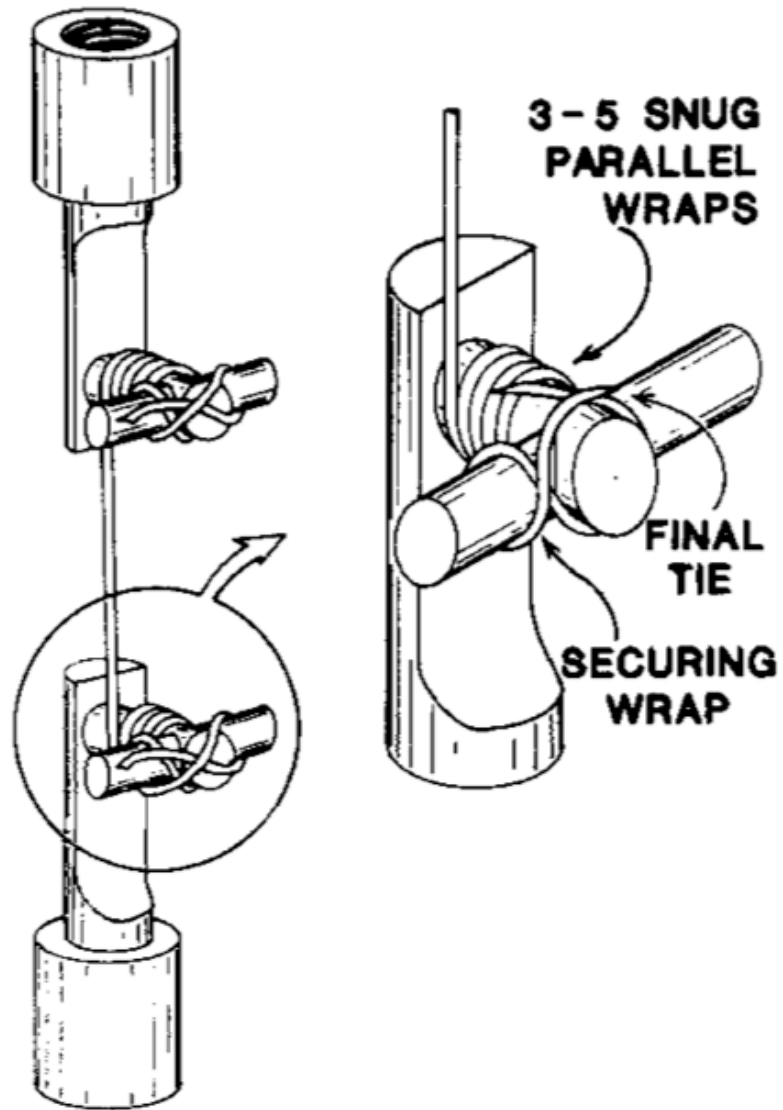

A drawing depicting how a suture strand was secured onto the cleat jig. Once secured the jigs were distracted using a Unite-O-Matic FM-20 universal testing machine.

Figure 2.5 from: Schaaf et al.²⁸



A photographic depiction of a knot tied around a polished metal rod with the free end glued between two rubber pads held in the upper grip of an Instron materials testing machine. The picture also shows the custom plastic casing used to catch the knot after failure.

Figure 2.6 from: Fierheller et al.¹⁰

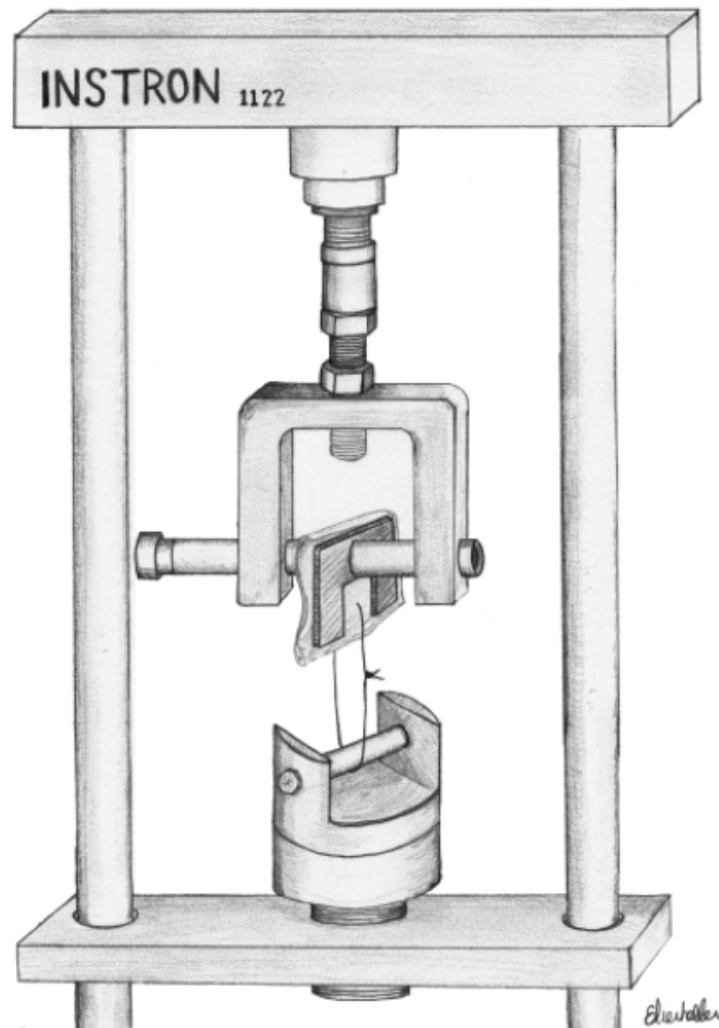

A drawing depicting the experimental method used to perform mechanical testing. The suture loop is passed through the tissue which is held in the upper grip of the Instron testing machine using “U” grips. The lower grip holds a metal rod which the suture loop also passes around.

Figure 2.7 from: Schiller, T.D, et al.⁷⁷

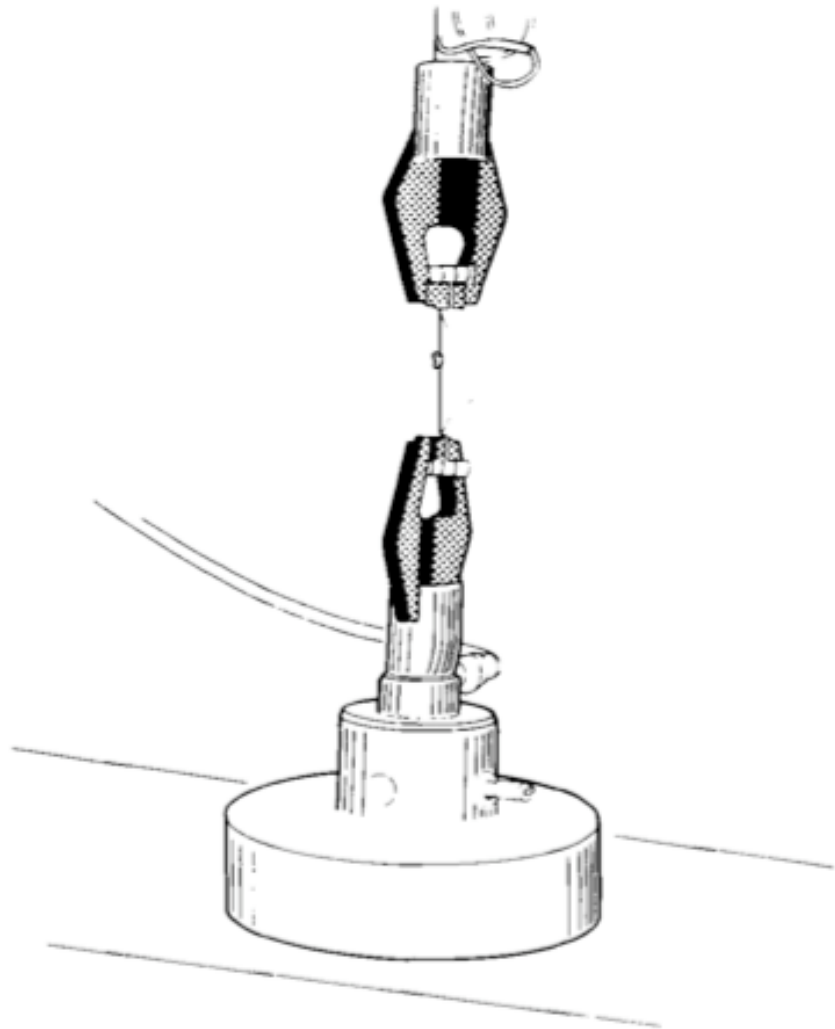

An image depicting the experimental set up used in this study. The metal rods which the suture was wrapped around are seen above the jaws of the top clamp and below the jaws of the bottom clamp. A knot was placed in the middle of the strand to provide a uniform breaking site.

Figure 2.8 from: Sanders, R.E. et al.³¹



A photographic image depicting the custom built 20mm diameter split circular jaw mounted in the materials testing machine.

Figure 2.9 from: Magee, A.A. et al.⁹⁸

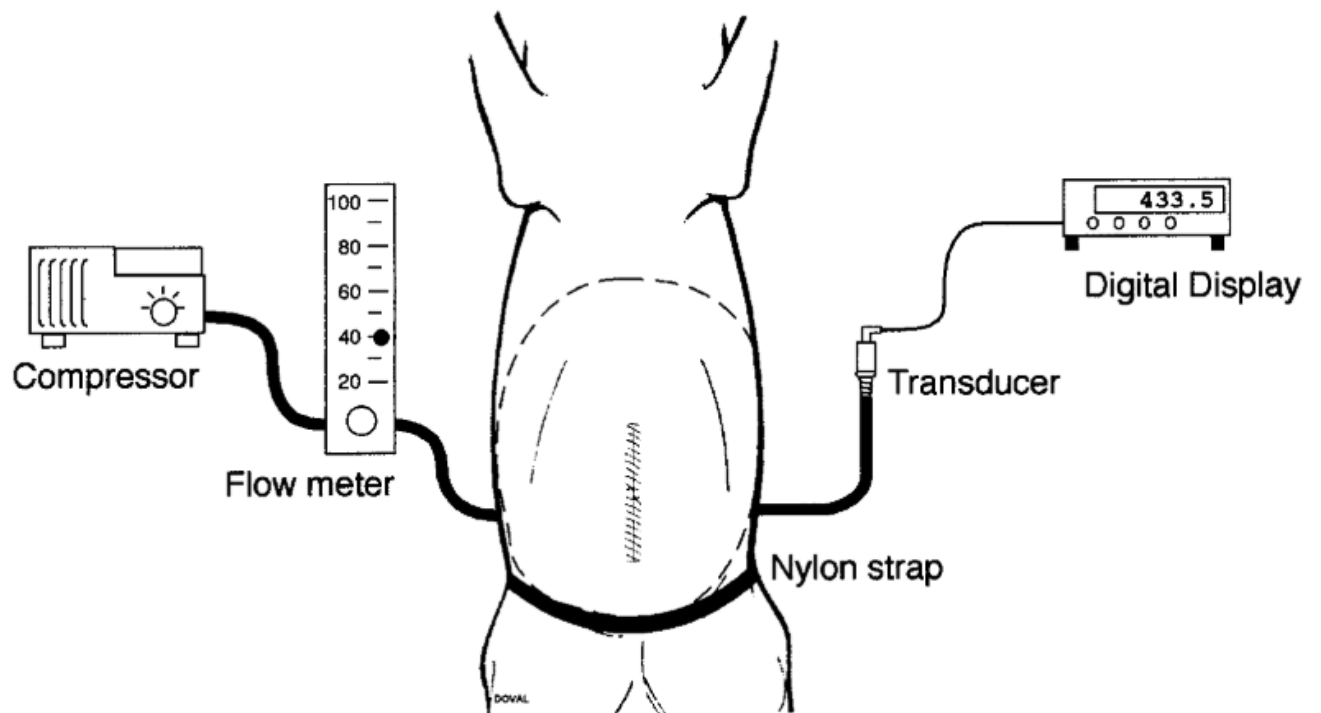

A diagram of the experimental apparatus used for measuring bursting pressure of the linea alba. The dotted line represents the polyurethane bladder within the abdomen. Air was pumped into the bladder through a flow meter regulated air compressor. A transducer then measured abdominal pressure which was displayed digitally. A nylon strap was used to prevent herniation of the abdominal contents into the retroperitoneal and inguinal regions.

Figures from Materials and Methods

Figure 3.1

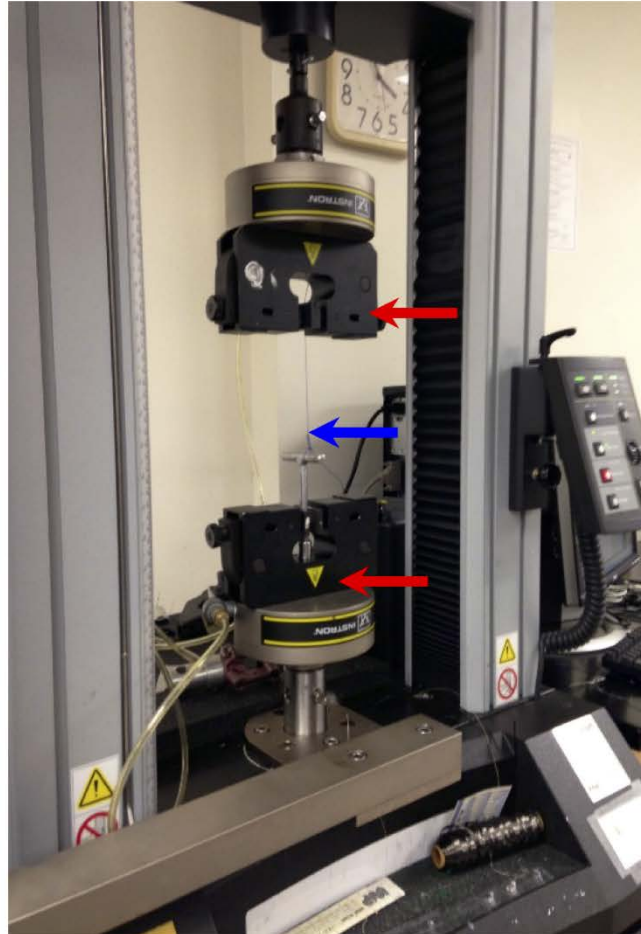

The INSTRON Universal testing machine used in this study to test knots exposed to biologic media. The red arrows indicate the upper and lower testing grips. The blue arrow indicates the suture on the testing apparatus.

Figure 3.2

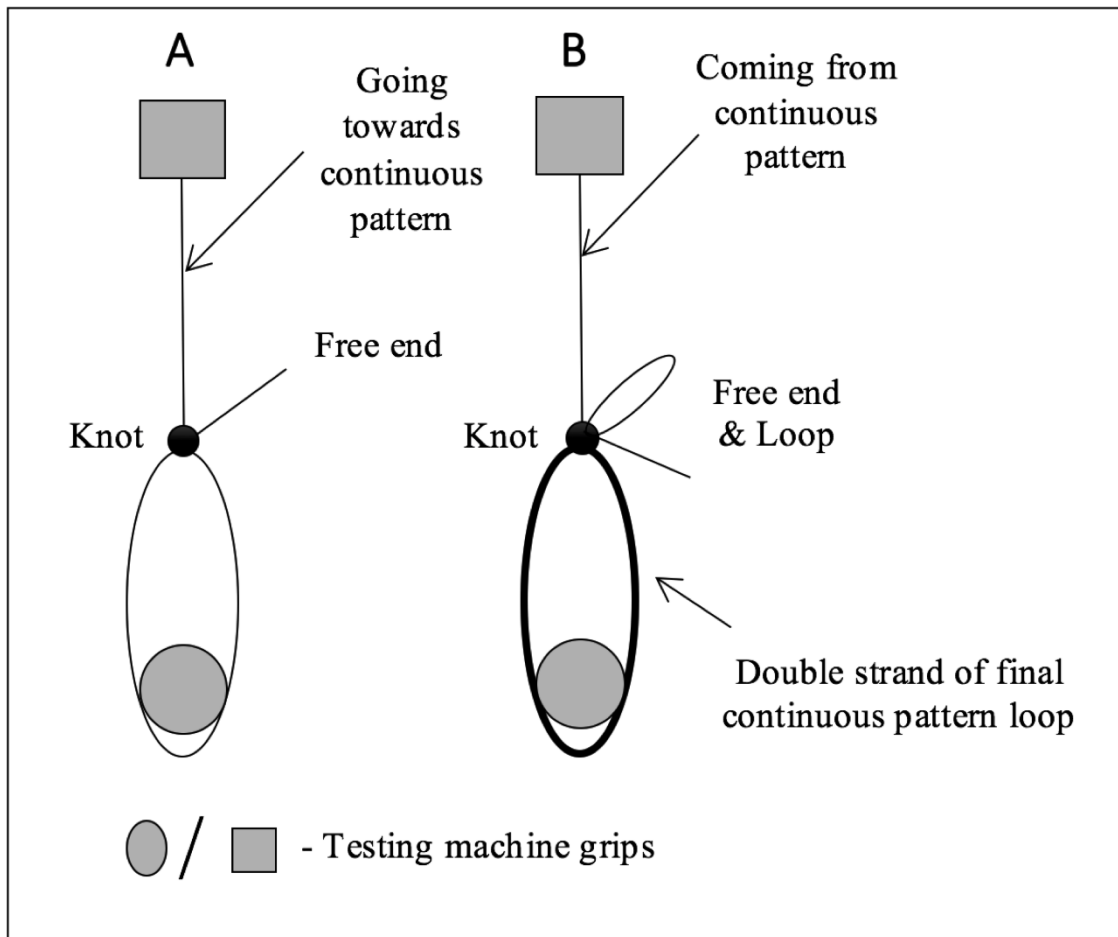

Testing protocol for surgeon's and square knots where schematic A shows how start surgeon's and square knots were placed on the testing apparatus, and schematic B shows how end surgeon's and square knots were tested.

Figure 3.3

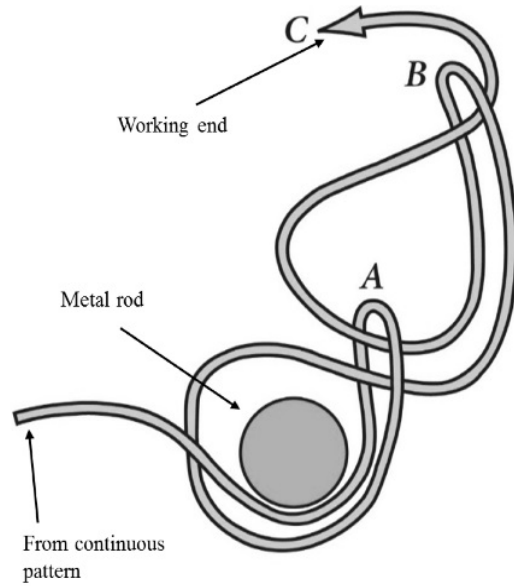
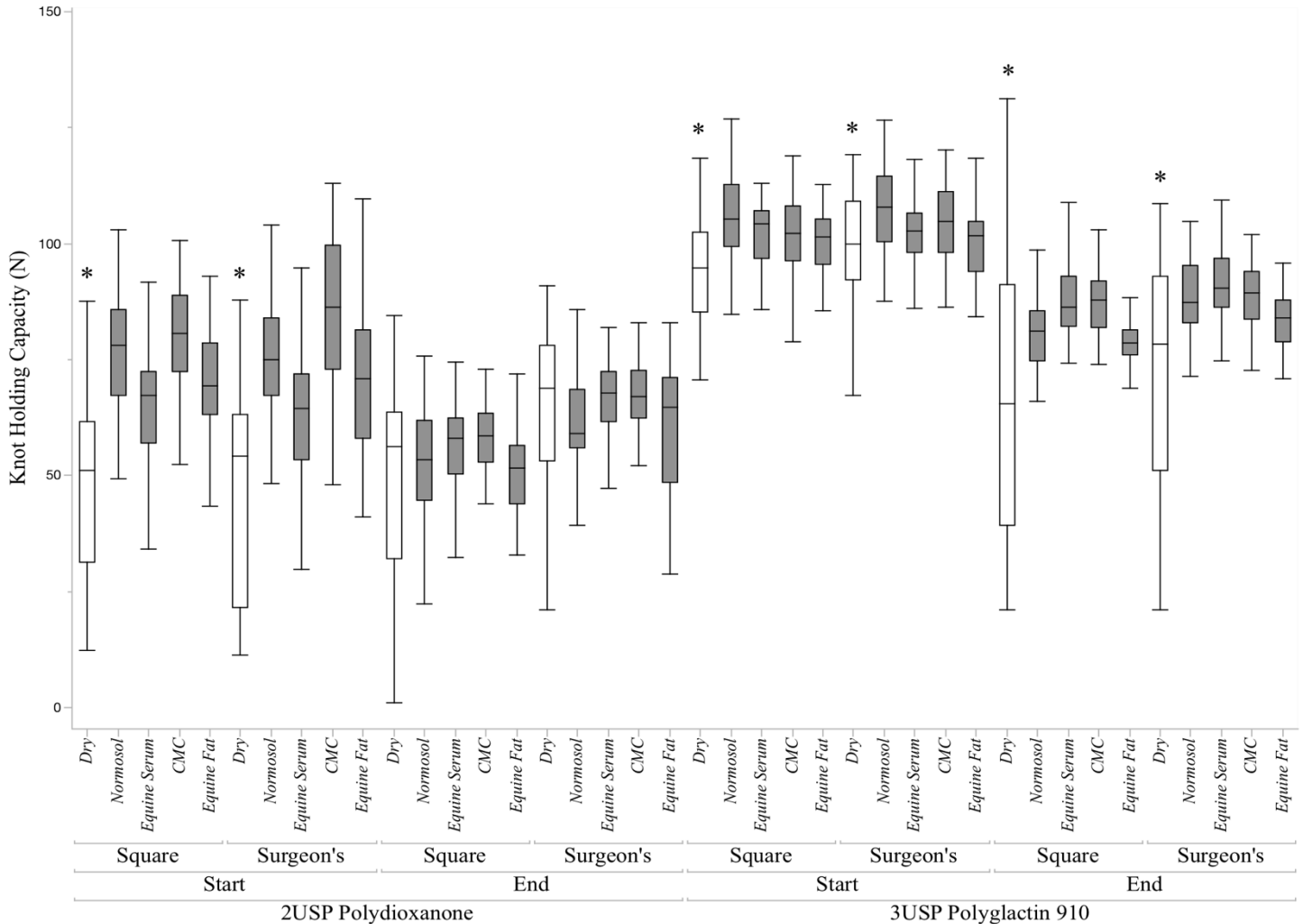

Diagram depicting the method used to tie an Aberdeen knot. A loop is formed in the working end of the suture (A). A loop made from the working end of the suture is then passed through this loop (B). This is considered a throw, and can be repeated at the surgeon's discretion. The knot is finished and secured by passing the working end of the suture through the last the loop (C), this is called the "turn."

Graphs

Figure 4.1



Box plot (median, 25% and 75% quartiles and range) showing the effect of media exposure on start and end, surgeon's and square knots. Overall, knots tied with 3 USP polyglactin 910 had a higher KHC than knots tied with 2 USP polydioxanone ($P < 0.0001$). When knots were tied with 3 USP polyglactin 910, the start knots had a significantly higher KHC than end knots ($P < 0.0001$). All knots, apart from end knots tied with 2 USP polydioxanone ($P = 0.1$), tied with media exposed suture showed an improved KHC when compared with knots tied in dry conditions ($P < 0.0008$). Box plots marked with an astrix were identified to have a significantly lower KHC ($P < 0.05$) when compared to other knots within their category (*)

Figure 4.2



Bar chart showing the effect of media exposure on weight of surgeon's and square, start and end knots tied with 2USP Polydioxanone and 3USP Polyglactin 910. Overall, end knots were significantly heavier than start knots ($P < 0.0001$) and surgeon's knots were significantly heavier than square knots ($P < 0.006$). Knot weight varied with media exposure although knots tied with suture exposed to equine abdominal fat tended to be heavier than knots tied in dry conditions.

Figure 4.3

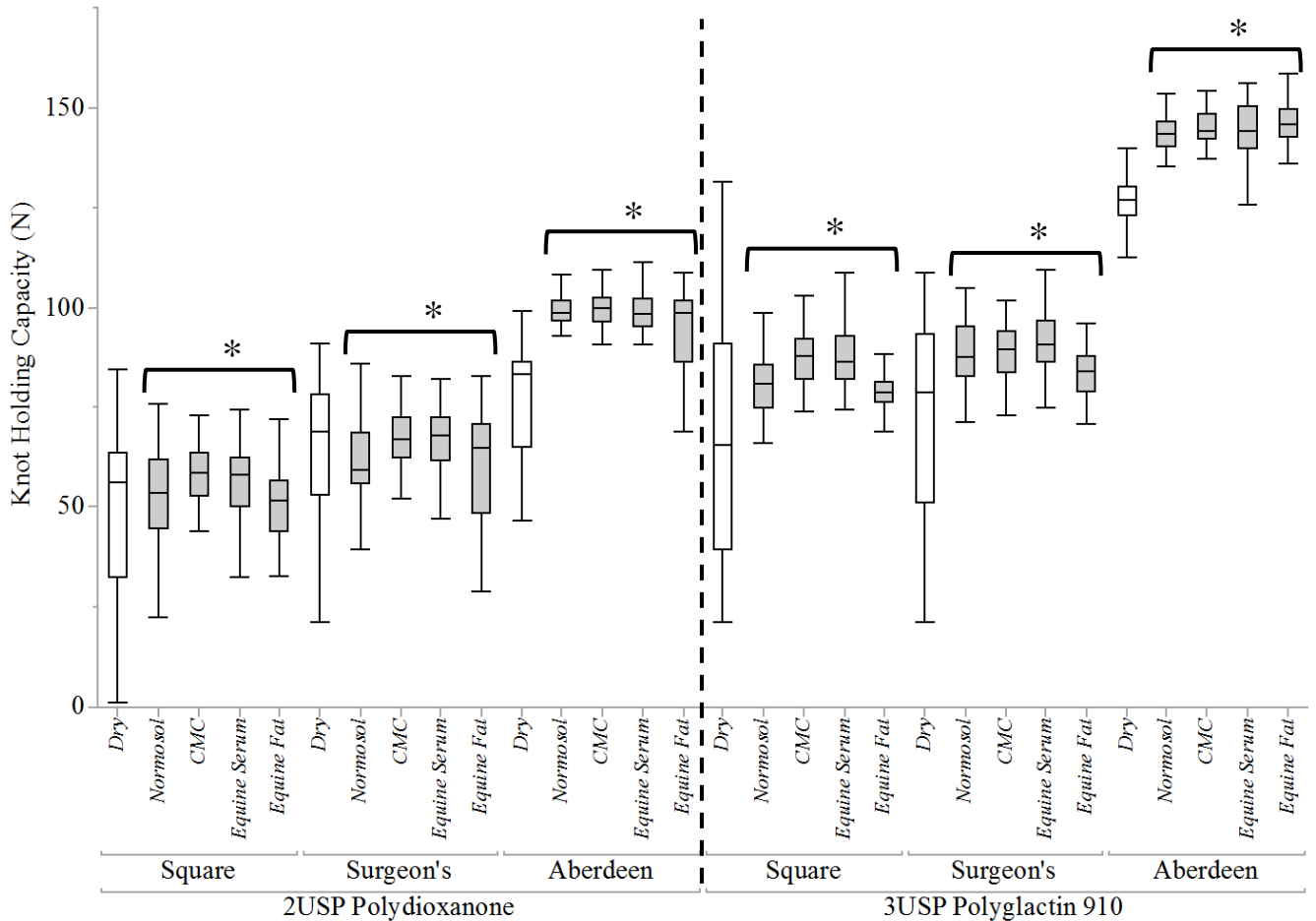

A box plot (median, 25% and 75% quartiles and range) showing the effect of media exposure on the knot holding capacity (KHC) of surgeon's, square and Aberdeen knots tied with either 2 USP polydioxanone or 3 USP polyglactin 910. The white box plots represent knots tied with dry suture. The grey box plots represent the knots tied with suture exposed to either Normosol, 1% CMC, equine serum and equine abdominal fat. No significant differences in KHC were identified among the knots tied with suture exposed to any of the 4 media ($P < 0.0001$). No significant difference in KHC was identified between the data groups represented by the grey box plots within each bracket and labelled with an asterisk (*)

Figure 4.4

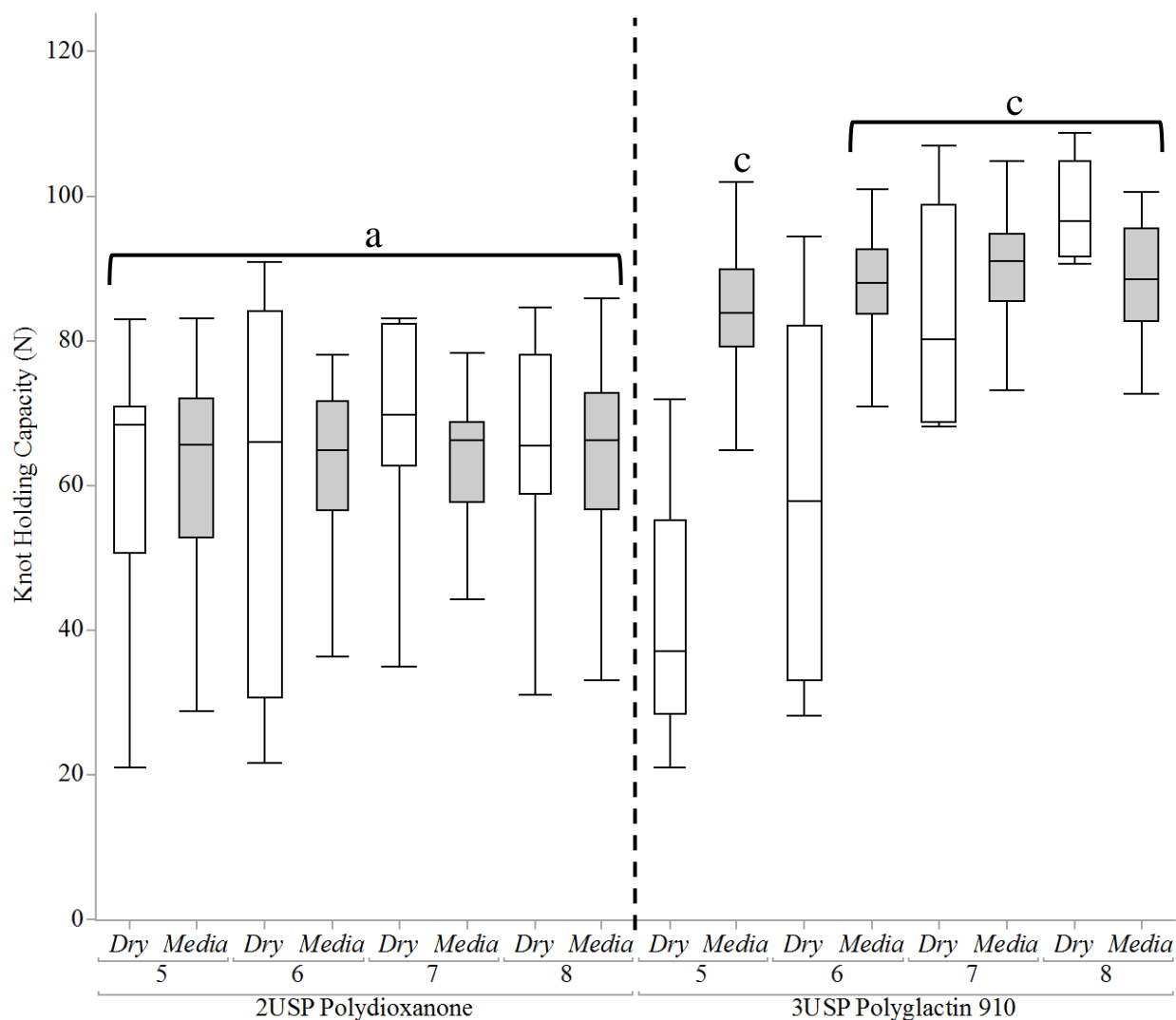

A box plot (median, 25% and 75% quartiles and range) showing the effect of media exposure on the knot holding capacity (KHC) of surgeon's knots tied with either 2 USP polydioxanone or 3 USP polyglactin 910 with 5,6,7 or 8 throws. The white box plots represent knots tied with dry suture. The grey box plots represent the knots tied with suture exposed to media. Boxplots annotated with different letters within each suture material, indicate groups that are statistically different ($p \leq 0.05$).

Figure 4.5

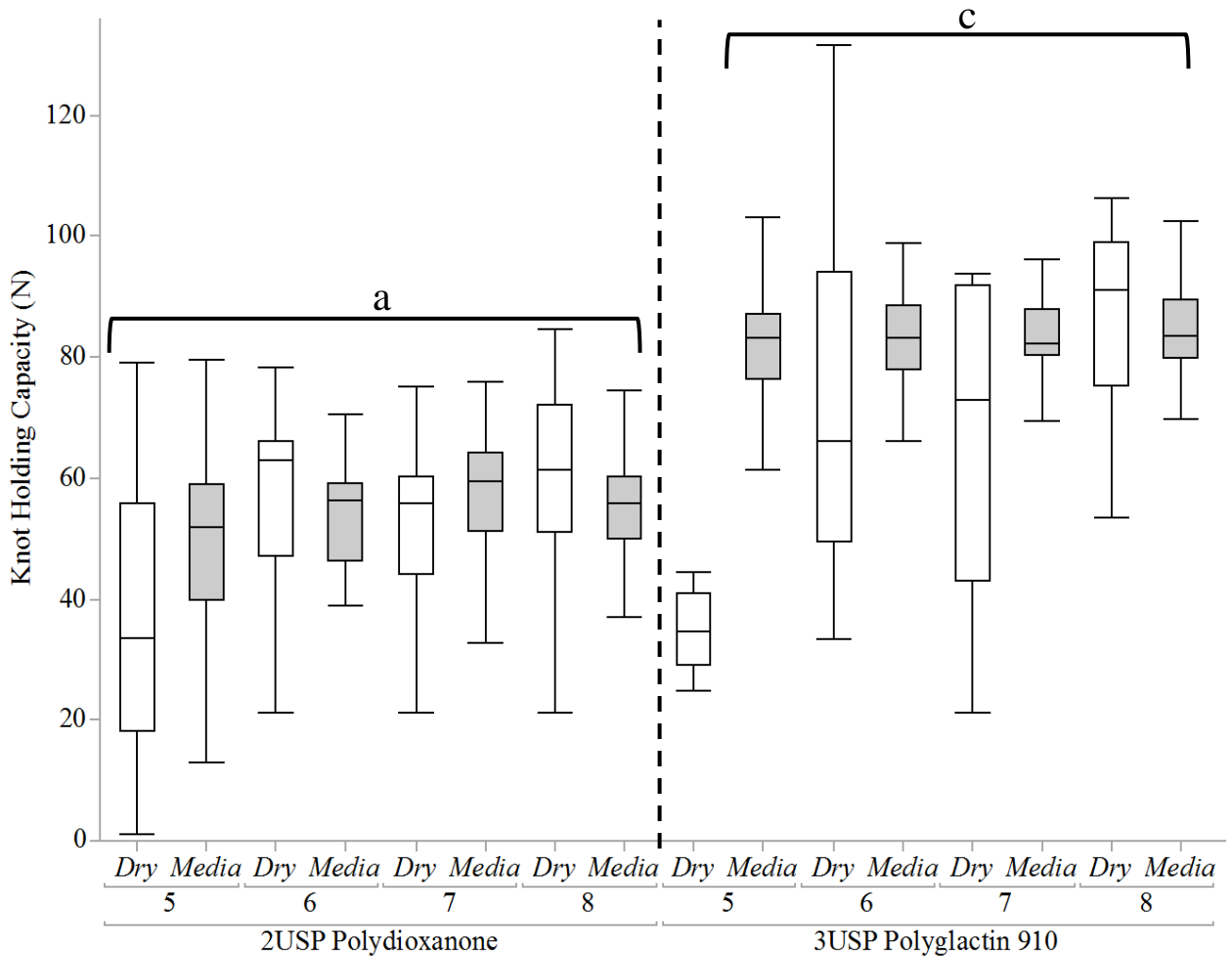

A box plot (median, 25% and 75% quartiles and range) showing the effect of media exposure on the knot holding capacity (KHC) of square knots tied with either 2 USP polydioxanone or 3 USP polyglactin 910 with 5,6,7 or 8 throws. The white box plots represent knots tied with dry suture. The grey box plots represent the knots tied with suture exposed to media. Boxplots annotated with different letters within each suture material, indicate groups that are statistically different ($p \leq 0.05$).

Figure 4.6

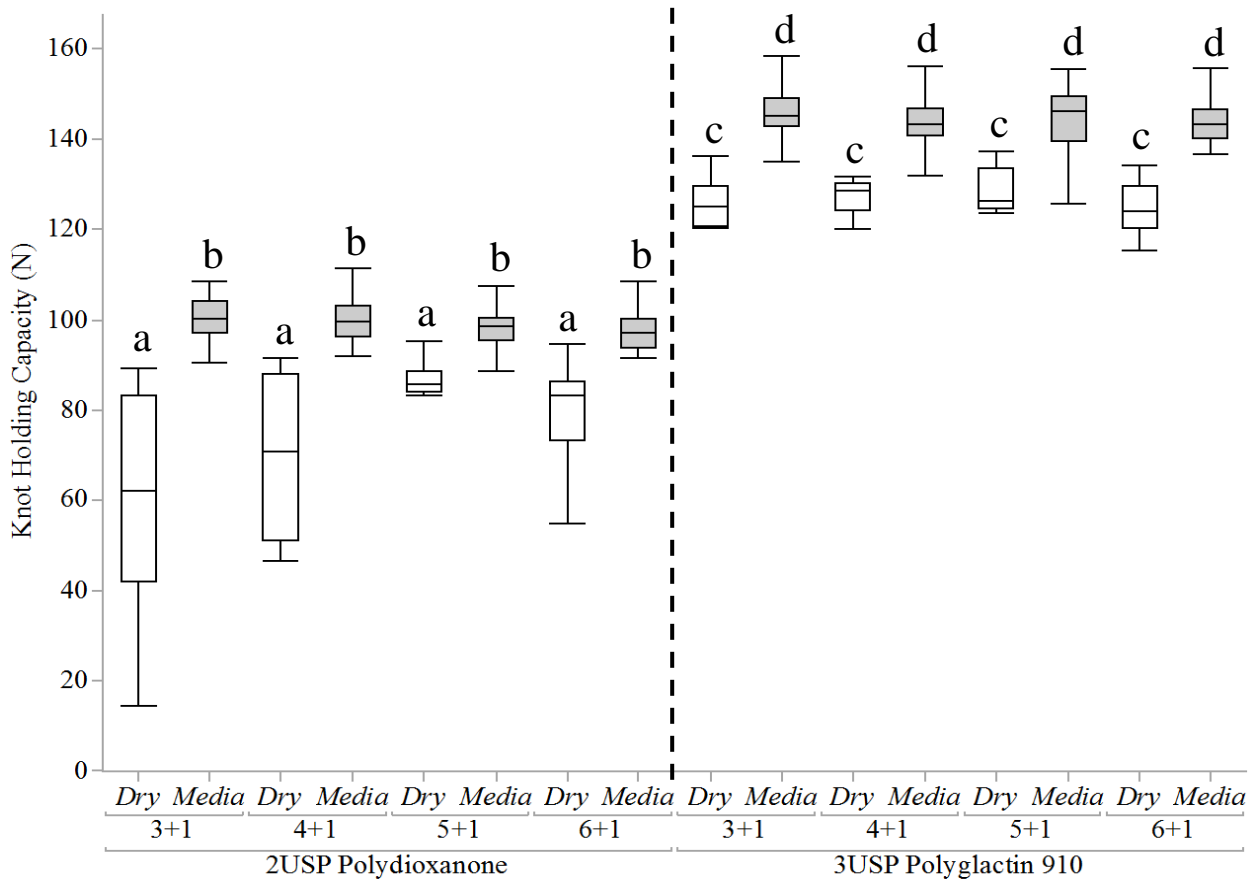

A box plot (median, 25% and 75% quartiles and range) showing the effect of media exposure on the knot holding capacity (KHC) of Aberdeen knots tied with either 2 USP polydioxanone or 3 USP polyglactin 910 with 3,4,5 or 6 throws each with 1 turn. The white box plots represent knots tied with dry suture. The grey box plots represent the knots tied with suture exposed to media. Boxplots annotated with different letters indicate groups that are statistically different ($p \leq 0.05$).

Figure 4.7

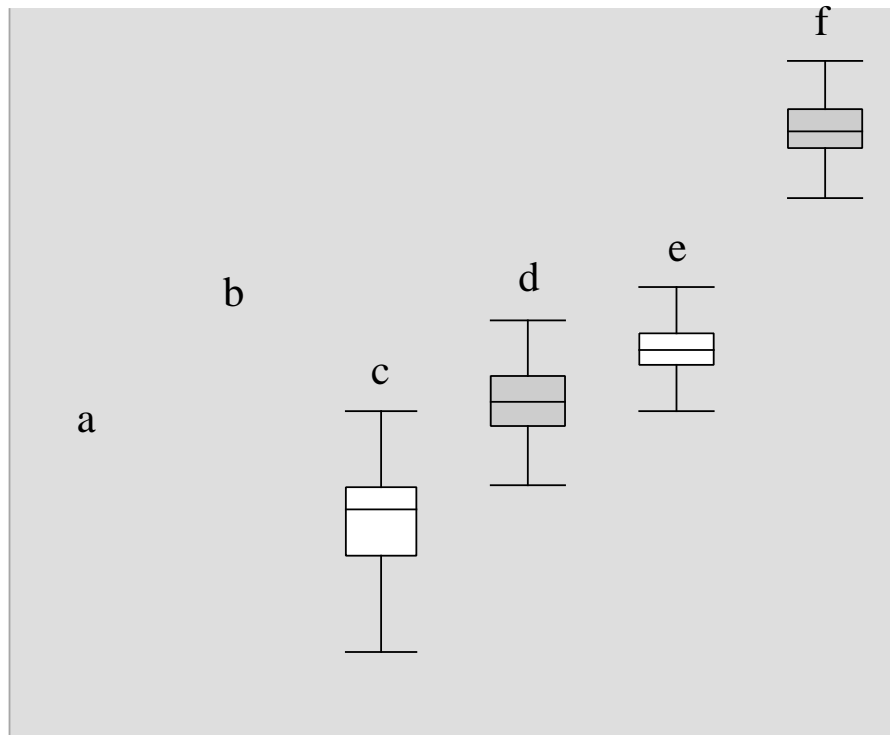

A box plot (median, 25% and 75% quartiles and range) showing the effect of suture material on the knot holding capacity (KHC) of square, surgeon's and Aberdeen knots tied with either 2 USP polydioxanone or 3 USP Polyglactin 910 exposed to 1 of the 4 media studied. The white box plots represent knots tied with 2USP Polydioxanone. The grey box plots represent the knots tied with 3USP Polyglactin 910. Boxplots annotated with different letters indicate groups that are statistically different ($p \leq 0.05$).

Figure 4.8

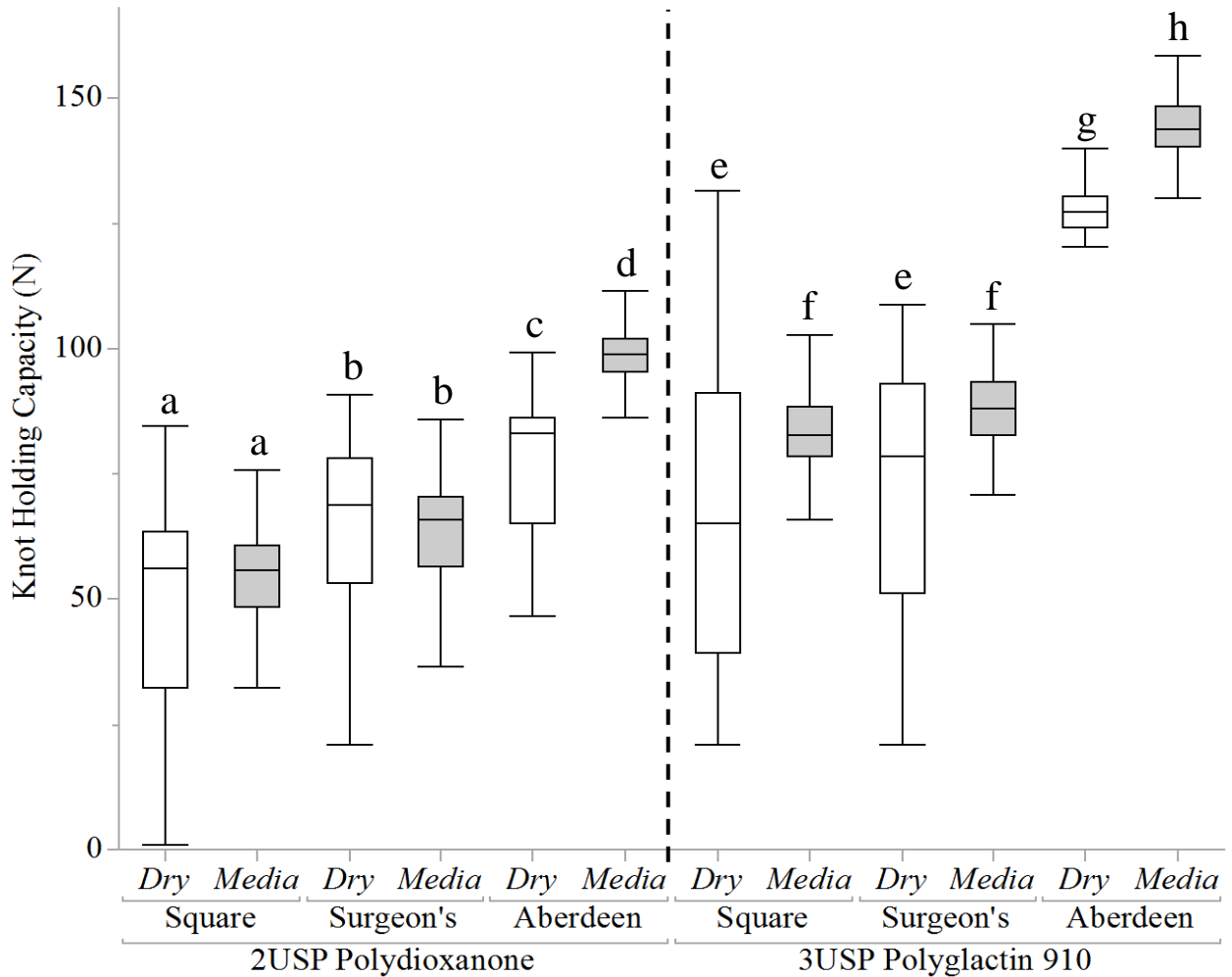

A box plot (median, 25% and 75% quartiles and range) showing the effect of media exposure on the knot holding capacity (KHC) of square, surgeon's and Aberdeen knots tied with either 2 USP polydioxanone or 3 USP polyglactin 910. The white box plots represent knots tied with dry suture. The grey box plots represent the knots tied with suture exposed to media. Boxplots annotated with different letters indicate groups that are statistically different ($p \leq 0.05$).

Figure 4.9

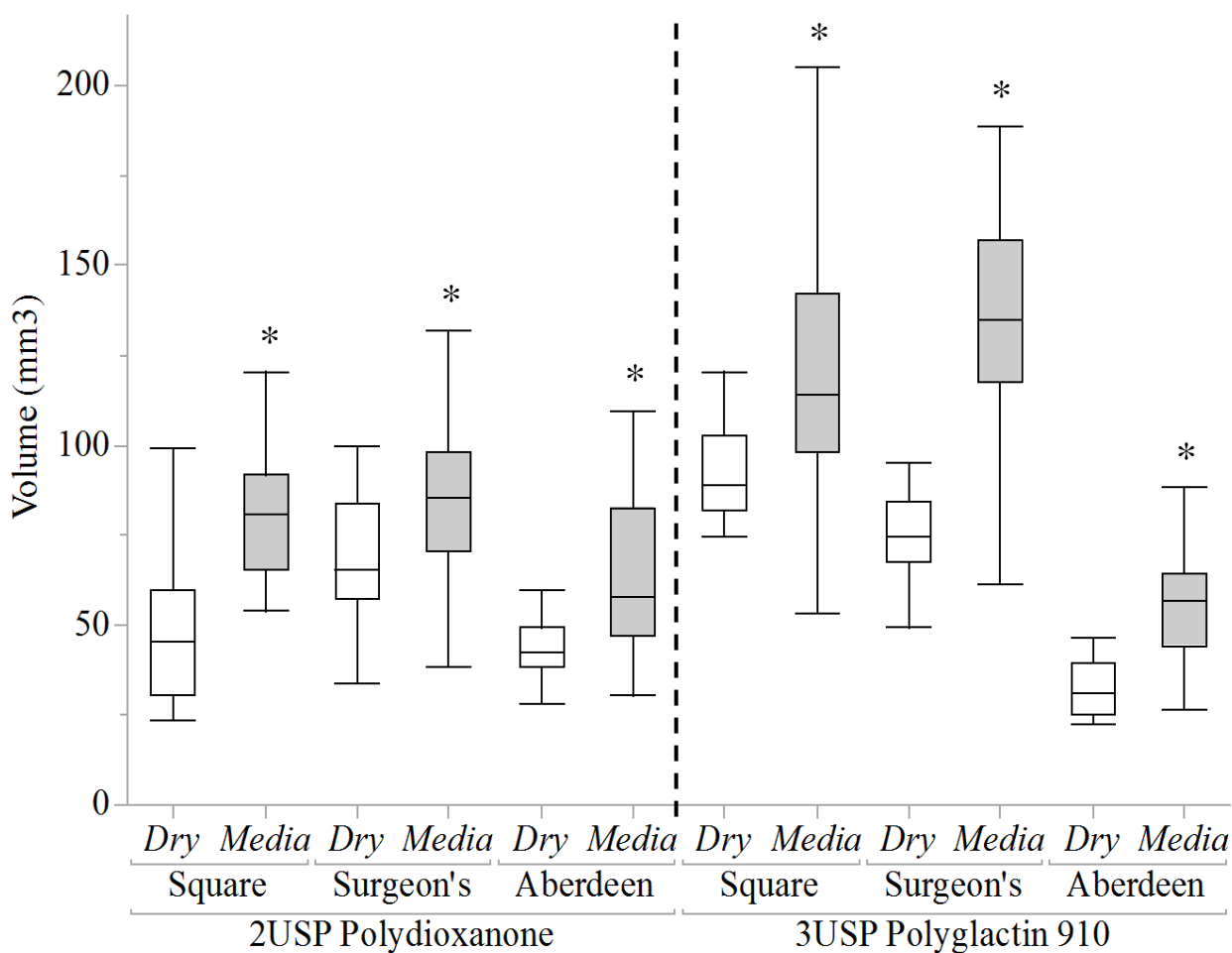

A box plot (median, 25% and 75% quartiles and range) showing the effect of media exposure on knot volume of square, surgeon's and Aberdeen knots tied with either 2 USP polydioxanone or 3 USP polyglactin 910. The white box plots represent knots tied with dry suture. The grey box plots represent knots tied with media exposed suture. Media exposed knots were always significantly larger than their dry equivalents ($P < 0.039$). A significant increase in the media exposed variant's knot volume when compared to its dry variant volume is represented by an asterisk (*).