

WRIST EXTENSION COUNTER-MOMENT FORCE EFFECTS ON MUSCLE  
ACTIVITY OF THE ECR WITH GRIPPING: IMPLICATIONS FOR  
LATERAL EPICONDYLAGIA

Except where reference is made to the work of others, the work described in this dissertation is my own or was done in collaboration with my advisory committee. This dissertation does not include proprietary or classified information.

---

Brian Jude Campbell

Certificate of Approval:

---

Mary Rudisill  
Professor  
Health and Human Performance

---

Wendi H. Weimar, Chair  
Associate Professor  
Health and Human Performance

---

Dave Pascoe  
Professor  
Health and Human Performance

---

J. Troy Blackburn  
Assistant Professor  
Health and Human Performance

---

Stephen L. McFarland  
Dean  
Graduate School

WRIST EXTENSION COUNTER-MOMENT FORCE EFFECTS ON MUSCLE  
ACTIVITY OF THE ECR WITH GRIPPING: IMPLICATIONS FOR  
LATERAL EPICONDYLAGIA

Brian Jude Campbell

A Dissertation

Submitted to

the Graduate Faculty of

Auburn University

in Partial Fulfillment of the

Requirements for the

Degree of

Doctor of Philosophy

Auburn, Alabama  
December 15, 2006

WRIST EXTENSION COUNTER-MOMENT FORCE EFFECTS ON MUSCLE  
ACTIVITY OF THE ECR WITH GRIPPING: IMPLICATIONS FOR  
LATERAL EPICONDYLAGIA

Brian Jude Campbell

Permission is granted to Auburn University to make copies of this dissertation at its discretion, upon request of individuals or institutions and at their expense.  
The author reserves all publication rights.

---

Signature of Author

---

Date of Graduation

## VITA

Brian Jude Campbell, son of Pat and Yvonne Campbell, was born on December 2, 1976, in Abbeville, Louisiana. He graduated from Delcambre High School in Delcambre Louisiana in 1995. He graduated from the University of Louisiana at Lafayette with a Bachelors of Science, in 1999. He worked as a student athletic trainer for various sport programs at the University. He then accepted a graduate athletic training assistantship at the University of Southern Mississippi in 2000, graduating with a Masters of Science in Exercise Science in 2002. In August 2002, he entered graduate school at Auburn University in Auburn, Alabama.

DISSERTATION ABSTRACT

WRIST EXTENSION COUNTER-MOMENT FORCE EFFECTS ON MUSCLE  
ACTIVITY OF THE ECR WITH GRIPPING: IMPLICATIONS FOR  
LATERAL EPICONDYLAGIA

Brian Jude Campbell

Doctor of Philosophy, December 15, 2006  
(M.S., University of Southern Mississippi, 2002)  
(B.S., University of Louisiana at Lafayette, 1999)

118 Typed Pages

Directed by Wendi H. Weimar

Studies have suggested that the muscle most commonly associated with lateral epicondylalgia (tennis elbow) is the extensor carpi radialis (ECR). Gripping elicits pain in persons symptomatic with this condition. The common factor between recreational, occupational, and daily living activities that lead to lateral epicondylalgia is gripping. The isometric grip creates a wrist flexion moment due to the finger flexor tendons crossing the wrist joint. Our wrist extensor muscles must counter this wrist flexion moment created by our finger flexors if the wrist is to remain in a neutral posture. Gripping then naturally innervates the wrist extensor muscles, which attach on the lateral epicondyle. The lateral epicondyle is the point of irritation for persons symptomatic with lateral epicondylalgia. If the wrist was afforded an external wrist extension counter-moment force, would the internal wrist extensors be less active? Less activity would be

beneficial as it would lead to less cumulative stress being placed on the lateral epicondyle where the ECR originates. The purpose of this research is to determine if the presence of an external counter-moment force will decrease the activity of the ECR during various gripping activities in asymptomatic and symptomatic persons. As the ECR is the primary muscle associated with TE, any significant decrease noted in the EMG activity of the ECR could lead to promising advances in the etiology of TE. Understanding the effects of an external counter-moment force on the muscle activity associated with TE, would lead to advances in rehabilitation, symptom relief braces, and eventually lead to a better understanding of how this pathology originates and persists.

Forty-eight subjects, 10 male and 10 female for each asymptomatic section, and 4 male and 4 female for the symptomatic section volunteered as participants in this study. Participants in the max counter-moment force section maximally gripped while also pushing against a static counter-moment force device at various levels of maximal wrist extension counter-moment force intensity (0%, 25%, 50%, 75%, 100%). Participants in the task counter-moment force section gripped three items (hammer, tennis racket, and gallon of tea). The grip force was measured and then matched in the subsequent trial where an external wrist extension counter-moment force was applied. Participants in the symptomatic section maximally gripped a handle then rated their perceived discomfort. After a rest, they again maximally gripped a handle which had a wrist extension counter-moment force then rated their perceived discomfort. Counter-moment forces were measured using the AMTI™ OR6-7-1000 Biomechanics Sport Platform®. Muscle activity was measured using the Noraxon® Myosystem 1200™ electromyography system. The counter-moment force which was supplied during the task and symptomatic

counter-moment force sections was supplied by the Marcy<sup>®</sup> Wedge<sup>™</sup>. Grip magnitude was measured using the Economical Load & Force System (ELF<sup>®</sup>) by Flexiforce<sup>™</sup>. Repeated measures ANOVA's were used for each research section.

Results indicate in the maximum counter-moment force study that any counter-moment force intensity (25%, 50%, 75%, 100%) while maximally gripping significantly lowers muscle activity of the ECR muscle compared to maximal gripping alone. There is no significant difference however between counter-moment force trials (25%, 50%, 75%, 100%). Results also indicate that the presence of a wrist extension counter-moment force decreases muscle activity of the ECR muscle when gripping a hammer, tennis racket, and gallon of tea.

These findings provide the basis for future investigations into the role of wrist extension counter-moment forces and how the application of these may alleviate symptoms of lateral epicondylagia.

## ACKNOWLEDGMENTS

I sincerely thank every person over the years that have assisted in my growth as an athletic trainer, student, teacher, and person. I would like to thank my committee as well as the faculty in the Department of Health and Human Performance for the tremendous educational experience they have afforded me. I would like to specifically thank Dr. Wendi Weimar for her mentorship as a teacher, researcher, advisor, and friend. I would also like to thank Dr. Mary Rudisill, Dr. Dave Pascoe, and Dr. J. Troy Blackburn for their help specifically during the past year.

Above all, I would like to thank my family; Mom, Dad, Jason, Melissa, For all of their wisdom, support, and love. I would like to specifically thank my wife Luci for her unyielding love and support during the last 4 years. Without the safety net of my family, I would not have succeeded in becoming the student, teacher, and person I am today. I love you all.



Style manual or journal used: Publication Manual of the American Psychological Association, 5<sup>th</sup> Edition

Computer Software used: Microsoft Word for Windows 2000, Microsoft Excel, SPSS for Windows (Version 11.5)

## TABLE OF CONTENTS

LIST OF FIGURES.....	xiii
LIST OF TABLES.....	xv
CHAPTER I. INTRODUCTION.....	1
Gripping and Wrist Extensors.....	3
Statement of the Problem.....	6
Purpose of the Study.....	6
Hypothesis.....	7
Primary Objective.....	7
Operational Definitions.....	8
CHAPTER II. LITERATURE REVIEW.....	10
Wrist and Elbow Anatomy.....	11
Etiology.....	13
Gripping/Grasping.....	19
Muscle Activation.....	23
Reciprocal Inhibition and the ECR Shift.....	24
Tonic and Phasic Muscles.....	27
Active and Passive Insufficiency.....	29
Mechanical Insufficiency.....	30
Neurological Insufficiency.....	33

Grippers Elbow.....	34
Previous Research on Counter-moment Forces.....	36
CHAPTER III. METHODS.....	39
Participants.....	39
Equipment.....	41
Procedures.....	44
Statistical Analysis.....	48
Max Counter-Moment Force.....	48
Task Counter-Moment Force.....	49
Symptomatic Counter-Moment Force.....	49
CHAPTER IV. RESULTS.....	57
Max Counter-Moment Force.....	57
Task Counter-Moment.....	58
Symptomatic Counter-Moment Force.....	59
CHAPTER V. DISCUSSION.....	73
Maximum Counter-Moment.....	73
Task Counter-Moment.....	75
Tennis.....	76
Hammer.....	76
Gallon of Fluid.....	77
Symptomatic Counter-Moment Force.....	79
Tennis Elbow.....	81
Future Research.....	82

Limitations.....	85
Summary.....	87
REFERENCES.....	89
APPENDIX A. Max Counter-Moment Force .....	96
APPENDIX B. Task Counter-Moment .....	99
APPENDIX C. Preliminary Medical Questionnaire.....	102

## LIST OF FIGURES

Figure 1. Anatomical Insertion of the ECR into the Base of the 3 <sup>rd</sup> Metacarpal.....	50
Figure 2. AMTI <sup>™</sup> OR6-7-1000 Biomechanics Sport Platform <sup>®</sup> .....	51
Figure 3. Noraxon EMG System <sup>®</sup> .....	52
Figure 4. Marcy Wedge <sup>®</sup> .....	53
Figure 5. ELF <sup>®</sup> System.....	54
Figure 6. Modified Borg Scale.....	55
Figure 7. EMS-1C <sup>™</sup> portable stimulator unit by Med Labs <sup>®</sup> .....	56
Figure 8. Comparison of All conditions for manual counter-moment force.....	61
Figure 9. Maximum grip of handle without counter-moment force and with 25% maximal counter-moment force.....	61
Figure 10. Maximum grip of handle without counter-moment force and with 50% maximal counter-moment force.....	62
Figure 11. Maximum grip of handle without counter-moment force and with 75% maximal counter-moment force.....	62
Figure 12. Maximum grip of handle without counter-moment force and with 100% maximal counter-moment force.....	63

Figure 13: Maximum grip of handle with 25% counter-moment force and with 50% maximal counter-moment force.....	63
Figure 14: Maximum grip of handle with 25% counter-moment force and with 75% maximal counter-moment force.....	64
Figure 15: Maximum grip of handle with 25% counter-moment force and with 100% maximal counter-moment force.....	64
Figure 16: Maximum grip of handle with 50% counter-moment force and with 75% maximal counter-moment force.....	65
Figure 17: Maximum grip of handle with 50% counter-moment force and with 100% maximal counter-moment force.....	65
Figure 18: Maximum grip of handle with 75% counter-moment force and with 100% maximal counter-moment force.....	66
Figure 19: Grip of tennis racket handle with and without counter-moment force.....	66
Figure 20: Grip of a hammer with and without counter-moment force.....	67
Figure 21: Grip of a gallon of fluid with and without counter-moment force.....	67
Figure 22: Perceived pain with and without counter-moment force.....	68
Figure 23: Mean EMG with and without counter-moment force.....	68

## LIST OF TABLES

Table 1. Statistical analysis for maximal counter-moment force.....	69
Table 2: Paired sample <i>t</i> test follow up analysis for all possible within subject combinations.....	70
Table 3: The means and standard deviations for each implement with and without the external counter-moment force.....	71
Table 4: The <i>F</i> scores and <i>p</i> values for each implement with and without the external counter-moment.....	71
Table 5: Paired samples <i>t</i> -test for Symptomatic Counter-moment force study (Perceived Pain).....	71
Table 6: Paired samples <i>t</i> -test for Symptomatic Counter-moment force study (EMG).....	72

## CHAPTER I. INTRODUCTION

Studies have suggested that the muscle most commonly associated with lateral epicondylalgia (tennis elbow) is the extensor carpi radialis brevis (ECRB) (Snijders 1987; Roetert 1995; Ljung 1999; Ciccotti 2001). Ciccotti and Charlton (2001) reported that irritation of the ECR, of which the ECRB is a part, is a contributing factor in 91 % of patients that presented symptoms of tennis elbow (TE). Furthermore, in 64 % of patients with TE the proximal tendon of the ECR was the only muscle that showed signs of damage (Ciccotti 2001). Though TE was first reported in 1882 (Ciccotti 2001), the etiology of the condition is not fully understood. Since the ECR is a wrist extensor, a common theory suggests that the repetitive, eccentric contraction involved in some activities, such as racket sports or the use of tools, can lead to cumulative trauma of the ECR (Henning 1992; Ciccotti 2001). This hypothesis is supported by the onset of pain elicited with backhand tennis strokes in recreational sports, as well as other wrist movements in occupational settings (Ljung 1999). Nonetheless, this explanation of TE etiology leaves many questions unanswered. For example, if eccentric loading of the wrist extensors is the causal mechanism of injury, then why, of the seven muscles involved in wrist extension, is the ECR the muscle most commonly affected? Furthermore, if the wrist extensors are the muscles responsible for this injury, then why do so many sufferers of lateral epicondylalgia complain of pain when opening a door,



picking up a gallon of milk, or shaking hands? In addition, why do individuals with jobs such as welding, which involves little eccentric loading of the wrist extensors, report symptoms consistent with tennis elbow? Pain induced from non-wrist movements such as gripping alone challenges the notion that tennis elbow is caused solely by eccentric loading of the wrist extensors. To date, an underlying mechanism has yet to be explicitly defined for the onset of TE, however circumstantial evidence suggests that the irritation of the ECR may be due to issues associated with gripping.

Much of the research in the area of lateral epicondylagia focuses on etiologies pertaining to tennis (Henning 1992; Blackwell 1994; Bylak 1998). This can be attributed to the catch-all phrase “Tennis Elbow”. TE is synonymous with lateral epicondylagia, however only 5 – 10 % of all reported TE cases are associated with individuals who play tennis (Gruchow 1979). Most of the reported cases (60%) of TE are from occupational settings (Gruchow 1979). Since TE is the most common term for the condition of lateral epicondylagia, etiology theory has focused mostly on tennis stroke mechanics. In fact, Henning (1992) and Ciccotti (2001) have suggested that the backhand stroke, eliciting pain in the lateral epicondyle, leads to the practical theory of eccentric wrist extensor overload as a prominent etiology of TE (Cyriax 1939; Durbin 1966; Coonrad 1973; Murtagh 1988). Other tennis driven research associated with TE includes vibration transfer from the ball-racket interface to the lateral epicondyle, stroke mechanics (Boyer 1999), as well as comparison of novice and advance player’s techniques (Nirschl 1973; Cooney 1984; Kohn 1984; Kelley 1994). Unfortunately, most published articles on occupational TE focus mainly on surgical means or symptom relief, rehabilitation, and incidence, and not specific etiology. Finding a common ground between recreational and

occupational signs and symptoms of TE may yield a clue into the true onset of this pathology.

According to the American Academy of Orthopaedic Surgeons, the most common recreational activities in which TE is reported are: tennis, racquetball, squash, and fencing (Jobe 1994). In occupational settings, meat cutting, plumbing, painting, raking, and weaving make up most of the reported cases of TE (Jobe 1994). The eccentric nature of the racket backhand as well as vibration theories, which are often used to explain the onset of TE, cannot be applied to occupational settings where there is mostly static gripping and minimal dynamic multi-directional wrist movement. One factor that is consistent in both the recreational and occupational precursors to TE is the gripping of various instruments used in each activity. Gripping is required to operate a racket, lance, knife, wrench, welding torch, paintbrush, rake, and other tools. Grip mechanics however can vary greatly. Grip mechanics, therefore, should be studied in greater detail, as all reported activities, recreational and occupational, have gripping as a common factor, but the mechanics of this grip however varies.

#### Gripping and wrist extensors

The isometric grip creates a wrist flexion moment due to the finger flexor tendons crossing the wrist joint. The muscles responsible for this isometric grip are the finger flexors extrinsic (flexor digitorum, superficialis and profundus,) and intrinsic (lumbricals and interossei). The extrinsic finger flexors originate on the medial epicondyle and contribute to wrist flexion moment, where the intrinsic muscles contribute to finger flexion only. Due to the medial origin of these muscles, contraction of these muscles

alone does not appear to contribute directly to injury to the lateral side of the elbow. When a recreational tennis player, or occupational meat cutter grips a racket/tool, the finger flexors curl the fingers around the respective handles. When the fingers are isometrically contracted around the handle, the insufficiency of the finger flexors as wrist flexors is eliminated, and a wrist flexion moment can be achieved via the finger flexors. To keep the wrist in a more neutral posture during activities that require gripping, the wrist extensor muscles must be recruited to counter the wrist flexor moment created by the finger flexors (Bunnell 1944; Cabrera 1986; Snijders 1987). While there are seven muscles that work as wrist extensors, researchers cannot explain why the ECR is the muscle most associated with tennis elbow symptoms. The specific role of the ECR in providing extension counter-moment force may be explained through reciprocal inhibition.

Isometric contractions elicit the highest amount of reciprocal inhibition, causing the antagonistic muscles to be reciprocally inhibited (Rauch 1989). In gripping tasks for example, the finger flexors are constantly contracted isometrically around the handle of the tool, in theory, subjecting the antagonistic extensor digitorum (ED), to this type of inhibition. Since the ED is a wrist extensor, inhibiting its activity requires a greater contribution from the synergistic extensor muscles that cross the wrist joint for a given load. The ECR is an efficient compensator because it possesses the longest moment arm of the remaining wrist extensors (Loren 1995). Furthermore, due to the attachment of the ECR on the base of the third metacarpal, the muscle tendon is in an optimal mechanical position to provide this wrist extension counter-moment force (See figure 1). This

compensatory action of the ECR via ED inhibition with gripping may be a contributing factor to the irritation of the lateral epicondyle (ECR origin) in tennis elbow.

Our unpublished pilot data have confirmed ECR compensation for ED decreases noted during gripping. When gripping ED mean EMG significantly decreases while ECR activity significantly increases when compared to wrist extension with fingers extended. Furthermore, these data have shown that ECR activity is also linked to grip intensity, with increased intensity eliciting high ECR activity (counter-moment force). This suggests that over gripping recreational and occupational tools may play a role in TE.

Campbell and Weimar (unpublished) suggest that the tennis backhand stroke is not directly responsible for increased stress on the ECR. With regard to undo stress placed on the ECR during an eccentrically isometric load, no significant difference in mean EMG was noted between maximal gripping alone (one internal wrist flexion moment) and maximal gripping combined with maximal wrist extension (one internal and one external wrist flexion moment). The significant decrease in ED EMG activity during gripping, when compared to gripping with loaded wrist extension, suggests that the ECR has assistance from the ED when an external wrist extension is needed during gripping. This allows the ECR activity to remain the same. The ED does not assist with gripping alone due to increased reciprocal inhibition from the finger flexors. When an external wrist extension is employed, the ED does not succumb to as much inhibition due to its role in active wrist extension. These findings indicate the importance of isometric gripping alone on the cumulative stress of the ECR muscle.

Our body has a natural way of maintaining a neutral wrist posture, even in the face of the various internal and external wrist flexion moments that can be induced during

gripping. The question then arises, if the body was given an external wrist extension counter-moment force, would the internal wrist extensors be less active? Less activity would be beneficial as it would lead to less cumulative stress being placed on the lateral epicondyle where the ECR originates. Pilot work (unpublished) done on this topic has shown promising results. ECR activity tends to decrease when a maximal external counter-moment force is applied during maximal gripping. Occupational and recreational persons however do not always use a maximal grip, and within each person, grip magnitude will vary. This leads to the question, would a supportive external wrist extension counter-moment force have an effect on various task dependant-gripping magnitudes? In theory, if ECR activity were decreased with gripping tasks combined with a supportive external wrist extension counter-moment force, persons symptomatic with TE would report less pain due to the decreased stress on the muscle origin. Therefore, the purpose to this study is to investigate the influence of external wrist extension counter-moment forces on ECR muscle activity of symptomatic and asymptomatic persons below the age of forty years old.

#### Statement of Purpose

The purpose of this research was to determine if the presence of an external counter-moment force will decrease the activity of the ECR during gripping activities. As the ECR is the primary muscle associated with TE, any significant decrease noted in the EMG activity of the ECR could lead to promising advances in the etiology of TE. Understanding the effects of an external counter-moment force on the muscle activity

associated with TE, would lead to advances in rehabilitation, symptom relief braces, and eventually lead to a better understanding of how this pathology originates and persists.

## Hypotheses

### *Primary objective - Maximal counter moment force*

(1) An external, supportive maximal counter moment force will decrease ECR activity during maximal gripping compared to gripping alone.

### *Primary objective – Counter moment force and daily activities*

(1) An external counter moment force will decrease the ECR activity while the participant grips everyday items compared to gripping alone (standardized to max grip):

- (a) Tennis racket handle
- (b) Hammer
- (c) A gallon of fluid

### *Primary objective – Counter moment force and symptomatic people*

(1) An external counter moment force will decrease the ECR activity and pain associated with gripping, in individuals identified as symptomatic with TE compared to maximal gripping alone.

## Definitions

*Active insufficiency:* A multi joint muscle cannot efficiently shorten at both ends at the same time.

*Extensor Carpi Radialis Shift (ECR Shift):* When gripping, the ECR increases in activity to compensate the decrease in the Extensor Digitorum muscle associated with reciprocal inhibition from the finger flexors.

*Extensor Carpi Radialis (ECR):* Muscle responsible for concentrically extending as well as radial deviating the wrist joint. Formed by the Extensor carpi radialis brevis and Extensor carpi radialis longus.

*Extensor Carpi Radialis brevis (ECRB):* Muscle responsible for concentrically extending as well as radial deviating the wrist joint. Commonly associated with tennis elbow. Combines with the extensor carpi radialis longus to form the ECR

*Extensor Carpi Radialis longus (ECRL):* Muscle responsible for concentrically extending as well as radial deviating the wrist joint. Commonly associated with tennis elbow. Combines with the extensor carpi radialis longus to form the ECR.

*Extensor Digitorum:* Muscle responsible for concentrically extending the fingers.

*Flexor Digitorum Profundus:* Muscle responsible for concentric flexion of fingers (2<sup>nd</sup> – 5<sup>th</sup> proximal and distal interphalangeal joints) and wrist flexion.

*Flexor Digitorum Superficialis:* Muscle responsible for concentric flexion of fingers (2<sup>nd</sup> – 5<sup>th</sup> metacarpal-phalangeal joint) and wrist flexion.

*Internal Counter-Moment force:* Co-contraction of an antagonistic muscle or muscles to counter the joint motion of an agonist muscle or muscles.

*Mechanical insufficiency:* Occurs when a multi-articular muscle does not have the ability (mechanically) to apply optimal force at more than one joint simultaneously.

*Muscle Insertion:* Area of muscle attachment on bone distal to the muscle origin

*Muscle Origin:* Area of muscle attachment onto bone proximal to the muscle insertion.

*Neurological Insufficiency:* When a multi-articular muscle must lessen its activity neurologically to disallow one, or more, of the articulating joint motions to occur.

*Passive Insufficiency:* The inability of a muscle to develop tension optimally due to rapid shortening of the myofilaments at both ends simultaneously.

*Reciprocal inhibition:* The ability of an active agonist muscle to reflexively lower muscle activity of its antagonist to lessen the antagonist internal counter-moment.

*Supportive External Counter-Moment Force:* An external (non-muscular) antagonist device, which counters the joint motion of an agonistic muscle or muscles.

*Symptomatic:* Persons demonstrating the symptoms of tennis elbow including pain and tenderness of the lateral epicondyle diagnosed by a physician.

*Tennis elbow/Lateral epicondylitis:* Clinical pathology indicated by pain and tenderness over the lateral epicondyle due to irritation of the origin of the extensor carpi radialis tendon.

*Wrist Extension Moment:* The specific joint force applied at the wrist by the wrist extensor muscles.

*Wrist Flexion Moment:* The specific joint force applied at the wrist by the wrist flexor muscles.



## CHAPTER II. LITERATURE REVIEW

Tennis Elbow (TE) is a catch all term that has become synonymous for pain on the lateral epicondyle. This pathology is thought to be associated with chronic stress on the muscles that start on this common origin. Lateral epicondylitis, lateral epicondylalgia, and degenerative tendonosis all refer to the term “tennis elbow” (Henning 1992; Blackwell 1994; Vicenzino 1996). The most prevalent of these terms is lateral epicondylitis. Lateral describes the location (lateral elbow) and epicondylitis refers to inflammation of the epicondyle. Inflammation is characterized with localized swelling, as well as physiologically inflammatory markers. However, neither swelling nor the physiological markers (histamine and prostaglandins) are present in TE, leading some researchers to refer to this condition as lateral epicondylalgia (LE) instead of epicondylitis (Henning 1992; Vicenzino 1996).



Picture A

<http://www.all-about-tennis.com/images/elbmusl2.gif>

### *Wrist and Elbow Anatomy*

When one is rehabilitating an injury, a common suggestion is to not only rehabilitate the area of injury, but also focus on the joint proximal and distal. Since TE is isolated on the lateral epicondyle of the elbow, this joint as well as the wrist, joint will be explored in greater detail. This section will focus on bony articulations, joint types/actions, ligament stability, and muscle arrangement.

The elbow is a gynglymous joint (Rauch 1989) composed of the humerus and the ulnar bones. Gynglymous joints are uniaxial hinge joints. The stability of the elbow joint is maintained medially by the ulnar collateral ligament, and laterally by the radial collateral ligament. End point stability is maintained anteriorly by the soft endpoint of elbow flexion, while posterior is supplied by the hard end point of the olecranon process

of the ulnar and the olecranon fossa of the humerus. The elbow joint allows for flexion and extension only. Muscles that cross the elbow joint include the elbow flexors (biceps brachii, brachialis, and brachioradialis) and extensors (triceps brachii, and anconeus).

The proximal radio-ulnar joint is commonly mistaken as part of the elbow joint. The radio-ulnar joint is classified as a uni-axial trochoid or pivot joint, and allows for pronation and supination (Rasch 1989). The joint is composed of the head of the radius and the radial notch of the ulna. The stability of the radio-ulnar joint is maintained via the annular ligament. This ligament wraps around the radial head, maintaining its articulation with the ulna, allowing the radial head to rotate about the ulna. Muscles that cross the proximal radioulnar joint include the pronators (pronator quadratus, pronator teres, brachioradialis) and the supinators (biceps brachii, brachioradialis, and supinator).

The wrist joint is considered an ellipsoidal joint (Rauch 1989). Ellipsoidal joints are similar to condyloid joints in that they are both bi-axial. However, ellipsoidal joints do not allow for passive rotation as is the case for the 2<sup>nd</sup>-5<sup>th</sup> metacarpal-phalangeal joints in the condyloid joint. The wrist joint is composed of the distal radius, distal ulna, and proximal carpal bones. The ways these bones articulate allows wrist joint flexion and extension in the sagittal plane, while also allowing for radial and ulnar deviation in the frontal plane. The muscles, which cross the wrist joint, include the wrist flexors (palmaris longus, flexor carpi radialis, flexor carpi ulnaris, flexor digitorum superficialis, and flexor digitorum profundus), and wrist extensors (extensor carpi radialis, extensor digitorum, and extensor carpi ulnaris). Selective flexor and extensor muscles working synergistically achieve radial and ulnar deviation. For example, concentric radial

deviation is achieved by both the flexor and extensors carpi radialis (longis and brevis), while concentric ulnar deviation is produced by the flexor and extensor carpi ulnaris.

### *Etiology*

Lateral epicondylalgia is a term that is used to describe degenerative tendonosis. The term degenerative implies a condition that is the result of chronic overuse or repetition, which is considered to be a contributing factor to TE. Tendonosis is a term that is characterized by the wearing away, degeneration, or necrosis of the tendon. A normal healthy tendon is white in appearance, as well as sturdy in structure. When doctors observe a degenerative tendon, the unhealthy tendon demonstrates a feature called angiofibroblastic degeneration (Verhaar 1993; Ciccotti 2001). The observed tendon does not display a healthy white texture, but rather an unhealthy yellow texture. These degeneration terms shift the standard thought process of tendonitis (inflammation) into more of tendonosis (degeneration) (Ciccotti 2001) based on observation and lack of the normal inflammatory response associated with the suffix “itis”. Inflammation of a tendon is not achieved very easily due to physiological reasons. Tendons do not become inflamed because of their minimal blood supply to the tissues. Highly vascularized structures, such as muscle tissue, can induce an inflammatory response much greater than that of structures with limited blood supply, such as a tendon. This consideration supports the idea that lateral epicondylitis is a misnomer based on name alone. Because tennis elbow has many names, some of which are misleading, the research behind the condition is very broad.

The etiology of TE is open for debate due to the lack of consistency in reporting the pathology in the literature (Jensen 2001; Moore 2002). Since TE was first reported in tennis players (Cyriax 1939) research regarding the etiology has been mainly focused on tennis based factors (Ciccotti 2001). The most commonly suggested culprit of these tennis based factors is eccentric loading of the wrist extensors via repetitive stress (Gruchow 1979; Leach 1987; Jobe 1994). Specifically, the repetitive eccentric loading found in the backhand strokes used in racket sports is thought to be the leading cause (Blackwell 1994; Nirschl 1996; Ciccotti 2001). The backhand stroke however can be performed with either a two handed or one-handed technique. One-handed backhands are associated with TE symptoms where as two-handed TE backhand strokes are not. Less grip force is needed in the two-hand backhand along with forehand providing a counter-moment force to neutralize the flexion moment of the backhand. The one-handed backhand stroke is thought to produce eccentric wrist flexion upon ball contact. The eccentric wrist flexion occurs through muscle action of the wrist extensor muscles, of which the extensor carpi radialis (ECR) is a part. This eccentric loading of the ECR causes damage at the muscle's origin. Although this theory is largely applied only to racket sports such as tennis and racquetball, two important recent findings call this theory into question (Boyer 1999). (1) Most suffers of TE do not play tennis. Cases reported from tennis account for only 5-10% of all TE treated by physicians (Boyer 1999). (2) Campbell and Weimar (unpublished) have demonstrated two findings which question the excess stress on the ECR resulting from eccentric wrist flexion. First, there is no significant difference in the ECR activity between maximal gripping alone compared to maximal gripping combined with maximal eccentrically loaded isometric wrist extension.

This finding shows that gripping alone is just as important a factor as wrist extensor involvement for the ECR muscle activity in backhand racket strokes. Second, the significant increase in ED activity, from the grip with and without wrist extension, explains how the ECR activity can stay similar between gripping alone versus gripping with an external wrist flexion moment. Campbell and Weimar (unpublished) suggest that the ED assists during the eccentric loading phases of the backhand, thus keeping ECR activity relative to that seen in gripping alone. As observed in Picture B, the actual wrist flexion moment created by the racket/ball interaction is minimal compared to the pronation moment created on the radio-ulna joint by the backhand stroke. This suggests that the eccentric load on the wrist extensor muscles may not be as great as previously thought.



Picture B

[http://www.theage.com.au/ffximage/2005/02/23/mark\\_wideweb\\_\\_430x290.jpg](http://www.theage.com.au/ffximage/2005/02/23/mark_wideweb__430x290.jpg)

The backhand of tennis does create an external wrist flexion moment about the wrist, however another factor, which could affect the muscle activity, differentiates the

backhand from the forehand. The forehand stroke forces the tennis handle into the palm of the hand. This surface of the palm does not allow the racket to exit the hand posteriorly for obvious reasons. In the backhand stroke, however, the only mechanism keeping the racket handle in the palm are the fingers anteriorly. The greater the external wrist flexion moment in the backhand, the greater the grip force required to keep the racket from exiting the fingers must be. This is an important factor overlooked with eccentric loading theory of TE in that the greater the wrist flexion moment, the greater need for grip force in the one handed backhand.

Tennis racket vibration is also thought to be a factor in the development of TE (Hatze 1976; Elliott 1982; Henning 1992). In theory, when the racket is in contact with the tennis ball, the vibration of the racket/ball interface is transferred from the racket, through the hand, through the forearm, and eventually onto the lateral epicondyle where the ECR inserts. When gripping, the forearm muscles will be contracted due to the grip and backhand. This muscle tension will decrease the dampening of the vibration caused by the stroke. The more tone in the muscles, the more easily vibration is transferred through the soft tissue. Tennis racket vibrations, which range from 80-200 Hz, have been suggested to contribute to the development of tennis elbow (Henning 1992).

Another theory of TE etiology focuses on the radial head and its direct contact with the extensor muscles on the lateral epicondyle (Moore 2002). Radial head entrapment theory is based on the concept that the muscles that originate on the lateral epicondyle and cross the elbow joint pass over the head of the radius. Since the radial head constantly rotates with pronation and supination, this theory proposes that this chronic grinding of the radial head on the surrounding soft tissue leads to degeneration of

the structures (Moore 2002). There is also the rare occasion of the radial nerve being the structure that is irritated with constant pronation and supination involved with the radio-ulnar joint. This theory does not appear to be applicable to activities that do not require much pronation/supination such as the isometric grip. Gripping alone, in persons symptomatic with TE, induces pain. The radial head does not rotate in this condition. The healing process is an ongoing cycle throughout the body. Structures within the body are in a constant process of damage and repair (Starkey 1993). As long as the body can repair a component before it is damaged again, homeostasis can be maintained (Starkey 1993). Excessive stress to tendons, such as in TE, offers a problem to the normal healing process. Due to the limited blood supply, the repetitive micro damage caused to the tendon can greatly exceed the healing response of this structure. The weaknesses in the tendon caused by cumulative degeneration are termed degenerative tendonosis. Cumulative degeneration takes into account acute tissue damage in relation to time given to repair.

Common tendons that are injured in sports include the biceps tendon, patella tendon, and rotator cuff tendons (Hoppenfeld 1976; Prentice 1999). The tendon most commonly associated with suffers of TE is called the extensor carpi radialis brevis (ECRB) tendon (Boyd 1973; Coonrad 1973; Snijders 1987; Lieber 1997; Boyer 1999; Ciccotti 2001; Mackay 2003). This tendon originates on the lateral epicondyle of the distal humerus and inserts at the base of the 3<sup>rd</sup> metacarpal bone of the hand (Hoppenfeld 1976). The ECRB muscle is commonly referred to the ECR in the literature (Ciccotti 2001). The ECR is a combination of both the ECRB and ECRL muscles. Since both of these muscles have similar function at the wrist, as well as no current technique for



distinguishing the ECRB from the ECRL in surface electromyography, ECR can be substituted for the ECRB. The ECR muscle is most commonly associated with wrist extension as well as radial deviation of the ellipsoidal wrist joint (Thompson 2004). Contributions of this muscle at the elbow are debatable, with, the possibility of limited contribution to elbow flexion at best (Thompson 2004). Synergistic muscles, which aid the ECR in wrist extension, include the extensor carpi ulnaris as well as the extensor digitorum (ED) (Thompson 2004).

The wrist extensor muscles, of which the ECR is a part, are activated when gripping (Bunnell 1944; Snijders 1987). This response is due to many mechanical and physiological factors, which will be broken down individually in the following sections. The ECR is not only active during gripping, but varies its activity based on gripping intensity. Campbell and Weimar (2006 in review) demonstrated that ECR activity increased linearly with grip intensity. This suggests that not only is gripping an important factor of TE etiology, but gripping intensity as well. The literature on gripping has been primarily done on recreational tennis players, and not in occupational settings (Hatze 1976; Watanabe 1979; Elliott 1982). This research has also focused on gripping magnitude, rebound velocities, and vibration of the tennis ball, and not on the activity of the extensor muscles as a wrist counter-moment.

The ECR tendinous origin, unlike other commonly injured tendons in sports, does not receive sufficient rest in between tennis stroke repetitions because of the continuous muscle activity associated with gripping during occupational, recreational, and activities of daily living. The muscle is active as long as the grip is applied; the muscle activity is also directly related to the grip magnitude. Gripping (finger flexors) activates the wrist

extensors as co-contractors automatically. Thus, as long as the fingers are isometrically gripping, the wrist extensors are isometrically co-contracting.

An example of how other commonly injured tendons may have different mechanisms of injury that differ from the ECR lies in pitching. In pitchers, the tendon of the long head of the biceps brachii can become irritated because of the repetitive nature of pitching. The ECR in occupational and recreational settings is usually not rested due to the co-contraction strategy needed with gripping activities. The link between ECR activation and gripping, and thus TE, can be progressively theorized via a number of mechanisms: 1) gripping/grasping, 2) muscle activation, 3) reciprocal inhibition and the ECR shift, 4) tonic and phasic muscles, 5) active and passive insufficiency, mechanical insufficiency, and 6) neurological insufficiency:

### *Gripping/Grasping*

Hamilton and Luttgens (1997) categorize grasping into two main categories. These two main categories are the power grip and precision handling (Luttgens 1997). Precision handling is sometimes called pinching (Snijders 1987). It involves grasping an object with the thumb along with one or two other fingers (Luttgens 1997). This technique is required for fine motor tasks where detail and precision are the goals of grasping an instrument.

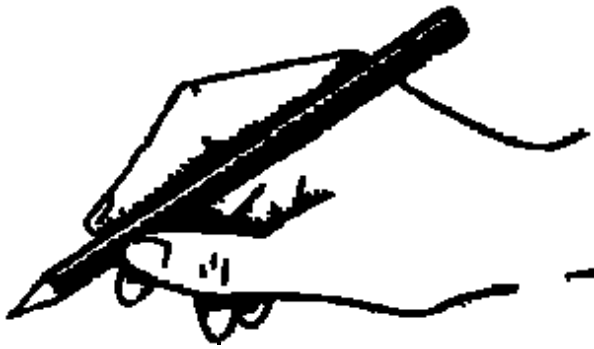

Picture C (Luttgens 1997)

<http://www.siue.edu/ELTI/Workshops/Writing/Copyofbwhandwriting.gif>

The power grip as described by Hamilton and Luttgens (1997) requires flexion of all fingers, with a stabilizer role for the thumb. Power gripping is very common among occupational workers (Wells 2001; Greig 2004), and has three sub classifications. These three include the spherical power-grip, cylindrical power-grip, and the hook power-grip (Luttgens 1997). The spherical grip is similar to the power grip, but the fingers remain spread out such as when used to shoot a basketball or to throw a baseball (Luttgens 1997).



Picture D (Luttgens 1997)

[http://cache.boston.com/bonzai-fba/Globe\\_Photo/2005/09/23/1127491824\\_6764.jpg](http://cache.boston.com/bonzai-fba/Globe_Photo/2005/09/23/1127491824_6764.jpg)



Picture E (Luttgens 1997)

[http://www.lonestarbasketball.com/training/ps\\_workshop/ball\\_hand\\_sm.jpg](http://www.lonestarbasketball.com/training/ps_workshop/ball_hand_sm.jpg)

A hook grip is a type of power grip that does not use the thumb (Luttgens 1997). The hook grip is commonly seen in hanging activities such as the Olympic rings.



Picture F (Luttgens 1997)

<http://seacoastdates.com/news/jr22.jpg>

Most occupational and recreational gripping involves the cylindrical grip. This type of power grip involves all four fingers, with the thumb together. Cylindrical power gripping can be enhanced with ulnar deviation since ulnar deviation places the 2<sup>nd</sup> and 3<sup>rd</sup> digits more in line with the pull of the finger flexor muscles (Luttgens 1997). This may not be optimal in two ways. First, it places the wrist out of a neutral posture (factor in cumulative trauma disorder), and second, increasing the potential grip maximum can lead to increased muscle activity of the ECR muscle. Examples of the cylindrical power grip include gripping a golf club, tennis racket, hammer, and gallon of milk. The designation of type of grip is also important for lateral epicondylalgia reporting in the literature.

Though TE is a condition found in both occupational and recreational settings, the eccentric nature of the tennis backhand does not translate into most occupational job tasks. A variable factor from which all reported TE cases share is the grip mechanics. This is why gripping, as a function of TE etiology, should be investigated further.

### *Muscle Activation*

Snijders et al. (1987) proposed a biomechanical model to help explain wrist extensor activity during gripping and pinching activities which concluded that the extensor mass must counter the flexor moment created by the finger flexors to maintain a neutral wrist posture. Although the wrist extensors, including the ECR, were active, Snijders and colleagues could not explain ECR irritation with this model since the ECR is one of many wrist extensors which would counter the finger flexor moment. Further research was suggested to specifically explain why the ECR is the muscle of concern for persons with TE.

Loren et al. (1996) suggested that of all the muscles which actively extend the wrist, the ECR has the greatest moment capabilities regardless of wrist position. The extensor muscles measured included the extensor carpi ulnaris, extensor carpi radialis brevis, and extensor carpi radialis longus. This 1996 study, however, did not consider the extensor digitorum (ED), which can potentially have a greater moment arm at the wrist due to its more distal insertion in relation to the ECR. When an individual grips or pinches an object such as a hammer, pliers, racket, or golf club, the wrist extensor muscles will be activated. The counter-moment model proposed by Snijders et al. (1987) does not explain why the ECR is isolated as the primary muscle of concern in 64 percent

of TE suffers (Nirschl 1979), nor why the ECR is one of the structures irritated in 91 percent of patients complaining of TE (Nirschl 1979). The role of the ECR as the muscle most commonly associated with isolated TE may be due to a selective recruitment strategy by the nervous system which compensates for one muscle's inhibition by increasing the force output of another, specifically the ECR.

### *Reciprocal Inhibition and the ECR Shift*

Isometric contractions elicit the highest amount of reciprocal inhibition, causing the corresponding antagonistic muscles to be inhibited (Rauch 1989). In gripping, the finger flexor muscles are continually, isometrically contracted, pulling the corresponding tendons around the gripped object. This constant activation exposes the antagonistic finger extensors, mainly the extensor digitorum (ED), to this extreme type of inhibition. Sustained finger flexor activity, particularly that of the Flexor Digitorum Superficialis and Profundus also induces a wrist flexion moment. This wrist flexion moment must be countered by the wrist extensors to maintain a neutral wrist posture. Since the ED is not only a finger extensor, but also a wrist extensor, inhibiting its activity would necessitate a greater contribution from the synergistic extensor muscles that also cross the wrist joint for a given grip magnitude. The ECR may be a prime candidate for this compensation, because it possesses the longest moment arm of the non-ED wrist extensors (Loren 1996). Furthermore, due to the attachment of the ECRB on the base of the third metacarpal of the hand (center of the hand), the muscle tendon is in an optimal mechanical position to provide a wrist extension counter-moment when gripping. This

compensatory action of the ECR may be a contributing factor for irritation of the lateral epicondyle in tennis elbow.

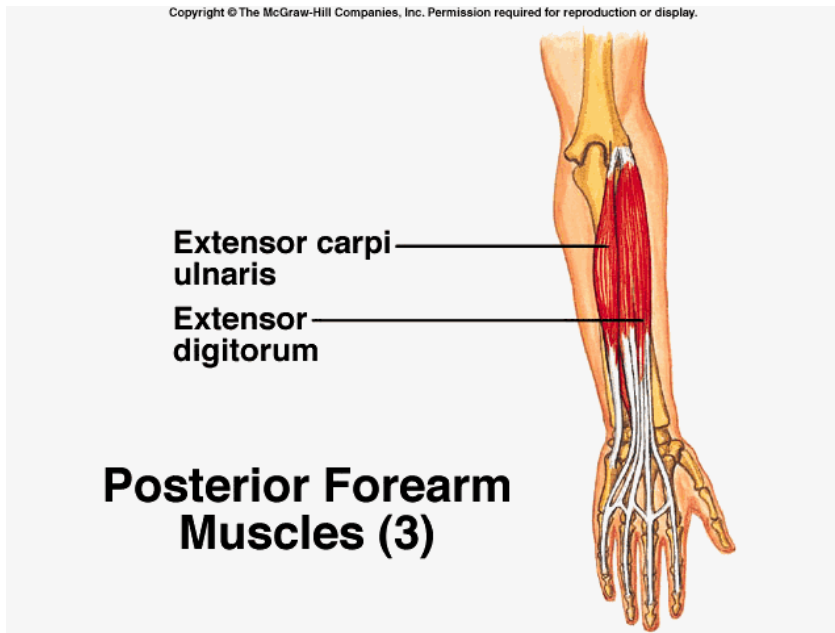

Picture F

<http://www.octc.kctcs.edu/gcaplan/anat/images/Image399.gif>



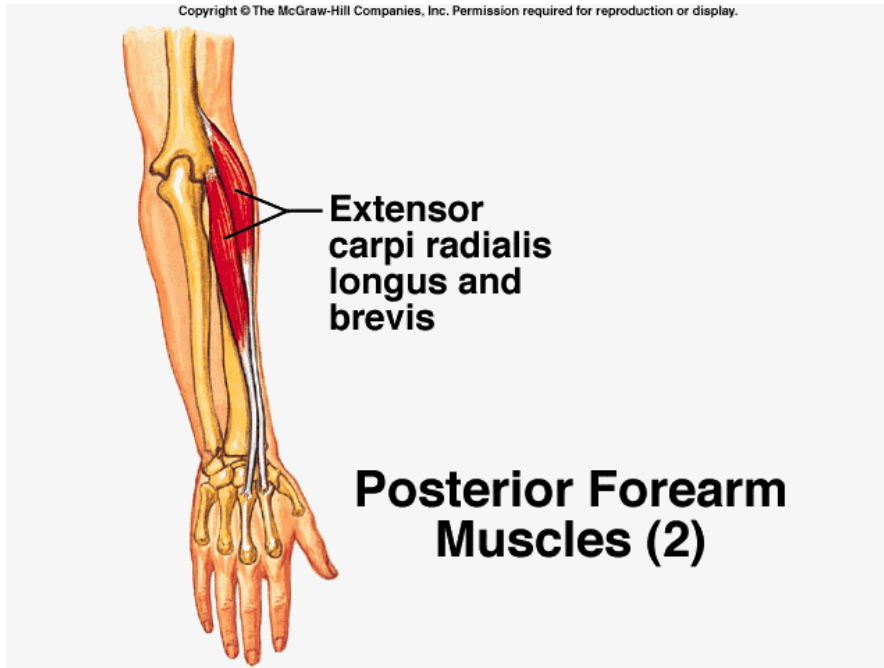

Picture G

<http://www.octc.kctcs.edu/gcaplan/anat/images/Image365.gif>

The concept of ECR compensation can be rationalized through previous research (Oda 2001). When researching fatigue in the extensor digitorum (ED) and flexor digitorum profundus (FDP) with maximal gripping, Oda (2001) demonstrated that the ED was shown to fatigue, where as the FDP did not (Oda 2001). Since the wrist neutral moment is maintained during gripping and the FDP was not fatigued, the ECR activity, in theory, would go up with ED fatigue to maintain the same wrist extension counter-moment supplied by the non-fatigued finger flexors. Campbell and Weimar (unpublished) have demonstrated this acute compensation by the ECR when ED activity is decreased. Since TE is widely considered to be a chronic overuse injury, ED fatigue (wrist extensor counter-moment muscle) with no FDP fatigue (wrist flexor moment

muscle) would support the ECR shift (increase ECR activity with decrease ED activity). The ECR shift is a term given to an increase in muscle activity compensation by the ECR in direct response to ED fatigue or inhibition associated with gripping (Campbell and Weimar unpublished) or fatigue (Oda 2001). Oda and Kida (2001) did not explain why the ED fatigued after prolonged gripping while the FDS did not. However, a very practical explanation exists based on the fact that some muscles are more or less likely to fatigue based on how we use them in activities of daily living.

### *Tonic and Phasic Muscles*

One way to classify muscles is by the tonic or phasic characteristics of the muscle. Tonic, as the name implies (tone), is a classification given to muscles which are prone to substantial activity throughout the body. These muscles tend to be recruited regularly for postural reasons. Muscle tone is related to degree in which the muscle is recruited. These muscles are far less likely to fatigue because of regular sustained intervals of activity, just to maintain upright posture and accomplish tasks of daily living. Tonic and phasic muscles are different much in the same way as fast twitch and slow twitch muscle fiber types. Twitch characteristics can be changed based on innervation patterns similarly to tonic and phasic muscles. The difference between the two is based on the characteristics examined for the muscle during its activation pattern. The muscles that erect our spine for example (erector spinae) are classic tonic muscles. They are in constantly activated beyond a resting level if we are to maintain upright posture while sitting, standing, walking, or running.

Tonic muscles tend to be biarticular muscles. Tonic muscles also tend to be flexors of the body. Finger, wrist, elbow, knee flexors are examples of this trend. In our inertial environment flexors tend to be recruited more than extensors (Neumann 1989).

The basis of tonic and phasic muscles can be summarized by the “reversibility principle”. The more a muscle is innervated, the more tone it will possess, the less resistance to fatigue it will have, and a greater propensity to tightness will be displayed. If you do not “innervate” a muscle it will possess less tone, the muscle will display a greater susceptibility to fatigue, and a greater propensity to weakness.

In the wrist, the wrist flexors display a tonic nature. The tonic wrist flexors include the flexor carpi radialis, flexor carpi ulnaris, palmaris longus, flexor digitorum superficialis, and flexor digitorum profundus. These tonic muscles are antagonists to the wrist extensor muscles. Specifically, the finger flexors are direct antagonists to the finger extensors. Not only do the wrist flexors display more tone than the finger extensors, but as a muscle group there are also more wrist flexors (5), than wrist extensors (4)(Neumann 1989).

The ECR and ED are phasic muscles, which cross the wrist joint (Neumann 1989). Because the ECR is both uniarticular and an extensor, it is a prime candidate to be classified a phasic muscle. However since the ECR is neurologically recruited during gripping, in theory, it would have the same recruitment pattern as the tonic finger flexors. This phenomenon suggests the ECR, which is designed mechanically (origin on lateral epicondyle) as a phasic muscle, but being activated tonically. However, the muscle origin may not be designed for the tonic recruitment of the muscle during long term gripping activities. The way in which the ECR may show its limitations is in the

degeneration on the tendon origin. Oda and Kida (2001) support the ED as a muscle that is prone to weakness when directly compared to the FDP, which is fatigue resistant. In their research, maximal gripping fatigued the ED muscle, while FDP did not show signs of fatigue.

### *Active and Passive Insufficiency*

Active insufficiency is defined as the inability of a multi-joint muscle to shorten at both ends simultaneously. This inability is due to the physiological limitation of the active components of the muscle to be able to maintain an optimal force production length while shortening (Kreighbaum 1981; Thompson 2004). The hamstrings illustrate this phenomenon. Consider the hamstrings, which cross both the hip and knee joints, acting to extend the hip and flex the knee at the same time. This combined shortening would decrease muscle tension due to the rapid shortening of the muscle past resting length, thus reducing the ability of the muscle to produce force, since resting length of a sarcomere is optimal for force production (Kreighbaum 1981; Thompson 2004). Passive insufficiency also creates a situation where the muscle is unable to obtain optimal force production. However, instead of shortening of the muscle, lengthening is the limiting factor. The rectus femoris muscle would be passively insufficient if the hips were extended and knees were flexed, at the same time. As the diagram below shows, active and passive insufficiency are directly related to the length tension curve of a sarcomere. The decrease in muscle tension, due to the extent of overlap of actin and myosin, is considered active insufficiency (highlighted in blue). The decrease in total muscle tension due to the increase in muscle length is termed passive insufficiency.

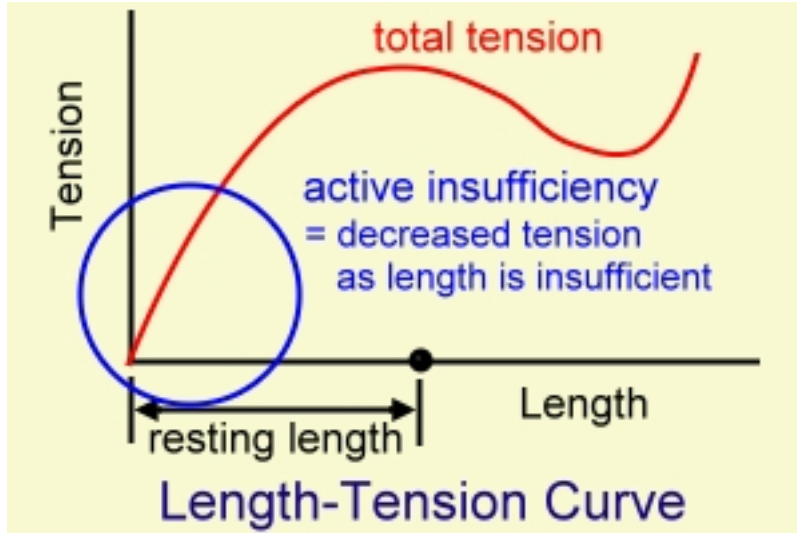

Picture H

<http://www.pt.ntu.edu.tw/hmchai/Kines04/KINmotion/Musculature.files/ActiveInsufficiencyCurve.jpg>

### *Mechanical Insufficiency*

Active and passive insufficiency describes a muscle's inability to shorten optimally at two joints simultaneously with physiological factors as the mechanism. The same concept then can be applied mechanically instead of physiologically. The same rationale of a multi joint muscle's inability to produce optimal shortening tension on two joints at the same time can be viewed through mechanical principles. This leads to the term mechanical insufficiency. Mechanical insufficiency occurs when a multi-articular muscle does not have the ability to apply optimal force at more than one joint simultaneously. Mechanical insufficiency is when a muscle, which crosses two separate joints, does not allowed efficient multi-joint movement simultaneously. A muscle is sufficient when one end of the muscle shortens and the other lengthens simultaneously, or

one end is stabilized/neutralized so that the other segment can be moved more efficiently. Mechanical sufficiency occurs when mechanical adaptations are made to ensure that a multi-articular muscle is allowed to work effectively. For example, consider a muscle that crosses a segment at both the proximal and distal ends of the muscle (crosses a segment at origin and insertion). In this condition, the joints can work to maintain the length of the muscle by shortening at one end, while lengthening at the opposite end. If both ends were allowed to move freely when a multi-articular muscle contracts, joints would not be moved efficiently (the efficiency of this muscle to contribute to joint motions will be diminished). The lengthened/stabilized end allows mechanical opposition against which the shortening end can perform its joint action efficiently. Lengthening is even more efficient than stabilizing for creating an optimal range of motion of the other articulating joint. This phenomenon of multi-articular muscles is found throughout the body. When a lifter rises from a squat, the hamstrings, for example, shorten at the hip, but lengthen at the knee. The lengthening at the knee allows for a more efficient shortening at the hips due to mechanical sufficiency of the multi-articular hamstring during the closed kinetic chain squat. When one end of a multi-articular muscle is not stabilized, the efficiency of the shortening decreases. This is called mechanical insufficiency when the insufficient shortening of one end of a multi-articular muscle is caused by the lack of stabilization of the other end. Mechanical sufficiency explains how the finger flexors can create a sufficient wrist flexion moment. By eliminating finger flexion movement at the end of the range of motion of the grip, the wrist flexion moment is able to occur more efficiently. The continual shortening of the fingers eventually will lead to a wrist flexion moment when the fingers are fixed around a

gripped object. Another way to consider this concept is if the handle lay in the palm of the hand and the fingers are fully extended. As the fingers begin to actively flex (move in flexion) optimal wrist flexion is not achieved. When the fingers stop actively flexing (wrap around the handle), mechanical insufficiency is eliminated, and transfer to a wrist flexion moment can occur optimally by the flexors digitorum profundus and superficialis.

Mechanical sufficiency can be created by other muscles/segments in two ways. The first mechanism is by moving the joints which a multi-articular muscle crosses in opposite directions. This means that a multi-articular muscle such as the hamstrings concentrically flexes the knee and extends the hip; concentric hip extension (shortening proximal end) occurs optimally by the hamstrings if the knee is synchronously extending (lengthening distal end). The second mechanism for achieving mechanical sufficiency is through the stabilization of one joint, while the other is allowed to move. In the case of the hamstrings, if the hip is stabilized either by internal co-contraction of an external hip flexion counter-moment, the hamstrings will be more sufficient as knee flexors due to the stabilizing of the other end. In observing human movement multi-articular muscles tend to shorten at one end and lengthen at the other for 2 reasons (one physiologically and one mechanically). 1. It maintains a better length-tension relationship that is favorable for force production (decreased active insufficiency) 2. It raises the level of mechanical sufficiency by lengthening one joint, of a multi-articular muscle, so that the shortening end can have greater force production. Mechanical sufficiency creates a uni-articular muscle by eliminating the motion of one or more ends of a multi-articular muscle. Another example of this would be the gastrocnemius during jumping. The gastrocnemius is a concentric knee joint flexor as well as a concentric ankle joint plantar flexor. When

jumping, the concentric knee extension allows the gastrocnemius greater mechanical advantage as a plantarflexor. The more mechanical insufficiency is eliminated, such as by stabilizing or lengthening a segment, the more uni-articular in nature we can make the muscle as it is applied to the muscle shortening end.

The concept of mechanical insufficiency applies to the isometric grip. The fingers are not moving (flexing) when they are wrapped around a gripped object. When the finger movement (flexion) is eliminated, the neutralization of the finger movement allows the finger flexor muscles to sufficiently pass its moment/activity to the wrist joint, thus creating a wrist flexion moment that must be countered if a neutral wrist posture is to be maintained.

### *Neurological Insufficiency*

Mechanical insufficiency describes a muscle's inability to shorten optimally at two joints simultaneously with mechanical factors as the mechanism. A similar concept also can be applied through neural mechanisms instead of mechanical. Neurological insufficiency is when a multi-articular muscle must lessen its activity neurologically to disallow one of the articulating joint motions to occur. For example: The biceps brachii decreases activity during elbow flexion when the radio-ulnar joint is pronated and/or semi-pronated. If the biceps were to be activated fully, a greater supination moment would be induced challenging the pronated position. Neurological insufficiency is minimized by antagonistic neutralizer muscle activity, which is the limiting factor on how great the nerve can recruit the multi-articular muscle. For example, the activity of the biceps in this example is limited to the amount of neutralizer muscle activity, which



balance the supinator moment. Since the biceps is limited by the amount of neutralizer moment, this limitation is inherently insufficient. In the wrist/hand, the radial nerve innervates the ED. Through this nerve, the brain is neurologically limiting ED recruitment as a wrist counter-moment. If this were not the case, the ED would be called upon to shorten which would cause the fingers to extend. The potential for the fingers to extend does not allow for optimal transfer to the wrist extension counter-moment by the ED. Physiologically, the finger flexors would inhibit the ED muscle when gripping, but mechanically neurological insufficiency would also limit the recruitment of the ED to maintain grip.

### *Grippers Elbow*

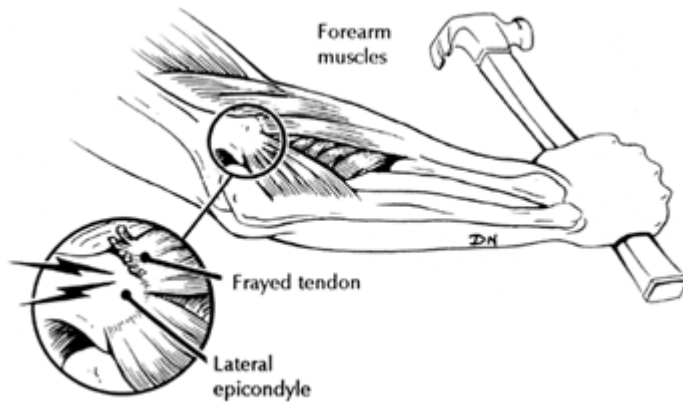

Picture I

<http://www.tennis-elbow.net/images/hammerelbow.gif>

As previously mentioned, the term lateral epicondylitis is gradually being replaced with a more suitable term of lateral epicondylagia, with the latter being more

appropriate due to lack of inflammation found in this condition. Campbell and Weimar (unpublished) suggest a similar shift from the term tennis elbow to the new term “gripper’s elbow (GE)”. Since tennis accounts for only 5-10 percent of reported cases, assigning such a specific term is misleading. It is more appropriate terminology for an occupational worker to have gripper’s elbow than tennis elbow. Tennis elbow etiology refers to eccentric loading of the racket. The new term gripper’s elbow would lend credence to the importance of the grip in the etiology of tennis elbow research.

The theory that constant ECR activity during gripping degenerates the tendon of the muscle origin leads to useful ways to assist persons with this pathology, and to potentially prevent this ailment in the future for athletes/workers. Since the ECR is acting as an internal counter-moment to keep the wrist in a neutral position, could an external counter-moment force which mimics wrist extension lessen the ECR activity during maximal gripping? Further, if a maximal external counter-moment force is shown to significantly lessen ECR activity with gripping, would various sub-maximal external wrist extensor counter-moment forces likewise significantly lessen the ECR response to gripping? Last, would an external counter-moment force brace, at various sub-maximal wrist extension counter-moment force magnitudes, decrease the ECR response to maximal gripping? Creating a constant external counter-moment brace for individuals with GE would be very helpful to sport/occupational workers. Specifically, it could be used to decrease the perceived pain of symptomatic people.

*Previous Research on Counter-moment Forces:*

Recent studies have demonstrated the external wrist extension counter-moment mechanism and its effect on the muscle activity of the wrist extensors (Van Elk 2004; Faes 2006). Van Elk et al. (2004) demonstrated that a wrist extension force of 1%, 2%, and 3%, of MVC significantly decreases wrist extensor muscles during gripping at intensities of 10%, 20%, and 30% of grip MVC. The researchers used grip strength as a means of %MVC for the counter force as well as the standardized sub maximal grip force. The participants were placed in a seated position and grip force was measured using standard grip dynamometry while wrist extension force was applied via free weight balanced on a plate. The plate produced its wrist extension moment via a connecting cable from the free weights to the wrist through a pulley. The results of this study suggests that the greater the extension force applied to the palm, the lesser activity of the wrist extensors when gripping at 10%, 20%, and 30% MVC. The researchers followed up this study with a more applicable research question, which looked at how do the counter moment force effect persons symptomatic with lateral epicondylagia. Faes et al. (2006) utilized a plaster shell as a wrist extension counter moment force application and formed it to each participant's palmer surface. This splint crossed the wrist joint and provided a wrist extension moment by pushing into the palmer surface of the symptomatic hand. Wearing this splint continuously for 3 months was shown to significantly increase pain free grip in persons symptomatic with lateral epicondylagia (Faes 2006). The conclusions of Van Elk et al. (2004) and Faes et al. (2006) are limited. The ECRB and ECRL muscles are in too close proximity to be accessible via surface electromyography as previously discussed. Van Elk et al. (2004) and Faes et al. (2006)

however, both reported muscle activity for the individual muscles (ECRB and ECRL) with the technique of surface electromyography. Other limitations include grip magnitudes of 10%, 20% and 30% that were used to simulate activities of daily living. In work and sport related activities however, persons may utilize a maximal grip or a grip greater than 30% of MVC to accomplish a desired task. This leads to the question of whether the wrist extensors follow the same pattern at grip intensities greater than 30%, when various wrist extension forces are applied externally.

Another major limitation in the methods of Van elk et al. (2004) is with the external wrist extension counter-force device. The external wrist moment was applied to the palm of the hand “pushing” the wrist into extension. This plastic molding shell was heated in warm water and molded into the palm of the hand, then cooled to form a hardened shell. The added bulk to the palm of the hand may have influenced the gripping mechanics of the participants in two ways. The first way in which grip may have been altered is with the direct bulk of the splint altering gripping mechanics. Factors such as decreased kinesthesia and sensory feedback from the palm may have led to alterations in the gripping intensity. More importantly, the added bulk of the pad would place the metacarpal-phalangeal joints of fingers 2-5 in a more extended position. Unpublished data by Campbell and Weimar suggest that wrist extensor muscle activity is greater when the fingers are in less flexion. The added bulk would allow more MCP extension thus decreasing the ECR activity via the ECR shift.

The same researchers from the Netherlands, Faes and Van Elk, followed up with two main experiments utilizing symptomatic persons with lateral epicondylagia. Faes et al (2006) applied the wrist extension device to symptomatic persons for a period of three

months. They measured pain free grip strength as the major outcome measure. The brace was shown to significantly lower perceived pain during grip after the 3-month trial. The same limitation is present in this study as in the previous. The application of a wrist extension device to the palm of the hand may affect grip dynamics. By altering the grip of objects via the palmer shell, the participants may be gripping with less muscle force, and thus not activating the wrist extensors as a counter-moment to the same degree as a full range of metacarpal-phalangeal flexion. Work done with metacarpal-phalangeal range of motion and gripping showed that the more flexion occurs and the MP joint, the more ECR shift that is seen and thus the more activity of the wrist extensors as a counter-moment. Creating an environment where the wrist extension force can work externally while not changing gripping dynamics in the palm or range of motion in the fingers would further support these previous findings by van Elk (2004) and Faes (2006).

## CHAPTER III. METHODS

The purpose of this study was to investigate the influence of external wrist counter-moment forces on gripping and muscle activity of symptomatic and non-symptomatic persons. There are three proposed components to this project: (1) Maximum Counter Moment Force, (2) Task Counter Moment Force, and (3) Symptomatic Counter Moment Force. This chapter will present each component and will discuss: (1) participants, (2) equipment, (3) electrode set up, (4) procedure, and (5) statistical analysis. The Auburn University Institutional Review for Research Involving Human Subjects has approved each research protocol.

### Participants

#### *Max Counter-Moment Force*

Twenty participants, (10 male, 10 female), who are TE asymptomatic between the age of 19 and 40 served as volunteer participants in this study. All participants were informed of the experimental procedure before being given an informed consent approved by the Auburn University Office of Human Subjects Institutional Review Board (IRB) protocol. In addition to the informed consent, participants met the inclusion criteria, which was a medical questionnaire (see appendix C). Exclusion from participation in the study included (a) history of tennis elbow, (b) injury to elbow in last

year, (c) injury to hand in last year, (d) injury to wrist in last year, (e) surgery to dominant arm, (f) voluntary subject withdrawal, (g) and/or drug use.

#### *Task Counter-Moment Force*

Twenty participants, (10 male, 10 female), who are TE asymptomatic between the ages of 19 and 40 will serve as volunteer participants in this study. All participants were be informed of the procedure of the experiment before being given an informed consent approved by the Auburn University Office of Human Subjects Institutional Review Board (IRB) protocol. In addition to the informed consent, participants answered the Exclusion Medical Questionnaire. Exclusion from participation in the study included (a) history of tennis elbow, (b) injury to elbow in last year, (c) injury to hand in last year, (d) injury to wrist in last year, (e) surgery to testing arm, (f) voluntary subject withdrawal, (g) and/or drug use.

#### *Symptom Counter-Moment Force*

Eight participants, (4 male, 4 female), who are TE symptomatic over the age of 19 will serve as volunteer participants in this study. All participants were informed of the procedure of the experiment before being given an informed consent approved by the Auburn University Office of Human Subjects Institutional Review Board (IRB) protocol. In addition to the informed consent, participants answered the Inclusion Medical Questionnaire. Inclusion into participation in the study include (a) perceived pain on the lateral side of the elbow, (b) point tenderness at the elbow over the extensor origin, (c) perceived pain at the lateral epicondyle during resisted wrist extension, (d) no history of

surgery on the affected elbow, (e) no history of neural disorder such as carpal tunnel syndrome (Verhaar 1993).

## Equipment

### *Force Platform*

Maximal wrist extension counter-moment force was measured via the AMTI™ OR6-7-1000 Biomechanics Sport Platform®. The force plate, which utilizes four force transducers, recorded the reaction force in Newtons at a sampling rate of 100 Hz. The force platform will record the maximal wrist extension counter-force for each trial (See figure 2).

### *Electromyography*

Muscle activity of the ECR (Extensor Carpi Radialis Longus and Brevis) muscle will be measured using a Noraxon® Myosystem 1200™ electromyography (EMG) system (See figure 3). The ECR is composed of two separate muscles, however surface EMG cannot differentiate between the electrical activities of the two. This limitation is why the muscle will be referenced as the ECR (longus and brevis). Surface electrodes were placed distal to the ECR motor unit to measure muscle activity. The dependant measure, milli-volts (mV), measured of the electrical activity of the specific muscle. Since the same muscle (EMG mV) was compared in the same testing session, no standardization (% maximum) was needed for sub-maximal trials.



### *Counter Moment Force Device*

Constant supportive wrist extension counter-moment force was supplied by the Marcy® Wedge™. This device has previously been used in tennis elbow rehabilitation research (Smith 1993). The Wedge™ is designed as a wrist flexion exercise device for both right and left hands. The user placed his/her hand inside the wedge and grips the handle (See figure 4). In a relaxed position, the user's wrist was in an extended position while gripping the handle. To maintain neutral wrist position while in the Wedge™ required an isometric muscle action of the wrist flexors. This isometric muscle action resisted the wrist extension moment created by the Wedge™. The resistance of the Wedge™ was adjustable from level 1 to 5. The resistance was maintained at level 1 for all trials requiring a wrist extension counter-moment force.

### *Force transducers*

Grip magnitude was measured using the Economical Load & Force System (ELF®) by Flexiforce™. The ELF® system allows the recording force transducer to be conveniently placed on various objects to measure gripping magnitude (See Figure 5). The ELF® force sensor was calibrated with a standard 10 pound force placed on the recording sensor. This calibration allows the sensor to standardize to a known weight. The recording sensor was housed within a flexible strip, which is designed to conveniently wrap around gripping handles. All gripping trials had the ELF® recording sensor placed directly between the item being gripped and the 3<sup>rd</sup> distal phalange. The chosen location had two benefits. It was easier to confirm correct finger placement of the

sensor. The second benefit was less dampening from the bony digit in contact with the gripping item surface versus the gripping item surface in contact with the fleshy palm of the hand.

### *Borg Scale*

Perceived discomfort for data collection involving participants symptomatic with tennis elbow was measured with a modified Borg Scale for perceived discomfort (See figure 6). The traditional Borg Scale is based on a 6 to 20 scale, and is a subjective way for an individual to quantify his/her exertion level. This modified scale was designed to quantify perceived discomfort in place of exertion. As with the traditional exertion scale, the higher the number a participant reports, the greater the discomfort perceived. The Borg scale value was a dependant measure for data analysis. The modified 10 point Borg scale has been used for perceived discomfort and pain in previous studies (Ulin 1993; Knight 2004).

### Electrode Placement

Electromyography (EMG) electrode sites was be prepared by following the standard protocol set forth by the Selected Topics in Surface Electromyography for Use in the Occupational Settings: Expert Perspectives (Soderberg 1992). This process included: (1) shaving any hair from the area, (2) abrading the skin, and (3) cleaning the site with isopropyl alcohol (Soderberg 1992). Following skin preparation, motor units were located on subjects using an EMS-1C™ portable stimulator unit by Med Labs® (Interrupted D.C. current: 0-18 milliamps peak, 30-millisecond, duration 1 pulse per

second) (See Figure 7). When a chosen motor unit was located, EMG surface electrodes were placed distal to the motor unit in the area of most muscle bulk. Proper electrode placement was confirmed through EMG with manual muscle testing. Subjects were asked to flex and extend their fingers to confirm no extensor digitorum (ED) cross talk. Participants were then asked to actively extend the wrist to confirm extensor carpi radialis (ECR) electrode placement. Testing began after muscle confirmation is complete.

## Procedures

### *Max Counter-Moment Force*

Following procedure explanation, subjects were asked to complete the medical questionnaire and sign the Institutional Review Board's Human Subjects approved informed consent form, allowing the testing procedure to continue. After EMG electrode set up, participants were then be asked to sit with their elbow flexed at 90 degrees and shoulder abducted to 90 degrees, fingers fully flexed around a tennis racket handle, and radio-ulnar joint in pronation (the tennis racket handle will be placed between the participant's thenar and hypothenar eminence in the tested hand). A height adjustable static wrist counter-force support was placed under the hand (connecting the hand to the force platform) so that the 2nd - 5th proximal phalanges were touching the support longitudinally along the bones. No deformation or fatigue was reported with the device when placing a known weight (25 pounds) on the device measuring the ground reaction force over 50 trials. Participants were then simultaneously maximally grip the tennis racket as well as push against the static counter-force device maximally for two seconds (See Figure 2). Wrist and shoulder position were monitored through visual inspection.

Kida and Oda (2001) used two seconds for maximal gripping trials based on similar techniques. These two maximal voluntary contractions (grip and counter-force) (MVC's) served not only as EMG MVC (ECR) but also wrist counter-force MVC (force plate) magnitude. A five-minute rest followed this trial (Kida 2001). Participants repeated the above procedures at 25, 50, and 75 percent of MVC force plate data while simultaneously gripping the tennis racket handle to the previous MVC magnitude. A minimum of three minutes rest between sub-maximal trials was employed. One trial of each sub-maximal force will be performed. Following completion of the isometric trials, EMG electrodes were removed and participant's skin will be evaluated for potential allergic reactions before leaving the lab.

#### *Task Counter-Moment Force*

Following procedure explanation, subjects were asked to complete the medical questionnaire and sign the Institutional Review Board's Human Subjects approved informed consent form allowing the testing procedure to continue. Following electrode preparation participants were asked to perform the following 3 tasks in random order:

1. Tennis Racket Handle

##### *Baseline*

Participants were asked to grip a tennis racket handle with the following directions, "grip as hard as you feel necessary". Fingers were fully flexed around a tennis racket (the tennis racket handle was placed between the participant's thenar and hypothenar eminence in the tested hand). EMG data was collected as an outcome measure, and force grip data will be collected as a reference for trial.

### *With assistance*

Participants were asked to place their hand in the Wedge™ wrist curl device and grip a tennis racket handle with the same force as achieved in the baseline condition. The matching force was achieved using the ELF® system to measure the trial without assistance. This magnitude was then matched for the “with assistance” trial. In addition to the fingers being fully flexed around a tennis racket (the tennis racket handle was placed between the participant’s thenar and hypothenar eminence in the tested hand), the participants were asked to achieve and maintain a neutral wrist posture. EMG data was collected as an outcome measure.

## 2. Hammer

### *Baseline*

Participants were asked to grip a hammer in a power grip position with the following directions, “Grip as hard as you feel necessary”. Fingers were fully flexed around the hammer in the same manner as indicated in the task 1 procedure. EMG data was collected as an outcome measure, and force grip data will be collected as a reference for the “With Assistance” trial.

### *With Assistance*

Participants were asked to place their hand in the Wedge™ wrist curl device and grip a hammer (in a power grip position) with the same force as achieved in the hammer baseline trial. In addition to the fingers being fully flexed around the hammer (the handle of the hammer was placed between the participant’s thenar and hypothenar eminence in

the tested hand), the participants will be asked to achieve and maintain a neutral wrist posture. EMG data was collected as an outcome measure.

### 3. Gallon of Fluid

#### *Baseline*

Participants were then asked to power grip a gallon of water with the following directions, "Grip as hard as you feel necessary to lift the water". Fingers were fully flexed around the jug in the same manner as in trial 1. EMG data will be collected as an outcome measure, and force grip data will be collected as a reference for condition 4.

#### *With Assistance*

Participants were asked to place their hand in the Wedge™ wrist curl device and grip a gallon of water (in a power grip position) with the same force as achieved in the gallon of water baseline trial. In addition to the fingers were fully flexed around the gallon of water (the handle of the water was placed between the participant's thenar and hypothenar eminence in the tested hand), the participants were asked to achieve and maintain a neutral wrist posture. EMG data was collected as an outcome measure.

Following completion of the six trials, EMG electrodes were removed and participant's skin will be evaluated for potential allergic reactions before leaving the lab.

#### *Symptom Counter-Moment Force*

Participants identified as symptomatic were prepared for EMG placement following the standard EMG electrode set up indicated above. Participants were then complete the following trials in random order:

*Condition A.*

Participants were instructed to maximally grip the Wedge™ wrist curl device handle alone with no counter-moment force being applied. Upon completion of this trial, participants were then grade their perceived discomfort on a scale of 1-10 (See Figure 6). Grip force, EMG, and perceived discomfort scale will serve as outcome measures.

*Condition B.*

Participants were instructed to maximally grip the Wedge™ wrist curl device handle while the device supplies an external wrist extension counter-moment force. Upon completion of this trial, participants were then grade their perceived pain on scale of 1-10 (See figure 6). Grip force, EMG, and perceived discomfort scale served as outcome measures.

A minimum of three minutes of rest were provided to the participants in between each trial (Oda 2001). Following completion of the isometric trials, EMG electrodes were removed and participant's skin was evaluated for potential allergic reactions before leaving the lab.

## Statistical Analysis

### *Max Counter-Moment Force*

A one-way repeated measures ANOVA model, with five levels of the repeated measures factor was used to determine the effect of external wrist extension counter moment on ECR EMG amplitude. This design yielded a main effect for the repeated factor of counter-moment intensity. An alpha level of .05 was used to determine statistical significance.

### *Task Counter-Moment Force*

Three dependant samples *T*-test, one for each gripping object, was used to determine the effect of an external wrist extension counter-moment force on ECR EMG amplitude. This design yielded a main effect for each task counter-moment. An alpha level of .05 was used to determine statistical significance.

### *Symptomatic Counter-Moment Force*

Two dependant samples *T*-test was used to determine the effect of an external wrist extension counter-moment force on ECR EMG amplitude, and perceived pain scale. This design yielded a main effect for each measure. An alpha level of .05 was used to determine statistical significance.





*Figure 1.* Anatomical Insertion of the ECR into the Base of the 3<sup>rd</sup> Metacarpal

<http://www.rad.washington.edu/atlas/extcarpiradbrevi.html>

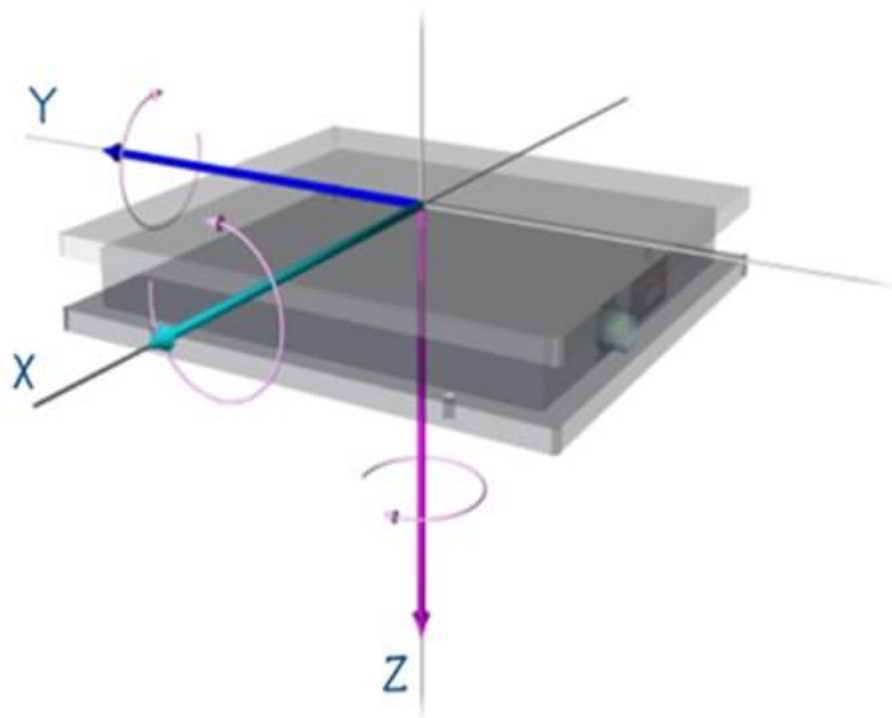

Figure 2. AMTI™ OR6-7-1000 Biomechanics Sport Platform®



*Figure 3.* Noraxon EMG System



*Figure 4. Marcy Wedge*

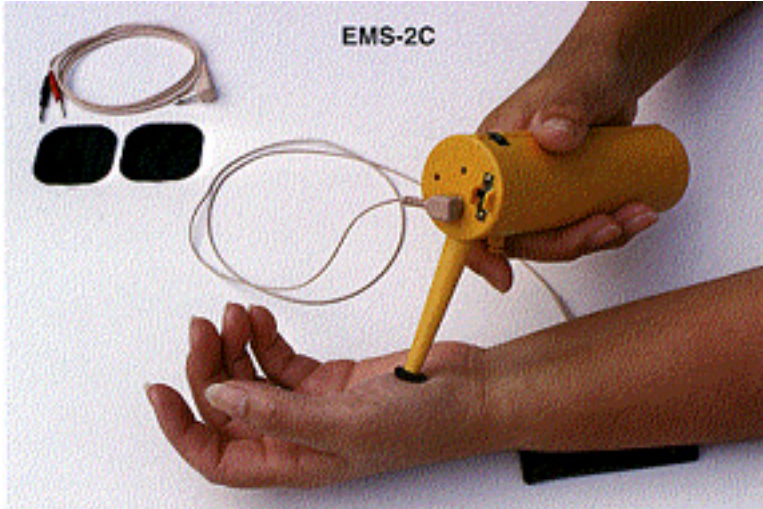

*Figure 5. ELF<sup>®</sup> System*

## Modified Borg Scale of Perceived Discomfort (RPD) Scale

- 1 No Discomfort at all
- 2 Extremely Light Discomfort
- 3 Very Light Discomfort
- 4 Light Discomfort
- 5 Somewhat Discomfort
- 6 Somewhat Heavy Discomfort
- 7 Heavy Discomfort
- 8 Very Heavy Discomfort
- 9 Extremely Heavy Discomfort
- 10 Maximal Discomfort

*Figure 6. Modified Borg Scale*



*Figure 7.* EMS-1C™ portable stimulator unit by Med Labs®

<http://hometown.aol.com/medlabsinc/ems.jpg>

## CHAPTER IV. RESULTS

The purpose of this study was to investigate the influence of external wrist counter-moments on gripping and muscle activity of symptomatic and non-symptomatic persons. There were three components to this project: (1) Maximum Counter-Moment, (2) Task Counter-Moment, and (3) Symptomatic Counter-Moment. This chapter presents the results of this project. The results are divided individual sections addressing statistical analysis for the three project components. All data was used due to no participant dropouts or persons being removed for failure to follow protocol.

### *Max Counter-Moment Force*

Mean EMG amplitude (mV) was analyzed using a one-way repeated measures ANOVA model, with five levels of the repeated measures factor. Condition one involved max grip with no counter-moment, while subsequent four trials involved maximal grip combined with maximal and sub-maximal counter-moment force; Max Grip (25% counter-moment), Max Grip (50% counter-moment), Max Grip (75% counter-moment), and Max Grip (100% counter-moment).

Data analysis revealed a significant difference between the 5 conditions. The results of which are shown in table 1. Post hoc analysis revealed a significant difference between max grip with no counter-moment and all counter-moment force trials. Posthoc



analysis also found no significant difference between counter-moment conditions. The relationship between the 5 conditions is illustrated in figure 8. Follow up was warranted utilizing ten individual paired sampled *T*-tests (one for each possible combination), which was used to show individual relationships of each condition. The results of these individual t-tests are shown in Table 2. The individual measure relationships along with significances are illustrated in figure 9-18. Max grip (no counter-moment) was significantly different than all counter-moment conditions, while there was no significant difference between any of the counter-moment conditions.

#### *Task Counter-Moment Force*

Percent Max EMG amplitude (mV) was analyzed using one way repeated measures ANOVA for three tasks. The three individual implements (conditions) included Tennis (pre-post), Hammer (pre-post), and Fluid (pre-post). The means, standard deviations, (pre and post) for each 1 way repeated measures ANOVA analysis are reported in Table 3. The *F* ratios and statistical significance for each 1 way repeated measures ANOVA analysis is reported in Table 4.

Statistical analysis revealed a significant difference % EMG max amplitude (mV) for the Tennis condition. The counter-moment force elicited a significantly lower % EMG max compared to the non counter-moment force condition. This relationship is demonstrated in figure 19, and shows the significant decrease of % EMG within the pre-post hammer condition.

Statistical analysis also revealed a similar significant difference for the hammer condition. The use of the counter-moment force treatment in the post hammer condition

measured a significantly lower % EMG max than the hammer pre condition. The significant relationship between hammer pre and post conditions is illustrated in figure 20. Data analysis revealed a significant difference for the pre-post fluid conditions. The significant relationship between the fluid pre and post conditions is shown in Figure 21.

### *Symptomatic Counter-Moment Force*

Perceived pain (1-10), mean EMG amplitude (mV), and mean grip force magnitude (lbs) was analyzed using 3 separate dependant samples *t*-test for each measure. The three individual measures included perceived pain before and after counter-moment force application (pre-post), mean EMG amplitude of the ECR muscle with and without the presence of the counter-moment force application, and mean grip force intensity with and without the presence of the counter-moment force application. The means and standard deviations, for each dependant samples *t*-test analysis are reported in Table 5. The *t* scores and statistical significance for each dependant samples *t*-test analysis is reported in Table 6-8.

Statistical analysis revealed a significant difference in perceived pain between the counter-moment force and no counter-moment force conditions for symptomatic people. Maximal gripping combined with a counter-moment force elicited a significantly lower pain scale rating compared to maximal gripping alone. This relationship is demonstrated in Figure 22, and shows the significant decrease of perceived pain scale rating with maximum grip with and without the counter-moment force. Statistical analysis also revealed a significant difference in mean EMG amplitude (mV) between the symptomatic counter-moment force conditions. Maximal gripping when combined with a

counter-moment force elicited significantly lower mean EMG amplitude when compared to maximally gripping alone (no counter-moment force condition). This relationship is demonstrated in Figure 23, which demonstrates shows the significant decrease of mean EMG amplitude (mV) between maximum grip of handle (no counter-moment force) and maximum grip of handle (counter-moment force).

Statistical analysis further revealed a significant difference in mean grip force (lbs) for the symptomatic counter-moment force conditions. Maximal gripping when combined with a counter-moment force elicited significantly lower mean grip force when compared to maximally griping alone (no counter-moment force condition). This relationship is demonstrated in Figure 24, and shows the significant decrease of mean grip force with maximum grip (no counter-moment force) and maximum grip of handle (counter-moment force).

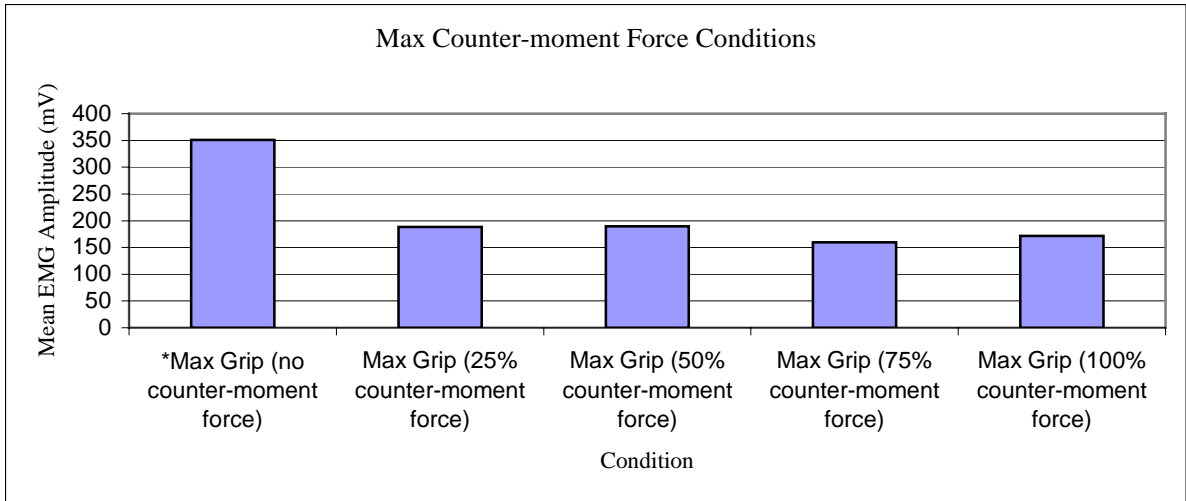

Figure 8: Max counter moment task. While the max grip condition produced significantly greater ECR EMG amplitude compared to each of the counter-moment conditions, no significant differences existed between counter-moment conditions.

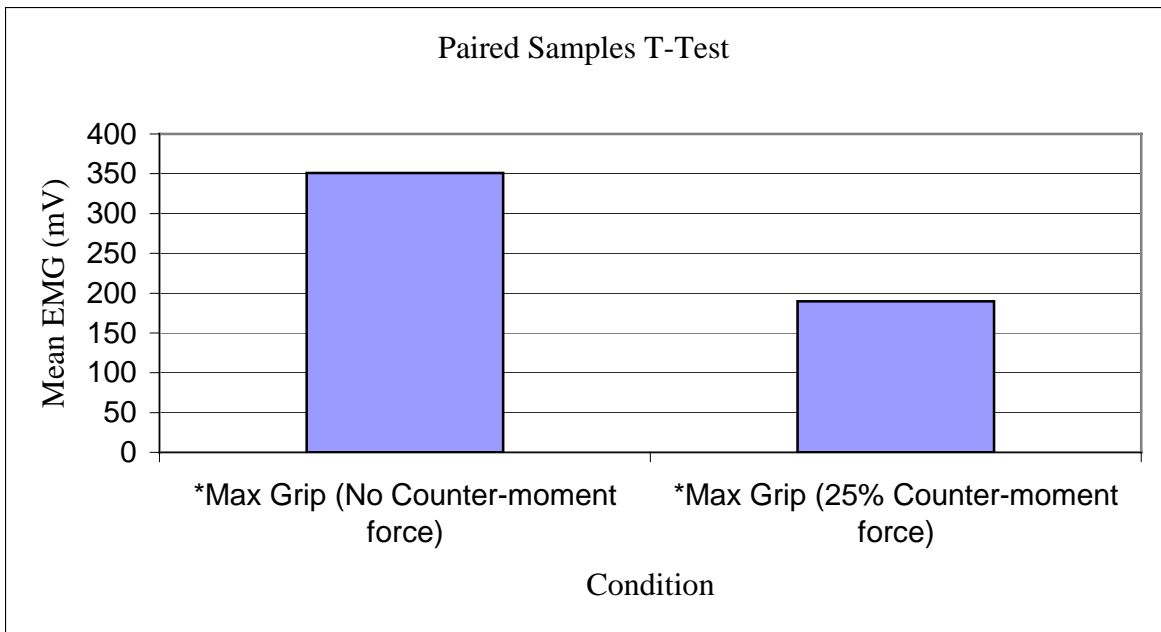

Figure 9: Maximum grip of handle without counter-moment force and with 25% maximal counter-moment force. Asterisk indicates significant difference between Max Grip (no counter-moment force) and Max Grip (25% counter-moment force).

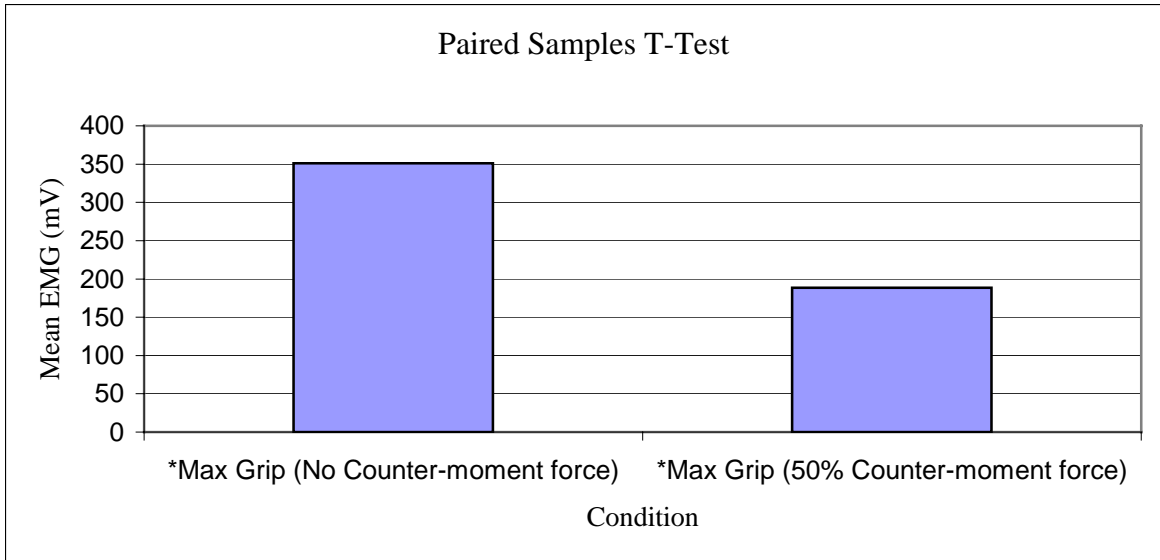

Figure 10: Maximum grip of handle without counter-moment force and with 50% maximal counter-moment force. Asterisk indicates significant difference between Max Grip (no counter-moment force) and Max Grip (50% counter-moment force).

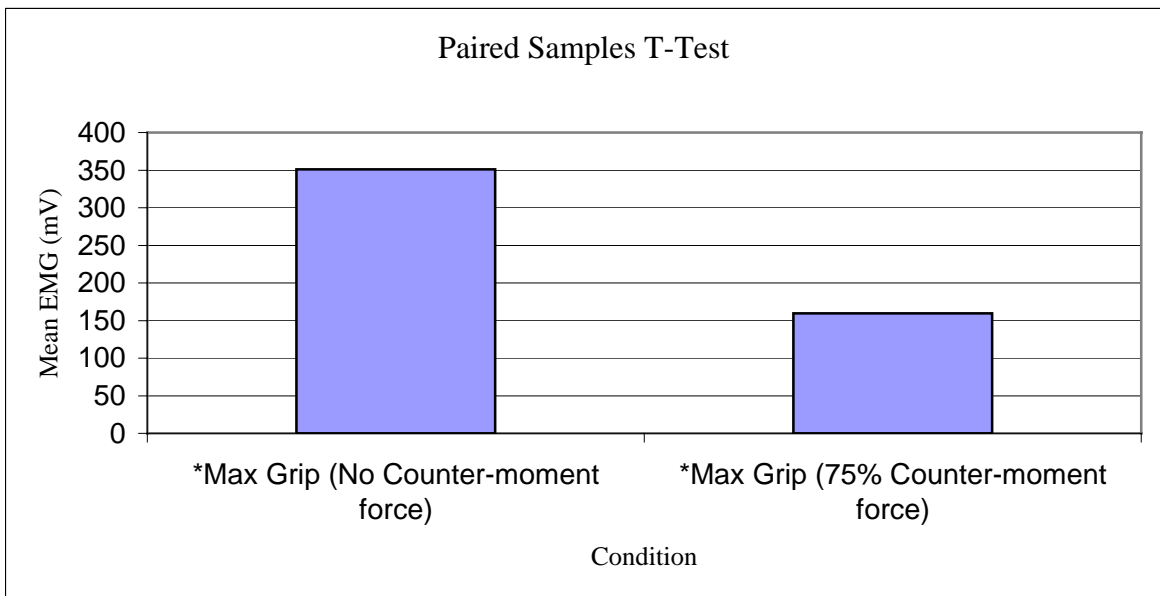

Figure 11: Maximum grip of handle without counter-moment force and with 75% maximal counter-moment force. Asterisk indicates significant difference between Max Grip (no counter-moment force) and Max Grip (75% counter-moment force).

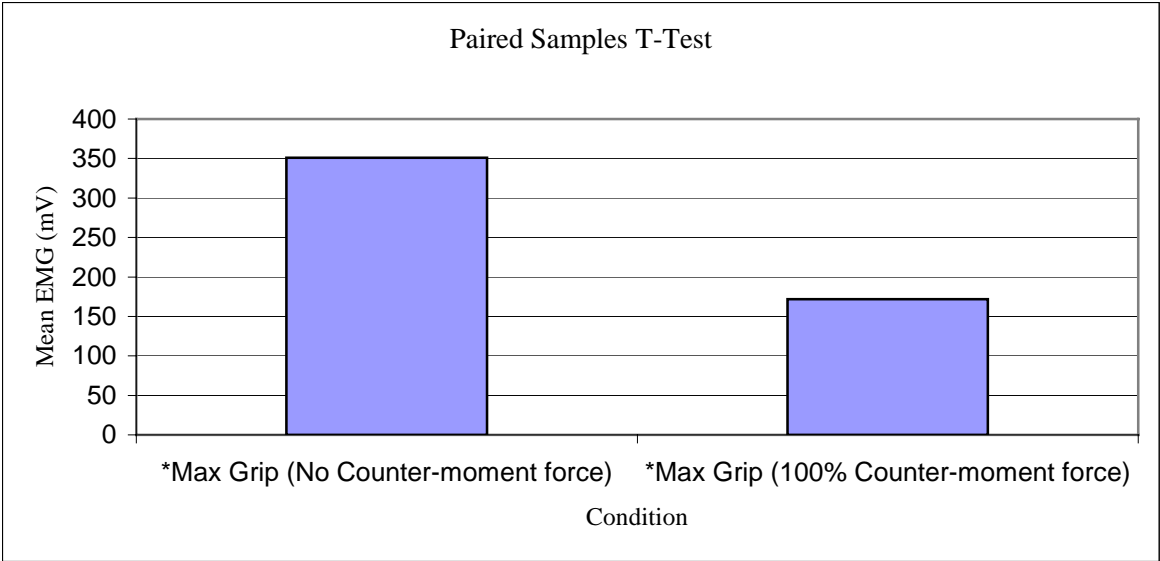

Figure 12: Maximum grip of handle without counter-moment and with 100% maximal counter-moment force. Asterisk indicates significant difference between Max Grip (no counter-moment force) and Max Grip (100% counter-moment force).

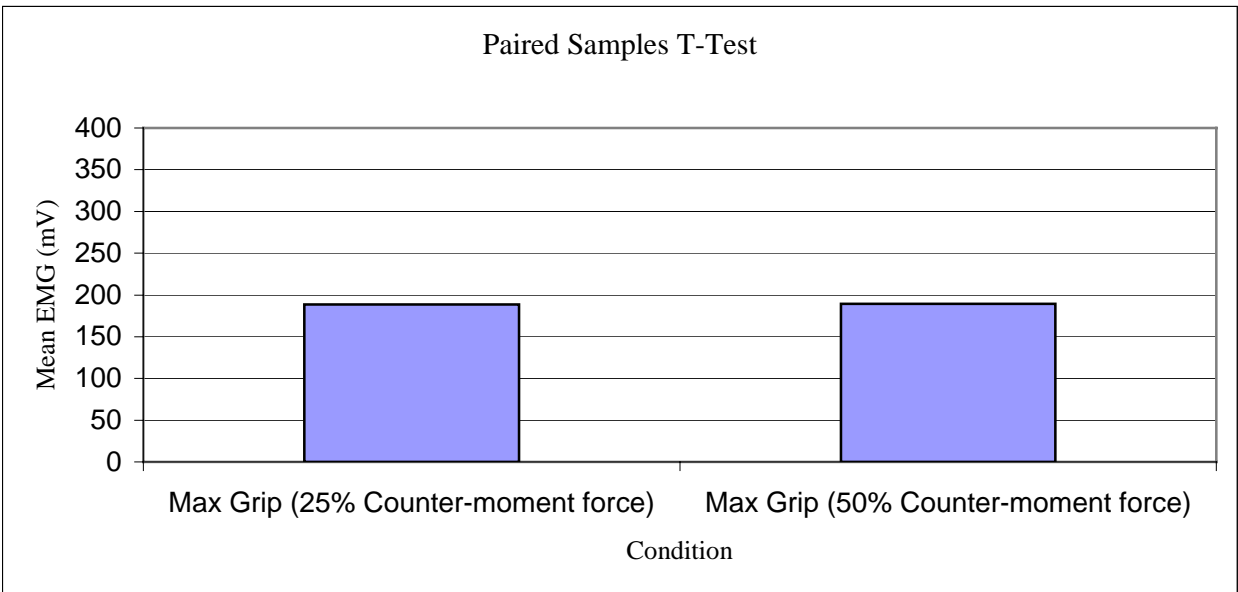

Figure 13: Maximum grip of handle with 25% counter-moment force and with 50% maximal counter-moment force. No significant difference between Max Grip (25% counter-moment force) and Max Grip (50% counter-moment force).

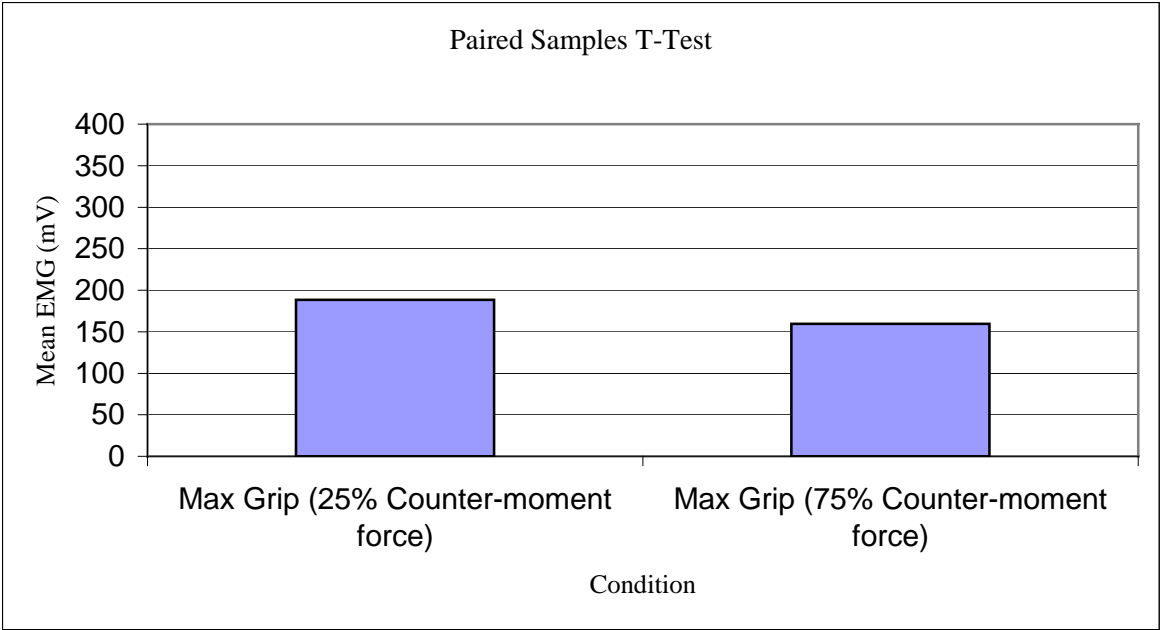

Figure 14: Maximum grip of handle with 25% counter-moment force and with 75% maximal counter-moment force. No significant difference between Max Grip (25% counter-moment force) and Max Grip (75% counter-moment force).

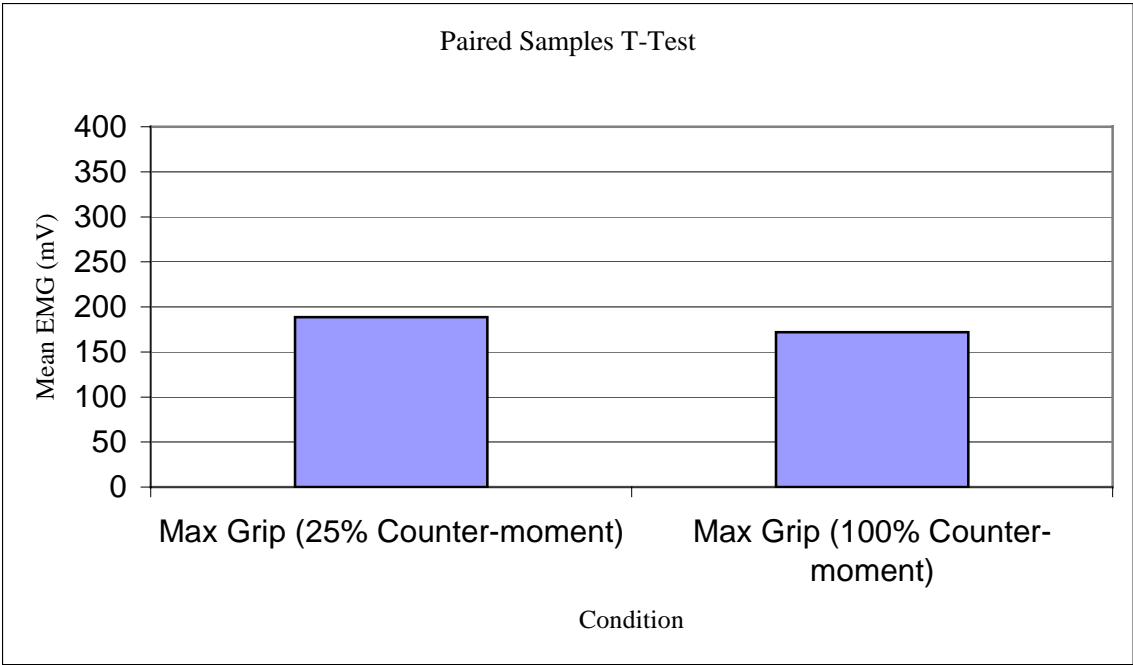

Figure 15: Maximum grip of handle with 25% counter-moment force and with 100% maximal counter-moment force. No significant difference between Max Grip (25% counter-moment force) and Max Grip (100% counter-moment force).

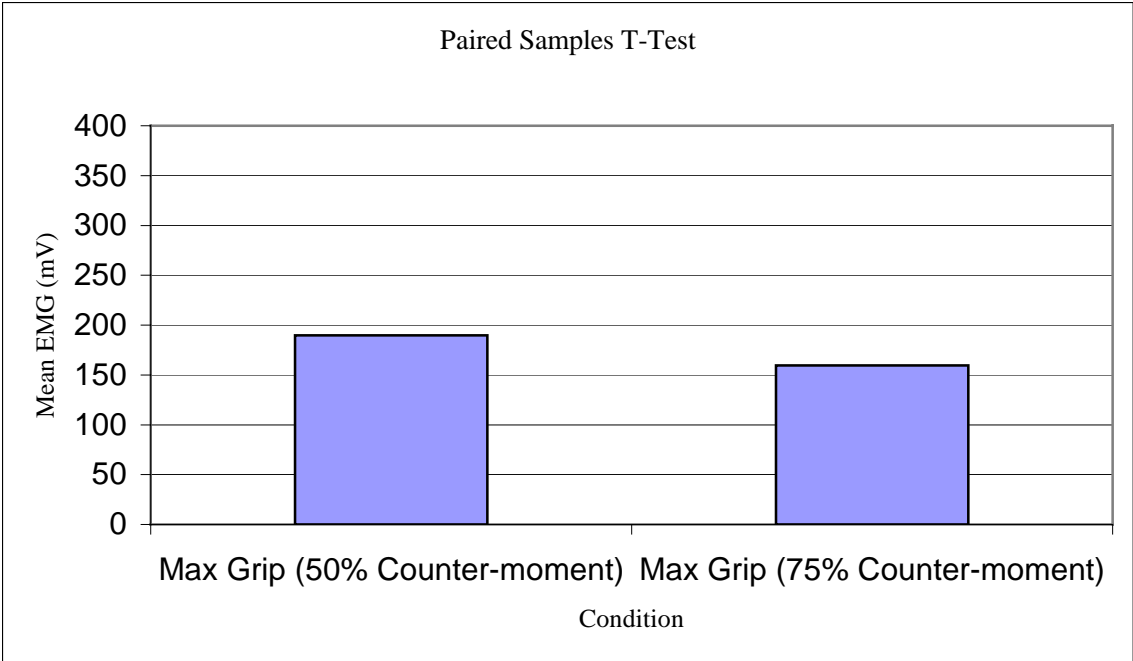

Figure 16: Maximum grip of handle with 50% counter-moment force and with 75% maximal counter-moment force. No significant difference between Max Grip (50% counter-moment force) and Max Grip (75% counter-moment force).

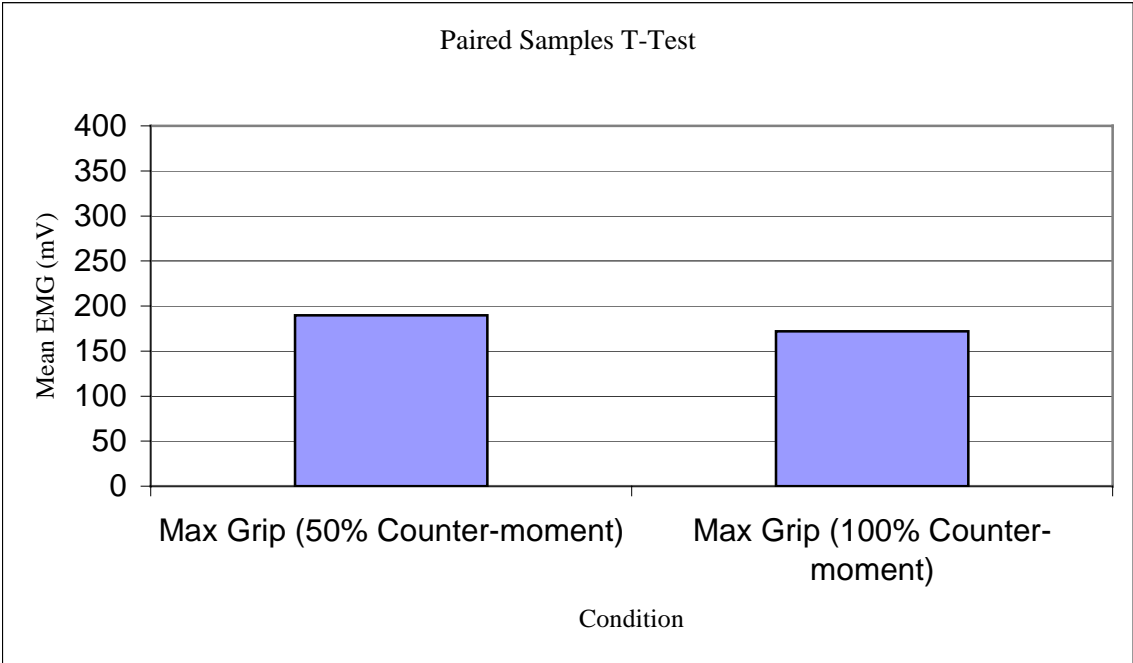

Figure 17: Maximum grip of handle with 50% counter-moment force and with 100% maximal counter-moment force. No significant difference between Max Grip (50% counter-moment force) and Max Grip (100% counter-moment force).



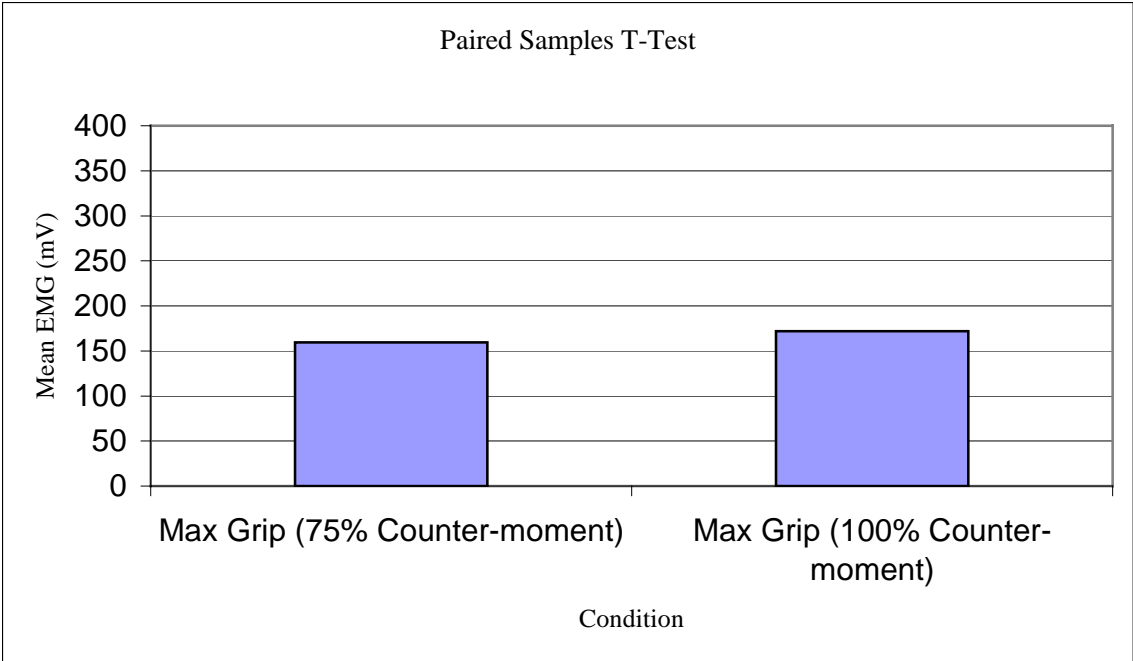

Figure 18: Maximum grip of handle with 75% counter-moment force and with 100% maximal counter-moment force. No significant difference between Max Grip (75% counter-moment force) and Max Grip (100% counter-moment force).

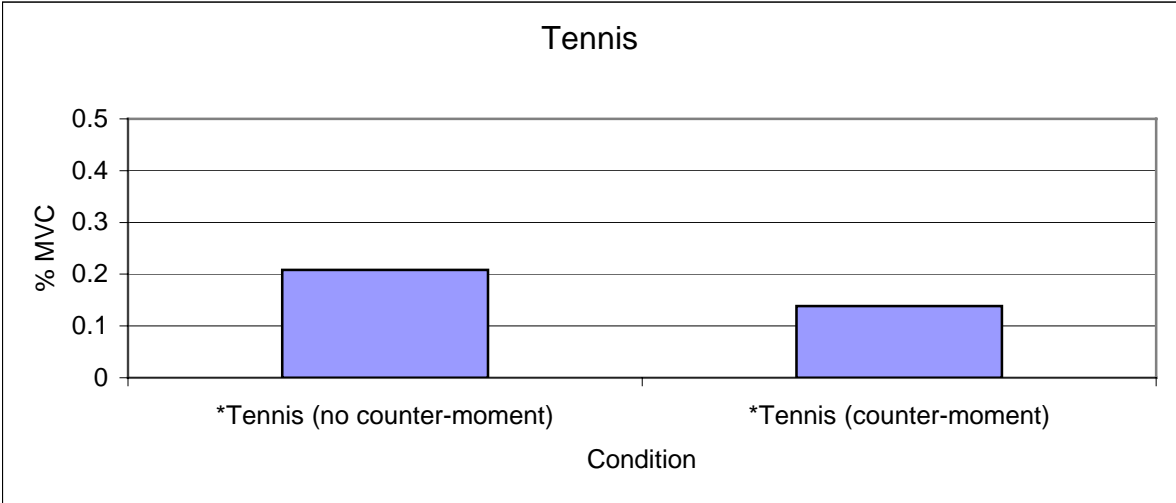

Figure 19: Paired Samples *t*-test between grip of tennis racket handle with and without counter-moment force. Asterisk indicates significant difference between Tennis no counter-moment force and Tennis counter-moment force.

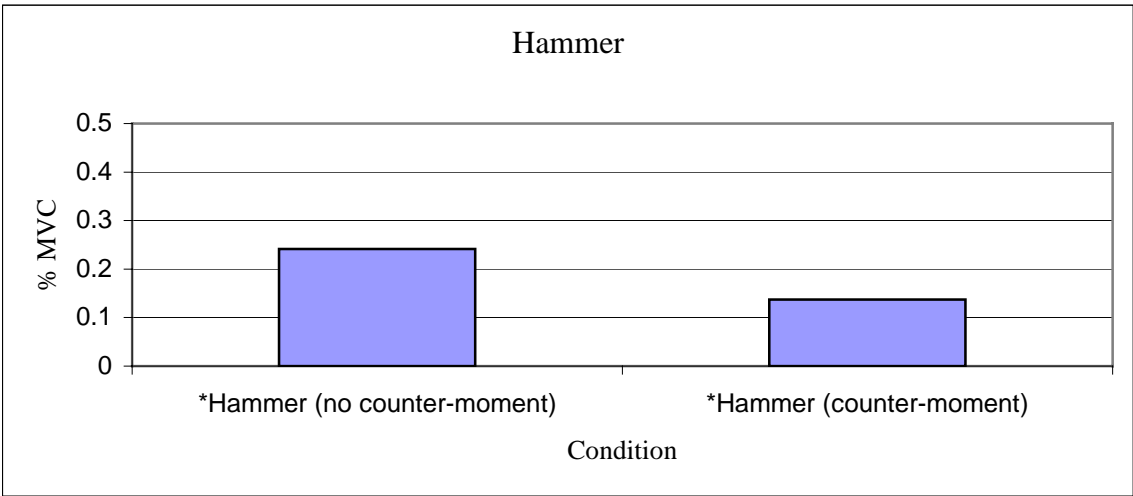

Figure 20: Paired Samples *t*-test between grip of a hammer with and without counter-moment force. Asterisk indicates significant difference between Hammer (no counter-moment force) and Hammer (counter-moment force).

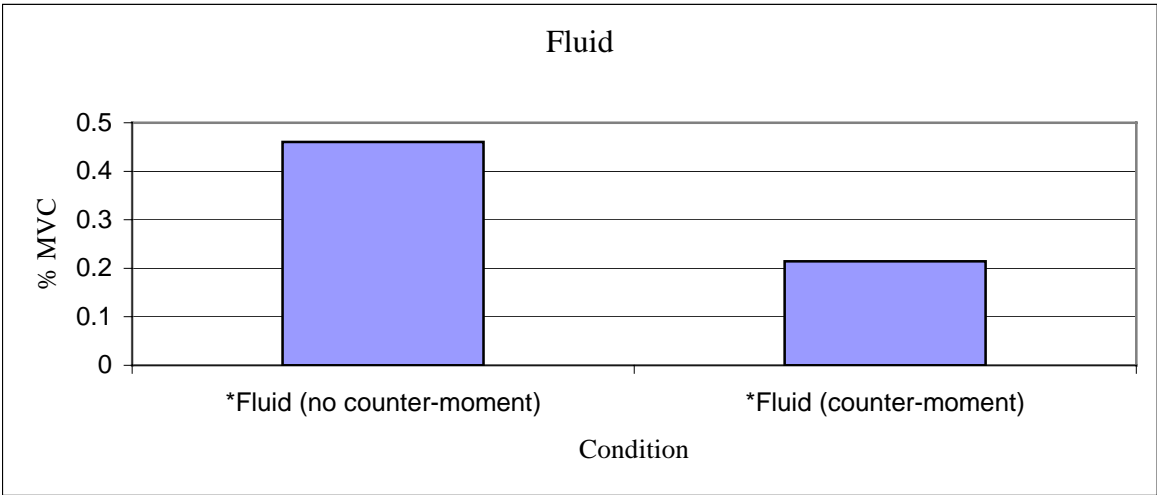

Figure 21: Paired Samples *t*-test between grip of a gallon of fluid with and without counter-moment. Asterisk indicates significant difference between fluid no counter-moment and fluid counter-moment gripping.

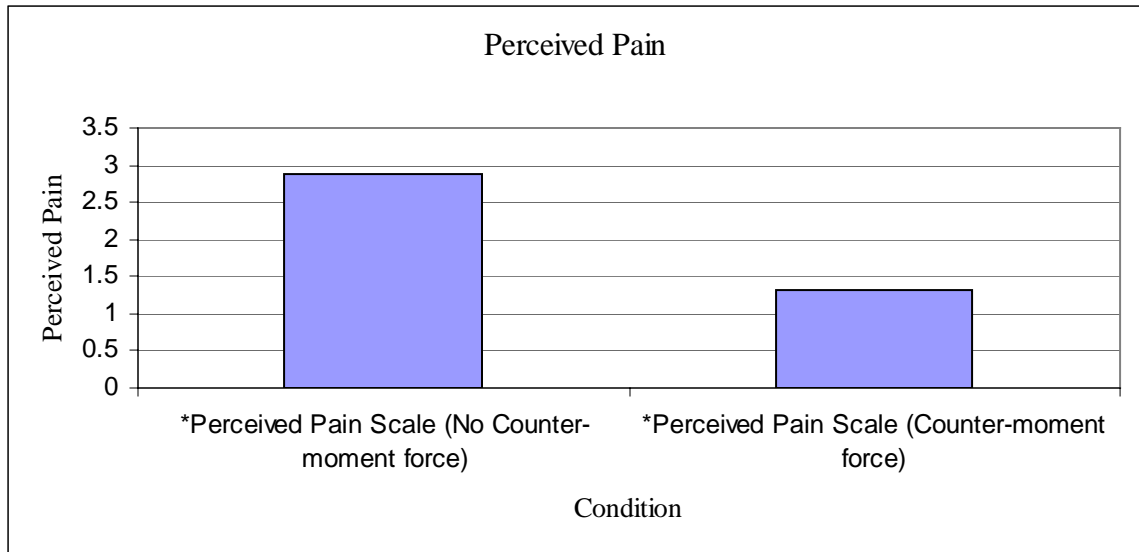

Figure 22: Paired Samples *t*-test between perceived pain scale with maximum grip of handle (No Counter-moment force) and (Counter-moment force). Asterisk indicates significant difference between Perceived Pain Scale (No Counter-moment force) and Perceived Pain Scale (Counter-moment force).

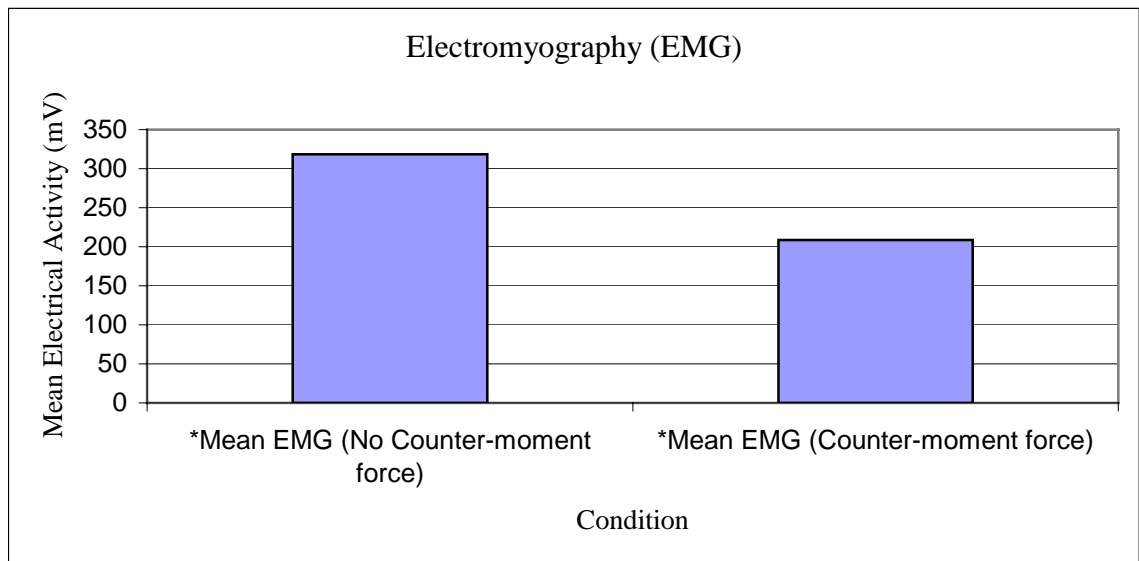

Figure 23: Paired Samples *t*-test between mean electrical activity (EMG) of the Extensor Carpi Radialis muscle (ECR) with maximum grip of handle (No Counter-moment force) and (Counter-moment force). Asterisk indicates significant difference between Mean EMG (No Counter-moment force) and Mean EMG (Counter-moment force).

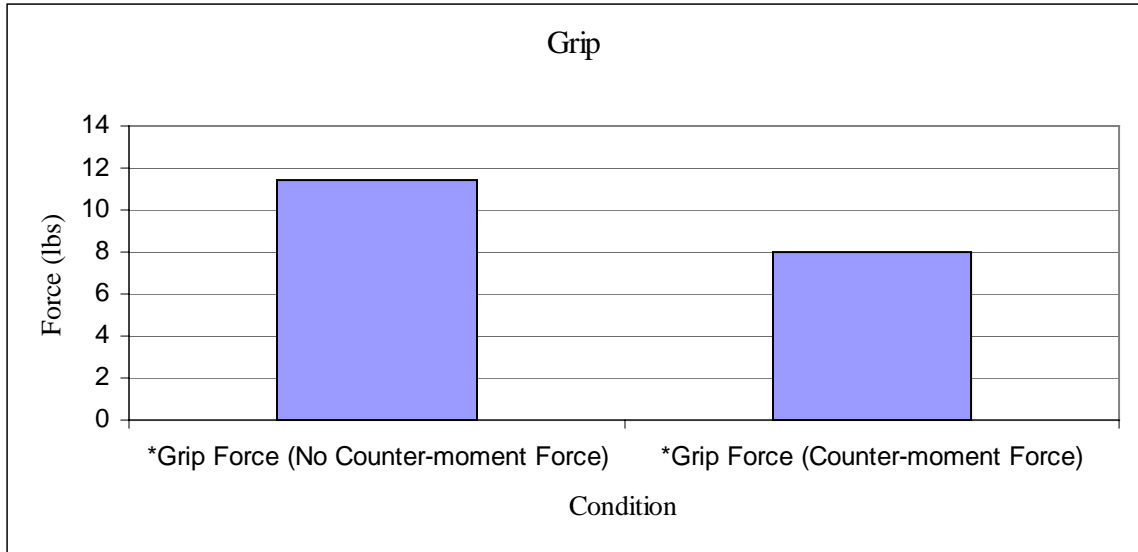

Figure 24: Paired Samples *t*-test between mean grip force (lbs) with maximum grip of handle (No Counter-moment Force) and (Counter-moment Force). Asterisk indicates significant difference between Grip force (No Counter-moment Force) and Grip force (Counter-moment Force).

Max Counter-moment	$F_{4,80}$	P	$\text{ETA}^2$	Power
1 x 5 Repeated Measures ANOVA	21.109	< .001	.513	1.00

Table 1: Statistical analysis for 1 x 5 repeated measures ANOVA for maximal counter-moment force.

Paired Condition	t	P
Max Grip (no counter-moment) & Max Grip (25% counter-moment)	5.719	<.001
Max Grip (no counter-moment) & Max Grip (50% counter-moment)	5.344	<.001
Max Grip (no counter-moment) & Max Grip (75% counter-moment)	5.698	<.001
Max Grip (no counter-moment) & Max Grip (100% counter-moment)	5.612	<.001
Max Grip (25% counter-moment) & Max Grip (50% counter-moment gripping)	-.080	=.937
Max Grip (25% counter-moment) & Max Grip (75% counter-moment gripping)	1.341	=.195
Max Grip (25% counter-moment) & Max Grip (100% counter-moment gripping)	.861	=.400
Max Grip (50% counter-moment) & Max Grip (75% counter-moment gripping)	1.583	=.129
Max Grip (50% counter-moment) & Max Grip (100% counter-moment gripping)	1.257	=.223
Max Grip (75% counter-moment) & Max Grip (100% counter-moment gripping)	-.620	=.543

Table 2: Paired Sample *t*-test follow up analysis for all possible within subject combinations.

Implement	No Counter-moment		With Counter-moment	
	X	SD	X	SD
Tennis	0.2084	0.12137	0.1387	0.14748
Hammer	0.2415	0.15937	0.1371	0.12026
Fluid	0.4604	0.24858	0.2146	0.17437

*Table 3:* The means and standard deviations for each implement with and without the external counter-moment force.

Implement	Significance	
	<u>t</u>	<u>P</u>
Tennis	2.555	p<0.05
Hammer	4.533	p<0.05
Fluid	4.582	p<0.05

*Table 4:* The t-scores and *P* values for each implement with and without the external counter-moment.

Symptomatic Counter-moment Force Perceived Pain	t	P	df
Paired Samples t-test	5.383	<.05	7

*Table 5:* Statistical analysis for paired samples *t*-test for Symptomatic Counter-moment Force Study (Perceived Pain).

Symptomatic Counter-moment Force EMG	t	P	Df
Paired Samples t-test	2.988	< .05	7

*Table 6:* Statistical analysis for paired samples *t*-test for Symptomatic Counter-moment Force Study (EMG).

## CHAPTER V. DISCUSSION

The purpose of this study was to investigate the influence of external wrist counter-moments on gripping and the muscle activity of symptomatic and non-symptomatic persons. There were three components to this project, and this chapter presents the findings and implications of those findings under the following headings: (1) Maximum Counter-Moment Force, (2) Task Counter-Moment, and (3) Symptomatic Counter-Moment. The final section summarizes the outcomes of each of the three studies and how the outcomes further the understanding of the etiology of tennis elbow. Lastly, suggestions for future research will be presented.

The primary objectives of this project were: (1) various wrist extension counter-moment forces would elicit a decrease in ECR activity during maximal gripping, (2) a fixed wrist extension counter-moment would elicit decreased ECR activity between fixed subject grip magnitudes, and (3) a fixed wrist extension counter-moment force would decrease perceived pain of symptomatic people when gripping.

### Maximum Counter-Moment

The Maximum Counter-Moment component of the present study examined how variable, manual, wrist extension counter-moment forces affected the muscle activity of the ECR during maximal gripping. The maximal counter-moment force was measured using manual resistance of the upper arm. Specifically, participants used their shoulder



adductors and internal rotators to achieve the maximal wrist extension counter-moment force measured via a force plate. Muscle activity was then measured during maximal gripping at 25%, 50%, and 75% of this maximal counter-moment force. Maximal grip with no counter-moment force was also measured and served as our baseline. The results demonstrate that the ECR muscle activity was significantly lower in all counter-moment force treatment trials compared to the non counter-moment force baseline trial, indicating that counter moments as low as 25% of maximal counter-force reduce the activity of the ECR. Interestingly, however, there was no significant difference between the non-maximum counter-force treatment trials, insinuating that the presence of a counter moment is important, not the magnitude. These findings suggest that any counter-moment between 25% and 100% will elicit a similar significant decrease in ECR muscle activity when compared to maximal gripping alone. Since the lower counter-moment force (25%) decreased ECR activity similarly compared to the higher counter-forces (50%, 75%, and 100%), there was no indication that using higher levels of counter-moment force are needed to achieve the desired result. This finding is valuable, for it leads to the recommendation of utilizing the smallest counter-moment force to assist people with signs and symptoms of tennis elbow. This recommendation is valid for the following two reasons: 1) the smallest counter-moment force produces the desired reduction of ECR activity, and 2) the smaller counter-moment force will provide less stress on the wrist flexors. Undo stress on the wrist flexors is contra-indicated. Increasing tone of the wrist flexors will create a greater imbalance between the wrist flexors and wrist extensors, which will demand greater output from the wrist extensors to maintain a neutral wrist posture during gripping.

This finding is especially important in the development of counter-moment devices, which may offer variable wrist extension resistance. Since there is no difference in the effect of variable wrist extensor counter-force from 25% to 100% on ECR activity, there is no need for an adjustable counter-moment device. More research is needed to examine the relationship between various wrist extension forces combined with various gripping magnitudes to determine if a moment less than 25% will elicit a concomitant decrease in ECR activity.

The outcomes of this portion of this study demonstrated that an external counter-moment force does reduce the activity of the ECR. This reduction of the ECR activity will place less stress on the ECRB origin, which is the location of most tennis elbow signs and symptoms. The next step is to determine if an external counter-moment device can be applied while individuals grip in recreational and occupational settings as well as grip objects used in activities of daily living that would elicit a decrease in ECR activity.

#### Task Counter-Moment

The Task Counter-Moment component of this study examined the influence of a fixed wrist extension counter-moment on the muscle activity of the ECR muscle during the gripping of three separate items. The findings of this study demonstrate that when gripping common items found in recreational and occupational activities, and activities of daily living, ECR activity decreased for each gripping task with the use of a wrist extension counter-moment when compared to gripping the items without the use of a wrist extension counter-moment. The following is a summary of each task counter-force findings separated by items.

### *Tennis*

The results for the tennis racket gripping task suggest that when an individual uses the same grip force to stabilize a tennis racket with and without the fixed external wrist extension counter-moment treatment; the counter-moment condition elicited decreased muscle activity of the ECR muscle significantly when compared to gripping alone (refer to Figure 13). In recreational settings, gripping an object such as a tennis racket, racquetball racket, or a golf club are tasks that are required for competition. Gripping of these recreational tools activates the wrist extensors as well as the wrist flexors, if the wrist is to be held in a neutral posture. Depending on the duration, magnitude, and frequency of play, these continuous stresses on the ECR origin may lead to symptoms of tennis elbow. The findings of this study indicate that the application of an external wrist extension counter-force during the gripping of the handles of recreational tools, such as a tennis racket, decreases the stress placed on the wrist extensors, of which the ECR is a part. In theory, the external wrist extension counter-moment would decrease the repetitive stress placed on the origin of the muscle, in recreational activities that require gripping.

### *Hammer*

The results from this component of this study also suggest that when an individual uses the same grip force to stabilize a hammer handle with and without the fixed external wrist extension counter-moment treatment, the treatment decreases the muscle activity of the ECR muscle significantly when compared to gripping alone. Gripping tools such as a hammer, welding torch, or jackhammer, are occurrences which are required in several occupational settings. The gripping of these occupational tools can lead to undue stress

of the wrist extensor muscles of which the ECR is a part. Factors such as gripping duration, gripping magnitude, and gripping frequency play key roles in repetitive stress injuries such as lateral epicondylagia. The application of an external wrist extension counter-moment force during the gripping of a hammer handle decreased the stress placed on the wrist extensors, (refer to Figure 14). Thus, continuous counter-moment force during gripping may lead to decreased repetitive stress on the ECR origin from occupational tasks, which require excessive gripping.

#### *Gallon of Fluid*

The last result from the task Counter Moment portion of this study suggests that when an individual uses the same grip force to stabilize a gallon of fluid with and without a fixed external wrist extension counter-force treatment, the treatment decreases the muscle activity of the ECR muscle significantly compared to gripping alone (refer to Figure 15). Gripping items such as a gallon of milk, can of food, or a steering wheel are occurrences, which are required for activities of daily living. Gripping items used in activities of daily living can lead to undue stress of the wrist extensor muscles of which the ECR is a part, particularly those items that have a weight distribution that favors a relatively long moment arm. Factors such as gripping duration, gripping magnitude, and gripping frequency play a key role in repetitive stress injury such as lateral epicondylagia. The application of an external wrist extension counter-force during the gripping of a gallon of fluid decreased the muscle activity of the wrist extensors. Thus a counter-moment force during gripping may lead to decreased repetitive strain on the ECR origin during activities of daily living, which, depending on the required activities, may require excessive gripping.

The results of this project support the previous research done by Van Elk et al. (2004), which suggested that an external wrist extension force decreases wrist extensor activity during gripping. The previous literature used fixed gripping magnitudes of 10%, 20%, and 30%, of maximal gripping magnitude. This study measured the gripping magnitude of each task directly, then matched that gripping magnitude combined with the counter-force treatment. This research project eliminated many of the limitations the previous study possessed on the subject of wrist extension counter-moment forces and its effects on ECR activity. The wrist extension counter-moment force, in this study, was applied through the handle of the object being gripped. This was beneficial since the wrist extension moment force was being applied through the gripping implement. The project methodology eliminated the need for a foreign object (wrist extension padding) to produce the wrist extension counter-force. Van Elks resistance padding, applying the wrist extension counter-force might have affected not only grip function but also metacarpal phalangeal position. Metacarpal phalangeal (MP) position is important since the more MP extension one has, the more ED activity and consequently, less ECR activity one will produce, due to the ECR shift (Campbell and Weimar unpublished)

The muscle activity of the ECR when grasping the gallon of fluid was significantly greater than that noted in the tennis racket and hammer trials ( $p < .05$ ), presumably because of the added weight of the fluid and the longer moment arm of the fluid condition as compared to the tennis and hammer conditions. The added load creates a greater ulnar deviation moment at the wrist joint. This greater ulnar deviation moment must be countered accordingly by the radial deviators, of which the ECR is also a part. The protocol of this study required that the tennis racket and the hammer be held in such

a manner that the moment arm with respect to gravity of each of these devices was minimized. However, in the case of the gallon of fluid, this arrangement was not possible. Therefore, there are three reasons that help to explain why the muscle activity of the ECR were so much larger during the fluid condition: (1) The weight of the fluid was greater than the tennis racket and the hammer, (2) the moment arm of the fluid with respect to gravity was longer than the tennis and hammer conditions and (3) the weight distribution of the fluid produced a larger ulnar deviation moment, than did either the tennis or the hammer conditions.

#### Symptomatic Counter-moment Force

Symptomatic persons with lateral epicondylagia (LE) report pain with tasks such as gripping/grasping. Van elk et al. (2004) investigated the use of a wrist extension device on symptomatic persons over a 6 month period. If the application of the wrist extension counter-moment force creates a decrease in the muscle activity of the ECR muscle, the immediate effects should be noticed in persons symptomatic with this pathology as decreased pain. This study furthers the literature in this regard. In the present study, persons symptomatic with LE reported a significant decrease in pain (see figure 22) and demonstrated lower EMG amplitude (see Figure 23) with the application of an external wrist extension counter-moment force. However, the finding of the decrease in pain and decreased EMG magnitude noted by the symptomatic persons of the present study should be read with caution, as grip force decreased as well (see Figure 24). Specifically, the grip force was shown to be significantly less with the application of the external wrist counter-moment force. Therefore, it is impossible to determine the causal relationship between the presence of the counter-moment force and the noted decrease in

pain and EMG activity. While the results of this study are promising, further research is needed to determine the exact relationship between the presence of a counter-moment force and pain, in persons who are symptomatic with LE.

The use of a wrist extension counter-moment for persons symptomatic with lateral epicondylagia has many implications. Rehabilitation of injuries is sometimes a very long process. The ability of damaged tissue to repair itself is dependant on many factors, of which is the relationship between tissue damage versus tissue healing. Damage to the ECR origin can occur through various activities, which may occur at work or at home. When these activities cease, the tissue has a chance to repair the cumulative trauma. If the use of a wrist extension counter-moment force allows for less cumulative trauma placed on the extensor mass through decreased EMG activity, it is plausible to assume that there would be less damage to the tissue. The decrease in tissue damage would in turn allow for faster healing, since the ratio of tissue damage to tissue repair would be better suited for healing.

An encouraging finding of this present study is the decrease in pain noted by the symptomatic persons while using the counter-moment force device. The mechanism by which the counter-moment force device induced this decrease in pain is not clear. However, it is reasonable to suggest that the decrease in EMG activity, noted in the presence of the counter-moment force device, would account for less stress being placed upon the injured tendon. Therefore, the application of an external counter-moment could allow persons with LE to function in activities of daily living/work with less stress placed on the ECR muscle. Less stress to the muscle origin would mean greater healing potential from rehabilitation exercises. The use of this counter-moment force would not

take the place of therapy, but would be used in conjunction with rehabilitation. The ultimate goal is to eventually have symptomatic persons working/living pain free with no assistance. Rehabilitation (repair) as well as counter-moment force devices (less damage) are two major components to the ultimate goal of pain free living/working with persons who are living with the symptoms of LE.

### Tennis Elbow

The etiology of tennis elbow is still not well defined (Snijders 1987; Roeter 1995; Ljung 1999). The most prevailing theories regarding the development of tennis elbow are due to the eccentric loading of the wrist extensors during activities such as the backhand stroke in tennis. However, our data support the theory of gripping as an etiology of tennis elbow. This culprit was first suggested as an answer to the observation that occupational workers, non-recreational persons, as well as recreational athletes, suffer from the symptoms of lateral epicondylalgia, and the common factor across activities from each of these categories is gripping. Since gripping activates the wrist extensors to counter the induced wrist flexion moment produced by the finger flexors, chronic overuse of this muscle can lead to degenerative changes such as those found in lateral epicondylalgia. Researching ways to minimize stress on this common wrist extensor origin is important to recreational athletes, occupational workers, and persons undergoing activities of daily living.

Minimizing stress on the ECR origin, as was achieved in this study, can assist recreational athletes by removing pain as a limiting factor with regard to performance. Less discomfort would allow greater concentration as well as greater physical exertion in



the upper body. Decreasing chronic strain of the ECR on the lateral epicondyle can assist occupational workers by decreasing time missed due to injury. Decreasing workman's compensation would also save companies time and money. In 2001, the Bureau of Labor Statistics found that 70% of all work related illnesses were from repetitive strain injuries such as lateral epicondylagia. The Bureau also reported that the cost of these repetitive strain injuries cost companies \$20 billion annually. The findings of this study would also be useful for persons performing activities of daily living, such as gardening, painting, and working on arts and crafts. Decreasing stress on the ECR origin would allow persons to enjoy activities such as these for greater periods of time.

#### Future Research

Future research in the area of wrist extension counter-moments could investigate on gripping magnitude and counter-moment variations, as well as manual resistant counter-moment applications and its effects on ECR activity when gripping. Counter-moment force and grip magnitude combinations could be studied to explain which combinations work more effectively in relieving stress on the ECR muscle origin. This research used 25% MVC as its lowest level of counter-moment. This level was just as effective in decreasing ECR activity as maximal counter-moment intensity. Future studies could investigate forces lower than 25% to ensure that lower magnitudes would also elicit similar changes to the ECR activity, when gripping.

The most basic of counter-moment devices is the manual application of a counter-moment from the non-gripping hand. Not only would this counter-moment be affordable, but it could be applied when needed (i.e. gripping). In the case of gripping a gallon of

fluid, the counter-force application could be applied by the non-gripping hand, creating a wrist extension moment from the fluid to the wrist. Unlike a device that would create a constant wrist extension moment, the manual moment could cease as soon as the gripping task is completed and would be inherently adjustable. Not only would this technique be more affordable and applicable, but also more convenient. This unique approach to manual resistance counter-moment force application can be tested in future studies for a variety of gripping tasks and counter-moment force magnitudes.

A device that provides a constant wrist extension counter-moment force may be indicated for the decrease in wrist extensor EMG activity, however this extra moment must be balanced, continuously, by the wrist flexors. The wrist flexors are tonic in nature. The added demand of the constant counter-moment force to the already tonic wrist flexors would lead to an even greater imbalance between the strength and endurance of the wrist flexors and the wrist extensors. Van Elk et al. 2004, proposed just such a device. The device proposed by Van Elk et al. 2004 is made from molded plaster and contours to the palmar surface of the hand. The plaster then forms a hardened shell from which the wrist extension force is applied. Since a counter-moment would only be indicated during gripping, the device proposed by Van Elk et al. 2004, would continuously innervate the wrist flexors though gripping had ceased. Acute devices designed to decrease the muscle activity of the wrist extensor muscles do not fix the underlying problem, but rather suppress the overlying symptoms. Future devices, whether it be a fixed or manual counter-moment force, should only be used as a supplement to rehabilitation exercises and treatment under the care of a physician.

Manual resistance from the opposite hand/arm could produce such a manual resistance counter-moment force. This manual resistance counter-moment would only be applied when indicated by pain/discomfort when gripping. The findings of the present study suggest that the counter-moment should be at least 25% of maximal manual resistance wrist extension counter-force. Another approach would be a counter-moment force that could attach directly to the implement. Thus not altering the handgrip dynamics of the tool, yet freeing up the opposite hand for other tasks. The external wrist extension counter-moment force could attach via cable, strings, and resistance band from the forearm to the implement supplying the counter-force.

To this point, only one other research group has proposed a counter-moment system to assist those suffering from lateral epicondylitis. In 2004, Van Elk et al. put forth a wrist external counter-moment system that requires the sufferer to wear a hard plastic shell that crosses the palmar surface of the hand. However, the Van Elk et al. approach has two major limitations for symptomatic persons who may utilize a counter-moment to decrease acute and chronic symptoms. First, the presence of an external, bulky object situated in the palm of the hand, may alter normal gripping and grasping mechanics. This inability to naturally grip due to an external object in the palm of the hand is a limitation. The second limitation of the Van Elk et al. approach is the constant moment that is created by the device. The purpose of the counter-moment is to assist during gripping activities, however the device presented in the Van Elk et al. (2004) study is constantly supplying a counter-moment, even when the wearer is not gripping. This increased demand on the flexor mass can actually lead to further development of the flexors, and put added, undue stress on the extensors to counter during the gripping. An

alternative approach would be to create a temporary adjustable, counter-moment, which could be applied when needed.

Future research should also focus on the exact cause of decreased pain and EMG amplitude when using a wrist extension counter-moment force. Does the extension moment elicit decrease ECR activity because of the decreased need for the ECR to serve as a counter-moment? Or does the ECR lessen its activity in the presence of a counter-moment force due to the attenuation created by the counter-moment force? Understanding the exact mechanism of the decrease muscle activity as well as decrease perceived pain in symptomatic persons should be investigated more thoroughly.

The use of counter-moment force techniques to decrease activity of the ECR is different from other well-established braces used for the treatment of lateral epicondylagia. Instead of tacking down the wrist extensor origin in an effort to create a new origin, as is the role of the compression elbow straps, a counter-moment force would directly influence the activity of the muscle during gripping. The forearm strap only changes the location of the origin of the muscle from which the muscle is pulling.

## Limitations

### *Maximum Counter-moment Force*

Limitations of the maximum counter-moment force research include not controlling for grip intensity. Methods called for maximal gripping for each of the five trials. To confirm maximal gripping intensity a force output measure would have been ideal. Variations of the counter-moment force intensity could have had an effect on maximal gripping. For instance, maximal gripping with maximal counter-moment force

trial may elicit a more consistent maximal grip than a trial that included maximal gripping and submaximal counter-moment force. Having to perform two tasks, with one being an all out effort and the other being a sub maximal effort might influence both tasks being measured. Controlling for grip intensity would have assisted in alleviating this dilemma. If various counter-moment force intensities influences maximal gripping, this issue can be addressed in a future research study. The outcome measure of ECR activity however only focused on the combination of the two tasks (max gripping and wrist extension counter-force magnitude) and not explaining the relationship between the two.

#### *Task Counter-moment Force*

The primary limitation of the task counter-moment force study was not standardizing ulna deviation moment in pre and post conditions. Pre conditions required the gripping of a tennis racket, hammer, and gallon of fluid. Identical handles were then placed in the counter-moment force devices for the participants to match grip intensities with pre condition grip force. Since the ECR is activated with wrist extension as well as radial deviation, and the participants were placed in a semipronated position, the ECR would be subjected to greater activity due to the ulna deviation moments created by the racket, hammer, and the fluid. These ulna deviation moments were not elicited with the counter-moment force trials due to the implement used to create the moment. The handles of the three task implements were removed and placed within the counter moment force device. This removed the ulna deviation moment component of the task. By not controlling for ulna deviation moment, ECR activity may be decreased for each trial. This is based on absence of the ulnar deviation moment at the wrist in

counter-moment force conditions. The counter-moment force device did not allow for active or passive deviations of the wrist joint, thus not allowing an ulnar deviation moment. The absence of this moment in post trials, might have influenced the ECR activity.

### *Symptomatic Counter-moment Force*

Limitations with the symptomatic counter-moment force section include the inability to match mean grip intensity in both gripping conditions (no counter-moment force and counter-moment force). This limitation however will be addressed in future research on the topic. The use of a subjective pain scale measure leaves room for error. Symptomatic persons whom rated perceived pain could have many factors influencing their score. One of these factors could be giving a pain scale score based on what they think we wanted, or what they think they should give, and not giving a score based on perceived pain alone.

### Summary

The use of an external wrist extension counter-moment force decreases ECR activities such as gripping a tennis racket handle, hammer handle, and a gallon of fluid. These findings can be useful in assisting people with lateral epicondylagia as well as preventing it in persons predisposed to the condition, by decreasing repetitive strain on the muscle most commonly associated with the pathology. Manual resistance counter-moment force of at least 25% of maximal counter-moment force also decreases ECR when combined with maximal gripping. Higher levels of manual counter-moment force

intensity also significantly decrease ECR activity when compared to gripping alone, but they do not however differ from 25%. Therefore, a manual wrist extension counter-moment force of at least 25% of MVC is recommended when applying a manual counter-moment force since this force will be less stressful on the wrist flexors, as well as respond similarly to higher levels of counter-moment forces. This research has advanced the literature on 3 main levels. (1) The use of an external wrist counter-moment force which does not limit gripping mechanics or finger range of motion decreases muscle activity of wrist extensors. (2) External wrist counter-moment force intensity does not significantly vary in magnitudes of 25%, 50%, 75%, and 100% of maximal counter-moment force. (3) The application of an external wrist extensor counter-moment force decreases perceived pain in persons symptomatic with LE during maximal gripping. The decrease in pain however cannot be attributed directly to the counter-moment force however, due to participants unable to match maximal grip force during counter-moment trials. More research is needed to determine the exact mechanism of decreased perceived pain during maximal gripping in symptomatic persons when using an external wrist extension counter-moment force. Other areas should focus on manual resistance counter-moment forces to assist symptomatic persons in performing activities of daily work and living.

## REFERENCES

- Blackwell, J. B., Cole, K. J. (1994). Wrist kinematics differ in expert and novice tennis players performing the backhand stroke: implications for tennis elbow. *Journal of Biomechanics* **27**(5): 509-16.
- Boyd , H. B., McLeod, A. C. (1973). Tennis elbow. *Journal of Bone and Joint Surgery* **55**(6): 1183-7.
- Boyer, M., Hastings, H. (1999). Lateral tennis elbow: "Is there any science out there?". *Journal of Shoulder and Elbow Surgery* **8**(5): 481-91.
- Bunnell, S. (1944). *Surgery of the Hand*. Philadelphia, J.B. Lippincott.
- Bylak, J., Hutchinson, M. R. (1998). Common sports injuries in young tennis players. *Sports Medicine* **26**(2): 119-32.
- Cabrera, J. M., McCue, F. C. (1986). Nonosseous athletic injuries of the elbow, forearm, and hand. *Clinics in Sports Medicine* **5**(4): 681-700.
- Ciccotti, M. G., Charlton, P. H. (2001). Epicondylitis in the athlete. *Clinics in Sports Medicine* **20**(1): 77-93.
- Cooney, W. P. (1984). Sports injuries to the upper extremity. How to recognize and deal with some common problems. *Postgraduate Medicine* **76**(4): 45-50.



- Coonrad, R. W., & Hooper, W. R. (1973). Tennis elbow: its course, natural history, conservative and surgical management. *Journal of Bone and Joint Surgery* **55**(6): 1177-82.
- Cyriax, J. H. (1939). The pathology and treatment of tennis elbow. *Journal of Bone and Joint Surgery* **18**: 921.
- Durbin, F. C. (1966). Tennis elbow. *Nursing Times* **62**(18): 609-10.
- Elliott, B. C. (1982). Tennis: the influence of grip tightness on reaction impulse and rebound velocity. *Medicine and Science in Sports and Exercise* **14**(5): 348-52.
- Faes, M., Van Elk, N., De Lint, J. A., Degens, H., Kooloos, J.G., & Hopman, M. T. (2006). A dynamic extensor brace reduces electromyographic activity of wrist extensor muscles in patients with lateral epicondylagia. *Journal of Orthopaedic & Sports Physical Therapy* **36**(3): 170-8.
- Greig, M., & Wells, R. (2004). Measurement of prehensile grasp capabilities by a force and moment wrench: methodological development and assessment of manual workers. *Ergonomics* **47**(1): 41-58.
- Gruchow, H. W., & Pelletier, D. (1979). An epidemiologic study of tennis elbow. Incidence, recurrence, and effectiveness of prevention strategies. *American Journal of Sports Medicine* **7**(4): 234-8.
- Hatze, H. (1976). Forces and duration of impact, and grip tightness during the tennis stroke. *Medicine and Science in Sports and Exercise* **8**(2): 88-95.

- Henning, E. M., Rosenbaum, D., & Milani, D. (1992). Transfer of tennis racket vibrations onto the human forearm. *Medicine and Science in Sports and Exercise* **24**(10): 1130-1140.
- Hoppenfeld, S. (1976). Physical Examination of the Spine and Extremities. Norwalk, Appleton-Century-Crofts.
- Jensen, B., Savnik, A., Bliddal, H., & Danneskiold-Samsoe, B. (2001). Lateral humeral epicondylitis--"tennis elbow". I. Epidemiology, clinical picture and pathophysiology. *Ugeskrift For Laeger* **163**(10): 1417-21.
- Jobe, F. W., & Ciccotti, M.G. (1994). Lateral and Medial Epicondylitis of the Elbow. *Journal of the American Academy of Orthopaedic Surgeons* **2**(1): 1-8.
- Kelley, J. D., Lombardo, S. J., Pink, M., Perry, J., & Giangarra, C. E. (1994). Electromyographic and cinematographic analysis of elbow function in tennis players with lateral epicondylitis. *American Journal of Sports Medicine* **22**(3): 359-63.
- Kida, O. S. (2001). Neuromuscular fatigue during maximal concurrent hand grip and elbow flexion or extension. *Journal of Electromyography and Kinesiology* **11**(4): 281-289.
- Knight, J. F., & Baber, C. (2004). Neck muscle activity and perceived pain and discomfort due to variations of head load and posture. *Aviation Space and Environmental Medicine* **75**(2): 123-31.
- Kohn, H. S. (1984). Current status and treatment of tennis elbow. *Wisconsin Medical Journal* **83**(3): 18-9.

- Kreighbaum, E., Barthels, K. M. (1981). *BIOMECHANICS A Qualitative Approach for Studying Human Movement*. Minneapolis, Burgess Publishing Company.
- Leach, R. E., & Miller, J. K. (1987). Lateral and medial epicondylitis of the elbow. *Clinics in Sports Medicine* **6**(2): 259-72.
- Lieber, R. L., & Friden, J. (1997). Sarcomere length in wrist extensor muscles. Changes may provide insights into the etiology of chronic lateral epicondylitis. *Acta Orthopaedica Scandanavia* **68**(3): 249-54.
- Ljung, B., Friden, J., & Lieber, R. L. (1999). Sarcomere length varies with wrist ulnar deviation but not forearm pronation in the extensor carpi radialis brevis muscle. *Journal of Biomechanics* **32**(2): 199-202.
- Loren, G. J., and Lieber, R. L. (1995). Tendon biomechanical properties enhance human wrist muscle specialization. *Journal of Biomechanics* **28**(7): 791-799.
- Loren, G. J., Shoemaker, S. D., Burkholder, T. J., Jacobson, M. D. , Friden, J., & Lieber, R. L. (1996). Human wrist motors: biomechanical design and application to tendon transfers. *Journal of Biomechanics* **29**(3): 331-342.
- Luttgens, H. a. (1997). *KINESIOLOGY Scientific Basis for Human Movement*. Boston, WCB McGraw-Hill.
- Mackay, D., Rangan, A., Hide, G., Hughes, T., & Latimer, J. (2003). The objective diagnosis of early tennis elbow by magnetic resonance imaging. *Occupational Medicine* **53**(5): 309-312.
- Moore, J. S. (2002). Biomechanical models for the pathogenesis of specific distal upper extremity disorders. *American Journal of Industrial Medicine* **41**(5): 353-69.
- Murtagh, J. E. (1988). Tennis elbow. *Australian Family Physisian* **17**(2): 90-5.

- Neumann, H. D. (1989). *Manual Medicine*, Springer Verlag.
- Nirschl, R. P. (1973). Tennis elbow. *Orthopaedics of North America* **4**(3): 787-800.
- Nirschl, R. P., & Pettrone, F. A. (1979). Tennis elbow. The surgical treatment of lateral epicondylitis. *Journal of Bone and Joint Surgery*. **61**(6A): 832-9.
- Nirschl, R. P., & Kraushaar, B. S. (1996). Assessment and Treatment Guidelines for Elbow Injuries. *The Physician and Sportsmedicine* **24**(5).
- Oda, S., & Kida, N. (2001). Neuromuscular fatigue during maximal concurrent hand grip and elbow flexion or extension. *Journal of Electromyography and Kinesiology* **11**(4): 281-289.
- Prentice, W. E. (1999). *Rehabilitation Techniques in Sports Medicine*. Boston, WCB/McGraw-Hill.
- Rauch (1989). *Kinesiology and Applied Anatomy*. Philadelphia, Lea and Febiger.
- Roetert, E. P., Brody, H., Dillman, C. J., Groppe, J. L., & Schultheis, J. M. (1995). The biomechanics of tennis elbow. An integrated approach. *Clinics in Sports Medicine* **14**(1): 47-57.
- Smith, R. W., Mani, R., Cawley, M. I., Englisch, W., & Eckenberger, P. (1993). Assessment of tennis elbow using the Marcy Wedge-Pro. *British Journal of Sports Medicine* **27**(4): 233-6.
- Snijders, C., Volkers, C. W., Mechelse, K., Vleeming, A. (1987). Provocation of epicondylalgia lateralis (tennis elbow) by power grip or pinching. *Medicine and Science in Sports and Exercise* **19**(5): 518-23.

- Soderberg, G. L. (1992). Recording Techniques. *Selected Topics in Surface Electromyography for Use in the Occupational Setting: Expert Perspectives*. G. L. Soderberg, U.S. Department of Health and Human Services: 31-5.
- Starkey (1993). *Therapeutic Modalities for Athletic Trainers*. Philadelphia, F.A. Davis Company.
- Thompson, C. W. (2004). *Manual of Structural Kinesiology*. New York, McGraw-Hill.
- Ulin, S. S., Armstrong, T. J., Snook, S. H., & Keyserling, W. M. (1993). Perceived exertion and discomfort associated with driving screws at various work locations and at different work frequencies. *Ergonomics* **36**(7): 833-46.
- Van Elk, N., Faes, M., Degens, H., Kooloos, J. G., de Lint, J. A., & Hopman, M. T. (2004). The application of an external extension force reduces electromyographic activity of wrist extensor muscles during gripping. *Journal of Orthopaedic & Sports Physical Therapy* **34**(5): 228-34.
- Verhaar, J., Walenkamp, G., Kester, A., van Mameren, H., & Lindon, T. (1993). Lateral Extensor Release for Tennis Elbow. A Prospective Long-Term Follow-up Study. *The Journal of Bone and Joint Surgery* **75-A**(7): 1034-1043.
- Vicenzino, B., Collins, D., & Wright, A. (1996). The initial effects of a cervical spine manipulative physiotherapy treatment on the pain and dysfunction of lateral epicondylalgia. *International Association for the Study of Pain* **68**(1): 69-74.
- Watanabe, T., Ikegami, Y., & Miyashita, M. (1979). Tennis: the effects of grip firmness on ball velocity after impact. *Medicine and Science in Sports and Exercise* **11**(4): 359-61.

Wells, R., & Greig, M. (2001). Characterizing human hand prehensile strength by force and moment wrench. *Ergonomics* **44**(15): 1392-402.

APPENDIX A. INFORMED CONSENT FORM MAX COUNTER-MOMENT FORCE

## INFORMED CONSENT

For a Study Entitled:

Counter-moment Magnitude and Extensor Carpi Radialis Activity

You are invited to participate in a study of the relationship of various muscles in your forearm as they relate to tennis elbow. You were contacted because you are a student at Auburn University between the ages of 19 and 25. With your help it is hoped that the mechanism for tennis elbow (lateral epicondylitis) can be better understood. You were selected as a potential participant because of your age and the fact that your health condition and mobility permit you to perform the tests safely and successfully.

The purpose of this study is to assess the muscular activity of the Extensor Carpi Radialis (ECR) muscle during gripping in conjunction with various magnitudes of wrist extension counter-moments. Specifically the following questions will be assessed. (1) Does the activity of the ECR go silent when a maximal wrist extensor counter moment is applied? (2) How do various sub-maximal wrist extension counter moments affect the %MVC of the ECR muscle? The experiment will last approximately 45 minutes (this includes the time necessary for you to fill out the forms, and undergo all testing procedures. Your data will be collected using the following methods (by volunteering to participate in this study you agree to be tested in the following testing protocols):

**Maximum Isometric Grip with Maximum Isometric Counter moment:** You will be asked to sit in our testing chair and maximally grip a tennis racket while simultaneously maximally applying force down on our force plate (through a solid medium) with your wrist muscles.

**Maximum Isometric Grip with Sub-maximal Isometric Counter moment:** You will be asked to sit in our testing chair and maximally grip a tennis racket while simultaneously applying 25, 50, and then 75% of your maximal recorded wrist counter moment force through a solid medium to the force plate for 2 seconds in each sub-maximal trial (3 total).

**Participants Initials** \_\_\_\_\_



There are 2 main risks of concern with regard to these testing protocols. First, the use of a razor for shaving EMG site placement areas can cause skin irritations. The EMG pads may also cause skin irritation at the placement sites. If symptoms are very severe, subjects will be advised to seek assistance at the Auburn University Health Clinic or hospital immediately at participant's own cost. The second classification of risk associated with volunteering in this study is orthopedic in nature. Muscle strains or joint sprains can occur during the maximum isometric contractions. Also muscle soreness can occur for up to 7 days following strenuous muscle activity such as maximum isometric muscle contractions. If symptoms are very severe, seek assistance at the Auburn University Health Clinic or hospital immediately at participant's own cost. We feel that through proper instruction and the use of spotters, that these risks will be very minimal.

There are two main benefits the general population can gain from this study. (1) The etiology of tennis elbow can hopefully be better understood. (2) Grip intensity as a function of wrist extensor muscle activity can be applied to future development of braces that can help symptomatic persons with tennis elbow.

Any information obtained in connection with this study that can be identified with you will remain confidential. Your participation identification number will be destroyed within one year of completing this study.

Your decision whether or not to participate will not jeopardize your future relations with Auburn University or the Department of Health and Human Performance. Further, you may discontinue participation at any time without penalty. If you decide later to withdraw from the study you may also withdraw any identifiable information, which has been collected about you, in this study.

If you have any questions now or later, please feel free to contact Brian Campbell or Dr. Wendi Weimar at (334) 844-1468. You will be given a copy of this form to keep.

For more information regarding your rights as a research participant you may contact the Auburn University Office of Human Subjects Research or the Institutional Review Board by phone (334) 844-5966 or e-mail at [hsubjec@auburn.edu](mailto:hsubjec@auburn.edu) or [IRBChair@auburn.edu](mailto:IRBChair@auburn.edu). **YOU ARE MAKING A DECISION WHETHER OR NOT TO PARTICPATE. YOUR SIGNATURE INDICATES THAT YOU HAVE DECIDED TO PARTICIPATE HAVING READ THE INFORMATION PROVIDED ABOVE.**

---

Date

---

Time

---

Participant's Signature

---

Investigator's Signature

APPENDIX B. INFORMED CONSENT FORM TASK COUNTER-MOMENT FORCE

INFORMED CONSENT  
for a research study entitled,  
“Wrist counter-moment effects on various task gripping magnitudes”

You are invited to participate in a research study of the relationship of various muscles in your forearm as they relate to tennis elbow. You were contacted because you are a student at Auburn University between the ages of 19 and 25 that meets our inclusion criteria. With your help it is hoped that the mechanism for tennis elbow (lateral epicondylitis) can be better understood. You were selected as a potential participant because of your age and the fact that your health condition permits you to perform the tests safely and successfully.

The purpose of this study is to assess the muscular activity of the Extensor Carpi Radialis (ECR) muscle during various common gripping conditions with and without a wrist device. Specifically the following questions will be assessed. (1) Does the activity of the muscle decrease when gripping in the presences of a wrist device? (2) How does the electrical activity of the muscle of various gripping tasks vary with and without a wrist device? The experiment will last approximately 45 minutes (this includes the time necessary for you to fill out the forms, and undergo all testing procedures). Your data will be collected using the following methods (by volunteering to participate in this study you agree to be tested using the following testing protocols):

**Isometric Grip of a Tennis Racket, Hammer, and Gallon of Water:** You will be asked to sit in our testing chair and grip a tennis racket with the amount of force one would use for normal activity. After a rest, you will do the same with a hammer. After another rest, you will do the same with a gallon of water.

**Isometric Grip of a Tennis Racket, Hammer, and Gallon of Water with Fixed Counter-moment:** You will be asked to sit in our testing chair and grip a tennis racket handle with the same magnitude you used previously, with an external fixed counter-moment. After a rest, you will do the same procedure with a hammer handle. After another rest, you will do the same with a gallon of water handle.

There are 3 main risks with regard to these testing protocols. First, the use of a razor for shaving EMG site placement areas can cause skin irritations. Second, the EMG pads may also cause skin irritation at the placement sites. If symptoms are very severe,

Participants Initials\_\_\_\_\_



APPENDIX C. MEDICAL SCREENING QUESTIONNAIRE

## Medical Screening Questionnaire

- | No  | Yes |  |
|-----|-----|--|
| ___ | ___ | 1. Do you currently have pain on the side of your elbow?   |
| ___ | ___ | 2. Have you previously had surgery on your dominant arm?   |
| ___ | ___ | 3. Have you ever been diagnosed with carpal tunnel syndrome?   |
| ___ | ___ | 4. Have you ever been diagnosed with Cervical Radicular Compression?   |
| ___ | ___ | 5. Have you ever been diagnosed with Posterior Interosseous-nerve Syndrome?  |
| ___ | ___ | 6. Do you currently have arthritis?  |
| ___ | ___ | 7. Do you currently have any active skin lesions?  |
| ___ | ___ | 8. Do you have any reason to believe that your participation in this investigation effort may put your health or well being at risk? |
| ___ | ___ | 9. Are you allergic to spray or sticky adhesive?   |

Signature of Subject \_\_\_\_\_