

**An Approach for Designing Product Lines Using Product Icon Analysis**

by

Si Luo

A thesis submitted to the Graduate Faculty of  
Auburn University  
in partial fulfillment of the  
requirements for the Degree of  
Master of Industrial Design

Auburn, Alabama  
December 16, 2017

Keywords: Product icon, Visual Design Elements,  
Product lines, Product design

Copyright 2017 by Si Luo

Approved by

Shea Tillman, Chair, Associate Professor of Industrial Design  
Shu-Wen Tzeng, Associate Professor of Industrial Design  
Carlton Lay, Assistant Professor of Industrial Design

## Abstract

With the increasing number of companies and brands around the world, the overload of product supply has forced companies to find new ways to differentiate. However, to create a recognizable and distinctive brand through product design is a challenge for companies and designers. Utilizing an existing product icon to expand product lines can be a remedy for this problem. By analyzing a product icon, distinctive visual design elements can be uncovered. In order to use these elements effectively in product design, this thesis will explore how to abstract visual design elements, and verify their priority from an existing product icon. Finally, it will illustrate an approach that helps designers or companies expand their product icon into product lines, consisting of several supporting checklists that will be developed in this thesis.

## Acknowledgments

I would like to express the deepest appreciation to my committee chair, associate professor Shea Tillman, for his academic instruction and encouragement. Without his valuable assistance, this work would not have been able to be completed. Also, thanks to associate professor Shu-Wen Tzeng and assistant professor Carlton Lay, for their guidance and inspiration.

I also want to thank the participants in my product icon survey, who have willingly shared their precious time and thoughts during the process of completing the survey online.

I would like to thank my parents and all my friends for always supporting me and encouraging me with their best wishes.

## Table of Contents

Abstract .....	ii
Acknowledgments.....	iii
List of Figures .....	viii
Chapter 1 Introduction .....	1
1.1 Problem Statement .....	1
1.2 Need for Study .....	2
1.3 Objectives of Study .....	3
1.4 Definition of Terms .....	3
1.5 Assumptions .....	4
1.6 Scope and Limits .....	4
1.7 Procedures and Methodology .....	5
1.8 Anticipated Outcome .....	5
Chapter 2 Literature Review .....	7
2.1 Introduction .....	7
2.2 Product Design Perceptions and Brand Categorization .....	7
2.2.1 Product Design Perception .....	8
2.2.2 Brand Categorization .....	9
2.3 Product Visual Design Elements .....	12

2.3.1 Explicit Design Elements.....	12
2.3.2 Implicit Design Elements.....	18
2.4 Conclusion .....	22
Chapter 3 Product Icon Survey .....	23
3.1 Introduction .....	23
3.2 The Design of the Survey .....	23
3.2.1 Participants .....	23
3.2.2 Method of Distributing the Survey .....	23
3.2.3 Research Questions .....	24
3.3 Data Collection .....	30
3.4 Product Icon Checklist .....	36
3.5 Conclusion .....	37
Chapter 4 Product Icon Case Studies .....	38
4.1 Introduction.....	38
4.2 Anglepoise .....	38
4.2.1 About Anglepoise Desk Lamp .....	38
4.2.2 Analysis of Product Line Expansion .....	40
4.3 Fiskars .....	44
4.3.1 About Fiskars Scissors .....	44
4.3.2 Analysis of Product Line Expansion .....	47
4.4 Bialetti .....	50

4.4.1 About Bialetti Moka Express.....	50
4.4.2 Analysis of Product Line Expansion .....	52
4.5 KitchenAid .....	56
4.5.1 About KitchenAid Stand Mixer .....	56
4.5.2 Analysis of Product Line Expansion .....	58
4.6 Conclusion .....	62
Chapter 5 An Approach for Designing Product Lines Using Product Icon Analysis.....	65
5.1 Introduction .....	65
5.2 The Approach and Procedure .....	65
5.3 Product Icon Checklist .....	68
5.4 Visual Design Elements Checklist .....	70
5.5 Significance of Explicit Design Elements .....	71
5.5.1 Product Category Checklist .....	72
5.5.2 Explicit Design Elements Survey .....	74
5.6 Product Line Expansion Approach Checklist .....	75
5.7 Conclusion .....	76
Chapter 6 The Application of the Approach .....	78
6.1 Introduction.....	78
6.2 Step 1: Product Icon Checklist.....	78
6.3 Step 2: Visual Design Elements Checklist.....	80
6.4 Step 3: Significance of Explicit Design Elements .....	81

6.5 Step 4: Design Products .....	83
6.6 Step 5: Finalize Product Lines .....	90
Chapter 7 Conclusion and Further Development .....	91
7.1 Conclusion .....	91
7.2 Further Development .....	92
References .....	93
Appendix A .....	99
Appendix B .....	119
Appendix C .....	122
Appendix D .....	124
Appendix E .....	126

## List of Figures

Figure 1 Framework for Product Design Information Processing (Kreuzbauer & Malter, 2007) .....	7
Figure 2 Bodum French Press (Amazon, 2005a).....	9
Figure 3 The KitchenAid Stand Mixer (Amazon, 2002) .....	10
Figure 4 Volvo Car Front (top: 2014, bottom: 2007) (Autoblog, n.d.a.; Autoblog, n.d.b.).....	11
Figure 5 Volvo Design Cues (Karjalainen, 2007) .....	13
Figure 6 The Frame of the Display Appearing in the 3310 (Left and Second Left Top) and A Number of Different Nokia Models (Karjalainen, 2003c) .....	14
Figure 7 Design Format Analysis (Warell, 2001) .....	15
Figure 8 The Key Elements Containing the Buick Brand of a Front View (McCormack, Cagan, & Vogel, 2004) .....	16
Figure 9 Copiers of Océ Technologies (Stompff, 2003).....	17
Figure 10 The <i>R-O-I</i> Framework for the Analysis of Brand References in Design (Karjalainen & Snelders, 2010) .....	20
Figure 11 The <i>R-O-I</i> Framework Applied to Volvo and Nokia Cases (Karjalainen & Snelders, 2010) .....	20
Figure 12 Heredity and Variation Model of Product Family Design DNA (Luo & Zhu, 2009) .... .....	21



Figure 13 Question 1: What is Your Primary Area of Expertise? .....	24
Figure 14 Question 2: Years of Experience. ....	25
Figure 15 Question 3: In Your Opinion, What Most Establishes a Product as an Icon? .....	27
Figure 16 Question 4: Choose Three Products You Consider the Most Iconic. ....	28
Figure 17 An Example of Question 5: What Makes This Product Immediately Identifiable? ..	29
Figure 18 Data of Question 1: What is Your Primary Area of Expertise? .....	30
Figure 19 Data of Question 2: Years of Experience .....	31
Figure 20 Data of Question 3: What Most Establishes a Product as an Icon? .....	32
Figure 21 The Significance of Factors.....	33
Figure 22 Data of Question 4: Choose Three Products You Consider the Most Iconic .....	34
Figure 23 Sum Total Data Collection of Question 5 .....	35
Figure 24 Product Icon Checklist .....	36
Figure 25 Anglepoise Type 75 Desk Lamp (Anglepoise. n.d.c) .....	38
Figure 26 Checklist – Anglepoise Desk Lamp .....	39
Figure 27 Timeline of Anglepoise Desk Lamp Development History (Part 1) (Anglepoise. n.d.a) .....	40
Figure 28 Timeline of Anglepoise Desk Lamp Development History (Part 2) (Anglepoise, n.d.d; Laban, 2008) .....	41
Figure 29 Product Lines of Anglepoise (Anglepoise, n.d.d) .....	42
Figure 30 An Example of Different Anglepoise Lamps Types and Dimensions .....	42
Figure 31 The Original Orange-handled Scissors from Fiskars (Fiskars, n.d.b) .....	44

Figure 32 Fiskars Scissors from Two Centuries (Fiskars, n.d.a).....	45
Figure 33 Checklist – Fiskars Scissors .....	45
Figure 34 Fiskars Scissors 1967-2007 (Fiskars, n.d.a) .....	47
Figure 35 Product Lines of Fiskars (Fiskars, n.d.c) .....	48
Figure 36 Tools Design of Fiskars (Fiskars, n.d.d).....	49
Figure 37 Bialetti Moka Express Coffee Maker (Bialetti, n.d.b).....	50
Figure 38 Checklist – Bialetti Moka Express Coffee Maker .....	51
Figure 39 The First Moka and The First Design Revision (Bialetti, n.d.a; First Versions, n.d.) .....	52
Figure 40 Product Lines of Bialetti (Bialetti, n.d.c) .....	53
Figure 41 Moka and Coffee Makers of Bialetti (Bialetti, n.d.c).....	54
Figure 42 Espresso Machines of Bialetti (Bialetti, n.d.c).....	55
Figure 43 KitchenAid Artisan® Design Series 5 Quart Tilt-Head Stand Mixer (KitchenAid, n.d.a) .....	56
Figure 44 Checklist – KitchenAid Stand Mixer .....	56
Figure 45 Development Timeline of KitchenAid Stand Mixer (Maker Inc, 2014).....	57
Figure 46 Product Lines of KitchenAid (KitchenAid, n.d.b) .....	58
Figure 47 Explicit Design Elements of KitchenAid (KitchenAid, n.d.a).....	58
Figure 48 Countertop Appliances of KitchenAid (KitchenAid, n.d.b).....	59
Figure 49 Kitchenware of KitchenAid (KitchenAid, n.d.b) .....	60
Figure 50 Major Appliances of KitchenAid (KitchenAid, n.d.b; KitchenAid, 2015) .....	61

Figure 51 Design Approaches Summary .....	62
Figure 52 Western Electric Model 500 Telephone (Nbhdtestblog, 2012).....	63
Figure 53 Color Palette of Western Electric Model 500 telephone (Beatrice Companies Inc, n.d.) .....	63
Figure 54 An Approach for Designing Product Lines Using Product Icon Analysis .....	66
Figure 55 Product Icon Checklist .....	68
Figure 56 Visual Design Elements Checklist .....	70
Figure 57 Product Category Checklist .....	72
Figure 58 Explicit Design Elements Survey .....	74
Figure 59 Product Line Expansion Approach Checklist .....	75
Figure 60 Swingline 747 Business Stapler (Amazon, 2005b) .....	78
Figure 61 Product Icon Checklist for Swingline 747 Business Stapler .....	79
Figure 62 Visual Design Elements Related to Swingline 747 Business Stapler .....	80
Figure 63 Explicit Design Elements of Swingline 747 Business Stapler .....	80
Figure 64 Checked the Priority of Explicit Design Elements in Product Category Checklist ...	81
Figure 65 The Priority of Explicit Design Elements of Swingline 747 Business Stapler .....	82
Figure 66 Checked the Product Line Expanding Approach Checklist .....	83
Figure 67 Idea Collection .....	84
Figure 68 Swingline Manual Pencil Sharpener Concept 1 .....	85
Figure 69 Swingline Manual Pencil Sharpener Concept 2 .....	85
Figure 70 Swingline Hand Held Pencil Sharpener Concept 1 .....	86

Figure 71 Swingline Hand Held Pencil Sharpener Concept 2 .....	86
Figure 72 Swingline Manual Pencil Sharpener .....	87
Figure 73 Swingline Manual Pencil Sharpener .....	88
Figure 74 Swingline Hand Held Pencil Sharpener .....	89
Figure 75 Swingline 747 Business Stapler (Amazon, 2005b) .....	90
Figure 76 Swingline Pencil Sharpener Product Line .....	90

## **Chapter 1**

### **Introduction**

#### **1.1 Problem Statement**

Today, the market is filled with all kinds of products that are similar in form and similar in quality. This means that brands need to differentiate to stand out from the crowd. Within varieties of product categories, one of the central competitive factors is the visual recognition of brands and products (Karjalainen, 2007). Looking into product portfolios from brands with recognizable designs such as Volvo, BMW, and Nokia, high product quality and specific visual design elements play a very important role. These brands use specific visual design elements consistently through their product portfolio. This design consistency helps them clearly differentiate from their competitors and strengthen their position in the market. Therefore, product differentiation is an important factor to make these brands successful.

In order to differentiate, finding specific visual design elements that are consistently used in product lines for brands is significant. With the right visual design elements, the identity and brand message become evident to consumers in current and future product designs in a systematic way (Beyond Design Inc., 2012). Designers that can be called designated ‘form-givers’ are expected to understand the working process and use knowledge of design elements to give intentional style to the products they design (Chen & Owen, 1997).

However, to create a recognizable and distinctive brand through product design is a challenge for companies and designers. What kinds of visual design elements of products are specific to a product? Is there a prioritization of these visual design elements? Utilizing an existing product icon that has not been expanded upon, in order to abstract visual design elements from the icon

could be an effective way to help with this problem. The aim of this thesis is to find answers about how to abstract visual design elements, verify their priority from a product icon, and then transform and expand this icon into product lines.

## **1.2 Need for Study**

In today's market, brand-specific design language is of vital importance for a company and can even influence a company's position and reputation (Karjalainen, 2003a). Meanwhile, factors of the physical appearance of products often contribute to the meaning of a brand for consumers (Creusen & Schoormans, 2005). This means that strong, coherent, and specific visual design elements of products can help companies stand out from the competitive product market. Specific visual design elements of products also play a very important role in making product recognizable. Therefore, specific visual design elements are also essential for product icons, even though they already have been tested in the market for a long time.

In addition, the significance of visual design elements of different product categories can be varied. For example, the priority of visual design elements for home appliances may differ from office supplies. The significance of product visual design elements should be clear and definite while designing products. However, this issue is often not studied or developed. To address this gap of knowledge, the study of the priority of product visual design elements is needed.

To use visual design elements of product icons efficiently not only makes product designs with a consistent appearance, but also may help companies and brands differentiate in the market.

### 1.3 Objectives of Study

This thesis presents an approach for helping companies determine if they already have a product icon, and develops an approach for expanding product lines by utilizing visual design elements of their product icons. The following are the objectives of this thesis.

- Study visual design elements of different products.
- Understand how to define, from a product icon, and establish the priority of explicit design elements in different product categories.
- Study how companies with an existing product icon expand their product lines.
- Develop an approach that helps to expand a product icon into product lines.

### 1.4 Definition of Terms

- **Design DNA:** To provide an effective method of industrial design, which helps to build a unique brand by giving distinctive form and special style to the product (Lu, Tang, & Xue, 2010).
- **Product Family:** A group of products that can share common characteristics and components, and can meet the needs of a series of market environments (Zhu, Luo, Ying, & He, 2010).
- **Visual brand language:** “Visual brand language is a core part of product design where the abstract and experiential part of a brand is cohesively communicated through physical elements” (Beyond Design Inc., 2012).

## **1.5 Assumptions**

This study involves several assumptions, detailed as follows. First, it is assumed that all product icons contain specific visual design elements. Second, it is assumed that designers are able to transform a product icon into product lines by utilizing specific product visual design elements.

## **1.6 Scope and Limits**

### **Scope of Study:**

This study focuses on how companies transform their existing product icons into product lines by utilizing visual design elements of product icons. This thesis will propose an approach for companies and designers who work in companies and individual designers. This study will cover the following:

- The study focuses on the visual design elements of product icon, but not information from other senses (e.g., auditory, tactile, olfactory) that may affect product design results.
- This research focuses on helping companies and designers to create product lines from a product icon. However, the approach developed in this study is not limited to being used by designers, so others could use the same approach in product design and development decisions, such as product managers and product engineers.
- The analysis and research will only explore the products that have been tested through the consumer market for an extended period of time.



## **Limits of Study:**

There are several limits in this study as follows:

- The product selection of this study does not cover every product genre.
- Because the future of certain products from each company cannot be anticipated, this study will only analyze products lines from the original design series to the latest series.
- Because product development cannot be anticipated, the approach is limited by time constraints. Further research will need to be done in the future.

## **1.7 Procedures and Methodology**

Plan of procedures and methodology:

- Study design elements of general products.
- Study how to define a product icon and the priority of explicit design elements.
- Analyze cases to study how companies with an existing product icon expand their lines.
- Develop an approach to help companies expand product lines.
- Examine the approach through analyzing a product icon and expanding into product lines.
- Evaluate the effectiveness of the approach.

## **1.8 Anticipated Outcome**

The anticipated outcome of this study is a design approach that will help designers and companies verify product icons they have, and utilize the specific visual design elements of these

product icons to expand product lines for continued success in the market. It will also help companies remove obstacles while expanding product icons into product lines in order to increase market share.

## Chapter 2

### Literature Review

#### 2.1 Introduction

In order to develop an approach for expanding a product icon into a product line, the study should begin with understanding a product, and two aspects need to be analyzed. First of all, the designer must understand product design perception as a process of how consumers gain information through their visual perception. This process can influence consumers' categorization of brands. Second, the visual design elements of products must be analyzed. Design elements constitute important components of the brand concept, and specific design elements play a key role in identifying a product as a member of a brand category (Kreuzbauer & Malter, 2007). Therefore, discovering what kind of design elements that general products contain and that affect consumers' perceptions of brands is obviously necessary.

#### 2.2 Product Design Perceptions and Brand Categorization

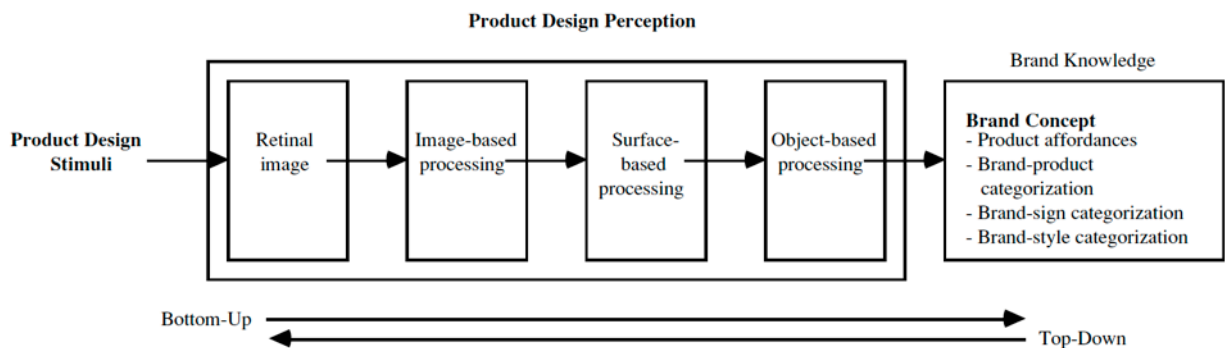

Figure 1, Framework for Product Design Information Processing (Kreuzbauer & Malter, 2007)

In 2007, Kreuzbauer and Malter proposed a theoretical framework for product design information processing (Figure 1). This framework indicates how information is picked up from

product design elements, and that product design perception affects consumers' categorization of brands in several ways.

### **2.2.1 Product Design Perception**

There is a perception process to understand a product for consumers. "All perceivers share a common visual system" (Leder, Carbon, & Kreuzbauer, 2007, p.5). According to the framework (Figure 1), a consumer's perception of a product passes through four stages before it becomes categorized. These stages include the retinal image, image-based processing, surface-based processing, and object-based processing. The first impression of a visual product design stimulates a two-dimensional retinal image that is projected to the viewpoint of the observer's eyes (Kreuzbauer & Malter, 2007). After that, the retinal image is further processed to the second stage that is also called the image-based stage. The aim of this stage is to extract product design elements such as lines and edges of the stimulus (Leder, Carbon, & Kreuzbauer, 2007). General surface and spatial information including surface attributes such as color, shininess, hue, texture are detected in the third surface-based stage (Leder, Carbon, & Kreuzbauer, 2007). The final object-based stage consists of three-dimensional processing. Observers are able to make clear predictions and assumptions information about unseen surfaces or parts of surfaces of objects by perceiving all the visible surfaces (Kreuzbauer & Malter, 2007). For example, an observer can make predictions about the possible appearance and properties of the back of a TV by perceiving the surfaces from the front viewpoint of the TV.

### **2.2.2 Brand Categorization**

The forementioned levels of product design perception are able to influence brand knowledge structures in the following four ways.

#### **Product Affordances**



Figure 2, Bodum French Press (Amazon, 2005a)

Products can communicate functional properties to people by visual characteristics that may be identified in the surface-based and object-based stages, such as shapes, features, material and size (Leder, Carbon, & Kreuzbauer, 2007). People may acquire information about the main functions through perceiving visual characteristics of products before use. Taking a coffee maker as an example (Figure 2), the handle of the coffee maker communicates “grasping” information to people, as well as its material difference communicating its insulating quality. Hence, people are likely to hold the handle while using the coffee maker in order to insulate their hands from heat.

#### **Brand-Product Categorization**

Brand-product categorization expresses the relationship between products and brand that incorporate brand-level design information and generic product category information (Kreuzbauer & Malter, 2007). For example, the Audi brand concept consists of brand design

knowledge about Audi car models as well as generic product category knowledge that is the general concept of a car.

### **Brand-Sign Categorization**

Products that are branded also communicate information about characteristics of a particular brand beyond generic product information (Kreuzbauer & Malter, 2007). For example, the distinctive lights design on the front and back of the Audi car. Brand-sign categorization can be further divided into brand-symbolic categorization processes and brand-iconic categorization processes (Leder, Carbon, & Kreuzbauer, 2007). Except for product design elements within the brand concept, the brand-symbolic categorization processes occurs when those elements do not involve to any major external knowledge units (Kreuzbauer & Malter, 2007). For instance, the Audi logo represents its company, but does not convey any intrinsic meaning by itself. However, the brand-iconic categorization occurs when product design elements refer to non-brand specific concepts; for example, a BMW car resembles a predator when looking through its typical front perspective (Kreuzbauer & Malter, 2007).



Figure 3, The KitchenAid Stand Mixer (Amazon, 2002)



Figure 4, Volvo Car Front (top: 2014, bottom: 2007) (Autoblog, n.d.a.; Autoblog, n.d.b.)

Brand-sign categorization frequently occurs during the surface-based processing, because a product's surface will be embedded within the brand concept when consumer perceives it, which then induces brand-sign categorization processes (Leder, Carbon, & Kreuzbauer, 2007). For example, the surface of a classic KitchenAid stand mixer is smooth with large radii (Figure 3). These typical surface designs become embedded within the part of KitchenAid brand concept and determine a brand-iconic categorization process with associations such as clean and organic. In addition to the surface, the object-based processing stage also can lead to brand-sign categorization, which is relevant to product and brand line extension strategies (Kreuzbauer & Malter, 2007). For instance, when Volvo introduced the new S60 model for the target market, it partially resembled the old Volvo S60 model (Figure 4). This new model had to contain enough important design elements from the previous model to continue the brand recognition. "Thus, the brand familiarity of product design (shape) elements is important in the case of product line extension" (Kreuzbauer & Malter, 2007, p.243).

## **Brand-Style Categorization**

Various combinations of surface- and object-based perception processes can lead to brand-style categorization (Leder, Carbon, & Kreuzbauer, 2007). For example, some design attributes that include complex forms, fantasy, and allusions to historic styles constitute the “post-modern” style concept. Attaching these design attributes to a branded product, such as a Swatch watch, produces a conceptual combination of a “post-modern Swatch” watch so the consumer will consider the Swatch a post-modern brand.

In summary, the product design perception and brand knowledge model is a theoretical framework about how people gain product design information after being stimulated by a product design. Products are able to communicate their function properties, product category information, specific design elements, and style of a brand to people. The brand-sign categorization that people gain from the specific design elements of products through the object-based processing stage is related to the study of this thesis. The specific design elements of products are important for brand recognition. Thus, the following sections will discuss design elements of different products.

## **2.3 Product Visual Design Elements**

Visual recognition of a product can be reflected through two different types of visual design elements including explicit design elements and implicit design elements (Karjalainen, 2004).

### **2.3.1 Explicit Design Elements**

Product visual design elements may be identified by various “stylistic attributes” including form elements, joining relationships, detail treatments, materials, color treatments, and textures



(Chen & Owen, 1997). Explicit design elements are specific design elements that can be consistently used across the product portfolio including specific forms, colors, and materials (Karjalainen & Warell, 2005). To use explicit design elements is a direct way to maintain visual consistency over the product portfolio. There are several studies that discuss the explicit design elements.

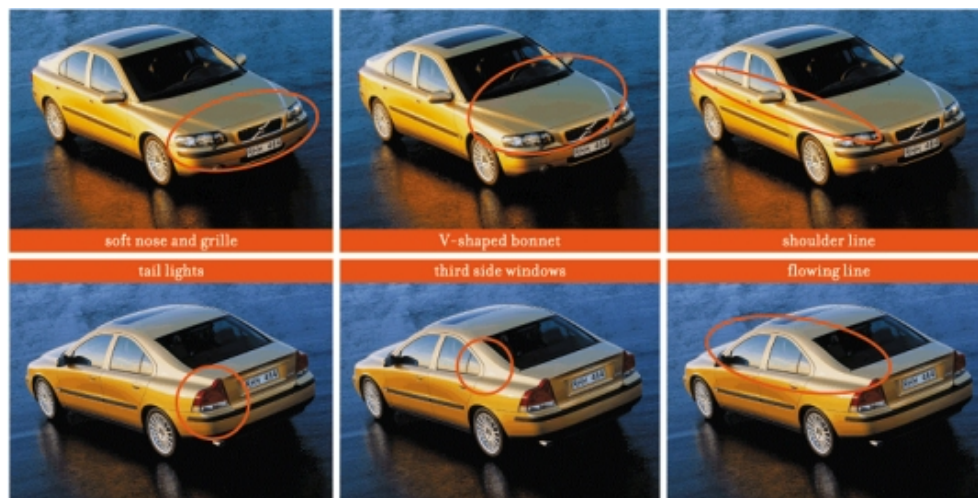

Figure 5, Volvo Design Cues (Karjalainen, 2007)

Karjalainen (2002, 2003a, 2003c, 2007) and Karjalainen & Snelders (2010) have done in-depth case study on Volvo cars to explore product-explicit references, and indicated that Volvo used consistent explicit design elements over their entire product portfolio. These explicit design elements included a soft nose and diagonal Volvo logo, the V-shaped bonnet, the “shoulder line”, the boot with its distinctively carved backlight, the third side windows, and the strong characteristic lines flowing from the front to the rear (Figure 5). Volvo cars have continued using these clear specific forms, including these form elements and detail treatments in all their recent models to strengthen the brand recognition.



Figure 6, The Frame of the Display Appearing in the 3310 (Left and Second Left Top) and A Number of Different Nokia Models (Karjalainen, 2003c)

In addition to Volvo, Nokia is another brand that Karjalainen (2003b, 2003c) and Karjalainen & Snelders (2010) studied. There were many recurring attributes across mobile phone designs, despite the visual flexibility over the entire Nokia product category (Karjalainen & Snelders, 2010). The design elements on the functionality and layout of the keypad, including the frame of the display (the curved classical human-like U and Y shape silhouette), “the face”, and the four clearly visible horizontal lines of buttons, are considered “icons” of Nokia (Figure 6). These could be seen as detail treatments of a product design.

In a student design project that focuses on studying how visual product features could be used to create brand recognition, Karjalainen and Warell (2005) required students to visually scan multiple images and then select the most characteristic visual design elements of products studied in the first step. Students had to analyze visual characteristics on holistic and atomistic levels of the product form, including gestalt elements, characteristic elements, and explicit signifiers. Gestalt elements included general shape characteristics that can represent the basic product sign of products, such as silhouette outlines, stance, and proportions. Characteristic

elements that were found over product portfolios included character lines, curve elements, shape characteristics and other specific elements. These specific form elements and detail treatments could be considered visually characteristic for the brand. Explicit signifiers could be used to identify the brand, including repeated design elements used as part of the visual heritage.

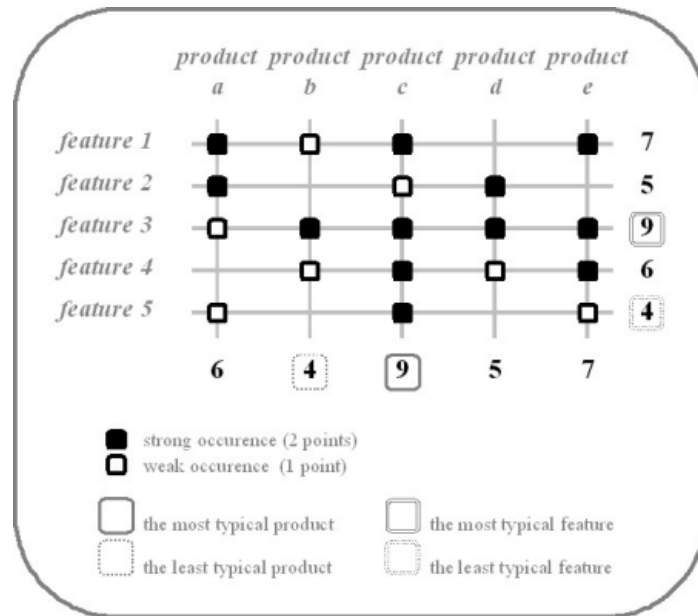

Figure 7, Design Format Analysis (Warell, 2001)

Moreover, in another design project that aided students understanding the theme of design for visual brand recognition, the approach of Design Format Analysis (DFA), developed by Warell (2001), was used to analyze the visual design elements and visual design history of the brands (Figure 7). To select design features is the first task. Features could be subjectively selected, or what the company itself has defined as the brand's visual design elements. The next task is to examine whether the chosen products contain these features or not. In the process of using the DFA method, various features can be analyzed, such as shapes, materials, and colors (Karjalainen, 2007). Shape and form features were most commonly used in this student design project.

The diagram (Figure 7) shows a systematic way in how to use the DFA method. According to the degree of importance for visual brand recognition, design features and products can be ranked (Karjalainen, 2007). A black dot means the strong occurrence of a specific feature; for example, product “b” incorporates feature “3”, which indicates that feature “3” appears the most typical of product “b”. In contrast, a white dot means the weak occurrence of a specific feature; for example, product “e” incorporates feature “5”, which indicates that feature “5” appears not so typical on product “e”. Therefore, within this analysis in figure 6, product “c” is the most typical product, but product “b” is the least typical product; feature “3” is the most typical feature, but feature “5” is the least typical feature. Using this DFA method to analyze the explicit design elements is useful for constructing visual recognition (Karjalainen, 2007).

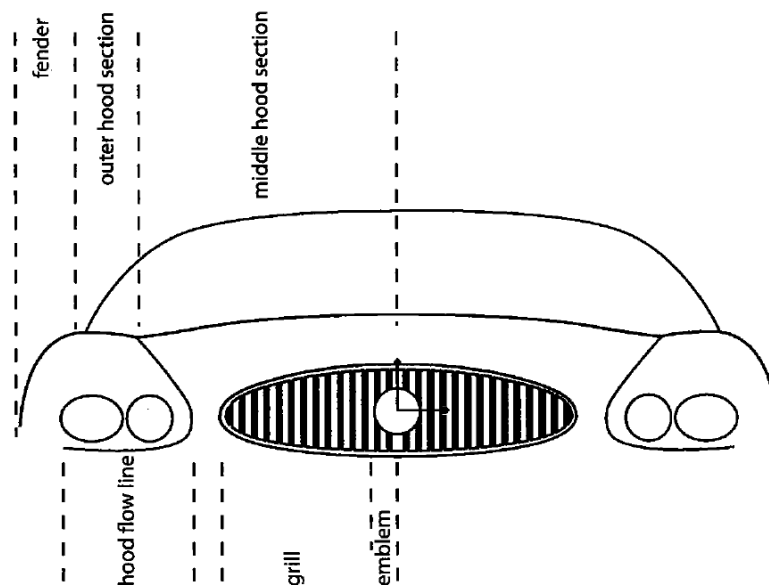

Figure 8, The Key Elements Containing the Buick Brand of a Front View (McCormack, Cagan, & Vogel, 2004)

McCormack, Cagan, and Vogel (2004) have done a study that presents shape grammars as a method to help to build or to maintain a strong brand by encoding the key elements of a brand into a repeatable language. “A shape grammar is a set of rules, based on the shape that is used to

generate designs through a series of rule applications beginning with an initial shape” (McCormack, Cagan, & Vogel, 2004, p.3). The research investigates the history and the evolution of front view design of Buick vehicles. Finally, the study develops 63 shape rules that can be used to create a new Buick vehicle. In this study, the key Buick vehicle visual design elements selected based on a brand hierarchy could be divided into three levels. The grill is the primary brand element. The secondary brand elements include the hood flow lines, the outer hood, and the fenders. The middle hood section adjacent to the curves that define the outer hood section is the tertiary element. These are key elements of a front view of a Buick vehicle (Figure 8).



Figure 9, Copiers of Océ Technologies (Stompff, 2003)

Stompff (2003) has done a case study about copiers from Océ Technologies to explore how brand values can be translated into product design. The Océ’s copiers have several examples of brand DNA, including the repetitive proportions from the smallest part to the whole product, the

symmetrical inclination that could be immediately recognized among different product, and colors of the Graphical User Interface that create a consistent product feeling (Figure 9).

Based on the literature above, explicit design elements that those classic products use consistently through their product lines include form elements, detail treatments, materials, and colors.

### **2.3.2 Implicit Design Elements**

Aside from the explicit design elements, implicit design elements that are not fully distinguishable or developed and are not evident also can create identification and create brand-specific associations (Karjalainen & Warell, 2005). Several publications discuss implicit design elements.

In a design project, the student exercises demonstrate that in order to have a successful development of visual brand recognition, despite the explicit design elements that are rather straightforward, the implicit references in product design are more important (Karjalainen, 2007). Karjalainen (2001) has also explored metaphor as a tool for brand/product identity analysis in the Design and Product/Brand Identity Workshop (DIW) course. There are several ways to characterize products and their designs (such as representational adjectives or metaphors), for example a BMW being more “shark-like” than an Audi. In this course, students were asked to analyze brand/product identity elements including core values, attributes, and characteristics (including visual references) for the selected product/brand. This is a very important part in the process of brand identification through metaphor. A prerequisite for effective identity management is to identify core values that may help to discover the elements that make the brand and product distinctive and desirable.

In addition to explicit design elements, product design seems to present symbolic references on a more invisible level, such as implicit design elements (Karjalainen, 2002). The case study of Volvo, Nokia, and Océ Technologies from Karjalainen (2003c) and Stompff (2003) also analyzed implicit design elements. In addition to those explicit design elements appearing on Volvo cars that are mentioned earlier, the Volvo still has a distinctive identity for decades ---- safety and family values. With strong visual design elements, a more emotional appearance, a strong link to the brand heritage, and core identity attributes of the Volvo brand, the new design language appearing on S80 model was a strategic success (Karjalainen, 2003c). The core value of Nokia was ease of use that guided the design principles ---- personalization and usability. The brand value appeared in every new Nokia product and incorporated characteristics such as comfort, balance, and pleasure of use. The copier design of Océ Technologies is often described as “calm, restrained, tranquil, balanced”. Designers have to become the brand by understanding the position, and breathing and absorbing the culture of the company or brand (Stompff, 2003).

In summary, implicit design elements for a product design include brand values, brand heritage, and brand attributes. These elements are always represented through whole product lines.

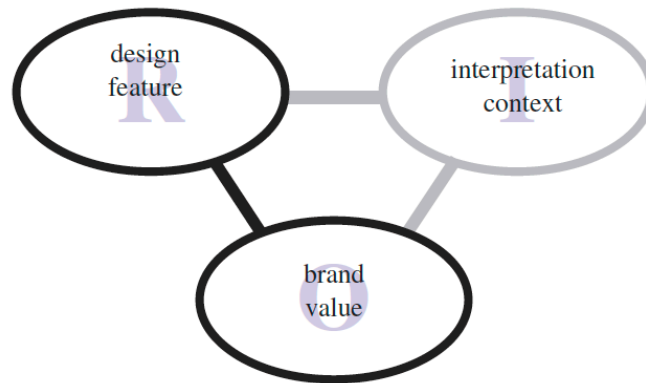

Figure 10, The *R-O-I* Framework for the Analysis of Brand References in Design (Karjalainen & Snelders, 2010)

There is a framework that Karjalainen & Snelders (2010) used to analyze how companies communicate their brand values to target customers (Figure 10). In this framework, *R* is taken as a design feature such as form, shape, and color, while *O* is related to a brand value that has a reference relationship with the design elements, and *I* means interpretation context that involves the interpreter's subjective realm and the environment in which the interpretation is made.

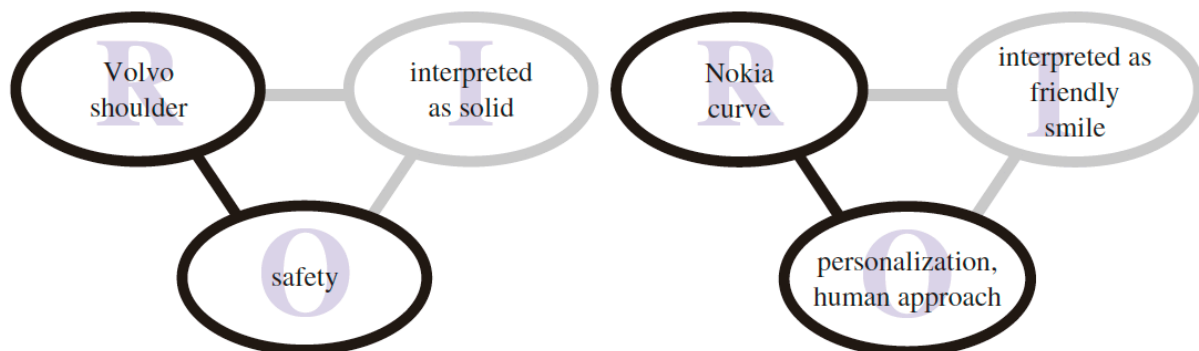

Figure 11, The *R-O-I* Framework Applied to Volvo and Nokia Cases (Karjalainen & Snelders, 2010)

Karjalainen & Snelders (2010) has taken Volvo and Nokia cases as examples (Figure 11). The specific shoulder feature of Volvo cars may be interpreted as solid, which refers to the brand



value of safety. The Nokia curve is related to the value of personalization and human approach by being interpreted as a friendly smile.

Implicit product elements express specific brand values. Meanwhile, the explicit design elements still play a very important role in this process. They can help to present specific implicit design elements of products. Consumers' interpretation is a connection that helps design features represent specific implicit elements of product design.

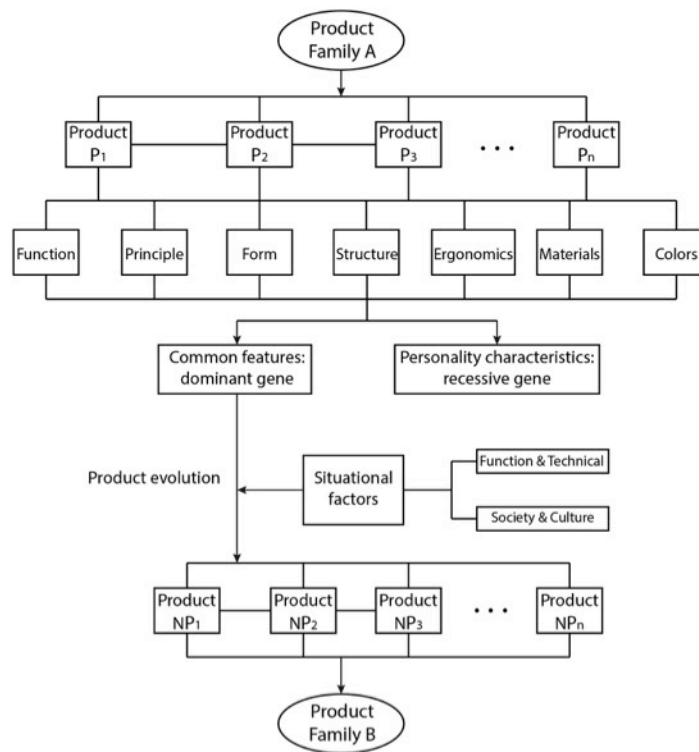

Figure 12, Heredity and Variation Model of Product Family Design DNA (Luo & Zhu, 2009)

An existing literature shows a heredity and variation model of product family design DNA that is a relationship from one product family to another (Figure 12). This is an ontology-based model that is used to design products efficiently, which is controlled by several pieces of mathematics defining function. However, it is not detailed enough, and some content of the

ontology-based model is not very convincing. Therefore, inspired by its structure, a design approach that is based on the study of this thesis will be put forward.

## **2.4 Conclusion**

In summary, the process by which that information of a product design is picked up will affect people's perception of brand knowledge. Specific design elements that are important for brand recognition help people gain information about brand-sign categorization. Explicit design elements that represent design intentions can be immediately perceived and recognized, while implicit elements are not so readily distinguished in the product but they can still "make sense" when they are applied to a design (Karjalainen & Snelders, 2010). Thus, explicit design elements and implicit design elements are very important for a product design. In addition, explicit design elements can help communicate implicit attribute. Explicit design elements and implicit design elements are linked.

The goal of this thesis is to develop a design approach for helping a company to create a recognizable and distinctive brand and differentiate in the market. To utilize an existing product icon that has not been expanded upon to expand product lines could be an effective way to help with this issue. Hence, to verify whether a company has a product icon or not is very important. A survey to study the definition of a product icon will be demonstrated in the following chapter. Product visual design elements are important for a product. The survey will also study the priority of explicit design elements of products due to implicit design elements that are always carried through the entire product portfolio.

## **Chapter 3**

### **Product Icon Survey**

#### **3.1 Introduction**

In order to help identify a product as an icon and study the priority of explicit design elements, the product icon should first be defined and a priority assigned to explicit design elements an iconic product should have. Collecting opinions from different designers of various design experience areas are needed. As part of this research, an online survey has been designed, and will serve as a tool to collect a variety of viewpoints. Collection and analysis of survey data will result in a product icon checklist that will be used to better select cases to study.

#### **3.2 The Design of the Survey**

##### **3.2.1 Participants**

The participants are designers from diverse experience areas, such as product designers, graphic designers, exhibit/event designers, etc. Selecting designers as the participants of this survey is important, as the opinions of trained designers is more beneficial. Whether designers graduated from college recently or already had extensive design experience is taken into account in this survey.

##### **3.2.2 Method of Distributing the Survey**

This survey will be distributed via the Internet to access professional designers. Sending emails and posting on social media are the primary methods for issuing the survey. Invitation letters and survey links will be sent by email to some designers. Invitation messages and survey

links will be posted on social media, which may receive responses that is spontaneous and could get a relatively wide range of samples. In order to ensure data collection is integrated and effective, responses with complete answers count as valid.

### 3.2.3 Research Questions

This survey has been designed as three sections, with five questions in total within these sections (see Appendix A). Respondents should take about 5-7 minutes to complete the survey.

The first section is to collect basic information from respondents, including their primary area of expertise, and years of experience. These required questions the single choice answers.

What is your primary area of expertise?

- Product designer
- Graphic designer
- Exhibit/Event designer
- UX/UI designer
- Design engineer
- Marketing/Brand manager
- Architect
- Interior designer
- Other

Figure 13, Question 1: What is Your Primary Area of Expertise?

Question 1: What is your primary area of expertise?

This is a question to make sure that people who are taking this survey are experienced designers. There are eight options for respondents to choose, including product designers, graphic designers, exhibit/event designers, UX/UI designers, design engineers, marketing/brand managers, architects, interior designers. Designers with different design experience backgrounds are necessary for this survey because a variety of designers have a different perspective of

thoughts in design. However, it does not cover all kinds of expertise areas among these options. Therefore, the other option is essential, which means targeted designers of this survey are not only limited to these eight types and all types are welcome.

**Years of experience.**

- 1-5
- 6-10
- 11-15
- 16-30
- More than 30

Figure 14, Question 2: Years of Experience.

**Question 2: Years of experience.**

After ensuring respondents are designers, there is a question about years of design experience. Years of experience have been divided into five periods: 1-5 years, 6-10 years, 10-15 years, 16-30 years, and more than 30 years. The reason for putting forward this question is that designers with different years of experience may have different opinions of design. This difference may influence the answers of following questions.

The second section is to investigate respondents' opinions about the product icon and iconic products through their design experience. There is one question asking the respondents' perspective about what most establishes a product as an icon. Respondents have to scale the importance of each factor for establishing a product as an icon on the list. The list of factors used to define iconic design is found from website [www.technologystudent.com](http://www.technologystudent.com) shown as below:

1. A design that sets a benchmark for others to follow.

2. A ground breaking design, in terms of its technology or manufacturing techniques used during its production.
3. A design that improves on the past.
4. A design that sets new standards in terms of quality, functions/features or style.
5. A design that stands the test of time, remaining popular despite the passing of years.
6. A design that stays in the memory of those who see/use it.
7. A design that is often recognized immediately by consumers.
8. A design that inspires other designers.
9. Sets a trend.
10. A design that is innovative.
11. A design that is aesthetically pleasing.
12. A design that is often emulated/copied by other designers.
13. A design that has its place in history, or even helps change history.

The source of this list may lack credibility because it does not belong to a published article or a journal. Despite that, the contents of this list of describing a product as an icon still offer an exhaustive set of criteria deemed appropriate by the investigator. However, a prioritized list to define a product icon is not provided. Therefore, this question is also intended for making the list more credible.

In your opinion, what most establishes a product as an icon?

	Least important	Slightly important	Neutral	Very important	Most important
Sets a benchmark for others to follow.	<input type="radio"/>	<input type="radio"/>	<input type="radio"/>	<input type="radio"/>	<input type="radio"/>
Is a ground breaking design.	<input type="radio"/>	<input type="radio"/>	<input type="radio"/>	<input type="radio"/>	<input type="radio"/>
Improves on the past.	<input type="radio"/>	<input type="radio"/>	<input type="radio"/>	<input type="radio"/>	<input type="radio"/>
Sets new standards.	<input type="radio"/>	<input type="radio"/>	<input type="radio"/>	<input type="radio"/>	<input type="radio"/>
Stands the test of time.	<input type="radio"/>	<input type="radio"/>	<input type="radio"/>	<input type="radio"/>	<input type="radio"/>
Stays in the memory of who see/use it.	<input type="radio"/>	<input type="radio"/>	<input type="radio"/>	<input type="radio"/>	<input type="radio"/>
Is often recognized immediately by consumers.	<input type="radio"/>	<input type="radio"/>	<input type="radio"/>	<input type="radio"/>	<input type="radio"/>
Inspires other designers.	<input type="radio"/>	<input type="radio"/>	<input type="radio"/>	<input type="radio"/>	<input type="radio"/>
Sets a trend.	<input type="radio"/>	<input type="radio"/>	<input type="radio"/>	<input type="radio"/>	<input type="radio"/>
Is innovative.	<input type="radio"/>	<input type="radio"/>	<input type="radio"/>	<input type="radio"/>	<input type="radio"/>
Is aesthetically pleasing.	<input type="radio"/>	<input type="radio"/>	<input type="radio"/>	<input type="radio"/>	<input type="radio"/>
Is often emulated/copied by other designers.	<input type="radio"/>	<input type="radio"/>	<input type="radio"/>	<input type="radio"/>	<input type="radio"/>
Has its place in history, or even helps change history.	<input type="radio"/>	<input type="radio"/>	<input type="radio"/>	<input type="radio"/>	<input type="radio"/>
Enter another option <input type="text"/>	<input type="radio"/>	<input type="radio"/>	<input type="radio"/>	<input type="radio"/>	<input type="radio"/>
Enter another option <input type="text"/>	<input type="radio"/>	<input type="radio"/>	<input type="radio"/>	<input type="radio"/>	<input type="radio"/>

Figure 15, Question 3: In Your Opinion, What Most Establishes a Product as an Icon?

Question 3: In your opinion, what most establishes a product as an icon?

In this question, respondents need to scale the importance of thirteen factors that affect establishing a product as an icon. For respondents' convenience, the description of each factor has been simplified as shown in Figure 15. There are five levels of importance for respondents to scale, including least important, slightly important, neutral, very important, and most important. Respondents should scale the importance according to their professional design opinion.

In order to ensure equity and quality of the survey, the order of the list will show randomly, which means the list will display differently in each survey, but the total number of options is the same. At the end of this question, respondents could enter another option by typing in the blank,

and then scale the importance. This should lead to diverse opinions from respondents.

There are two questions in the third section. These two questions aim to study the priority of product visual design elements for different product categories. In this section, one question asks respondents to choose three products they consider the most iconic. This question contains fifteen different kinds of iconic product images that are provided for respondents to choose. Respondents make the choice based on their perceptions and design experience. Finally, respondents go to the last question of the survey, which asks them why they choose these three products by scaling the importance of form, materials, colors and overall appearance.

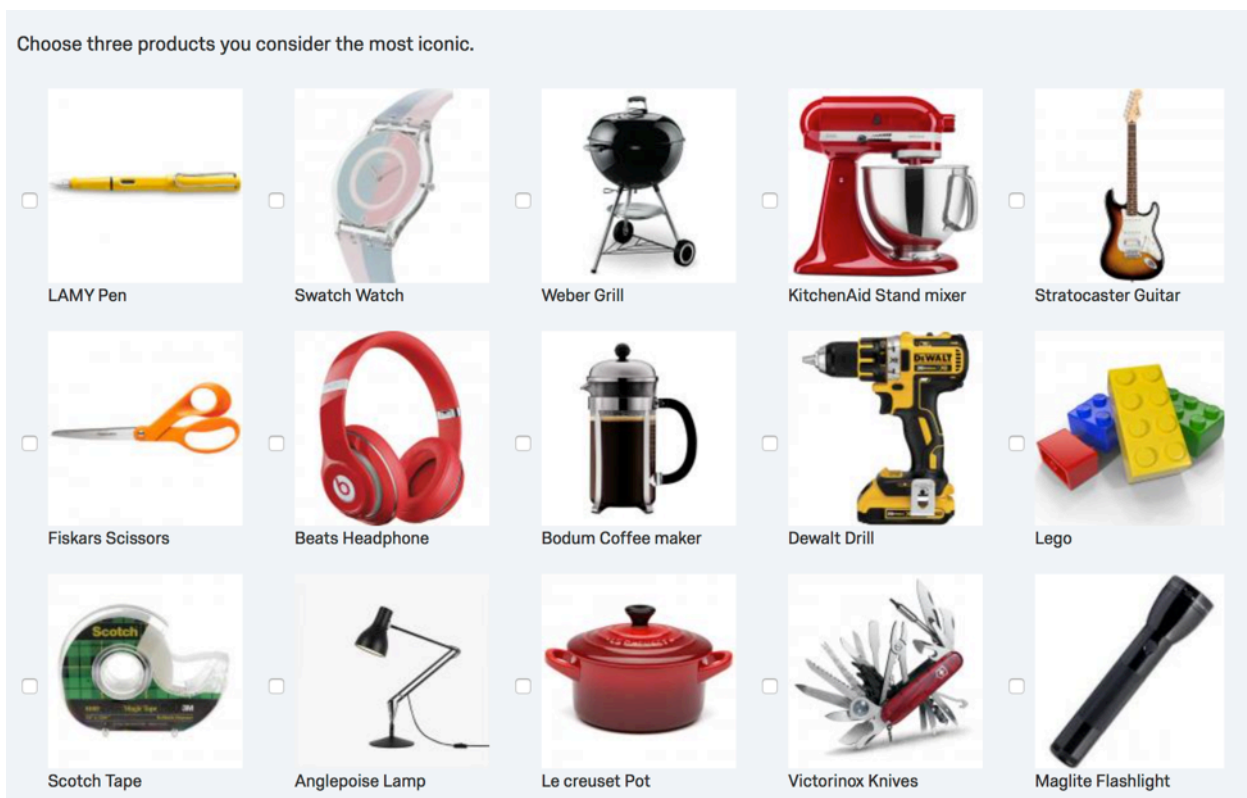

Figure 16, Question 4: Choose Three Products You Consider the Most Iconic.

Question 4: Choose three products you consider the most iconic.

This question with fifteen images of iconic products includes different types of products: pens, lamps, knives, guitars, etc. Respondents need to choose three products they consider the



most iconic within these options. Images in this question will show randomly to ensure the equity and quality of the survey.

What makes this product immediately identifiable?



	Least important	Slightly important	Neutral	Very important	Most important
Form (details)	<input type="radio"/>	<input type="radio"/>	<input type="radio"/>	<input type="radio"/>	<input type="radio"/>
Materials	<input type="radio"/>	<input type="radio"/>	<input type="radio"/>	<input type="radio"/>	<input type="radio"/>
Colors	<input type="radio"/>	<input type="radio"/>	<input type="radio"/>	<input type="radio"/>	<input type="radio"/>
Overall Appearance	<input type="radio"/>	<input type="radio"/>	<input type="radio"/>	<input type="radio"/>	<input type="radio"/>
Other <input type="text"/>	<input type="radio"/>	<input type="radio"/>	<input type="radio"/>	<input type="radio"/>	<input type="radio"/>

Figure 17, An Example of Question 5: What Makes This Product Immediately Identifiable?

Question 5: What makes this product immediately identifiable?

After choosing three iconic products, respondents have to think about why they made this choice and scale the importance of product design elements including form (details), materials, colors, and overall appearance of products. The overall appearance is defined as a combination of the number of specific form elements used and includes specific large form characters and shapes. The form (details) is defined as specific detail treatments used on a product icon. Materials and colors are specific materials and colors that are used on a product icon. The importance is divided into five levels, including least important, slightly important, neutral, very important, and most important. They could also enter other elements they think is essential to the product and scale that importance.

In summary, there are five questions in these three sections that help to collect different viewpoints about the definition of product icons and the priority of visual design elements for different product categories from respondents.

### 3.3 Data Collection

After distributing the survey to designers, several respondents took the survey anonymously. There were 53 survey responses collected, and 48 responses were considered valid. The data collection of each question in the survey is shown as follows.

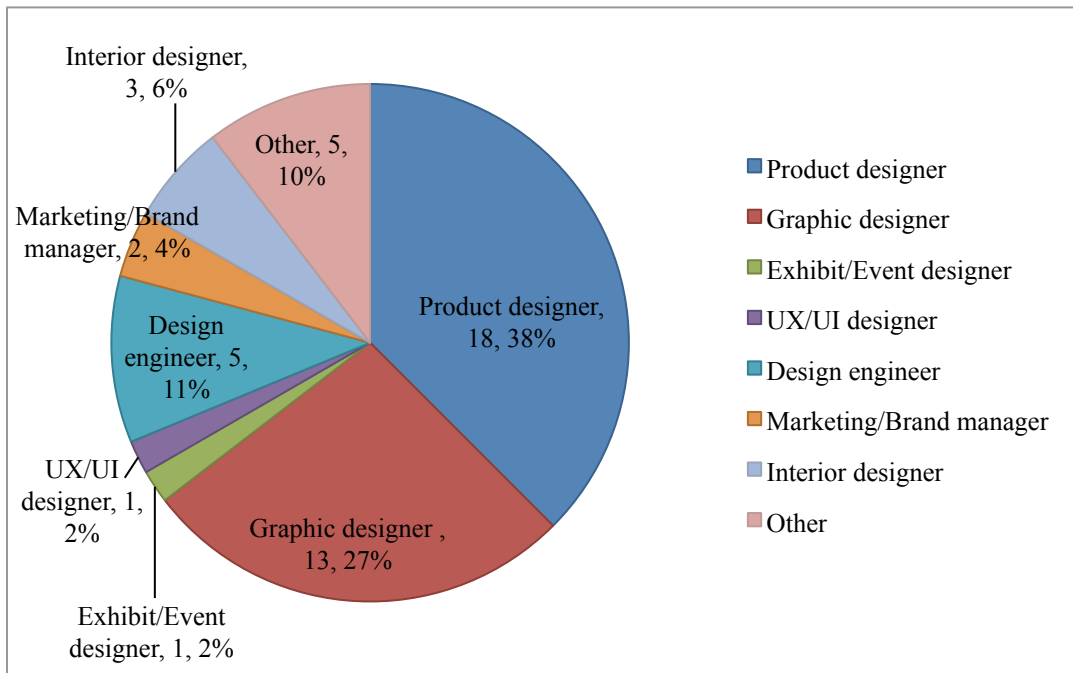

Figure 18, Data of Question 1: What is Your Primary Area of Expertise?

As data shows on Figure 18, seven different types of designers have filled in this survey, including product designers, graphic designers, exhibit/event designers, UX/UI designers, design engineers, marketing/brand managers, and interior designers. Product designers and graphic designers occupy great majority among respondents in this survey.

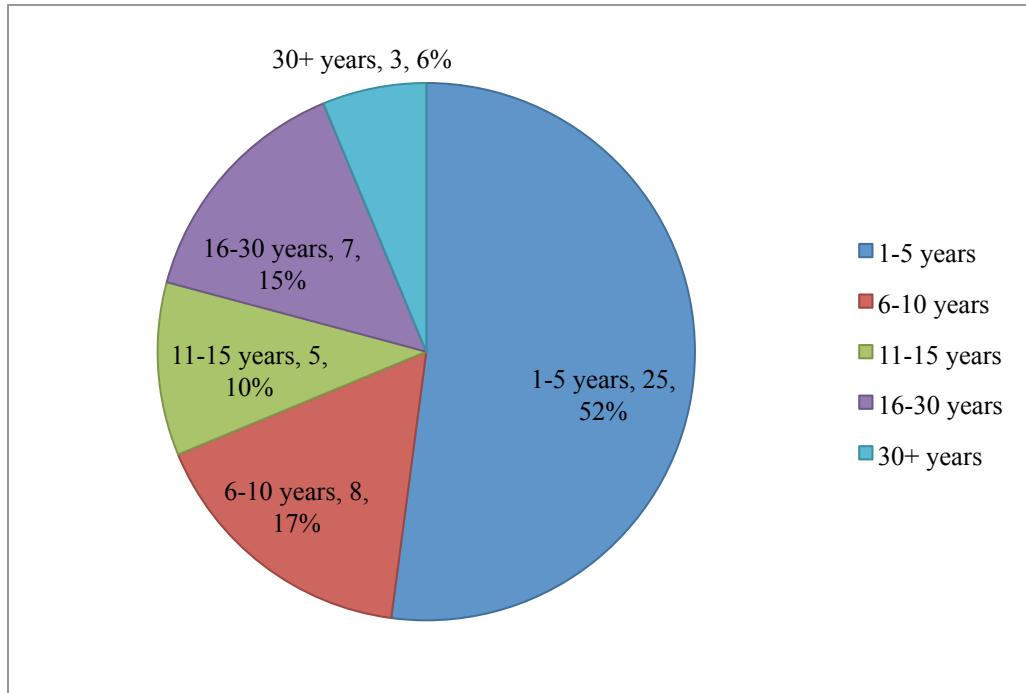

Figure 19, Data of Question 2: Years of Experience

For years of design experience, 52% of respondents are 1-5 years, and the rest of respondents have more than 5 years of design experience. The survey responses were varied as designers with different design experience could take the survey. In short, these two questions are designed for collecting some basic information and ensuring respondents' quality.

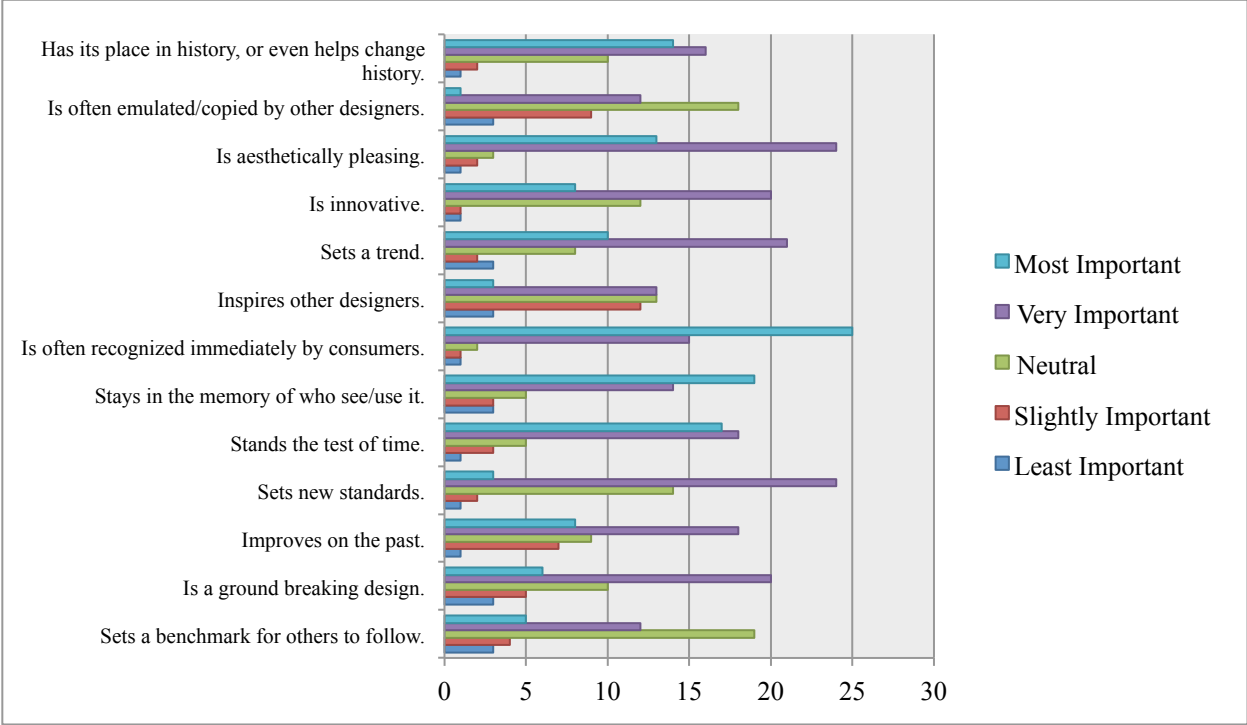

Figure 20, Data of Question 3: What Most Establishes a Product as an Icon?

Figure 20 shows the data collection of question 3 where respondents have to scale the importance of thirteen factors that establish a product as an icon. From the data, the majority of the factors are very important and a few factors are less important to most of the respondents. They selected the following as the most important factors of an icon: the product is often recognized immediately by consumers, stays in the memory of who see/use it, and stands the test of time. Respondents also think that when a product is a ground-breaking design, improves on the past, sets new standards, sets a trend, is innovative, is aesthetically pleasing, and has its place in history or even helps change history are all very important factors for establishing a product as an icon. However, when a product sets a benchmark for others to follow, inspires other designers, and is often emulated/copied by other designers are not so important in the opinions of respondents.

<b>The Primary Factors</b>	<b>The Secondary Factors</b>
<ul style="list-style-type: none"> <li>• Is often recognized immediately by consumers.</li> <li>• Stays in the memory of those who see/use it.</li> <li>• Stands the test of time.</li> </ul>	<ul style="list-style-type: none"> <li>• Is aesthetically pleasing.</li> <li>• Sets new standards.</li> <li>• Sets a trend.</li> <li>• Is a ground-breaking design.</li> <li>• Is innovative.</li> <li>• Improves on the past.</li> <li>• Has its place in history, or even helps change history.</li> </ul>

Figure 21, The Significance of Factors

According to data collection of question 3, the significance of factors to define a product as an icon could be divided into the primary factors and the secondary factors (Figure 21). Factors that respondents considered as most important are attributed to the primary factors. Factors that most respondents regarded as very important belongs to the secondary factors.

In summary, the result from the question 3 helps to build the following checklist. The checklist will consist of factors that have been scaled according to the importance given in the survey responses.

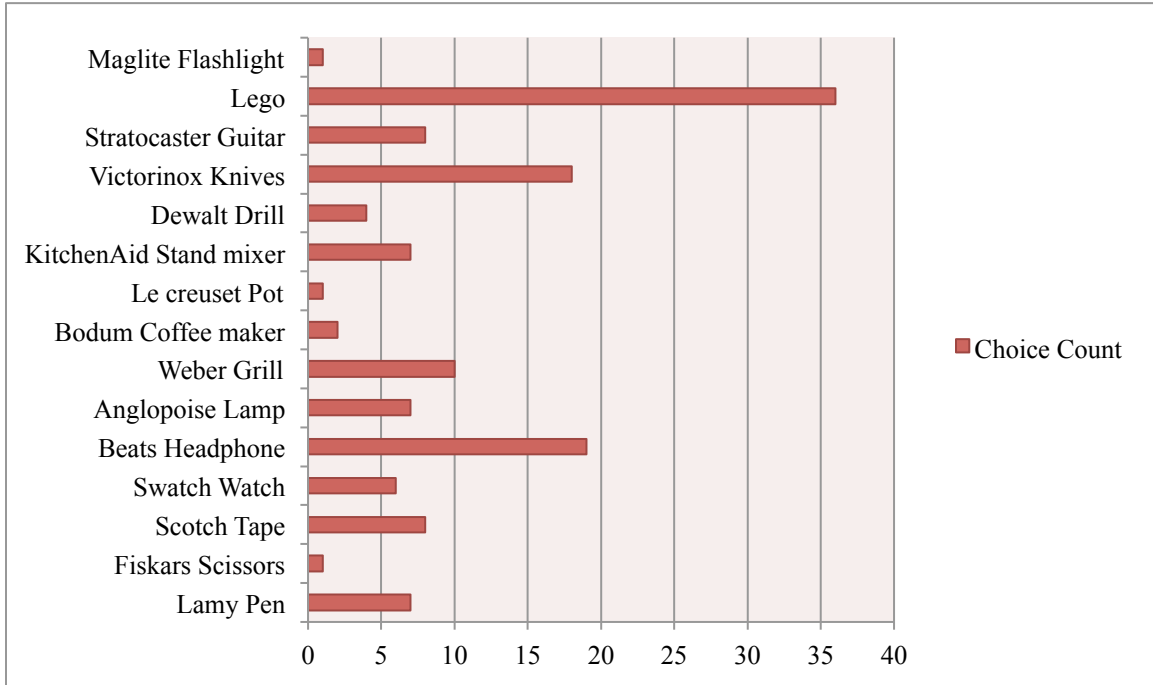

Figure 22, Data of Question 4: Choose Three Products You Consider the Most Iconic

Question 4 consists of fifteen iconic products. It asks respondents to select the most iconic products that they consider the top three. From the data collection, the majority of respondents regard Legos, Victorinox knives, Beats headphone, and Weber grills as products that are most iconic. No matter what choices respondents made, they had to scale the importance to indicate why they made these decisions.

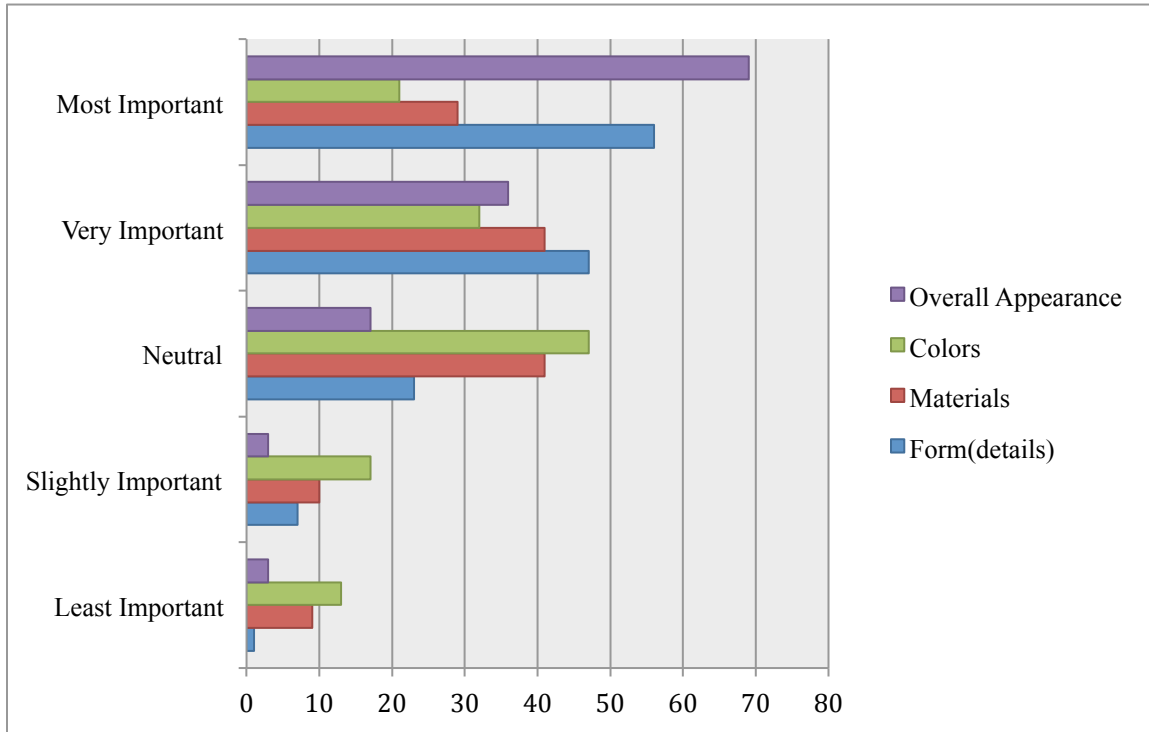

Figure 23, Sum Total Data Collection of Question 5

Figure 23 shows the sum total data collection of question 5 (What makes this product immediately identifiable?). The majority of respondents consider that overall appearance and form (details) of products to be two major aspects that make a product immediately identifiable. However, colors and materials are less important than those two elements. This represents that consumers' visual perception of a product icon is mainly via its overall appearance and form (details). They correspond to explicit design elements that are form elements and detail treatments. In summary, question 4 and question 5 help to explore the priority of explicit design elements of product icon.

### 3.4 Product Icon Checklist

**Product Icon Checklist**

The **Primary** Factors

- Is recognizable and memorable
- Stands the test of time

The **Secondary** Factors

- Is aesthetically pleasing
- Sets new standards
- Sets a trend
- Is a ground-breaking design
- Is innovative
- Improves on the past
- Has its place in history, or even helps change history

Figure 24, Product Icon Checklist

The product icon checklist is used to define a product as an icon (Figure 24). It came from the result of question 3 in this survey. It provides relevant factors to help designers to understand a product icon better. In the checklists, the primary factors and the secondary factors respectively corresponding to the table of the significance of factors (Figure 21). For the first primary factor, the original description is ‘is often recognized immediately by consumers’, and ‘stays in the memory of who see/use it’. To make it concise and easy to understand, the descriptions of these factors have been combined and simplified into ‘is recognizable and memorable’. The secondary



factors keep the same content as the secondary factors on the table of the significance of factors. It should be noted that “Is aesthetically pleasing” is a subjective factor while others are more objective because the perception of aesthetic is different from person to person. A product must meet all primary factors to be considered as an icon. The secondary factors are not so important for every product icon and could be selected depending on different conditions.

### **3.5 Conclusion**

This survey aided in collecting different viewpoint from several designers about how to define a product as an icon. The product icon checklist developed from the survey responses will help to verify a product as an icon. It also will be used to help to select iconic products as cases to be studied in the following chapter.

## **Chapter 4**

### **Product Icon Case Studies**

#### **4.1 Introduction**

This chapter will focus on the study of four iconic products from different brands. The aim of case studies is to explore how companies that own and produce a product icon develop their additional product lines. The product icon checklist that was created according to previous research and survey in the previous chapter will help to select the cases.

#### **4.2 Anglepoise**

##### **4.2.1 About Anglepoise Desk Lamp**



Figure 25, Anglepoise Type 75 Desk Lamp (Anglepoise, n.d.c)

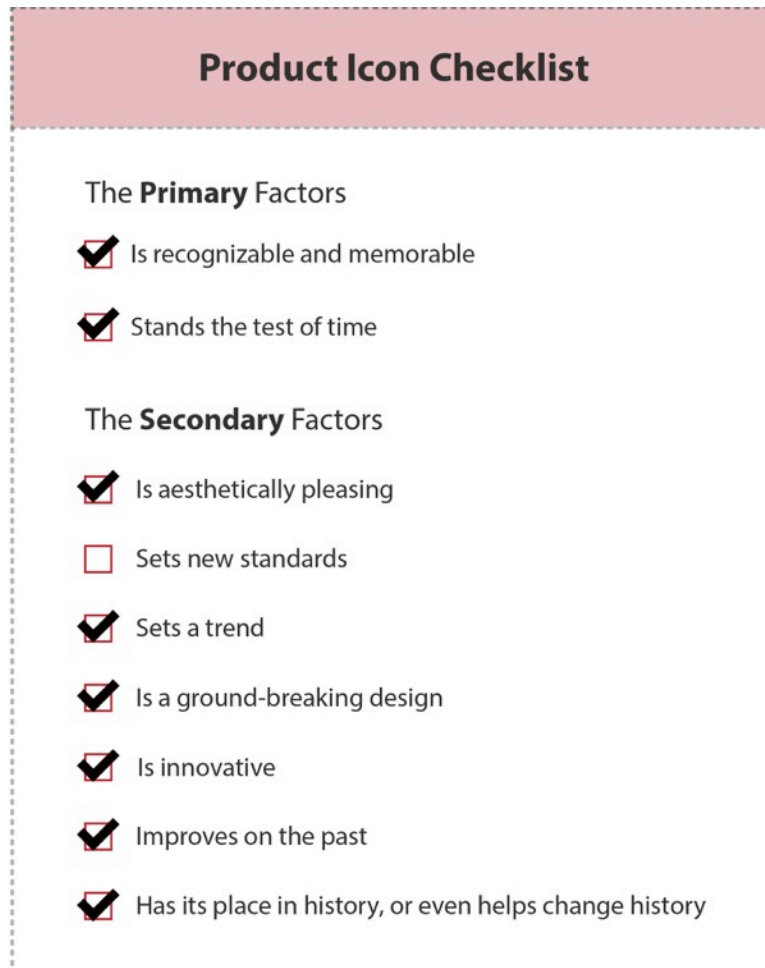

Figure 26, Checklist – Anglepoise Desk Lamp

Anglepoise is a brand from the UK that produces different lighting products, including desk lamps, wall and ceiling lamps, and floor lamps. Anglepoise has a long history from 1932 to the present, and it is popular around the world because of the four-spring ‘1209’ that has become an iconic design (Lewis, Chynoweth, & Wyke, 2014). Thus, it can be seen that the design of the Anglepoise lamps has stood the test of time. The form of Anglepoise desk lamp is easily recognizable and aesthetically pleasing. Even though the company has grown with different designers to design the product, Anglepoise’s lamp collection still retains common design elements that make products easier to recognize. George Carwardine, an automobile engineer, created the first four-spring Anglepoise desk lamp by using special springs that give the lamp

flexibility and a good balance. This shows the Anglepoise desk lamp is a ground breaking and innovative design. It also improves on the past and has its place in history because of its uniqueness and innovation. It sets a trend because Anglepoise lamps still can be found in different places including restaurants, home and office around the world until today (Anglepoise, 2017). Anglepoise lamp meets all primary factors and six secondary factors in the checklist. This makes it a strong candidate for further study.

**4.2.2 Analysis of Product Line Expansion**

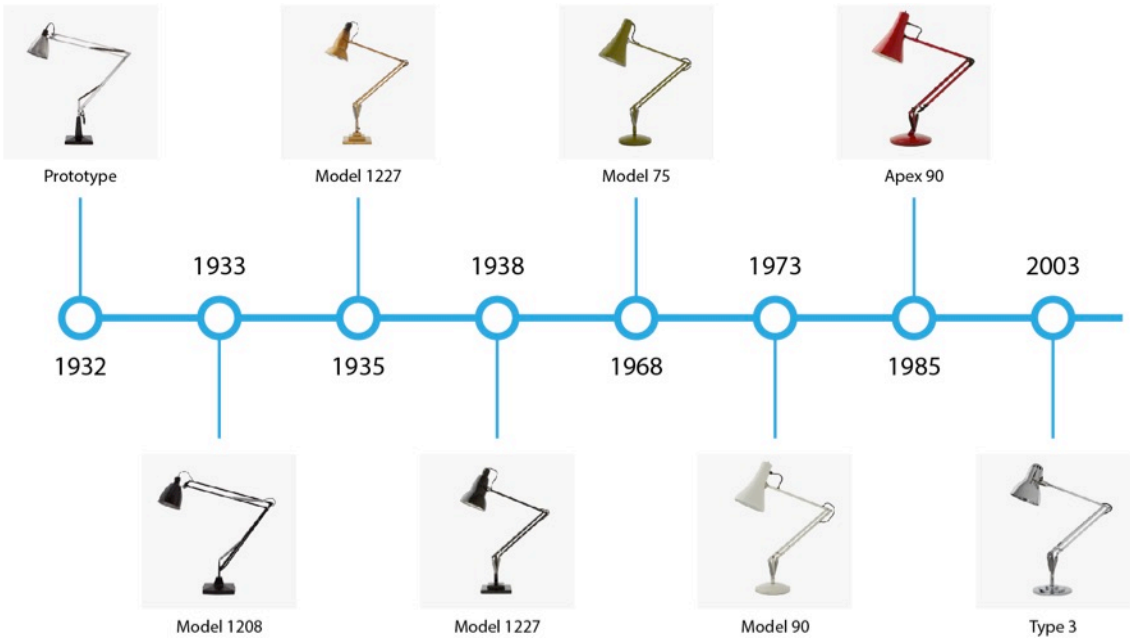

Figure 27, Timeline of Anglepoise Desk Lamp Development History (Part 1) (Anglepoise, n.d.a)



Figure 28, Timeline of Anglepoise Desk Lamp Development History (Part 2) (Anglepoise, n.d.d; Laban, 2008)

Figure 27 and Figure 28 show the timeline of Anglepoise lamp development. The data are drawn from the official website of the Anglepoise lamp (Anglepoise, n.d.b), and the official website of Design Museum (The Design Museum, 2014). The timeline demonstrates how the Anglepoise lamp developed, and each product edition and revision launched from 1973 to 2016. Anglepoise has been consistent in launching a new desk lamp from 1932 until the present day, and it began expanding its product lines in 2008. Except for shape of the shade and base, the form of the Anglepoise desk lamp seems not changed too much from the very first prototype until the 2016 versions.

## Analysis of Product Lines

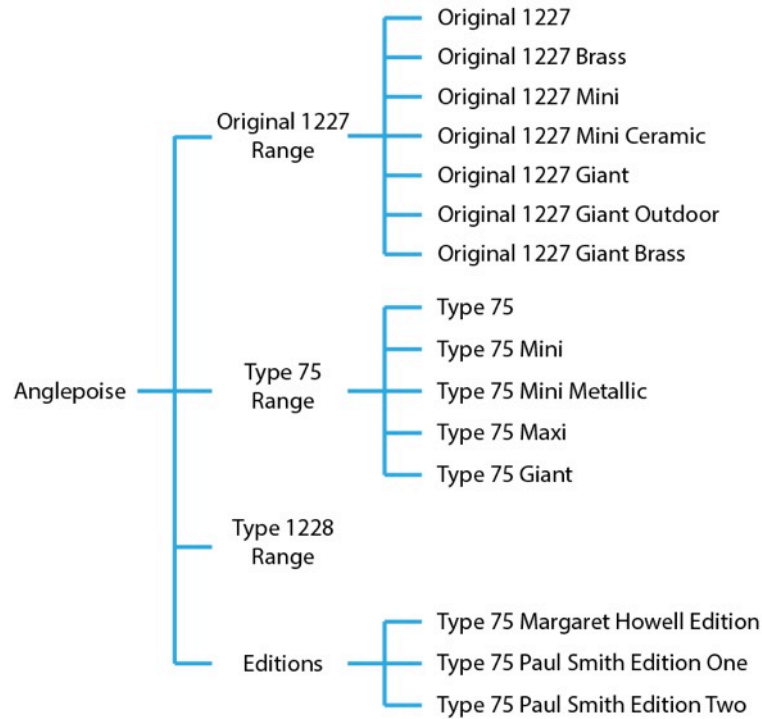

Figure 29, Product Lines of Anglepoise (Anglepoise, n.d.d)



Figure 30, An Example of Different Anglepoise Lamp Types and Dimensions

In the Anglepoise products family, Original 1227, Type 75, and Type 1228 are the three main lamp lines that have been expanded. The company is mainly expanding product lines by making products into different sizes, such as Original 1227 Mini collection, Type 75 Giant collection,

and Type 75 Maxi collection. In addition, different materials have been applied on several product lines, such as the Original 1227 Mini Ceramic collection, type 75 Mini Metallic collection, and Original 1227 Giant Brass collection. Beyond that, Anglepoise has further cooperated with designers and produced designer's edition lamps. These different dimensions and different materials lamp collection meet the needs of different spaces.

Originally, Anglepoise kept updating different editions of the desk lamp. However, more products, including a floor lamp, wall mounted lamp, pendant, and table lamp, have been added to the Anglepoise family while the company decided to expand their product lines. Most lamps encompass iconic design elements from the classic Anglepoise desk lamp. For the design of the desk lamp, table lamp, and floor lamp, most of them follow the style of the Anglepoise desk lamp that consists of a shade, arms, and a base. For the wall light and pendant that contains a shade only, they also follow the Anglepoise design style.

Anglepoise aims to become a contemporary lighting company but does not lose sight of its heritage (Anglepoise, 2017). It produces a unique series of practical, efficient and energy-saving task lamps that suit for both domestic and commercial interiors use (Anglepoise, n.d.b). These are brand values of Anglepoise, which the company continues to use in entire product lines.

Figure 30 shows an example of different Anglepoise lamp types and dimensions. The form of Anglepoise lamp collections almost has similar product design elements. In addition to that, the differences among the design of lamps are the scale and the lighting output (capacity). Obviously, the major difference of these products is their dimensions. The classic desk lamp has been scaled up to a giant floor lamp and scaled down to a mini desk lamp without changing its base and shape appearance. The floor lamp keeps the classic Anglepoise shade silhouette and

spring structure with a long pole. The pendant keeps the shade of the classic Anglepoise desk lamp and created a maxi version.

In summary, Anglepoise has expanded products lines and developed several new lamp collections by scaling up and scaling down the dimension of the lamps, and also adjusting the lighting output (capacity) of products. The design of most lamps in these collections follows the Anglepoise style and is still recognizable.

## 4.3 Fiskars

### 4.3.1 About Fiskars Scissors



Figure 31, The Original Orange-handled Scissors from Fiskars (Fiskars, n.d.b)

Fiskars was established in 1649 in Fiskars village in Finland, and it used to be an ironworks. The company has become a global supplier of this consumer product for home, garden and outdoors through more than 365 years of developments. Today, Fiskars Corporation is under a strong portfolio of globally recognized brands including Fiskars, Iittala, and Gerber. Fiskars has launched various products into the global market. Product categories include kitchen, living, creating, boats and so on. For the market in North America, Fiskars gains benefit from their strong position including crafting and sewing tools, garden hand tools, and knives and multitools. This case study will mainly discuss Fiskars products in the North America market.



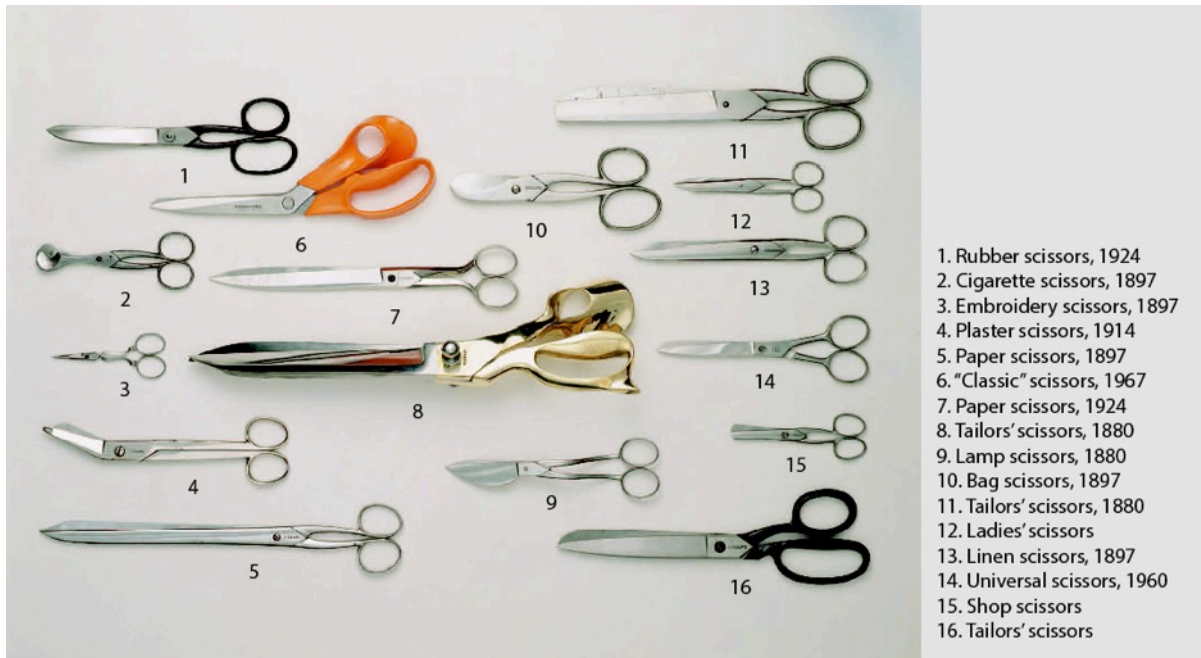

Figure 32, Fiskars Scissors from Two Centuries (Fiskars, n.d.a)

### Product Icon Checklist

**The Primary Factors**

- Is recognizable and memorable
- Stands the test of time

**The Secondary Factors**

- Is aesthetically pleasing
- Sets new standards
- Sets a trend
- Is a ground-breaking design
- Is innovative
- Improves on the past
- Has its place in history, or even helps change history

Figure 33, Checklist – Fiskars Scissors

Figure 32 shows the development of Fiskars scissors through two centuries. Fiskars scissors were made of steel before it launched the world's first plastic-handled scissors in 1967. Fiskars orange-handled scissors have become a true design icon through the years (Fiskars, 2014). Today, people still can recognize Fiskars scissors by its orange handles from the first image. This shows that the design of Fiskars scissors was stood the test of time and had its place in history. The form of the original Fiskars scissors is recognizable, memorable and aesthetically pleasing because of the distinctive bright orange and the unique shape of the handle. The bright orange handles make the scissors funny, stand out of the changeless cutting room and easy to locate (Lidwell & Manacsa, 2009). The orange color was a coincidence choice due to orange pigment left over in the machine from the production of juicers. The orange grip defeated the black in the final vote, of 9-7. The design of the handles' shape aimed to improve scissors ergonomics and enhance user experience (Fiskars, n.d.a). Thus, it can be seen that the Fiskars scissors is a ground-breaking design, is innovative, and improves on the past. Fiskars scissors meets all primary factors and five secondary factors in the checklist, which makes it a strong candidate for further study.

### 4.3.2 Analysis of Product Line Expansion



Figure 34, Fiskars Scissors 1967-2007 (Fiskars, n.d.a)

Fiskars is continuing innovation and expanding its product lines for different aspects of daily life such as gardening and outdoors tools, special scissors for crafting and sewing, and safety scissors for kids use. Figure 34 is the family tree of Fiskars scissors from 1967 to 2007. In addition to enhancing the comfort of product use the primary color of Fiskars scissors handle is orange in this period of product development.

## Analysis of Product Lines

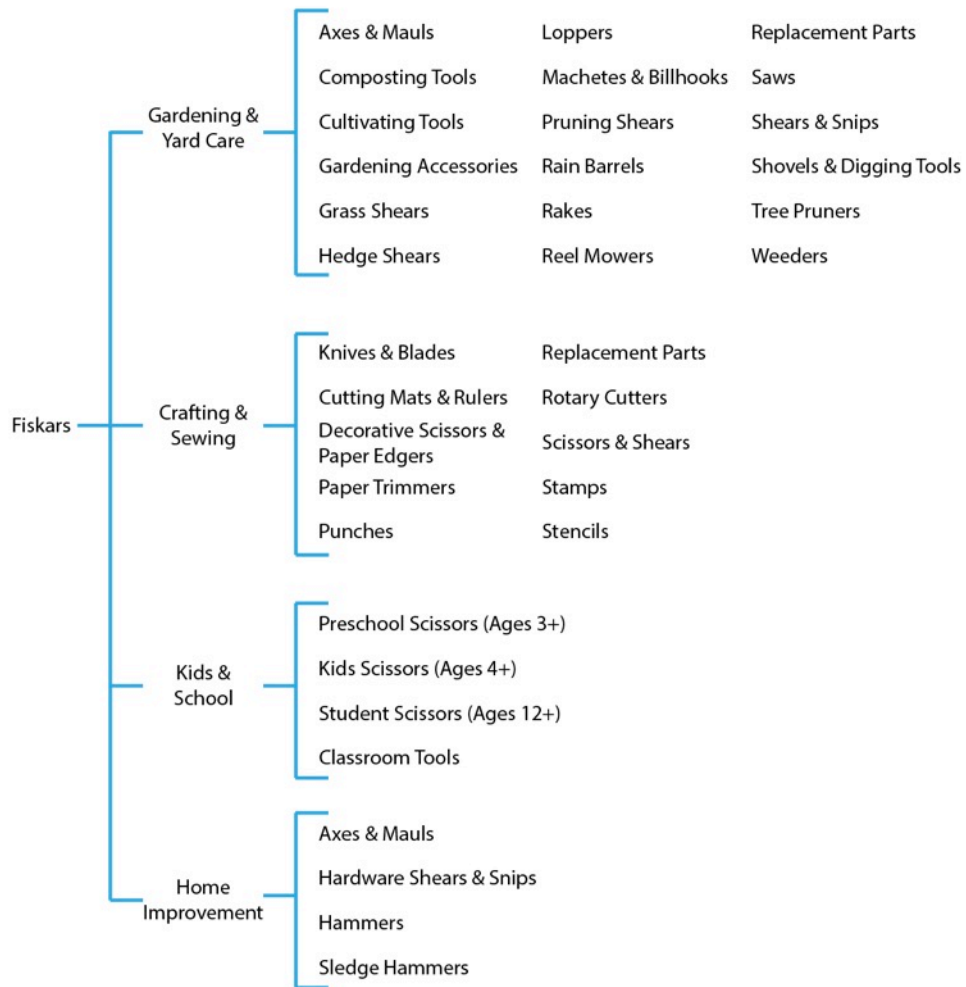

Figure 35, Product Lines of Fiskars (Fiskars, n.d.c)

Figure 35 shows clear product lines of Fiskars. The company focuses on producing a lot of different type of tools for gardening and yard care, crafting and sewing, kids and school, and home improvement use.



Figure 36, Tools Design of Fiskars (Fiskars, n.d.d)

There are many different function tools that have been introduced to the market by Fiskars. Looking through gardening and yard care products, it is obvious that the Fiskars orange has been applied on most of the handles of products. The Fiskars orange has also been designed for crafting and sewing products so that the color on these products design is harmonious and easy to recognize. The handle design of scissors not only contains the Fiskars color but also the special and ergonomic shape. For kids and school product lines, it is not like other product lines that have been designed with Fiskars orange on appearances because products with different colors may attract more kids to use. The handle design of scissors still keeps the ergonomic shape that comfortable for kids to use. The design of home improvement is the same as the design of gardening and yard care products. In summary, the Fiskars orange has been applied on most of the handles' design of these products.

The design philosophy of Fiskars is to make products better and smarter. Meanwhile, Fiskars aims to make products that are functional and user-friendly with longevity and aesthetic appeal. The consistency of Fiskars scissors portfolio not only enhances brand identity but also deepens the brand image in consumer's minds.

To summarize, Fiskars extends product lines by continuing to use its unique color on products. Most tools have been designed with the Fiskars orange. In this case, Fiskars orange can be regarded as an existing color palette, and the company uses this palette to extend new product lines.

#### 4.4 Bialetti

##### 4.4.1 About Bialetti Moka Express



Figure 37, Bialetti Moka Express Coffee Maker (Bialetti, n.d.b)

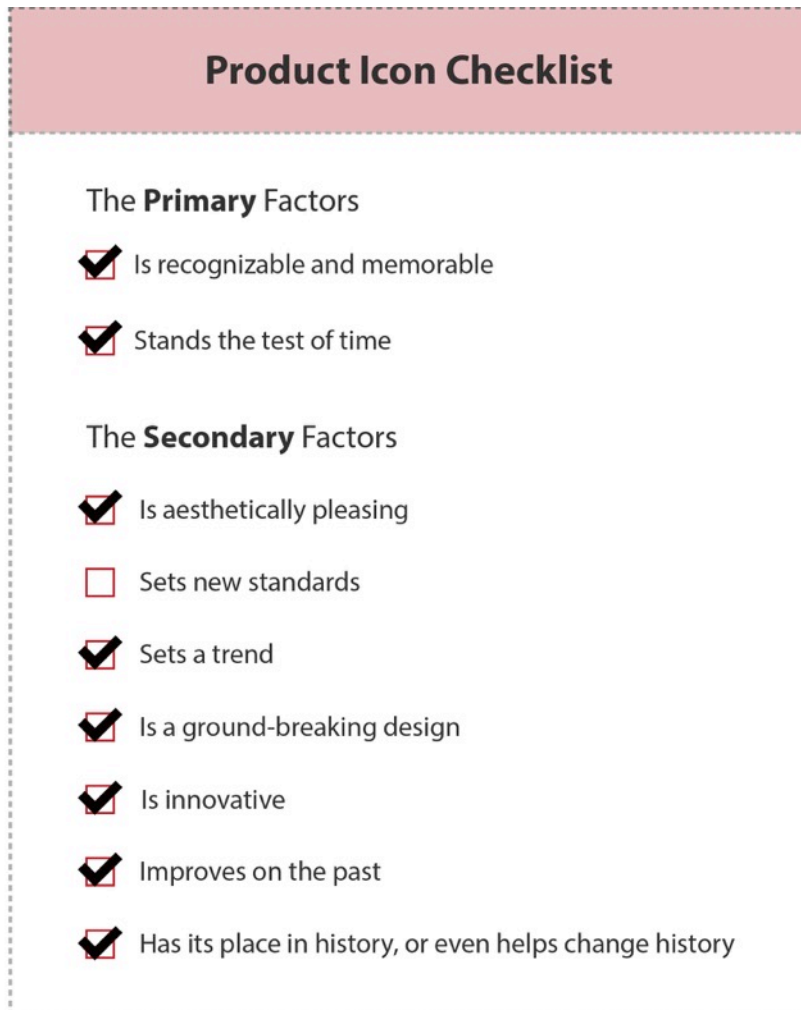

Figure 38, Checklist – Bialetti Moka Express Coffee Maker

Bialetti coffee maker is recognizable, memorable, and aesthetically pleasing because it has a distinctive form with a faceted and waisted shape. It is an iconic product and has been collected by the Museum of Modern Art in New York. Bialetti is an Italian brand born in 1919. Alfonso Bialetti introduced the first Moka Express coffee maker in 1933. Thus, it can be seen the product design was stood the test of time. The idea of designing this coffee maker came from Alfonso Bialetti watching his wife doing laundry. The wash was boiled in tubs with a central pipe in the middle, which would draw the soapy water up and redistribute it over the laundry. The invention of the Moka Express coffee maker allowed Italians to have real espresso in their home. The new technology of the coffee maker has revolutionized the way that people make coffee at home. In

addition, people are still using this coffee maker until today. These show that Bialetti Moka Express is a ground-breaking design, is innovative, sets a trend, and improves on the past and helps change history. Even though it is so popular that it has been widely copied, those copies cannot match the originals that are made of aluminum that has been smelted once only (Albus, Kras, Woodham, Bosomworth, Breward, Fischer et al., 2000). Bialetti Moka Express coffee maker meets all primary factors and six secondary factors in the checklist. Thus, it is a strong candidate for further study.

#### 4.4.2 Analysis of Product Line Expansion



Figure 39, The First Moka and The First Design Revision (Bialetti, n.d.a; First Versions, n.d.)

Figure 39 shows that the form of Bialetti Moka Express coffee maker has changed little since it was first launched. The main difference between the first model and the first design revision is the bottom part and the handle part.



## Analysis of Product Lines

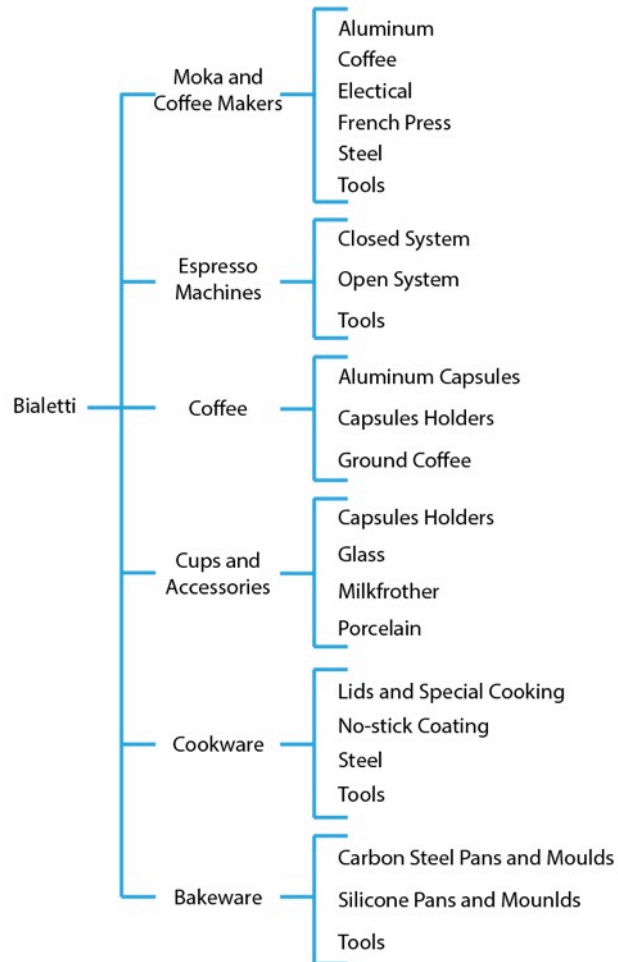

Figure 40, Product Lines of Bialetti (Bialetti, n.d.c)

Although the Bialetti Moka Express coffee maker is very famous and popular, the company still considers how to develop its product lines. Product categories of Bialetti have become more and more diverse through years' development. Besides the Moka Express coffee maker, Bialetti also produces electrical espresso machines, cookware, bakeware, cups, etc.



Figure 41, Moka and Coffee Makers of Bialetti (Bialetti, n.d.c)

Figure 41 shows the Moka and coffee maker product line of Bialetti in the recent product portfolio. The classic Bialetti Moka express coffee maker has a particular octagonal shape with a slim waist. However, the design of several coffee makers is not continuing the classic octagonal shape. In addition to similar form and function, most coffee makers keep a similar structure and proportions with the classic Moka express coffee maker. These coffee makers could be separated into an upper part and a bottom part with a similar proportion of each part. Moreover, the Bialetti brand continues expressing its brand value including genuine pleasure, expertise, and passion.



Figure 42, Espresso Machines of Bialetti (Bialetti, n.d.c)

Although the design of espresso machines from Bialetti is different from Moka and coffee makers, some of them are still attempting to hold the structure and proportions of the classic Bialetti Moka Express coffee maker (Figure 42).

It should be noticed that Bialetti has also developed additional product lines in the kitchen and bakeware that bear little resemblance to their product icon. For clarity in describing the structure and proportions approach, these are not illustrated here.

In summary, most Bialetti coffee maker products have similar form design and function. The company extended the product line of coffee makers by utilizing a similar structure and proportion to the product icon.

## 4.5 KitchenAid

### 4.5.1 About KitchenAid Stand Mixer



Figure 43, KitchenAid Artisan® Design Series 5 Quart Tilt-Head Stand Mixer (KitchenAid, n.d.a)

### Product Icon Checklist

The **Primary** Factors

- Is recognizable and memorable
- Stands the test of time

The **Secondary** Factors

- Is aesthetically pleasing
- Sets new standards
- Sets a trend
- Is a ground-breaking design
- Is innovative
- Improves on the past
- Has its place in history, or even helps change history

Figure 44, Checklist – KitchenAid Stand Mixer

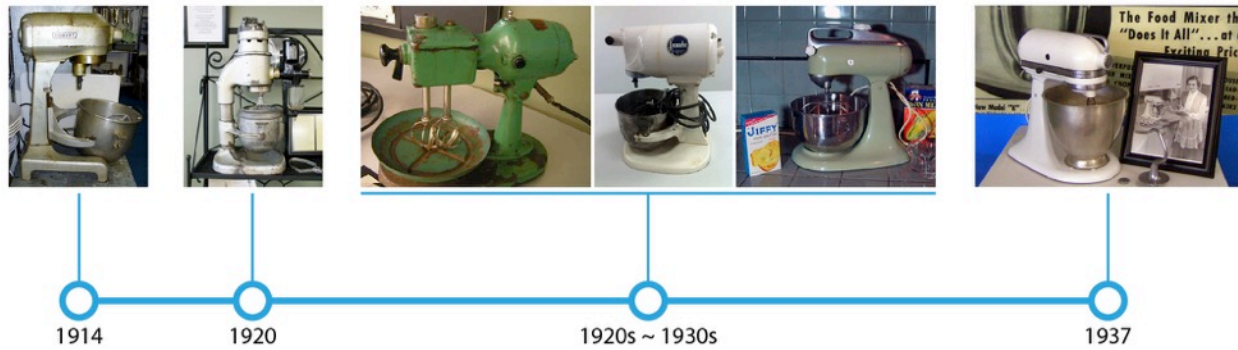

Figure 45, Development Timeline of KitchenAid Stand Mixer (Maker Inc, 2014)

KitchenAid is a US company that produces premium-price home appliances, including dishwashers, refrigerators, and microwave and so on. The iconic KitchenAid stand mixer has a distinctive form. The silhouette is aesthetically pleasing. This shows the product is recognizable and memorable. The iconic stand mixer that was designed by Herbert Johnson was born in 1919. After seeing a baker mix dough by hand, he decided to create a more efficient mechanical way to do the job. The stand mixer is the answer. It became wildly popular in the time of 1920s and 1930s. In the early 1930s, Egmont Arens designed the Model K with his humaneering approach (an approach for designing the full range of sensory experience, which makes products relaxing to the eyes, pleasing to the touch, muffling noises that jarred the ears, eliminating offensive odors, and so on) that made this new stand mixer functional and aesthetic, and it has remained basically unchanged for more than 70 years (Lidwell & Manacsa, 2009). Thus, the design of KitchenAid stand mixer was stood the test of time, and set a trend. It is also a ground-breaking and innovative design because the design helps to free bakers' hands. Thus, it can be seen that it improves on the past and helps to change the history. KitchenAid stand mixer meets all primary factors and six secondary factors in the checklist. Thus, it is a strong candidate for further study.

## 4.5.2 Analysis of Product Line Expansion

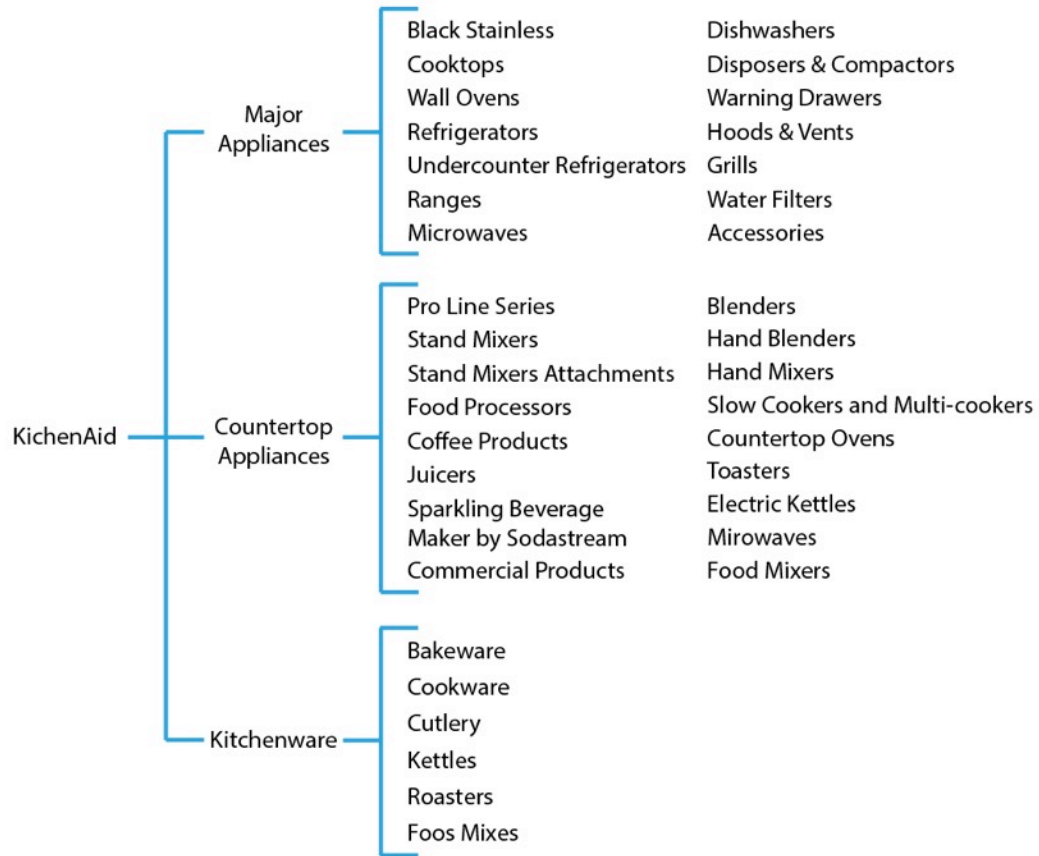

Figure 46, Product Lines of KitchenAid (KitchenAid, n.d.b)

KitchenAid has expanded its product lines into three major product categories including major appliances, countertop appliance, and kitchenware. The company released many products with different functions for kitchen use.



Figure 47, Explicit Design Elements of KitchenAid (KitchenAid, n.d.a)



Figure 48, Countertop Appliances of KitchenAid (KitchenAid, n.d.b)

Figure 48 shows the countertop appliances line of KitchenAid. The company expanded the product line by using repetitive design elements. Most of the countertop appliances products attempt to hold the core product visual design elements of KitchenAid. Some of them use the same color (KitchenAid red) on product bodies. They have similar explicit design elements, such as the large radii and the banded metal ring. Meanwhile, most countertop application products also have an extensive color palette.

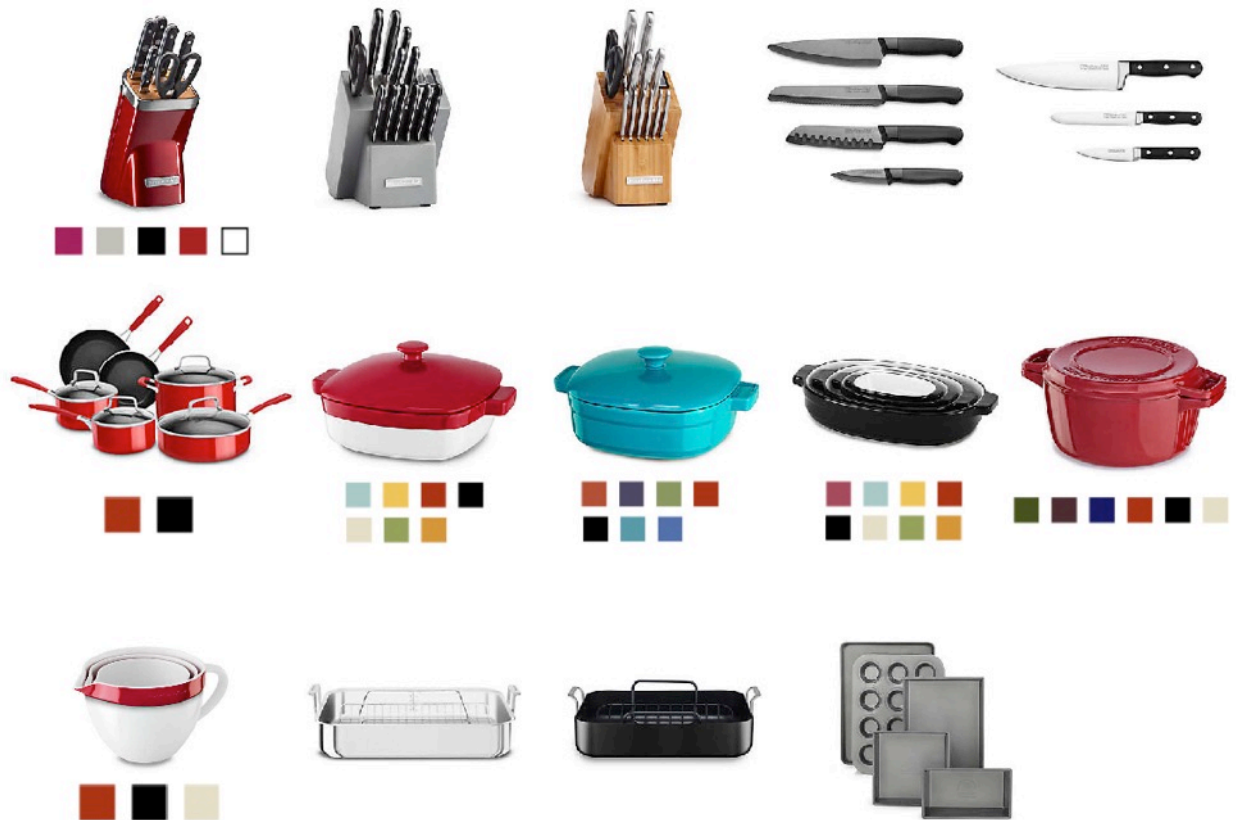

Figure 49, Kitchenware of KitchenAid (KitchenAid, n.d.b)

The Kitchenware design keeps parts of the brand visual language of KitchenAid. For example, the die cast cutlery knife block attempts to hold the iconic color of the iconic KitchenAid stand mixer.





Figure 50, Major Appliances of KitchenAid (KitchenAid, n.d.b; KitchenAid, 2015)

The form of most major appliances products is not following the style of the iconic KitchenAid stand mixer. Some of them have the KitchenAid brand medallion designed on the side of handles. The brand medallion is an iconic finishing stamp of KitchenAid with iconic KitchenAid red. The company transferred this detail treatment through some products of major appliances.

Meanwhile, KitchenAid aims to design a product that signifies attention to detail, quality craftsmanship, versatile technology and timelessness. These brand values are expressed through the entire product portfolio.

To summarize, KitchenAid expanded its product lines using repetitive design elements. Most of the countertop appliances utilize similar colors, form elements, and details treatments of the iconic KitchenAid stand mixer. Some of the kitchenware design continues utilizing the explicit design elements of KitchenAid. For major appliances, most of them use a specific detail treatment to show they belong to KitchenAid.

## 4.6 Conclusion

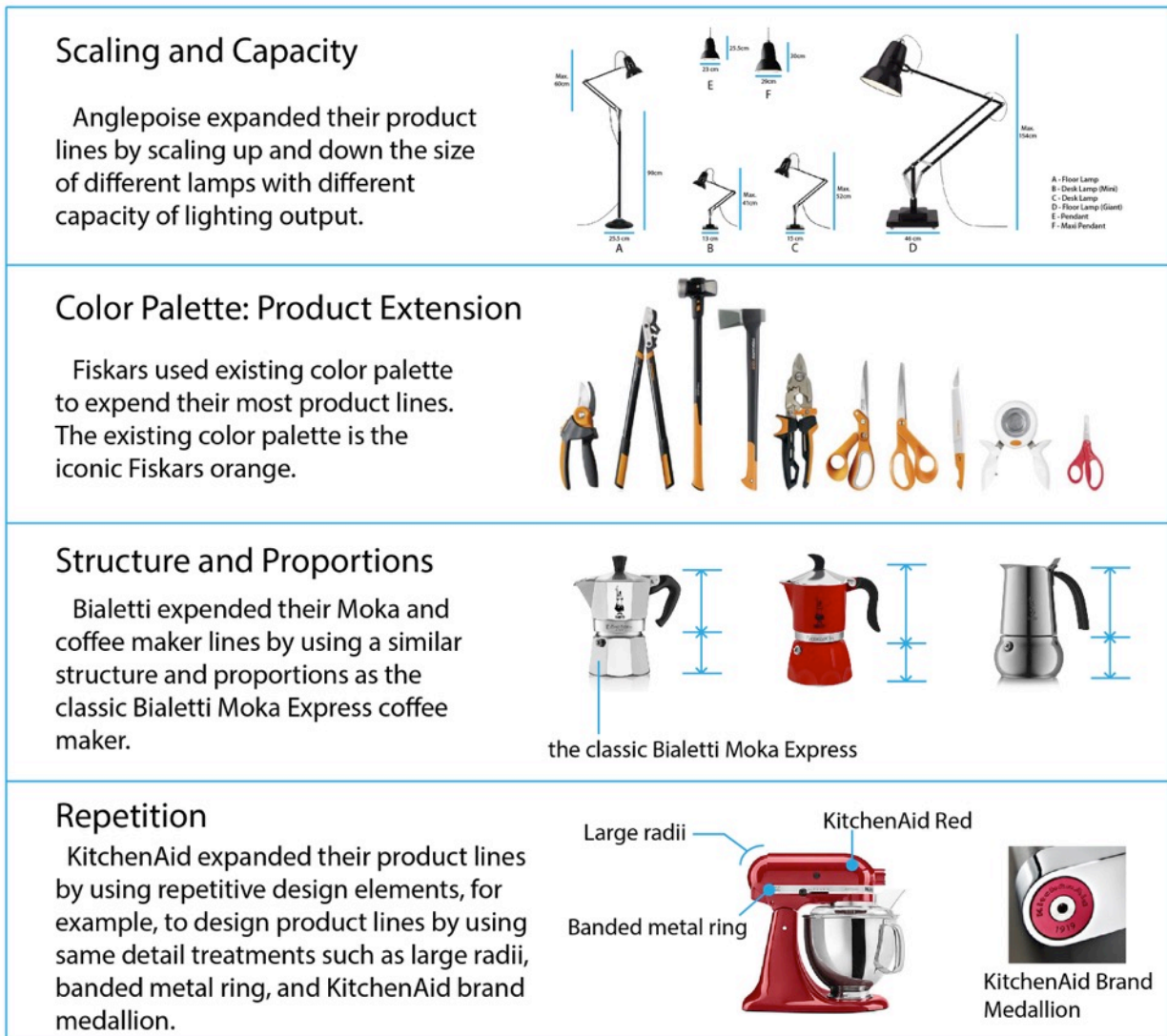

Figure 51, Design Approaches Summary

Four product icon case studies demonstrate four approaches for expanding product icon into product lines (Figure 51). The demonstration order of case studies is from a single product type to multiple product types expansion lines. For this study, Anglepoise expands product lines only within lamps, while KitchenAid expands its product lines into many more different product types.

Moreover, the color palette design approach should be divided into two aspects, product extension and palette extension. The product lines of Fiskars are an example of product extension that mentioned above. For palette extension, the Western Electric Model 500 telephone is an example.



Figure 52, Western Electric Model 500 Telephone (Nbhdttestblog, 2012)

**COLORS**  
*Most telephone sets manufactured by Western Electric are available in a wide variety of colors. They are normally supplied with color coordinated handsets, cords, and faceplates. Colors of various items in this catalog may be identified by the numerical suffix of the code number.*

-72 ● LIGHT YELLOW	-93 ● LEMON YELLOW	-123 ● BUTTER YELLOW	-56 ● PASTEL YELLOW	-111 ● HARVEST GOLD	-112 ● ORANGE
-124 ● RUST	-75 ● MUTED BEIGE	-60 ● LIGHT BEIGE	-113 ● BROWN	-104 ● CHOCOLATE BROWN	-59 ● ROSE PINK
-114 ● BRIGHT RED	-53 ● CHERRY RED	-69 ● MUTED RED	-62 ● AQUA BLUE	-78 ● MUTED BLUE	-115 ● ROYAL BLUE
-64 ● TURQUOISE	-106 ● LIME GREEN	-71 ● LIGHT GREEN	-100 ● AVOCADO	-51 ● MOSS GREEN	-105 ● DARK GREEN
-58 ● WHITE	-50 ● IVORY	-49 ● LIGHT OLIVE GRAY	-61 ● LIGHT GRAY	-3 ● BLACK	-118 ● TEXTURED BLACK
-122 ● MATTE ALUMINUM	-113 ● TEXTURED BROWN	-29 ● TRANSPARENT	-108 ● FEAX	-109 ● WALNUT	-87 ● SATIN SILVER

*Color Chart*

For additional information or to consult with your Western Electric Account Executive,  
 Write to: Western Electric  
 Commercial Sales  
 P.O. Box 28000  
 Greensboro, North Carolina 27420  
 or Call: 800-334-8155

Western Electric 6/83

11-1

Figure 53, Color Palette of Western Electric Model 500 telephone (Beatrice Companies Inc, n.d.)

The Western Electric Model 500 telephone was the domestic standard desk telephone set used by Bell System in North America from the late 1940s to 1984. From 1949 to 1953, the Model 500 was available in black only. Its palette was updated with a variety of colors after 1953, shown in Figure 53. Hence, Western Electric Model 500 telephone extended its product line by using a new color palette with the existing product.

In summary, these four case studies show four different approaches that are able to expand product icons into product lines. These approaches consist of scaling and capacity, color palette (product extension, and palette extension), structure and proportion, and repetition. Product icons with specific form elements and/or detail treatments could use design approaches to do product design such as scaling and capacity, and structure and proportion. Product icons with an iconic color could use the color palette approach to expand their product lines. The repetition could be used in the process of expanding product lines from product icons that have different kinds of explicit design elements.

## **Chapter 5**

### **An Approach for Designing Product Lines Using Product Icon Analysis**

#### **5.1 Introduction**

This chapter will develop an approach for transforming a product icon into product lines. The development of this approach is based on the design elements theory from the literature review, and the analysis from the product icon definition survey and case studies.

#### **5.2 The Approach and Procedure**

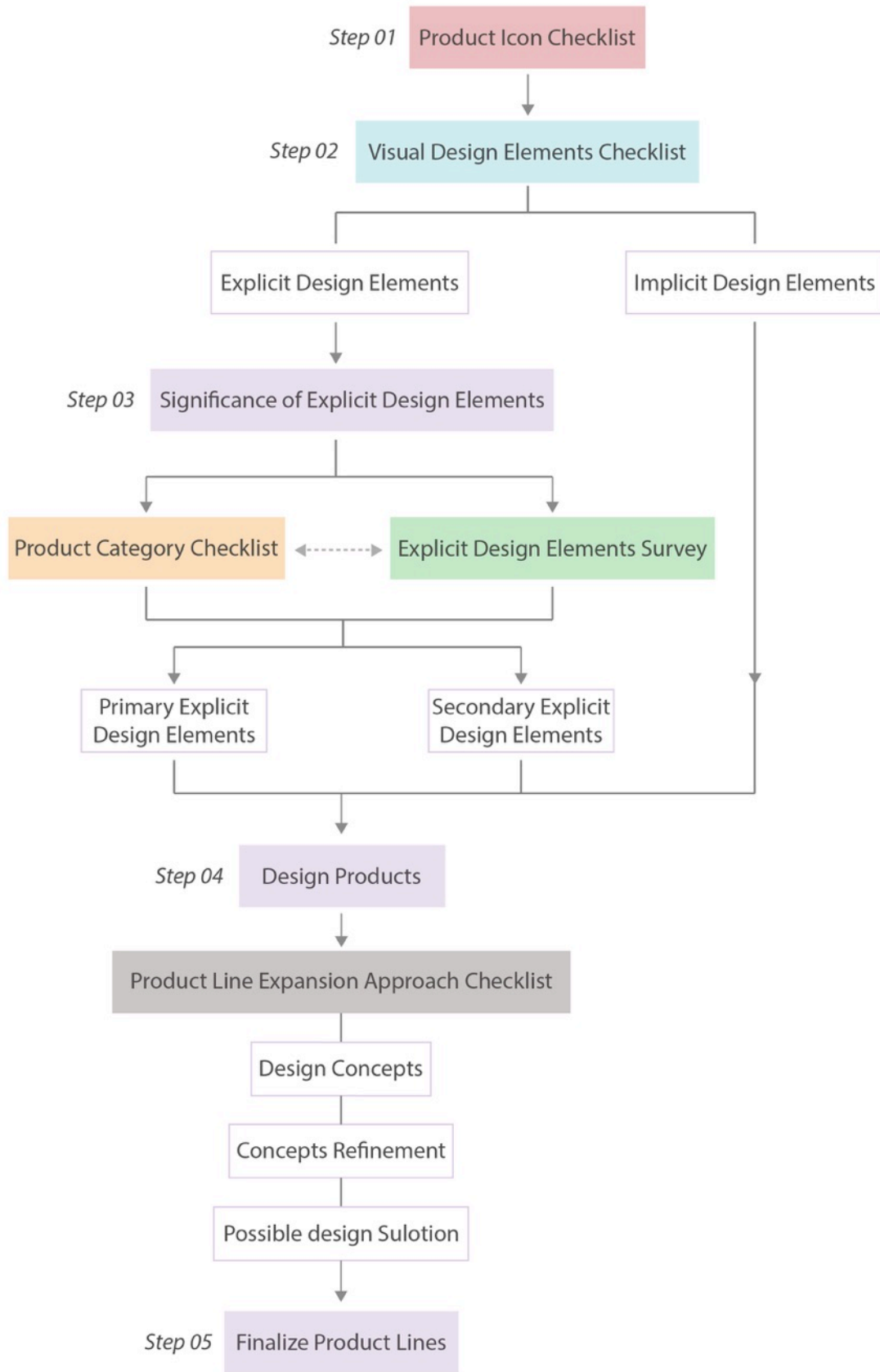

Figure 54, An Approach for Designing Product Lines Using Product Icon Analysis

## Procedure

- Step 1: Product Icon Checklist. To verify the selected product is an icon is the prerequisite, use this approach. The product icon checklist could help to exclude some products that do not meet the conditions. The product should meet all primary factors in the checklist to be considered as an icon.
- Step 2: Visual Design Elements Checklist. Explicit design elements and implicit design elements are two important visual design elements of a product icon. Analyzing the product icon could help to get its specific visual design elements that may be used for further product design process. Verify the specific visual design elements by checking the visual design elements checklist.
- Step 3: Significance of Explicit Design Elements. This step should prioritize explicit design elements of the product icon because implicit design elements are always carried through to additional designs. There are two methods to prioritize explicit design elements into primary explicit design elements and secondary explicit design elements. These two ways could be used alone, or together. The product category should be the category of the final product design and product lines that the designer plans to design. The product category checklist and explicit design elements survey may be used in this step.
- Step 4: Design products. First step in designing products is deciding to use one or several approaches from the product line expansion approach checklist. This may help designers with a clear design direction, and also help them to use product visual design elements effectively. Next, is to design concepts and refine concepts. Visual design elements including primary design elements and implicit design elements

should be applied to these two steps. The secondary design elements are selectively used. The final will yield a possible design solution.

- Step 5: Finalize product lines. Gather all final product designs to create product lines.

### 5.3 Product Icon Checklist

The image shows a checklist titled "Product Icon Checklist" enclosed in a dashed border. The title is in a red header box. Below the title, the checklist is divided into two sections: "The Primary Factors" and "The Secondary Factors". Each section contains a list of items with a red square checkbox to the left of the text.

**Product Icon Checklist**

The **Primary** Factors

- Is recognizable and memorable
- Stands the test of time

The **Secondary** Factors

- Is aesthetically pleasing
- Sets new standards
- Sets a trend
- Is a ground-breaking design
- Is innovative
- Improves on the past
- Has its place in history, or even helps change history

Figure 55, Product Icon Checklist

Figure 55 is the product icon checklist that is used for verifying the product is an icon. Based on the product icon survey in Chapter 3, these checkpoints have been divided into two sections: the primary factors, and the secondary factors. A product that meets all primary factors in the



checklist could be considered as an icon. A product icon does not need to meet all secondary product elements.

### **The Primary Factors**

The first section of the product icon checklist contains the primary factors. The primary factors are the prerequisite for defining a product as an icon. A product that meets these two factors is an icon and also can be assessed by the second section.

1. **Is recognizable and memorable:** The product icon must have a distinctive form that people could recognize and remember.

2. **Stands the test of time:** The product must have a long history and remain popular despite the passing of years in the market. According to the case studies, the minimum history among those product icons is about fifty years. Thus, a product that stands around fifty years of the test can be considered as an icon.

### **The Secondary Factors**

The secondary factors are able to be checked when the product meets all primary factors. There are seven factors in the second section of the checklist. This section is optional.

1. **Is aesthetically pleasing:** The product may provide people with visual comfort and a sense of beauty. This is a subjective factor that depends on different situations.

2. **Sets new standards:** The product may set new standards of its product categories and guide other similar product design in terms of quality, functions/features or style.

3. **Sets a trend:** The product design may influence people's behavior or people's inherent concept of the product around the country or even around the world. It is design may still be popular until today.

4. **Is a ground-breaking design:** The product may be a revolutionary design that may influence people’s life and production in positive aspects in terms of its technology or manufacturing techniques used during its production.

5. **Is innovative:** The product may be new and original when it was created.

6. **Improves on the past:** The product may be more refined than its previous versions.

7. **Has its place in history, or even helps change history:** The product may be irreplaceable in history and may promote the historical development of that kind of product.

#### 5.4 Visual Design Elements Checklist

Explicit Design Elements	Implicit Design Elements
Form elements	Brand values
Detail treatments	Brand heritage
Materials	Brand attributes
Colors	

Figure 56, Visual Design Elements Checklist

Figure 56 lists the major elements of product visual design. Based on the literature, product visual design elements that are specific for the product icon should be divided into explicit design elements and implicit design elements. This list should be used in Step 2 in the design approach. Designers should analyze the product icon by considering these visual product design elements. It also helps designers with ideas about what kinds of elements should be used in product design process.

## Explicit Design Elements

- **Form elements:** Include specific large form characters and shapes on bodies of product icons, such as lines and edges.
- **Detail treatments:** Include specific detail form and micro detail on bodies of product icons, such as large radii, small radii, and a banded metal ring.
- **Materials:** Use specific materials on product icon design.
- **Colors:** Use iconic colors on product icon design.

## Implicit Design Elements

- **Brand values:** a good quality that a company wants consumers to connect with a brand (“Brand value”, n.d.).
- **Brand heritage:** For brands, heritage can play an important role. It can strengthen an emotional connection to your audience by re-establishing this connection to the past (Brand heritage guide, 2012).
- **Brand attributes:** Also known as core values, brand attributes represent the essence of the brand. Brand attributes are a set of characteristics that identify the physical, character and personality traits of the brand, similar to the attributes that allow us to consistently identify individuals (“Brand attributes”, n.d.).

## 5.5 Significance of Explicit Design Elements

Designers should distinguish the significance of explicit design elements after analyzing the product icon. This step aims to separate the explicit design elements into primary explicit design elements and secondary explicit design elements. Designers could distinguish explicit design

elements by checking the product category checklist. They also could distribute the survey to people they want to get some suggestion from and analyze the data. The primary explicit design elements should be first considered when designing a product. However, secondary explicit design elements could be selectively used in the product design process.

### 5.5.1 Product Category Checklist

Product Category	The Priority of Explicit Design Elements
Home Appliances	Detail treatments, Form elements
Grills	Form elements, Detail treatments
Kitchenware	Form elements, Detail treatments
Office Supplies	Detail treatments, Form elements
Lamps	Form elements, Detail treatments, Materials
Musical Instruments	Form elements, Detail treatments
Headphones	Form elements, Detail treatments
Watches	Form elements, Detail treatments, Materials
Tools	Detail treatments, Form elements, Colors
Toys	Form elements, Detail treatments
Other	Form elements, Detail treatments

Figure 57, Product Category Checklist

According to the result of this study's product icon definition survey, the priority of explicit design elements is different among these product categories (Figure 57). In the product icon survey, overall appearance, form (details), materials, and colors are used in Question 5 that asked participants to scale the importance of an iconic product. The overall appearance in the survey is defined as a combination of the number of specific form elements used and includes specific large form characters and shapes on bodies of product icons. The form (details) is defined as the number of specific detail treatments used on a product icon. Materials and colors are specific materials and colors that are used on a product icon. Therefore, the product category checklist continues to use form elements and detail treatments (as in the visual design elements checklist) to maintain consistency in description. Other products that do not belong to any categories in the figure could follow the result for all iconic products in the survey drawing priority from form elements and detail treatments. The priority of explicit design elements for each product category in the figure is in order. For example, for lamps, the priority orders for explicit design elements are form elements, detail treatments, and materials. The explicit design elements that are not mentioned in each product category should belong to the secondary explicit design elements and will be selectively applied in the process of product design.

## 5.5.2 Explicit Design Elements Survey

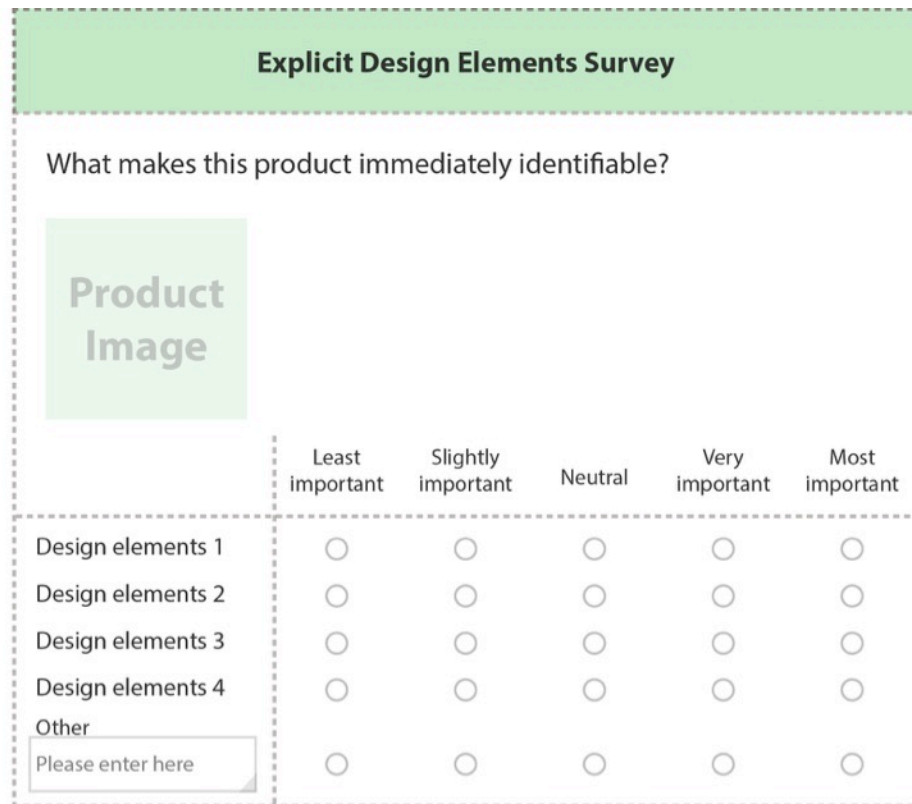

The survey form is titled "Explicit Design Elements Survey" in a green header. Below the header, the question "What makes this product immediately identifiable?" is displayed. To the left of the question is a placeholder box labeled "Product Image". To the right of the question is a Likert scale with five options: "Least important", "Slightly important", "Neutral", "Very important", and "Most important". Below the question and scale is a table with five rows: "Design elements 1", "Design elements 2", "Design elements 3", "Design elements 4", and "Other". Each row has a radio button under each of the five scale options. Below the "Other" row is a text input field with the placeholder text "Please enter here".

	Least important	Slightly important	Neutral	Very important	Most important
Design elements 1	<input type="radio"/>	<input type="radio"/>	<input type="radio"/>	<input type="radio"/>	<input type="radio"/>
Design elements 2	<input type="radio"/>	<input type="radio"/>	<input type="radio"/>	<input type="radio"/>	<input type="radio"/>
Design elements 3	<input type="radio"/>	<input type="radio"/>	<input type="radio"/>	<input type="radio"/>	<input type="radio"/>
Design elements 4	<input type="radio"/>	<input type="radio"/>	<input type="radio"/>	<input type="radio"/>	<input type="radio"/>
Other Please enter here	<input type="radio"/>	<input type="radio"/>	<input type="radio"/>	<input type="radio"/>	<input type="radio"/>

Figure 58, Explicit Design Elements Survey

In addition, designers can also distribute a survey to people they want to get suggestions from and find the priority of explicit design elements of a product icon. Figure 58 shows an explicit design elements survey. Designers should provide a clear image of the product icon, and place each explicit design element on the design element part. After that, they can collect viewpoints from different people, such as design manager, design engineer, and consumers. Finally, designers may generate ideas about the priority of explicit design elements of the product icon by analyzing the data collection. The elements that have the most votes as most important may be the primary explicit design elements.

## 5.6 Product Line Expansion Approach Checklist

Explicit Design Elements	Product Line Expanding Approach
Form elements Detail treatments	Scaling and Capacity
Form elements Detail treatments	Structure and Proportion
Colors Materials	Color Palette (Product Extension, Palette Extension)
Form elements Detail treatments Colors	Repetition

Figure 59, Product Line Expansion Approach Checklist

The product line expansion approach checklist that is summarized from the case studies may be used in the first step of designing products process (Figure 59). Selecting approaches before truly designing the products could give designers a clear direction to do the design. Designers could use one or several approaches provided from the checklist to expand product lines according to types of visual design elements that are extracted from a product icon. They should focus on designing these specific design elements when applying them on the product design. Designers also could use other approaches they want to expand a product line. It should be noted that product category could determine expansion approach. Thus, the product line expansion approach should be used depending on the situation. After deciding the product line expansion approach, designers could start to design products.

- **Scale and Capacity:** To expand a product line by scaling up and down the size of form elements and detail treatments.

- **Structure and Proportions:** To expand a product line by using a similar structure and proportions of form elements and detail treatments that extract from a product icon.
- **Color Palette (Product Extension):** To expand a product line by using existing colors and materials that are extracted from a product icon.
- **Color Palette (Palette Extension):** To expand a product line by expanding colors on an existing product icon.
- **Repetition:** To expand a product line by using repetitive design elements that are extracted from a product icon, including form elements, detail treatments, and colors.

## 5.7 Conclusion

This design approach will provide designers a method to transform a product icon into product lines. The approach can aid designers to use a product icon efficiently by analyzing specific visual design elements from a product icon. Utilizing visual design elements that are specific for a product icon to design products with a consistent and distinctive appearance can help a company and a brand differentiate in the market.

A design project using this design approach will be provided in Chapter 6. There are several benefits when using this design approach:

- **User-friendly:** Using steps describing in this design approach is clear and easy to understand. Each step is provided with checklists or survey, which is convenient for designers to use.
- **Flexible:** Methods of prioritizing explicit design elements of the product icon are



flexible, so designers could choose to check the product category checklist, collect different viewpoints from other people or use these two methods together. In addition, using this product line expansion approach to design product lines is also flexible. Designers can have their own product line expansion approach to better serve different purposes of design projects.

- Focus on expanding product lines from a product icon.
- Good for different categories of design projects.
- Good for people other than designers to use, such as product managers and product engineers.

## Chapter 6

### The Application of the Approach

#### 6.1 Introduction

This chapter will focus on providing an example of the design approach for transforming a product icon into a product line. By defining a product as an icon and analyzing explicit design elements of the product, the expected outcome can be a product line that keeps the design consistency of the brand. This product design development process will follow the design approach for designing product lines using the product icon analysis that was created according to previous research in this thesis.

#### 6.2 Step 1: Product Icon Checklist



Figure 60, Swingline 747 Business Stapler (Amazon, 2005b)

**Product Icon Checklist**

The **Primary** Factors

- Is recognizable and memorable
- Stands the test of time

The **Secondary** Factors

- Is aesthetically pleasing
- Sets new standards
- Sets a trend
- Is a ground-breaking design
- Is innovative
- Improves on the past
- Has its place in history, or even helps change history

Figure 61, Product Icon Checklist for Swingline 747 Business Stapler

Swingline is a brand famous for staplers that was founded in 1925. It created the first top-opening stapler in 1939. In 1968, the Swingline 747 was introduced, which is the most popular stapler of Swingline, and is still produced until today. The design of this stapler has stood the test of time, set a trend, and has forged its place in history. Its form is also innovative and improves on the past. There are two different models of Swingline 747, including the business version and classic version. The business version will be used in this design process. Swingline 747 business stapler has different color versions. The red version was launched in 1999 and became popular because of the hit comedy movie *Office Space*. The Swingline 747 business stapler has a smooth form and a streamlined body that makes it aesthetically pleasing and also recognizable and

memorable. This product meets all primary factors and some secondary factors on the checklist. Therefore, Swingline 747 business stapler is a product icon.

**6.3 Step 2: Visual Design Elements Checklist**

Explicit Design Elements	Implicit Design Elements
Form elements	Brand values
Detail treatments	Brand heritage
Materials	Brand attributes
Colors	

Figure 62, Visual Design Elements Related to Swingline 747 Business Stapler

The Swingline 747 business stapler has some specific visual design elements that can be analyzed according to the visual design elements checklist. Explicit design elements contain specific form elements and detail treatments. For implicit design elements, the brand value of Swingline is quality, innovation, and reliability.

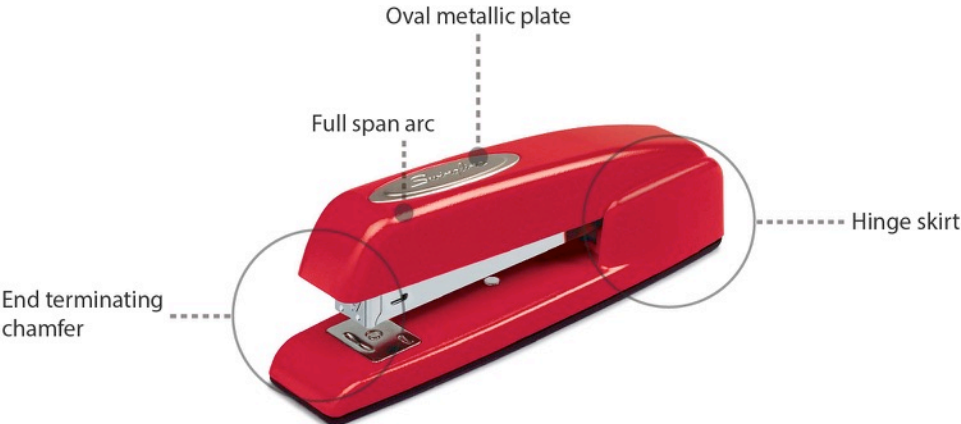

Figure 63, Explicit Design Elements of Swingline 747 Business Stapler

The Swingline 747 business stapler is made of metal that has several specific explicit design elements (Figure 63). The full span arc with a radius is a distinctive large form on the stapler. It belongs to *Form Elements* on the visual design elements checklist. Moreover, several detail treatments are unique for this stapler, including an end terminating chamfer, hinge skirt, and oval metallic plate. Those explicit design elements make the Swingline 747 business stapler distinctive and recognizable. Moreover, the end terminating chamfer and hinge skirt could be interpreted as solid, which refers to the brand value of good quality and reliability. Its end terminating chamfer can also be interpreted as creative, which refers to the brand value of innovation.

#### 6.4 Step 3: Significance of Explicit Design Elements

Product Category	The Priority of Explicit Design Elements
Home Appliances	Detail treatments, Form elements
Grills	Form elements, Detail treatments
Kitchenware	Form elements, Detail treatments
Office Supplies	Detail treatments, Form elements
Lamps	Form elements, Detail treatments, Materials
Musical Instruments	Form elements, Detail treatments
Headphones	Form elements, Detail treatments
Watches	Form elements, Detail treatments, Materials
Tools	Detail treatments, Form elements, Colors
Toys	Form elements, Detail treatments
Other	Form elements, Detail treatments

Figure 64, Checked the Priority of Explicit Design Elements in Product Category Checklist

Swingline is a brand that mainly produces office supplies. However, most existing product designs in its product lines are similar to their competitors in the market. Thus, to use the visual design elements from its product icon to design products may help this brand to differentiate in office products. By checking the product category checklist, the primary explicit design elements for office products should be detail treatments and form elements. At the same time, the priority should be detail treatment, and then form elements. There are no secondary explicit design elements for this product.

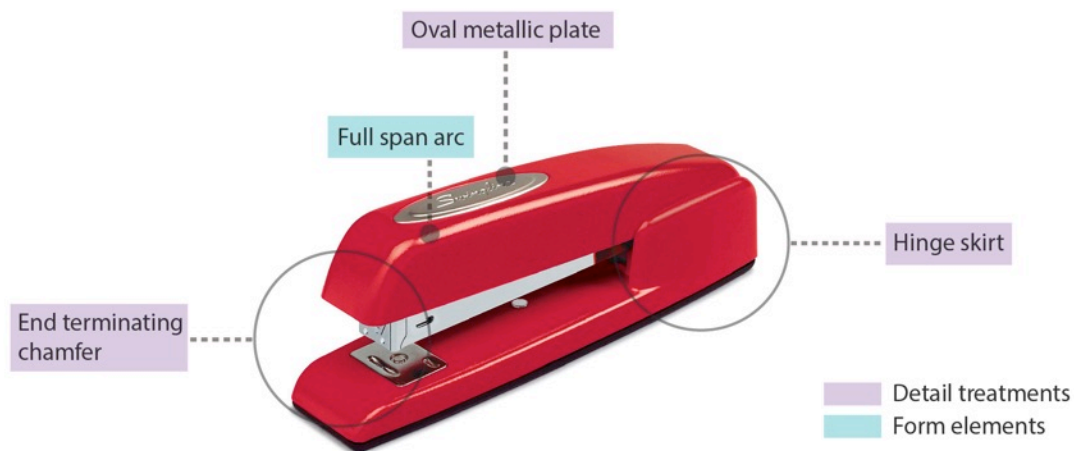

Figure 65, The Priority of Explicit Design Elements of Swingline 747 Business Stapler

As Figure 65 shows, on the Swingline 747 business stapler detail treatments, purple highlights are the number one primary explicit design elements, including an end terminating chamfer, oval metallic plate, and hinge skirt. The primary explicit design element, the full span arc, is part of the form elements. These primary explicit design elements should be considered first when designing products. Moreover, detail treatments are the top priority among these primary explicit design elements.

## 6.5 Step 4: Design Products

### Product Line Expansion Approach Checklist

Explicit Design Elements	Product Line Expanding Approach
Form elements Detail treatments	Scaling and Capacity
Form elements Detail treatments	Structure and Proportion
Colors Materials	Color Palette (Product Extension, Palette Extension)
Form elements Detail treatments Colors	Repetition

Figure 66, Checked the Product Line Expansion Approach Checklist

Scaling and capacity and repetition will be used to expand the new product line. The specific detail treatments and form elements of the Swingline 747 business stapler will apply to the design of the new product.

## Design Concepts

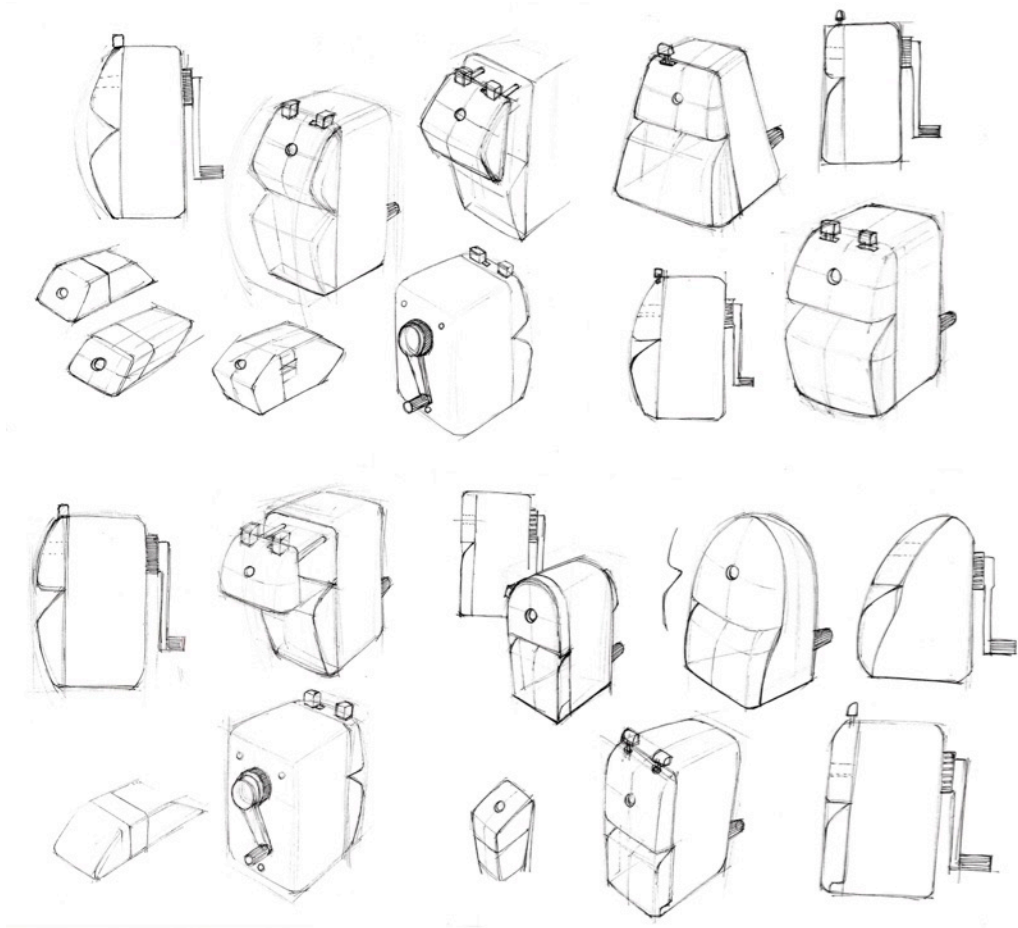

Figure 67, Idea Collection

According to the analysis of visual design elements, sketches of initial design concepts are shown in Figure 67.



## Concepts Refinement

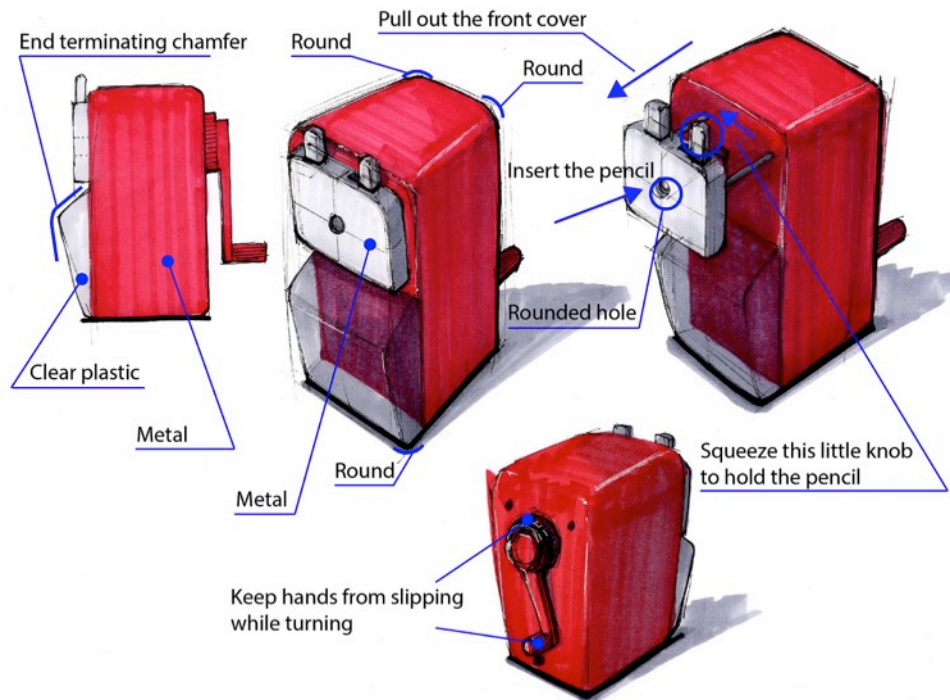

Figure 68, Swingline Manual Pencil Sharpener Concept 1

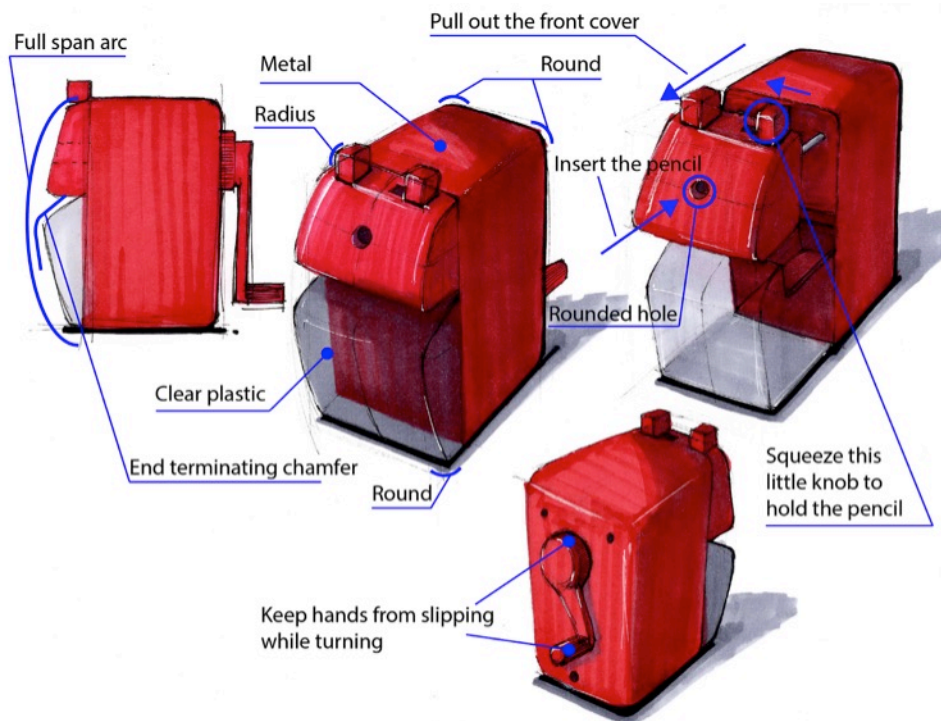

Figure 69, Swingline Manual Pencil Sharpener Concept 2

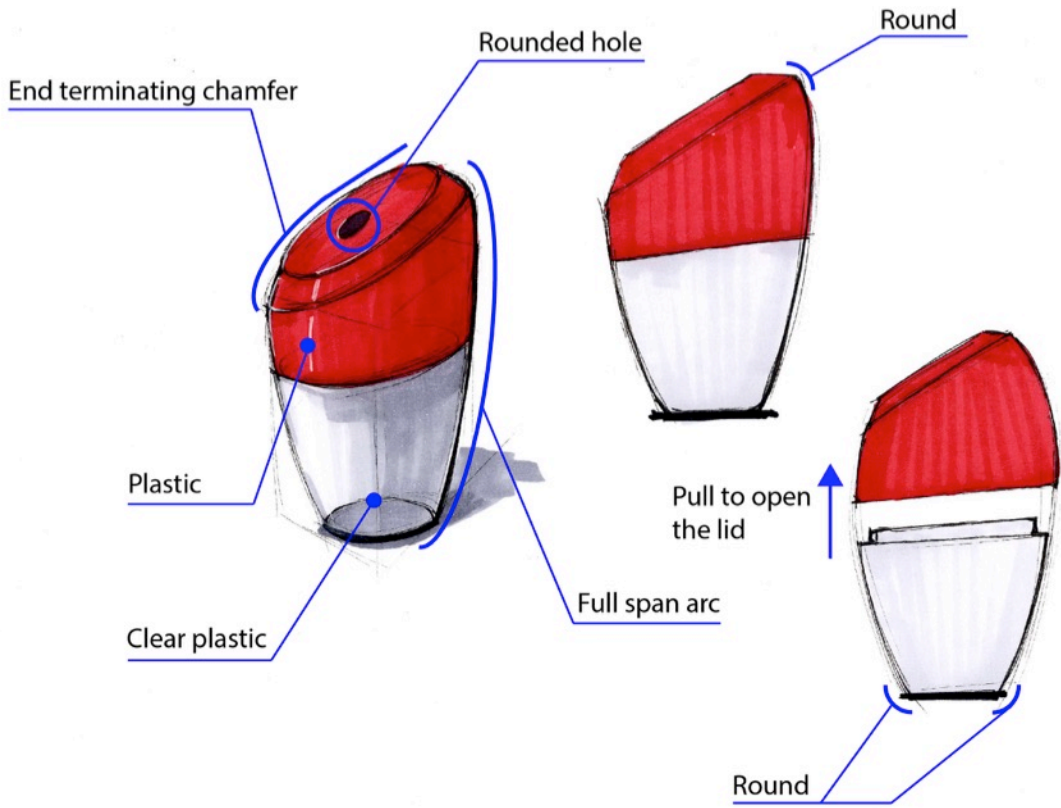

Figure 70, Swingline Hand Held Pencil Sharpener Concept 1

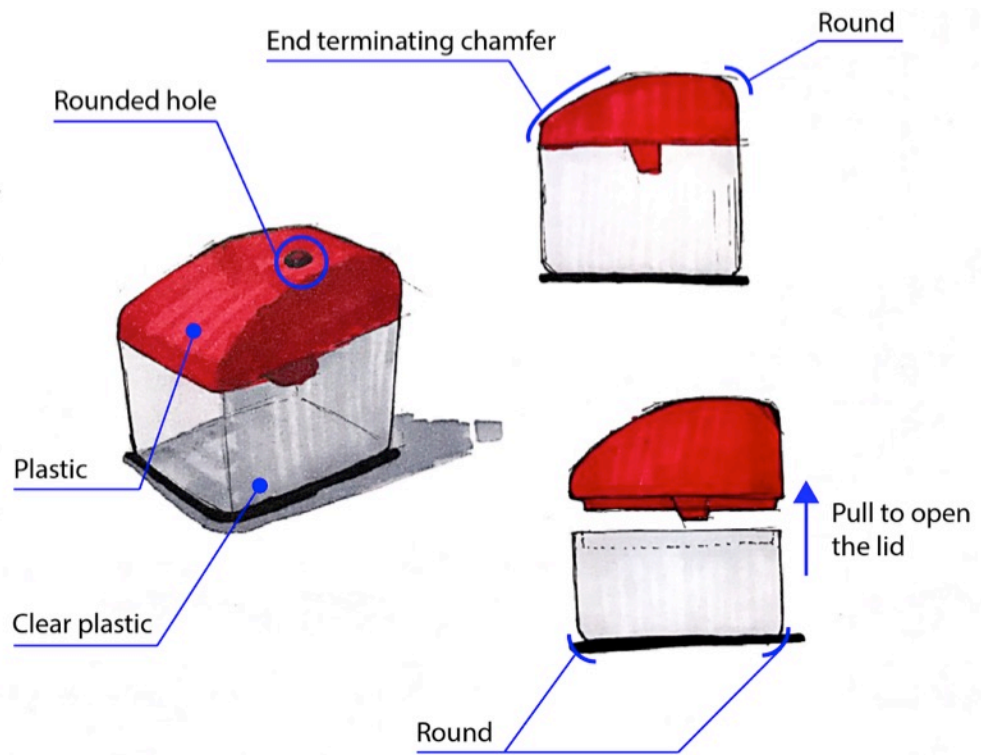

Figure 71, Swingline Hand Held Pencil Sharpener Concept 2

Figure 68 to Figure 71 are the refinement of concepts selected and further developed from the initial concepts. Each concept applies some primary explicit design elements of the Swingline 747 business stapler.

### Possible Design Solution

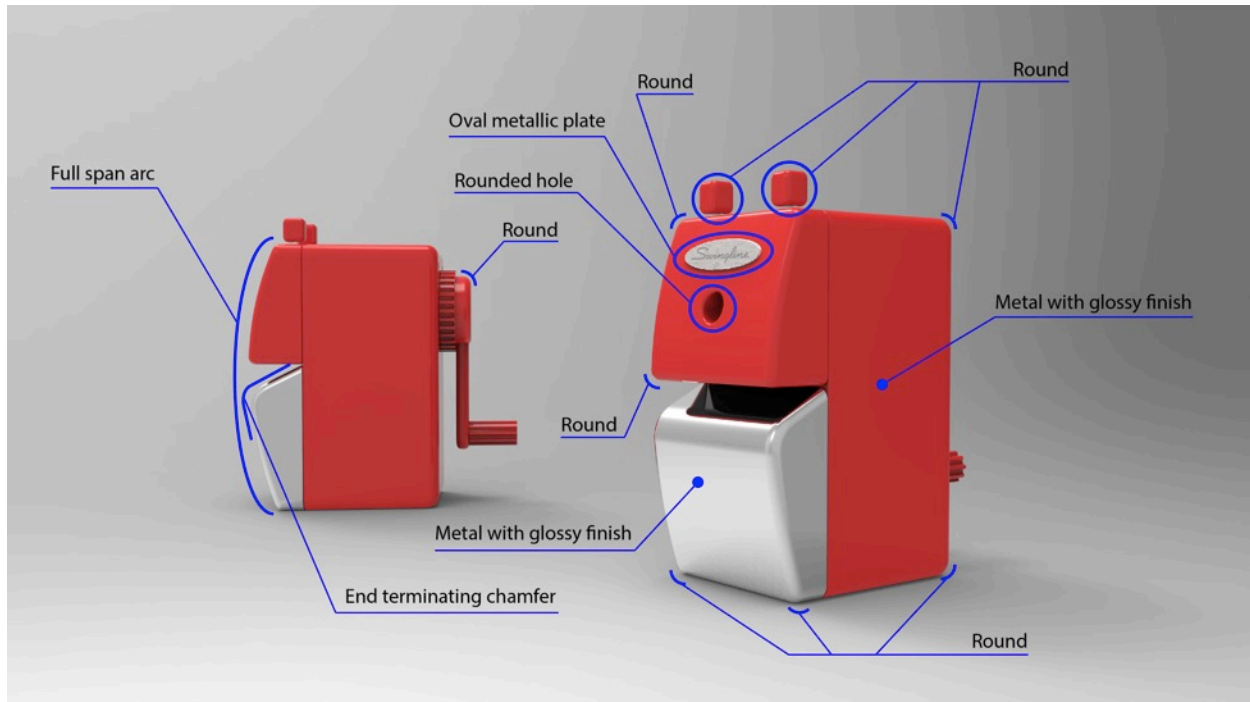

Figure 72, Swingline Manual Pencil Sharpener

Figure 72 shows the final design of Swingline manual pencil sharpener that was developed from Concept 1. This is a design that shares some visual design elements of the Swingline 747 business stapler by using scaling and capacity and repetition approaches. Some of the explicit elements from the product icon are scaled up or down in this pencil sharpener design. For example, the full span arc has been scaled down to meet the need of design while the end terminating chamfer keeps the same angle as the product icon. In addition to the form elements and detail treatments from the above analysis, rounded edges and materials are applied to the design of manual pencil sharpener in order keep the visual consistency of the stapler.

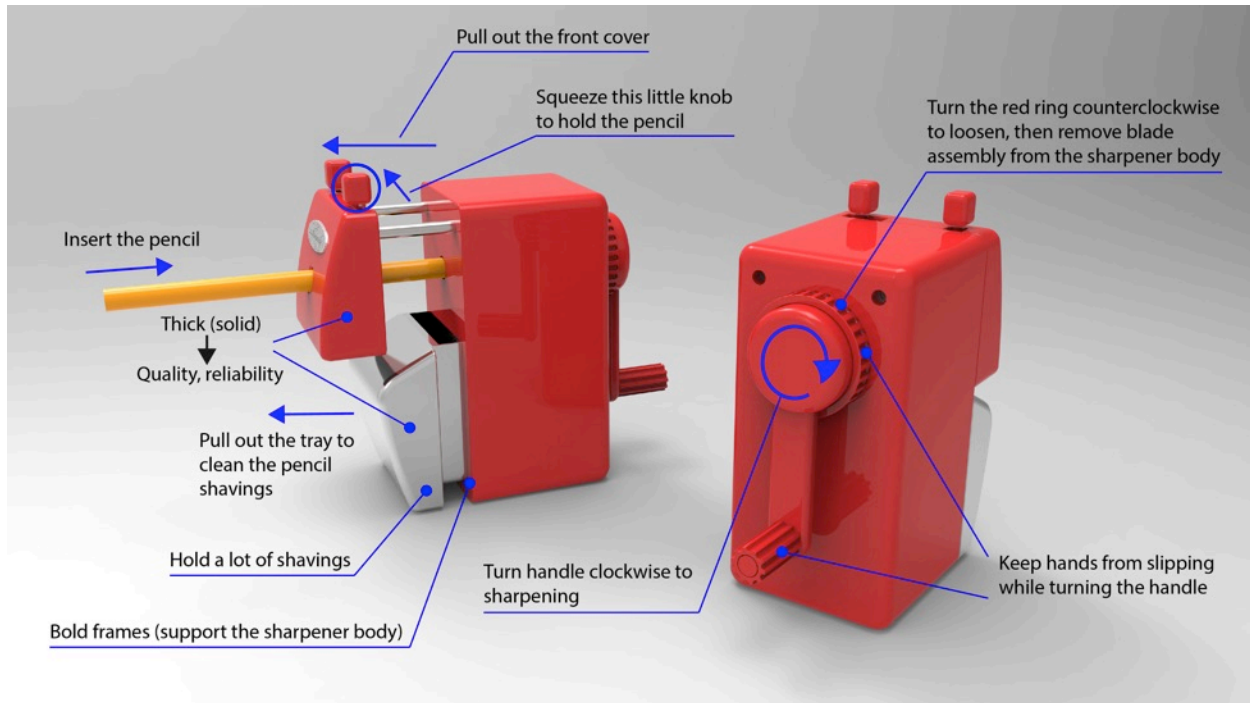

Figure 73, Swingline Manual Pencil Sharpener

There are several steps to use this Swingline manual pencil sharpener (Figure 73). To pull out the front cover is the first step. Second, squeeze the little knob that is used to hold the pencil, and insert the pencil. Then turn the handle clockwise to sharpen. The concave-convex texture on the handle designs for keeping hands from slipping while turning. If a lead breaks off inside the sharpener, turn the red ring counterclockwise to loosen the handle and then remove blade assembly from the sharpener body to clean the blade.

The bold frames that are designed for supporting the sharpener body will appear when pulling out the tray. The front cover and the tray that can hold a lot of shavings are designed with some thickness that may be interpreted as solid, which refers to the brand value of quality and reliability.

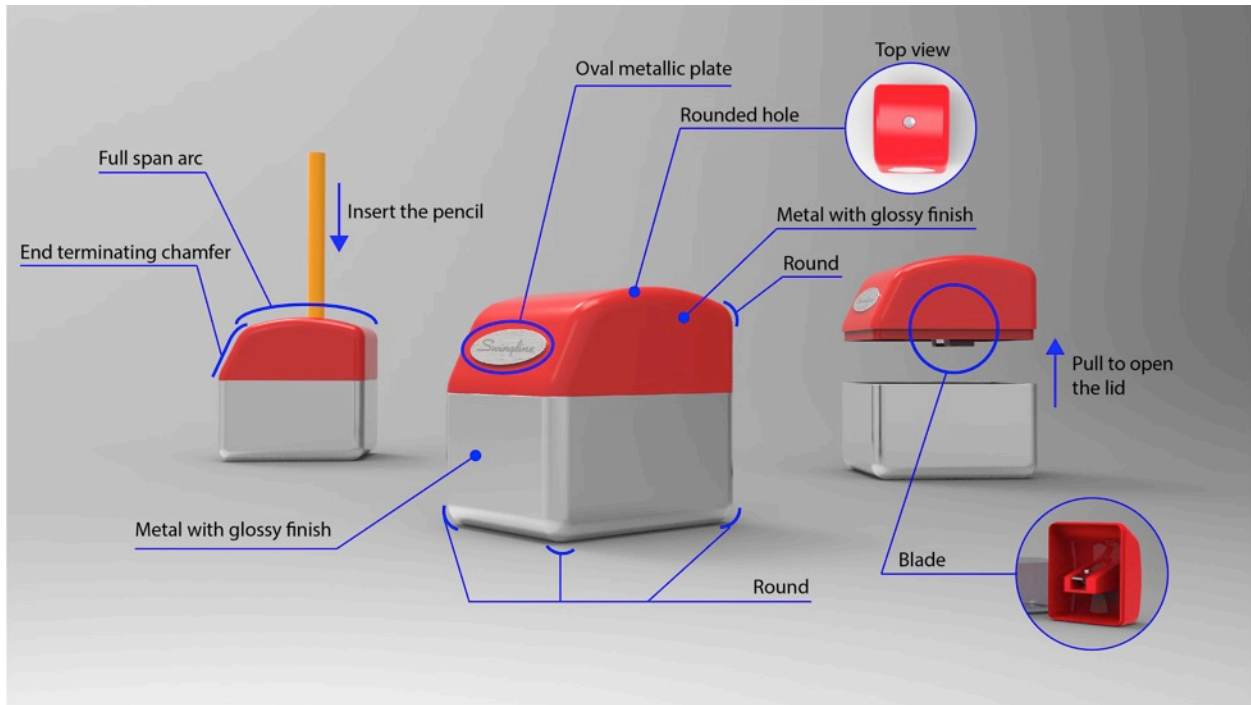

Figure 74, Swingline Hand Held Pencil Sharpener

This is a Swingline hand held pencil sharpener design that applied primary explicit design elements from the Swingline 747 business stapler including the oval metallic plate, the full span arc, and the end terminating chamfer. The materials and rounded edges are also extracted from the product icon, which gives the product design a consistent appearance. Meanwhile, the cubic product form combined with the end terminating chamfer may be interpreted as solid, which refers to the brand value of reliability.

In summary, these two pencil sharpeners are designed to combine with explicit and implicit design elements from the product icon. In addition, some explicit design elements on the product design help communicate implicit design elements.

## 6.6 Step 5: Finalize Product Lines



Figure 75, Swingline 747 Business Stapler (Amazon, 2005b)



Figure 76, Swingline Pencil Sharpener Product Line

According to the visual design elements analysis of the Swingline 747 business stapler, a Swingline pencil sharpener product line has been created. Most specific visual design elements are applied through this product line consistently. The design consistency may help the brand clearly differentiate from their competitors and strengthen their position in the market.

## **Chapter 7**

### **Conclusion and Further Development**

#### **7.1 Conclusion**

This thesis aims to develop an approach that contributes to transforming a product icon into product lines. The purpose of the approach is to help designers and companies verify a product is an icon, and analyze the specific visual design elements of the product icon. Utilizing the specific visual design elements properly on product design may help designers and companies to create a recognizable and distinctive brand.

The results of the literature review study show that visual design elements are very important for product design, and can be divided into explicit design elements and implicit design elements. Explicit design elements can be found from the physical features of product design, including form elements, detail treatments, materials, and colors. Implicit design elements are carried through to additional designs include: brand value, brand heritage, and brand attributes. In addition, explicit design elements can help communicate implicit design elements. Furthermore, the results of product icon survey show how to define a product as an icon and the priority of explicit design elements for different product categories. Moreover, several product lines expansion approaches have been found from case studies. Thus, based on these studies, the design approach has been created. The sample of work is designed to demonstrate the application of the approach.

## **7.2 Further Development**

There are more aspects that can be further investigated in the next phase. Suggestions for further research are as follows:

1. This thesis only focuses on studying visual design elements of product icons, but designers could further develop the approach for other design elements of human senses, such as auditory, tactile, and olfactory.

2. These checklists provide designers with a choice beyond the existing design approach. As time progresses, some checklists including product category checklist and product line expansion approach checklist could be improved by feedback from other designers and consumers, or studies from other product icon cases.

3. Among these explicit design elements of product icon, research could be done to determine how to weight their importance for applying them on product line designs of different categories.



## References

- Albus, V., Kras, R., Woodham, J.M., Bosomworth, D., Breward, C., Fischer, V., . . . Zukowsky, J. (2000). *Icons of design! : the 20<sup>th</sup> century*. Munich : Prestel Verlag.
- Amazon. (2005a). The Bodum Coffee Maker. Retrieved from <https://www.amazon.com/Bodum-3020-16US-Chambord-Coffee-Press/dp/B00005LM0S>
- Amazon. (2005b). Swingline 747 Business Stapler. Retrieved from [https://www.amazon.com/Swingline-Stapler-Capacity-Business-Desktop/dp/B0006HUQZ6/ref=sr\\_1\\_2?ie=UTF8&qid=1509143725&sr=8-2&keywords=swingline+stapler+747](https://www.amazon.com/Swingline-Stapler-Capacity-Business-Desktop/dp/B0006HUQZ6/ref=sr_1_2?ie=UTF8&qid=1509143725&sr=8-2&keywords=swingline+stapler+747)
- Amazon. (2002). The KitchenAid Stand Mixer. Retrieved from [https://www.amazon.com/KitchenAid-KSM150P5ER-Artisan-Tilt-Head-Pouring/dp/B00005UP2P/ref=sr\\_1\\_5?s=kitchen&ie=UTF8&qid=1506292103&sr=1-5&keywords=KitchenAid+stand+mixer](https://www.amazon.com/KitchenAid-KSM150P5ER-Artisan-Tilt-Head-Pouring/dp/B00005UP2P/ref=sr_1_5?s=kitchen&ie=UTF8&qid=1506292103&sr=1-5&keywords=KitchenAid+stand+mixer)
- Autoblog. (n.d.a). 2014 Volvo S60. Retrieved from <https://www.autoblog.com/buy/2014-Volvo-S60/photos/#slide-109>
- Autoblog. (n.d.b). 2007 Volvo S60. Retrieved from <https://www.autoblog.com/buy/2007-Volvo-S60/photos/#slide-109>
- Anglepoise. (n.d.a). How can I date my vintage Anglepoise lamp? Retrieved from <https://www.anglepoise.com/faq/view/how-can-i-date-my-vintage-anglepoiser-lamp>
- Anglepoise. (n.d.b). Our Story. Retrieved from <https://www.anglepoise.com/about>

Anglepoise. (n.d.c). Type 75 desk lamp. Retrieved from  
<https://www.anglepoise.com/product/type-75-desk-lamp>

Anglepoise. (n.d.d). Anglepoise. Retrieved from <https://www.anglepoise.com/>

Anglepoise. (2017). Anglepoise Brochure 2017. Retrieved from  
<http://files.anglepoise.com/public/file/3lgj-itt7chnj>

Beyond Design Inc. (2012). Expressing brand through a product. *Innovation: designing understanding, Winter*, 10-13.

Beatrice Companies Inc. (n.d.). Western Electric Color Charts - Chart 1. Retrieved from  
<http://www.beatriceco.com/bti/porticus/bell/telephones-colorcharts-1.html>

Bialetti. (n.d.a). The history. Retrieved from [http://www.bialetti.it/en/the\\_brand/the\\_history.html](http://www.bialetti.it/en/the_brand/the_history.html)

Bialetti. (n.d.b). Moka Express. Retrieved from  
[http://www.bialetti.it/en/prodotto/MOKA\\_E\\_CAFFETTIERE/c0740be8-24e9-11e7-8280-28cfe918c1a7/](http://www.bialetti.it/en/prodotto/MOKA_E_CAFFETTIERE/c0740be8-24e9-11e7-8280-28cfe918c1a7/)

Bialetti. (n.d.c). Bialetti. Retrieved from <http://www.bialetti.it/en/index.html>

First Versions. (n.d.). Bialetti Moka Express. Retrieved from  
<http://www.firstversions.com/2015/02/bialetti.html>

Brand attributes. (n.d.). Retrieved from  
<http://identitystandards.illinois.edu/theillinoisstory/attributes.html>

Brand heritage guide. (2012). Retrieved from  
<https://www.slideshare.net/hungrystratgist/brand-heritage-guide>

Brand value. (n.d.). In Cambridge online dictionary. Retrieved from  
<http://dictionary.cambridge.org/us/dictionary/english/brand-value>

Chen, K., & Owen, C. L. (1997). Form Language and Style. *Design Studies*, 18, 249-274.

- Creusen, M. E., & Schoormans, J. P. (2005). The different roles of product appearance in consumer choice. *Journal of product innovation management*, 22(1), 63-81.
- The Design Museum. (2014). Anglepoise. Retrieved from <http://designmuseum.org/design/anglepoise>
- Fiskars. (2014). *FISKARS 1649 – 365 years of Finnish Industrial History*. Raasepori, Finland: Fiskars Oyj Abp.
- Fiskars. (n.d.a). *The DNA of a design*. Helsinki, Finland: Fiskars Corporation.
- Fiskars. (n.d.b). The Original Orange-handled Scissors™ (8"). Retrieved from <http://www2.fiskars.com/Products/Crafting-and-Sewing/Scissors-and-Shears/The-Original-Orange-Handled-Scissors-8>
- Fiskars. (n.d.c). Fiskars. Retrieved from <http://www2.fiskars.com>
- Fiskars. (n.d.d). The art of doing. Retrieved from <http://www2.fiskars.com/#>
- Karjalainen, T.M. (2001). When is a car like a drink? Metaphor as A Means to Distilling Brand and Product Identity. *Design Management Journal, Winter*, 66-71.
- Karjalainen, T.M. (2002). On semantic transformation: product design elements as brand manifestations. *Proceedings of the “Common Ground” International Design Conference, London, September 5-7*.
- Karjalainen, T.M. (2003a). Strategic design language — transforming brand identity into product design elements. *Proceedings of the 10<sup>th</sup> International Product Development Management Conference, Brussels, June 10-11*.
- Karjalainen, T.M. (2003). Semantic knowledge in the creation of brand-specific product design. In *5th European Academy of Design conference*.

- Karjalainen, T.M. (2003c). Strategic Brand Identity and Symbolic Design Cues. *Proceedings of the 6<sup>th</sup> Asian Design Conference, Tsukuba, Japan, October 14-17.*
- Karjalainen, T.M. (2004). *Semantic transformation in design: Communicating strategic brand identity through product design references.* University of Art and Design Helsinki.
- Karjalainen, T.M. (2007). It looks like a Toyota: Educational Approaches to Designing for Visual Brand Recognition. *International Journal of Design, 1*(1), 67-81.
- Karjalainen, T.M., & Warell, A. (2005). Do you recognize this tea flask? Transformation of brand-specific product identity through visual design cues. *Proceedings of the International Design Congress, IASDR 2005, Douliou, Taiwan, October 31-November 4.*
- Karjalainen, T. M., & Snelders, D. (2010). Designing visual recognition for the brand. *Journal of Product Innovation Management, 27*(1), 6-22.
- Kreuzbauer, R., & Malter, A.J. (2007). Product Design Perception and Brand Categorization. *Consumer Research, 34*, 240-246.
- KitchenAid. (n.d.a). Artisan® Design Series 5 Quart Tilt-Head Stand Mixer with Glass Bowl. Retrieved from [http://www.kitchenaid.com/shop/countertop-appliances-1/countertop-appliances-2/stand-mixers-3/-\[KSM155GBCA\]-400123/KSM155GBCA/](http://www.kitchenaid.com/shop/countertop-appliances-1/countertop-appliances-2/stand-mixers-3/-[KSM155GBCA]-400123/KSM155GBCA/)
- KitchenAid. (n.d.b). KitchenAid. Retrieved from <http://www.kitchenaid.com>
- KitchenAid. (2015). The black stainless catalog. Retrieved from <http://www.kitchenaid.com/pdf/brand/resources/KitchenAid-Black-Stainless-Catalog.pdf>
- Laban, J. (2008). Anglepoise Fifty Lamp by Anthony Dickens. Retrieved from <http://www.apartmenttherapy.com/anglepoise-fifty-lamp-by-antho-44161>

- Leder, H., Carbon, C.C., & Kreuzbauer, R. (2007). Product-Design Perception and Brand Strength. *Thexis*, 2, 4-7.
- Lewis, C., Chynoweth, C., & Wyke, N. (2014). Successful modern entrepreneurship. *The Times*, Thursday November 13, 2014. Retrieved from <https://www.santander.co.uk/sites/default/files/November%202014%20-%20Innovation%20Beyond%20Start%20Up.pdf>
- Lidwell, W., & Manacsa, G. (2009). *Deconstructing product design: exploring the form, function, usability, sustainability, and commercial success of 100 amazing products*. Beverly, MA: Rockport Publishers, Inc.
- Luo, S. J., & Zhu, S.S. (2009). Ontology-based product family design DNA in industrial design. *Computer Integrated Manufacturing Systems*, 15(2), 226-233.
- Lu, Z.L., Tang, W.C., & Xue, C.Q. (2010). Method of design DNA reasoning based on shape grammar. *Journal of Southeast University (Natural Science Edition)*, 40(4), 704-711.
- Maker Inc. (2014). The maker story of kitchenAid. Retrieved from <http://stories.maker.me/the-maker-story-of-kitchenaid/>
- McCormack, J.P., Cagan, J. & Vogel, C.M. (2004). Speaking the Buick language: capturing, understanding, and exploring brand identity with shape grammars. *Design Studies*, 25, 1-29.
- Nbhdtestblog. (2012). Model 500 telephone. Retrieved from [https://nbhdtestblog.wordpress.com/2012/08/15/model\\_500\\_phone/](https://nbhdtestblog.wordpress.com/2012/08/15/model_500_phone/)
- Stompff, G. (2003). The forgotten bond: Brand identity and product design. *Design Management Journal*, 14(1), 26-32.

Warell, A. (2001). *Design syntactics: A functional approach to visual product form*. Gothenburg: Chalmers University of Technology.

Zhu, S.S., Luo, S.J., Ying, F.T., & He, J. (2010). Product family design DNA for product visual identity. *Journal of Zhejiang University (Engineering Science)*, 44(4), 715-721.

Appendix A  
The Online Survey

**INFORMATION LETTER**  
**for a Research Study entitled**  
**“Product Icon Survey”**

You are invited to participate in a research study to investigate *the definition of a product icon and the key elements that make a product iconic*. This study is being conducted by Si Luo, under the direction of associate professor Shea Tillman in the Auburn University School of Industrial and Graphic Design. You are invited to participate because you are currently working as a designer, and are age 19 or older.

If you decide to participate in this research study, you will be asked to take an anonymous online survey through Qualtrics. Your total time commitment will be approximately 5-7 minutes.

Your participation in this study is completely anonymous and voluntary. There are no foreseeable risks associated with this study. However, if you feel uncomfortable answering any questions, you can withdraw from the survey at any time by closing your browser window. Once you've submitted anonymous data, it cannot be withdrawn since it will be unidentifiable. Your decision about whether or not to participate will not jeopardize your future relations with the School of Industrial and Graphic Design and Auburn University.

Information collected through your participation may be used for publication or professional presentation.

If you have any questions about this study, please ask them now or contact Si Luo at [szl0085@auburn.edu](mailto:szl0085@auburn.edu), or Shea Tillman at [tillmts@auburn.edu](mailto:tillmts@auburn.edu).

If you have questions about your rights as a research participant, you may contact the Auburn University Office of Human Subjects Research or the Institutional Review Board by phone (334)-844-5966 or e-mail at [IRBAdmin@auburn.edu](mailto:IRBAdmin@auburn.edu) or [IRBChair@auburn.edu](mailto:IRBChair@auburn.edu).

HAVING READ THE INFORMATION PROVIDED, YOU MUST DECIDE IF YOU WANT TO PARTICIPATE IN THIS RESEARCH PROJECT. IF YOU DECIDE TO PARTICIPATE, THE DATA YOU PROVIDE WILL SERVE AS YOUR AGREEMENT TO DO SO. THIS LETTER IS YOURS TO KEEP.

***The Auburn University Institutional Review Board has approved this document for use from February 20, 2017 to February 19, 2020. Protocol #16-434 EX 1702***



What is your primary area of expertise?

- Product designer
  - Graphic designer
  - Exhibit/Event designer
  - UX/UI designer
  - Design engineer
  - Marketing/Brand manager
  - Architect
  - Interior designer
  - Other
- 

Years of experience.

- 1-5
- 6-10
- 11-15
- 16-30
- More than 30















In your opinion, what most establishes a product as an icon?

	Least important	Slightly important	Neutral	Very important	Most important
Sets a benchmark for others to follow.	<input type="radio"/>	<input type="radio"/>	<input type="radio"/>	<input type="radio"/>	<input type="radio"/>
Is a ground breaking design.	<input type="radio"/>	<input type="radio"/>	<input type="radio"/>	<input type="radio"/>	<input type="radio"/>
Improves on the past.	<input type="radio"/>	<input type="radio"/>	<input type="radio"/>	<input type="radio"/>	<input type="radio"/>
Sets new standards.	<input type="radio"/>	<input type="radio"/>	<input type="radio"/>	<input type="radio"/>	<input type="radio"/>
Stands the test of time.	<input type="radio"/>	<input type="radio"/>	<input type="radio"/>	<input type="radio"/>	<input type="radio"/>
Stays in the memory of who see/use it.	<input type="radio"/>	<input type="radio"/>	<input type="radio"/>	<input type="radio"/>	<input type="radio"/>
Is often recognized immediately by consumers.	<input type="radio"/>	<input type="radio"/>	<input type="radio"/>	<input type="radio"/>	<input type="radio"/>
Inspires other designers.	<input type="radio"/>	<input type="radio"/>	<input type="radio"/>	<input type="radio"/>	<input type="radio"/>
Sets a trend.	<input type="radio"/>	<input type="radio"/>	<input type="radio"/>	<input type="radio"/>	<input type="radio"/>
Is innovative.	<input type="radio"/>	<input type="radio"/>	<input type="radio"/>	<input type="radio"/>	<input type="radio"/>
Is aesthetically pleasing.	<input type="radio"/>	<input type="radio"/>	<input type="radio"/>	<input type="radio"/>	<input type="radio"/>
Is often emulated/copied by other designers.	<input type="radio"/>	<input type="radio"/>	<input type="radio"/>	<input type="radio"/>	<input type="radio"/>
Has its place in history, or even helps change history.	<input type="radio"/>	<input type="radio"/>	<input type="radio"/>	<input type="radio"/>	<input type="radio"/>
Enter another option <input type="text"/>	<input type="radio"/>	<input type="radio"/>	<input type="radio"/>	<input type="radio"/>	<input type="radio"/>

Enter another option

---

Choose three products you consider the most iconic.

- |   |  |  |  |   |
|---|--|--|--|---|
| <input type="checkbox"/> <br>Swatch Watch        | <input type="checkbox"/> <br>Beats Headphone    | <input type="checkbox"/> <br>Weber Grill          | <input type="checkbox"/> <br>Scotch Tape             | <input type="checkbox"/> <br>Dewalt Drill      |
| <input type="checkbox"/> <br>Maglite Flashlight | <input type="checkbox"/> <br>Victorinox Knives | <input type="checkbox"/> <br>Stratocaster Guitar | <input type="checkbox"/> <br>KitchenAid Stand mixer | <input type="checkbox"/> <br>LAMY Pen        |
| <input type="checkbox"/> <br>Fiskars Scissors  | <input type="checkbox"/> <br>Lego             | <input type="checkbox"/> <br>Bodum Coffee maker | <input type="checkbox"/> <br>Le creuset Pot        | <input type="checkbox"/> <br>Anglepoise Lamp |

Display This Question:

If Choose three products you consider the most iconic. = Swatch Watch

What makes this product immediately identifiable?



	Least important	Slightly important	Neutral	Very important	Most important
Form (details)	<input type="radio"/>	<input type="radio"/>	<input type="radio"/>	<input type="radio"/>	<input type="radio"/>
Materials	<input type="radio"/>	<input type="radio"/>	<input type="radio"/>	<input type="radio"/>	<input type="radio"/>
Colors	<input type="radio"/>	<input type="radio"/>	<input type="radio"/>	<input type="radio"/>	<input type="radio"/>
Overall Appearance	<input type="radio"/>	<input type="radio"/>	<input type="radio"/>	<input type="radio"/>	<input type="radio"/>
Other <input type="text"/>	<input type="radio"/>	<input type="radio"/>	<input type="radio"/>	<input type="radio"/>	<input type="radio"/>

-----

Display This Question:

If Choose three products you consider the most iconic. = Bodum Coffee maker

What makes this product immediately identifiable?



	Least important	Slightly important	Neutral	Very important	Most important
Form (details)	<input type="radio"/>	<input type="radio"/>	<input type="radio"/>	<input type="radio"/>	<input type="radio"/>
Materials	<input type="radio"/>	<input type="radio"/>	<input type="radio"/>	<input type="radio"/>	<input type="radio"/>
Colors	<input type="radio"/>	<input type="radio"/>	<input type="radio"/>	<input type="radio"/>	<input type="radio"/>
Overall Appearance	<input type="radio"/>	<input type="radio"/>	<input type="radio"/>	<input type="radio"/>	<input type="radio"/>
Other <input type="text"/>	<input type="radio"/>	<input type="radio"/>	<input type="radio"/>	<input type="radio"/>	<input type="radio"/>

-----

Display This Question:

If Choose three products you consider the most iconic. = Maglite Flashlight

What makes this product immediately identifiable?



	Least important	Slightly important	Neutral	Very important	Most important
Form (details)	<input type="radio"/>	<input type="radio"/>	<input type="radio"/>	<input type="radio"/>	<input type="radio"/>
Materials	<input type="radio"/>	<input type="radio"/>	<input type="radio"/>	<input type="radio"/>	<input type="radio"/>
Colors	<input type="radio"/>	<input type="radio"/>	<input type="radio"/>	<input type="radio"/>	<input type="radio"/>
Overall Appearance	<input type="radio"/>	<input type="radio"/>	<input type="radio"/>	<input type="radio"/>	<input type="radio"/>
Other <input type="text"/>	<input type="radio"/>	<input type="radio"/>	<input type="radio"/>	<input type="radio"/>	<input type="radio"/>

-----

Display This Question:

If Choose three products you consider the most iconic. = LAMY Pen

What makes this product immediately identifiable?



	Least important	Slightly important	Neutral	Very important	Most important
Form (details)	<input type="radio"/>	<input type="radio"/>	<input type="radio"/>	<input type="radio"/>	<input type="radio"/>
Materials	<input type="radio"/>	<input type="radio"/>	<input type="radio"/>	<input type="radio"/>	<input type="radio"/>
Colors	<input type="radio"/>	<input type="radio"/>	<input type="radio"/>	<input type="radio"/>	<input type="radio"/>
Overall Appearance	<input type="radio"/>	<input type="radio"/>	<input type="radio"/>	<input type="radio"/>	<input type="radio"/>
Other <input type="text"/>	<input type="radio"/>	<input type="radio"/>	<input type="radio"/>	<input type="radio"/>	<input type="radio"/>

-----

Display This Question:

If Choose three products you consider the most iconic. = Le creuset Pot

What makes this product immediately identifiable?



	Least important	Slightly important	Neutral	Very important	Most important
Form (details)	<input type="radio"/>	<input type="radio"/>	<input type="radio"/>	<input type="radio"/>	<input type="radio"/>
Materials	<input type="radio"/>	<input type="radio"/>	<input type="radio"/>	<input type="radio"/>	<input type="radio"/>
Colors	<input type="radio"/>	<input type="radio"/>	<input type="radio"/>	<input type="radio"/>	<input type="radio"/>
Overall Appearance	<input type="radio"/>	<input type="radio"/>	<input type="radio"/>	<input type="radio"/>	<input type="radio"/>
Other	<input type="radio"/>	<input type="radio"/>	<input type="radio"/>	<input type="radio"/>	<input type="radio"/>
<input type="text"/>	<input type="radio"/>	<input type="radio"/>	<input type="radio"/>	<input type="radio"/>	<input type="radio"/>



Display This Question:

If Choose three products you consider the most iconic. = Beats Headphone

What makes this product immediately identifiable?



	Least important	Slightly important	Neutral	Very important	Most important
Form (details)	<input type="radio"/>	<input type="radio"/>	<input type="radio"/>	<input type="radio"/>	<input type="radio"/>
Materials	<input type="radio"/>	<input type="radio"/>	<input type="radio"/>	<input type="radio"/>	<input type="radio"/>
Colors	<input type="radio"/>	<input type="radio"/>	<input type="radio"/>	<input type="radio"/>	<input type="radio"/>
Overall Appearance	<input type="radio"/>	<input type="radio"/>	<input type="radio"/>	<input type="radio"/>	<input type="radio"/>
Other <input type="text"/>	<input type="radio"/>	<input type="radio"/>	<input type="radio"/>	<input type="radio"/>	<input type="radio"/>

-----

Display This Question:

If Choose three products you consider the most iconic. = Dewalt Drill

What makes this product immediately identifiable?



	Least important	Slightly important	Neutral	Very important	Most important
Form (details)	<input type="radio"/>	<input type="radio"/>	<input type="radio"/>	<input type="radio"/>	<input type="radio"/>
Materials	<input type="radio"/>	<input type="radio"/>	<input type="radio"/>	<input type="radio"/>	<input type="radio"/>
Colors	<input type="radio"/>	<input type="radio"/>	<input type="radio"/>	<input type="radio"/>	<input type="radio"/>
Overall Appearance	<input type="radio"/>	<input type="radio"/>	<input type="radio"/>	<input type="radio"/>	<input type="radio"/>
Other	<input type="radio"/>	<input type="radio"/>	<input type="radio"/>	<input type="radio"/>	<input type="radio"/>
<input type="text"/>	<input type="radio"/>	<input type="radio"/>	<input type="radio"/>	<input type="radio"/>	<input type="radio"/>

Display This Question:

If Choose three products you consider the most iconic. = Stratocaster Guitar

What makes this product immediately identifiable?



	Least important	Slightly important	Neutral	Very important	Most important
Form (details)	<input type="radio"/>	<input type="radio"/>	<input type="radio"/>	<input type="radio"/>	<input type="radio"/>
Materials	<input type="radio"/>	<input type="radio"/>	<input type="radio"/>	<input type="radio"/>	<input type="radio"/>
Colors	<input type="radio"/>	<input type="radio"/>	<input type="radio"/>	<input type="radio"/>	<input type="radio"/>
Overall Appearance	<input type="radio"/>	<input type="radio"/>	<input type="radio"/>	<input type="radio"/>	<input type="radio"/>
Other <input type="text"/>	<input type="radio"/>	<input type="radio"/>	<input type="radio"/>	<input type="radio"/>	<input type="radio"/>

Display This Question:

If Choose three products you consider the most iconic. = Victorinox Knives

What makes this product immediately identifiable?



	Least important	Slightly important	Neutral	Very important	Most important
Form (details)	<input type="radio"/>	<input type="radio"/>	<input type="radio"/>	<input type="radio"/>	<input type="radio"/>
Materials	<input type="radio"/>	<input type="radio"/>	<input type="radio"/>	<input type="radio"/>	<input type="radio"/>
Colors	<input type="radio"/>	<input type="radio"/>	<input type="radio"/>	<input type="radio"/>	<input type="radio"/>
Overall Appearance	<input type="radio"/>	<input type="radio"/>	<input type="radio"/>	<input type="radio"/>	<input type="radio"/>
Other <input type="text"/>	<input type="radio"/>	<input type="radio"/>	<input type="radio"/>	<input type="radio"/>	<input type="radio"/>

Display This Question:

If Choose three products you consider the most iconic. = Anglepoise Lamp

What makes this product immediately identifiable?



	Least important	Slightly important	Neutral	Very important	Most important
Form (details)	<input type="radio"/>	<input type="radio"/>	<input type="radio"/>	<input type="radio"/>	<input type="radio"/>
Materials	<input type="radio"/>	<input type="radio"/>	<input type="radio"/>	<input type="radio"/>	<input type="radio"/>
Colors	<input type="radio"/>	<input type="radio"/>	<input type="radio"/>	<input type="radio"/>	<input type="radio"/>
Overall Appearance	<input type="radio"/>	<input type="radio"/>	<input type="radio"/>	<input type="radio"/>	<input type="radio"/>
Other <input type="text"/>	<input type="radio"/>	<input type="radio"/>	<input type="radio"/>	<input type="radio"/>	<input type="radio"/>

Display This Question:

If Choose three products you consider the most iconic. = KitchenAid Stand mixer

What makes this product immediately identifiable?



	Least important	Slightly important	Neutral	Very important	Most important
Form (details)	<input type="radio"/>	<input type="radio"/>	<input type="radio"/>	<input type="radio"/>	<input type="radio"/>
Materials	<input type="radio"/>	<input type="radio"/>	<input type="radio"/>	<input type="radio"/>	<input type="radio"/>
Colors	<input type="radio"/>	<input type="radio"/>	<input type="radio"/>	<input type="radio"/>	<input type="radio"/>
Overall Appearance	<input type="radio"/>	<input type="radio"/>	<input type="radio"/>	<input type="radio"/>	<input type="radio"/>
Other	<input type="radio"/>	<input type="radio"/>	<input type="radio"/>	<input type="radio"/>	<input type="radio"/>
<input type="text"/>	<input type="radio"/>	<input type="radio"/>	<input type="radio"/>	<input type="radio"/>	<input type="radio"/>

Display This Question:

If Choose three products you consider the most iconic. = Lego

What makes this product immediately identifiable?



	Least important	Slightly important	Neutral	Very important	Most important
Form (details)	<input type="radio"/>	<input type="radio"/>	<input type="radio"/>	<input type="radio"/>	<input type="radio"/>
Materials	<input type="radio"/>	<input type="radio"/>	<input type="radio"/>	<input type="radio"/>	<input type="radio"/>
Colors	<input type="radio"/>	<input type="radio"/>	<input type="radio"/>	<input type="radio"/>	<input type="radio"/>
Overall Appearance	<input type="radio"/>	<input type="radio"/>	<input type="radio"/>	<input type="radio"/>	<input type="radio"/>
Other <input type="text"/>	<input type="radio"/>	<input type="radio"/>	<input type="radio"/>	<input type="radio"/>	<input type="radio"/>

Display This Question:

If Choose three products you consider the most iconic. = Fiskars Scissors

What makes this product immediately identifiable?



	Least important	Slightly important	Neutral	Very important	Most important
Form (details)	<input type="radio"/>	<input type="radio"/>	<input type="radio"/>	<input type="radio"/>	<input type="radio"/>
Materials	<input type="radio"/>	<input type="radio"/>	<input type="radio"/>	<input type="radio"/>	<input type="radio"/>
Colors	<input type="radio"/>	<input type="radio"/>	<input type="radio"/>	<input type="radio"/>	<input type="radio"/>
Overall Appearance	<input type="radio"/>	<input type="radio"/>	<input type="radio"/>	<input type="radio"/>	<input type="radio"/>
Other <input type="text"/>	<input type="radio"/>	<input type="radio"/>	<input type="radio"/>	<input type="radio"/>	<input type="radio"/>



Display This Question:

If Choose three products you consider the most iconic. = Scotch Tape

What makes this product immediately identifiable?



	Least important	Slightly important	Neutral	Very important	Most important
Form (details)	<input type="radio"/>	<input type="radio"/>	<input type="radio"/>	<input type="radio"/>	<input type="radio"/>
Materials	<input type="radio"/>	<input type="radio"/>	<input type="radio"/>	<input type="radio"/>	<input type="radio"/>
Colors	<input type="radio"/>	<input type="radio"/>	<input type="radio"/>	<input type="radio"/>	<input type="radio"/>
Overall Appearance	<input type="radio"/>	<input type="radio"/>	<input type="radio"/>	<input type="radio"/>	<input type="radio"/>
Other <input type="text"/>	<input type="radio"/>	<input type="radio"/>	<input type="radio"/>	<input type="radio"/>	<input type="radio"/>

Display This Question:

If Choose three products you consider the most iconic. = Weber Grill

What makes this product immediately identifiable?



	Least important	Slightly important	Neutral	Very important	Most important
Form (details)	<input type="radio"/>	<input type="radio"/>	<input type="radio"/>	<input type="radio"/>	<input type="radio"/>
Materials	<input type="radio"/>	<input type="radio"/>	<input type="radio"/>	<input type="radio"/>	<input type="radio"/>
Colors	<input type="radio"/>	<input type="radio"/>	<input type="radio"/>	<input type="radio"/>	<input type="radio"/>
Overall Appearance	<input type="radio"/>	<input type="radio"/>	<input type="radio"/>	<input type="radio"/>	<input type="radio"/>
Other <input type="text"/>	<input type="radio"/>	<input type="radio"/>	<input type="radio"/>	<input type="radio"/>	<input type="radio"/>

-----  
Comment

---

---

---

---

---

## Appendix B

### Information Letter of the Online Survey for this Study



COLLEGE OF ARCHITECTURE,  
DESIGN & CONSTRUCTION

DEPARTMENT OF INDUSTRIAL AND GRAPHIC DESIGN

(NOTE: DO NOT AGREE TO PARTICIPATE UNLESS AN IRB APPROVAL STAMP WITH CURRENT DATES HAS BEEN APPLIED TO THIS DOCUMENT.)

**INFORMATION LETTER**  
for a Research Study entitled  
"Product Icon Survey"

You are invited to participate in a research study to investigate *the definition of a product icon and the key elements that make a product iconic*. This study is being conducted by Si Luo, under the direction of associate professor Shea Tillman in the Auburn University School of Industrial and Graphic Design. You are invited to participate because you are currently working as a designer, and are age 19 or older.

If you decide to participate in this research study, you will be asked to take an anonymous online survey through Qualtrics. Your total time commitment will be approximately 5-7 minutes.

Your participation in this study is completely anonymous and voluntary. There are no foreseeable risks associated with this study. However, if you feel uncomfortable answering any questions, you can withdraw from the survey at any time by closing your browser window. Once you've submitted anonymous data, it cannot be withdrawn since it will be unidentifiable. Your decision about whether or not to participate will not jeopardize your future relations with the School of Industrial and Graphic Design and Auburn University.

Information collected through your participation may be used for publication or professional presentation.

If you have any questions about this study, please ask them now or contact Si Luo at [szl0085@auburn.edu](mailto:szl0085@auburn.edu), or Shea Tillman at [tillmts@auburn.edu](mailto:tillmts@auburn.edu).

If you have questions about your rights as a research participant, you may contact the Auburn University Office of Human Subjects Research or the Institutional Review Board by phone (334)-844-5966 or e-mail at [IRBadmin@auburn.edu](mailto:IRBadmin@auburn.edu) or [IRBChair@auburn.edu](mailto:IRBChair@auburn.edu).

207 WALLACE HALL  
AUBURN, AL 36849-5121

TELEPHONE:  
334-844-2364

FAX:  
334-844-2367

[www.auburn.edu](http://www.auburn.edu)

**Add this approval information in sentence form to your electronic information letter!**

The Auburn University Institutional Review Board has approved this Document for use from 02/20/2017 to 02/19/2020  
Protocol # 16-434 EX 1702



COLLEGE OF ARCHITECTURE,  
DESIGN & CONSTRUCTION

DEPARTMENT OF INDUSTRIAL AND GRAPHIC DESIGN

HAVING READ THE INFORMATION PROVIDED, YOU MUST DECIDE IF YOU WANT TO PARTICIPATE IN THIS RESEARCH PROJECT. IF YOU DECIDE TO PARTICIPATE, THE DATA YOU PROVIDE WILL SERVE AS YOUR AGREEMENT TO DO SO. THIS LETTER IS YOURS TO KEEP.

*Si Luo*

11/28/2016

Investigator's signature

Date

Si Luo  
Print Name

*The Auburn University Institutional Review Board has approved this document for use from \_\_\_\_\_ to \_\_\_\_\_. Protocol # \_\_\_\_\_*

[https://auburn.qualtrics.com/SE/?SID=SV\\_7ZKX3ayGrmlgNdb](https://auburn.qualtrics.com/SE/?SID=SV_7ZKX3ayGrmlgNdb)

207 WALLACE HALL  
AUBURN, AL 36849-5121

TELEPHONE:  
334-844-2364

FAX:  
334-844-2367

[www.auburn.edu](http://www.auburn.edu)

**Add this approval information in sentence form to your electronic information letter!**

The Auburn University Institutional Review Board has approved this Document for use from 02/20/2017 to 02/19/2020  
Protocol # 16-434 EX 1702

## Appendix C

### The Invitation Email for the Online Survey

Dear Designers,

My name is Si Luo. I am a graduate student in the School of Industrial and Graphic Design at Auburn University. I would like to invite you to participate in my research study to investigate the key elements that make a product iconic. You are invited because you are currently working as a designer. You need to be 19 or older to be able to participate in this study.

Participants will be asked to take an anonymous online survey through Qualtrics. Your total time commitment will be approximately 5-7 minutes.

Your participation in this study is completely anonymous and voluntary. There are no foreseeable risks associated with this study. The information collected through your participation may help me to better understand the definition of a product icon.

If you decide to participate, you can click the link below:

[https://auburn.qualtrics.com/SE/?SID=SV\\_7ZKX3ayGrmlgNdb](https://auburn.qualtrics.com/SE/?SID=SV_7ZKX3ayGrmlgNdb)

If you decide not to participate your survey, your decision will not jeopardize your relationship with the School of Industrial and Graphic Design, and Auburn University.

If you have any questions, please contact me at [szl0085@auburn.edu](mailto:szl0085@auburn.edu), or Shea Tillman at [tillmts@auburn.edu](mailto:tillmts@auburn.edu).

Thank you for your consideration.

Sincerely,

A handwritten signature in black ink that reads "Si Luo". The letters are cursive and fluid.

## Appendix D

### The Recruitment Messages for the Online Survey



Hello Designers, My name is Si Luo. I am a graduate student in the School of Industrial and Graphic Design at Auburn University. I would like to invite you to participate in my research study to investigate the definition of a product icon and the key elements that make a product iconic. The survey should take 5-7 minutes to complete. Your participation in this study is completely anonymous and voluntary. There are no identifiable or sensitive data will be collected. If you are interested about the survey, please click the link below. I am really appreciated your input!

[https://auburn.qualtrics.com/SE/?SID=SV\\_7ZKX3ayGrm1gNdb](https://auburn.qualtrics.com/SE/?SID=SV_7ZKX3ayGrm1gNdb)

Appendix E

Approved Email from Office of Research Compliance of Auburn University

# Approval, Exempt Protocol #16-434 EX 1702

IRB Administration <irbadmin@auburn.edu>

Mon 2/20/2017 15:04

To: Si Luo <szl0085@tigermail.auburn.edu>;

Cc: Shea Tillman <tillmts@auburn.edu>;

📎 2 attachments (1 MB)

Investigators Responsibilities rev 1-2011.docx; Luo 16-434 EX 1702 New.pdf;

Use [IRBsubmit@auburn.edu](mailto:IRBsubmit@auburn.edu) for protocol-related submissions and [IRBadmin@auburn.edu](mailto:IRBadmin@auburn.edu) for questions and information.  
The IRB only accepts forms posted at <https://cws.auburn.edu/vpr/compliance/humansubjects/?Forms> and submitted electronically.

Dear Si,

Your protocol entitled "What Defines a Product Icon? Survey" has been approved by the IRB as "Exempt" under federal regulation 45 CFR 46.101(b)(2).

**Official notice:**

This e-mail serves as official notice that your protocol has been approved. A formal approval letter will not be sent unless you notify us that you need one. By accepting this approval, you also accept your responsibilities associated with this approval. Details of your responsibilities are attached. Please print and retain.

**Electronic Information Letter:**

A copy of your approved protocol is attached. However you still need to *add the following IRB approval information to your information letter(s):* **"The Auburn University Institutional Review Board has approved this document for use from February 20, 2017 to February 19, 2020. Protocol #16-434 EX 1702"**

You must use the updated document(s) to consent participants. *Please forward the actual electronic letter(s) with a live link so that we may print a final copy for our files.*

**Expiration – Approval for three year period:**

Your protocol will expire on **February 19, 2020**. About three weeks before that time you will need to submit a renewal request.

**When you have completed all research activities,** have no plans to collect additional data and have destroyed all identifiable information as approved by the IRB, please notify this office via e-mail. A final report is no longer required for Exempt protocols.

If you have any questions, please let us know.  
Best wishes for success with your research!

Office of Research Compliance  
115 Ramsay Hall  
Auburn University, AL 36849  
334-844-5966