

**AN INCLUSIVE DESIGN GUIDELINE FOR DESIGNING ELDERLY  
FRIENDLY SMART HOME CONTROL DEVICE**

by

Minxiang Luo

A thesis submitted to the Graduate Faculty of  
Auburn University  
in partial fulfillment of the  
requirements of the Degree of  
Master of Industrial Design

Auburn, Alabama

August 3, 2019

Keywords: Smart home, older users, gerotechnology, age in place, inclusive design

Copyright 2019 by Minxiang Luo

Approved by

Tin-Man Lau, Chair, Professor of Industrial Design  
Shea Tillman, Associate Professor of Industrial Design  
Carlton R Lay, Assistant Professor of Industrial Design

## Abstract

Concerns related to age and aging of older people has been lingering around many people's minds, especially for the older adults who are about to enter their young-old stage of life or already experiencing the physical and psychological changes of their bodies. However, technology has the potential to bring people closer to each other, to assist communication with family, to monitor the health status of the elderly, and to make life a little easier. In this case, an expected rise of numbers of family needing help and support for their older family members would continuously increase the desire of products that are inclusively designed for an aging population. Both the aging process and smart home technology are studied from the literature review. A design guideline that synthesizes the principles of human-centered design and inclusive design for older users with the innovation and possibility of elderly-friendly smart home control devices is created, coupled with a universal remote control to demonstrate the use of this guideline.

## Acknowledgements

I want to thank my committees, Tin-Man Lau, Shea Tillman, and Carlton R Lay, for all their help and guidance throughout the process of conducting and writing the thesis. Special thanks go to Tin-Man for setting up the weekly meetings, so that all his graduate students have the chance to share their dissertations. Thanks to Beth Topping for reviewing my thesis on a very tight timetable. Thanks to Zeyuan Li for 3D printing my model. Thanks to Shane An for all the room reservation and discussion we had in the library. Thanks to Ying Yan for the encouragement.

Last but most importantly, I would like to thank my family, especially my Mom and my Dad, who financially and emotionally supported me for this graduate study.

## Table of Contents

Abstract.....	ii
Acknowledgments .....	iii
List of Tables .....	v
List of Illustrations.....	vi
List of Abbreviations .....	vii
Chapter 1 Introduction .....	1
1.1 Problem Statement .....	1
1.2 Need for Stud .....	2
1.3 Objectives in Study .....	5
1.4 Assumptions .....	6
1.5 Scope & Limitations .....	6
1.6 Anticipated Outcome .....	6
Chapter 2 Literature Review.....	11
2.1 Background .....	8
2.2 Aging and Technology .....	25
2.3 Design Methodologies .....	35
2.4 Smart Home .....	59
Chapter 3 Design Guideline.....	21

3.1 Principles .....	62
3.2 Environment.....	65
3.3 Components .....	86
Chapter 4 Design Application.....	113
4.1 Project introduction .....	113
4.2 Environment analysis.....	114
4.3 Components identification .....	123
4.4 Conclusion .....	137
References .....	138

## List of Tables

Table 1 .....	28
Table 2 .....	29
Table 3 .....	54
Table 4 .....	68
Table 5 .....	69
Table 6 .....	71
Table 7 .....	71
Table 8 .....	85
Table 9 .....	87

## List of Illustrations

Figure 1 .....	31
Figure 2 .....	32
Figure 3 .....	51
Figure 4 .....	57
Figure 5 .....	75
Figure 6 .....	76
Figure 7 .....	78
Figure 8 .....	79
Figure 9 .....	81
Figure 10 .....	83
Figure 11 .....	88
Figure 12 .....	89
Figure 13 .....	90
Figure 14 .....	91
Figure 15 .....	107
Figure 16 .....	108
Figure 17 .....	108
Figure 18 .....	125
Figure 19 .....	126
Figure 20 .....	127

Figure 21 .....	127
Figure 22 .....	130
Figure 23 .....	131
Figure 24 .....	132
Figure 25 .....	133
Figure 26 .....	134
Figure 27 .....	135
Figure 28 .....	135
Figure 29 .....	136
Figure 30 .....	136



## List of Abbreviations

AARP American Association of Retired Persons

ACD Activity-Centered Design

AR Augmented Reality

AT Assistive Technology

HCD Human-Centered Design

IS Information Systems

PDA Personal Digital Assistants

TMA Technology Acceptance Model

UFOV Useful Field of View

UI/UX User Interface/User Experience

VR Virtual Reality

## CHAPTER 1

### INTRODUCTION

#### 1.1 Problem Statement

Over the last two decades, concerns related to age and aging of elderly people has been lingering around many people's minds, especially for the older adults who are about to enter their young-old stage of life or already experiencing the physical and psychological changes of their bodies. At the same time, there has been a dilemma about what should society do and what should individuals do in our modern society, and the emphasis of the public opinions vary in different time periods and societies. Taking the American society as an example, the society is providing much more opportunities to allow older people keep an active social status in their post-retirement life than before, which, at the same time, shifts the attention of society members from support of government and organizations to the responsibilities of individuals.

From a demographic stand point, as the baby boomer generation, the largest age segment of US population, progressively reaches retirement age, many things will change just like schools and workplaces have changed. In addition, life expectancy of people all around the world has increased dramatically due to advancement of modern medicine and stabilization of society. As a result, it is not difficult to see a retired life of 30 years which is almost 3/4 of one's career life for modern elderly people. Much research and many practices have been dedicated to exploring what, where and how should elderly people

spend the rest of their life. In the western culture, having elderly parents stay in-home with family was never a preferable practice even until now. It is not to say nobody cares for older family members, but the belief of “intimacy with distance” in western history led to the concept of providing care for family members without necessity of staying in the same house. Most adults’ children would choose to live separately from their parents, while, on the other hand, parents sometimes move close to their children upon changes in their specific life situations rather than choosing retirement institutions or nursing homes. However, technology has the potential to bring people closer to each other, to assist communication with family, to monitor health status of elderly, and to make life a little easier. In this case, an expected rise of numbers of family needing help and support for their older family members would continuously increase the desire of products that are inclusively designed for an aging population.

## **1.2 Need for study**

It is not hard to guess the answer of the survey question investigating places at which elderly people would prefer to spend their later life is home, and, according to widely cited research by the AARP, “almost 90% of those 65 and older want to stay in their current homes for as long as possible” (Farber, Shinkle, Lynott, Fox-Grage, & Harrell, 2011). However, in the reality, this is a much more complex question to answer rather than making a great headline for newspapers or magazines. Obviously, not every elder person can live at home because some of them who are infirm, that is, have low or even no mobility, cannot bathe themselves safely, or have trouble feeding themselves. A lot of

difficult circumstances will force them to live in an assisted environment, such as a nursing home, retirement community, or having personal care at home. In addition, the survey did not address the ambiguity of the meaning of the word “home” in the surveys, which leaves the aspects of home that attracts elder people uncertain, even though the survey did reveal that 69% of those people who choose to live at home because they like what their community has to offer and 27% because they cannot afford to move. Besides all that, there is still a large portion of elderly population who are willing to and will spend most of their latter life living at home. Actually, much research has already shown that only a small percent of elderly live in nursing homes, and most others live in ordinary houses. Therefore, home meaning comfort zone, privacy, self-sufficient, and being a pleasant, safe, and competent living place for elderly people becomes significantly crucial.

Home environment is connected to the sense of self, especially for elderly people, through a variety of ways (Swenson, 1998). People feel attached to their homes as if it is part of their bodies, and, moreover, they often consider home as a starting point to communicate with the larger community outside. For older adults, including but not limited to those who are active in social activities, they not only have desires to keep their independency and autonomy, but also try to remain needed and useful to the world just like other age groups do. Research has revealed that understanding and reinforcing the meaning of home attached to the behavior, physical, cognitive health, and mental well-being of elder dwellers could help them to stay in their home as long as possible and assist in planning and preparing the transition to nursing home or other institutions when that situation becomes necessary. One characteristic of home that has been pointed out in

research is that the symbolism and meaning of home would stay intact even when the physical building or the environment around it changed, because the significance of the concept of home is mediated through the experience of one's everyday living in the place (Swenson, 1998). In other words, it gives human centered design the opportunity to enhance the good experience of living at home, improve life quality through design, and assist the physical, mental, cognitive, and social well-being of the aging population.

Another perspective to look at with the living situation of elderly population is that every individual in our modern society will have to interact with some kind of technology, no matter if it is a display, an interface, or an input or output device. Technologies are integrated in every aspect of daily life. There were over 230 million smartphone users in the US alone for the year 2018, and data shows the number is still increasing ("Number of smartphone users worldwide 2014-2020," 2016). There have been myths about older adults, that "older adults prefers the old fashion ways of doing things" or "you cannot teach an old dog new trick, and that's what people often unconsciously assume towards the relationship between technology and elderly people. However, much research has proved that the myth is not true. About 32% of older adults who are 65 or over own at least one tablets, 40% of people who are aged 65 or older are smartphone owners, 51% of seniors who are 65 and over used homeboard, and 65% of people who are 65 years old and plus use the internet (Anderson & Perrin, 2017). This doesn't include the technologies that have been deeply embedded into their daily life, such as the microwave, TV, washing machine, video recorder, and answering machine. Technology has progressively permeated, mediated, and even controlled everywhere in our world to the most intimate

relations of ours, and moreover, there still are a lot of applications of technology and devices that are very hard for people to use. Either they do not function properly, or its complexity seems to be beyond one's capability. We all know that technology has a huge potential to help elderly people in remaining safe and self-sufficient in their home, in assisting their health care, in providing easy communication with family and friends, and in participating in social activities. For all these reasons, as an industrial designer, I see the necessity and need of refining current products and developing an inclusive and human-centered design guideline for future products.

### **1.3 Objectives in Study**

As the demographic of users identified in human center design process is the elderly population, the first objective of this thesis is to investigate the aging process of elderly people in physical, cognitive and mental aspects through a literature review of academic journals and research papers. A broader study in gerontology, the study of aging in variety of fields including biology, nursing, medicine, criminology, dentistry, social work, physical and occupational therapy, psychology, psychiatry, sociology, economics, political science, architecture, geography, pharmacy, public health, housing, and anthropology, will be included to find references on how the same problem is being solved in other academic fields. Inclusive design and universal design methodologies will be studied and used as a fundamental structure on which the application of research findings would be built. Because the smart home appliances will be the main focus of this guideline, characteristics, features, functions, and case studies of all types of household appliances will be analyzed

with study of gerotechnology in which the relationship between elderly user and technology will be considered. Finally, the guideline will be tested and presented through a smart home appliances design example that shows how smart products can be designed to improve the life quality of elderly people.

#### **1.4 Assumption**

For the establishment of this design guideline focused on smart home appliances for elderly users, there are multiple assumptions in this study:

- Definitions and results of surveys and experiments in gerontology generated by gerontologists will be assumed to be correct.
- For the inclusive/universal design methodologies, the general definitions and practices used and analyzed by professionals are assumed to be valid.

#### **1.5 Scope & Limitation**

All academic literature material is selectively reviewed depending on the degree to which potential effectiveness of design practices that are implemented on the smart home control product/system could achieve, due to the fact that many issues related to this topic require interdisciplinary solutions.

#### **1.6 Anticipated outcome**

This thesis will create a design guideline that synthesizes the principles of human-centered design and inclusive design for elderly people with the innovation and possibility

of elderly friendly smart home control devices.



## **CHAPTER 2**

### **LITERATURE REVIEW**

#### **2.1.1 Background**

##### **Demographic Status**

Starting from late 18<sup>th</sup> century, the size and structure of global population is undergoing a tremendous change. The number of world population has increased by an order of magnitude to over 6 billion and is predicted to reach 9 billion by 2050. In addition, the distribution of population has been observed, and will increasingly become, uneven across the world (Bloom & Canning, 2004). Research data shows a demographic shift, that is, first mortality of infant and children declined due to environmental interventions related to clean water and sanitation which improved public health, and medical interventions such as vaccine coverage and use of antibiotics (Bloom & Canning, 2004), then fertility declined. The causes of the fertility decline are associated with variety of social and economic factors, such as falling infant mortality rates, high levels of female education and labor market opportunities that reduce desired fertility, and provision of family planning services (Schultz & economics, 1997).

Many economic theories of fertility originated from idea of wishing to have a certain number of surviving children, rather than births per se to maintain the family size (Bloom & Canning). If this assumption is sound, it could therefore explain that when parents realize a prominent increase in children survival, the fertility will decline. However, the

relationship between survival and fertility is more complicated in reality, because some of the improvement in child survival is itself a response to the decision made by parents to invest more in the health and welfare of a smaller number of children (Nerlove, 1974). In other words, the economic change could influence the cost and benefits of childbearing, which is reflected in the decline of fertility. From a social perspective, our highly developed market systems and governments has provided a lot for benefits, like risk sharing and provision of retirement income, which replaced many important economic functions of traditional family, therefore further weakening the value of children (Lee, 2003) By contrast, the life expectancy gains observed over the past few decades (especially in high-income countries) and projected into the future are predominantly associated with improvements in modern medical technology, coupled with change of life-style and income growth, by which age-specific death rates at the middle and older ages reduced. These factors cause population growth rates to accelerate at first and then to slow again, moving toward low fertility, long life and an older population. This transition has now spread to all parts of the world and will complete by 2100 (Lee, 2003).

When we look at the proportion of the total population in 1700, the percentage of total population under 15 is 36% and that of those over 65 is 4%; in 2000 it reduced to 30% of population under 15 and 7% of population over 65 (Lee, 2003). In the next 30 years, the number of older populations in the US is expected to increase tremendously because the baby boom generation is progressively reaching 65. The population will double from a present 35 million to 70 million, and it will continue to raise significantly to a projected 82 million older people by 2050. Moreover, the percentage of older

population will jump from 12.4% (2001) to projected 20% by 2030 (Tepper & Cassidy, 2004).

### **Living arrangements**

Many older adults may be institutionalized due to severe health problems, physical/mental disability, or other circumstances, and much research on living environments of the elder population is focused on nursing facilities, and other institutional facilities. However, the percentage of elderly who live in these places is actually very small, and there is still a large proportion of older population are living in their own homes. Majority (about 95%) of persons who are 65 and older are living in their community, rather than in an institution. 22 million out of the 35 million older people in the US lived in family homes, 10 million lived alone, and only 1.56 million, which is about 5% of the older population, lived in institutions in 2001 (Census., 2002a). However, U.S. Census Bureau has recorded that the proportion of older adults in each type of living arrangement, including living in group quarters, living alone, living with family, and living with nonfamily in a household, changed with increasing age. The likelihood of living in a family household diminished with age from 73 percent among people aged 65 to 74 to 48 percent for those 85 and older; conversely, people living alone almost doubled from 22 percent for the former age group to 39 percent for the latter. In addition, the percentage of older adults living in group quarters, such as nursing home, health care facilities, residential schools for people with disabilities, etc., also increased dramatically with age, ranging from 1.4% for 65-74 years old to 3.2% for 75-84 years old, and 10.6%

for 85 years old and older (Andrew W. Roberts, 2018) The fact that the majority of elderly population are living in normal household sets the design context of this thesis on common home settings of older adults.

### **Education**

High education plays an important role in well-being at older ages, because higher levels of education usually are associated with higher incomes, higher standards of living, and above-average health status among older adults. In fact, the current generation of older Americans had much better education than previous generations. For example, in 1965, the percentage of the older population who had graduated from high school is only 24%, and this number rose to 84% in 2015. Furthermore, the percentage of older adults who had at least a bachelor's degree rose from 5% in 1965 to 27% in 2015, and this trend will continue as can be seen from the data(Statistics, 2016). In the future, most elderly people are graduated from high school, and over a quarter have college degrees. This increase of educational attainment creates great socioeconomic impact and expands opportunities for future elderly people. Along with the rapid advancement of technology, the market needs of future older population might be completely different from now.

### **Economics**

Not only is the education level of the current cohort of older adults better, but their financial status is also better than previous generations of elderly. In 2012, people aged 65 and older had an average income of \$31,742, the number of low-income elderly

percentage decreased from 27.5% (in 2000) to 24.6%, and the number of high-income elderly percentage increased from 27.1%(in 2000) to 32.6%.(Statistics, 2016). The poverty rate of this group has also declined over the past 30 years.

Net worth of elderly is also an important indicator of their well-being and their ability of managing stressful life events, such as retirement, health problem, or divorce/widowhood. In the past 30 years, the median net worth among households headed by older adults who are 65 and older increased from \$116,480(1983) to \$ 210,500(2013), which is an increase of over 80%. At the same time, educational attainment has been found to be the most significant indicator that affects net worth. This vast growth of older population which is the wealthiest older generation with highest education level in the history will bring both great challenges and expanded market opportunities to our society.

## **Conclusion**

The continuous expansion of older population across the world brings with it an array of challenges that both younger and older generations in contemporary will have to face one way or another. However, expanded opportunities will also emerge along with changes in demographic structure, living environment, educational level, and economical status of the older population. As the “Baby Boomer” generation, those who are born between 1946 and 1964, progressively enter their old age, the percentage of older population will increase dramatically, and, as a result, the difficulty of providing elderly better quality of life in the context of home environment, due to majority of older adults

in U.S. society preferring to live in their own homes for as long as possible, will also increase greatly, raising the demands for adequate strategies and solutions for elderly friendly products and services. In addition, this cohort of older adults, which is the wealthiest older generation with highest education level compared to previous older generations in the history, indicating their higher standards of living, above-average health status, and more diverse needs, requires even more effort to be devoted into related researches and practices.

### **2.1.2 Aging Process**

#### **introduction**

An explicit understanding of the physical and cognitive changes in the aging process of older adults is crucial for exploring age-related problems that older users encounter in performing daily activities, identifying pain points from the interactions between users and products or services, and accurately empathizing with targeted users in order to develop appropriate design solutions and optimize their product experiences. In this chapter, age-related differences will be discussed in separate sections categorized as physical changes and cognitive changes under which different aspects of each category of aging processes are analyzed systematically through literature review.

#### **Physical Changes**

##### ***changes in height.***

People all lose height as they age, but the variability in both the age of onset and the rate of loss is tremendous. The average change of height of older people who reach age 80 is about two inches. Some of the losses happen in the torso because of changes in posture, growth of vertebrae, a forward bending of the spine, and compression of the disks between the vertebrae, while some changes in the legs and feet also contribute to this loss, such as curvature of the hips and knees, decreased joint space in the extremities, and flattening of the arches in the feet. (Williams, 2016)

#### ***changes in muscles and bones.***

Most older people lose a substantial amount of muscle as they age, and the muscles decrease in strength, endurance, size, and weight relatively to the overall body weight. However, it has been suggested that the decrease of muscles may be due not to aging, but rather to inactivity, nutritional deficiency, disease, or other long-standing conditions. The diaphragm and the heart, which are the two muscles that work constantly throughout life, appear to be relatively unchanged by aging. Also, decreased water content in cartilage, the flexible, cushioning substance that provides the lubricating surface of most joints, and changes of its structure and chemistry, will reduce the ability for it to bounce back during repetitive stress as people grow old. Furthermore, bone loss is a universal aspect of aging. The bones become thinner, more porous, and significantly weaker, which is due to losing horizontal support in the internal latticework of bones (Williams, 2016)

#### ***changes in the senses.***

## *vision*

Vision decline is a common problem in the aging process among older adults. Many older people report having difficulties in performing a variety of everyday visual activities caused by deficits in basic functions of speed of visual processing, light sensitivity, near vision, visual search and dynamic vision. Brief explanations of each problem will be presented in this section.

As people get older, changes in pupil size will reduce the amount of light that reaches the retina, which is especially a problem in a low light level environment, which explains the decline of light sensitivity in old age (Winn, Whitaker, Elliott, & Phillips, 1994). Another cause of reducing perceived light, as an addition to the first one, is that older lenses become opaquer and somewhat yellowed, and this change filters out some of the short-wavelength color like blue in the light (Kashima, Trus, Unser, Edwards, & Datiles, 1993). Loss of near focusing ability, known as presbyopia, also occurs with age due to a reduced elasticity of the lens and weakening of the ciliary muscle, which manipulates the lens shape to control focus. This age-related vision change causes blurry vision for nearby objects or images and requires many older adults to use multifocal glasses to see things well (Burdick & Kwon, 2004). Light scattering within the older eye also adds to images blurring and decreases image contrast (Van Den Berg, 1995).

Elder people also lose their ability to quickly adapt to abrupt changes in light as they age. It means that when older people abruptly shift from a dark environment to light, such as walking out of/into a dark house to/from a sunny driveway, they can be temporarily blind while the eyes adapt (Williams, 2016).



### *hearing*

Many older adults experience significant changes in the structure and shape of the ear and problems involving hearing, such as slowing of auditory processing, hearing in noisy environments, understanding both normal and distorted speech, and hearing sounds of higher frequency (Slawinski, Hartel, & Kline, 1993 1993). These problems are results of a series of changes within the auditory system through the aging process. The walls of the ear canal become thinner, the eardrum thickens, which loses the elasticity resulting in a reduction in signal strength, and the small bones of the middle ear also calcify, diminishing signal amplitude further (Etholm & Belal Jr, 1974; Williams, 2016)

Presbycusis, the loss of ability to hear simple tones, becomes more common with age in both older men and women, though the loss is slightly milder for women, and it is more pronounced at higher frequencies than lower frequencies (Etholm & Belal Jr, 1974 2016). The decrease of ability to distinguish between different pitches is also commonly associated with aging. For people between 25 and 55 years old, the pitch discrimination declines linearly, but for those who are 55 and older, the declines are steeper, especially for very high and low frequencies. This is very important because pitch discrimination plays a significant role in speech perception, even without pure tone hearing loss. This decline is felt even more acutely in situations with ambient noise (Williams, 2016).

### *touch*

Generally speaking, the sensitivity of various parts of the human body, such as the

fingers, feet, lips, nose, and the fleshy area below the thumb decreases at different rate for different types of touch. These include sensitivity to pressure, vibration, spatial acuity, and the perception of roughness, length, and orientation (Etholm & Belal Jr, 1974 2016). As results of these changes, movement time, defined as the interval between the initiation and ending of movement, increases for a variety of point-to-point movement and continuous movements, especially big movements. Forces used to move are more unstable, peak velocity is lower, the deceleration phase, where corrective action can be taken, is disproportionately lengthened, and the number of secondary/corrective movements to a target is increased (Etholm & Belal Jr, 1974).

### *cognitive changes*

Understanding the cognitive changes that occur among older adults is as important as understanding their physical changes to achieve human-centered design for this population. Nonetheless, reviewing all areas of cognitive aging research is beyond the scope and limit of this thesis, so the material that will be covered in this chapter only includes sensory, memory, spatial ability, attention, and text comprehension.

### *sensory*

Research has found that the speed of information processing in the brain and the body changes with age, and most of these changes occur in the central nervous system, where sensory input is translated into responses. In addition, the conduction velocity of sensory and motor nerves located throughout the body also slows with age. This causes older

adults to tend to be slower than younger adults in processing sensory information and reacting to stimuli. However, most older adults tend to value accuracy, which means, as they grow old, they respond to sensory input more slowly but often more accurately (Williams, 2016).

### *memory*

There are several types of memory that are associated with different task domains, and aging affects these aspects of memory in variety of ways. Broadly speaking, searching and retrieving information from memory gets worse over time, encoding processes takes more time and effort as age, partly because of the slowing of sensory processing, but recognition and matching of storage information with cues in context stay intact (Burdick & Kwon, 2004; Williams, 2016).

### *shor-tern memory*

Short-tern memory, also known as working memory, is the term for memories that last about a minute. Tasks related to this function require temporary storage and manipulation of information in memory, such as remembering a telephone number before dialing, or mental calculation during a visit to the grocery store. Working memory has been found to decline with age, and there is some evidence suggesting that working memory decrements increase with task complexity. Several theorists have argued that capacity limitations, speed of processing limitations, and an inability to inhibit unwanted information may underlie theses age-related declines in working memory (Burdick & Kwon, 2004).

### *long-term memory*

Long-term memory, as its literal meaning, handles memories people hold for a longer period, from days to decades, and there are two types of long-term memory. One is known as instinctive or procedural memory. It allows people to perform various skills, tasks, or procedures without conscious action, such as driving, playing music instrument, or typing a thesis. This type of memory does not change even when other types of memory are declining (Williams, 2016).

The other type of long-term memory is known as conscious or declarative memory. Declarative memory involves recall, search and retrieval of factual information that requires our awareness and thought, and one type of declarative memory is semantic memory, which refers to the store of factual information that accrues through a lifetime of learning (Burdick & Kwon, 2004; Williams, 2016). Examples like remembering the meaning of a word, knowing the location of your parent's home, recognizing symbols are all using semantic memory because this knowledge is all acquired from past experiences, not necessarily linked to how or where it is learned. Research shows that this capability does not change as people gets old. When there is new information encountered, people use semantic memory to match this stored information with the pre-existing knowledge base (Burdick & Kwon, 2004; Williams, 2016).

Another type of declarative memory is episodic memory, which draws upon specific episodes or events from life experience, such as what happened on the same day last year, and episodic memory may decline with aging (Williams, 2016).

*retrospective memory and prospective memory.*

Retrospective memory refers to memory for the past, and both working memory and semantic memory belong to this category. In contrast, prospective memory refers to remembering to do things in the future, for example, remembering to return the books to the library on the way home from school. Event-based and time-based prospective memory tasks vary by the demands of the characteristics of the task (Einstein, McDaniel, & Cognition, 1990 1990).

Event-based prospective memory is commonly associated with external cues in the environment that remind people to perform certain tasks, such as placing the shipping box by the door as a reminder to mail the package. In this case, the likelihood of remembering the prospective task is increased by the assistance of cues in the context. On the other hand, time-based prospective memory is lacking this advantage because there are not many external cues. Most time-based prospective tasks are initiated by oneself and require one to perform a task at a certain time or in a specific amount of time, such as calling someone at 4:30 p.m. For this reason, time-based prospective memory changes greater than event-based prospective memory as a person is aging. (Burdick & Kwon, 2004).

*spatial ability*

Spatial ability refers to the ability to imagine and manipulate images, patterns, or a three-dimensional object in one's mind (Shepard & Metzler, 1971). Mentally determining the best approach to manipulate a sofa so that it may pass through a doorframe is an example of use of spatial ability. Empirical evidences have been found quite convincing

in indicating normative age differences in spatial ability, but only limited success has been achieved in identifying the causes of these negative relations between age and spatial abilities (Salthouse, 1992). The effect on use of technology that is associated with spatial ability will be discussed in latter section in this chapter.

### ***attention***

*Everyone knows what attention is, it is the taking possession by the mind, in clear and vivid form, of one out of what seem several simultaneously possible objects or trains of thought. Focalization, concentration, of consciousness are of its essence. It implies withdrawal from some things in order to deal effectively with others (James, 1890).*

This definition of attention provided by William James clearly and effectively explains what attention is. This definition is important because it helps understanding the unlikelihood of the existence of general attentional resource and its multidimensional construct that encompasses a broad array of processes (Craik, 1992).

Selective attention refers to cognitive mechanism that filters out irrelevant information to allow relevant information to be processed in memory (W. A. Rogers, Meyer, Walker, & Fisk, 1998 & Fisk, 1998). An example of the application of selective attention can be sketching in a noisy studio. Older adult's selective attention can be affected by the decline of working memory capacities that are unable to inhibit irrelevant information; this phenomenon may also lead to an increased likelihood of attentional distraction in older adults (McDowd & Shaw, 2000). However, if an older adult has previous experience interacting with the target and distractor information, the age-related

differences in selective attention will be smaller (Clancy & Hoyer, 1994).

### ***reading comprehension***

When people read, they must be able to hold information in memory while computing the relations between successive words and sentences to construct a coherent, integrated representation of the text. For this mental process, the information contained in the text is both processed and maintained in working memory which appears to diminish in capacity as people gets old. Nonetheless, according to the situation model approach to comprehension (Van Dijk, Kintsch, & Van Dijk, 1983 1983), readers create a mental model for the meaning of text by interpreting it in terms of their prior knowledge and drawing inferences, and this process is associated with semantic memory, which is preserved in older adults (Burdick & Kwon, 2004). Generally speaking, decline of the reading comprehension ability has been found in people's old age, but the related levels of performance vary based on different aspects, such as readers (verbal abilities, prior knowledge, and level of education), tasks (e.g., presentation mode), and text variables (e.g., organizational level of the text, type of content). For example, a clear decline in comprehension of narrative text is evident only in the old-old age, and the young-old seem to show a preservation of reading comprehension skills except in cognitively demanding text (De Beni, Borella, Carretti, & Cognition, 2007 & Cognition, 2007).

### **2.1.3 Aging in Place**

#### ***introduction***

Attachment to home has been found to be an important component of emotional and

physical health, especially for elderly people (Rowles, 1978). It includes sensory experiences, memories, cognitive representations, affective concerns, and activities carried out at home (Swenson, 1998). Since studies have proven that the majority of elder population live in their homes, understanding how this attachment affects cognition, autonomy, self-care, and physical and emotional health in aging is crucial for designing elderly friendly products to fit into this context and maintaining an independent later life at homes.

***meaning of home.***

A series of interviews have been conducted by Swenson (Swenson), investigating the meaning of home to older women (age between 75-84) who were living in their own homes, homes in which they were independent. Goals of this study included explaining and understanding the physical, emotional, and practical aspects of the meaning of home; and suggesting constitutive patterns and theoretical constructs that contribute to the development of a conceptual model explaining the meaning of home(Swenson, 1998) The three major constitutive patterns developed from the interviews are: first, home is the center of self, referring to that those women from the interviews characterized themselves and their homes in how they felt attached to the homes as if the houses were part of their bodies (Swenson, 1998). This notion contributes to the explanation about why many older people want to live at their homes for as long as possible. Second, home is the center of caring, representing the nurturing aspect of home, by not only caring themselves, but also for their families and the physical environment within the houses. Demographic data of



2011-2015 revealed that over two million older households are actually caregivers, taking care of over nine million other people who live in their houses (Johnson Jr & Appold, 2017). Third, home is the center of reach, meaning “reaching out” from physical and emotional secure base from which to carry out variety of social activities in the outside world, and a restful and comfortable place to come back to. This study also highlighted an interesting finding in exploring the meaning and symbolism of the home environment, that even when the physical building and area around it change, the meaning of the home remains because it is mediated through all the social experiences within the home (Swenson, 1998).

### ***conclusion***

The research provides a valuable framework that can assist professionals in understanding the multiple meanings of home for older adults, from which design practices aiming to enhance their cognition, autonomy, self-care, and emotional health can be improved. In addition, knowledge about how to understand and maintain the meaning of home for older people also helps in planning for the transition to residential care when that step becomes necessary. For example, the meaning of home could be preserved by the products or services with which older users feel familiar through everyday interaction, and, therefore, become transferable when they are moving from one place to another. This concept is similar to that of the online cloud storage system, which allows users to access their personal files through any computer or smart device that is connected to the internet.

## **2.2 Aging and technology**

### **2.2.1 basic aspects of gerontechnology**

#### ***introduction***

What is gerotechnology? Gerotechnology (also can be called gerontechnology) is an interdisciplinary field of research and application involving gerontology, which is the scientific study of aging, and technology, which includes the development and distribution of technologically based products, environments, and services (Fozard, 2000). The goal of gerotechnology is to improve lives of older people by utilizing technology applications. Therefore, understanding perceptions and use of gerotechnology is crucial to optimize design that may help extend healthy aging in place, and minimize demand on the health care system (Mahmood, Yamamoto, Lee, & Steggell, 2008 & Steggell, 2008).

#### ***older adults and use of technology***

There have been myths about older adult's attitude and willingness toward use of technology, saying "Older adults prefer to do things the old-fashioned way" and new technologies are for the young". While, it is true that older adults potentially take longer time to adopt new technologies, and they typically need more training to perform tasks using technology, , these myths still overstate the relationship between older adults and new technology.

The fact is that current elder population are deeply connected to different kinds of technologies that have permeated into everyone's daily life for long time. A set of research data provided by Pew Research Center in 2017 revealed that the adoption rate of smartphones in elder population continues to trail those of the overall population, and the share of adults ages 65 and over has risen 24% since 2013 (from 18% to 42%). Almost half of older adults who own cellphones have some type of smartphone (Anderson & Perrin, 2017). Not only smartphone use, but also the internet use among the elderly has increased steadily over the last decade and a half. In 2017, about 67% of older adults who are 65 and over reported that they use internet, while this number was 14% in early 2000. In addition, the percentage of senior subscribers to home broadband services has also risen to 51% by 2017, about one third (32%) of older population own tablets, and a fifth own e-readers. Tablet ownership is especially common among seniors with higher education level and those living in higher-income households. Some 62% of older adults with annual household incomes of \$75,000 or more say they own tablet computers, while 56% of college-degree earners say the same. (Anderson & Perrin, 2017)

These data clearly show that a lot of older adults, especially those with more education, have daily interactions with technology. As can be predicted for the future, it is almost impossible for older adults to avoid interactions with certain technology due to such rapid development of technology applications.

### **2.2.2 barriers in use of technology by older adults.**

*factors that impede use of technology.*

One way to get valuable insights about difficulties that older adults encounter when they interact with technology is to ask them. A focus group study was conducted focusing on groups of older people who are age between 65 and 80 by Rogers, Meyer, Walker and Fisk (W. A. Rogers et al.). They were trying to investigate the frustrations and difficulties older people encounters through their daily activities. Even though this study was not specifically focusing on use of technology, one of their findings is the older adults' frustrations with technologies indicate usability problems (see Table 1).

Technology	Quote from Older Adult
Videocassette Recorder	I cannot do that VCR. I can't program that and I have read those directions over and over.
Entertainment Center	My entertainment center . . . somebody told me I could get a all-around remote for it and, I got the remote and I got mad 'cause I couldn't hook it up, so . . . real disgusted, threw it across the room.
Photocopier	Some of these new copy machines, those massive things . . . some of these things you've got now they throw them out and staple 'em . . . But I ain't got brains enough to learn to use 'em.
Camera	Well, I have a camera that I can't operate. I can get the film in there and I can never get it out. I always have to take it to the photo place and say, "please take this film out."
Fax Machine	I would like to fax a letter. I needed to get a letter in a hurry, and I had access to the machine, but I didn't know how to do it. It made me mad.
In-vehicle Technology	We recently had a rental car . . . that array of buttons in the front of you, you know it just unnerves you . . . it did for me . . . I never learned what all the buttons did in the two weeks we had the car.
Online Library Catalog	Well I'm frustrated in the library . . . When they sit you down in front of a computer and they tell you to look it up here. I have to have somebody tell me where to put my fingers.
Electric Mixer	I bought a new mixer and God knows I haven't learned how to use it yet, it's a shame, a new mixer . . . but it's these, ah, modern things you just don't hardly know how to use them.
Word Processor	Word processor! I had to learn the computer when I was fifty years old. It was rough. I remember telling my boss you can teach old dog new tricks, but it's awfully hard on that old dog.

*Note.* These quotes are from the focus groups conducted by Rogers, Meyer, Walker, and Fisk (1998).

**Table 1**

In this study, 53% of the problems are classified as they can potentially be solved by improvement of design, training, or combination of both.

Another survey done by Hancock, Fisk, and Rogers (Hancock, Fisk, & Rogers, 2001) inquired people about their experiences with common household products (see Table 2). Also, this study did not focus on the use of technology and participants are from all ages but reported usability difficulties have indicated the types of problems that people

from all ages encounter with daily products. This research provides a framework for designers to understand the characteristics of technologies that could affect usability of products.

	Young (18–35)	Middle-Aged (36–54)	Young-Old (55–64)	Old (65–91)
<i>Category of Product</i>				
Healthcare Product	39	41	40	44
Over-the-counter Medication	53	57	58	50
Cleaner	49	50	50	48
Toiletry	36	44	44	43
<i>Category of Usability Problem (for those reporting difficulties)</i>				
Text Comprehension	27	32	30	26
Symbol Comprehension	12	22	25	23
Perceptual Difficulties	26	57	55	51
Memory Difficulties	66	51	46	48
Motor Difficulties	80	80	80	94

*Note.* These data are from the product usage survey conducted by Hancock, Fisk, and Rogers (2001).

Table 2

The conclusion of this study is that individuals across the adult’s lifespan may be equally likely to experience difficulty in handling a product. Therefore, it is important to include users into the process of product development.

***recognition of benefit.***

Even if the system is well designed, and proper training is provided, tThis still cannot

guarantee that elderly people will adopt the new technology because the adoption of new technology is influenced by variety of factors. These factors include the relative advantage of technology in comparison with previous method of accomplishing the task; compatibility, that is the degree to which the innovation is perceived as consistent with user's existing values, experiences, and needs; complexity which is negatively related to the rate of adoption (E. M. Rogers, 2010). In addition, accessibility and usability also contribute to the rate of technology adoption, as well as other issues like economic issues, privacy, social and technological environments, etc.

Among all these factors that influence the adoption of new technology, which one of them has the biggest influence? Surveys conducted by Melenhorst (Melenhorst), Rogers, and Bouwhuis (2001) has revealed that when older adults are asked why they choose particular method, the decisions they made are primarily based on the basis of the perceived benefits that are offered by the technology. Furthermore, other research happened to hold the same opinion on this topic, which is the Technology Acceptance Model introduced by Davis et al. (Davis) in attempting to investigate why users accept or reject information technology. The original model indicates that one's acceptance of Information Systems (IS) technology is hypothesized to be determined by one's intention to accept it which is affected by his/her perception concerning its usefulness and ease of use. (see Figure 1-TAM model (Davis, et al., 1989).

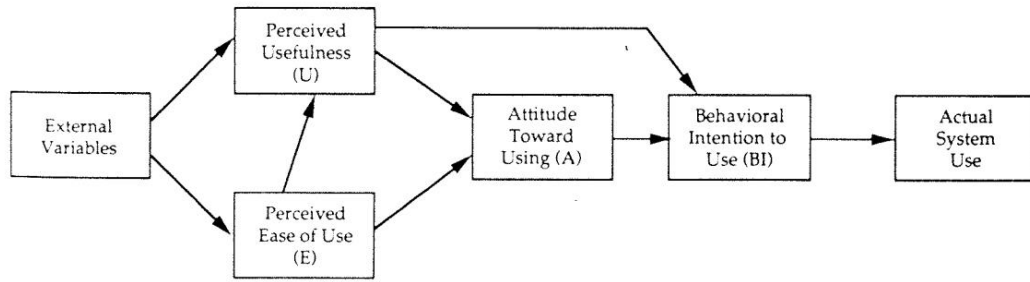

Figure 1 TAM Model

However, the TAM has been revised by Bernadette Szajna (Szajna, 1996) to provide a confirmation, and it has been further developed into an upgraded version concerning pre-implementation beliefs and post-implementation beliefs. In the pre-implementation version, participants were provided a brief interactive introduction to an IS, and the result shows that both usefulness and ease of use beliefs are depicted as having a direct effect on their intention to use technology (see Figure 2). It means, in this circumstance, one would rely on both their perceptions of usefulness and ease of use to form their intentions. In the other version, post-implementation, participants are given opportunities to actually use the IS for a period of time. The result is slightly different than the previous one. The ease of use belief is depicted as having an indirect effect on intentions, meaning once users have been using an IS, their subsequent intentions are formed from their perceptions of its usefulness (Szajna, 1996).



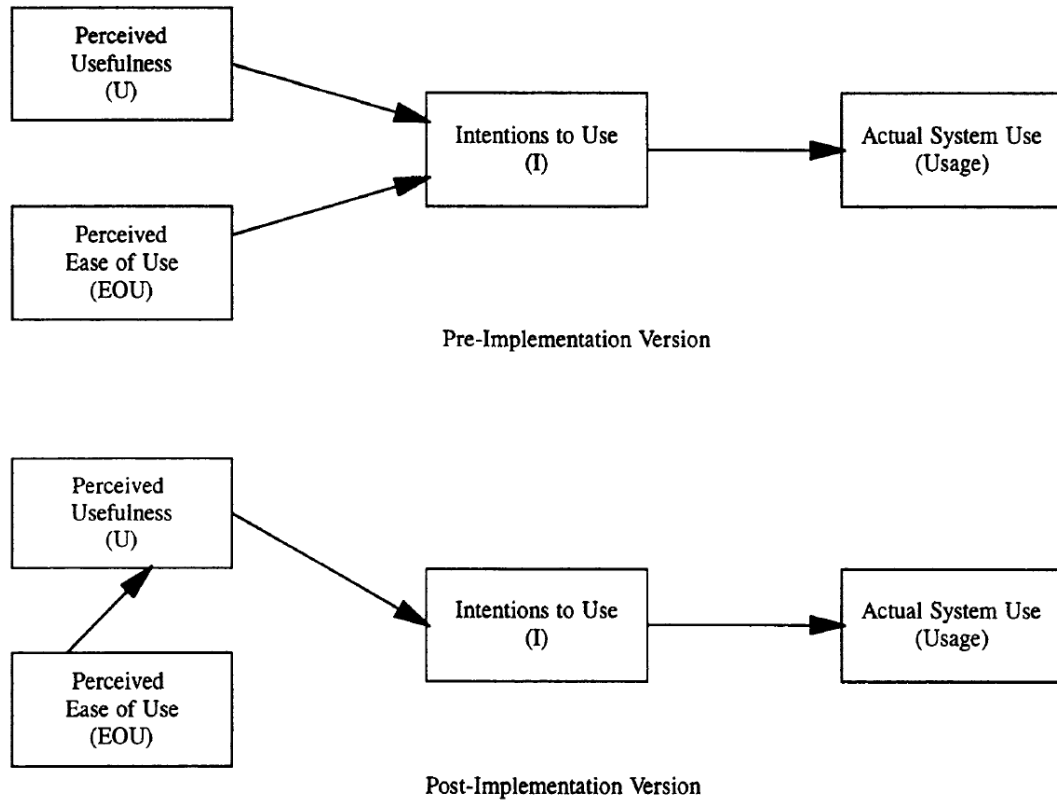

Figure 2

Both examples clearly indicate that older adult’s acceptance of technology seems to rely mostly on whether the benefits of technologies are clear to them and suited for their needs, and they seem willing to spend time, resources, and money as necessary to adopt new technologies if such clear benefits are perceived by them.

### Autonomy

There have been ethical issues of using automated system, mostly in the field of assistive technology (AT) for elderly. Most ethical objection debates appear around the view that people are, or should be, independent and self-determinant, and another, more applicable, approach to view people as social and reciprocal, meaning that the automated AT might cause loss of human contact and/or human care by creating long-distance care

relations instead of personal and intimate care relation.

On the other hand, proponents of AT often view its use as a way to promote independence and autonomy of elderly people, and plus that certain forms of AT promise freedom and autonomy for the older users. For example, need of informed consent for certain automated functions despite cognitive impairments may resolve the problems, such as older adults are unwilling to be restricted in their choice to take risks, and some do not want anybody to automatically know when they fall in their homes, because they would like to cope with this on their own sometimes. Moreover, some AT may increase older adult's autonomy by enhancing their confidence and safety in performing daily activities (Zwijssen, Niemeijer, Hertogh, & health, 2011 2011) For the latter point of view, some researchers pointed out that AT can also be used to extend social contact and improve the contact with professional, such as having video conferences (Zwijssen et al., 2011). More detailed discussion can be found in the literature conducted by Zwijssen, et al.,(2011) and the result indicates that ethical debate appears not to be a priority concern when it comes to use of AT in the care for elderly people living at home (Zwijssen et al., 2011).

### ***trust in automation***

Automated technologies developed to support the independence of elder people in their home must be reliable, and, at the same time, users must be willing to rely on it. A user's decision to rely on automated devices depends on their trust in the automated system and level of their confidence in ability to control the system. The trust is also dependent on current and prior levels of system performance, the presence of faults, and

prior levels of trust (Burdick & Kwon, 2004).

### ***privacy***

Since technologies are already being seamlessly integrated into people's daily activities, such as ubiquitous computing and monitoring systems, the issues of privacy should be raised in the product development. In monitoring system design, what types of information collected from users can be stored, transmitted, or shared with other people need to be explicitly determined. However, people's privacy concerns may change across different contexts, users, and even cultures. It is arguable whether safety or privacy is the most important issues. For example, people may be unwilling to hand over certain privacy in a non-emergency situation, whereas, in an emergency, part of their privacy might become of less concern. Most elderly people think that the needs for the devices overrule any possible privacy concerns, and as long as there is an appropriate balance between needs and privacy, they do not feel like their privacy is violated (Zwijssen et al., 2011),

Due to full understanding of the construction of privacy being beyond the scope and limits of this thesis, this topic will require further research to be analyzed in the future.

### ***conclusion***

Older adults are willing to adopt new technology, contrary to some stereotypes, if the benefits of the technology are clearly presented to them. Automated technologies can be applied to enhance the health, safety, independence, and quality of life of older adults with understanding the needs, capabilities, and limitations of user population. Privacy issues

need to be considered through product development depending on the context technologies being used and differences of individuals and cultures.

### **2.2.3 introduction to aging and technology**

Based on the age-related changes in both physical and cognitive abilities that have been reviewed in early chapters, the age-related differences in technology performance will be presented and related design solutions will be suggested in this section.

#### ***physical aging and technology.***

##### *visual perception.*

Visual difficulties among older adults, identified through research and literature review, are spatial vision (defined by acuity and contrast sensitivity), slowing of visual processing, seeing in poor light, visual search, and presbyopia. Based on the analysis, the implications are straightforward: if visual information is crowded by other visual stimuli, moving too quickly, presented at low contrast, or at the wrong viewing distance, older adults will have to make compensatory movements in using that information. The results are reduced accuracy, increased latency, and exacerbated visual fatigue (Burdick & Kwon, 2004).

The visual fields are reduced from approximately 180 degrees to 140 degrees by age 70 (Johnson, 1986). Furthermore, age-related reduction in the useful field of view (UFOV), the task-dependent spatial extent over which information can be extracted (Burdick & Kwon, 2004), has been found by many studies. When objects fall outside the UFOV, eye

movements are required to process a scene. To reduce the need for eye movement and assist older users, elderly-friendly designs should enhance the figure-ground segregation, reduce clusters, and keep target characteristics and location in particular consistent. (Burdick & Kwon, 2004)

Color is also critical to the use of visual space. Using color differences across a scene could help with the figure-ground segregation and help rapidly discriminate and identify objects (Burdick & Kwon). However, older adults will find technological applications using subtle color differences less accessible due to their indiscrimination. The understanding of both neural and optical reasons for which older adults have difficulties to process color information is that their abilities are finite. For example, the ability to distinguish between short-wavelength colors such as violet, blue and green is reduced in the elderly (Burdick & Kwon, 2004).

The longer light and dark adaptation period for older adults should be considered when there is possibility of environment changes in using technological devices. Hand-held devices have an advantage over fixed displays because the glare can be reduced or avoided by holding the device at a different angle. Better design solutions can offer automatic dimming functions that adjust the screen luminance to accommodate the environment change (Burdick & Kwon, 2004).

#### *auditory perception.*

Applications of sound technology are broadly used in our daily life. Devices like cell-phone, TV, and music player use the transmission of sound as the major method of

communication. Some healthcare devices use auditory alarm to notify users of upcoming events or when a safety parameter has been exceeded. Some more advanced systems, like Siri, Alexa and GoogleHome, recognize human voice commands and digitize them for records. All these devices that utilize auditory output need to consider the limitations of older users when they are included.

The common auditory problems reported by elders are slowing of auditory processing, hearing in noisy environments, understanding both normal and distorted speech, and hearing sounds of higher frequency (Burdick & Kwon, 2004PAG-23). Unfortunately, technology may exacerbate these problems because sound is being used as a means of communication under temporally demanding and noisy conditions where signal distortions are likely. For example, when using text-to-speech applications to allow for audio books while driving, the speech compression algorithms will increase temporal processing demands and shift the signal to higher frequencies, and the speech signal might need to be extracted from a variety of environmental noises. In this case, older adults will face numerous challenges because of both peripheral and more central changes in auditory processing (Burdick & Kwon, 2004).

Furthermore, the sound quality usually will be affected by variety of factors through the transmission of sound. For example, when driving through a tunnel, drivers often experience reductions or breakdowns in the quality of the voice transmission. Most of the sound signals have been compressed to save on bandwidth for the transmission, meaning certain frequencies are eliminated. These problems are annoying even for younger users; therefore it is likely to affect the usability of a device for older users. The detection of high

frequency sounds, such as discriminating “s” and “f”, will likely be impaired, as would the detection of high-frequency tones and beeps that are presented too quickly (Burdick & Kwon, 2004).

Another auditory technology related problem that needs to be considered in the product development is the computer-generated speech, which usually lacks the prosody and inflections used in normal speech that aid speech comprehension (Burdick & Kwon, 2004).

Temporal sensitivity is also significant when perceiving complex auditory signals such as speech and music. Several studies have found that temporal resolution reduces with age (Schneider & Pichora-Fuller, 2001). Consequently, older adults are less able to use inter-aural differences to distinguish a signal from noise (Burdick & Kwon, 2004), and this will impact speech recognition in noise, auditory scene analysis, and localization (Burdick & Kwon, 2004). However, the attentional mediated filtering of irrelevant information is found to remain the same for younger and older adults (Ison, Virag, Allen, & Hammond, 2002&Hammond,2002), and allocating one’s attention efficiently and appropriately to the task is as important as functionally processing audio information in auditory perception.

There are two methods that have been found useful for enhancing speech perception in the elderly. The first is the appropriate use of context. Older adults make as much or more use of semantic context to help with their speech recognition relative to the younger adults, and it might be because of the continuous use of and expertise with language. Yet, some developers might use abbreviated messages which reduces the context when

presenting speech signals in their application. This is likely to work against older listeners (Burdick & Kwon, 2004).

The second method is the appropriate modification of the complexity, enunciation, and timing of the speech signal. For example, Clear Speech, a method of speaking in a concerted effort to express every word, sentence, and idea in a very precise and deliberate way, can work well with older listeners. But it is important to ensure that Clear Speech does not devolve to “elder-speak”, a semantically simplified and effectively patronizing communicative style that is offensive to older listeners, and detracts from speech comprehension (Burdick & Kwon, 2004).

*touch and movement.*

Age-related sensory deficits include declines in sensitivity to pressure, vibration, spatial acuity, and the perception of roughness, length, and orientation (Burdick & Kwon). In addition, reduction of hand grip strength and range of motion due to changes in the joints and bones are also significant limitations to consider in the product development. For example, many older adults, especially those with arthritic conditions, have difficulty with technology-mediated motor tasks like keyboard entry (Burdick & Kwon, 2004). Difficulties with manipulating the stylus, buttons, and dials, as well as performing smooth and coordinate motor movements, are huge concerns in the use of technology by older users. Research has also found that reaching motions can cause pain to many older adults, which limits their ability to execute quick manipulations with arm movements. Therefore, it is important to keep device controls closer to the older users to avoid extensive reach



(Burdick & Kwon, 2004).

### **2.2.5 cognitive aging and technology**

#### ***Sensory***

Because age-related reduction of the speed of processing sensory information may influence older adult's task performance, slowing down, making lists, avoiding challenging circumstances, rehearsing key elements, and trying other memory aids would compensate this slowing of sensory processing. However, many age-related differences in technological task performances are not affected by only one cognitive factor and decline in sensory processing is often not the determiner that creates inability in use of technology.

#### ***working memory***

The wide use of automated telephone voice menus is a good example where age-related differences in working memory might impact an older adult's interaction with technology. A lot of companies use automated telephone menu systems to reduce human labor cost on customer services, such as banks, insurance companies, etc. People are required to memorize the menu options while attempting to make navigational decisions on the phone. If the menu system contains large numbers of options that must be considered before a choice can be made, older users might find themselves forgetting the content of the options because the reduction of their working memory capacity. In addition, if the age-related working memory declines due to slowing of processing speed, then the

speed of menu option presentation is another important factor to consider in the design development (Burdick & Kwon, 2004).

Design solutions derived from the cognitive aging literature can be: reduce the number of options needed to be considered in each level of the menu; and put the most desired options at the beginning of the menu to reduce the mental process to inhibit unwanted items. All the design solutions need to be carefully evaluated in the specific contexts they will be encountered to achieve the best performance of all users. For example, if slowing down the speed of presentation of menu options caused frustrations of users seeking speed and efficiency of menu navigation, then this design solution failed in bringing benefits to the users.

### *semantic memory*

Use of metaphor is an example utilizing specific previous knowledge from semantic memory to guide behavior in peculiar situations such as interacting with technology (Neale & Carroll, 1997). Therefore, design strategies that uses the existing knowledge base of older adults may result in more usable technology because device operation is more intuitive due to its consistency with prior knowledge(Burdick & Kwon). For example, the layout in the Windows computer desktop interface, where all the files and folders are organized mimicking traditional paper-based desktop work area, is a use of metaphor.

However, the use of metaphor can also be problematic and reduce usability of the device when the metaphor does not match user's prior knowledge base. Two approaches

can be deployed in solving metaphoric mismatch. One is to refine current metaphoric presentations to a more understandable version with which today's elderly users are familiar based on their prior knowledge base. The other solution is to develop a technology training to explicitly inform older users of the functionality of new systems that are inconsistent with their existing knowledge base (Burdick & Kwon, 2004).

### *prospective memory*

Medical personal digital assistants (PDAs) can be an example where technology guards against age-related declines in prospective memory. PDAs offer functions like reminding older users to take their medication at certain time, while the effectiveness depends on several factors such as the usability of the interface and older user's willingness to learn how to use such devices. As mentioned in the earlier sections, age-related changes in time-based prospective memory is greater than that in event-based prospective memory. Technology devices like PDAs can transfer a time-based task into a event-based task by including environmental support in forms of a physical reminder or cue that is specific to the task. In addition, because prospective memory task contains both time-based components and event-based components, the design solution needs to facilitate both to achieve satisfaction of users. In the PDA example, providing an environmental cue indicating that certain actions need to be done, and a visual display that provides specific instructions on how it needs to be performed, would increase the adherence of older users to the device (Burdick & Kwon, 2004).

### ***spatial abilities***

Based on findings from the cognitive aging literature, decline in spatial ability may cause unnecessary suffering in tasks that require high spatial ability such as navigation through a web site or an app menu. It is important to have easy access to desired information, as well as visually tracking user's location within the architecture of website or app for all users. Having a table of contents or navigation bar floating on the side to remind older adults of where they are and where the information is located can be helpful. Furthermore, such design intervention should also facilitate working memory in order to allow older adults to eliminate the necessity of remembering menu information. Design interventions that uses semantic memory should also compensate for decline in spatial abilities. For example, designers should construct the website or app in a way that keeps the organization of things consistent with expectations and prior knowledge base of older users.

### ***selective attention***

Driving a vehicle is an example of a task that is highly dependent on selective attention. Therefore, any potential distractions that would prevent drivers from focusing on important road cues may cause serious or even fatal problems. However, given findings in visual search literature, older adults can utilize environment cues to identify relevant information (Madden, 1983). In this case, actively providing environmental cues to enhance older adult's selective attention on relevant information can be helpful. Technology devices such as GPS and "heads up" display used as environmental cues to

guide older drivers while creating potential distractions at the same time should be carefully evaluated.

### ***reading comprehension***

Many medical devices require users to understand and perform a series of complex procedural tasks, so having readable instructions is often crucial in supporting usability of the device for older adults. Design suggestions in compensating reading comprehension include, but are not limited to, use of larger fonts to accommodate visual deficits, simplified sentence structure, and nontechnical terminology presented at a sixth-grade reading level at maximum (Wickens, Hollands, Banbury, & Parasuraman, 2015), and procedures should be explicitly stated so that older adults do not have to rely on inferential information (Burdick & Kwon, 2004).

## **2.3 design methodologies**

Industrial design being what it is practiced today is a heritage of numerous people including designers, artists, scientists, engineers, etc. and many turning points of the modern society. Generation after generation of designers strive to fulfill their job by creating products that improve people's efficiency, comfort, convenience, safety, and condition under which they live and work. Throughout the history of design, countless theories, approaches, and methods have been conceived and practiced in the design of people's everyday products. In this chapter, author will select and review some of the most effective and influential methodologies from which key methods and tools related to the topic of this thesis would be extracted to develop

the guideline of designing elderly friendly smart control devices.

### ***2.3.1 human centered design***

From the increasing complexity of automation system in the smart homes to the progressively decline of the physical and cognitive ability of older adults, every touch point between product and user can cause confusion, frustration and continued errors. Unfortunately, there are so many products with which people's home is inundated that were poorly designed, and therefore the product by which user's performance is supposed to be supported and improved becomes a source of difficulties and even hazards in performing activities. One of the solutions is Human Centered Design (HCD). Don Norman defined it as an approach that puts human needs, capabilities, and behavior first, then designs to accommodate those needs, capabilities, and ways of behaving (Don Norman, 2013). Many products have gotten better because of the implementation of HCD. However, new technologies, new applications, and new methods of interaction are constantly emerging and evolving, and the reality is that each new development seems to repeat the mistakes of the earlier ones, and each new invention of technology requires experimentation and study before the principles of good design can be fully integrated into practice (Don Norman, 2013). That's one of the reasons that author choose Human Centered Design as a foundation from which the design principles and methods of this guideline are derived.

### ***human centered design vs activity centered design***

Human Centered Design has become a dominant theme in design that is widely accepted

by interface and application designers automatically without doubt. When people talk about HCD, it is, most of the time, referring to the design of software products such as websites and Apps, and there are lots of books, courses, and articles on this topic in the field of UI/UX design. A key principle shared by most of UI/UX designers believing in human-centered design is “know your user”. In other words, one must have a deep and detailed knowledge of the people for whom the design is intended. The overabundance of bad designs seems to be a great evidence of ignoring the user, and it is indeed that usability and understandability of software products have been improved by emphasizing the needs and abilities of people who uses them. However, there are some critical problems with the usability in HCD. One of them is that the usability only can be defined in terms of the specific user group for which the system is being developed (Nielsen, 1994) because different user groups may require conflicting design solutions that would be applied on the same product. For example, a screen magnifier that bluntly increases the size of everything on the screen to compensate for the visual decline for elderly users may cause unnecessary and inefficient actions for younger users in performing the same tasks, which eventually leads to poor user experience. Furthermore, even for the same people, their needs may change over time. If designers only design for the individual of today, then the design could be ineffective tomorrow.

Besides, it is also difficult to define who the “user” is, especially when the “user” could be almost everyone. If it is so crucial to understand the particular user of a product, then how to design a product that is to be used by almost everyone? In this case, smart home devices, just like other everyday home appliances, are supposed to serve and assist with all the people within the house including both young and old, and it is a perfect example of category of

products that should be designed for wide range of users.

Every designer who believes in HCD must face the fact that there are many things designed without the user studies and methods of human-centered design that still work very well for everyone. For example, for most of everyday objects such as kitchen utensils, cameras, garden tools, etc., people all over the world manage to learn them and use them quite well. Even for something so complex like automobile, people tend to learn to drive quite successfully with roughly the same configuration of controls. This leads to another question that if people are able to adapt and learn the tools, then is it necessary for technology to always adapt to people? Looking back into the history, many successful technologies are adapted by people, and for some of them, people would put huge effort to adapt these tools. For example, musical instruments have existed all around the world for centuries. Most of them are complex and difficult to manipulate, and people spend years to learn instruments. Moreover, many musical instruments can cause severe medical problems such as repetitive stress injuries, which commonly appear among violinists and pianists. It is so severe that there are even books, physicians, and discussion groups devoted to these problems (Donald Norman, 2005). If designers run human-centered design test on every musical instrument, the majority of them would not pass. Does that mean majority of these instruments are bad designs? And why are these non-human-centered designs are still so successful?

Don Norman provided an explanation, which he called Activity Centered design, for these questions. He believes that a product should be developed with a deep understanding of the activities that were to be performed, and he says “ Successful devices are those that fit gracefully into the requirements of the underlying activity, supporting them in a manner



understandable by people” (Donald Norman, 2005). In his Activity Centered design theory, “activity” is defined slightly different than “task”: an activity is a coordinated, integrated set of tasks (Donald Norman, 2005), which means that one activity can contain multiple tasks. For example, a smart phone has a combination of tools such as text messaging, camera, reminder, and calendars supporting communication activities, and exchanging text messages and photos and checking events and date are tasks integrated into this device.

Activity Centered Design is actually similar to Human Centered Design, because the activities are, after all, human activities, which reflects the possible range of actions, the constraints of people, and conditions under which people are able to function. Therefore, a deep understanding of people is still a major part of Activity Centered Design (Donald Norman, 2005). So, what are the differences? There are three major differences between Activity Centered Design and traditional Human Centered Design: first is the mindset. The basic mindset of HCD is that technology should always adapt to people, being invisible and not getting in the way of the activities. Therefore, tools are developed to assist people or improve the performance of certain tasks, but the reality is that many activities are defined by the tools. People do adapt to technology, and technology has changed so many things in people’s life, from the way people eat, communicate, and play to the hours people sleep and work. Before the measurement of time was invented, people had a completely different pattern of sleep and work. As all above being said, one basic mindset of ACD is to learn the tools, and the activities are understood naturally.

The second difference is related to one of the weakness of HCD discussed in previous paragraph, which is that HCD focuses upon particular people or groups who can be diverse and

variable and have needs that are incompatible with others, while ACD focuses upon activities that is always clear and sequential. People are moving target, so when the design tries to predict the action of users and adjust itself accordingly, the chances to become successful wouldn't be so optimistic. In addition, too much attention to the needs of the user can lead to a lack of cohesion and added complexity in the design (Donald Norman, 2005). Sometimes, designers should be able to ignore some of user's needs when it's necessary. For example, Southwest Airline has two well know complaints of its passengers: not providing reserved seating and inter-airline baggage transfer. But Southwest decide that its major strategic advantage is inexpensive and reliable transportation, and this required a fast turn-around time at each destination. They let the passengers complain, and the passengers still come back (Donald Norman, 2005). The designers often have better reasons for the way they create the product/system, because they are more likely to look at the design from multiple perspectives. And ACD requires designers to have not only a deep understanding of the users, but also of the technology, of the tools and of the reasons for the activities (Donald Norman, 2005)

The third major difference is the methods of HCD. Many of the systems that have passed through HCD design phases and usability reviews are excellent at the level of the static, individual display, but fail to support the sequential requirements of the underlying tasks and activities. Because the methods of HCD tend to center around static understanding of each set of controls and each screen, the sequential operations of activities are often neglected (Donald Norman, 2005). A common situation that occurs in using HCD method is that even when all the details on a screen, including control buttons, icons, information, and other components have been improved, the overall performance of the application still remains inefficient and

unsatisfied.

The design process of activity-centered design is similar to human-centered design process broadly applied in the design field. They share the same framework (see Figure 3) but designers should use it with different approaches of pursuing the design goals. Due to the universal nature of the subject discussed in this thesis, designers need to understand the activity and the tasks that are required to support the activity, making sure that they work with one another seamlessly and the work done for one does not obstruct the need for another when following the process of human-centered design. One comment on the relationship between activity and tasks: one activity is constituted of a sequence of tasks, or consider them hierarchically as activity being a high-level structure, such as “enjoying music”, and tasks being a low-level structure, such as “discovering music”, “purchasing it”, “getting it into the music player”, “developing playlists”, and “listening to the music”.

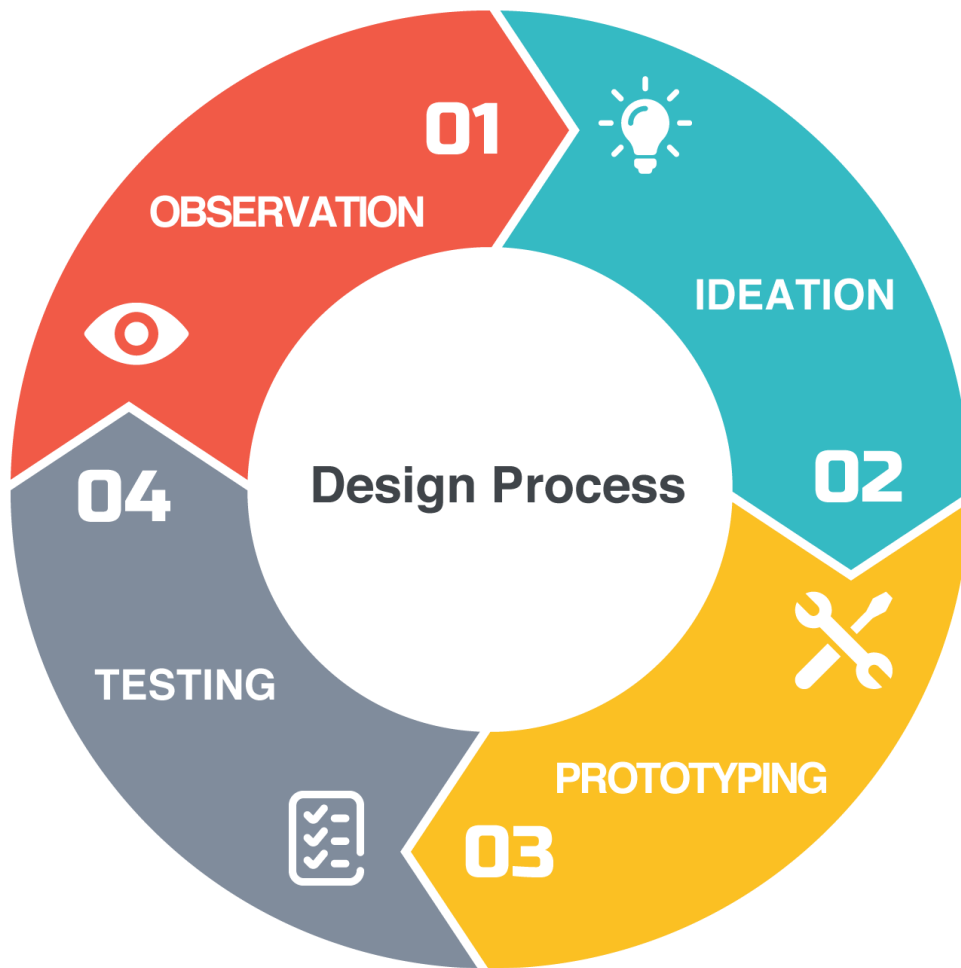

Figure 3 The human-centered design process

There are two critical principles considering this design process. First is to identify the right goal, which could be an activity or multiple activities that are correlated in achieving a larger goal. Setting up the right goal of a design project is the first and most important step. It is like the cornerstone of a project; all the other design decisions will be set in reference to it. Good designers would not start trying to solve the problem given to them; instead, they try to discover the real problems, because a brilliant solution to the wrong problem can be worse

than no solution at all (Don Norman, 2013). Thinking of everything as a system means all the elements involved in the system are interconnected. Sometimes, optimizing each individual element of the system might give an inferior result; therefore, discovering the final result of what people care of with a big picture in mind might be a better way to go.

Second, improving the design is not equal to adding new features, which occurs commonly in design practices today, especially for companies who are market-driven and engineering-driven, because adding features is, most of the time, adding complexity and creating confusion. A product/system serves a sequence of required tasks that together allows users to accomplish certain activity, so when new a feature is added, new tasks that could be performed become available. However, the problem is that not all new tasks are needed for the old activity; some might cause confusion or even conflicts on performing previous tasks for the users. A good design solution should optimize the task flow to make the activity more efficient and enjoyable, rather than creating confusion that leads to poor usability.

### ***experience design***

#### *what is experience design?*

The experience design can be defined as the practice of designing products, processes, services, events, and environments with a focus placed on the quality and enjoyment of the total experience (Don Norman, 2013). It has been brought up to people's attention in the design field for not a very long time. Before being a designer genuinely become an independent career like what we see nowadays, most designers were called "craftsman/artist" or "engineer", because people often think of design either in terms of aesthetic appeal or function. A well-

designed product should look good to the eye and feel good to the touch. At the same time, it should also deliver what it promises to do successfully, such as scissors should cut through a paper, or a screen should be able to display what it supposed to display. All of these can certainly be failures of design, because looking good and functioning well are not enough, much less the fact that “form” and “function” are not always compatible with each other. As a result, satisfying user experience becomes an explicit outcome of a good design, meaning that looking beyond the functional or aesthetic is necessary (Garrett, 2010).

In fact, experience design is really an ancient practice; rituals, ceremonies, drama, and even architecture are designed to provide certain forms of experience. It started to grow during the 20<sup>th</sup> century with the emergence of film and radio, and more recently with electronic media such as the internet, AR, and VR. “Different media showcase different types of experiences, but all share in the central importance of the experiences they evoke and concomitantly, the importance of effective design” (McLellan, 2000).

One important theory that supports experience design comes from economics, which is that our society has moved from a service economy to an experience economy according to Pine and Gilmore (Teska, 2001). An example of pioneer in this transition to an experience economy is the famous Walt Disney, whose economic value is based upon enjoyment and memorability rather than traditional concept of service (McLellan, 2000). The difference between service and experience is very subtle but significant. As Pine and Gilmore explain, “When a person buys a service, he purchases a set of intangible activities carried out on his behalf. But when he buys an experience, he pays to spend time enjoying a series of memorable events that a company stages—as in a theatrical play—to engage him in a personal way” (Teska,

2001). In this context, a company intentionally using its service as the stage and goods as aids to engage an individual is where the transition from service to experience takes place. And one of the characteristics of experience design is that the company would reveal the experience value to the customers over a duration of time (McLellan, 2000). The value of the product becomes the memorable and highly valued experiences in which people proactively engage and enjoy.

Table 3 is Pine and Gilmore’s model of the distinctions between agrarian, industrial, service, and experience-based economic activities (McLellan, 2000) Note the key attribute between service and experience-based economy shifts from customized to personal. This significant difference implies that a good design is more than delivering what customer wants or needs; furthermore, the design needs to have “personality” when it interacts with people.

<i>Economic offering</i>	<i>Commodities</i>	<i>Goods</i>	<i>Services</i>	<i>Experiences</i>
Economy	Agrarian	Industrial	Service	Experience
Economic function	Extract	Make	Deliver	Stage
Nature of offering	Fungible	Tangible	Intangible	Memorable
Key attribute	Natural	Standardized	Customized	Personal
Method of supply	Stored in bulk	Inventoried after production	Delivered on demand	Revealed over a duration
Seller	Trader	Manufacturer	Provider	Stager
Buyer	Market	User	Client	Guest
Factors of demand	Characteristics	Features	Benefits	Sensations

Table 3 *distinctions between agrarian, industrial, service, and experience-based economic activities*

*experience design in practice.*

People understand experience as a variety of things, such as sound, sight, feelings, thoughts, motives, actions, meanings etc., closely intertwined together. Most experiences are stored and labeled in the memory, but only some of them, especially the ones that contain strong emotions, are more likely to be recalled, relived and communicated to others, and these

experience can be both positive and negative. Creating pleasurable experience is an essential aspect of a good design; thus designers strive to develop the most elegant form, the most ergonomic grip, the most appealing color palettes, and the smoothest interaction. However, even if there is a product that achieves all the things above, it could still fail when the product behaves in an uninterpretable fashion which leads to confusion, frustration and even anger. When people interact with a product, they need to know what it does, how it works, and what operations are available. This is defined as “discoverability” by Don Norman (2013). He developed a tangible framework that helps designers to understand where and how experience is affected by carrying out a simple but in-depth analysis on the psychological process of human action, and a design tool was provided to identify where the design intervention should take place.

Every action has two parts involved: executing the action and evaluating the result, and both of them require understanding how the product works and what results it produces (Don Norman, 2013). These two parts can be broken down to seven stages (Don Norman, 2013):

1. Goal (form the goal)
2. Plan (the action)
3. Specify (an action sequence)
4. Perform (the action sequence)
5. Perceive (the state of the world)
6. Interpret (the perception)
7. Compare (the outcome with the goal)



These seven stages of actions are associated with three different levels of processing within the brain that is applicable to both cognitive and emotional processing:

1. The visceral level: this is the most basic level of processing, and it is tightly coupled to the body's motor system, and allows people to respond quickly and subconsciously, without conscious awareness or control. Emotionally, this is also what causes animals to fight or flee, or to relax (Don Norman, 2013).
2. The behavioral level: this is the home of learned skills, triggered by situations that match the appropriate patterns, and the most critical aspect of the behavioral level for designers is that every action is associated with an expectation (Don Norman, 2013).
3. The reflective level: this is the home of conscious cognition in which the deep understanding develops, reasoning and conscious decision-making take place (Don Norman, 2013).

Figure 4 is a visual demonstration of seven stages of actions and three levels of mental processing in which each level of mental process is associated with two stages of action.

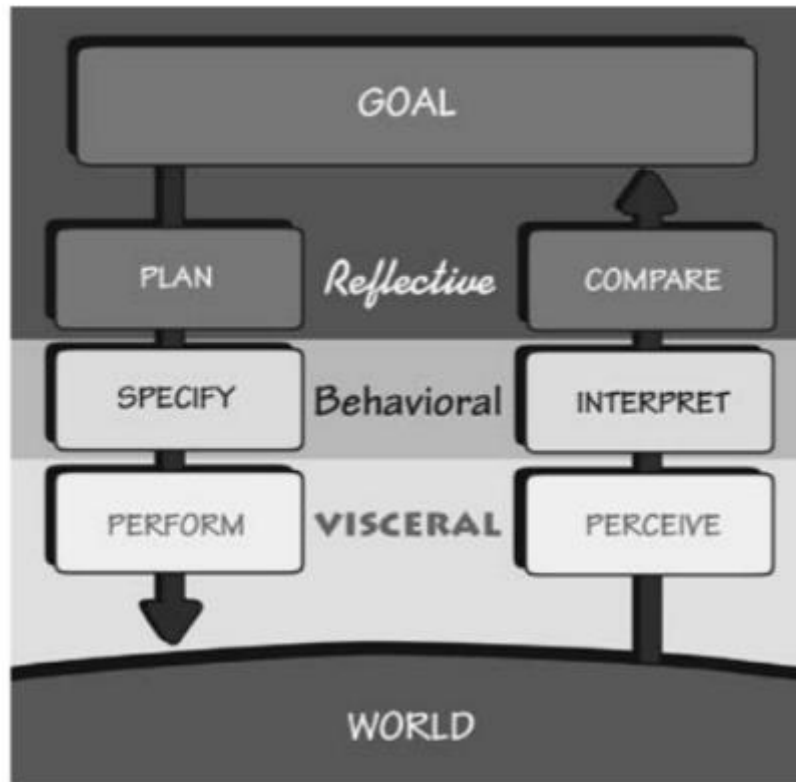

Figure 4

Understanding the human action is the beginning of this design process, so Don Norman also provided a design tool that is compatible with his action analysis. In this design tool, he uses five fundamental psychological concepts to guide design practices to create smooth and enjoyable interactions between users and the product. These five fundamental psychological concepts are:

- affordances- an affordance is a relationship between the properties of an object and the capabilities of the agent that determine just how the object could possibly be used.
- Signifiers-signifiers communicate where the action should take place.
- Constraints-providing physical, logical, semantic, and cultural constraints guides actions and eases interpretation.

- Mappings- the relationship between the elements of two sets of things
- Feedback-communicating the results of an action

This framework and design tool will be utilized in detail coupled with smart home control design in the Chapter 3 Design Guideline.

### *inclusive design*

When it comes to designing for elderly, the “universal design”, “design for all”, and “inclusive design” movement encouraged designers to extend the boundary and include older people in their design brief, but the issues that came with it is that designers tend to follow traditional design approaches to produce a concept design, and then only investigate on the older users to whom the product or system are modified to be accessible but practically unusable. In this situation, designs over tailored to cope with the needs of marginalized groups of people tend to be inefficient and sometimes inappropriate due to the fact that no one wants to be labeled as “old”.

The inclusive design approaches to usability of a product or system require that designers consider all potential user groups of systems, including minority groups, such as older people in this case. Therefore, the user groups may have too broad a spectrum of functionalities and characteristics to be encompassed within traditional user center design methodologies, and it is recommended that the methodologies of user center design be extended to form a paradigm supported by real world design practices rather than creating a whole new one (Newell, Gregor, Morgan, Pullin, & Macaulay, 2011).

For that reason, this thesis provides an example of incorporating human-centered design

and inclusive design approaches into the design of smart home control system in which everyone involved within the home, including older population, should be concerned. More details are presented in Chapter 3.

## **2.4 smart home control device**

### ***introduction to smart home.***

What is Smart Home? Many people may be vaguely familiar with the term “smart house” while most of them will not have a solid definition of what it is. Historically, it was first officially introduced back in 1984 by the American Association of House Builders when they created a special interest group called “Smart House”, whose aim was to include the necessary technology into the design of new homes (Dingli & Seychell, 2015).

The concept of “smart home” as practiced today did not spring magically out of the blue. In fact, it is a natural progression considering the concomitant emergence of massive advancement in technology throughout the 20<sup>th</sup> century (Dingli & Seychell, 2015). In the early 1900s, it was mainly about introducing vacuum cleaners and swing machines in the homes due to labor shortages. However, this movement greatly escalated the influence of technology in the society in the following years. Use of electricity became common among most households in the UK by 1940 (Dingli & Seychell, 2015). During the 60s and 70s, small electric products which are commonly appeared in the homes made the transition from being a luxury device towards becoming a necessity (Dingli & Seychell, 2015). The 80s and the 90s was the generation of the boom of commodity electronics such as TVs, Video records, DVD players, mobile phones, etc. (Dingli & Seychell, 2015). One of the turning points during this period is

that the notion of a home personal computer was widely accepted by the masses, and these personal computers, soon after, being connected to the internet opened the possibility of the smart home today (Dingli & Seychell, 2015). Then the concept of smart home evolved radically in the past decades because of the proliferation of the internet. Up to this point, some people believe that the current state of smart home is still far from ideal, because there are still many unresolved issues such as the reliability and efficiency in the sensory systems (Dingli & Seychell, 2015). In addition, new technologies that are expected to arise in the near future could change the game completely for the smart home industry. For example, the internet of things where all the devices start communicating with each other could be a significant technology breakthrough.

A home is considered to be smart because of how effectively it utilizes resources such as space, solar power, recycling systems, and, now, interactive technologies through ubiquitous or pervasive computing (Alam, 2012) that are implemented into homes, rather than how well it is built (Harper, 2006). According to an elaborated definition of a smart home that was published by Intertek in 2003, which was involved with the Department of Trade and Industry (DTI) smart home project in the UK, a smart home is a dwelling incorporating a communications network that connects key electrical appliances and services and allow them to be remotely controlled, monitored, or accessed (Alam, 2012). However, the definition of smart home is various, and it could mean different things for different people.

#### ***4 basic elements of smart home system***

It requires three things to make a home smart:

- Internal network- wire, cable, wireless
- Intelligent control- gateway to manage the featured systems
- Home automation – products within the home and links to services and systems outside the home (Alam, 2012)

For the practice of the design guideline, the author breaks down these three things into four basic elements to provide a basic framework of smart home system in which the design guideline would be adopted more easily. The four basic elements are:

- Network – allowing devices to communicate with each other as well as for the user to communicate with devices. It includes interconnected network, specialized network, and data network (Dingli & Seychell, 2015).
- Control – managing the systems by sending data or signal to control the actuators. Two types of control are included: control devices and virtual applications.
- Smart appliances – smart products that are connected into the smart home system.
- Sensor – collecting data from variety of sources, such as environmental parameters, healthcare data, and visual and audio data.

## CHAPTER 3

### DESIGN GUIDELINE

#### 3.1 Design Principles & Heuristics

All the design decisions for designing smart home control devices are guided by these fundamental design principles.

##### *benefit*

Perceived benefit and usability have been proved to be two most significant factors that affect the acceptance of new technology for older adults. Therefore, the benefit of each function, component, type of operation, and level of performance need to be clearly presented, so that it can be well preserved and understood by the user.

##### *accessibility*

Users are enabled to perceive, interact, understand, navigate, and contribute the tools, services, and products successfully without barriers.

##### *affordance*

An affordance is a relationship between the properties of an object and the capabilities of the agent that determine just how the object could possibly be used (Norman, 2013). For

example, a chair can be sat on or lifted up by people, and when people sit on it, the chair affords support, and therefore affords sitting. However, because affordance is a relationship, not a property, the chair is affording lifting when it can be lifted by a strong person or a group of people; while it is not affording lifting when a relatively weak person cannot lift it. Furthermore, affordance sometimes can be invisible, so a critical part of designer's job is to provide understandable and perceivable affordance which helps people figure out what actions are possible.

### ***low physical effort***

Users should be able to accomplish an activity with a minimum of interaction steps and a minimum amount of physical strength requirement, and the system should avoid unnecessary interventions by the user and function efficiently to reduce the likelihood of fatigue.

### ***low cognitive effort***

Design needs to enable users to focus on the actual task and reduce cognitive overhead needed to interact with the product, especially for older users in using technology with new kinds of interaction techniques because of the decline of cognitive abilities through aging process. In addition, extra non-automatic cognitive efforts can easily cause distractions during the interaction with the system, so that this may limit the value of a system for accomplishing certain sets of goals (Rizzo et al., 2005).

### ***learnability***



A low learning curve of the product/system can positively affect the acceptance of new technology and improve the usability. Limiting or eliminating the learning that is required by the product/system through the use of proper conceptual models that are developed from real world behavior or what the specific group of people for whom the designs are intended are already familiar with.

### ***consistency***

The interfaces of the product/system, including visual language, interaction techniques, and informational content should be consistent in order to reduce the confusion and improve the efficiency of product/system usage. The consistency of metaphors should also be carefully considered in designing interaction tools. For example, navigation that requires people to switch between the metaphor of tangible paper-based interaction (turning book pages) and that of computer-based interaction (scrolling pages) may cause problems for older users to perform the right action at the right time.

### ***flexibility in use***

Considering the diversity of user preferences and abilities, the product/system should provide flexibility in the ways of accomplishing user's goals. For example, this can be done by providing different modalities to accommodate individual user preferences such as one aiming to accomplish specific tasks and one supporting different interaction modes to offer more options for the users. Sometimes, different modalities can complement each other. For example, using multimodal inputs such as integrating speech and gesture interactions in furniture

arranging tasks can improve user performance, while each single interaction has its pros and cons. However, the tradeoff here is the increased complexity and flexibility of the product/system.

### ***responsiveness and feedback***

Response and feedback should be provided properly and in a timely manner to avoid frustration, confusion, and repetitive actions because users can only tolerate a certain amount of system lag. Designers should use feedback to minimize problems that are caused by poor responsiveness, such as showing the system status at all times, and making sure all the responses and feedbacks are perceivable, understandable, and not distracting users from their activities.

### ***error tolerance***

Designers should focus more on the situations where failure may occur during use of the product, not just on when it works as planned because this is where the opportunities of increasing user satisfaction come from. People experience a sense of achievement when they smoothly figure out the proper actions to solve the problem because the product highlighted the problem and made it understandable to the users.

## **3.2 Environment**

The Smart control is intended to bridge different technologies within the home and providing access from the home to external services as well as vice versa (Jiang, Liu, & Yang,

2004), so the environment where smart controls are applied comprises the users and other smart devices within the Smart Home Network.

### 3.2.1 Older users

#### *User Attributes*

##### *Age-related constrains*

Based on previous academic research and literature review that can be found in Chapter 2 for details, the author creates the following chart (Table 4) to provide a general overview of age-related differences that should be acknowledged and comprehensively investigated for the success of design practices in which older users are included.

Physical capability		General function	Common effects of aging	
VISUAL	Acuity	Static acuity	<ul style="list-style-type: none"> <li>• General decrease with age</li> <li>• Loss of acuity especially at limits of illumination levels</li> <li>• Smaller angle of peripheral vision</li> </ul>	
		Dynamic acuity		Discriminate detail in moving objects
	Accommodation		Ability to focus on objects at different distances	Difficulty with focusing on objects at close distances (presbyopia)
	Adaptation		Ability to see when changing from high illumination to low illumination or vice versa	Ability decreases particularly from age 60

	Color vision	Ability to distinguish between the standard color set	Color vision fades, particularly for blue-violet end of color spectrum
	Depth perception	ability to see how far away objects are	Affect eye-hand coordination
SUDITORY	Perception of frequency	<ul style="list-style-type: none"> <li>• Ability to hear sound of particular pitch</li> <li>• Ability to discriminate between sound of different pitches</li> </ul>	<ul style="list-style-type: none"> <li>• High loss needs louder sound to hear high pitched sounds</li> <li>• Decreases with age</li> </ul>
	Perception of intensity	Ability to hear sound at particular volumes	Generally higher thresholds
	Sound in signal-to-noise ratio	Ability to hear over background noise	Decreases with age
	Perception of complexity/harmony	Ability to perceive sounds of different complexities, e.g. pure tones (simple), speech (complex).	Speech perception decreases with age
MOTOR	Use of limbs	Ability to use limbs	<ul style="list-style-type: none"> <li>• Tremor</li> <li>• Osteoarthritis, caused by general wear and tear of joints due to aging</li> <li>• Lack of strength</li> <li>• Lack of sensitivity</li> </ul>
	Coordination	Ability to coordinate fine movement such as pointing at icons	Decreases with age
COGNITIVE	Long-term memory	(see chapter 2 for details)	Does not change with age
	Short-term memory		<ul style="list-style-type: none"> <li>• Decline with age</li> <li>• Korsakoff's psychosis</li> </ul>
	Information processing speed		Slows with age
	Attention/concentration		<ul style="list-style-type: none"> <li>• Affected by short-term memory</li> <li>• Pick's disease</li> </ul>
	Language comprehension		Effects vary based on different aspects of the

	Language production		tasks
	Planning complex actions		

Table 4 Age-related constrains

*Activities and tasks*

In Chapter 2, the author has come to a conclusion that the focus of designing smart home control devices should be the set of activities that are potentially carried out by using the product rather than the needs of individuals, because the smart home control device is supposed to be used by people across all ages. The following checklist should guide the design research:

Table 5, research on the list of activities that would be performed by using the device.

<b>NO.</b>	<b>activity</b>	<b>description</b>	<b>frequency</b>
1			
2			
3			
4			
5			
6			
7			

Table 5

Seven stages of action and three levels of processing:

- 1.What do I want to accomplish?
- 2.What are the alternative action sequences?
- 3.What action can I do now?
- 4.How do I do it?
- 5.What happened?
- 6.What does it mean?
- 7.Is this okay? Have I accomplished my goal?

Answering all the questions for each activity that is associated with the design and sorting them into the three levels of processing is necessary for the design (see table 6).

<b>Activity</b>	Watch movies	<b>duration</b>	2-3 hours
<b>What do I want to accomplish?</b>			
Enjoy a scary movie			
<b>What are the alternative action sequences?</b>			
<b>Sequences</b>	<b>Actions</b>		<b>Cognition</b>
1			
2			
3			

<b>What action can I do now?</b>		
<b>How do I do it?</b>		
<b>What happened?</b>		
<b>What does it mean?</b>		
<b>Is this okay? Have I accomplished my goal?</b>		

Table 6

Table 7 presents the differences between subconscious and conscious systems of cognition as reference for designer to determine what kind of design solution is applicable for each task.

<b>Subconscious</b>	<b>Conscious</b>
Fast	Slow
Automatic	Controlled
Multiple resources	Limited resources
Controls skilled behavior	Invoked for novel situations

Table 7

Use the five-fundamental psychological concepts to guide research and ideation process:

Affordances - define the affordances between required tasks and components of the product in the user research, and rank the concluded affordances based on the importance and demand of



each of them considering the needs of target users. For example, a chair affords sitting, lifting, and visually appeal. For a customer who wants to buy a chair, sitting might be essential affordance, and then visually appeal and lifting. However, a delivery man who is delivering a chair may rank the affordances differently. For him, being able to carry the chair by himself might be more important than the aesthetic features of this chair.

- Signifiers – based on the affordances that exist between product and users, designers should provide signifiers with which user would understand what and where actions are supposed to be performed and what alternatives are available. The designer should be aware that not all signifiers are deliberately placed on a product, or from another perspective, and not all signifiers have to be carefully planned. There are some natural signifiers, for example, one may use the thickness of the rest pages of a physical book to determine how much more reading is left. However, this natural signifier does not exist in electronic books; therefore, a planned signifier needs to be provided to support this need.
- Mappings – using spatial correspondence between the layout of the controls and the devices being controlled would make required actions easier to be understood by the users. For example, the seat adjustment control in a vehicle is in a shape of the seat itself, and the handling is straightforward that when people push the backrest part of the button forward, the backrest moves forward accordingly.
- Constraints – well designed constraints could guide actions, eases interpretation, and sometimes reduce the memory load for unfamiliar tasks which compensates the decline of cognitive ability through aging. LEGO is a great example for a good use of

constraints. The construction rules are suggested by providing the physical constraints that one cylinder fits one hole for all the pieces, and logical and semantic constraints provide strong restrictions on what would make sense for all pieces to go together without remaining any piece. Sometimes, culture constraints would be used to supplement the instruction of placement as well.

- Feedback – designers should use appropriate feedback to communicate the result of an action, because too much feedback can be worse than too little. All the feedback should be designed thoughtfully; otherwise, it could create confusion or even irritation to the users. For example, the annoying sound created by some chip readers to prevent consumers from leaving behind credit or debit cards often leads to a confusion of having transaction failure and triggers negative emotions right after the purchasing.

### **3.2.2 Smart Home Environment**

#### *categories of smart home appliances*

To define and demonstrate the characteristics of each category of smart home appliances, the author conducted a comprehensive product study on consumer level smart home products that currently exist in the market. All the findings concluded by author are based on customer reviews found in major media channels and official websites of the companies that are responsible for the products. These characteristics for each category can be used as market research guide for further product development or new product development.

*lighting*

### Types of Products:

- Smart light bulbs
- Smart light switches
- Smart light hub – a central control base that controls and connects to all the lighting items
- Smart plug – plugs that can be remote controlled

### Common features:

- Dimmable light bulb
- Light bulb works in fully enclosed fixture – it means if heat builds up inside the fixture it would not change the bulb's performance or shorten its life.
- Motion sensor – automatically turn on/off lights depending of whether activities are detected or not.
- Photocell – it turns off lights when daylight appears and turns back on when it's dark.

### Example product:

Philips Hue white starter kit (figure 5)



Figure 5

This smart lighting starter kit comes with two smart light bulbs and a control device called “bridge”. The light bulbs will be connected and controlled through the bridge by using the Philips’s app (figure 6), and all three items must connect to the home network, the Wi-Fi, to enable remote control. Because they are controlled by smartphones, voice control that was already built into the smartphone is also available. The app offers a hierarchical configuration to allow users to either control all the lights or each individual light. One feature that worth to mention is the geofencing feature, which can automatically turn on/off the lights based on the location of user’s phone. So, when people are coming back home or leaving home, the lights will turn on or off themselves.

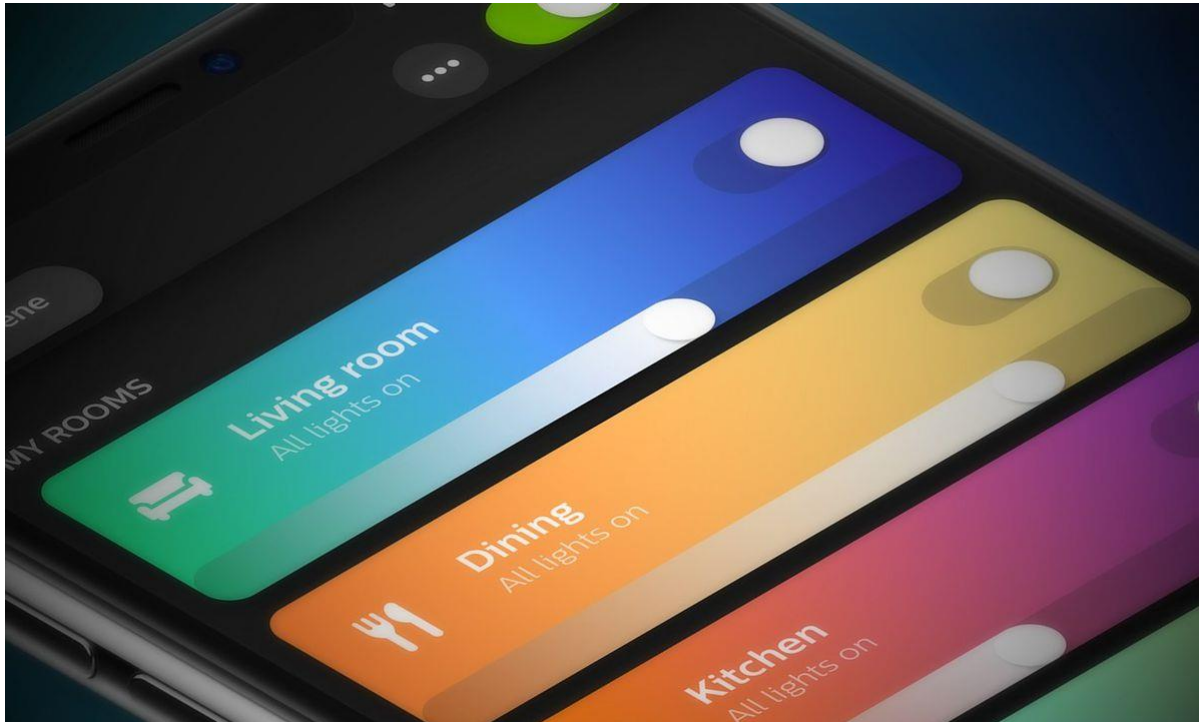

Figure 6

Main uses of products:

- Ambient lighting
- Mood lighting
- Remote control

*security and access control*

Types of product:

- Base stations – the brain of the security system;
- Contact sensors – physically attach to doors and windows to alert users when they are opened or closed;
- Motion sensors – detect the movement of people;
- Keypads/controller – input devices to enter access codes to arm and disarm alarm;

- Touchscreen control panels – similar to a tablet, act as a central control for alarms and other smart home devices;
- Key fobs and tags – similar to the key fob for vehicles, they have control buttons to the security system;
- Range extenders – increase the wireless range of the base station for larger homes.
- Security cameras – record footage when the alarm is triggered
- Sensors and Alarms – monitor home for fire, water leaks, extreme temperatures, and so on;
- Panic buttons – a quick and easy way to trigger alert for help;
- Smart lock – lock that allows people to open with their phones.

Common features:

- Voice control – many security systems support certain smart assistants, such as Alexa and google assistant;
- App controls – most home security systems come with an app so people can remotely control the system and receive alerts when they are away;
- Battery backup – most systems offer battery backups for power outage;
- Cellular backup – some systems may have cellular backup for internet outages.
- Duress codes – some security systems can alert the authorities without setting off the siren by entering a duress code

Example product:

SimpliSafe Essentials SS3-01 home security system



Figure 7

The product has been ranked as one of the top DIY home security kits in 2019 by multiple benchmark sources such as buying guides and consumer reports. The company offers several different kits designed around a centralized base station, and customers can build their own system with individual items such as a sensor, camera, key pad control, and key fob. The security kit comes with a 12-digit keypad as a controller (see figure 8), and it is reported to be cumbersome to use for typing in lengthy alphanumeric password from consumer reviews.



Figure 8

Main uses of the products:

- Fire and CO2 detection
- Flooding detection
- Home/apartment dwellers monitoring
- Intrusion monitoring

*home media system/service*

types of product:

- Smart TV – TVs that connects to the home network
- Speaker/sound bar/headphone – built in audio-based control system
- Set-top boxes – connect to the TV for streaming services and external control.



- Streaming stick – same as set-top boxes but in a smaller size.
- Media hub/portal – similar to a mini tablet, it works as a centralized control device with media functions built in the system
- Game consoles – specialized desktop computer used to play games.
- Other Audio/video devices – devices that can process audio and/or video input and output, such as projector, VCR, CD player, DVD player, etc.

common features:

- Voice control
- High speed for streaming devices
- 4K HDR capability for TV and streaming devices
- Universal search – more users prefer devices that can search across multiple services
- High sound quality for speaker – the standard of sound quality for smart speaker raised a lot recently because of the introduction of Google home max and Sonos One.

example product:

Amazon Echo spot



Figure 9

The amazon echo spot is an WiFi and Bluetooth wireless speaker with informative display. The Bluetooth connection allows it to connect and control another Bluetooth speaker, and WiFi enables it to control other smart devices within the home network. It visually and verbally communicates with users. For example, when it is plugged in it verbally states its ready for setup and plays a video tutorial during the setup.

Main uses of the product:

- Stream music/radio;
- Tell information about weather, traffic, date, time, etc.;
- Clock alarms/timer;
- Look up facts;

- Make calls
- Online shopping on Amazon
- Control other smart home devices
- Run third-party apps

### *temperature and climate*

types of product:

- Smart thermostat – can be remotely controlled by smartphones;
- Smart vent – controls the temperature in each individual room in the house by adjusting the air flow;
- Smart thermostat sensors – monitors the temperature and climate of the environment.

common features:

- Remote control
- Voice control
- Screens – shows prompts and digital controls
- Automated temperature changes – learn user's habits and set up routines adjusting temperature and climate based on different time or geo-fencing without manual programming;
- HVAC system support – support both cooling and heating systems

example product:

Ecobee Smart thermostat



Figure 10

With built-in Alexa, the Ecobee thermostat enhance has all of Alexa's features, including calling, messaging, and drop-in, and it also supports for Spotify, which means it can play background music on its speaker. The thermostat comes with remote sensors that can be placed in different rooms to monitor the temperatures.

Main uses of the product:

- Set temperature
- Schedule routine

- events/vacation setup
- Home/away access

*other smart home products*

types of product:

- Robot vacuum – automatically go off for vacuum and return for charging, and it learns the home’s layout
- Smart meat thermometer – sends alert to smartphone
- Fan – built-in WiFi, motion detection, and sensors for heat and humidity. It also can be remote controlled;
- washing machine – can be control by smartphones for selectin programs, adjusting temperature, delaying the start, etc.;
- refrigerator – monitors the food inside,
- Universal remote/hub – control multiple devices, such as TV, lights, speakers, etc., on one remote control/hub.
- Window covering – automatically open and close, and can be remote controlled
- Pet care – pet cameras, pet feeder, and pet toys;
- Smart bed – tracks people’s sleep and show analyzed data on smartphone
- toys

***Conclusion***

Use the following check list table to list out all the devices that is in the smart home

network. (table 8)

<b>Lighting</b>	
<b>security and access control</b>	
<b>home media system/service</b>	
<b>temperature and climate</b>	
<b>other smart home products</b>	

Table 8

### 3.3 Components

The author created a list of components that would potentially appear in a smart control devices/system with design suggestions considering the needs and constrains of users, especially for users with older age.

Table 9 below is an overview of all the components and where the applications of them are applied in the design project in chapter 4.

<b>3.3.1</b> weight & dimensions & location	3.3.1.1 Mobile devices	3.3.1.2 Stationary devices			
4.3.1					
<b>3.3.2</b> Composition	3.3.2.1 Hierarchy	3.3.2.2 Focus	3.3.2.3 Layout		
4.3.2					
<b>3.3.3</b> Control	3.3.3.1 Physical control	3.3.3.2 Virtual control			
4.3.3					
<b>3.3.4</b> Display	3.3.4.1 selection and design	3.3.4.2 Illumination			
4.3.4					
<b>3.3.5</b> Typography	3.3.5.1 Size	3.3.5.2 Typefaces	3.3.5.3 Text backgrounds		
4.3.5					
<b>3.3.6</b> Iconography	3.3.6 standard	3.3.6 geometric	3.3.6 Size and padding		
4.3.6					
<b>3.3.7</b> Color	3.3.7 Contrast	3.3.7 Tool			
4.3.7					

<b>3.3.8</b> Interaction	3.3.8.1 gesture	3.3.8.2 Sound/voice			
4.3.8					
<b>3.3.9</b> Communication	3.3.9.1 navigation	3.3.9.2 feedback	3.3.9.3 Help & assistant & error	3.3.9.4 writing	3.3.9.5 Visual cues
4.3.9					
<b>3.3.10</b> Onboarding	3.3.10 Self-setup	3.3.10 Quick start	3.3.10 User benefit		
4.3.10					

Table 9

### ***3.3.1 Weight & Dimensions & Location***

#### *3.3.1.1 mobile devices*

For mobile control devices to be held by or attached to user's hand or arm, designers need to consider the reduction of hand strength and arm strength for older users, because as the user gets old:

Their **hand strength reduces about 16-40%**;

Their **arm strength reduces about 50%**.(Tilley, 2002b)

Making the product too large or too heavy may cause problems such as creating muscular soreness, manipulation difficulties, performance decline, experience of hard to pick up and easy to drop. Designers can avoid such problems by:

- Enhancing the grip area;
- Minimize the weight of the product;
- Minimize/avoid two-hand control/manipulation;
- Providing assistive components which require little hand strength/arm strength.



If the device has screens, the screen size should not be too small that reduces the legibility of presented information, because older people needs larger visual details. On the other hand, it also should not be too large, because users who are in older age would have trouble operating it properly and experience usability problems. Determine the overall size of the control device based on the following anthropometry data (Tilley, 2002a):

- Index finger width

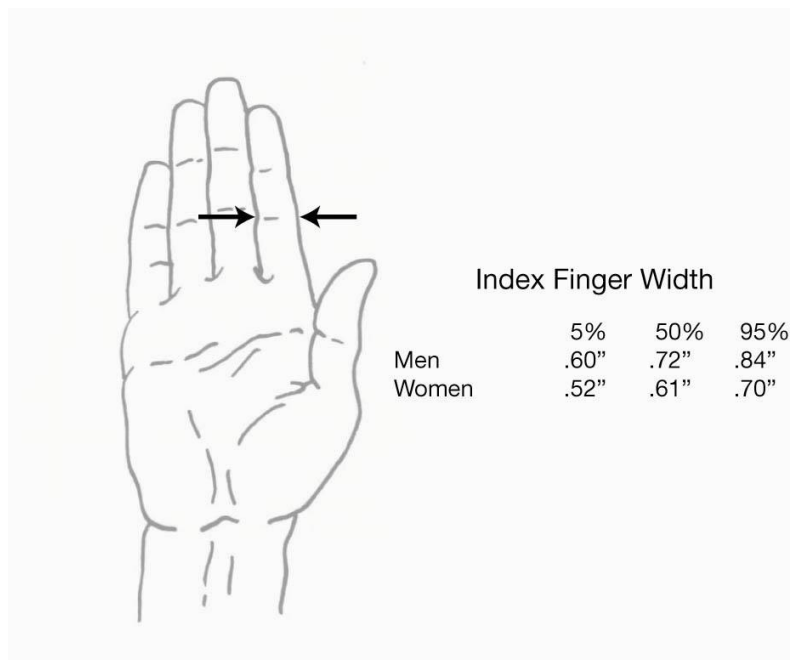

Figure 11

- Hand length

	5th%	50th%	95th%
Men	6.29"	7.08"	7.67"
Women	5.71"	6.49"	7.08"



Figure 12

- Hand breadth

Hand Breadth			
	5th%	50th%	95th%
Adults			
Men	3.1"	3.4"	3.8"
Women	2.7"	3.0"	3.4"
Elderly			
Men	3.1"	3.3"	3.6"
Women	-	-	-

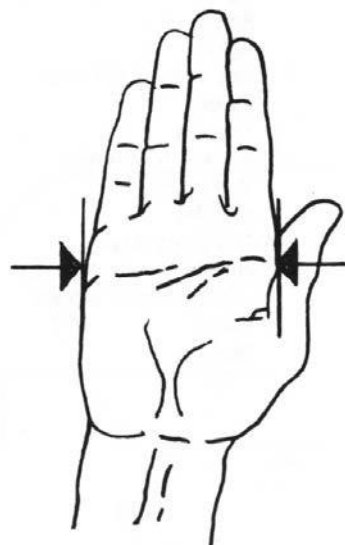

Figure 13

### 3.3.1.2 stationary devices

Wall-mounted devices should be placed around the standing shoulder height for the elderly (see figure 14) because older adults:

May have **smaller peripheral vision field**;

May have **joint stiffness and tremor**(Nicolle & Abascal, 2014).

So, designers should consider:

- Both anthropometry of men and women;
- Optimum zone for controls;
- Preferred visual angle.

For desktop devices, designers should consider:

- Both anthropometry of men and women;
- Preferred display zone;
- Standing low reach height;
- Providing adjustable components that allows users to set up the device

according to their own preferences.

For larger devices, the location of controls should be limited within:

- The optimum zone for controls;
- Area between high reach and low reach;
- Reachable area on the tabletop surface.

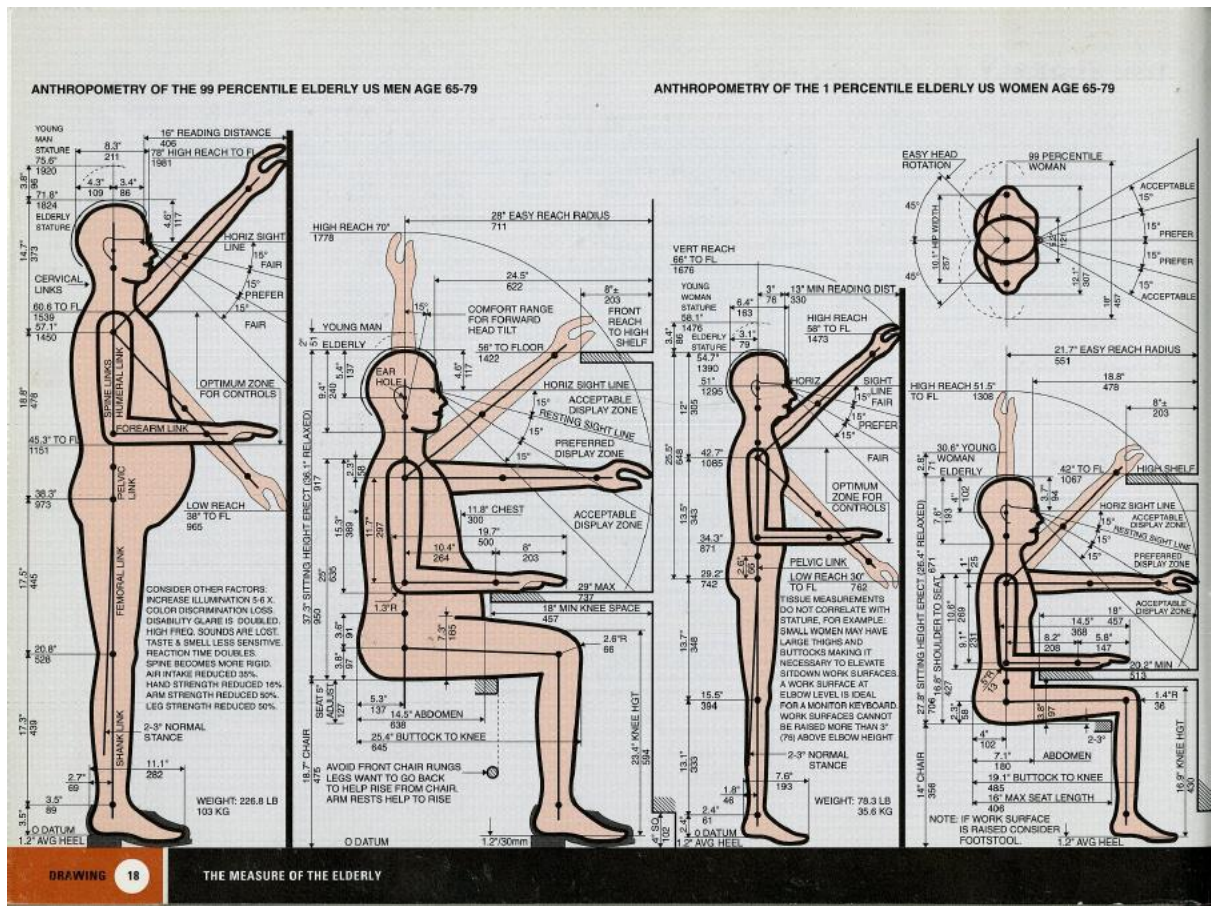

Figure 14

### 3.3.2 Composition

Good composition of a user interface should give users confidence in knowing what's important, what actions are allowed/needed to perform, and what is happening through hierarchy, focus, layout, texture, form, and group.

#### 3.3.2.1 Hierarchy

Every added button, images, and line of text increase the complexity of the user interface, and this may cause frustration and confusion for the users, which eventually leads to poor user experience. Designers can simplify how the designs are perceived by using:

- Clearly visible elements/cues
- Sufficient contrast and size
- A clear hierarchy of importance
- Key information that is discernable at a glance

Place items on the screen according to their relative level of importance, due to the **decrease of visual information processing speed** and **decline of working memory** for older users:

- Important actions: place important actions at the top or bottom of the screen (reachable with shortcuts),
- Related items: place related items of a similar hierarchy next to each other.

### *3.3.2.2 Focus*

Input focus should follow the order of the visual layout which is from top to bottom of the screen, and it should traverse from the most important to the least important items. Designers need to determine the following focus points and movements:

- The order in which elements receive focus
- The way in which elements are grouped
- Where focus moves when the element in focus disappears

Focus traversal between screens and tasks should be as continuous as possible. If a task is interrupted and then resumed, place focus on the element that was previously focused (Google, 2019).

grouping

- Keeping related items in proximity to one another is helpful for those who have low vision or have trouble focusing on the screen.

### 3.3.2.3 layout

consistency

- Consistency across physical components and digital components are encouraged by using uniform elements and spacing;
- User interfaces should use intuitive and predictable elements;
- Use consistent grid, keyline, and padding.

activity-centered

- Use the activity-centered design kit provided in the previous section to analyze and design the sequences of tasks that are required by the activity;
- Place elements and controls in close proximity to allow sequential operations to flow smoothly;
- Arrange elements and controls of similar function together;

responsiveness

- Digital layouts should be adaptive and react to input from user, device and

screen elements;

- Digital layouts may change as the screen sizes change across platforms.

### **3.3.3 Control**

#### **3.3.3.1 Physical Control**

Static features:

- Provide unambiguous signifiers for each control to communicate where the action should take place;
- Be cautious with controls that contains multiple functions, and make sure each function is perceivable for users;
- Offer sufficient clearance between adjacent controls, so that they can be easily manipulated;

Shapes:

- Use the right shape that is compatible with the required action or motion for a control;
- Increase the depth and add serrations on knobs that are small in diameter;
- Use a larger knob that allows user to manipulate it with all their fingers if precise knob rotation is required;

Dimensions

The following suggestions are proposed for a variety of types of dimension of controls:

- Reduced range of motion should be considered for designing rotational control
- Diameter of round knob should not be less than 1 inch, and the depth should not be less than 0.5 inch (Woodson, Tillman, & Tillman, 1992)

Force

Considering the decline of body strength through aging, designers could:

- Apply high resistance force for controls that are intended for short amount of time;
- Apply low resistance force for controls that are used for long period of time or in high frequency;
- Plan for the slip actions and mistake actions that may be applied on controls by users;
- Controls should withstand great forces in case of extreme situations happening;
- Resistance for rotational knobs should be less than 6 in-oz due to decrease of hand strength of older adults (Woodson et al., 1992);

### 3.3.3.2 *virtual control*

Touch targets:

- Touch targets are the parts of the screen that respond to user input. They extend beyond the visual bounds of an element. For example, an icon may appear to be 24 x 24 dp, but the padding surrounding it comprises the full 48 x 48 dp touch target.
- Make sure buttons and selectable areas are of sufficient size for users to easily touch them, especially for critical actions. They should be at least 48 x 48 dp. A touch target of this size results in a physical size of about 9mm, regardless of screen size. The recommended target size for touchscreen elements is 7 to 10mm. It may be appropriate to use larger touch targets to accommodate a larger spectrum of



users.

Touch target spacing:

- In most cases, touch targets should be separated by 8dp of space or more to ensure balanced information density and usability.

### ***3.3.4 Display***

#### *3.3.4.1 Selection and design*

Designers should consider the complexity, accuracy, user convention, and effectiveness when selecting or designing a display:

- Use the simplest display concept commensurate with the information transfer needs of the users;
- Use the least precise display format that is commensurate with the readout accuracy actually required and/or the true accuracy that can be generated by the display-generating equipment;
- Use the most natural or expected display format commensurate with the type of information or interpretive response requirements;
- Use the most effective display technique for the expected viewing environment and operator viewing conditions (Mejdal, McCauley, & Beringer, 2001).

Optimize the following display features:

- Visibility;
- Legibility;

- **Conspicuousness:** Ability to attract attention and distinguishability from background interference and distraction;
  - **Interpretability:** Meaningfulness to the intended user within the environment
- (Mejdal et al., 2001).

#### *3.3.4.2 Illumination*

Unlike stationary controls, portable control devices can be used in different lighting environments, and user may face difficulties of viewing screen content when they encounter a shift of lighting environment, for example entering the house from the balcony. Especially for older users, it takes longer for them to adapt light and dark, so the suggestion for this factor could be:

- using sensors to monitor the ambient lighting environment so that the screen would adjust its luminance and contrast automatically
- or provide easy access controls that allow users to adjust the screen luminance and contrast

#### *3.3.5 Typography*

##### *3.3.5.1 size*

- Increasing the font size does help with comprehension and reading speed, but if the size of text is too large, either users will be forced to scroll to find needed information or designer will need to consider eliminating unnecessary information.

- The recommended font size for body text is 16pt, which is about 5.6mm in a physical size (Kärkkäinen & Laarni, 2002).

### 3.3.5.2 *typefaces*

There is a typeface standard for signage systems set by the Americans with Disabilities Act (ADA) recommending the appropriate body-width to height and stroke-width to height ratios, that can be useful in regard to typeface selection for the aging eye:

- Body width = 60% to 100% of height
- Stroke width= 10% to 20% of height (Nini, 2006)

More in-depth research done by the professional association for design (AIGA) studied several typefaces that meet the ADA requirements for use in signage systems. They compared each typeface with its simulation in which the image of the typeface is modified into how it would be seen by a viewer experiencing a loss of light and focus. The following conclusions can be set in typeface selection for this guideline:

Comparing Bodoni Book and Times Roman - the characters tend to break apart under low vision conditions when the stroke areas are thin; the larger x-height and less thin stroke areas of Times Roman slightly improve readability, and the somewhat condensed proportion results in closed counterforms under low vision conditions, such as in the “e” and “a”.



Bodoni Book (left) and Times Roman (right)

Comparing Garamond Semibold and Century Schoolbook - the more consistent stroke width and wider proportion help readability; small counterforms in the “e” and “a” tend to close under low vision, but wider proportion helps the counterforms to close less; and more consistent stroke weight and larger x-height improve readability in low vision.



Garamond Semibold (left) and Century Schoolbook (right)

Comparing Glypha Roman and Futura Heavy – slab serifs make each character slightly more distinct; simple circular forms seem to remain visible well in low vision, but the short crossbar of the “t” does fall away in Futura Heavy.



Glypha Roman (left) and Futura heavy (right)

Comparing Helvetica Bold and Univers 65 – larger x-height and wide proportions help readability under low vision, but shorter ascenders and descenders do not hold up as well.



Helvetica Bold (left) and Univers 65 (right)

Comparing Frutiger Bold and Syntax Bold – the fairly wide proportion, open counterforms and slightly longer ascenders and descenders all seem to improve readability.



Frutiger Bold (left) and Syntax Bold (right)

Conclusion:

- Consistent stroke widths
- Open counterforms
- Pronounced ascenders and descenders
- Wider horizontal proportions
- More distinct forms for each character (such as tails on the lowercase letters “t” and “j”)
- Extended horizontal strokes for certain letterforms (such as the arm of the

lowercase letter “r” or the crossbar of the lowercase letter “t”)

### 3.3.5.3 text backgrounds

- Black text is recommended for use on light backgrounds, and white text on dark backgrounds;

- Use white or black text and icon with reduced opacity on colored background to create better contrast instead of using gray text and icons;

For example, black text displayed at 75% opacity on a red background gives the text an appearance of black, with a hint of red.

- Alternatively, designer can calculate the color of text by doing the following:

1. Place the color black at reduced opacity in front of a red background
2. Identify the hex value of the resulting darkened red color
3. Use that hex value of that color for the text

In this case, if the surface behind the text changes color, the system must update the hex color as well.

- Dark text/icon on light background are recommended to apply the following opacity levels:

1. High-emphasis text/active icons have an opacity of 87%
2. Medium-emphasis text/inactive icons and hint text have opacities of 60%
3. Disabled text/disabled icons have an opacity of 38%
4. Default error helper text has a hex value of #B00020 at 100% opacity

### Colored Text

Colored text should be used sparingly to draw attention and apply selective emphasis. Ideally colored text should be reserved for text elements such as headlines, buttons, and links (Google, 2019).

### Selected Text

Selected text should be legible against the selection color, and the selection color should contrast the background color. Alternatively, Designers can display outlines, motion, checkmark icons, or other text treatments to indicate selected text (Google, 2019).

### ***3.3.6 Iconography***

Icon is a significant visual signifier that symbolizes common actions, files, devices and directories, and the following suggestions are proposed by author to guide the designs of system icons considering needs and constrains of older users:

- Use universal icons for prevalent elements such as “setting”, “menu”, “search”, etc.
- Recommended icon shapes are bold, geometric, and consistent shapes. Avoid thin and delicate stroke weights;
- The recommended system icons are displayed as 24 x 24 dp, but it may be scaled down to 20 dp when external input devices, such as mouse and keyboard, are the primary input methods .(Google, 2019)
- A 2dp of empty padding space surrounding the icon is recommended to reduce the

likeliness of being hidden by other elements, such as side bars when they appear upon scrolling, or the limited screen boundary (Google, 2019).

- Use basic shapes for icon design;
- Use icon grid and keyline to maintain consistent visual proportions across system icons. There is a preset standard determined by Google for specific keyline, including the circle, square, rectangle, orthogonal, and diagonals, available for reference (Google, 2019);
- Do not distort an icon;
- Use consistent stroke weights and squared stroke terminals;
- Avoid tilting, rotating, or making 3D icons;
- Keep the icon simple.

### ***3.3.7 Color***

Due to the **yellowing of lens** through aging, designers should make color choices more thoughtfully, especially for small icons and graphics that contain low color contrast steps between short-wavelength colors:

- Be careful when using short-wavelength colors, such as violet, blue and green;
- Recommend longer-wavelength colors, such as yellow, red, and orange.

#### ***3.3.7.1 color contrast***

The contrast ratio between a color and its background ranges from 1 to 21 based on its luminance (the intensity of light emitted) according to the World Wide Web Consortium (Note,



2016).

The W3C recommends the following contrast ratios for body text and image text:

- Small text should have a contrast ratio of at least 4.5:1 against its background.
- Large text (at 14 pt bold/18 pt regular and up) should have a contrast ratio of at least 3:1 against its background. (Google, 2019)

### *3.3.7.2 color tool*

A color tool provided by Google is a good resource for designers to create, share, and apply color palettes to the UI, and measure the accessibility level of any color combination.

## **3.3.8 Interaction**

### *3.3.8.1 gestures*

There are three types of common gestures: navigational gestures, action gestures, and transform gestures. Navigational gestures help users to navigate through a product easily; action gestures can perform actions or provide shortcuts for completing actions; and transform gestures are used to transform an element's size, position, and rotation with gestures.

The following suggestions need to be taken in to consideration when developing gesture control for the product/system:

- gesture control should not be the only way of performing a task; other methods of control needs to be available when the gesture fails.
- Avoid requiring precise movement or tapping for gestures due to the lack of coordination, tremor, and joint stiffening that occur in aging.

- If there is standardized gesture for specific operation, it should be adopted as the priority option. Use existing gestures rather than create new ones unless it is necessary (Google, 2019).

### *3.3.8.2 sound/voice*

There are three major types of sound that can be used in the smart control system, which are plain sound, music, and computer-generated voice. They can be used separately or together to create particular effects in the same UI context, and each of them communicates information in different ways. Consider the following suggestions for designing sound:

- Plain sound can be used to associate a UI element with a specific sound, express emotion or personality, convey hierarchical structure by associating interactions with certain sound, and provide sensory feedback (Google, 2019).
- When using sound as a sensory feedback, avoid use of high-frequency sound, because it is less likely to be perceived, especially for older users. For example, the sounds of “s” and “f” are hard to be discriminated, as well as the detection of high-frequency tones and beeps, which are commonly used due to its low cost for producing such sound, would be presented too quietly to elderly people.
- Music can be used for emotionally resonate contexts and providing moments of delight (Google, 2019).
- Similar to the automatic adjustment for screen illumination, an option of automatically adjusting volume depending on the level of ambient noise would be recommended;

- Computer-generated voice is commonly used to communicate complex information, provide conversation and dialogue, and enhance personality (Google, 2019). It can be used on where sound and music cannot support the needs of certain tasks but avoid using it for critical/emergency messages due to its complexity;
- Keep the message simple, but minimize abbreviated messages;
- Considering the age-related changes in auditory processing and decline of cognitive ability, designers should appropriately use of semantic context if possible.

### **3.3.9 Communication**

#### *3.3.9.1 navigation*

Navigation is the act of moving between screens to complete tasks (Google, 2019).

Based on the system's information architecture, a user can move in one of three navigational directions:

- Lateral navigation: refers to moving between screens at the same level of hierarchy. The primary navigation component should provide access to all

destinations at the top level of its hierarchy.

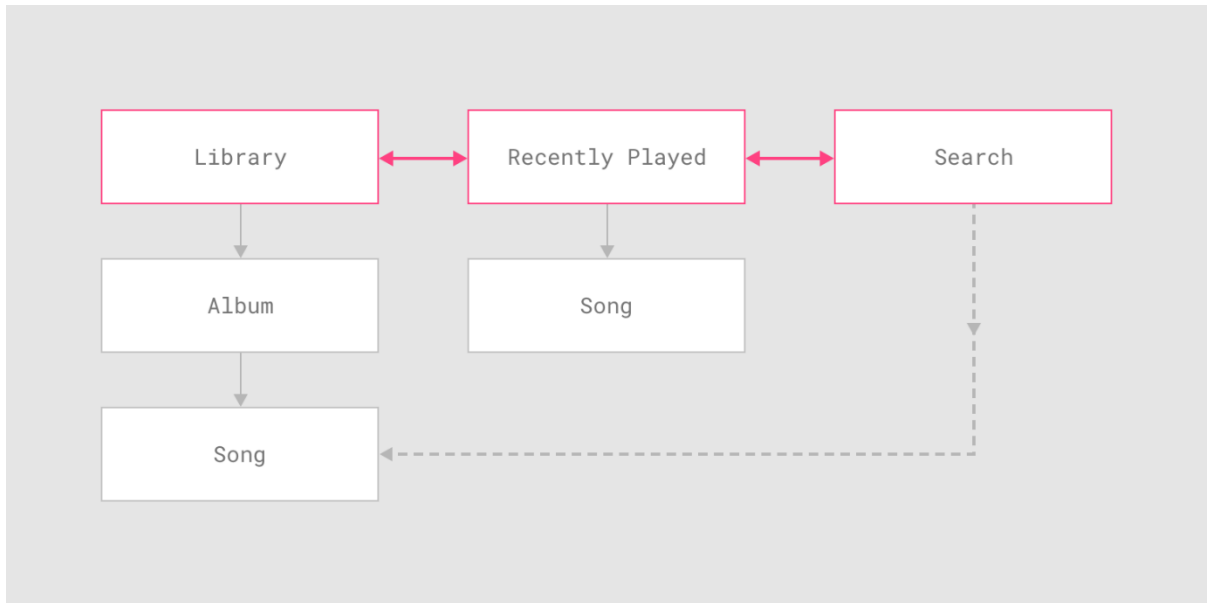

Figure 15 Lateral navigation

•Forward navigation: refers to moving between screens at consecutive levels of hierarchy, steps in a flow, or across system. Forward navigation embeds navigation behavior into containers (such as cards, lists, or images), buttons, links, or by using search.

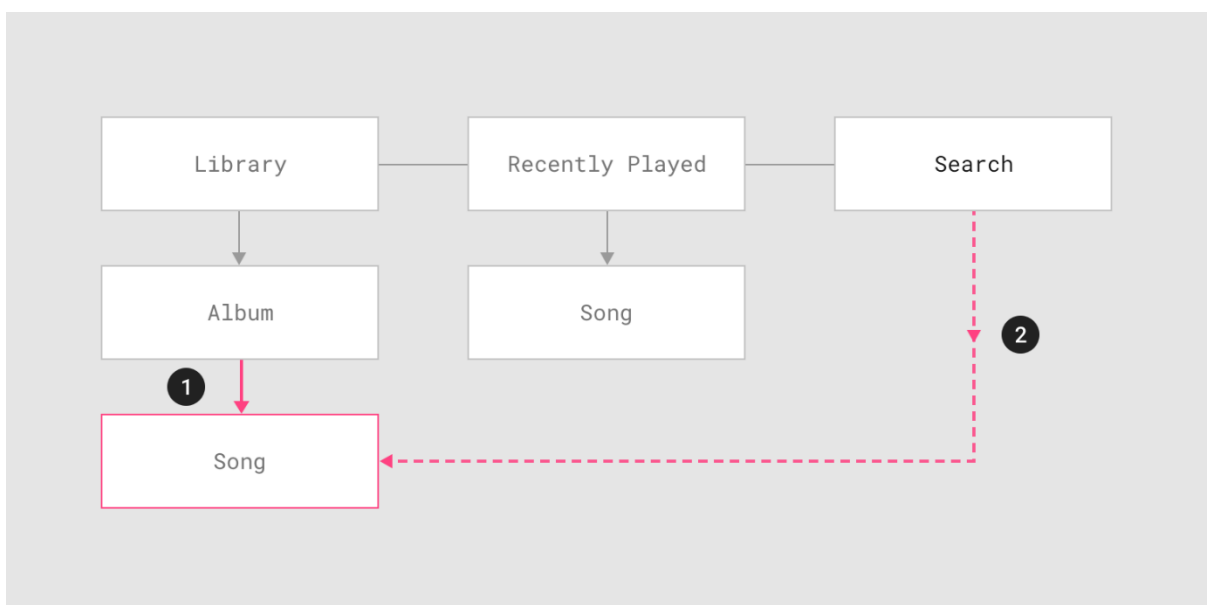

Figure 16 Forward navigation

- Reverse navigation: refers to moving backwards through screens, clearly marked exits and back button should be provided.

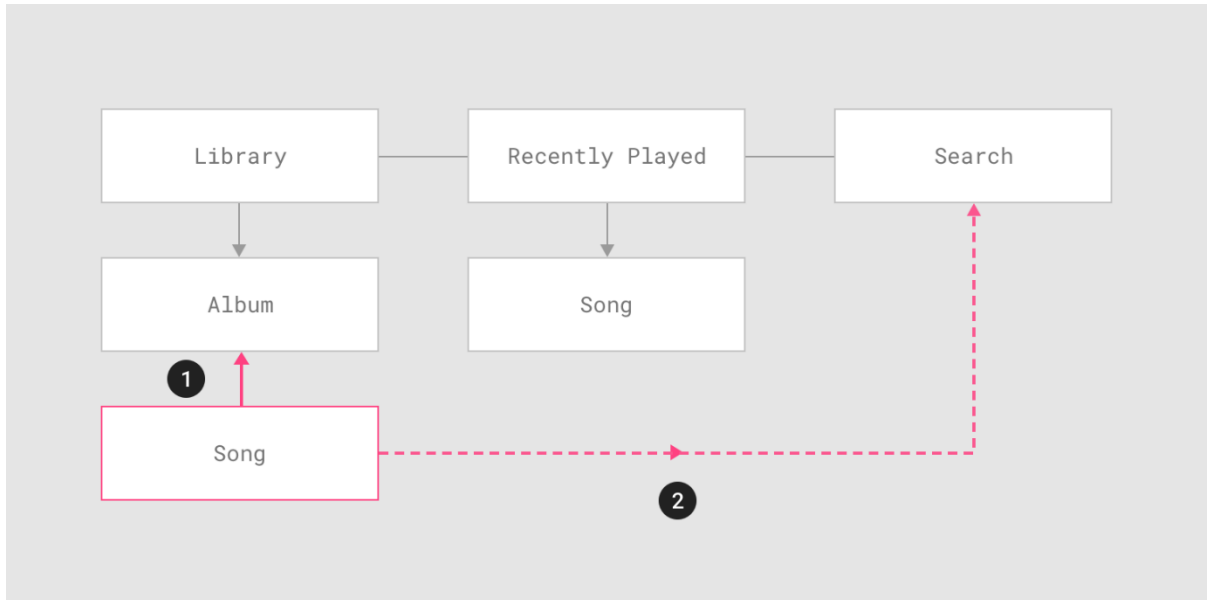

Figure 17 Reverse navigation

(Google, 2019)

### 3.3.9.2 feedback

Following suggestions are

- Feedback must be immediate;
- Too much feedback can be more annoying than too little;
- All actions need to be confirmed, but in a manner that is unobtrusive;
- Present the current state of the system for all time;
- Provide realistic responses. User should directly control the movement of elements without action delay, which could occur in when the interface is using an animation

triggered by gestures. The speed of the user's gesture should be matched by the speed of the element being moved across the screen;

- Element transitions and feedback should be continuously provided as an action progress.

#### *3.3.9.3 help & assistant & error*

- Design for situations where the intended actions/tasks may fail, or system errors may occur.
- Provide multiple shortcuts for help and assistant window throughout the UI/system if possible.
- Provide self-diagnostics and instructions for use.
- Use preview animation of suggested actions in the help dialog/assistant window to supplement explicit explanation.
- Use a standardized help icon to reduce confusion.

#### *3.3.9.4 writing*

The following suggestions focus on optimizing the reading comprehension due to the decline of cognitive ability through aging:

- Simplify the sentence structure;
- Present nontechnical terminology at a sixth-grade reading level at maximum;
- Keep content and text short and to the point;

- Complex procedures should be explicitly stated (Burdick & Kwon, 2004);

#### *3.3.9.5 visual cues*

- Give visual alternatives to sound, and vice versa. Provide closed captions, a transcript, or other visual cues to critical audio elements and sound alerts.
- Visual cues can be used to indicate the availability of gestures, such as showing the edge of a card element or use of icons that demonstrate the gesture.
- Elevated elements can be used as visual cues for independently movable/manipulatable parts/elements.

#### ***3.3.10 Onboarding***

Designers should have an in-depth understanding of user context through research. For example, some users may be eager to try the product without reading an instruction manual. Then, set onboarding goals based on the needs of user and the benefit that should be perceived by the users, and make sure to only show the onboarding screens to first-time users, not returning users. There are three onboarding methods that can be applied in to smart control devices:

##### Self-setup

- Use this type of onboarding method when there are choices that are customizable in the system for user's first-run, or there are user consent requirements for the product.
- All selection/choices need to be meaningful and short information, meaning

designers should not provide choice/selection that has no impact on user experience, such as information that would be only interesting to the product maker;

- Don't combine self-setup with user benefit, because it may create confusion and excessive information for the start.

#### QuickStart

- Use this type of onboarding method when the products allow users to quickly get started with the core system. Designers could use this type of onboarding method to increase engagement of the product;
- Provide a key action to get user started with the system and assistant/help-to-learn as optional choice;
- Do not leave users with a background image with nothing to do.

#### User benefit

- Present the top user benefits, or major changes/updates of the system;
- Avoid displaying excessive information and try to keep the onboarding short;
- Simplify text and imagery to focus on the essential benefits;
- Provide "skip" or "get started" option to enter the core system more quickly;
- Videos/animations are recommended.

### **3.4 Conclusion**

The goal of this guideline is to synthesize the principles of human-centered design and



inclusive design for elderly people with the innovation and possibility of elderly friendly smart home control devices, and this guideline provides a flexible foundation for designing various smart control devices/system that is inclusive for older users. There are three major sections composed to this chapter which are principles, environment, and components. Each individual section plays a unique role in the design process. The “principles” is an aggregate of the most fundamental principles that constitutes an inclusive and human-centered design of smart home control devices. All design decisions are originated and centered around these ten principles, so they could guide the design practice when there are conflicts between design options. The “components” is a list of critical elements of a control devices/system that would affect the usability and user experiences. Under each component, the author provides general and specific design suggestions based on all the principles that would be applied. The “environment” is where the smart home control devices would live in, including the technical environment in which the control devices would be connected with the home network and other smart appliances/sensors and the wide range of users by which the control devices are used to carry out a variety of daily activities. All three parts of the guideline would be applied on product development iteratively throughout the design process, and an example approach is presented in the next chapter to demonstrate how the guideline could be applied.

## **CHAPTER 4**

### **DESIGN APPLICATION**

#### **4.1 Project Introduction**

To demonstrate how this guideline could affect the design process and therefore improve the inclusiveness for wider age range of users, the author conducted an example of design application which covers the implementation of the guideline and effectiveness of the suggestions for the design of a conceptual product. The design approach applied in this example is based on author's personal design experience, and it is not necessarily the optimum approach for all smart home control devices because the design process may vary based on the marketing strategy and development stage of a product. For example, the process of redesigning a product would be different than designing new product species. The product author selected for this design project is a universal remote control, which is an ideal example of control device that has been commonly adopted in smart homes and it contains most of the components highlighted in the guideline.



## 4.2 Environment Analysis

### 4.2.1 smart home network

Devices that would potentially be controlled by the remote

Lighting	
Smart light bulbs	

Smart light switches	
Smart light hub	
Smart plug	
others	
<b>security and access control</b>	
Base stations	
Contact sensors	
Motion sensors	
Keypads/controller	
Touchscreen control panels	
Key fobs and tags	
Range extenders	
Security cameras	
Sensors and Alarms	
Panic buttons	
Smart lock	
others	

<b>home media system/service</b>	
Smart TV	
Speaker/sound bar/headphone	
Set-top boxes	
Streaming stick	
Media hub/portal	
Projectors	
Game consoles	
Audio/video devices	
Others	
<b>temperature and climate</b>	
Smart thermostat	
Smart vent	
Smart thermostat sensors	
Others	

<b>other smart home products</b>	
Robot vacuum	
Smart meat thermometer	
Fan	
washing machine	
refrigerator	
Window covering	
Pet care	
Smart bed	
toys	
Others	

Chart

## 4.2.2 user activity tools

### Device mapping

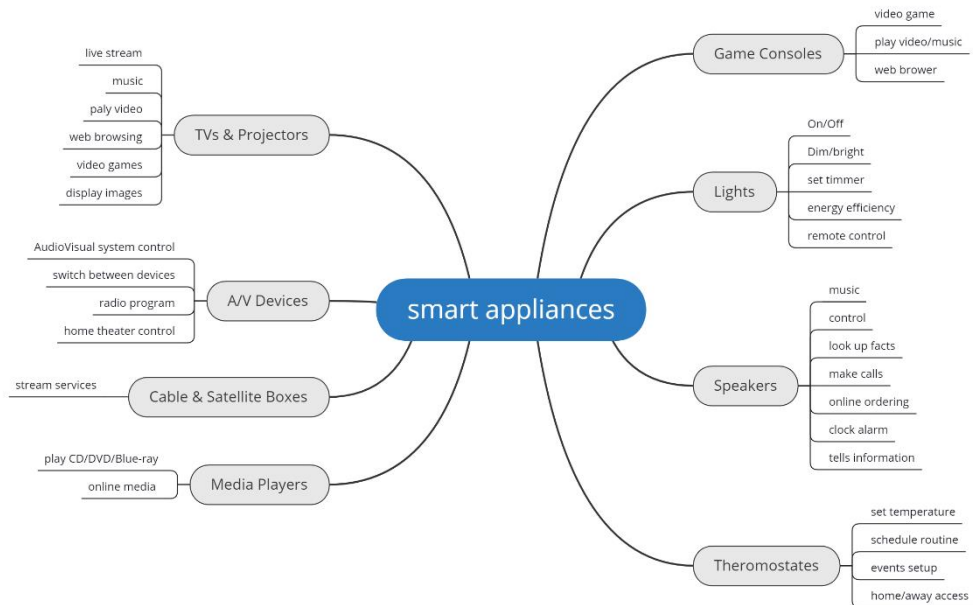

### List of activities

Determine all the activities that are available on the smart appliances that could be controlled by the remote in the home.

NO.	activity	description	frequency
1	Lighting control	Turn on/off lights, or set up lighting for specific events/scenario	2/day
2	Watch live stream	Watch live stream program on a display device	2/day
3	Listen to music	listen to music and explore new music on a speaker device	1/day
4	Listen to radio	Listen to radio program	1/day
5	Watch movie	Watch movies on a display device	2/week
6	Play video game	Play video game on a game console or a computer.	2/week
7	Adjust temperature	Adjust the temperature for specific occasion	Based on user's preference

Action analysis

<b>Activity</b>	Watch movies	<b>duration</b>	2-3 hours
<b>What do I want to accomplish?</b>			
Enjoy a scary movie			
<b>What are the alternative action sequences?</b>			
<b>Sequences</b>	<b>Actions</b>	<b>Cognition</b>	
1	Turn on TV/home theater system	Behavioral	
	Select HBO channel on cable box	Reflective	
	Dim the light to 20%	Behavioral	
	Lower temperature down 2 degrees	Behavioral	
	Watch movie alone	Visceral	
2	Lower temperature down 2 degrees	Behavioral	



	Turn on projector	Behavioral
	Turn on the google Chromecast	Reflective
	Select HBO on Chromecast	Reflective
	Gather family	Reflective
	Dim the light to 20%	Behavioral
	Watch movie with family	Visceral
3	Call friends on phone/speaker	Reflective
	Turn on TV/ home theater system	Behavioral
	Turn on Fire Stick	Reflective
	Browse through the built-in amazon app	Reflective
	Purchase a movie on Amazon	Reflective
	Dim the light to 20%	Behavioral
	Watch movie with a long-distanced friend through phone/speaker	Visceral
<b>What action can I do now?</b>		
Select the AV scene that was previously set up		
<b>How do I do it?</b>		
Select and activate it		
<b>What happened?</b>		
Show a power button		
<b>What does it mean?</b>		
The AV scene is not active until user presses the button		

<b>Is this okay? Have I accomplished my goal?</b>
(evaluate based on specific scenario)

#### *4.2.3 interface architecture*

The interface architecture of the remote control is built on top of the activity analysis and list of smart home devices. (see figure 18)

# Smart Devices

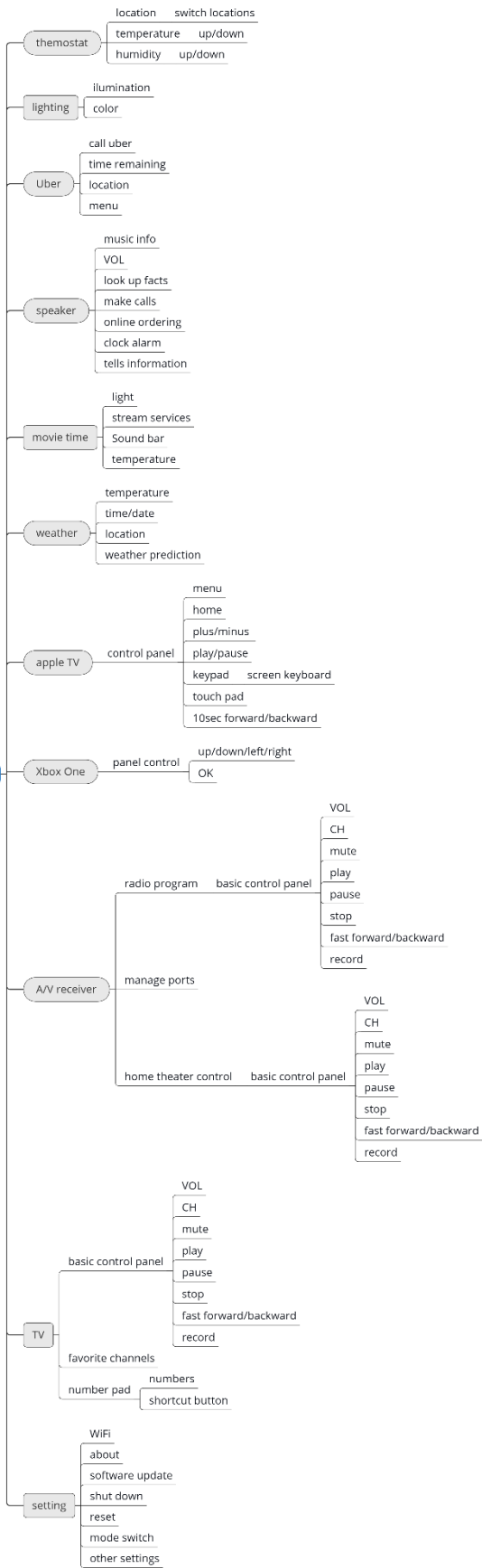

## 4.3 components identification

### 4.3.1 weight/dimension

- The curvy body form of the remote enhances the ergonomic for grip;
- The bottom of the screen and the spin wheel can be easily accessed by using only one hand;

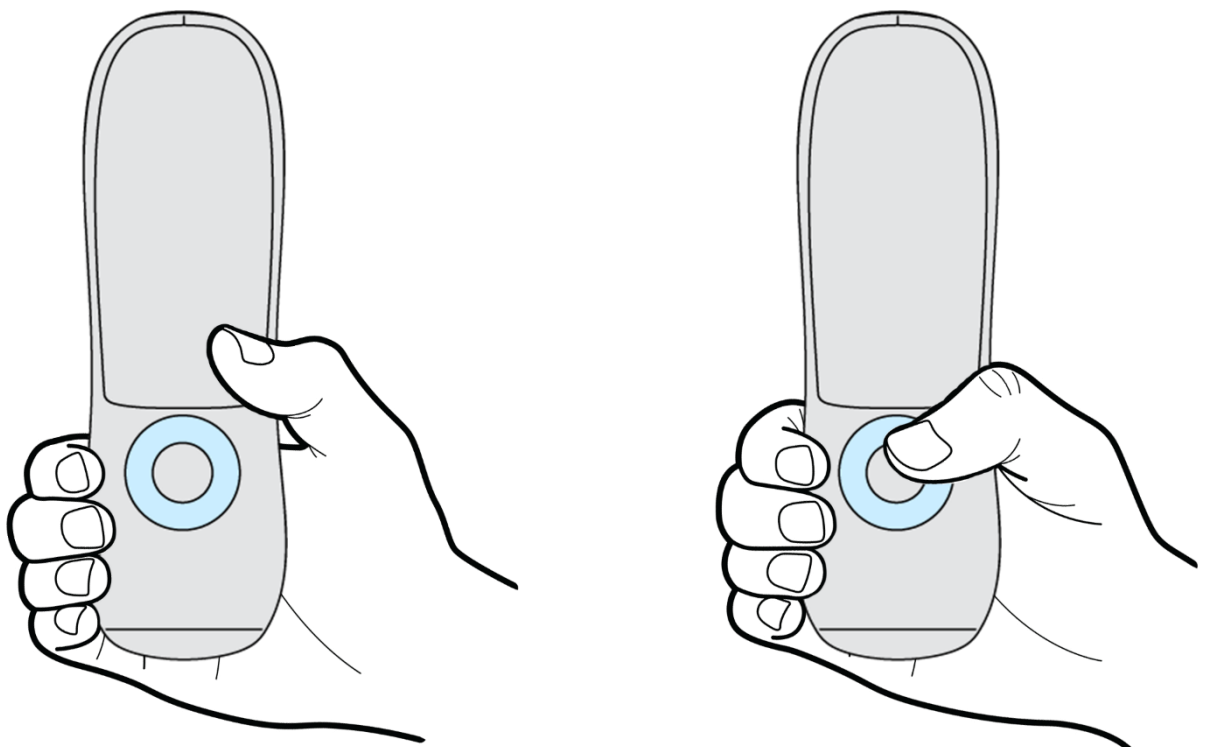

- The screen size of the remote would provide adequate display area, while the overall size of the remote remains relatively small to match the average hand size of elderly;

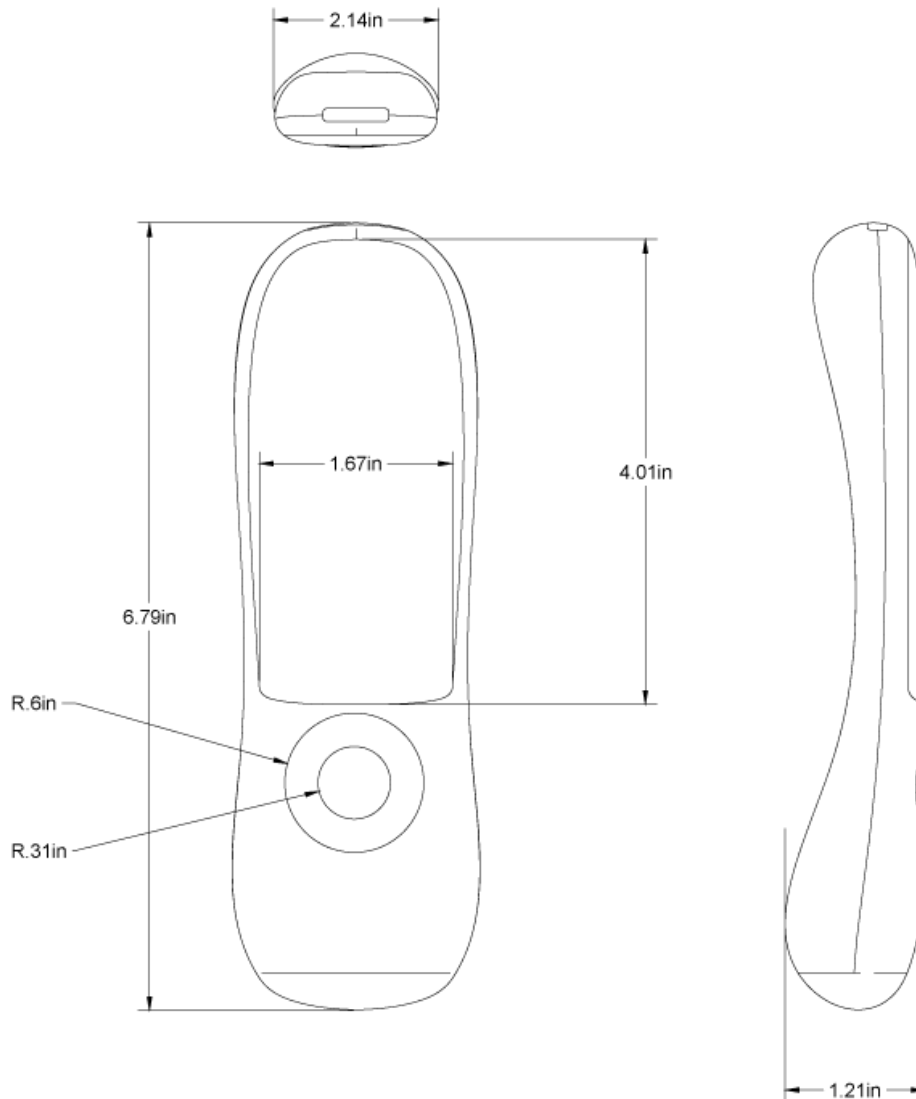

#### 4.3.2 composition

- The interface uses clearly visible elements by utilizing universal icons for general elements such as “setting” and using bold, geometric and consistent shapes for the icon;
- The interface is primarilyly black and white with little accent color, so that the

contrast would be sufficient;

- Size of the icon and control buttons are slightly larger (about 2-4dp) to make sure they are usable for older users;
- All key icons and information are placed at the top of the screen, and the home button is on the bottom where it can be pressed effortlessly by the thumb;
- Other items are placed in relative order or similar hierarchy next to each other.

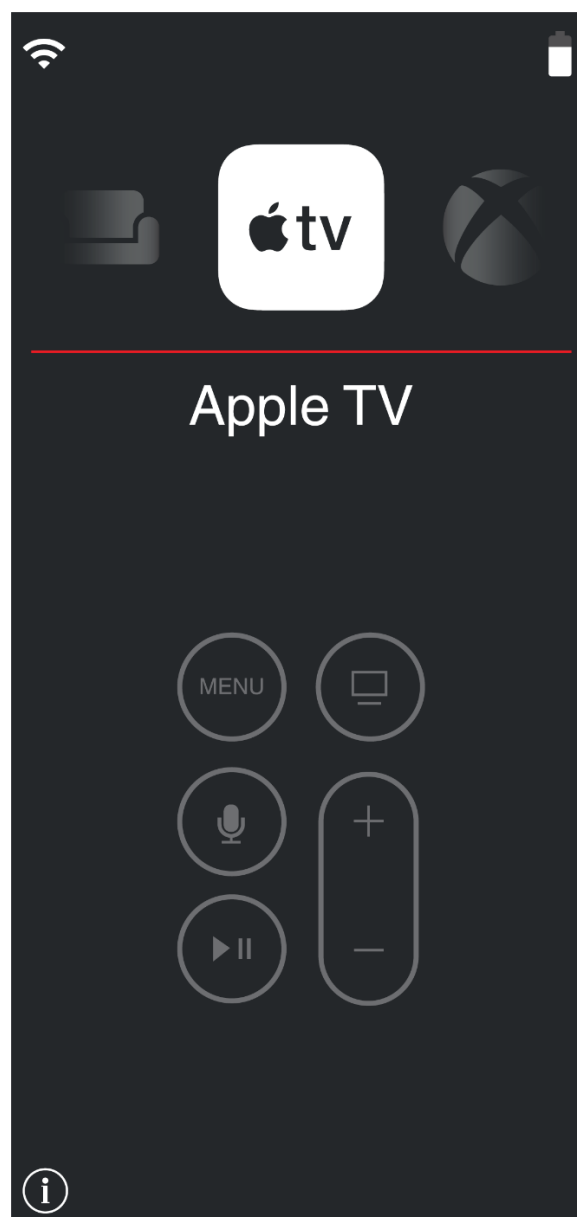

Figure 18

- To reinforce the focus, elements that are currently active are highlighted, while other inactive elements disappear.

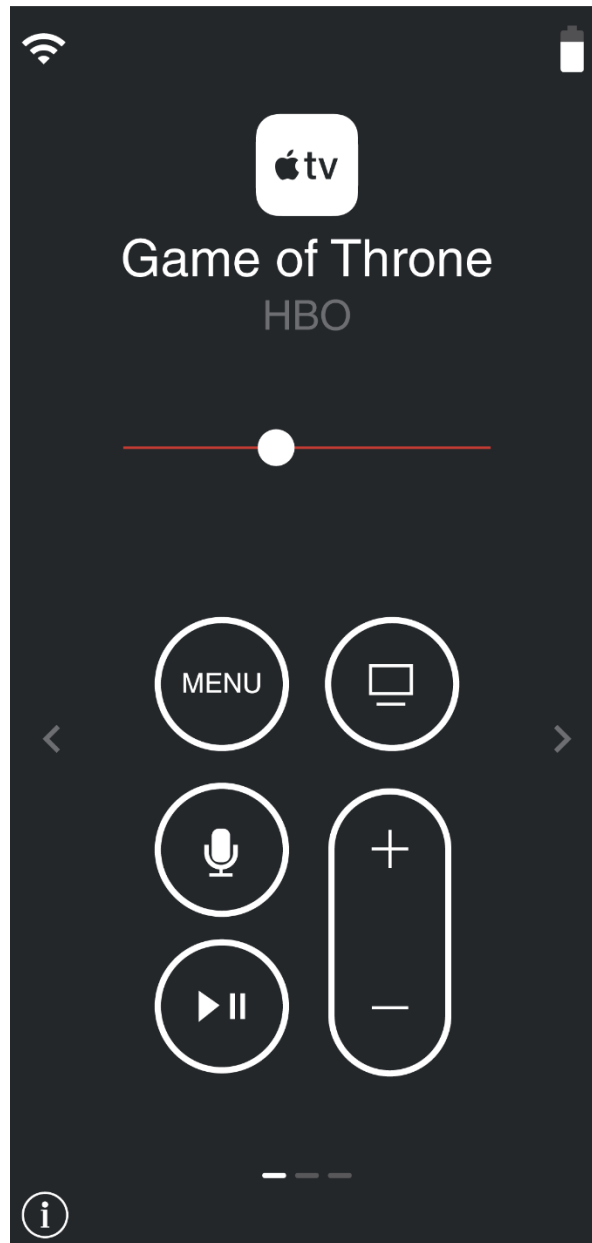

Figure 19

- The layout for each control interface is consistent;
- The order of items is arranged in the way that allows sequential operations to flow smoothly;

- Automatically switch control menu when pointing the remote to a device.

#### 4.3.3 control

- The spin wheel button clearly signifies its operation;
- The wavy surface and added texture of the spin wheel button makes it easier to spin;
- The spin wheel button is 1.2" (at least 1") in diameter, and the press button at the center is 0.625" (at least 0.3") in diameter;



Figure 20



#### *4.3.4 display*

- Remote uses a surface capacitive touch screen that is capable of displaying simple icons and information in high optical clarity and light transmission for colors;
- An illumination sensor located on the top of the screen to allow automatic illumination adjustment;
- And the illumination can be also manually adjusted in the settings.

#### *4.3.5 typography*

- The font choice for the interface is Helvetica, due to its larger x-height and wide proportions which help readability under low vision condition;
- All critical texts are white on a dark background to maximum the contrast;

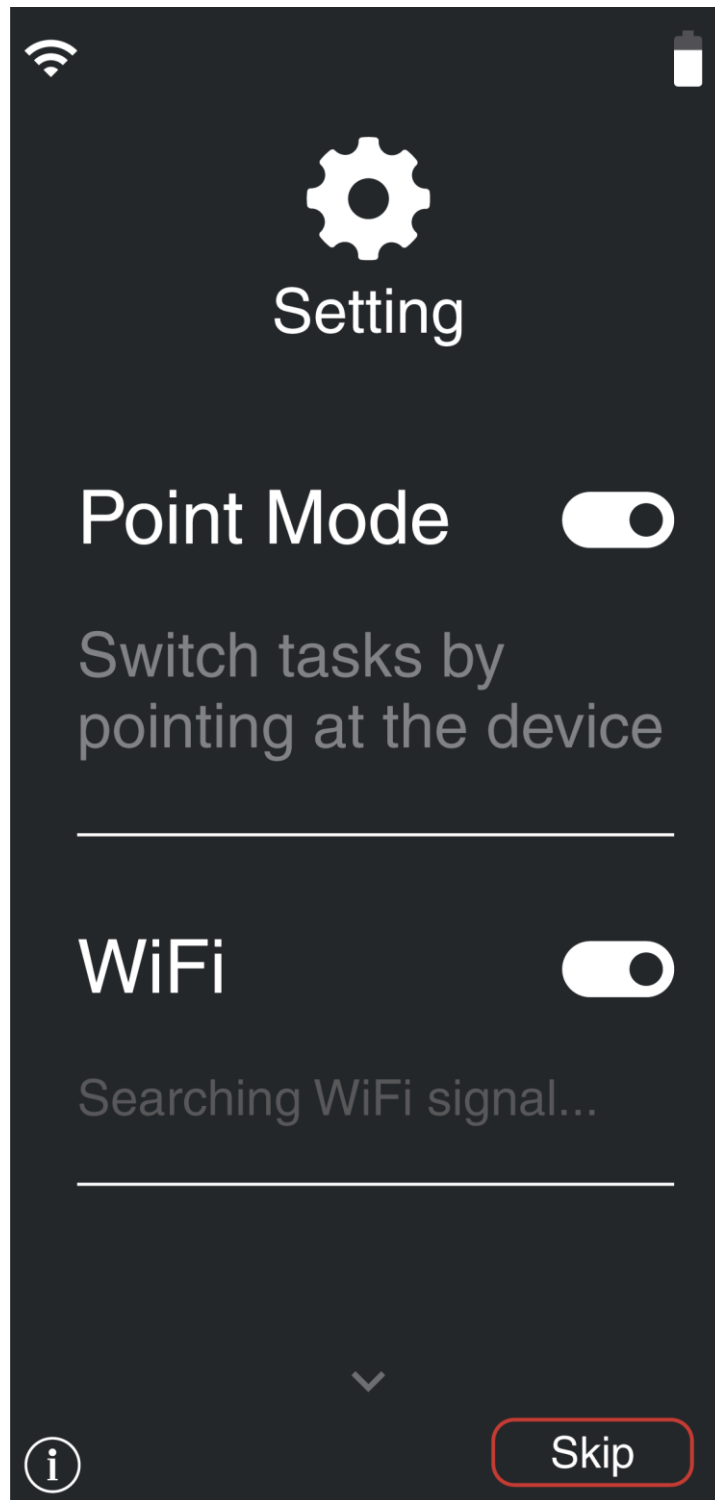

Figure 21

#### 4.3.6 iconography

- Informational icons are 34dp x 34dp, which are slightly larger than regular icons,

which are 24dp x 24dp;

- Icon buttons are 48dp x 48dp, which is the common recommended size because of the extra physical input buttons;
- All icons are simple, bold stroked, and geometric;
- All icons fit in the same grid and keyline to maintain visually consistency;
- No 3D icons

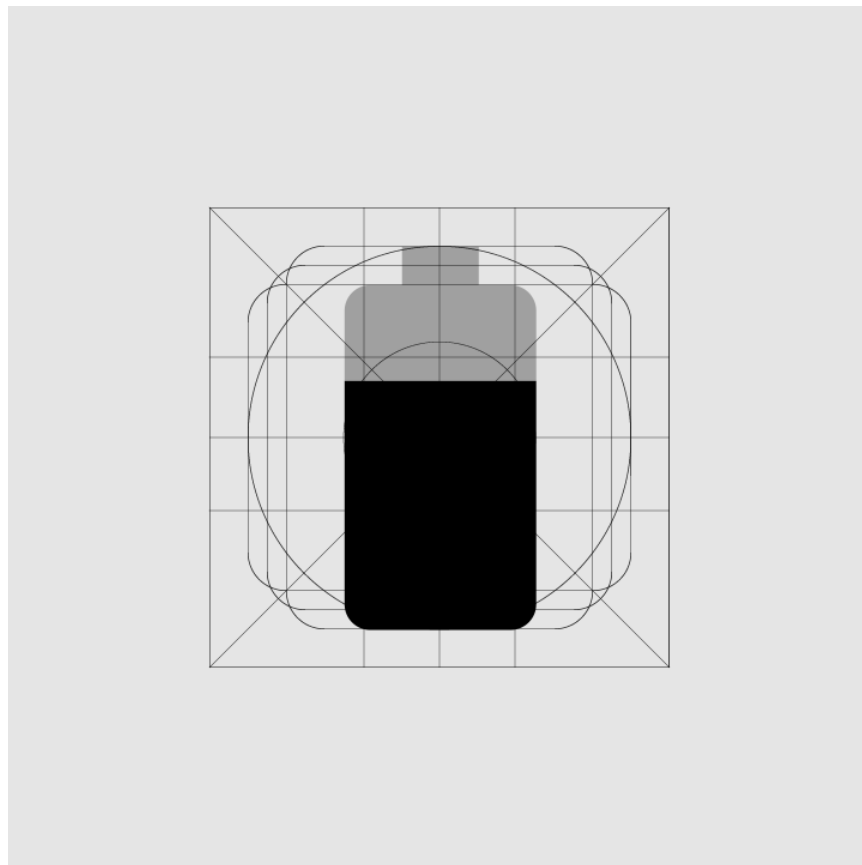

Figure 22

#### 4.3.7 color

- Red icon on the home button was purposely chosen to increase its legibility;
- All the colors used in the interface have sufficient color contrast against the

background.



Figure 23

#### *4.3.8 interaction*

- Built-in microphone and speaker for voice control and sound cues/alerts.
- Switch control target by pointing at the device;
- The built-in speaker monitors ambient noises for auto volume adjustment.

#### *4.3.9 communication*

- All three navigations can be accomplished by using either touch screen interface or physical spin wheel;
- The home button can bring the menu back to the top-level navigation at all times;

- The task icon changes from inactive to active state when the devices are turned on.

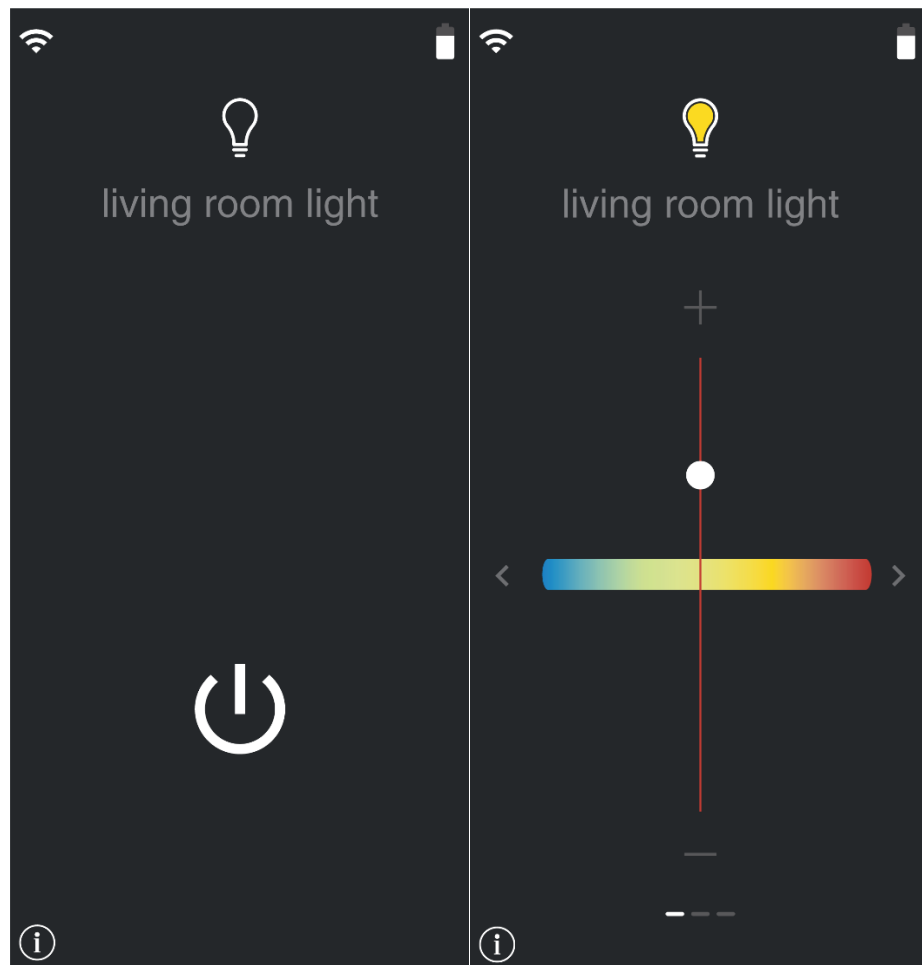

Figure 24

- The lighting color control changes color continuously as the actual light bulb acts the same way in color changing;
- Help buttons are provided throughout the whole interface;

#### 4.3.10 onboarding

- The remote uses self-setup mode for onboarding with limited information of the core benefits (top 2 selling points) embedded in the setting description;

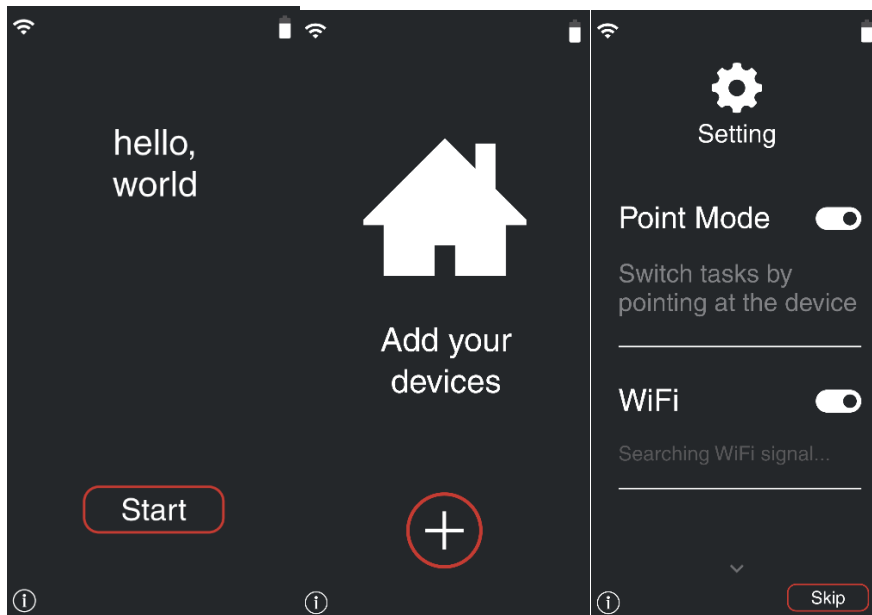

Figure 25

#### 4.4 Final delivery

*Images of the product*



Figure 26



Figure 27



Figure 28





Figure 29



Figure 30

#### **4.4 Conclusion**

The guideline is a comprehensive list of tools and components that designers can either use it as a whole package for an entire project, such as the example author provided in chapter 4 or use each component and analysis tool for a specific design goal.

Chapter 4 is an example of a design approach that integrates this guideline into a general design process to show designers how this guideline could be applied to a project as a whole package. All the components listed in section 3.3 Components do not necessarily need to be followed in the same order they are shown in this thesis. Designers can use each component independently, but all the design decisions should not contradict to any principle provided in section 3.1 Principles.

## Reference

- Alam, M. R. a. R., Mamun Bin Ibne and Mohd Ali, Mohd. (2012). A Review of Smart Homes – Past, Present, and Future. *A Review of Smart Homes – Past, Present, and Future*, 42, 1190-1203. doi:10.1109/TSMCC.2012.2189204
- Anderson, M., & Perrin, A. (2017). Technology use among seniors. *Washington, DC: Pew Research Center for Internet & Technology*.
- Andrew W. Roberts, S. U. O. (2018). The Population 65 Years and Older in the United States: 2016. Retrieved from <https://www.census.gov/content/dam/Census/library/publications/2018/acs/ACS-38.pdf>
- Bloom, D. E., & Canning, D. (2004). *Global demographic change: Dimensions and economic significance*. Retrieved from
- Burdick, D. C., & Kwon, S. (2004). *Gerotechnology: Research and practice in technology and aging*: Springer Publishing Company.
- Census., U. S. B. o. t. (2002a). *Current population survey reports: Marital status and living arrangements*. Retrieved from Washington, DC:
- Clancy, S. M., & Hoyer, W. J. J. D. P. (1994). Age and skill in visual search. *30*(4), 545.
- Craik, F. I. M., & Salthouse, T. A. (1992). *The handbook of aging and cognition*. Hillsdale, NJ, US: Lawrence Erlbaum Associates, Inc.
- Davis, F. D. J. M. q. (1989). Perceived usefulness, perceived ease of use, and user acceptance

of information technology. 319-340.

De Beni, R., Borella, E., Carretti, B. J. A., Neuropsychology, & Cognition. (2007). Reading comprehension in aging: The role of working memory and metacomprehension. *14*(2), 189-212.

Dingli, A., & Seychell, D. (2015). Smart Homes. In *The New Digital Natives: Cutting the Chord* (pp. 85-101). Berlin, Heidelberg: Springer Berlin Heidelberg.

Einstein, G. O., McDaniel, M. A. J. J. o. E. P. L., Memory, & Cognition. (1990). Normal aging and prospective memory. *16*(4), 717.

Etholm, B., & Belal Jr, A. (1974). Senile changes in the middle ear joints. *Annals of Otology, Rhinology & Laryngology*, *83*(1), 49-54.

Farber, N., Shinkle, D., Lynott, J., Fox-Grage, W., & Harrell, R. (2011). Aging in place: A state survey of livability policies and practices.

Fozard, J. R., Herman Bouma, JAM Graafmans, James. (2000). Gerontechnology: Creating enabling environments for the challenges and opportunities of aging. *Educational Gerontology*, *26*(4), 331-344.

Garrett, J. J. (2010). *Elements of user experience, the: user-centered design for the web and beyond*: Pearson Education.

Google. (2019, FEB 27, 2019). Design-Material Design. Retrieved from <https://material.io/design/>

Hancock, H. E., Fisk, A. D., & Rogers, W. A. J. E. i. D. (2001). Everyday products: Easy to use... or not? , *9*(4), 12-18.

Harper, R. (2006). *Inside the smart home*: Springer Science & Business Media.

Ison, J. R., Virag, T. M., Allen, P. D., & Hammond, G. R. (2002). The attention filter for tones in noise has the same shape and effective bandwidth in the elderly as it has in

young listeners. *The Journal of the Acoustical Society of America*, 112(1), 238-246.

James, W. (1890). *The principles of psychology*. New York: H. Holt and Company.

Jiang, L., Liu, D.-Y., & Yang, B. (2004). *Smart home research*. Paper presented at the Proceedings of 2004 International Conference on Machine Learning and Cybernetics (IEEE Cat. No. 04EX826).

Johnson, C. (1986). *Peripheral visual fields and driving in an aging population*. Paper presented at the Invitational Conference on Work, Aging, and Vision, National Research Council, Washington, DC.

Johnson Jr, J. H., & Appold, S. J. K. I. (2017). US older adults: Demographics, living arrangements, and barriers to aging in place.

Kärkkäinen, L., & Laarni, J. (2002). *Designing for small display screens*. Paper presented at the Proceedings of the second Nordic conference on Human-computer interaction.

Kashima, K., Trus, B., Unser, M., Edwards, P., & Datiles, M. (1993). Aging studies on normal lens using the Scheimpflug slit-lamp camera. *Investigative ophthalmology & visual science*, 34(1), 263-269.

Lee, R. (2003). The demographic transition: three centuries of fundamental change. *Journal of economic perspectives*, 17(4), 167-190.

Madden, D. J. (1983). Aging and distraction by highly familiar stimuli during visual search. *Developmental Psychology*, 19(4), 499.

Mahmood, A., Yamamoto, T., Lee, M., & Steggell, C. (2008). Perceptions and use of gerotechnology: Implications for aging in place. *Journal of Housing for the Elderly*, 22(1-2), 104-126.

- McDowd, J. M., & Shaw, R. J. (2000). Attention and aging: A functional perspective.
- McLellan, H. (2000). Experience design. *Cyberpsychology and behavior*, 3(1), 59-69.
- Mejdal, S., McCauley, M. E., & Beringer, D. B. (2001). Human factors design guidelines for multifunction displays. Monterey technologies inc monterey CA.
- Melenhorst, A.-S. (2002). Adopting communication technology in later life: The decisive role of benefits.
- Neale, D. C., & Carroll, J. M. (1997). The role of metaphors in user interface design. In *Handbook of human-computer interaction* (pp. 441-462): Elsevier.
- Nerlove, M. J. J. o. P. E. (1974). Household and economy: toward a new theory of population and economic growth. 82(2, Part 2), S 200-S 218.
- Newell, A. F., Gregor, P., Morgan, M., Pullin, G., & Macaulay, C. J. U. A. i. t. I. S. (2011). User-sensitive inclusive design. 10(3), 235-243.
- Nicolle, C., & Abascal, J. (2014). *Inclusive design guidelines for HCI*: CRC Press.
- Nielsen, J. (1994). *Usability engineering*: Elsevier.
- Nini, P. J. C. (2006). Typography and the aging eye: Typeface legibility for older viewers with vision problems.
- Norman, D. (2005). Human-centered design considered harmful. 12(4), 14-19.
- Norman, D. (2013). *The design of everyday things: Revised and expanded edition*: Basic books.
- Note, W. C. W. G. (2016). Contrast (Minimum): Understanding SC 1.4.3. Retrieved from <https://www.w3.org/TR/UNDERSTANDING-WCAG20/visual-audio-contrast-contrast.html>
- Number of smartphone users worldwide 2014-2020. ( 2016). Retrieved from <https://www.statista.com/statistics/330695/number-of-smartphone-users->

worldwide/

- Rizzo, A. A., Kim, G. J., Yeh, S.-C., Thiebaut, M., Hwang, J., & Buckwalter, J. G. (2005). *Development of a benchmarking scenario for testing 3D user interface devices and interaction methods*. Paper presented at the Proceedings of the 11th International Conference on Human Computer Interaction, Las Vegas, Nevada, USA.
- Rogers, E. M. (2010). *Diffusion of innovations*: Simon and Schuster.
- Rogers, W. A., Meyer, B., Walker, N., & Fisk, A. D. (1998). Functional limitations to daily living tasks in the aged: A focus group analysis. *40*(1), 111-125.
- Rowles, G. D. (1978). *Prisoners of space?: Exploring the geographical experience of older people*: Westview Press.
- Salthouse, T. A. (1992). Reasoning and spatial abilities. In *The handbook of aging and cognition*. (pp. 167-211). Hillsdale, NJ, US: Lawrence Erlbaum Associates, Inc.
- Schneider, B. A., & Pichora-Fuller, M. K. (2001). Age-related changes in temporal processing: implications for speech perception. In *Seminars in hearing* (Vol. 22, No. 03, pp. 227-240). Copyright© 2001 by Thieme Medical Publishers, Inc.
- Schultz, T. P. (1997). Demand for children in low income countries. *Handbook of population and family economics*, 1, 349-430.
- Shepard, R. N., & Metzler, J. J. S. (1971). Mental rotation of three-dimensional objects. *171*(3972), 701-703.
- Slawinski, E. B., Hartel, D. M., & Kline, D. W. (1993). Self-reported hearing problems in daily life throughout adulthood. *Psychology and aging*, *8*(4), 552.
- Statistics, F. I. F. o. A.-R. (2016). *Older Americans 2008: Key indicators of well-being*: Government Printing Office.

- Swenson, M. M. (1998). The meaning of home to five elderly women. *Health Care Women Int*, 19(5), 381-393. doi:10.1080/073993398246160
- Szajna, B. J. M. s. (1996). Empirical evaluation of the revised technology acceptance model. 42(1), 85-92.
- Tepper, L. M., & Cassidy, T. M. (2004). *Multidisciplinary perspectives on aging*. New York: Springer Pub. Co.
- Teska, R. B. (2001). The Experience Economy: Work is Theater and Every Business is a Stage. *American Planning Association. Journal of the American Planning Association*, 67(1), 125.
- Tilley, A. R. (2002a). *The Measure of Man and Woman, Revised ed.* In: John Wiley & Sons, New York, NY.
- Tilley, A. R. (2002b). *The measure of man and woman: human factors in design*: John Wiley & Sons.
- Van Den Berg, T. J. (1995). Analysis of intraocular straylight, especially in relation to age. *Optometry and Vision Science*, 72(2), 52-59.
- Van Dijk, T. A., Kintsch, W., & Van Dijk, T. A. (1983). Strategies of discourse comprehension.
- Wickens, C. D., Hollands, J. G., Banbury, S., & Parasuraman, R. (2015). *Engineering psychology & human performance*: Psychology Press.
- Williams, M. E. (2016). *The Art and Science of Aging Well: A Physician's Guide to a Healthy Body, Mind, and Spirit*: UNC Press Books.
- Winn, B., Whitaker, D., Elliott, D. B., & Phillips, N. J. (1994). Factors affecting light-adapted pupil size in normal human subjects. *Investigative ophthalmology & visual science*, 35(3), 1132-1137.
- Woodson, W. E., Tillman, B., & Tillman, P. (1992). *Human factors design handbook*:



*information and guidelines for the design of systems, facilities, equipment, and products for human use.*

Zwijssen, S. A., Niemeijer, A. R., Hertogh, C. M. J. A., & health, m. (2011). Ethics of using assistive technology in the care for community-dwelling elderly people: An overview of the literature. *15*(4), 419-427.