

WELDED WIRE SHEAR REINFORCEMENT FOR PRESTRESSED CONCRETE BRIDGE GIRDERS

by

James S. Johnston

A thesis submitted to the Graduate Faculty of
Auburn University
in partial fulfillment of the
requirements for the Degree of
Master of Science

Auburn, Alabama
December 10, 2022

Keywords: anchorage; bridges; crack control; design; development; ductility; interface
shear; shear; welded wire reinforcement

Copyright 2022 by James S. Johnston

Approved by

Robert W. Barnes, Ph.D., P.E., Chair, Associate Professor of Civil Engineering
Anton K. Schindler, Ph.D., P.E., Mountain Spirit Professor of Civil Engineering
Kadir C. Sener, Ph.D., P.E., Assistant Professor of Civil Engineering

ABSTRACT

Welded wire reinforcement (WWR) is a steel product that is prefabricated into welded sheets. While this product is seeing use as shear reinforcement in precast concrete bridge girders for some states, other states, such as Alabama, do not permit its use. The main concern is the ability of the wires to perform due to their higher yield strength and the presence of welds reducing their ductility. The perceived benefit is much faster placing times that is innate in placing sheets over single bars, leading to savings in labor.

The primary focus of this study is to assess the viability of using WWR as shear reinforcement including determining the best practices and challenges regarding its use. This was achieved by performing a literature review on the material properties of WWR, on its ability as shear reinforcement in concrete, and on the best design practices surrounding the manufacture of the product. In addition, an interview was conducted to determine the constructability of WWR, and designs of typical Alabama Department of Transportation (ALDOT) girders were performed to identify design-based limitations or benefits that caused by ALDOT specifications. Finally, a survey was performed to determine the current state of practice of WWR among state departments of transportation and to register the potential interest in WWR's use as shear reinforcement.

Overall WWR appears to be acceptable for use as shear reinforcement in prestressed concrete bridge girders. While WWR does suffer from a reduction in ductility compared to typical reinforcing bars, WWR reached shear capacities and controlled cracking as well as traditional reinforcing bars. WWR does show weakness to cyclic loading, but this fatigue weakness due to welds is considered negligible if the welds are placed outside the high stress region. The benefits of WWR appear to mainly fall in its constructability, with the product greatly reducing the number of installed stirrup elements in the fabrication bed, resulting in faster placement and inspection. The removal of stirrup hooks with its cross-wires acting as anchorage further aids this process.

ACKNOWLEDGMENTS

To my parents, who without their support and excellent food I may never have gotten this far, thank you for all that you have done. To my friends, thank you for being there on all those board game weekends. Even though we would often find ourselves never finishing, you pushed me to think harder about my choices and be a better player and person. Perhaps one day we may actually finish more games than we start. To the world's fastest Shantae speed runner, your dedication to your craft is truly inspiring. Thank you all.

I would like to also acknowledge the support of all the people who provided me with their knowledge and guidance to write this thesis. In specific, I would like to thank Dr. LaMondia for helping to craft the survey improving its design and execution, and I would like to thank those individuals that then took the time out of their day to respond to that survey and provide drawings to represent their state DOT's policy on welded wire reinforcement. Also, thanks to Dexter Ladner and Ben Spruill who gave valuable insight in how they used welded wire reinforcement at Gulf Coast Prestressed and in accommodations they wished to see. Many thanks as well to ALDOT for providing some typical girders to be compared.

I would like to thank my Committee Chair, Dr. Barnes, and the rest of my advising committee, Dr. Schindler and Dr. Sener, for their guidance without which this thesis would not have been possible. Thanks to the Auburn Highway Research Center, whose funding of this project afforded me with this Graduate Assistantship and made my graduate studies possible.

TABLE OF CONTENTS

LIST OF TABLES.....	7
LIST OF FIGURES.....	10
CHAPTER 1: INTRODUCTION.....	13
1.1 BACKGROUND	13
1.2 OBJECTIVES.....	16
1.3 SCOPE	16
1.4 ORGANIZATION OF THESIS.....	17
CHAPTER 2: LITERATURE REVIEW.....	18
2.1 INTRODUCTION.....	18
2.2 MANUFACTURING AND DESIGN METHODS.....	18
2.3 WWR MECHANICAL PROPERTIES	21
2.3.1 Yield Strength.....	21
2.3.2 Ductility.....	21
2.3.3 Fatigue Resistance	23
2.4 WWR AS SHEAR REINFORCEMENT IN CONCRETE.....	24
2.4.1 Shear Strength.....	25
2.4.2 Fatigue Strength.....	25
2.4.3 Development.....	28
2.4.4 Crack Control	31
2.5 CONCLUSIONS.....	34
2.6 AASHTO LRFD WWR PROVISIONS	34
CHAPTER 3: STATE OF PRACTICE.....	37
3.1 INTRODUCTION.....	37

3.2	SURVEY	37
3.2.1	Introduction	37
3.2.2	Results	39
3.2.3	Conclusions.....	47
CHAPTER 4: IMPLEMENTATION OF WWR SHEAR REINFORCEMENT.....		48
4.1	INTRODUCTION.....	48
4.2	Fabrication and Installation	48
4.3	Constructability Design Considerations.....	53
CHAPTER 5: DESIGN COMPARISON—WWR VERSUS BAR STIRRUPS		58
5.1	INTRODUCTION.....	58
5.2	DESIGN METHODOLOGY	58
5.3	BT-74 MODIFIED SECTION, 166 FT LONG GIRDER.....	61
5.4	AASHTO TYPE III SECTION, 89 FT LONG GIRDER.....	70
5.5	BT-72 SECTION, 134 FT LONG GIRDER	79
5.6	AASHTO TYPE I MODIFIED SECTION, 79 FT LONG GIRDER	89
5.7	CONCLUSIONS FROM DESIGN COMPARISONS.....	98
CHAPTER 6: SUMMARY, CONCLUSIONS, AND RECOMMENDATIONS.....		100
6.1	SUMMARY.....	100
6.2	OBSERVATIONS AND CONCLUSIONS	101
6.3	RECOMMENDATIONS FOR WELDED WIRE REINFORCEMENT USE	102
6.4	RECOMMENDATIONS FOR FUTURE RESEARCH	102
References.....		104
APPENDIX A: STATE DRAWINGS.....		107
APPENDIX B: CALCULATIONS		116
MODIFIED BT BEAM		116

AASHTO TYPE III.....	121
BT-72.....	127
Modified AASHTO Type I	133

LIST OF TABLES

Table 2-1 Welded Wire Reinforcement Minimum Strength Requirements (ASTM 2018)	21
Table 2-2 Reinforcement types present in Figure 2-7 (Xuanl et al. 1988)	32
Table 2-3 Summarized AASHTO LRFD WWR Provisions (2020)	35
Table 3-1 Benefits cited by respondents in survey	43
Table 3-2 Challenges cited by respondents in survey	44
Table 3-3 Good practices cited by respondents in survey	44
Table 5-1 Designation of design variations	59
Table 5-2 Example Standardized Sheet Details	60
Table 5-3 Shear design requirements for modified BT-74 girder	64
Table 5-4 Modified BT-74 stirrup gross quantities for ALDOT design variations	69
Table 5-5 Modified BT-74 stirrup sheet gross quantities for AASHTO design variations	70
Table 5-6 Shear design requirements for AASHTO Type III girder	74
Table 5-7 AASHTO Type III section stirrup gross quantities for ALDOT design variations	79
Table 5-8 AASHTO Type III section stirrup gross quantities for AASHTO design variations	79
Table 5-9 Shear design requirements for BT-72 girder	83
Table 5-10 BT-72 section stirrup gross quantities for ALDOT design variations	88
Table 5-11 BT-72 section stirrup gross quantities for AASHTO design variations	88
Table 5-12 Shear design requirements for modified AASHTO Type I beam	92
Table 5-13 AASHTO Type I modified section stirrup gross quantities for ALDOT design variations	97
Table 5-14 AASHTO Type I modified section stirrup gross quantities for AASHTO design variations	97
Table B-1 Geometric and basic material properties of the modified BT girder	116
Table B-2 Determining shear angle and beta of the modified BT girder	117

Table B-3 Required stirrups for shear strength at 60 ksi design yield strength for the modified BT girder	118
Table B-4 Required stirrups for shear strength at 75 ksi design yield strength for the modified BT girder	119
Table B-5 Reinforcement required to meet anchorage zone splitting resistance for the modified BT girder	119
Table B-6 Required interface shear reinforcement for the modified BT girder	120
Table B-7 Geometric and basic material properties of the AASHTO Type III girder....	121
Table B-8 Finding the depth of the effective compression block for the AASHTO Type III girder	121
Table B-9 Determining shear angle and beta of the AASHTO Type III girder	123
Table B-10 Required stirrups for shear strength at 60 ksi design yield strength for the AASHTO Type III girder	124
Table B-11 Required stirrups for shear strength at 75 ksi design yield strength for the AASHTO Type III girder	125
Table B-12 Reinforcement required to meet anchorage zone splitting resistance for the AASHTO Type III girder	125
Table B-13 Required interface shear reinforcement for the AASHTO Type III girder..	126
Table B-14 Geometric and basic material properties of the BT-72 girder.....	127
Table B-15 Finding the depth of the effective compression block for the BT-72 girder	127
Table B-16 Determining shear angle and beta of the BT-72 girder	129
Table B-17 Required stirrups for shear strength at 60 ksi design yield strength for the BT-72 girder	130
Table B-18 Required stirrups for shear strength at 75 ksi design yield strength for the BT-72 girder	131
Table B-19 Reinforcement required to meet anchorage zone splitting resistance for the BT-72 girder	131
Table B-20 Required interface shear reinforcement for the BT-72 girder.....	132
Table B-21 Geometric and basic material properties of the Modified AASHTO Type I	133
Table B-22 Determining shear angle and beta of the Modified AASHTO Type I.....	134

Table B-23 Required stirrups for shear strength at 60 ksi design yield strength for the Modified AASHTO Type I	135
Table B-24 Required stirrups for shear strength at 60 ksi design yield strength for the Modified AASHTO Type I	136
Table B-25 Reinforcement required to meet anchorage zone splitting resistance for the Modified AASHTO Type I	136
Table B-26 Required interface shear reinforcement for the Modified AASHTO Type I	137

LIST OF FIGURES

Figure 1-1 Example Welded Wire Reinforcement sheet.....	14
Figure 1-2 WWR reinforcement installed in prestressed girder prior to concrete placement.....	15
Figure 2-1 Welded Wire Reinforcement designation (Wire Reinforcement Institute 2016)	18
Figure 2-2 Welded Wire Reinforcement Layout (Wire Reinforcement Institute 2021) ...	19
Figure 2-3 Stress strain curve of conventional reinforcement and WWR with and without a cross-weld (Yount et al. 2021).....	23
Figure 2-4 Cyclic loading scheme for Series A in Pincheira et al. (1989).....	27
Figure 2-5 Load-deflection curve for Series A, where the applied shear is normalized to the expected shear reinforcement capacity (adapted from Pincheira et al. 1989).....	28
Figure 2-6 Development of WWR as a single leg [C5.10.8.2.6c-1] (AASHTO 2020)	29
Figure 2-7 Development of plain WWR stirrups (American Concrete Institute Committee 318 2019)	29
Figure 2-8 Fracture of transverse and longitudinal wire (Pincheira et al. 1989)	30
Figure 2-9 Typical shear crack patterns of beams (Xuanl et al. 1988)	31
Figure 2-10 Maximum crack width vs total load (Mansur et al. 1987).....	32
Figure 2-11 Maximum crack width against number of loading cycles.....	33
Figure 3-1 State respondents to WWR survey highlighted in green.....	37
Figure 3-2 For survey respondents only, state allowance of WWR as shear reinforcement in prestressed concrete bridge girders	39
Figure 3-3 Including nonresponding states, state allowance of WWR as shear reinforcement in prestressed concrete bridge girders	40
Figure 3-4 State shear reinforcement preference between WWR or reinforcing bars ...	41
Figure 3-5 Highest allowed design yield strength for WWR shear reinforcement.....	42
Figure 3-6 States with standard design drawings that incorporate WWR.....	43
Figure 3-7 State allowance of WWR as confinement of the bottom flange in the prestress transfer zone.....	45

Figure 3-8 State allowance of WWR as supplemental web reinforcement in prestressed anchorage/transfer zones.....	46
Figure 3-9 State allowance of WWR as interface-shear reinforcement between concrete girder and deck	46
Figure 3-10 State allowance for WWR as shear reinforcement in nonprestressed bridge components.....	47
Figure 4-1 Typical WWR U-stirrup sheet prior to bending.....	49
Figure 4-2 Stack of WWR U-stirrup sheets after bending.....	49
Figure 4-3 WWR stirrups placed in girder.	50
Figure 4-4 Example WWR U-stirrup cross section showing AASHTO (2020) requirements for placement of cross-wires.....	51
Figure 4-5 Time savings from using WWR on bending and placement.....	52
Figure 4-6 Standardized stirrup spacings and lengths for Texas I-girders (Texas Department of Transportation 2019)	55
Figure 4-7 Typical reinforcing bar stirrup configuration.	57
Figure 5-1 End cross section of BT-74 modified section	62
Figure 5-2 BT-74 modified cross section at the hold down points	63
Figure 5-3 Modified BT-74 potential stirrup spacing configurations that meet ALDOT spacing requirements	66
Figure 5-4 Modified BT-74 potential stirrup spacing configurations that meet AASHTO requirements	67
Figure 5-5 Reinforcing bars tied to WWR stirrup sheet to achieve a larger equivalent stirrup size	68
Figure 5-6 End cross section of AASHTO Type III girder.....	72
Figure 5-7 Hold down point cross section of AASHTO Type III girder.....	73
Figure 5-8 AASHTO Type III girder potential stirrup spacing configurations that meet ALDOT spacing requirements	76
Figure 5-9 AASHTO Type III girder potential stirrup spacing configurations that meet AASHTO requirements.....	77
Figure 5-10 End cross section of BT-72 girder.....	81
Figure 5-11 Hold down point cross section of BT-72 girder.....	82

Figure 5-12 BT-72 girder potential stirrup spacing configurations that meet ALDOT spacing requirements	85
Figure 5-13 BT-72 girder potential stirrup spacing configurations that meet AASHTO requirements	86
Figure 5-14 End cross section of modified AASHTO Type I girder	90
Figure 5-15 Cross section at the hold down point of the modified AASHTO Type I girder	91
Figure 5-16 Modified AASHTO Type I girder potential stirrup spacing configurations that meet ALDOT spacing requirements	94
Figure 5-17 Modified AASHTO Type I girder potential stirrup spacing configurations that meet AASHTO requirements.....	95
Figure A-1 Colorado stirrup details showing WWR use as shear reinforcement but not as interface shear reinforcement (Colorado Department of Transportation 2020)	107
Figure A-2 Colorado standard stirrup spacings (Colorado Department of Transportation 2020).....	108
Figure A-3 Florida I-61 beam alternate details for using WWR (Pieces K) D31 at ends D25 elsewhere (Florida Department of Transportation 2022)	109
Figure A-4 Illinois standard WWR stirrups and spacings IL90 beam (State of Illinois Department of Transportation 2021)	110
Figure A-5 Louisiana LG25 WWR Stirrups (Louisiana Department of Transportation and Development 2018).....	111
Figure A-6 Missouri PSI-06-NU-WWR stirrup design (Missouri Highways and Transportation Commission 2021)	111
Figure A-7 Nebraska WWR Stirrups as found in PCI Design Manual (Precast/Prestressed Concrete Institute 2014).....	112
Figure A-8 Ohio AASHTO type 4 girder has WWR as shear reinforcement. (State of Ohio Department of Transportation 2021).....	113
Figure A-9 Pennsylvania bulb-tee girder WWR as shear reinforcement (Commonwealth of Pennsylvania 2013).....	114
Figure A-10 Texas optional WWR substitution and bottom detail (Texas Department of Transportation 2019).....	115

CHAPTER 1: INTRODUCTION

1.1 BACKGROUND

Welded wire reinforcement (WWR) is a product where cold-rolled wires are welded into prefabricated sheets as shown in Figure 1-1. WWR can be fabricated from both smooth and deformed wires and is produced in a higher grade than typical reinforcing steel due to the cold-rolling process. This greater strength may invite reductions in material thus reducing reinforcement congestion. While WWR has a greater fabrication cost compared to typical steel reinforcing bars, a sheet of reinforcement prefabricated to match a specified spacing is faster to install than a corresponding amount of individual reinforcing bars, which results in labor savings and efficient use of plant resources. This potential labor savings makes WWR most effective in reinforcing layouts where a specified reinforcement size at a specified spacing is repeated at large scale.

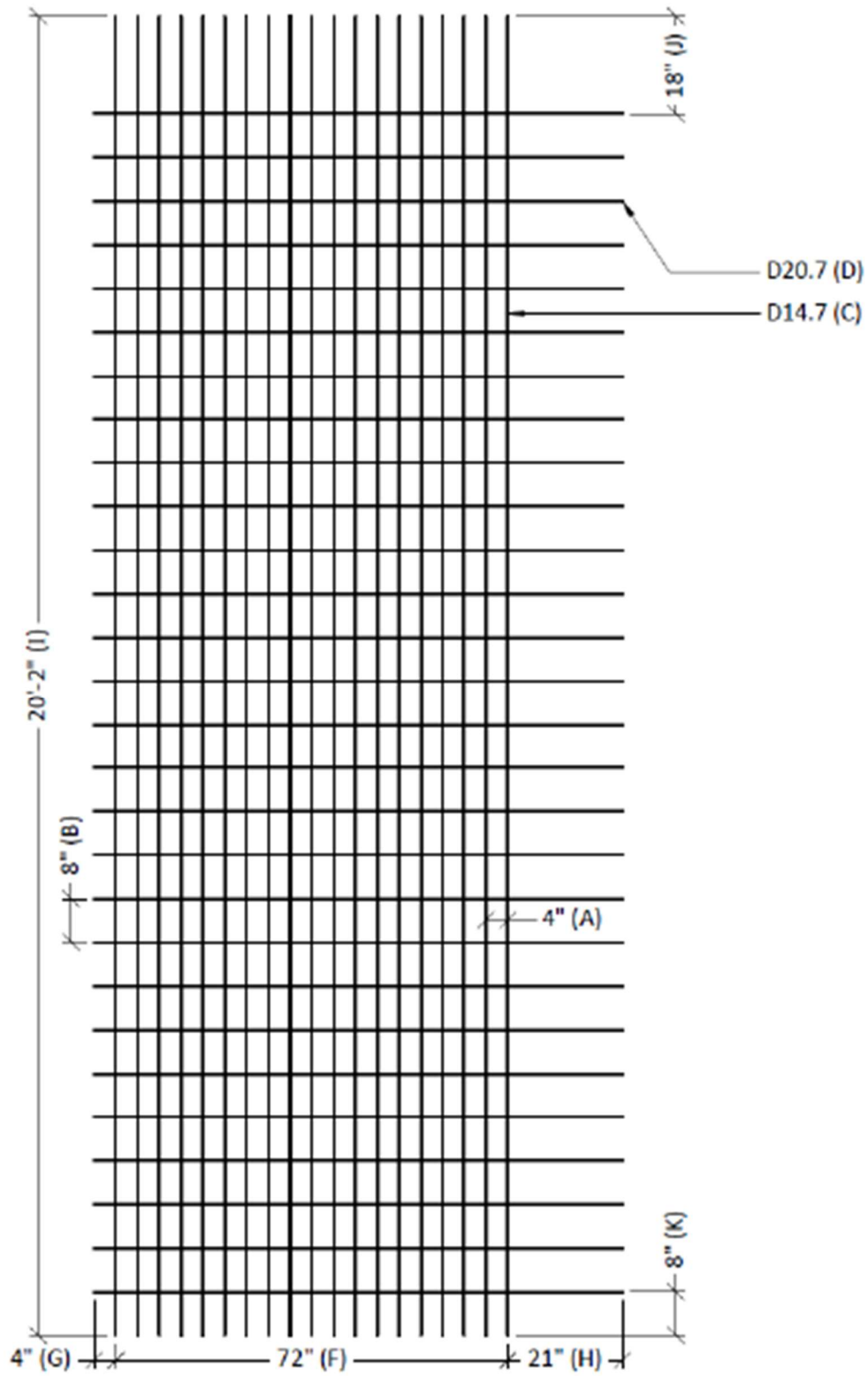

Figure 1-1 Example Welded Wire Reinforcement sheet
(Wire Reinforcement Institute 2021)

One such repetitive reinforcement layout is shear reinforcement in precast, prestressed concrete bridge girders as seen in Figure 1-2. These prestressed concrete girders are the most common type of moderate-span bridge system in Alabama and many other states. While neighboring state transportation agencies permit the use of WWR for shear reinforcement, the Alabama Department of Transportation (ALDOT) only permits WWR to be used as confining reinforcement in these girders. The concern is the presence of welds in WWR that are not present in typical reinforcing steel. These welds are sensitive to fatigue stresses and reduce the overall ductility of the wires. Understanding the advantages and potential weaknesses of WWR use could lead to significant cost savings for prestressed concrete bridge girders and other reinforced concrete structures.



Figure 1-2 WWR reinforcement installed in prestressed girder prior to concrete placement

1.2 OBJECTIVES

The objective of this research described in this thesis is to clear the path to more cost-efficient concrete bridges by identifying the specific benefits and impediments associated with using WWR as shear reinforcement in ALDOT prestressed concrete girders. The insight gained might also clear a path to more cost-effective concrete bridges of all types as the knowledge is applicable beyond prestressed concrete girders. The viability of using WWR as shear reinforcement from the perspective of material behavior, constructability, and design is evaluated in this thesis. Tasks associated with achieving the primary objective include

- Provide relevant design specifications and research findings relating to WWR and its use as shear reinforcement;
- Identify the current state of practice of WWR use as shear reinforcement among state DOTs;
- Identify the benefits and obstacles relating to the constructability of WWR as shear reinforcement; and
- Identify the benefits and challenges of designing WWR as shear reinforcement in accordance with ALDOT and AASHTO design provisions.

1.3 SCOPE

The scope of this project was limited to WWR as shear reinforcement in prestressed bridge girders. A survey to establish current practices and attitudes of WWR as shear reinforcement among state DOTs was performed. A comparative design was performed of four representative ALDOT girders in accordance with variable design requirements from meeting all ALDOT design specifications to only satisfy AASHTO design specifications. In addition, constructability aspects were discussed with personnel at a prestressed girder plant.

Beyond the scope of this thesis—but of importance—is the performance of WWR in roles other than shear reinforcement such as confining and supplemental reinforcement or its effectiveness in nonprestressed components.

1.4 ORGANIZATION OF THESIS

Chapter 2 outlines the manufactural and mechanical properties of WWR that make it unique relative to typical reinforcing bars. The chapter also includes information on the behavior of WWR as shear reinforcement when placed in concrete. WWR's properties and its behavior are key to understanding how to design with WWR and the unique provisions in AASHTO LRFD that apply to WWR.

Chapter 3 provides an overview of the current state of practice of providing WWR as shear reinforcement for prestressed bridge girders. The focus is on how different state DOTs specify the use of WWR, if it is allowed, and what benefits and challenges they have experienced in its use. General interest in states that do not allow WWR's use is also gaged.

Chapter 4 describes the constructability of WWR as shear reinforcement. As part of this assessment, different girder and stirrup shapes are discussed with respect to their impact on the constructability.

Chapter 5 outlines a comparative study of the shear design of four ALDOT girders with WWR stirrups in mind. The design of each girder was performed with eight variations of specification with the most stringent being full ALDOT conformance and the least stringent being AASHTO LRFD conformance with no other requirements. Each of these designs were compared with each other and a stirrup layout provided by ALDOT.

Chapter 6 provides a final discussion of WWR as shear reinforcement. Expected benefits and obstacles are detailed. Finally, recommendations for future research are provided.

CHAPTER 2: LITERATURE REVIEW

2.1 INTRODUCTION

This chapter covers previous research performed related to welded wire reinforcement (WWR). WWR mechanical properties, relevant information about WWR manufacturing and design methods, WWR performance as shear reinforcement in concrete, and AASHTO LRFD design provisions that apply special requirements to WWR were all investigated and synthesized in this chapter.

2.2 MANUFACTURING AND DESIGN METHODS

WWR is a cold-formed steel wire product electro-welded in prefabricated grids. WWR is used as confinement steel for prestressing strands and is used in bulb-tee and I-beam girders to resist bursting stresses in the flanges after prestressing application and as web shear reinforcement (ACI 439.5R-18). An example designation for WWR is shown in Figure 2-1.

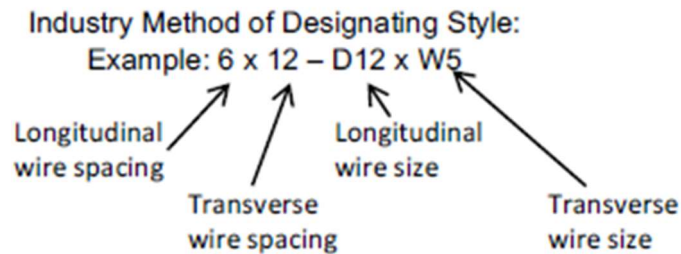

Figure 2-1 Welded Wire Reinforcement designation (Wire Reinforcement Institute 2016)

The designation is “longitudinal spacing” x “transverse spacing” – “W” for smooth or “D” for deformed, then cross-sectional nominal area per hundredth of a square inch for longitudinal wire x “W” or “D”, then cross-sectional nominal area per hundredth of a square inch for transverse wire. If the designation employs SI units, then the prefix “M” (for metric) is added to the “W” or “D” used (Wire Reinforcement Institute 2016).

The longitudinal and transverse wires are designated as oriented during manufacture and are not always representative of placement in the concrete element. These dimensions are displayed on Figure 2-2 (Wire Reinforcement Institute 2021). In

addition to this designation, the width, length, and overhangs are specified. The width is the center-to-center distance between outside longitudinal wires not including any overhangs. The length is the tip-to-tip distance of the longitudinal wires. End overhangs are the extension of longitudinal wires past the centerline of the end transverse wire. These overhangs are typically half a transverse spacing on both sides. Side overhangs are the extension of transverse wires past the centerline of the edge longitudinal wire.

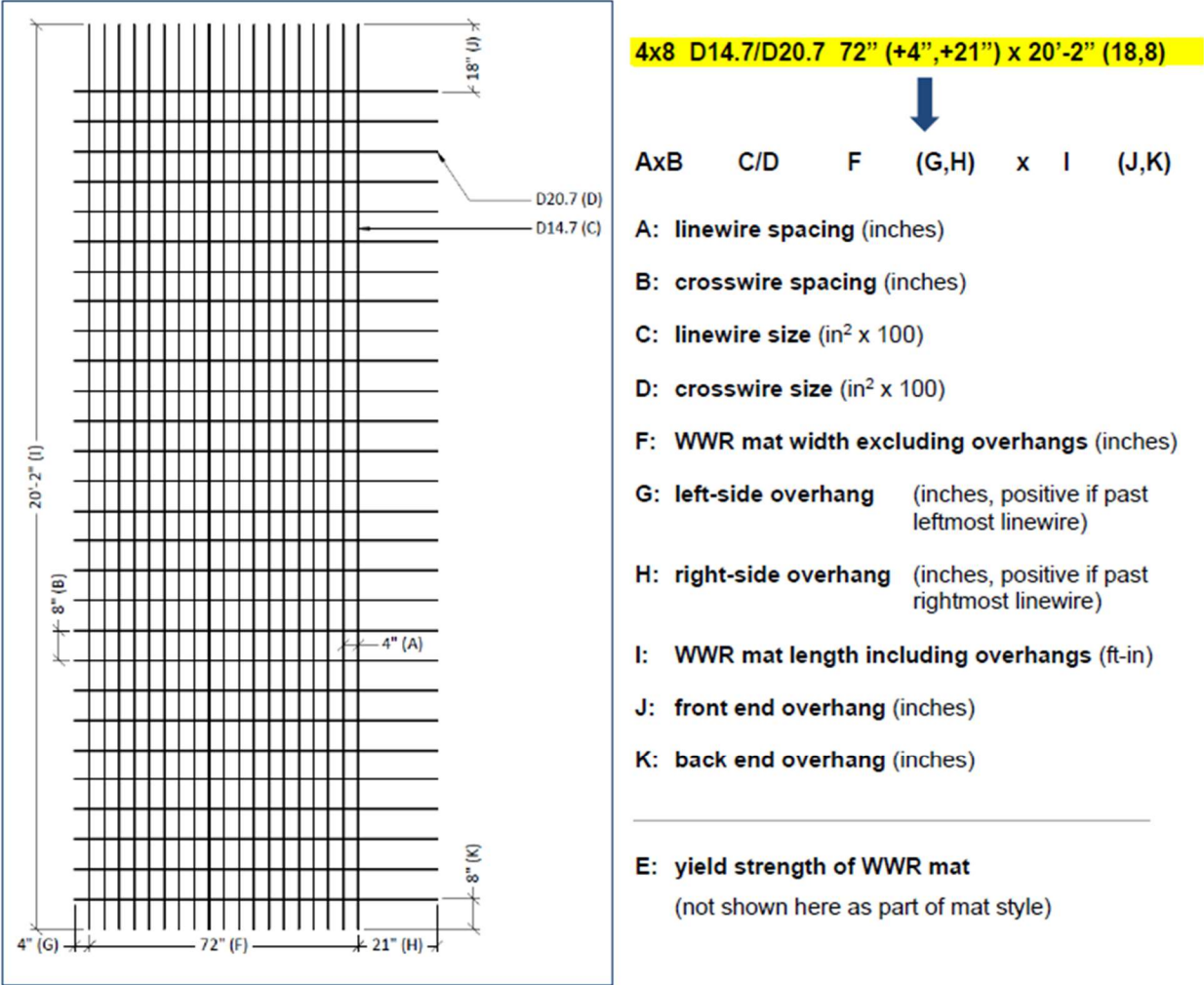

Figure 2-2 Welded Wire Reinforcement Layout (Wire Reinforcement Institute 2021)

When designing with WWR, the use of standard sheet sizes is preferred. Knowledge of critical manufacturing variables is important to minimize costs, should customization be required or if it is being investigated. Customization should be done by

prioritizing the following variables in order from the least costly change to the most: length, transverse wire spacing, transverse wire size, overhangs, width, longitudinal wire size, and longitudinal wire spacing (Wire Reinforcement Institute 2016). ASTM A1064 provides design limitations to sheet dimensions for carbon-steel WWR (American Society for Testing and Materials 2018). It is important to note that many manufacturers require minimum quantities when ordering. This makes WWR most practical for highly repetitive reinforcement layouts.

It is not expected that the engineer of record (EOR) will specify all the dimensions of WWR sheets. Instead, dimensions of structural importance are expected such as wire size, spacing, and curtailment. Sheet width, length, and overhangs are typically determined by a WWR detailer using the EOR's specifications. The detailer can create a sheet that matches the EOR's and manufacturer's requirements. While the EOR can explicitly specify all sheet details, doing so without being intimately familiar with the manufacturer's capabilities and capacities will likely cause issues in procurement (Wire Reinforcement Institute 2021).

Since the EOR is only required to specify dimensions that are also typically associated with standard reinforcing bars, WWR can be allowed through substitution. This method lets the EOR design solely in terms of reinforcing bars and then the contractor can substitute the bars with WWR with any defined limitations and circumstances. Substitution allows the contractor and WWR detailer, who know the manufacturer's capabilities and capacities, to use WWR where it is most cost-effective. While the WWR detailer obtains more flexibility with designing the WWR sheets compared to direct specification, they are constrained by a design not originally intended for WWR use (Wire Reinforcement Institute 2021).

Another design method is the use of standard sheets. This method allows an EOR to design with WWR without worrying about manufacturing impracticality. While standard sheets remove some of the design flexibility of WWR, they enable the EOR to create designs that fully utilize WWR. To use this method to its full benefit, EORs need to learn the good practices of WWR design that may not be self-evident from a reinforcing bar design approach (Wire Reinforcement Institute 2021).

2.3 WWR MECHANICAL PROPERTIES

This section focuses on WWR's mechanical properties outside of concrete. WWR's stress-strain behavior and its resistance to fatigue stresses outside concrete is strongly correlated to its performance as reinforcement in concrete.

2.3.1 Yield Strength

American Society for Testing and Materials (ASTM) A1064 provides the tensile and yield strength requirements for wires for use in WWR at different grades. The required strengths for the lowest acceptable grades of wire are displayed in Table 2-1. Smooth and deformed wire grades reach up to Grade 80 (ASTM 2018).

Table 2-1 Welded Wire Reinforcement Minimum Strength Requirements (ASTM 2018)

WIRE SIZE	TENSILE STRENGTH (PSI)	YIELD STRENGTH (PSI)	WELD SHEAR STRENGTH (PSI)
W1.2 & GREATER	75,000	65,000	35,000
LESS THAN W1.2	70,000	56,000	-
D4 THROUGH D45	80,000	70,000	35,000
LESS THAN D4	80,000	70,000	-

The American Association of Highway and Transportation Officials (AASHTO) LRFD Bridge Design Specification allows the use of a design yield strength up to 100 ksi for transverse reinforcement subjected to flexural shear without torsion and in seismic zone 1. For all other circumstances, for transverse reinforcement, the design yield strength shall be the specified yield strength where the latter does not exceed 60 ksi. If the yield strength is above 60 ksi, then the design yield strength shall be the stress corresponding to a strain of 0.0035, but not to exceed 75 ksi. This provision allows designers to take full advantage of WWR's high yield strength except for members subject to torsion or significant seismic stresses (AASHTO 2020). This increase in yield strength above typical reinforcing bars creates the potential to use less steel for the same overall capacity.

2.3.2 Ductility

The AASHTO LRFD Bridge Design Specification requires that WWR used as shear reinforcement must have its transverse wires be certified to undergo a minimum

elongation of four percent. This elongation must be measured over a gage length of at least four inches, and the gage length must include at least one crosswire. The commentary notes that WWR that has not been stress-relieved and fabricated from small wires may fail before the required strain is reached. These failures can occur at or between crosswire intersections (AASHTO 2020).

The gage length is specified so that testing of the elongation or strain of WWR is reliable. Carrillo, Rico, and Alcocer (2016) found the coefficient of variation for elongation after fracture of tested WWR used in Mexico to range from 42.8 to 75.5 percent. It was determined that the WWR tested was too brittle for use but was used regardless, likely due to improper testing procedures.

The increase in yield stress that WWR exhibits due to cold forming relative to typical reinforcing steel comes at the cost of significantly reducing the ultimate strain of WWR. Figure 2-3 illustrates the difference between WWR and typical reinforcement in terms of stress and strain. Also seen in Figure 2-3 is how cross-welds further reduce the ultimate strain of WWR by approximately 10 percent in open-air tension tests. This reduction in ultimate strain is concerning because when concrete cracks, there is a dynamic load transfer to the shear reinforcement that quickly generates large strains in the reinforcement. The inability to strain as much as required at that time may cause a sudden brittle fracture (Yount et al. 2021).

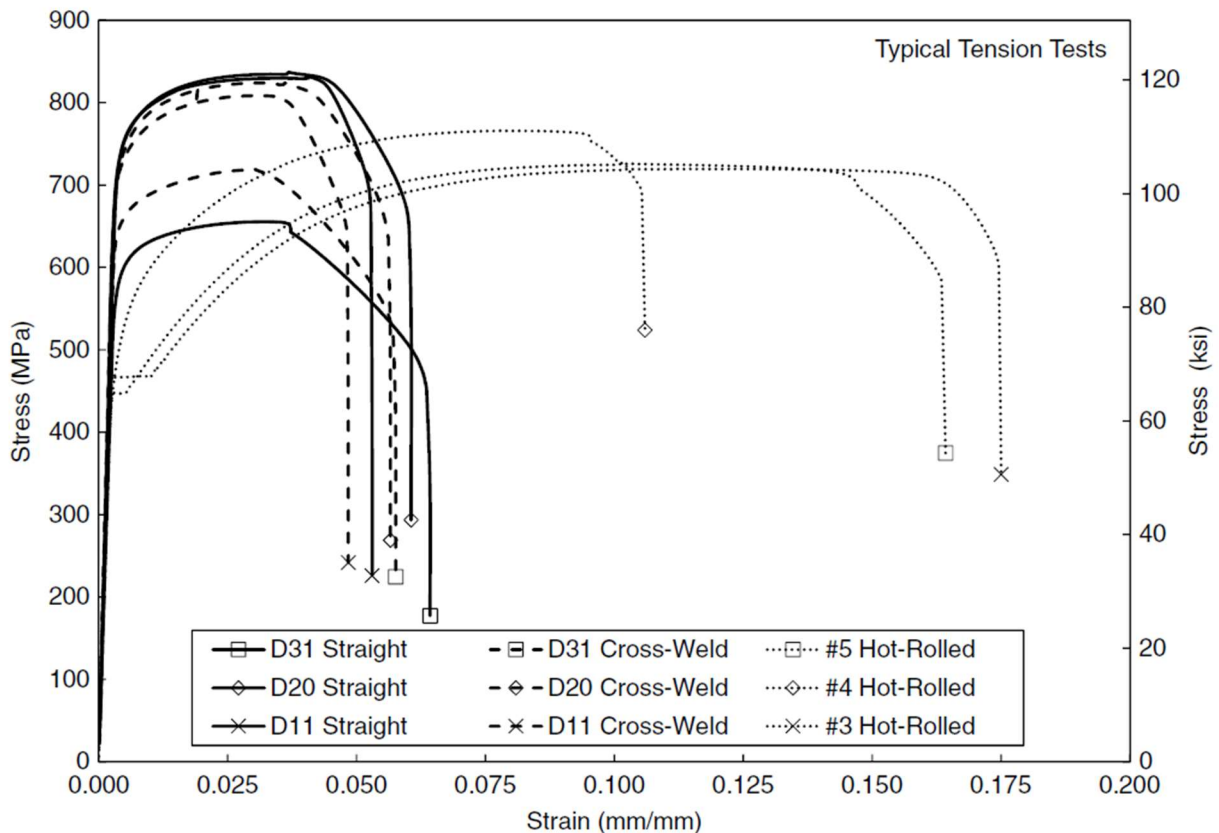

Figure 2-3 Stress strain curve of conventional reinforcement and WWR with and without a cross-weld (Yount et al. 2021)

WWR specimens that satisfy the current AASHTO requirements have been shown to exhibit strains large enough to redistribute stresses to prevent such a sudden brittle failure as supported by Morcous et al. (2011) and Griezic et al. (1994). Tempering can be used on WWR to greatly increase the ultimate strain, but the tempering process reduces the yield strength and fatigue life of the WWR (Ayyub et al. 1994b).

2.3.3 Fatigue Resistance

The AASHTO LRFD Bridge Design Specification has special requirements for fatigue of transverse WWR with a cross-weld in the high-stress region. WWR, without such cross-welds, is treated the same as typical reinforcement for fatigue requirements. The commentary points out that under service conditions, the critical stress range in the steel is minimal. It continues to say that fatigue is not a concern for prestressed members with WWR when the welded joints are located only in the girder flanges. No

welded joints are permitted other than those required for wire anchorage/development. When the smaller wire is within 40 percent of the area of the larger wire, ASTM A1064 requires weld shear strength based on the size of the larger wire. Where deformed wire does not meet this area requirement, the weld shear strength is only required to be 800 lbs. When welds are used for development or curtailment, the smaller wire must have an area within 40 percent of the larger wire (AASHTO 2020).

AASHTO's (2020) design philosophy for fatigue resistance is to limit the stress ranges of the concrete and steel to levels where infinite cycles are possible. These endurance limits are set according to the limit of the weakest component. WWR's cross-welds are particularly weak to fatigue loadings leading to reduced fatigue strength when these welds are located in the high-stress regions. When WWR is used as shear reinforcement, the high-stress regions are the clear web height between the fillets or the middle two-thirds of the member depth (Amorn et al. 2007). This reduction of fatigue strength occurs as a parallel shift with the same stress range resulting in fewer cycles to fracture (Ayyub et al. 1994c).

Tack-welds on WWR are capable of resisting fatigue loads higher than the fatigue resistance for WWR specified by AASHTO (2020) for when a cross-weld is in a high-stress region. This phenomenon is explained by the observation that electro-welds, which the code is based on and are used during manufacturing, develop fatigue weakness under fewer cycles compared to tack-welds. Should a tack-weld fail in fatigue, it does so smoothly, unlike an electro-weld. This resulting smooth notch left when a tack-weld fails has no functional effect on the fatigue life of the primary wire (Iordachescu et al. 2019).

2.4 WWR AS SHEAR REINFORCEMENT IN CONCRETE

This section focuses on the behavior of concrete members with WWR as shear reinforcement. The performance of these members is compared with those reinforced with typical reinforcing bars in the areas of shear strength, fatigue strength, development requirements, and ability to control cracking.

2.4.1 Shear Strength

Research on the performance of WWR shear reinforcement in prestressed beams under monotonic loading shows that WWR is as effective as conventional bar stirrups for shear strength. Xual et al. (1988) found that the stress concentrations caused by tack-welding did not impact the effectiveness of WWR as shear reinforcement under monotonic loads, despite the reduction of ductility. This result includes when a crosswire is placed in the center of the transverse reinforcement. Griezic et al. (1994) found that Grade 75 (500 MPa) WWR matching current strain requirements achieves shear strengths in accordance with the increase in the steel grade, and the failures are ductile. Due to these characteristics, WWR can be designed at least up to Grade 75 (500 MPa). Morcous et al. (2011) found that high-performance concrete I-girders reinforced with grade 80 WWR can provide shear capacities similar to ultra-high-performance concrete I-girders with more consistent and predictable results. Overall, WWR as shear reinforcement is as effective as conventional bar stirrups for shear strength, as supported by testing done by Durrani and Ian (1987), Mansur et al. (1987), Morcous et al. (2011), and Griezic et al. (1994).

2.4.2 Fatigue Strength

The AASHTO LRFD Bridge Design Specification (2020) has special requirements for fatigue of transverse WWR with a cross-weld in the high-stress region. WWR without such cross-welds is treated the same as typical reinforcement. The commentary points out that under service conditions, the critical stress range in the steel is minimal. It also says that fatigue is not a concern for prestressed members where the WWR used only has welded joints in the low-stress regions. No welded joints are permitted other than those required for anchorage/development.

Pincheira et al. (1989) tested concrete beams reinforced with deformed WWR, smooth WWR, and typical reinforcing bar stirrups under cyclical loading. The deformed WWR, in Series A, fractured under fewer cycles compared to the typical bar stirrups. During this test, however, the failure of the beams occurred after the reinforcement fractured due to arch action causing the crushing of the web. This continued strength led to the girder reinforced with standard bar stirrups and the girder reinforced with WWR failing at similar loads. In the non-prestressed beams tested in Series C, shear-

compression failure was reached for the beam reinforced with WWR causing failure under a lower stress range and a fewer number of cycles compared to the beam with typical reinforcement.

These tests suggest that deformed WWR is not as effective as typical reinforcing steel when used as transverse reinforcement under cyclic loading, in terms of number of cycles for prestressed beams (Pincheira et al. 1989). However, Series A compares a single leg of WWR with a double legged stirrup of typical reinforcement. The typical reinforcement had a shear capacity ($A_v f_y$) of 22.3 kN (5.0 kips) compared to the WWR stirrup of 16.1 kN (3.6 kips) using an f_y of 535 MPa (75 ksi) for WWR. Under the loading scheme shown in Figure 2-4, the WWR failed after 140,000 cycles under a load of 120 kN (27 kips) which corresponds to the expected capacity of the WWR according to Figure 2-5. The typical reinforcing bar stirrups failed after 200,000 cycles under a load of 150 kN (34 kips). This load is similar to the expected shear capacity of these stirrups as well. This suggests that the difference between WWR and typical reinforcing bar stirrups in Series A corresponds to the difference in capacity between schemes rather than poor performance of WWR. If early fracture is due to poor performance, it is less than it first appears due to this discrepancy in capacity between stirrups.

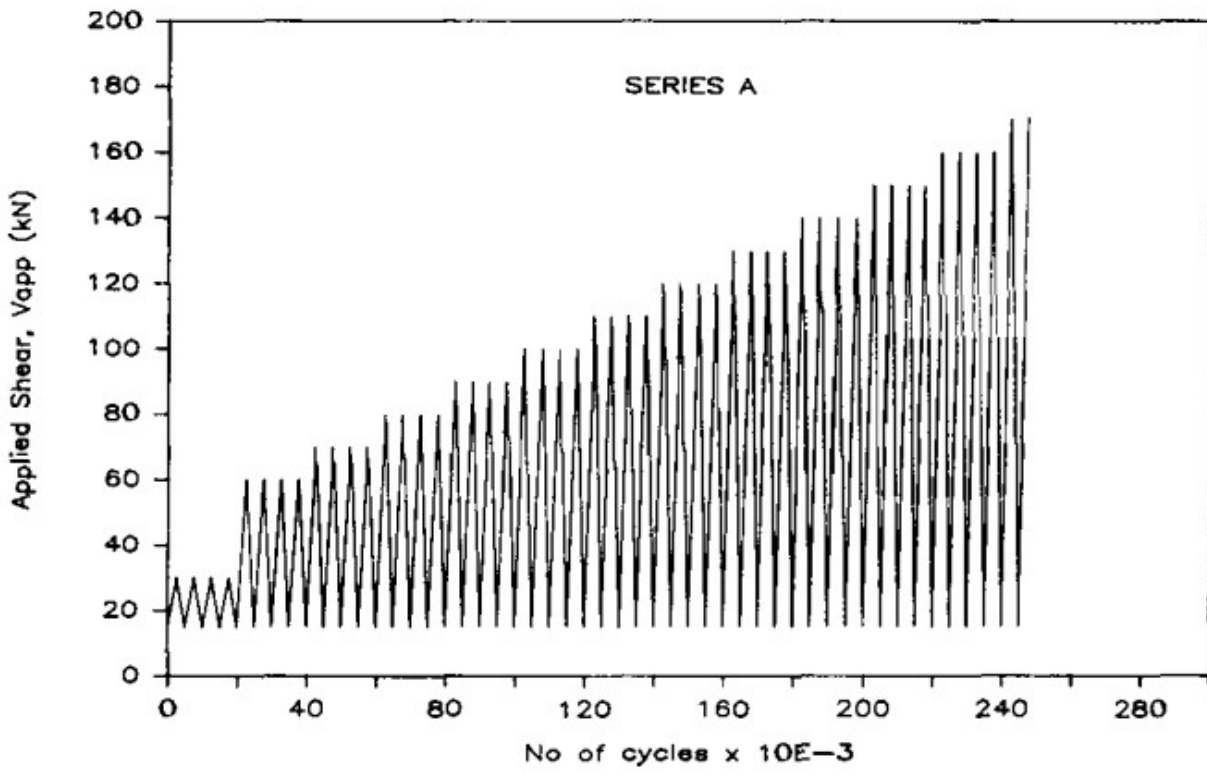

Figure 2-4 Cyclic loading scheme for Series A in Pincheira et al. (1989)

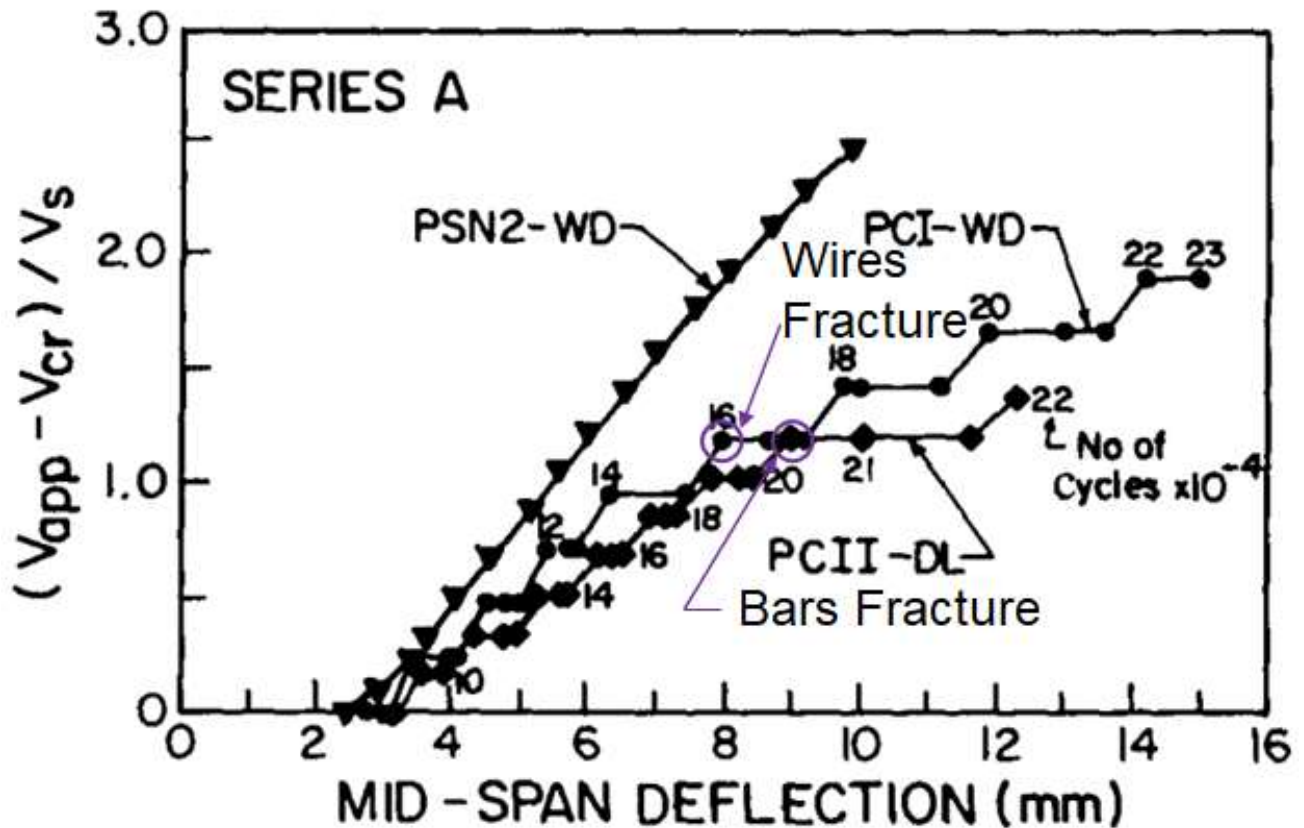

Figure 2-5 Load-deflection curve for Series A, where the applied shear is normalized to the expected shear reinforcement capacity (adapted from Pincheira et al. 1989).

V_{app} is the shear force applied as measured and V_{cr} is the shear force that caused cracking in the concrete as measured. V_s is the expected additional shear capacity provided by the stirrups. A value of 1.0 represents the stirrups reaching their expected capacity. PSN2-WD is a static load test with WWR stirrups. PCI-WD is a cyclic load test with WWR stirrups. PCII-DL is a cyclic load test with typical reinforcing bars as stirrups.

2.4.3 Development

For the development of transverse reinforcement, the AASHTO LRFD Bridge Design Specifications (2020) treats deformed wire, D31 and smaller, as the same as No. 5 bars and smaller. For single legged stirrups, deformed WWR may be developed like plain WWR as shown in Figure 2-6 or as deformed wire. U-stirrups using plain wire are to be developed as shown in Figure 2-7 with both sides developed with the second

wire allowed beyond or on a bend with an inside diameter not less than eight wire diameters. The standard of two crosswires at the top and bottom of a single-legged WWR stirrup for development is from the Joint PCI/WRI Ad Hoc Committee (1980).

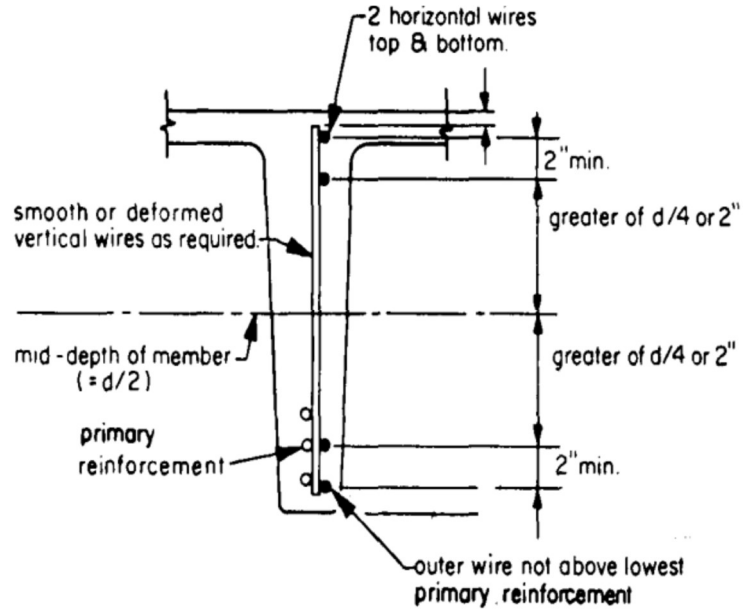

Figure 2-6 Development of WWR as a single leg [C5.10.8.2.6c-1] (AASHTO 2020)

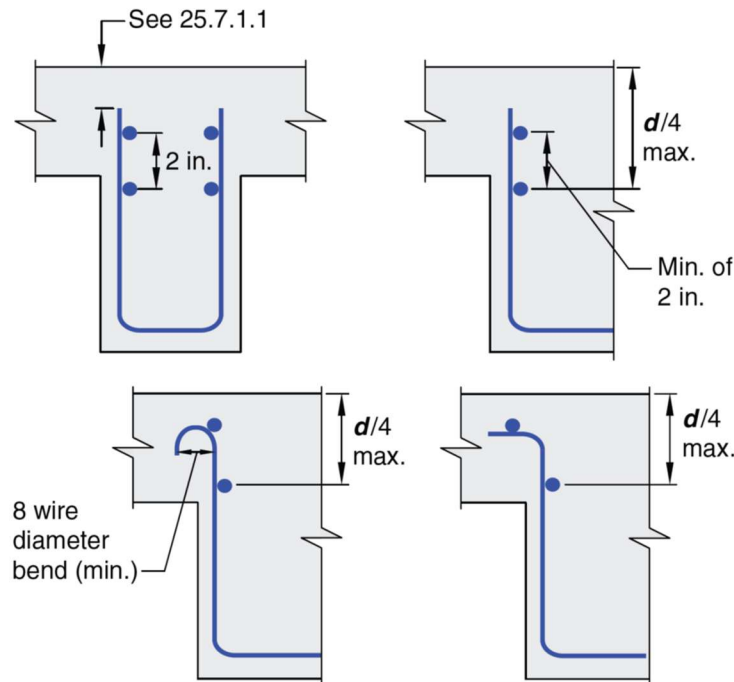

Figure 2-7 Development of plain WWR stirrups (American Concrete Institute Committee 318 2019)

Thin webbed members are problematic for development of transverse reinforcement. Due to their small web thickness only one layer of reinforcement can be used, preventing U-shaped stirrups. In addition, the use of hooks in the web can cause cover and congestion issues. WWR's ability to be developed by means of two horizontal wires at the top and bottom has become a significant benefit (Durrani and Ian 1987).

The use of using two horizontal wires at the top and bottom of the web to develop WWR is supported by testing reported by Durrani and Ian (1987), Mansur et al. (1987), Xuanl et al. (1988), Morcoux et al. (2011), and Griezic et al. (1994) for monotonic loading and Pincheira et al. (1989) for cyclic loading. The use of two wires is important for cases where a shear crack develops across the weld leading to the potential fracture of that weld. Premature failure of the beam does not occur as a result of the loss of this weld due to the additional wire (Durrani et al. 1987). Figure 2-8, from Pincheira et al. (1989), shows the fracturing of one of the anchoring wires and the primary reinforcing wire. This supports the idea that only one surviving anchor wire is necessary to maintain the development of the transverse wire under cyclic loading as well. It also supports the decision to require two wires in case one fails prematurely.

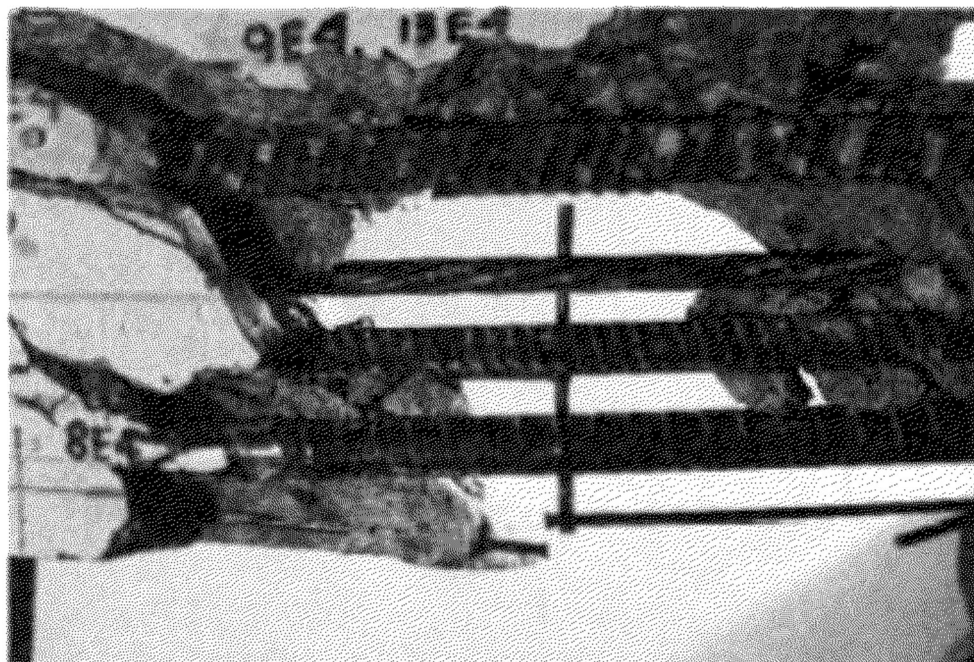

Figure 2-8 Fracture of transverse and longitudinal wire (Pincheira et al. 1989)

Weld quality is of critical importance for anchorage as poor quality leads to weakness in the surrounding wire causing premature failure near the weld (Durrani et al. 1987). The primary source of anchorage is confirmed to be provided by the welds and the cross wires according to pullout tests performed by Ayyub et al. (1994a). Mansur et al. (1987) found that slip values for U-shaped smooth WWR stirrups cross wires were less than one half of a millimeter. When deformed wires were used, the slip reduced further compared to the smooth wire.

2.4.4 Crack Control

Crack widths were found to be functionally the same for typical reinforcement, deformed WWR and smooth WWR. Typical crack patterns can be seen in Figure 2-9 with the type of reinforcement specified in Table 2-2. Slight differences in crack widths at high loading are likely caused by small variations between shear reinforcement quantity instead of type or configuration (Xuanl et al. 1988).

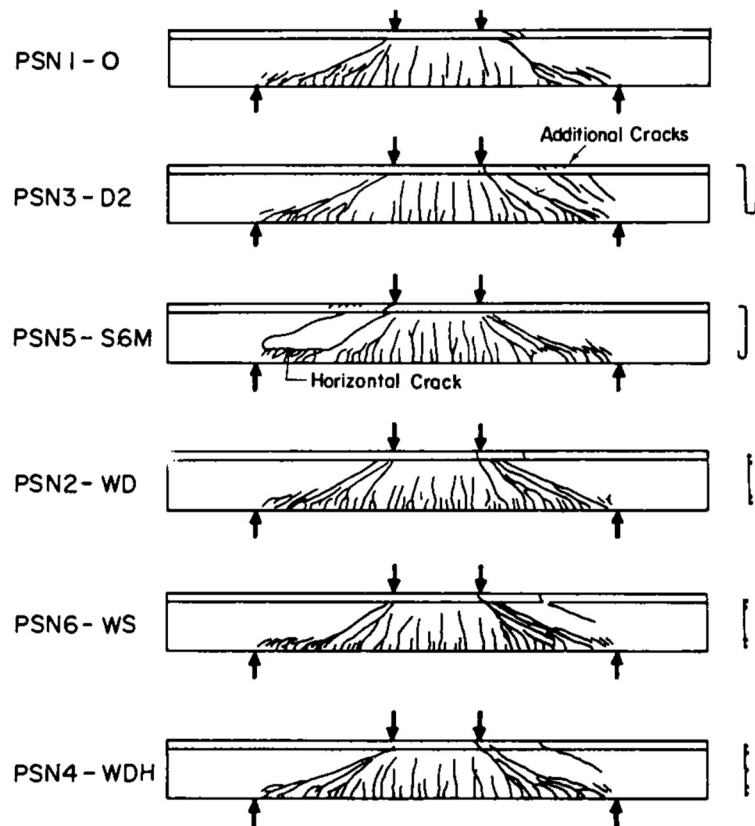

Figure 2-9 Typical shear crack patterns of beams (Xuanl et al. 1988)

Table 2-2 Reinforcement types present in Figure 2-7 (Xuanl et al. 1988)

NAME	TYPE OF REINFORCEMENT
PSN1 – O	No Transverse Reinforcement
SPN3 – D2	U-stirrup of conventional reinforcement
PSN5 – S6M	Single-legged stirrup of conventional reinforcement
PSN2 – WD	Deformed WWR
PSN6 – WS	Smooth WWR
PSN4 – WDH	WWR with a crosswire at mid-height

As seen in Figure 2-10, Mansur et al. (1987) found that deformed WWR performed better than smooth WWR and conventional bar stirrups. However, for these tests, the conventional bar stirrups were at a greater spacing than the WWR and the deformed WWR had a higher yield strength compared to the smooth WWR.

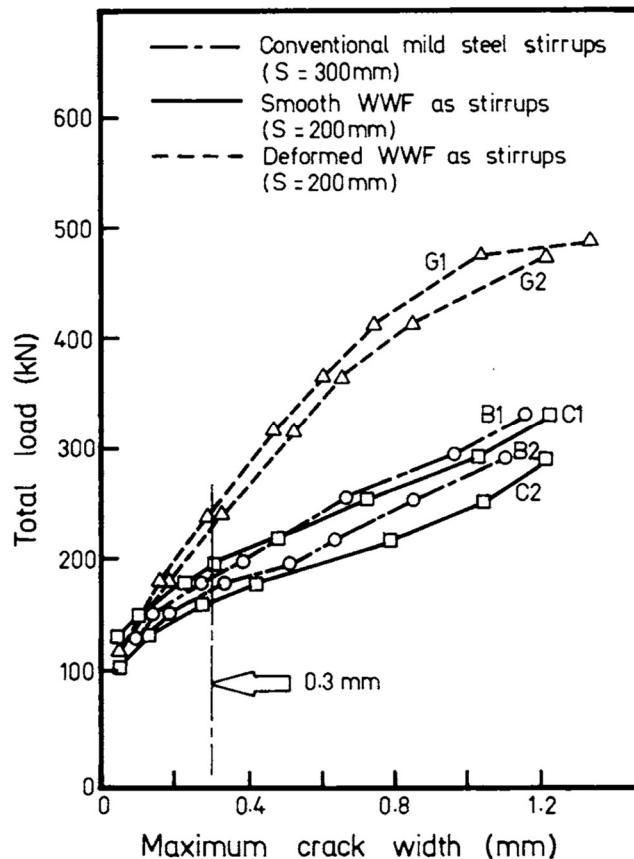

Figure 2-10 Maximum crack width vs total load (Mansur et al. 1987)

For cyclic loads as seen in Figure 2-11, Pincheira et al. (1989) found that deformed WWR performs slightly better than conventional bar stirrups for crack control in Series A, smooth WWR performs better than conventional bar stirrups in Series B, and deformed WWR performs nearly identically as conventional bar stirrups in Series C. Series A failed by crushing of concrete in the compression zone. Series B failed by fatigue of the prestressing reinforcement. Series C failed by shear-compression failure but were nonprestressed girders. Overall, deformed WWR behaves as well and perhaps slightly better than conventional bar stirrups for crack control.

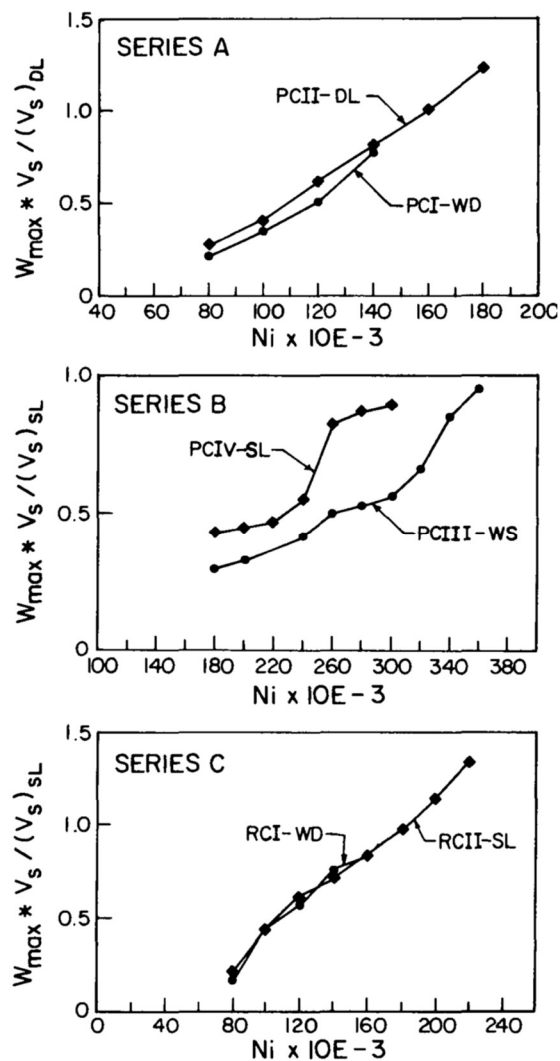

Figure 2-11 Maximum crack width against number of loading cycles (Pincheira et al. 1989)

2.5 CONCLUSIONS

WWR has a higher yield strength and lower ductility when compared to typical reinforcing bars. The yield strength increase is a product of the cold rolling process performed and the ductility loss is due in part to the higher yield strength and the presence of welds. These welds present a weakness to fatigue stresses that are not present for typical reinforcing bars. This weakness is codified in AASHTO as a reduction in the fatigue threshold for WWR when a cross-wire is in a high stress region. However, when used for shear reinforcement, WWR can easily be designed so that a weld is not present in the high shear region. There is evidence that suggests that tack-welds do not cause this fatigue weakness in the primary wire unlike electro-welds.

Despite WWR's reduction in ductility, under monotonic loadings WWR was found to perform as effective as conventional reinforcing steel for shear strength. High-performance concrete I-girders reinforced with grade 80 WWR can provide shear capacities similar to ultra-high-performance concrete. Under cyclic loading deformed WWR may not be as effective as typical reinforcing steel. However, the AASHTO LRFD commentary considers under service conditions that the critical stress range experienced by shear reinforcement is minimal. The development of WWR stirrups by two cross-wires as a replacement or in support of hooks is well supported to be sufficient for monotonic and cyclic loading. Deformed WWR appears to perform as good or possibly better at controlling shear cracks when compared to conventional reinforcing steel.

2.6 AASHTO LRFD WWR PROVISIONS

The AASHTO LRFD code (2020) has several provisions and commentary sections pertaining to the use of WWR in specific. These provisions and commentary are summarized in Table 2-3.

Table 2-3 Summarized AASHTO LRFD WWR Provisions (2020)

PROVISION	SUMMARY
[5.1]	Welded wire reinforcement falls under the scope of Section 5 Concrete Structures.
[5.4.3.1]	All reinforcing steel, including WWR, must conform to the material standards in Article 9.2 in the AASHTO LRFD Bridge Construction Specifications
[5.5.3.2]	The constant-amplitude fatigue threshold, $(\Delta F)_{TH}$, is the same for WWR and reinforcing bars as long as there is no cross weld in the high-stress region. In cases where there is a cross weld in the high-stress region, $(\Delta F)_{TH} = 18 - 0.36f_{min}$ showing a reduction.
[5.7.2.4]	<ul style="list-style-type: none"> • WWR is permitted as transverse reinforcement to resist shear if the wires perpendicular to the longitudinal axis of the member are “certified to undergo a minimum elongation of four percent, measured over a gauge length of at least 4.0 in. including at least one cross wire.” • A closed cage of WWR is permitted as transverse reinforcement to resist torsion
[5.7.2.7]	When WWR is used as transverse reinforcement it shall be anchored/developed in accordance with Article 5.10.5.2.6c. “No welded joints other than those required for anchorage shall be permitted”
C5.7.2.7	<ul style="list-style-type: none"> • Fatigue of WWR is not a concern in prestressed members as long as the WWR has welded joints only in the flanges where shear stress is low. • “Use of relatively small diameter deformed welded wire reinforcement at relatively small spacing, compared to individually field tied reinforcing bars, results in improved quality control and improved member performance in service.”
[5.7.4]	WWR is permitted to resist interface shear

[5.10.2.3]	Welded intersections cannot be located within four bar diameters of tight bends of WWR.
[5.10.4.3]	WWR is permitted for use as ties
[5.10.5]	WWR is permitted for use as compression reinforcement in flexural members
[5.10.6]	WWR is permitted for use as shrinkage and temperature reinforcement
[5.10.8.2.5]	The modified development length, l_d , for deformed or plain welded wire reinforcement for applications other than shear reinforcement is limited by cross-wire placement.
[5.10.8.2.6b]	Deformed D31 wire and smaller shall be anchored as No. 5 bars and smaller when used as shear reinforcement
[5.10.8.2.6c]	<ul style="list-style-type: none"> • Each leg of U shaped plain WWR stirrup shall be anchored by two wires • A single-leg stirrup of plain WWR shall be anchored by two wires at each end
[5.10.8.5]	Required lap splice length of deformed and plain WWR in tension

CHAPTER 3: STATE OF PRACTICE

3.1 INTRODUCTION

This chapter describes the current state of practice among state departments of transportation regarding the use of welded wire reinforcement (WWR) as shear reinforcement. The survey performed to determine this state of practice is outlined, and differences in state standards and drawings are discussed.

3.2 SURVEY

3.2.1 Introduction

A survey was designed to gauge the current WWR design practices of state departments of transportation (DOT). This survey was sent by email to people with relevant job titles working for state DOTs. Emails were found on state DOT websites. In addition to state DOT employees, Federal Highway Administration (FHWA) employees were emailed. The survey was sent out on September 23, 2021. Data was collected from respondents for twenty-three states as illustrated in Figure 3-1.

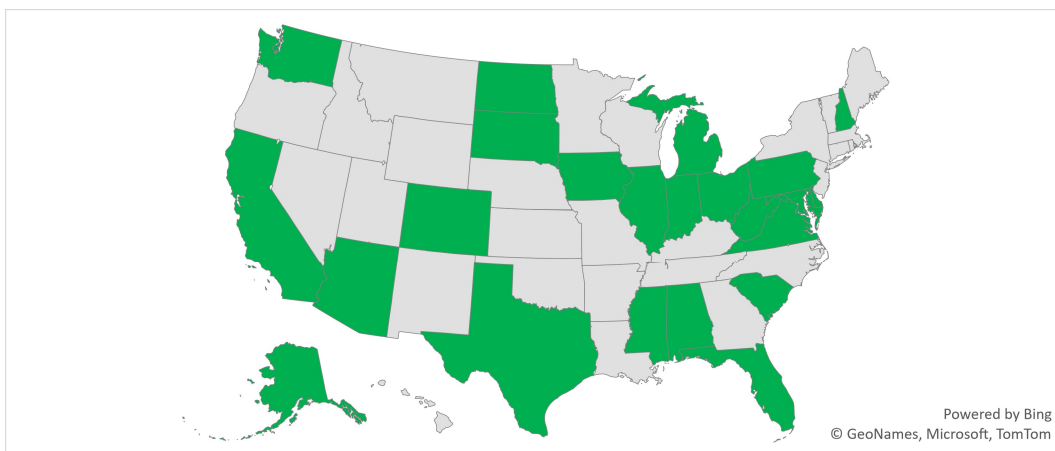

Figure 3-1 State respondents to WWR survey highlighted in green.

Respondents were asked if their state department allows WWR for

- shear reinforcement in precast, prestressed bridge girders,

- confinement of the bottom flange in the prestress transfer zone,
- supplemental web reinforcement in prestressed anchorage/transfer zones,
- shear reinforcement in non-prestressed bridge components,
- interface-shear reinforcement between the concrete girder and the concrete deck,
- or any other use.

Respondents could answer any of these options with

- yes,
- no, but potentially interested,
- or no, and not interested.

If the respondent answered yes to any category, the respondent was asked to provide any benefits, good practices, and challenges they had experienced in their use of WWR. If the respondent answered no to any shear reinforcement category, they were asked to provide reasons why they limited WWR as shear reinforcement. If the respondent answered yes to any shear reinforcement category, they were asked

- for shear reinforcement, does your organization prefer welded wire reinforcement or conventional reinforcing bars (stirrups),
- for shear reinforcement in girders, what design yield stress is used for welded wire reinforcement,
- What limitations (if any) does your agency impose on the use of WWR as shear reinforcement,
- does your agency use standards (drawings, details) that illustrate the use of WWR as shear reinforcement,
- and please provide a URL to locate these standards if available.

For the preference question, respondents had the option to choose between preferring welded wire reinforcement, preferring bars/stirrups, or no preference. The design yield stress question allowed respondents to choose multiple answers between 60, 70, 75, 80, greater than 80 ksi, and must use the same area and same (or smaller) spacing as equivalent reinforcing bars. The limitations question was open-ended. The first standards question was yes or no with the next question providing the ability to provide a URL. Regardless of answers, all surveys ended with the respondent being

asked to identify which state they represented and provide contact information suited for any follow-up questions.

3.2.2 Results

Of the states that are represented in the survey, the states that allow WWR as shear reinforcement in prestressed concrete bridge girders are shown in Figure 3-2. Some state DOTs who did not respond to the survey clearly showed allowance for WWR as shear reinforcement either on publicly available drawings or specifications. These states are included in addition to those that responded to the survey in Figure 3-3 for WWR allowance as shear reinforcement in prestressed concrete bridge girders. States investigated that showed no clear acceptance or prohibition of WWR were left blank.

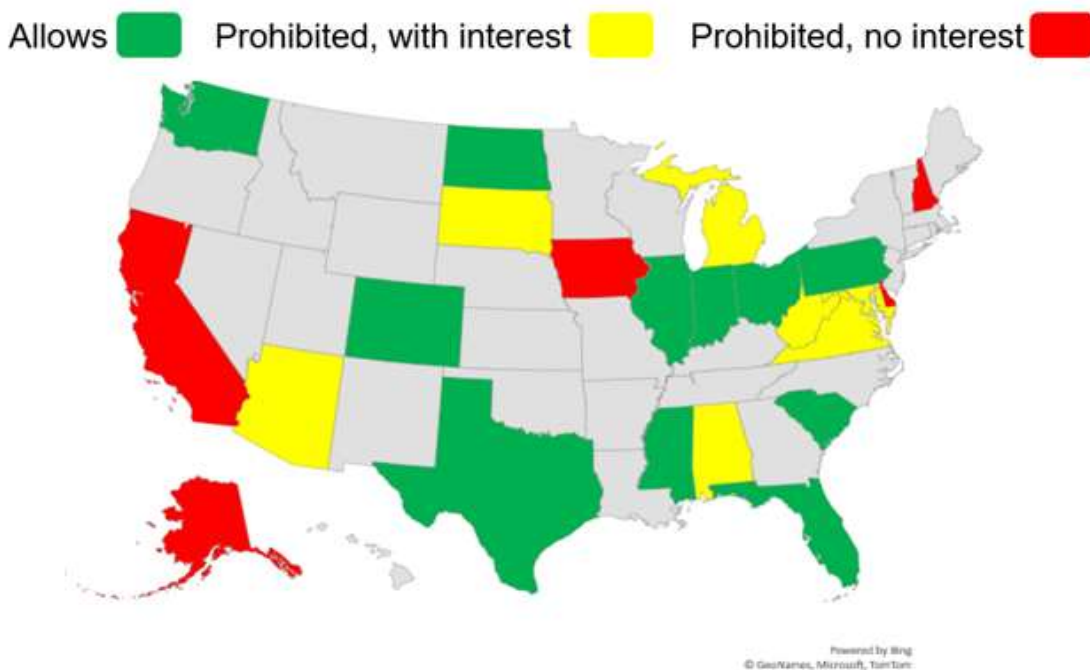

Figure 3-2 For survey respondents only, state allowance of WWR as shear reinforcement in prestressed concrete bridge girders

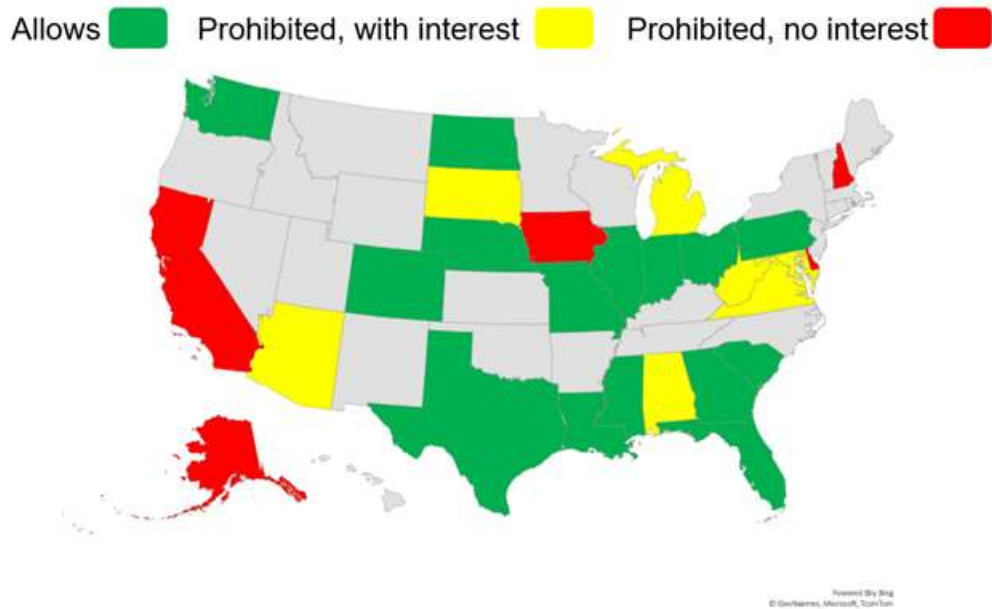

Figure 3-3 Including nonresponding states, state allowance of WWR as shear reinforcement in prestressed concrete bridge girders

Of the eleven states that answered the survey and allow shear reinforcement, 27 percent answered that they preferred WWR, 46 percent answered that they had no preference, and the remaining 27 percent answered that they preferred reinforcing bars. This preference is displayed in Figure 3-4.

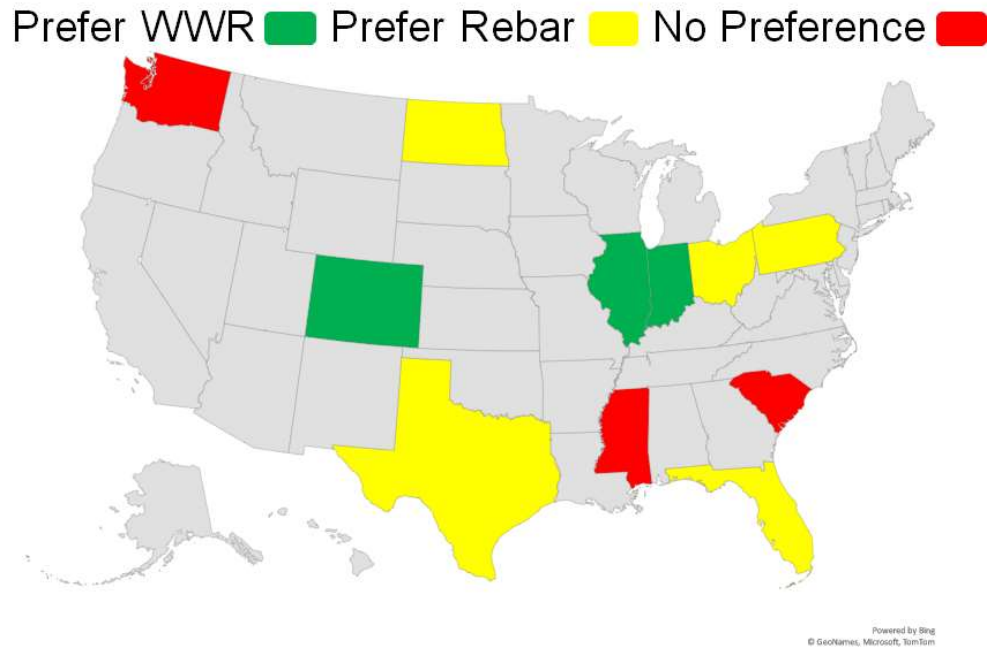
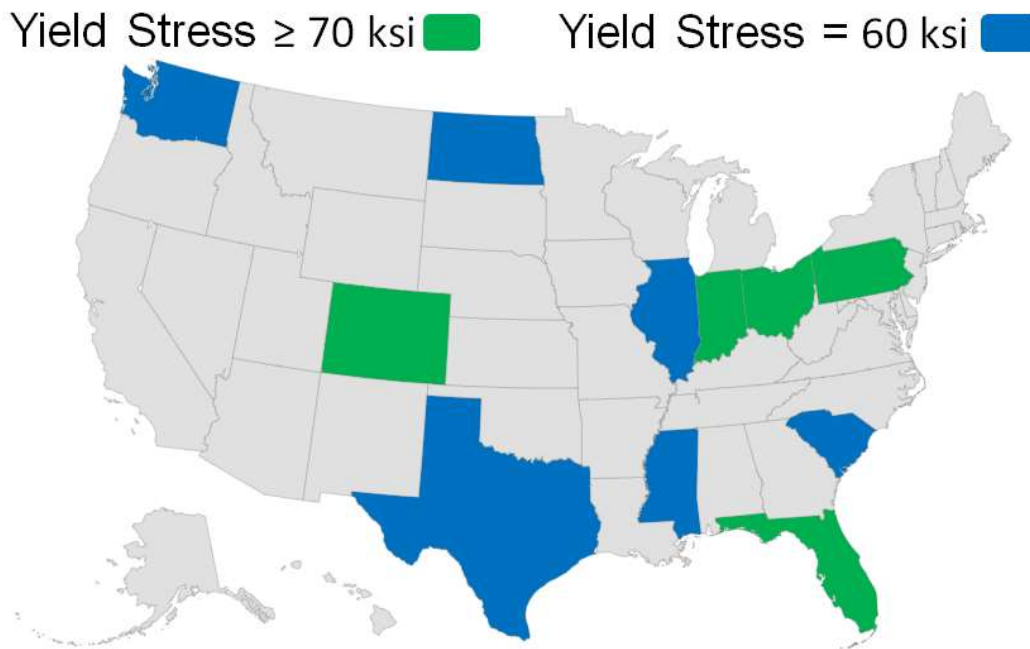

Figure 3-4 State shear reinforcement preference between WWR or reinforcing bars

Of the eleven states that answered the survey and allow shear reinforcement, 45 percent permit the use of a design yield stress at or above 70 ksi and 55 percent limit the design yield stress to 60 ksi. This is displayed in Figure 3-5.



Powered by Bing
© GeoNames, Microsoft, TomTom

Figure 3-5 Highest allowed design yield strength for WWR shear reinforcement

Of the eleven states that answered the survey and allow shear reinforcement, 55 percent have standard drawings that incorporate WWR, 36 percent do not have standard drawings that incorporate WWR, and Indiana was in the process of developing standard drawings containing WWR. This is displayed in Figure 3-6.

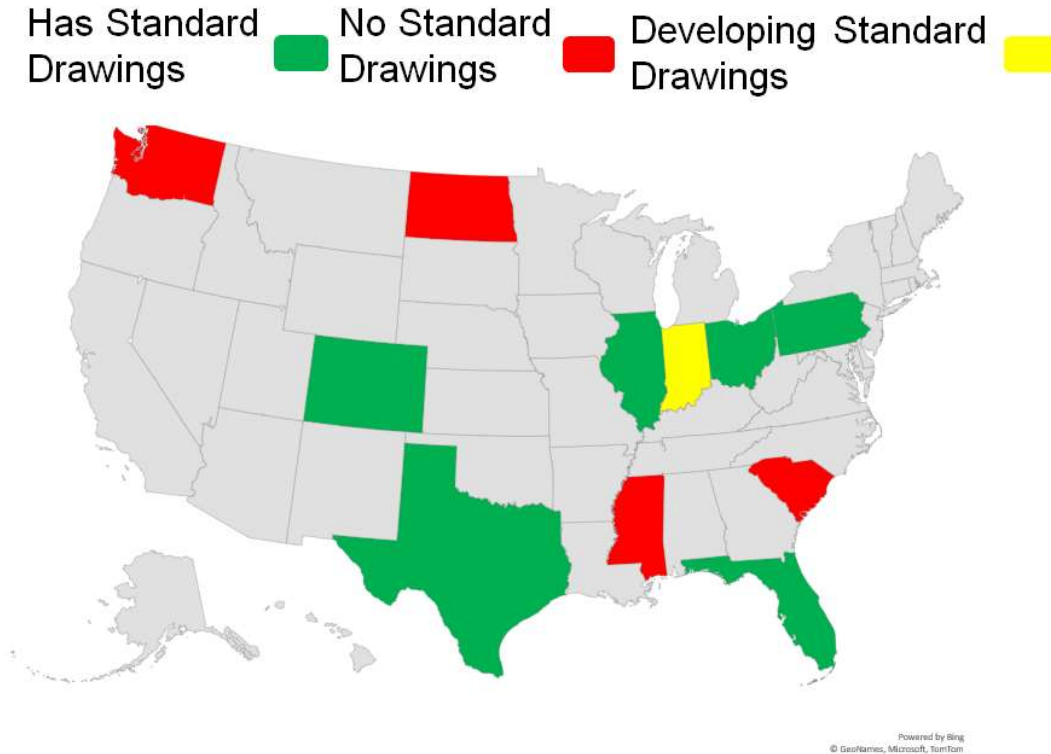

Figure 3-6 States with standard design drawings that incorporate WWR

Respondents that allow WWR as shear reinforcement were asked to provide common benefits, good practices, and challenges they faced related to WWR. Responses generally fell into the categories shown in Tables 3-1, 3-2, and 3-3. If a respondent listed multiple benefits, practices, or challenges, then that response was counted in each relevant category.

Table 3-1 Benefits cited by respondents in survey

<i>Cited Benefits</i>	<i>No. of Responses</i>
Convenient/rapid installation	4
Improved placement consistency/accuracy	3
Shorter development (eliminates bottom hook)	3
Smaller wire diameters reduce congestion	2
Useful for large amounts of repetitive reinforcement	2

Table 3-2 Challenges cited by respondents in survey

<i>Cited Challenges</i>	<i>No. of Responses</i>
Epoxy coating is difficult to achieve	2
Longer lead times and higher material cost	2
Difficult to quantify strength without coupon testing	1
Bursting shear in large beams may require WWR and reinforcing bar combinations	1
Complex splicing	1

Table 3-3 Good practices cited by respondents in survey

<i>Good Practices</i>	<i>No. Of Responses</i>
Create standard details, especially for lap splices	3
Allow substitution between WWR and reinforcing bars	1
Delineate deformed and smooth wire	1

Any respondents that indicated that they limit the use of WWR as shear or interface-shear reinforcement in prestressed or nonprestressed girders were given the option to explain why. Five respondents said they were satisfied with their current details, and Indiana cited a lack of codified guidance as the explanation for their restriction on the use of WWR for interface-shear. Responses related to the allowance of WWR as confinement of the bottom flange in the prestress transfer zone, supplemental web reinforcement in prestressed anchorage/transfer zones, shear reinforcement in nonprestressed bridge components, and interface-shear reinforcement between the concrete girder and the concrete deck are shown in Figures 3-7 through 3-10.

Allows ■ Prohibited, with interest ■ Prohibited, no interest ■

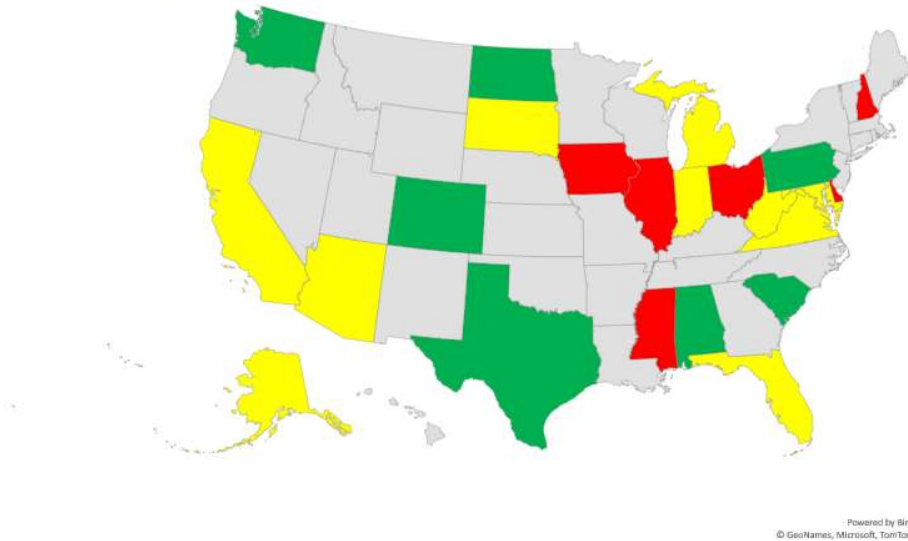
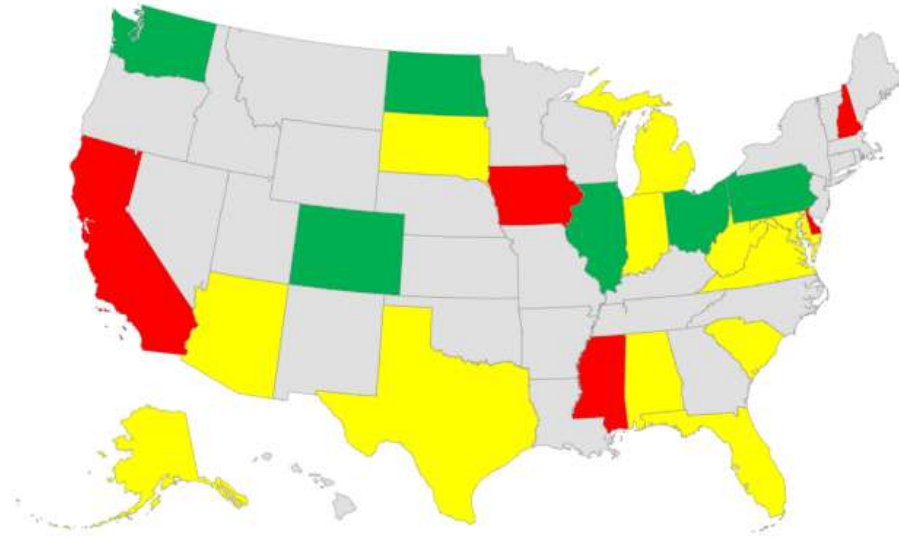

Figure 3-7 State allowance of WWR as confinement of the bottom flange in the prestress transfer zone.

Allows ■ Prohibited, with interest ■ Prohibited, no interest ■



Powered by Bing
© GeoNames, Microsoft, TomTom

Figure 3-8 State allowance of WWR as supplemental web reinforcement in prestressed anchorage/transfer zones

Allows ■ Prohibited, with interest ■ Prohibited, no interest ■

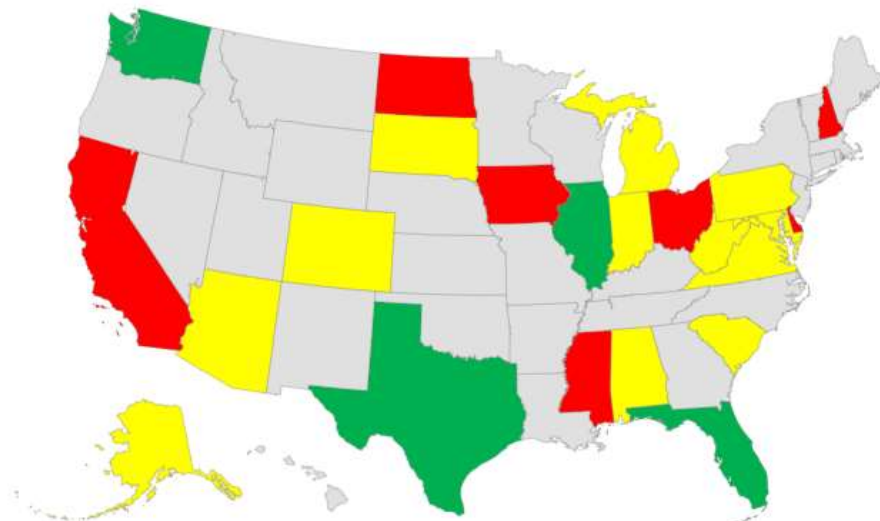
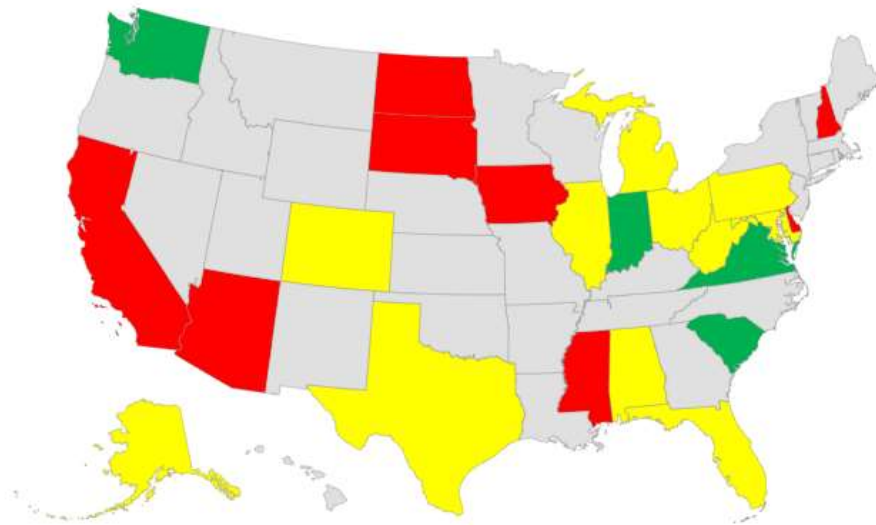

Figure 3-9 State allowance of WWR as interface-shear reinforcement between concrete girder and deck

Allows ■ Prohibited, with interest ■ Prohibited, no interest ■



Powered by Bing
© GeoNames, Microsoft, TomTom

Figure 3-10 State allowance for WWR as shear reinforcement in nonprestressed bridge components

3.2.3 Conclusions

WWR is not widely adopted as shear reinforcement among state DOTs, but there is considerable interest in its adoption. Of the states that do permit its use, preferences are split among WWR and reinforcing steel with most states having no preference between the materials. The states that prefer WWR have or are developing standard drawings for WWR and all the states that prefer reinforcing bars lack standard drawings. State DOTs are evenly split on using an increased design yield stress for WWR. WWR was reported to have longer lead times, higher material cost, and difficulty with epoxy coating. The recommendation for standard details may alleviate the lead times and material cost if they enable bulk orders. The difficulty with epoxy coating may explain the reduction in WWR allowance for interface-shear reinforcement. WWR's most cited benefits of rapid installation and improved placement occur during its implementation.

CHAPTER 4: IMPLEMENTATION OF WWR SHEAR REINFORCEMENT

4.1 INTRODUCTION

This chapter discusses the constructability aspect of welded wire reinforcement (WWR). How to best utilize the benefits of WWR for constructability is discussed in terms of stirrup shape/configuration, anchorage/development, and standardization. As part of this research, Dexter Ladner and Ben Spruill, engineers at Gulf Coast Prestress Partners (GCP), were interviewed about operations involving WWR in precast, prestressed girders. GCP creates precast, prestressed concrete girders for the states of Texas, Louisiana, Mississippi, and Alabama. The interview involved a tour of the GCP precast plant in Pass Christian, Mississippi. During this tour, a prestressed girder utilizing WWR as shear reinforcement was being constructed. GCP was working with the Louisiana Department of Transportation and Development (LaDOTD) and Mississippi Department of Transportation (MDOT) to use WWR in standard sheets for their shear reinforcement.

4.2 Fabrication and Installation

WWR is fabricated in sheets of wire. When utilized as shear reinforcement, these sheets contain primary wires which provide the required (vertical) shear resistance and cross-wires that hold the primary wires together and provide the development/anchorage of the primary wires as discussed in Chapter 2. An example WWR sheet that would be used for shear stirrups is presented in Figure 4-1. This WWR sheet would have a 180-degree bend around its axis of symmetry creating a series of 2-legged stirrups. This sheet after bending can be seen stacked in Figure 4-2. Figure 4-3 shows these sheets placed in a girder, and Figure 4-4 shows a cross section of a girder reinforced with the same sheets.

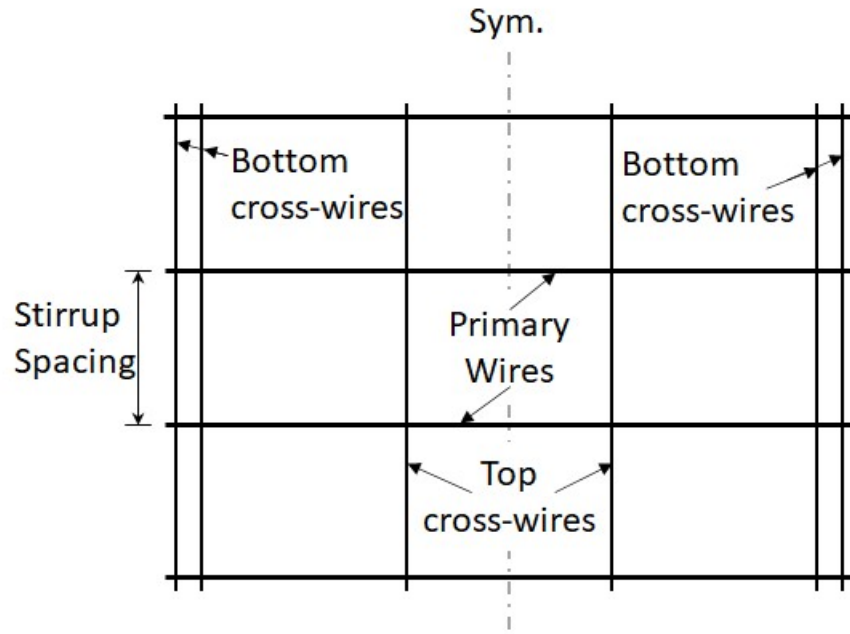

Figure 4-1 Typical WWR U-stirrup sheet prior to bending

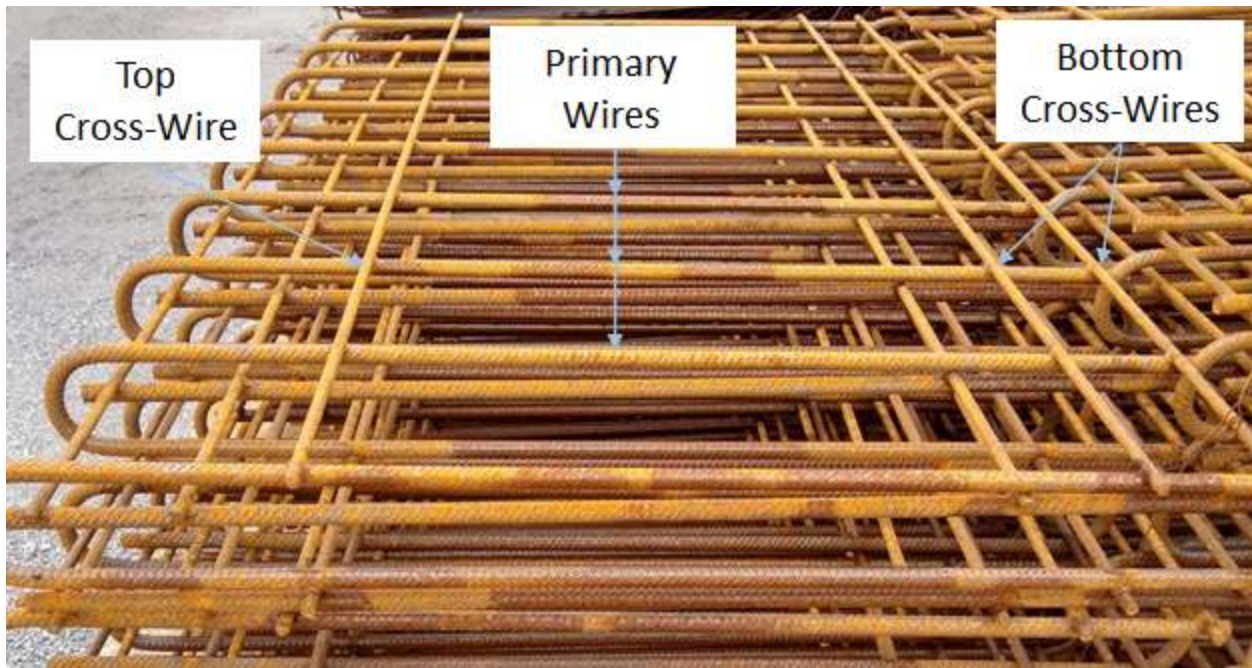

Figure 4-2 Stack of WWR U-stirrup sheets after bending.

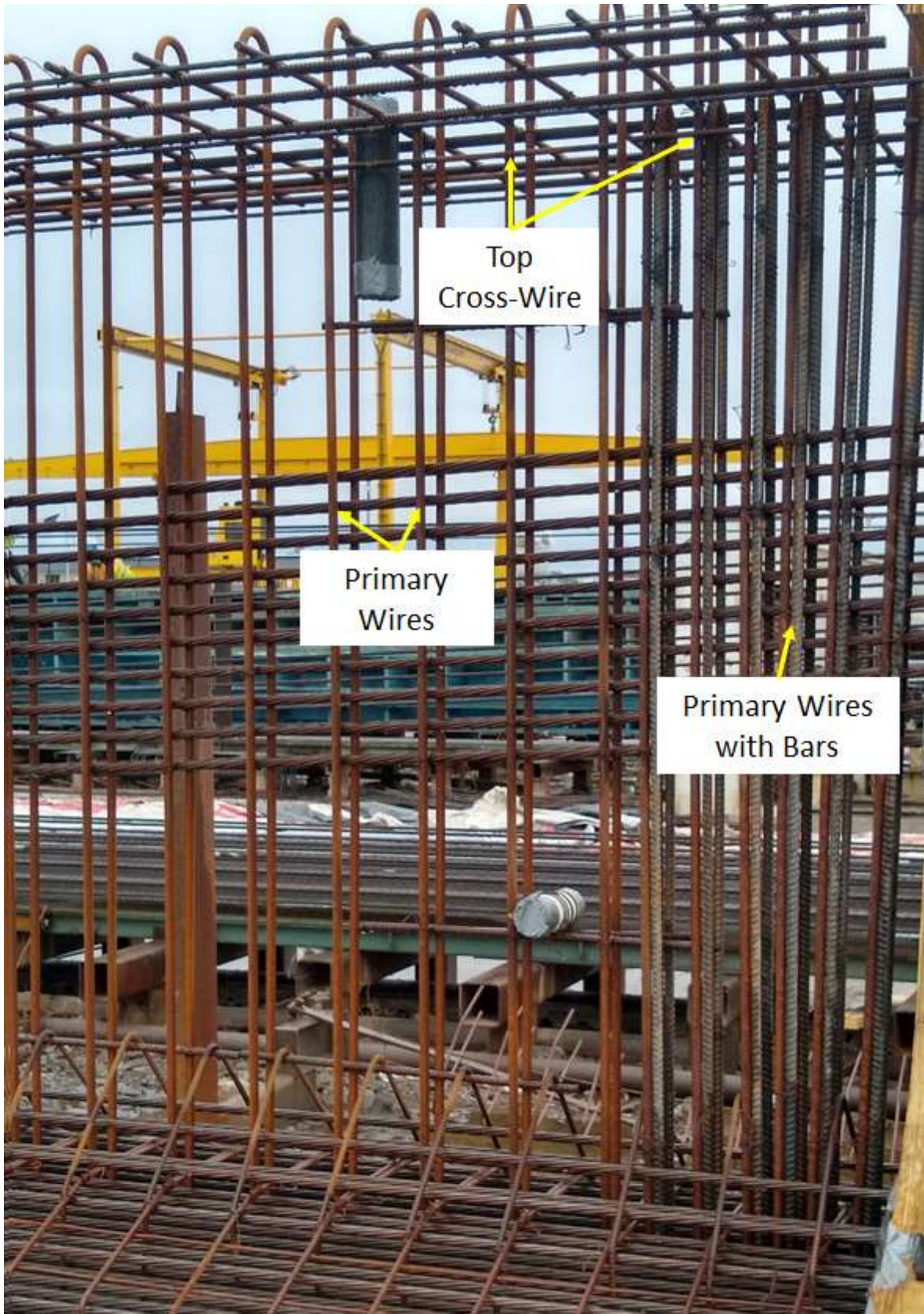

Figure 4-3 WWR stirrups placed in girder.

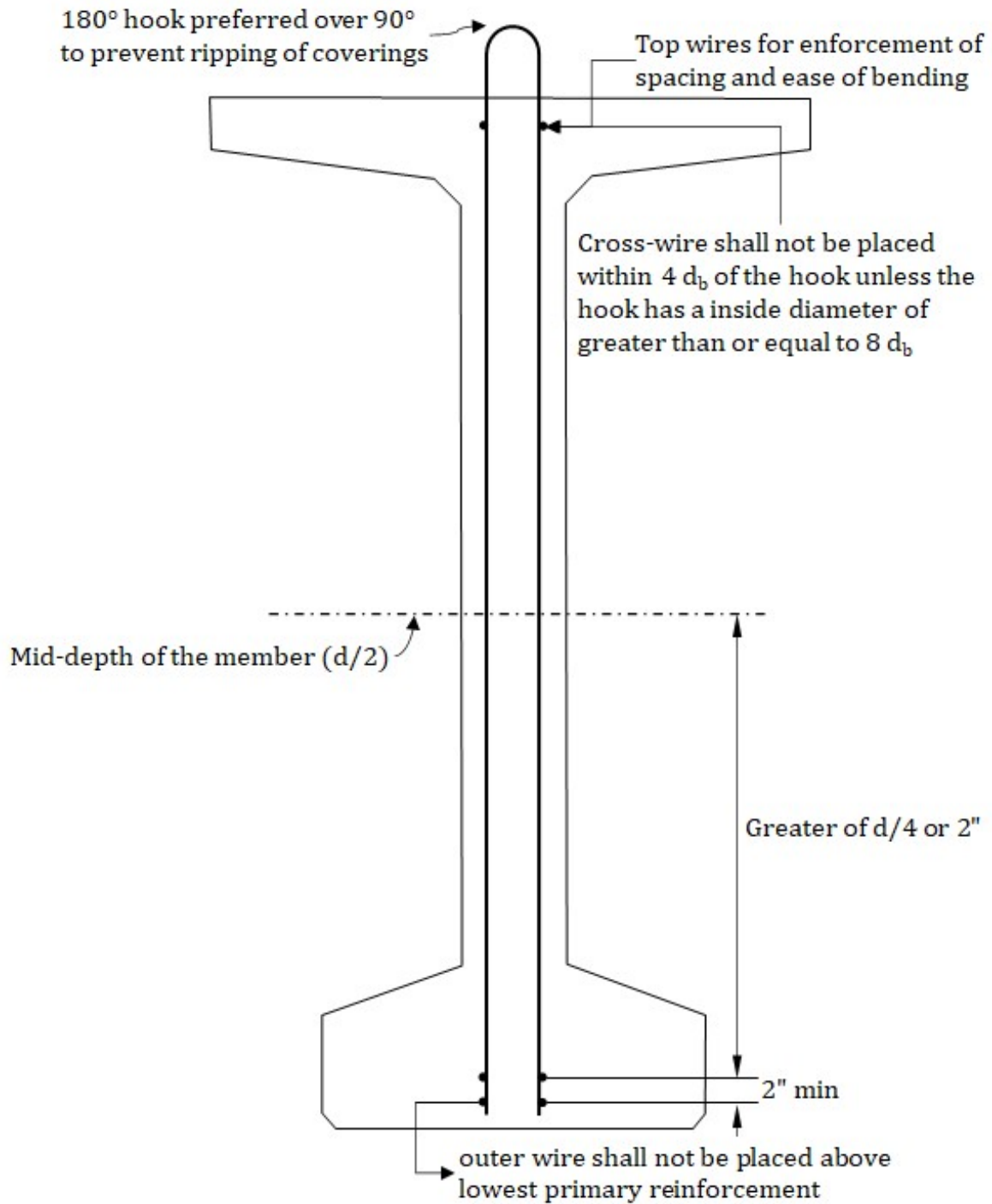

Figure 4-4 Example WWR U-stirrup cross section showing AASHTO (2020) requirements for placement of cross-wires

The bending of the WWR sheet can occur either on site (in the precast plant) or by the WWR manufacturer. If done on site, the top cross-wires close to the bend can be used as a guide and grip to ensure the middle of the bend coincides with the middle of the sheet. Once bent, the WWR sheets are ready to be slotted into their final position after the prestressing strands are in place and tensioned. Shear reinforcement is placed after the prestressing strands because threading prestressing strands through shear reinforcement is a difficult and time-consuming process. Due to WWR sheets including many stirrup legs of a uniform spacing, placing a WWR sheet in the girder takes less time compared to using typical reinforcing bar stirrups, because each bar stirrup must be individually aligned and tied off. Figure 4-5 compares the estimated time spent placing WWR stirrup sheets versus typical reinforcing bars.

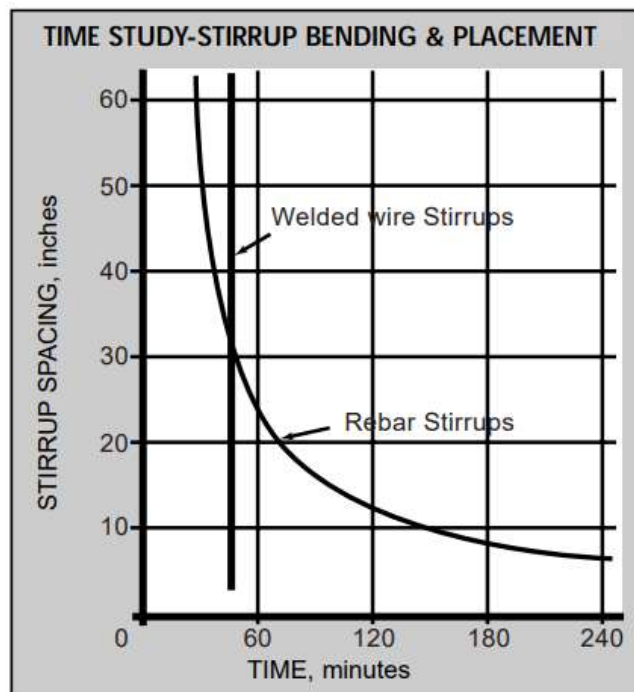

Figure 4-5 Time savings from using WWR on bending and placement (Wire Reinforcement Institute 2003).

According to Figure 4-5, WWR is preferable in terms of time for stirrup spacings of up to 30 inches. Since the maximum spacing allowed according to AASHTO LRFD (2020) is 24 in. for girders (and ALDOT currently limits stirrup spacing to 18 in.), WWR

is always preferable over reinforcing bars for placing time. This faster placing speed is the main cost-saving benefit of WWR stirrups. The faster placement saves work hours leading to labor cost savings. Most importantly, this is time saved *on the prestressing bed* in the daily production process. Reduction of reinforcement placement time on the bed increases the margin of error in curing time available for the concrete to obtain sufficient strength in the desired 24-hour production schedule. It allows concrete to be placed earlier in the production day increasing the curing time of the concrete, thus allowing for the more efficient attainment of the desired prestress transfer strength by the following morning. Failure to achieve the desired concrete strength by the following morning due to a later placement of concrete will cause that prestressing bed to be unusable the next day as the prestressing strands cannot be cut and the girder removed until sufficient strength is obtained.

Since WWR comes in sheets with standard wire spacings, the quality of placement is also generally better than reinforcing bars due to more accurate bar spacings and a reduction of movement during concrete placement. In addition, certain potential flaws are effectively eliminated such as improper bending, misplacement of stirrups, and missing stirrups (PCI 2010; Bernold and Chang 1992).

4.3 Constructability Design Considerations

Since WWR sheets used for stirrups provide many stirrup legs at a uniform spacing, the use of these sheets is more efficient where stirrup spacings are standardized. Typically, WWR stirrup spacings are standardized at four levels of shear intensity: high intensity shear at tight spacings and the lowest intensity at the maximum spacing allowed. Several WWR sheet dimensions, such as sheet width and cross-wire location, are dependent on girder shape and size. Thus, standardizing these girder parameters allows for the same WWR sheets to be used across girders. This standardization allows WWR to be bought in bulk and held in stock with a reasonable expectation of future use. This property is important to WWR as sheets must be bought in large volumes. The ability to hold a stock also reduces the cost per sheet and any estimated price escalations for the fluctuation of steel price over time. WWR has a longer lead time,

typically one to three months, compared to reinforcing bars; however, having a stock of standard sheets minimizes the impact of this longer lead time.

Since WWR sheets include many same-spaced stirrups in a single unit, it is important to consider standard girder lengths of same-spaced stirrups to match with sheet lengths. Having variable lengths of spacings of WWR stirrups across girders of the same section will require the shortening of standard sheets to meet the specified number of spaces. This practice of standardization of both spacings and lengths of spacings is illustrated in the example standard drawing from the Texas Department of Transportation (TxDOT) in Figure 4-6. The Precast/Prestressed Concrete Institute (PCI 2010) concurs that standardization of WWR is ideal for its efficient use and improves quality control and assurance as the placement and inspection process is streamlined.

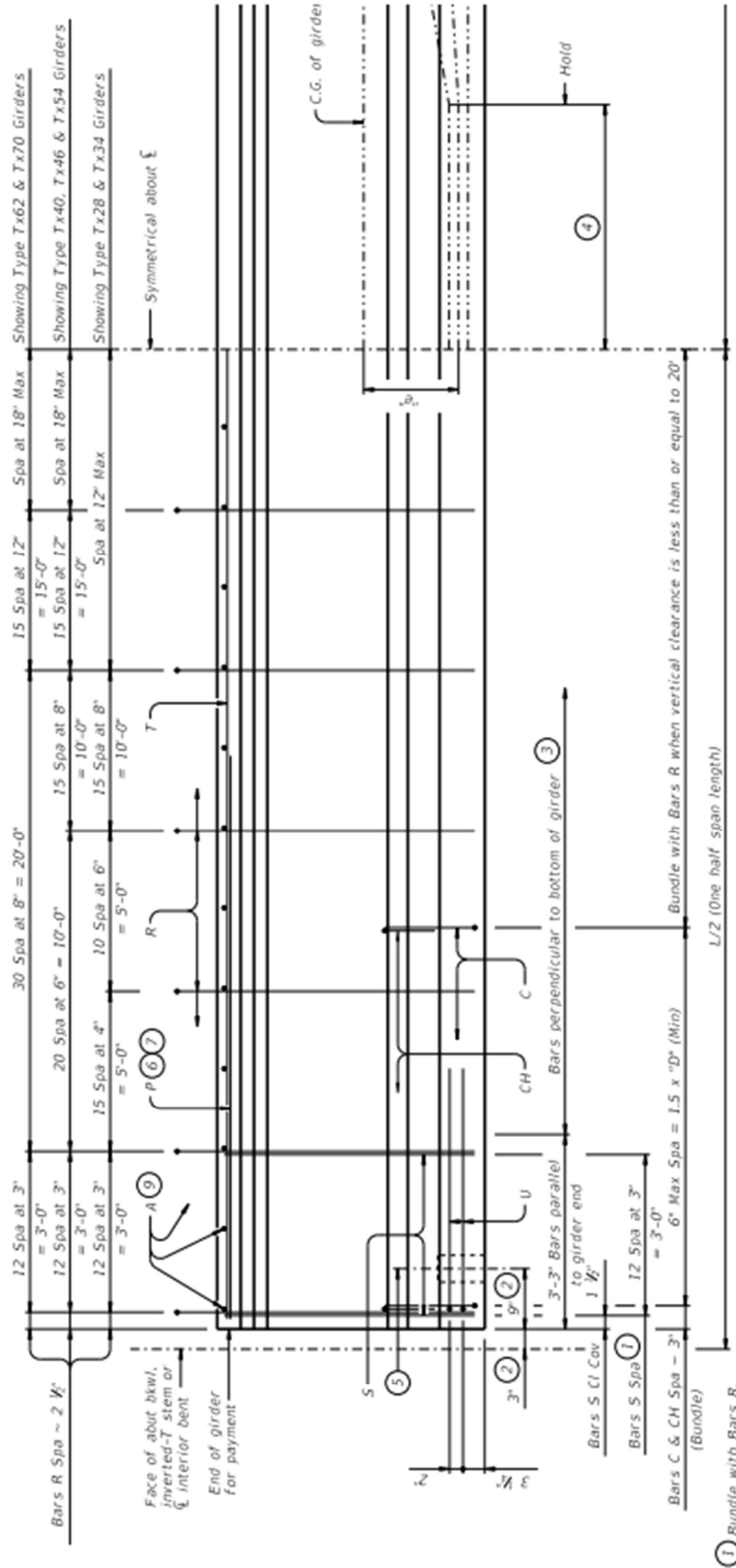

Figure 4-6 Standardized stirrup spacings and lengths for Texas I-girders (Texas Department of Transportation 2019)

WWR stirrups can be placed as single legs that are developed at the top and bottom by two cross-wires. However, for two-legged stirrups, providing a 180-degree hook at the top connects each leg, enabling one sheet to provide both legs leading to fewer sheets to place. This 180-degree hook, if used, is often extended above the top of the girder to resist interface-shear stresses between the girder and the deck. An example cross section of a typical two-legged WWR stirrup with this 180-degree hook is shown in Figure 4-4. When using a 180-degree hook at the top, cross-wires should be used for anchorage at the bottom. The absence of bottom hooks allows for the reinforcement to be easily dropped in over the prestressing strands. PCI (2010) notes that if WWR stirrups cannot be placed after strands are tensioned, then much of the cost-benefit of using WWR is lost. This unique development scheme for WWR eliminates the 90-degree hooks that are typical for bar stirrups made with reinforcing bars as shown in Figure 4-7. The top 90-degree hooks that project above the top of the girder are hazardous when the deck is cast in place as these hooks can catch the legs of persons walking on the top of the beam. These 90-degree hooks also tend to cause tears in the protective sheets that are used during the curing of the girder. These top 90-degree hooks are used for reinforcing bars instead of a 180-degree hook because an inverted U-stirrup with bottom 90-degree hooks, which are required to develop the bars, are very difficult to place after strands are tensioned compared to two separate bar stirrups with 90-degree hooks at top and bottom.

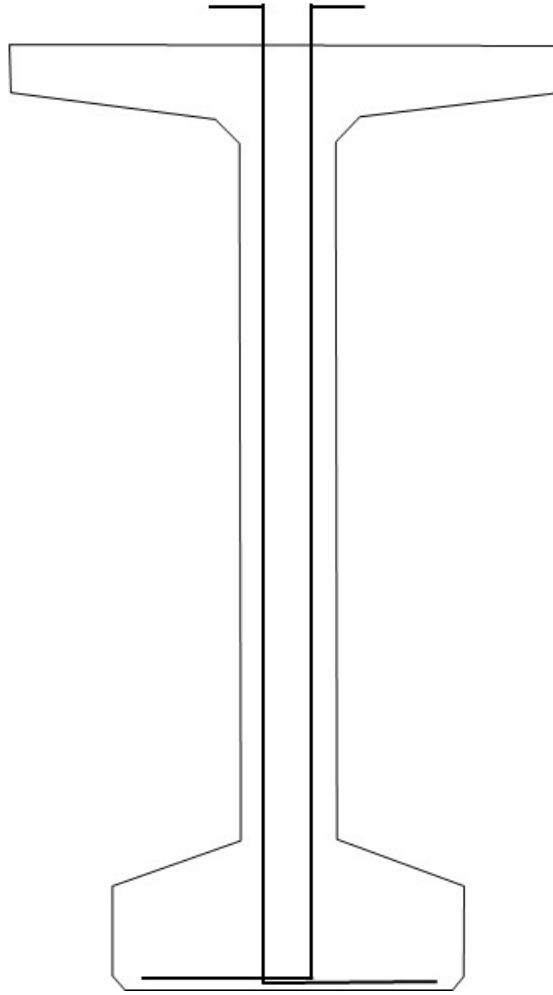

Figure 4-7 Typical reinforcing bar stirrup configuration.

Appendix A is a collection of drawings that show a variety of state department of transportation (DOT) WWR stirrup schemes. Several state DOTs use WWR stirrup schemes different than that presented in Figure 4-3. Instead, these states use single sheets of WWR, with some providing separate reinforcement for interface-shear and some using WWR with 90-degree hooks for interface-shear. It appears that states that use separate reinforcement for interface-shear require protective coatings, such as epoxy, for the steel that extends into the deck. The application of such coatings is likely difficult to obtain or achieve cost-effectively, as indicated by the survey results presented in Chapter 3.

CHAPTER 5: DESIGN COMPARISON—WWR VERSUS BAR STIRRUPS

5.1 INTRODUCTION

Transverse (shear and end zone) reinforcement configurations for four representative ALDOT precast, prestressed bridge girders were designed to illustrate potential benefits for designing with welded wire reinforcement (WWR). This chapter provides the design methodology used and the resulting designs. These four girder design scenarios were provided by the ALDOT Bridge Design Bureau for this study. These designs were compared with a typical ALDOT reinforcing bar stirrup layout for each girder to determine any potential benefits or drawbacks involved.

5.2 DESIGN METHODOLOGY

Shear designs were performed on four different girder section sizes with different lengths and prestressing reinforcement to determine the potential benefits of designing with WWR. These girders were initially selected by ALDOT for actual bridges with reinforcing bar stirrups in mind. Due to more stringent reinforcement requirements in ALDOT specifications compared to AASHTO (2020) specifications, each girder was designed in multiple variations ranging from satisfying all ALDOT and AASHTO requirements to satisfying only AASHTO requirements. Each variation in design requirements is labeled and described in Table 5-1 with the original bar stirrup layout substituted for WWR labeled as DRAW.

Table 5-1 Designation of design variations

VARIATION DESIGNATION	DESCRIPTION
DRAW	Bar stirrup layout as drawn by ALDOT substituted with WWR
AL5G60	Satisfies all ALDOT requirements with wire that has an equivalent area of a No. 5 bar (D31)
AL5G75	Satisfies ALDOT spacing requirements with grade 75 wire that has an equivalent yield force to a grade 60 No. 5 bar (D26)
AL4G60	Satisfies ALDOT spacing requirements with wire that has an equivalent area of a No. 4 bar (D20)
AL4G75	Satisfies ALDOT spacing requirements with grade 75 wire that has an equivalent yield force to a grade 60 No. 4 bar (D16)
5G60	Satisfies all AASHTO requirements with wire that has an equivalent area of a No. 5 bar (D35)
5G75	Satisfies all AASHTO requirements with grade 75 wire that has an equivalent yield force to a grade 60 No. 5 bar (D26)
4G60	Satisfies all AASHTO requirements with wire that has an equivalent area of a No. 4 bar (D20)
4G75	Satisfies all AASHTO requirements with grade 75 wire that has an equivalent yield force to a grade 60 No. 4 bar (D16)

Variations included ignoring each of the following ALDOT-specific requirements: (a) vertical shear reinforcement shall be no smaller than a No. 5 bar, and (b) shear reinforcement in the girder ends shall be spaced 4 in. on center and shall extend from the end of the girder for a distance equal to the girder depth. Where a Variation satisfies the ALDOT spacing requirement, it is labeled with AL. Where a Variation is based on a No. 5 bar size, it is labeled with a 5, and when based on a No. 4 bar size, it is labeled with a 4 instead. Variations were also made for WWR’s design yield stress either being taken as the same as reinforcing bars (60 ksi) or a design yield stress of 75 ksi. Where the design yield stress of 75 is taken, the wire size is reduced proportionally to the increase in design yield stress to maintain an equivalent yield force per stirrup. This was done so that the increase in design yield stress had effect when stirrups reached their maximum spacing.

The shear design was performed according to the Sectional Design Model as outlined in AASHTO (2020) using the shear strength as derived from the Modified Compression Field Theory. Each girder’s shear strength versus demand was checked at the face of the bearing, the end of the transfer length of the prestressing strands, the

“critical section” defined as a shear depth (d_v) away from the face of the support, and each tenth of the total length of the girder. Each girder was symmetrical, so values were only calculated to midspan. For interface (horizontal) shear, all girders were assumed to be intentionally roughened. Calculations performed are presented in Appendix B. Intermediate (transitional) stirrup spacings were selected to bridge the large spacing change that typically occurs toward the end of the girder on the original bar stirrup layouts. While such transitional stirrup spacings are present in the DRAW variation, the other variations are meant to show the minimum stirrups as required to provide adequate strength and satisfy their other reinforcement requirements. The addition of stirrups beyond this minimum may result in a larger factor of safety at an additional production cost.

Because WWR is often most efficiently used as standardized sheets, in addition to displaying each variation’s minimum stirrup layout, each variation was fitted with example standardized sheets. These standard sheets are described in Table 5-2. When fitting each variation, every sheet was taken to its full length until the sheet that covers the midspan of the girder. This sheet would need to be cut shorter in length for a symmetric stirrup design (or simply overlapped with the matching sheet on the other side midspan).

Table 5-2 Example Standardized Sheet Details

<i>Standard Sheet Details</i>		
Stirrup Spacing (in.)	Sheet length (ft.)	Stirrup Spaces (No.)
3	3	12
4	5	15
8	10	15
12	10	10
18	15	10
24	20	10

5.3 BT-74 MODIFIED SECTION, 166 FT LONG GIRDER

A BT-74 girder shape modified to have an extra 2 in. added to its width was considered. The cross section of the girder showing the strand layout and recommended WWR stirrup shapes at the end (Bars W1) and at the hold-down points (Bars W3) are shown in Figures 5-1 and 5-2. The girder was 166'-6 $\frac{3}{4}$ " from out to out and reinforced with fifty-six 0.6 in. diameter low-relaxation strands. Twenty of these strands were draped with hold-down points at 40 percent of the total span length. The required area of shear reinforcement per foot at each section analyzed is summarized in Table 5-3 for both 60 ksi and 75 ksi design yield strength. The shear requirement that controls the minimum required area of shear reinforcement per foot at each section, excluding the maximum spacing requirement, is also displayed in Table 5-3.

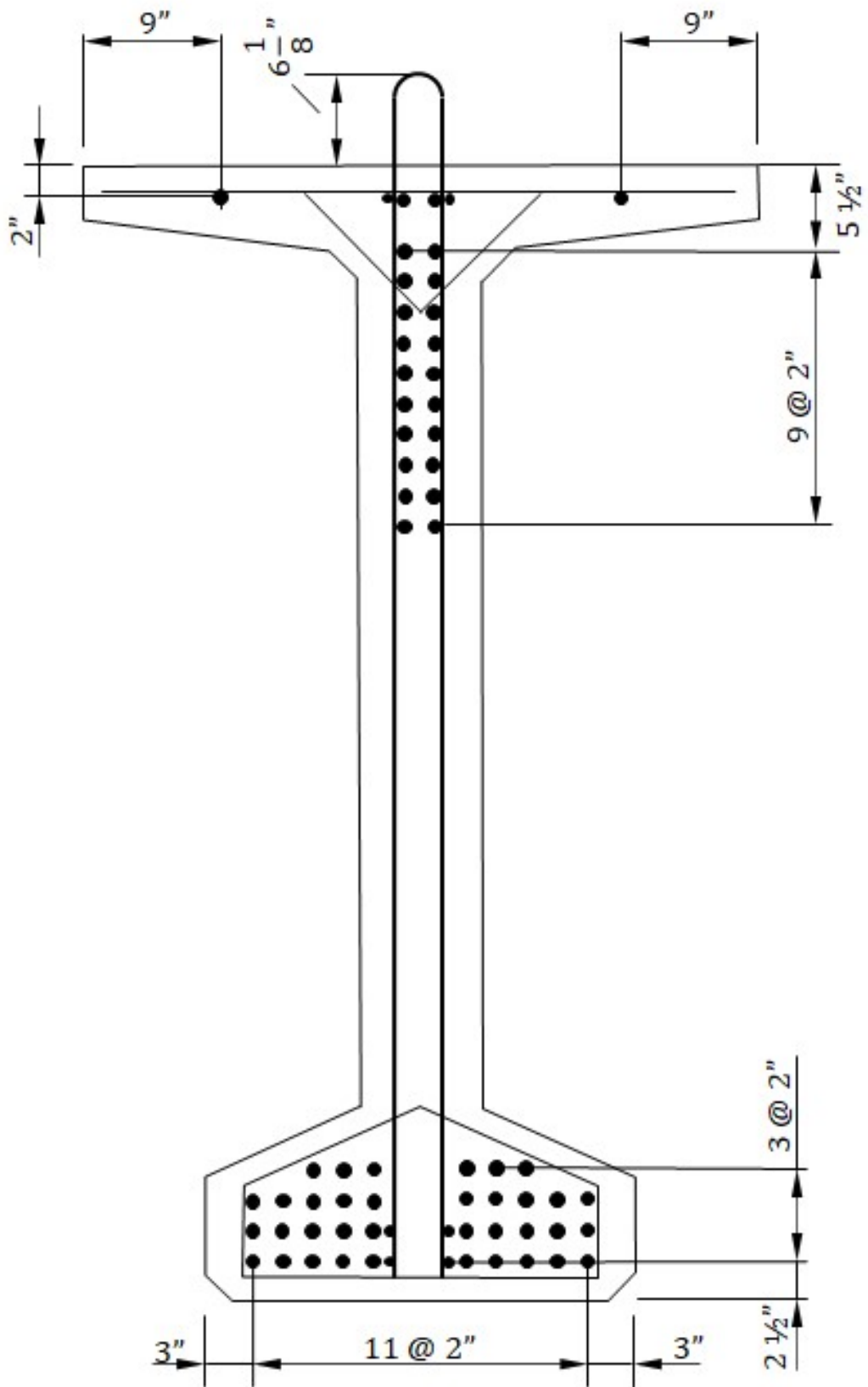

Figure 5-1 End cross section of BT-74 modified section

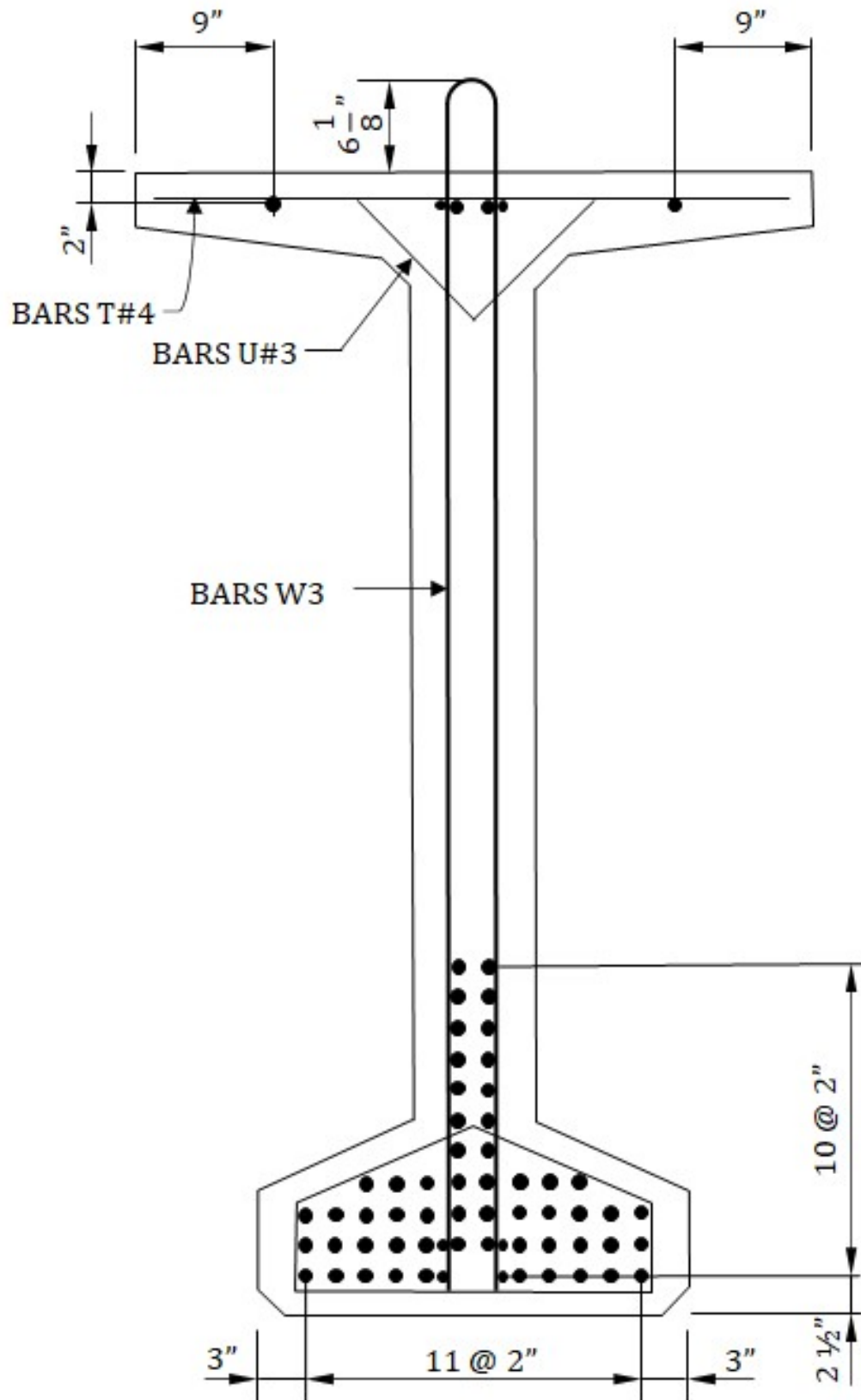

Figure 5-2 BT-74 modified cross section at the hold down points

Table 5-3 Shear design requirements for modified BT-74 girder

<i>BT-74 Modified Section Girder</i>							
			ALDOT		AASHTO		
<i>Location</i>	Distance from End (ft)	A_v/s (in ² /ft)	Size	Spacing (in.)	Size	Spacing (in.)	Controlled by
<i>Bearing</i>	0.71	AZ Splitting	#7	4	D60*	4	AZ Splitting
<i>Transfer</i>	3	0.138	#5	4	D20	24	Min Vertical Shear
<i>Critical</i>	6.7	0.138	#5	8	D20	24	Min Vertical Shear
<i>0.1L</i>	16.66	0.138	#5	12	D20	24	Min Vertical Shear
<i>0.2L</i>	33.31	0.138	#5	18	D20	24	Min Vertical Shear
<i>0.3L</i>	49.97	0.138	#5	18	D20	24	Min Vertical Shear
<i>0.4L</i>	66.63	0.138	#5	18	D20	24	Min Vertical Shear
<i>0.5L</i>	83.28	0.138	#5	18	D20	24	Min Vertical Shear
<i>75 ksi Design Yield Strength</i>							
<i>Location</i>	Distance from End (ft)	A_v/s (in ² /ft)	Size	Spacing (in.)	Size	Spacing (in.)	Controlled by
<i>Bearing</i>	0.71	AZ Splitting	#7	4	D60*	4	AZ Splitting
<i>Transfer</i>	3	0.113	#5	4	D16	24	Min Vertical Shear
<i>Critical</i>	6.7	0.111	#5	8	D16	24	Min Vertical Shear
<i>0.1L</i>	16.66	0.111	#5	12	D16	24	Min Vertical Shear
<i>0.2L</i>	33.31	0.111	#5	18	D16	24	Min Vertical Shear
<i>0.3L</i>	49.97	0.111	#5	18	D16	24	Min Vertical Shear
<i>0.4L</i>	66.63	0.111	#5	18	D16	24	Min Vertical Shear
<i>0.5L</i>	83.28	0.111	#5	18	D16	24	Min Vertical Shear

Note: "AZ Splitting" indicates that the transverse reinforcement is controlled by anchorage zone reinforcement requirements (AASHTO 5.9.4.4.1).

*A D60 is an atypical wire size and represents an equivalent 0.60 in² area

The modified BT-74 beam's required shear reinforcement area per foot is mainly controlled by the minimum vertical shear reinforcement. This requirement is satisfied by U-stirrups spaced at the maximum spacing requirement of 24 in. even for No. 4 equivalent (D20) WWR for both 60 ksi and 75 ksi design yield stress. In line with ALDOT specifications, spacing is kept at 4 in. for a length equal to a girder depth from the end, and the maximum spacing is limited to 18 inches. While AASHTO permits transitioning directly from 4 in. spacing to the maximum spacing, ALDOT uses a length of about 10 ft. of 8 in. spacings and then 12 in. spacings as a transition between the 4 in. spacings required at the girder end to the maximum spacing. Figure 5-3 shows this modified BT-74 beam designed in accordance with ALDOT spacing specifications for WWR sheets using No. 5 (D31) and No. 4 (D20) equivalent wire sizes and design yield stress of 60 ksi and 75 ksi. Figure 5-4 shows this modified BT-74 beam as drawn by ALDOT and as designed following only AASHTO requirements for WWR sheets using No. 5 (D31) and No. 4 (D20) equivalent wire sizes and design yield stress of 60 ksi and 75 ksi. Since most spacings are at the maximum spacing requirement, the design yield stress increase to 75 ksi was taken advantage of as a reduction in wire size rather than a potential increase in spacing.

AL4G75	Satisfies ALDOT spacing requirements with grade 75 wire that has an equivalent yield force to a grade 60 #4 bar
AL4G60	Satisfies ALDOT spacing requirements with wire that has an equivalent area of a #4 bar
AL5G75	Satisfies ALDOT spacing requirements with grade 75 Wire that has an equivalent yield force to a grade 60 #5 bar
AL5G60	Satisfies all ALDOT requirements with wire that has an equivalent area of a #5 bar
DRAW	As drawn by ALDOT

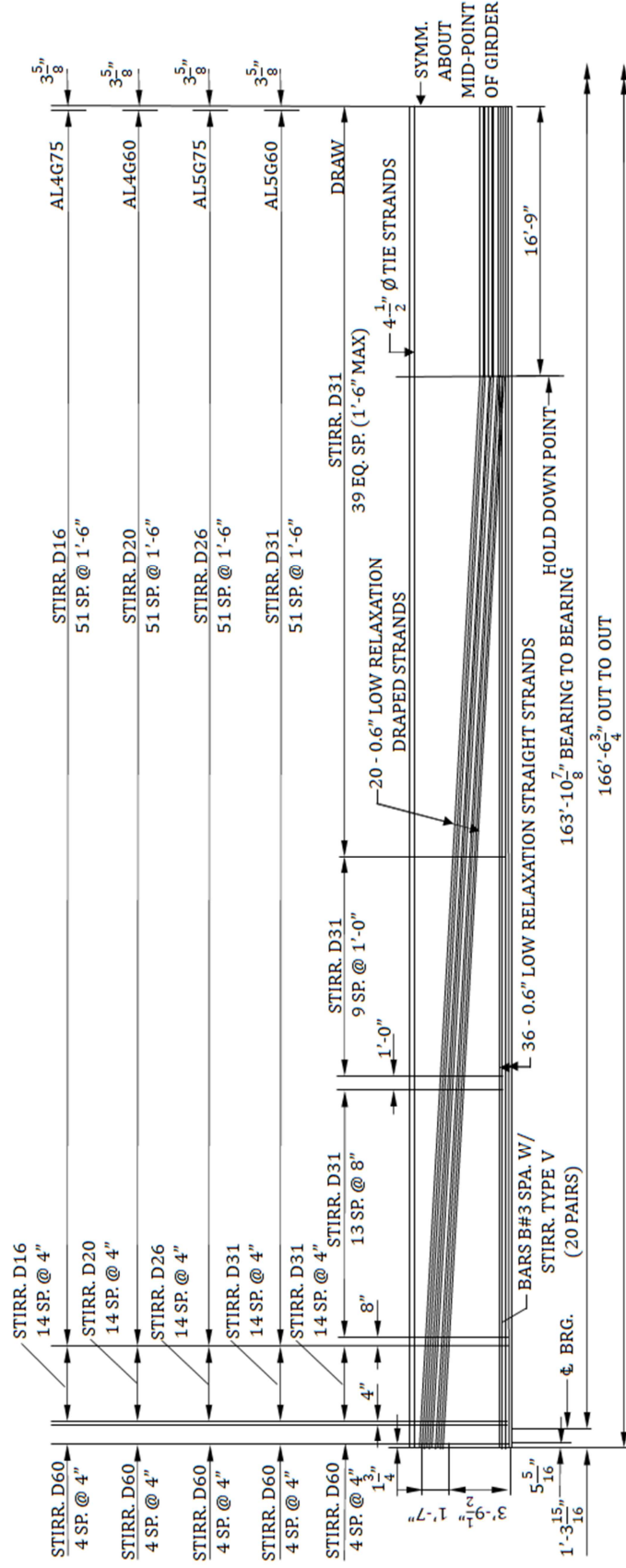

Figure 5-3 Modified BT-74 potential stirrup spacing configurations that meet ALDOT spacing requirements

4G75	Satisfies all AASHTO requirements with grade 75 wire that has an equivalent yield force to a grade 60 #4 bar
4G60	Satisfies all AASHTO requirements with wire that has an equivalent area of a #4 bar
5G75	Satisfies all AASHTO requirements with grade 75 Wire that has an equivalent yield force to a grade 60 #5 bar
5G60	Satisfies all AASHTO requirements with wire that has an equivalent area of a #5 bar
DRAW	As drawn by ALDOT

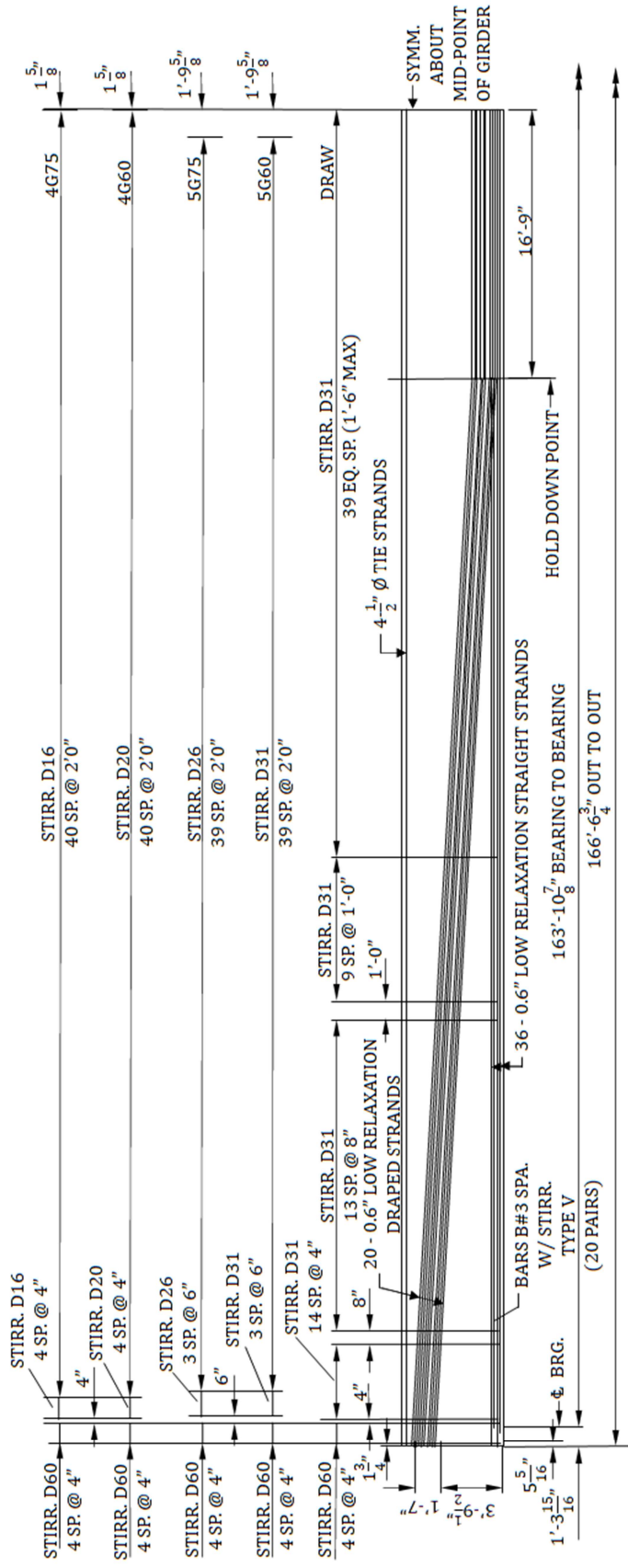

Figure 5-4 Modified BT-74 potential stirrup spacing configurations that meet AASHTO requirements

The stirrups provided near the bearing are controlled by the anchorage zone reinforcement requirement. Due to the large number of prestressing strands that are developed at the end of this girder, the anchorage zone stirrups for U-stirrups must be No. 7 bar or equivalent steel area (0.60 in^2)—a D60 wire size. Using 75 ksi design yield stress generates no benefit toward satisfying the anchorage zone reinforcement requirement (relative to 60 ksi). WWR is not commonly produced for wire sizes greater than D45 (Wire Reinforcement Institute 2003). Therefore, to meet the 0.60 in^2 area requirement, standard No. 7 reinforcing bars could be used, or a No. 5 bar can be tied to each D31 wire in a prefabricated WWR sheet such that the vertical wires and bars are effectively bundled, as shown in Figure 5-5. There are very few of these large bars at the very end of the girder, so this added complexity has a small impact on placement time or cost. This practice was presently being used at the Gulf Coast Prestress Partners plant toured.

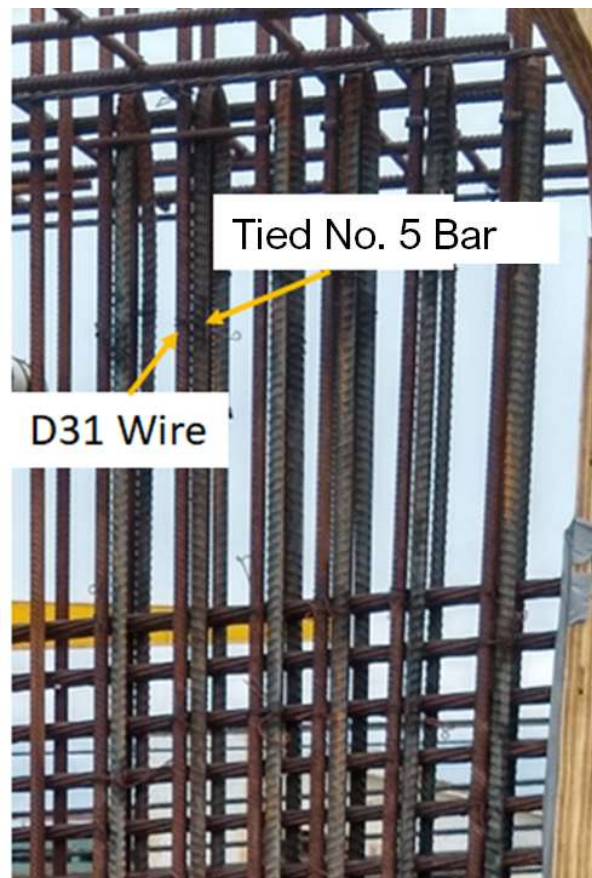

Figure 5-5 Reinforcing bars tied to WWR stirrup sheet to achieve a larger equivalent stirrup size

The ALDOT 4 in. spacing requirement in the end region provides the required shear strength for all possible stirrup sizes. The AASHTO-only girders show that spacings at 6 in. are functional for No. 5 equivalent bars (D31 wires) and 4 in. for the No. 4 equivalent bars (D20 wires). These spacings only are required through the end of the transfer length of the prestressing steel, where the shear reinforcement requirement falls because the added vertical prestressing force component increases the shear strength to only require stirrups at the AASHTO maximum spacing of 24 inches. Away from the end of the girder, the shear demand can be met with No. 4 equivalent bars (D20 wires) and larger at 24 inches. The ALDOT requirement limiting the maximum spacing to 18 in. means the stirrup patterns following ALDOT requirements provide an additional pair of stirrup legs relative to AASHTO every 6 feet. Since this maximum spacing covers the vast majority of the length for this beam, the stirrup patterns following only AASHTO requirements provide about 30 percent fewer stirrups compared to their ALDOT counterpart. Since the D16 stirrups and D20 stirrups follow the same stirrup spacings as the D31 and D26 for ALDOT patterns and only add one additional stirrup for the AASHTO patterns, it seems more efficient to use the smaller wire sizes for this girder.

The BT-74 modified section was fitted with the standardized sheets described in Table 5-2. The sheet layout for the ALDOT variations shown in Figure 5-3 are shown in Table 5-4 and the sheet layout for the AASHTO variations shown in Figure 5-4 are shown in Table 5-5.

Table 5-4 Modified BT-74 stirrup gross quantities for ALDOT design variations

<i>Modified BT-74 ALDOT Variations</i>				
<i>Variation</i>	Stirrup weight (lb)	2-legged stirrups (No.)	Installed Elements (No.)	Sheets (No.)
<i>DRAW</i>	2405	164	328	N/A
<i>AL5G60</i>	2373	161	34	14
<i>AL5G75</i>	2071	161	34	14
<i>AL4G60</i>	1638	161	34	14
<i>AL4G75</i>	1350	161	34	14

Table 5-5 Modified BT-74 stirrup sheet gross quantities for AASHTO design variations

<i>Modified BT-74 AASHTO LRFD Variations</i>				
<i>Variation</i>	Stirrup weight (lb)	2-legged stirrups (No.)	Installed Elements (No.)	Sheets (No.)
5G60	1665	110	30	10
5G75	1477	110	30	10
4G60	1182	110	30	10
4G75	985	110	30	10

Table 5-5 clearly shows a substantial (90 percent) reduction in the number of installed elements for the stirrups when switching from the typical reinforcing bar stirrups present in the ALDOT drawing to WWR stirrups, even when a similar number of total stirrups are being provided. This major reduction is due to a combination of eleven to sixteen stirrups being provided per WWR sheet and each reinforcing bar 2-legged stirrup comprising two separate bars. The WWR's additional elements, excluding sheets, come from additional reinforcing bars that are expected to be tied to the sheets in the anchorage zone. It was assumed that two separate reinforcing bars would be provided per 2-legged stirrup where required. The effects of using smaller sized stirrups are shown in stirrup weight, where the 4G75 variation provides the same number of stirrups with less steel weight. This steel weight includes only the weight of the primary shear reinforcement and does not include steel such as cross-wires or hook lengths for reinforcing bars.

The primary differences between the ALDOT and AASHTO variations are (a) the AASHTO variations employ standard sheets with 24 in. spacings instead of ALDOT- maximum 18 in. spacings and (b) the ALDOT requirement for 4 in. spacings at the ends of girders extends farther than the standard length of a single 4 in. spaced sheet and thus requires two 4 in. spaced sheets instead of one.

5.4 AASHTO TYPE III SECTION, 89 FT LONG GIRDER

A typical AASHTO Type III girder cross section with a length of 89'-2 1/2" out to out was designed. The cross section of the girder, showing the location of the strands and recommended WWR stirrup shapes for both the end of the girder and at the hold-down

points, is shown in Figures 5-6 and 5-7. The girder is reinforced with forty-two 0.5 in. diameter low-relaxation strands. Thirty-four of these strands were straight, and eight were draped from the hold-down point that is located 10 feet from midspan. The required area of shear reinforcement per foot at each section analyzed is summarized in Table 5-6 for both 60 ksi and 75 ksi design yield strength. The shear requirement that controls the minimum required area of shear reinforcement per foot at each section, excluding the maximum spacing requirement, is also displayed in Table 5-6.

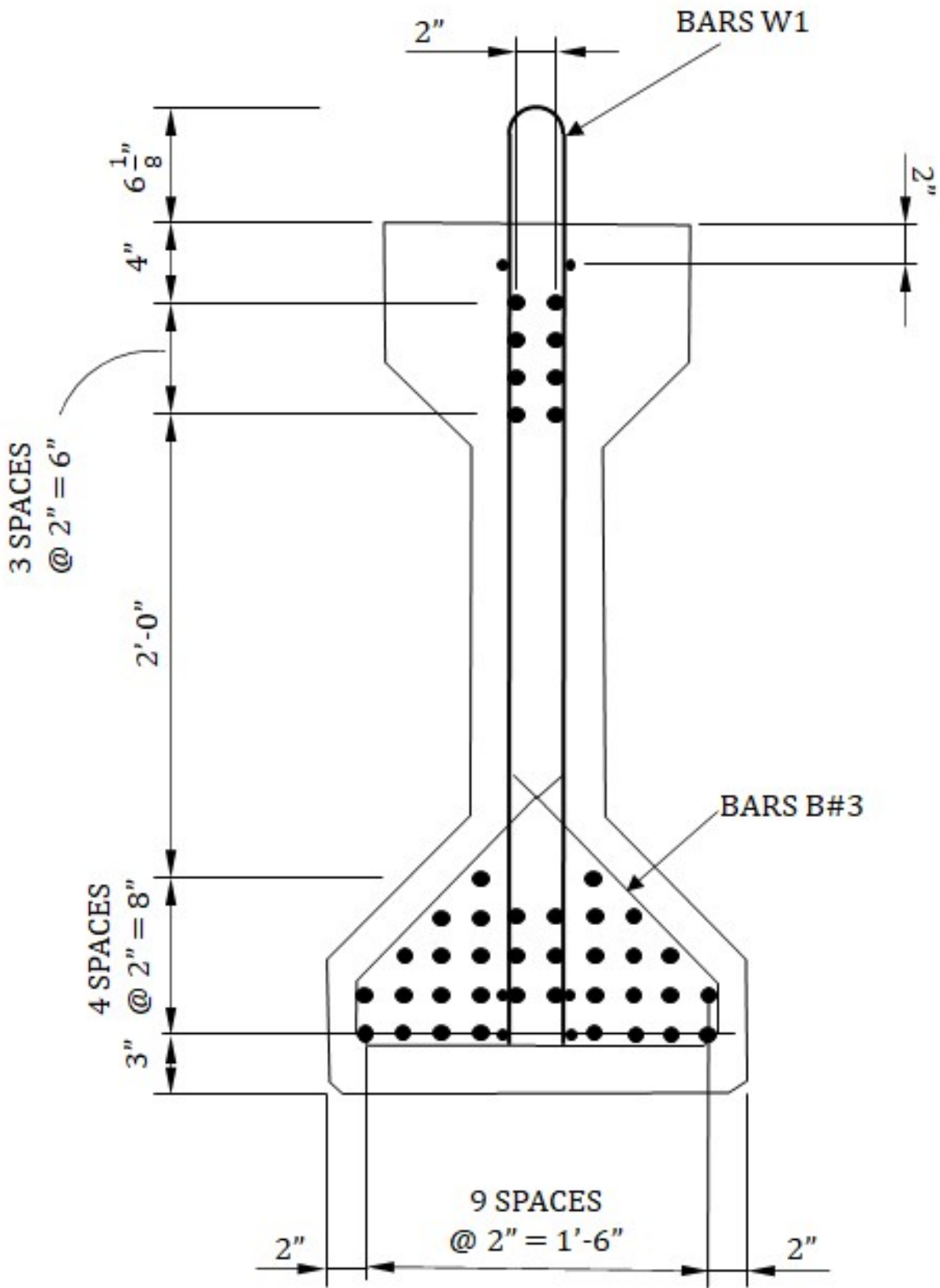

Figure 5-6 End cross section of AASHTO Type III girder

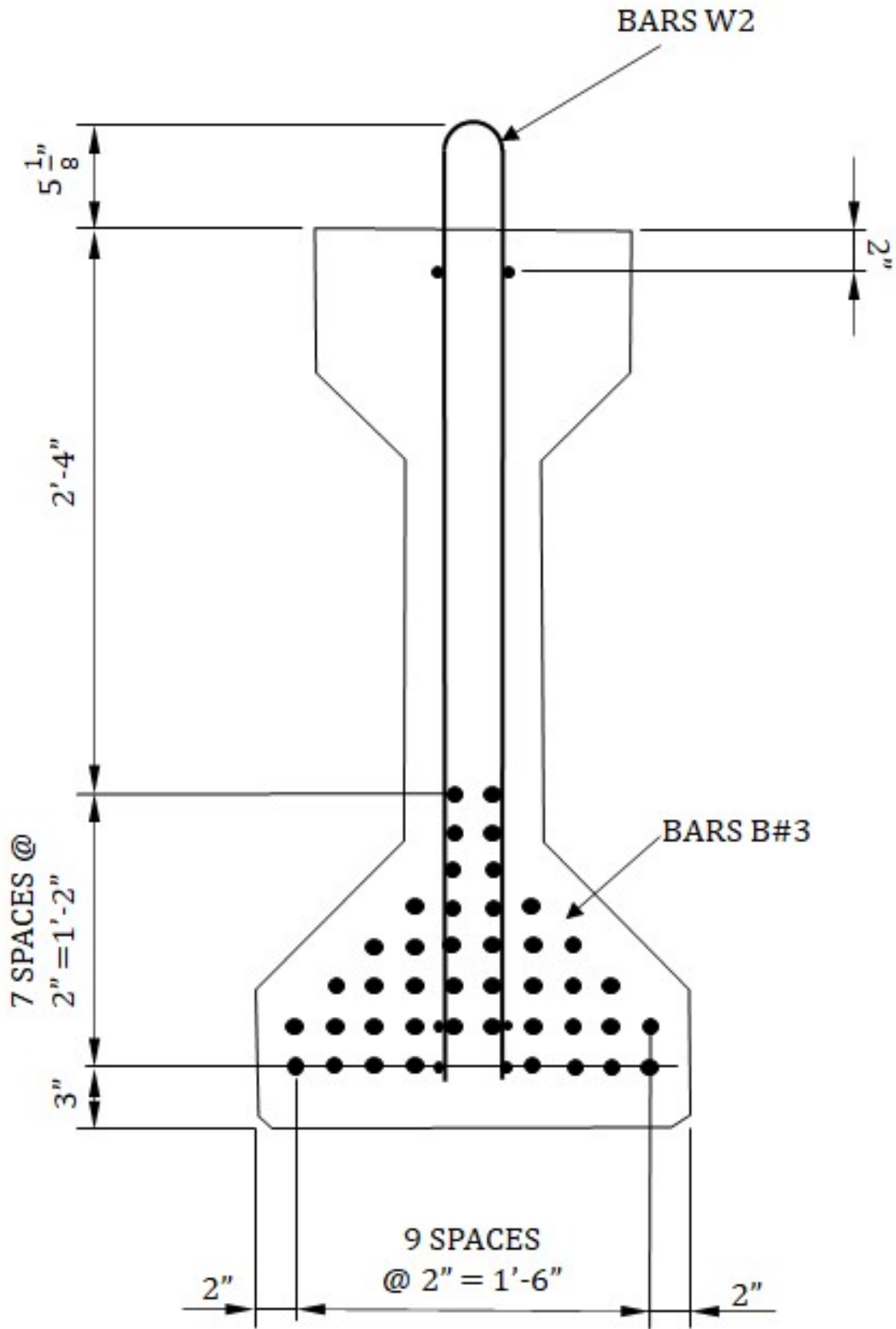

Figure 5-7 Hold down point cross section of AASHTO Type III girder

Table 5-6 Shear design requirements for AASHTO Type III girder

<i>AASHTO TYPE III (Regular 90)</i>							
<i>Location</i>	Distance from End (ft)	A_v/s (in ² /ft)	ALDOT		AASHTO		
			Size	Spacing (in.)	Size	Spacing (in.)	Controlled by
<i>Bearing</i>	1.0	AZ Splitting	#6	4	D45	4	AZ Splitting
<i>Transfer</i>	2.5	0.160	#5	4	D20	24	Min Interface Shear
<i>Critical</i>	3.28	0.160	#5	4	D20	24	Min Interface Shear
<i>0.1L</i>	9.0	0.160	#5	12	D20	24	Vertical Shear
<i>0.2L</i>	18.0	0.160	#5	12	D20	24	Min Vertical Shear
<i>0.3L</i>	27.0	0.125	#5	12	D20	24	Min Vertical Shear
<i>0.4L</i>	36.0	0.125	#5	12	D20	24	Min Vertical Shear
<i>0.5L</i>	45.0	0.125	#5	12	D20	24	Min Vertical Shear
<i>75 ksi Design Yield Strength</i>							
<i>Location</i>	Distance from End (ft)	A_v/s (in ² /ft)	Size	Spacing (in.)	Size	Spacing (in.)	Controlled by
<i>Bearing</i>	1.0	AZ Splitting	#6	4	D45	4	AZ Splitting
<i>Transfer</i>	2.5	0.160	#5	4	D16	24	Min Interface Shear
<i>Critical</i>	3.28	0.160	#5	4	D16	24	Min Interface Shear
<i>0.1L</i>	9.0	0.160	#5	12	D16	24	Vertical Shear
<i>0.2L</i>	18.0	0.160	#5	12	D16	24	Min Vertical Shear
<i>0.3L</i>	27.0	0.100	#5	12	D16	24	Min Vertical Shear
<i>0.4L</i>	36.0	0.100	#5	12	D16	24	Min Vertical Shear
<i>0.5L</i>	45.0	0.100	#5	12	D16	24	Min Vertical Shear

Note: "AZ Splitting" indicates that the transverse reinforcement is controlled by anchorage zone reinforcement requirements (AASHTO 5.9.4.4.1).

The required shear reinforcement area per foot is controlled by the minimum interface shear requirement and the minimum vertical shear requirement. The interface shear requirement is critical for this girder due to the much smaller contact area with the deck slab than is present with a BT girder section. This smaller area increases the minimum interface shear reinforcement requirement above that of the minimum vertical shear requirement. The minimum vertical shear requirement begins to control towards the middle of the beam because the shear demand drops to the point where the minimum vertical shear reinforcement provides enough capacity to cover a 33 percent increase in the shear demand. It should be noted that the increase in design yield strength does not affect interface shear reinforcement requirements because AASHTO does not yet allow use of a yield strength above 60 ksi for those calculations. However, like the modified BT-74, the AASHTO Type III girder meets all shear requirements beyond the transfer length by U-stirrups spaced at the maximum spacing of 24 in. even for wire sizes as small as D16.

Figure 5-8 shows the AASHTO Type III girder designed in accordance with ALDOT spacing specifications with WWR sheets using No. 5 and 4 equivalent (D31 and D20) wire sizes with design yield strengths of 60 ksi and 75 ksi, as well as an example ALDOT design. Figure 5-9 shows this AASHTO Type III girder following only AASHTO requirements for WWR sheets with the same variations as Figure 5-8.

AL4G75	Satisfies ALDOT spacing requirements with grade 75 wire that has an equivalent yield force to a grade 60 #4 bar
AL4G60	Satisfies ALDOT spacing requirements with wire that has an equivalent area of a #4 bar
AL5G75	Satisfies ALDOT spacing requirements with grade 75 Wire that has an equivalent yield force to a grade 60 #5 bar
AL5G60	Satisfies all ALDOT requirements with wire that has an equivalent area of a #5 bar
DRAW	As drawn by ALDOT

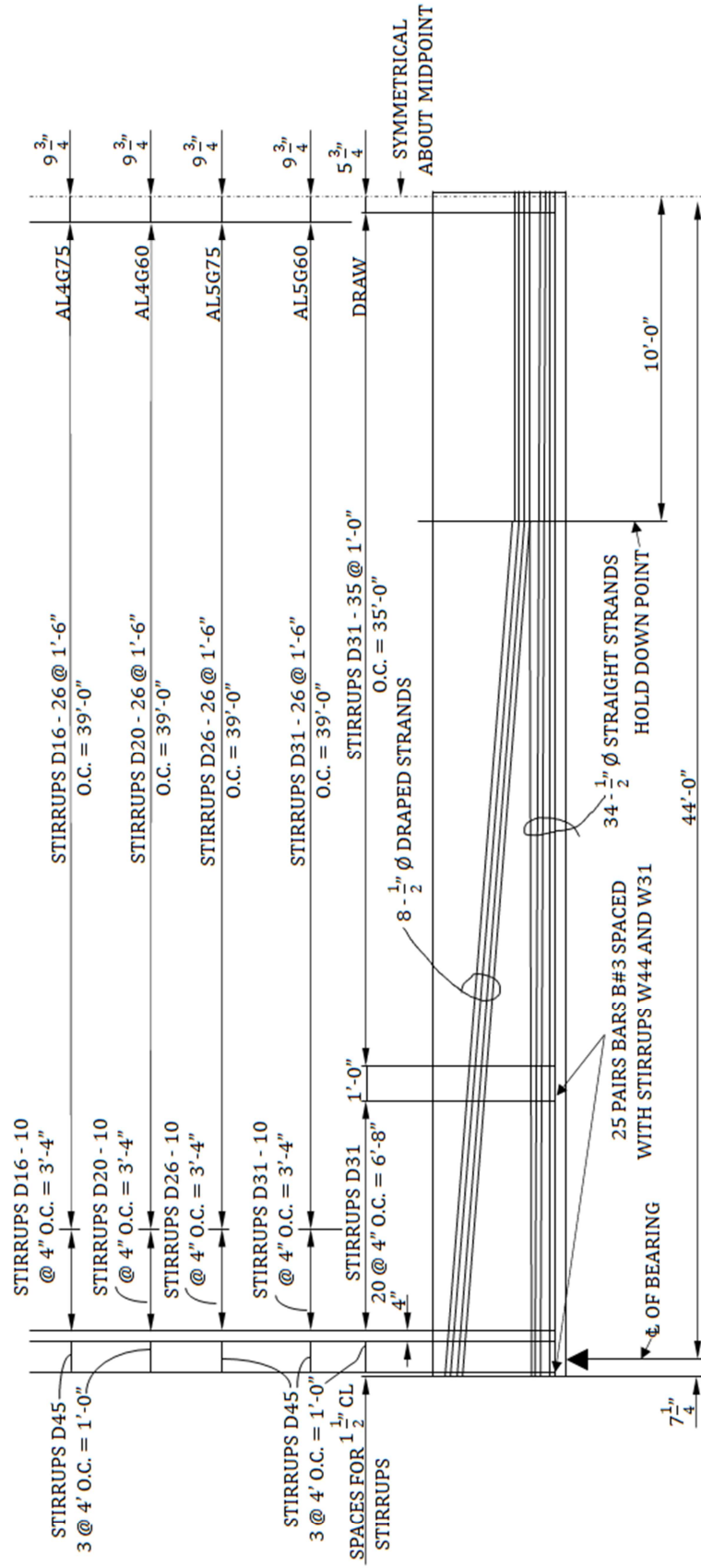

Figure 5-8 AASHTO Type III girder potential stirrup spacing configurations that meet ALDOT spacing requirements

4G75	Satisfies all AASHTO requirements with grade 75 wire that has an equivalent yield force to a grade 60 #4 bar
4G60	Satisfies all AASHTO requirements with wire that has an equivalent area of a #4 bar
5G75	Satisfies all AASHTO requirements with grade 75 Wire that has an equivalent yield force to a grade 60 #5 bar
5G60	Satisfies all AASHTO requirements with wire that has an equivalent area of a #5 bar
DRAW	As drawn by ALDOT

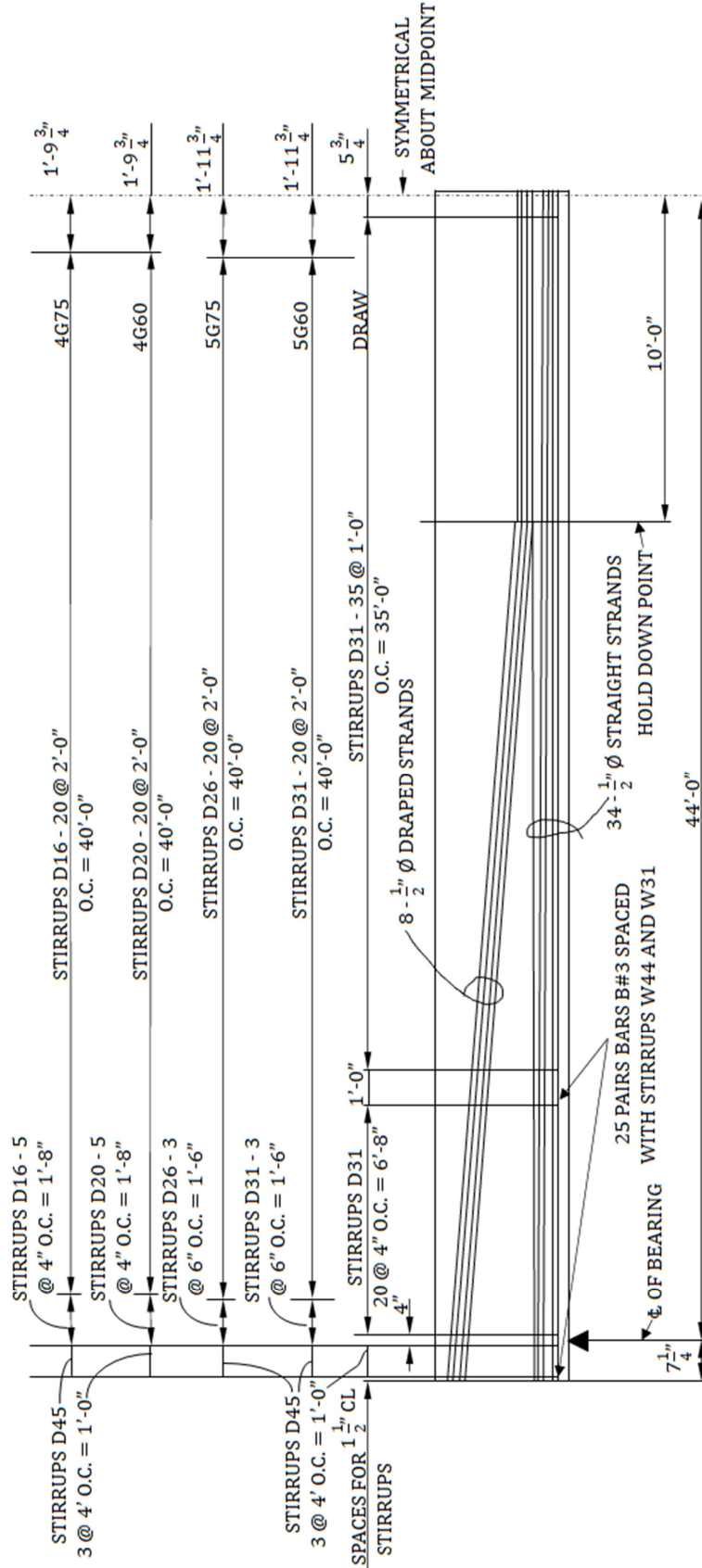

Figure 5-9 AASHTO Type III girder potential stirrup spacing configurations that meet AASHTO requirements

The stirrups at the bearing are controlled by the anchorage zone requirement. D45 wire is a sufficient size for this reinforcement, but if availability is a problem, then No. 6 reinforcing bars may be used instead with little difference in placement time due to only six stirrups, three at each end, needing this stirrup size. This anchorage zone reinforcement is the same for all the stirrup layouts. After the anchorage zone reinforcement, the ALDOT drawing has No. 5 stirrups at 4 in. for about two girder depths and then uses 12 in. spacing for the rest of the girder. ALDOT specifications only call for the 4 in. spacing to persist for one girder depth, as seen in other stirrup layouts in Figure 5-8. These layouts transition directly into the maximum spacing of 18 in. as allowed by ALDOT specifications once one girder depth is reached. The AASHTO layouts seen in Figure 5-9 use 6 in. spaces for the D31 and D26 stirrups and 4 in. spaces for the D20 and D16 stirrups to meet shear strength to the transfer length of the prestressing steel. After the transfer length is reached, all stirrup layouts go to the maximum spacing of 24 in. The ALDOT requirement limiting the maximum spacing to 18 in. means the stirrup patterns following ALDOT requirements provide an additional stirrup over AASHTO every 6 feet. Since this maximum spacing covers the vast majority of the length for this beam, the stirrup patterns following only AASHTO requirements provide about 30 percent fewer stirrups compared to their ALDOT counterpart. For the ALDOT patterns, all the stirrup layouts follow the same spacings. For the AASHTO patterns, four additional stirrups are required for the D20 and D16 stirrup layouts compared to the D31 and D26 stirrup layouts. Due to the small number of additional stirrups, the smaller wires seem best for use in this girder.

The AASHTO Type III section was fitted with the standardized sheets described in Table 5-2. The sheet layout for the ALDOT variations shown in Figure 5-8 are shown in Table 5-7 and the sheet layout for the AASHTO variations shown in Figure 5-9 are shown in Table 5-8.

Table 5-7 AASHTO Type III section stirrup gross quantities for ALDOT design variations

<i>AASHTO Type III ALDOT Variations</i>				
<i>Variation</i>	Stirrup weight (lb)	2-legged stirrups (No.)	Installed Elements (No.)	Sheets (No.)
<i>DRAW</i>	771	122	244	N/A
<i>AL5G60</i>	566	84	24	8
<i>AL5G75</i>	482	84	24	8
<i>AL4G60</i>	382	84	24	8
<i>AL4G75</i>	316	84	24	8

Table 5-8 AASHTO Type III section stirrup gross quantities for AASHTO design variations

<i>AASHTO Type III AASHTO Variations</i>				
<i>Variation</i>	Stirrup weight (lb)	2-legged stirrups (No.)	Installed Elements (No.)	Sheets (No.)
<i>5G60</i>	486	71	23	6
<i>5G75</i>	415	71	23	6
<i>4G60</i>	331	71	23	6
<i>4G75</i>	274	71	23	6

Table 5-7 clearly shows a substantial (90 percent) reduction in the number of installed elements for the stirrups when switching from the typical reinforcing bar stirrups present in the original drawing to WWR stirrups even when a similar number of stirrups are being provided. The 4G75 variation meets all requirements by providing the same number of stirrups with less steel weight. The difference between the ALDOT and AASHTO variations is the AASHTO variations could use standard sheets with 24 in. spacings instead of 18 in. spacings. The longer length of the 24 in. spacing sheet leads to the AASHTO variations using two less sheets.

5.5 BT-72 SECTION, 134 FT LONG GIRDER

A typical BT-72 girder cross section with a length of 134'-2 1/2" out to out was designed. The girder is reinforced with forty 0.6 in. diameter strands with thirty-two strands straight and eight strands draped from the hold-down point located 13 feet away from midspan. The cross section of the girder showing the location of the strands and the recommended WWR stirrup shape are shown in Figures 5-10 and 5-11 for the end

and hold-down points of the girder. The required area of shear reinforcement per foot at each section analyzed is summarized in Table 5-9 for both 60 ksi and 75 ksi design yield strength. The shear requirement that controls the required area of shear reinforcement per foot at each section, excluding the maximum spacing, is also displayed in Table 5-9.

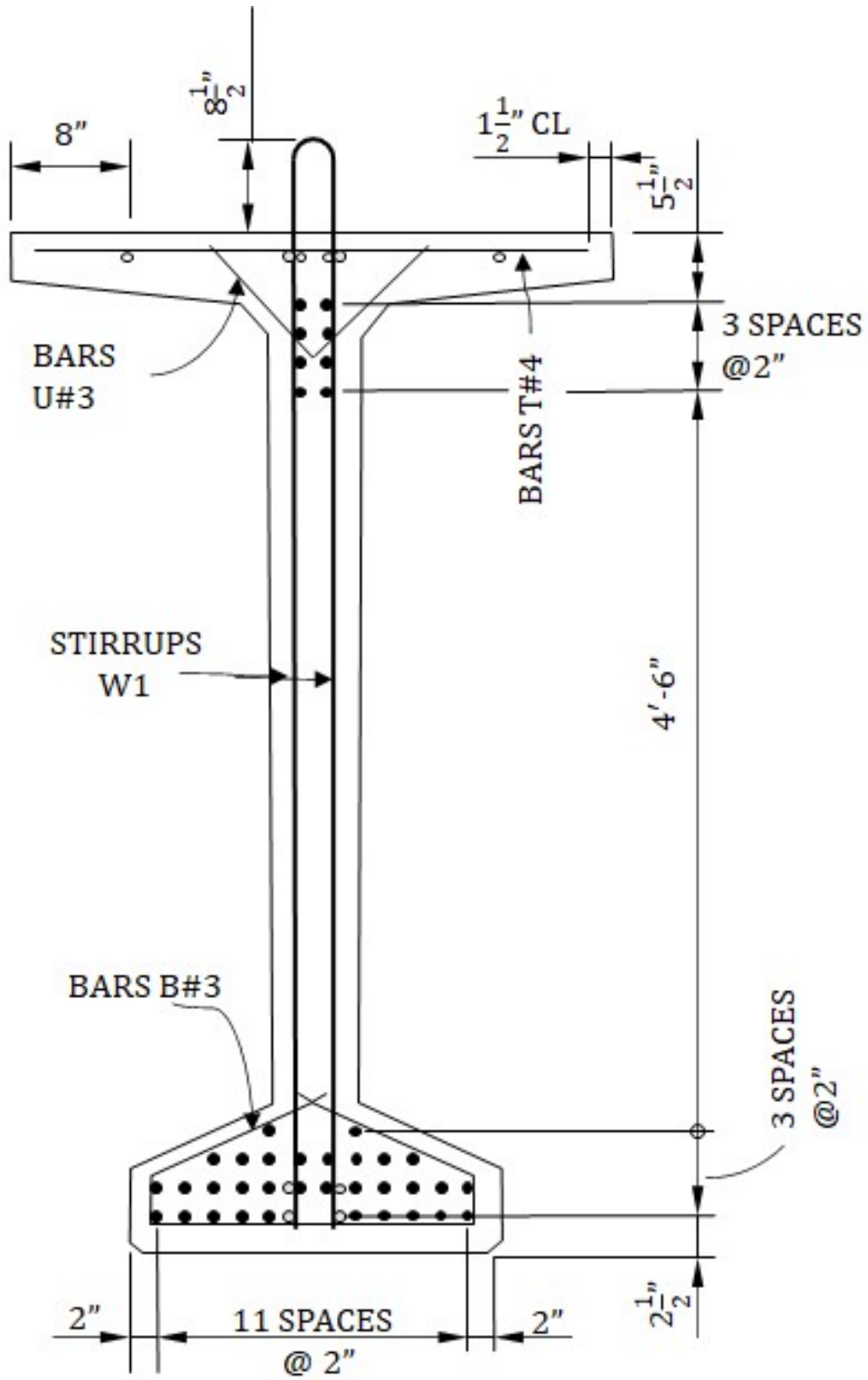

Figure 5-10 End cross section of BT-72 girder

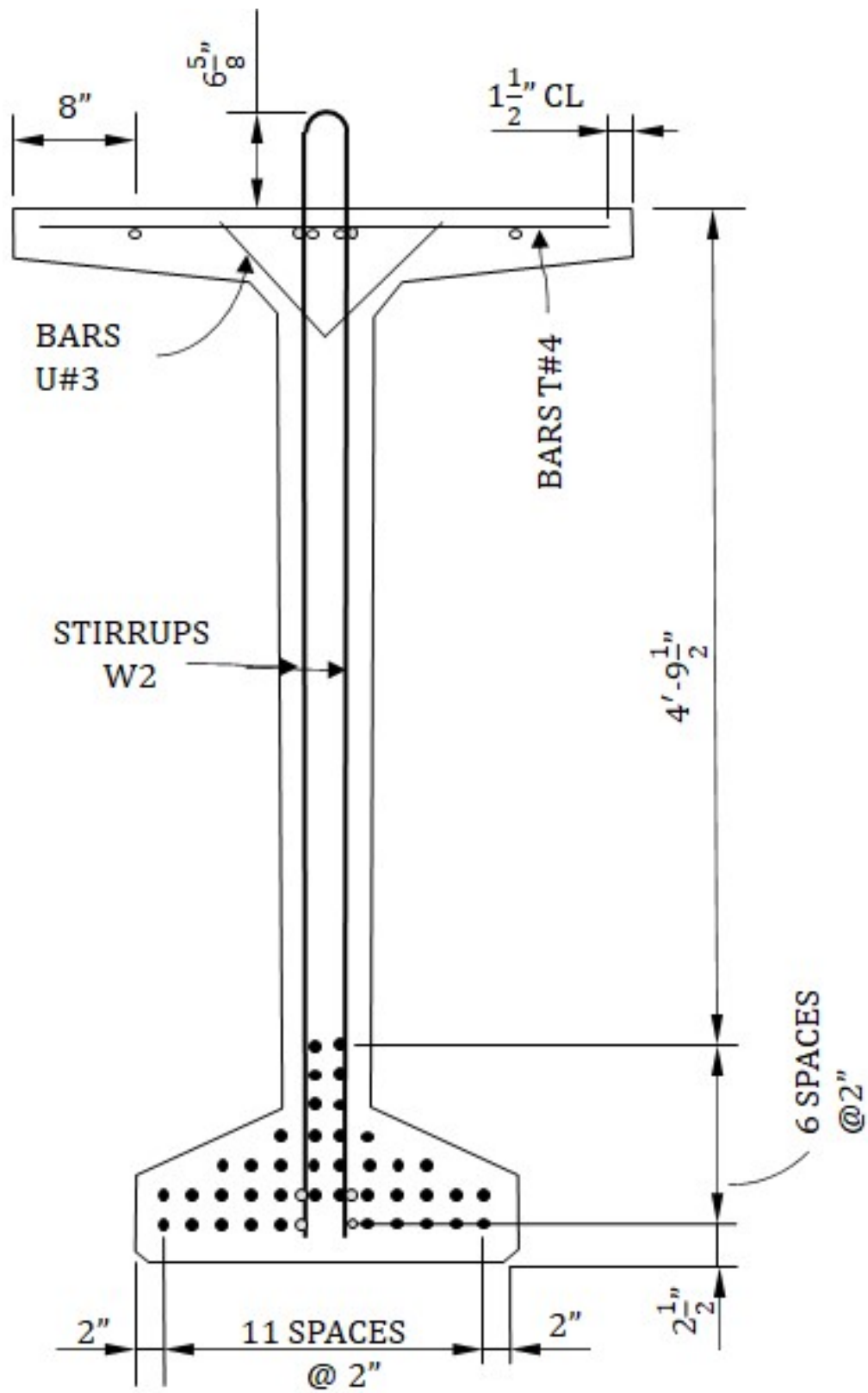

Figure 5-11 Hold down point cross section of BT-72 girder

Table 5-9 Shear design requirements for BT-72 girder

<i>BT-72 (Regular Beam 135)</i>							
<i>Location</i>	Distance from End (ft)	<i>A_v/s (in²/ft)</i>	ALDOT		AASHTO		
			Size	Spacing (in.)	Size	Spacing (in.)	Controlled by
<i>Bearing</i>	0.60	AZ Splitting	#6	4	D45	4	AZ Splitting
<i>Transfer</i>	3	0.117	#5	4	D20	24	Vertical Shear Strength
<i>Critical</i>	4.03	0.111	#5	4	D20	24	Vertical Shear Strength
<i>0.1L</i>	13.42	0.107	#5	8	D20	24	Min Vertical Shear
<i>0.2L</i>	26.84	0.107	#5	18	D20	24	Min Vertical Shear
<i>0.3L</i>	40.26	0.107	#5	18	D20	24	Min Vertical Shear
<i>0.4L</i>	53.68	0.107	#5	18	D20	24	Min Vertical Shear
<i>0.5L</i>	67.1	0.107	#5	18	D20	24	Min Vertical Shear
<i>75 ksi Design Yield Strength</i>							
<i>Location</i>	Distance from End (ft)	<i>A_v/s (in²/ft)</i>	Size	Spacing (in.)	Size	Spacing (in.)	Controlled by
<i>Bearing</i>	0.60	AZ Splitting	#6	4	D45	4	AZ Splitting
<i>Transfer</i>	3	0.094	#5	4	D16	24	Vertical Shear Strength
<i>Critical</i>	4.03	0.089	#5	4	D16	24	Vertical Shear Strength
<i>0.1L</i>	13.42	0.086	#5	8	D16	24	Min Vertical Shear
<i>0.2L</i>	26.84	0.086	#5	18	D16	24	Min Vertical Shear
<i>0.3L</i>	40.26	0.086	#5	18	D16	24	Min Vertical Shear
<i>0.4L</i>	53.68	0.086	#5	18	D16	24	Min Vertical Shear
<i>0.5L</i>	67.1	0.086	#5	18	D16	24	Min Vertical Shear

Note: "AZ Splitting" indicates that the transverse reinforcement is controlled by anchorage zone reinforcement requirements (AASHTO 5.9.4.4.1).

The BT-72 girder's required shear reinforcement area per foot is controlled by the vertical shear strength demand on the girder until the first tenth of the girder length is reached. For the middle 80 percent of the beam length, the minimum required vertical shear reinforcement controls. However, all vertical shear reinforcement requirements are satisfied by D20 wire and D16 wire at the maximum spacing of 24 in. once beyond the transfer length.

Figure 5-12 shows the BT-72 girder designed in accordance with ALDOT spacing specifications with WWR sheets using No. 5 and 4 equivalent (D31 and D20) wire sizes with design yield strengths of 60 ksi and 75 ksi, as well as a sample ALDOT design. Figure 5-13 shows this BT-72 following only AASHTO requirements for WWR sheets with the same variations as Figure 5-12.

4G75	Satisfies all AASHTO requirements with grade 75 wire that has an equivalent yield force to a grade 60 #4 bar
4G60	Satisfies all AASHTO requirements with wire that has an equivalent area of a #4 bar
5G75	Satisfies all AASHTO requirements with grade 75 Wire that has an equivalent yield force to a grade 60 #5 bar
5G60	Satisfies all AASHTO requirements with wire that has an equivalent area of a #5 bar
DRAW	As drawn by ALDOT

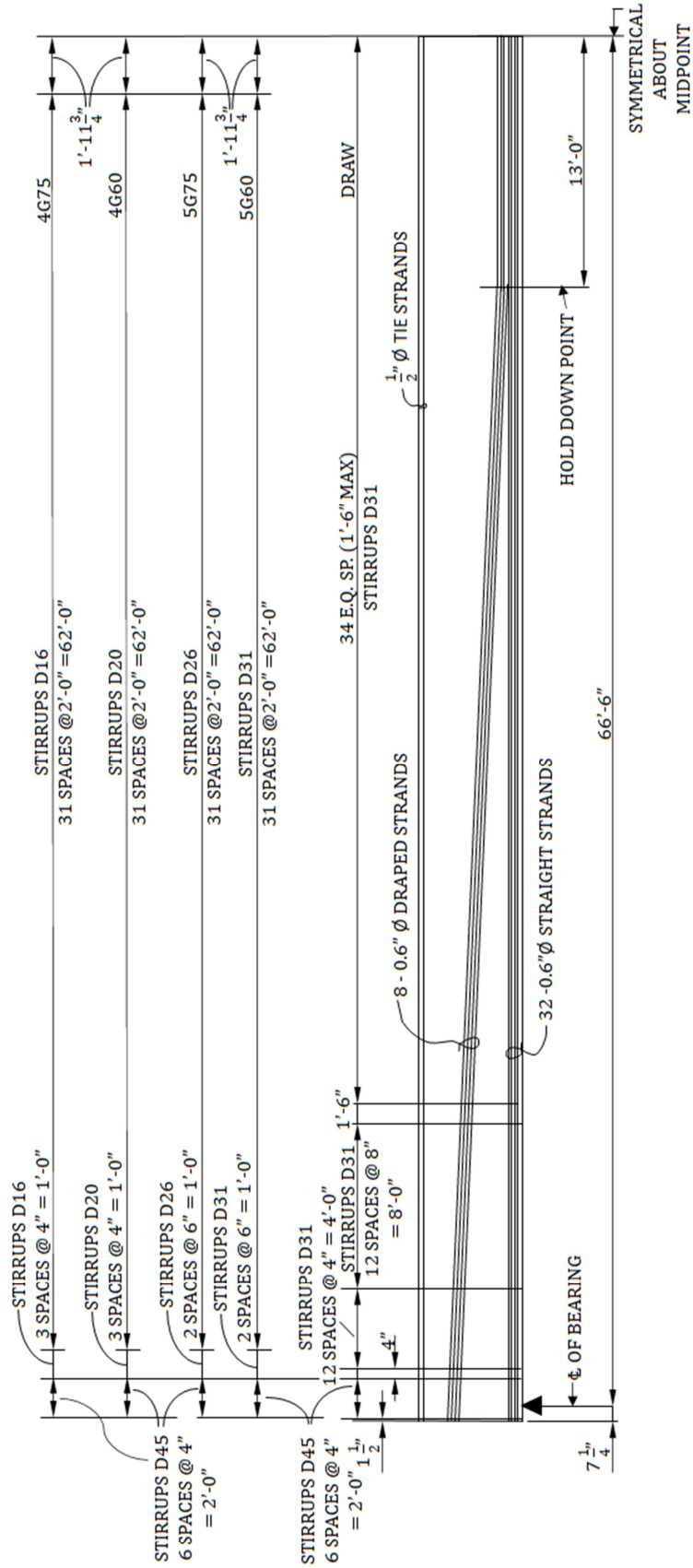

Figure 5-13 BT-72 girder potential stirrup spacing configurations that meet AASHTO requirements

Stirrups provided at the end for the anchorage zone requirement may be either D45 wire or No. 6 reinforcing bars. The low number of these bars means time savings for using wire are minimal, and the required stirrup size may affect wire availability. The anchorage zone reinforcement remains the same for all the stirrup layouts. After the anchorage zone reinforcement, the ALDOT drawing uses No. 7 bars at 4 in. spacing, then 4 feet of No. 5 bars at 4 in. spacing, then 8 feet of No. 5 bars at 8 in. spacing. The set of No. 5 bars at 4 in. spacings are to meet the ALDOT specification for 4 in. spaces for a girder depth. Therefore, these spacings are also seen in the other ALDOT drawings. The 8 in. spacing is a transition to the ALDOT maximum spacing of 18 in. Since such transitional spacings are not required by AASHTO or in the ALDOT specification, the other ALDOT designs go directly from the 4 in. spacings to the 18 in. maximum spacing. The AASHTO layouts use 6 in. spaces for the D31 and D26 stirrups and 4 in. spaces for the D20 and D16 stirrups between the anchorage zone reinforcement and the transfer length of the prestressing steel. After the transfer length is reached, all AASHTO stirrup layouts go to the maximum spacing of 24 in.

The ALDOT requirement limiting the maximum spacing to 18 in. means the stirrup patterns following ALDOT requirements provide an additional stirrup relative to AASHTO every 6 feet. Since this maximum spacing covers the vast majority of the length for this beam, the stirrup patterns following only AASHTO requirements provide about 30 percent fewer stirrups compared to their ALDOT counterparts. For the ALDOT patterns, all the stirrup layouts follow the same spacings. For the AASHTO patterns, two additional stirrups are required for the D20 and D16 stirrup layouts compared to the D31 and D26 stirrup layouts. Due to the small number of additional stirrups, the smaller wires seem best for use in this girder.

The BT-72 section was fitted with the standardized sheets described in Table 5-2. The sheet layout for the ALDOT variations shown in Figure 5-12 are shown in Table 5-10 and the sheet layout for the AASHTO variations shown in Figure 5-13 are shown in Table 5-11.

Table 5-10 BT-72 section stirrup gross quantities for ALDOT design variations

<i>BT-72 ALDOT Variations</i>				
<i>Variation</i>	Stirrup weight (lb)	2-legged stirrups (No.)	Installed Elements (No.)	Sheets (No.)
<i>DRAW</i>	1941	134	268	N/A
<i>AL5G60</i>	2123	139	41	12
<i>AL5G75</i>	1812	139	41	12
<i>AL4G60</i>	1439	139	41	12
<i>AL4G75</i>	1190	139	41	12

Table 5-11 BT-72 section stirrup gross quantities for AASHTO design variations

<i>BT-72 AASHTO Variations</i>				
<i>Variation</i>	Stirrup weight (lb)	2-legged stirrups (No.)	Installed Elements (No.)	Sheets (No.)
<i>5G60</i>	1485	93	37	8
<i>5G75</i>	1277	93	37	8
<i>4G60</i>	1027	93	37	8
<i>4G75</i>	860	93	37	8

Table 5-10 clearly shows a substantial (85 percent) reduction in the number of installed elements for the stirrups when switching from the typical reinforcing bar stirrups present in the original drawing to WWR stirrups even when a similar number of stirrups are being provided. The 4G75 variation meets all requirements by providing the same number of stirrups with less steel weight. The difference between the ALDOT and AASHTO variations is the AASHTO variations could use standard sheets with 24 in. spacings instead of 18 in. spacings. The longer length of the 24 in. spacing sheet leads to the AASHTO variations using less sheets. The ALDOT variations also require a second sheet of 4 in. spacings to meet ALDOT's requirement of 4 in. spacings for a girder depth at each end. Providing the full second 4 in. spaced sheet beyond where 4 in. spacings are required causes the ALDOT variations to provide more stirrups than the reinforcing bar drawing.

5.6 AASHTO TYPE I MODIFIED SECTION, 79 FT LONG GIRDER

An AASHTO Type I girder cross-section modified to be 30 in. deep, to have an 11 in. wide web, and to have a 26 in. wide bottom flange was designed for shear. The length of the girder is 79'-2 1/2" out to out. The girder is reinforced with forty-two 0.5 in. diameter strands, of which six were draped, and thirty-six were straight. The draped strands were draped at the hold-down points located 12 feet from the midspan on each side. Four of the straight strands are debonded at the end of the girder. Two of these strands become bonded 4 feet from the end, and the other two become bonded 8 feet from the end. These unbonded strands are marked with a square and a circle, respectively. The cross section of the girder showing the location of the strands and the recommended WWR stirrup shape are shown in Figures 5-14 and 5-15 for the end and hold-down points of the girder. The required area of shear reinforcement per foot at each section analyzed is summarized in Table 5-12 for both 60 ksi and 75 ksi design yield strength. The shear requirement that controls the required area of shear reinforcement per foot at each section, excluding the maximum spacing, is also displayed in Table 5-12.

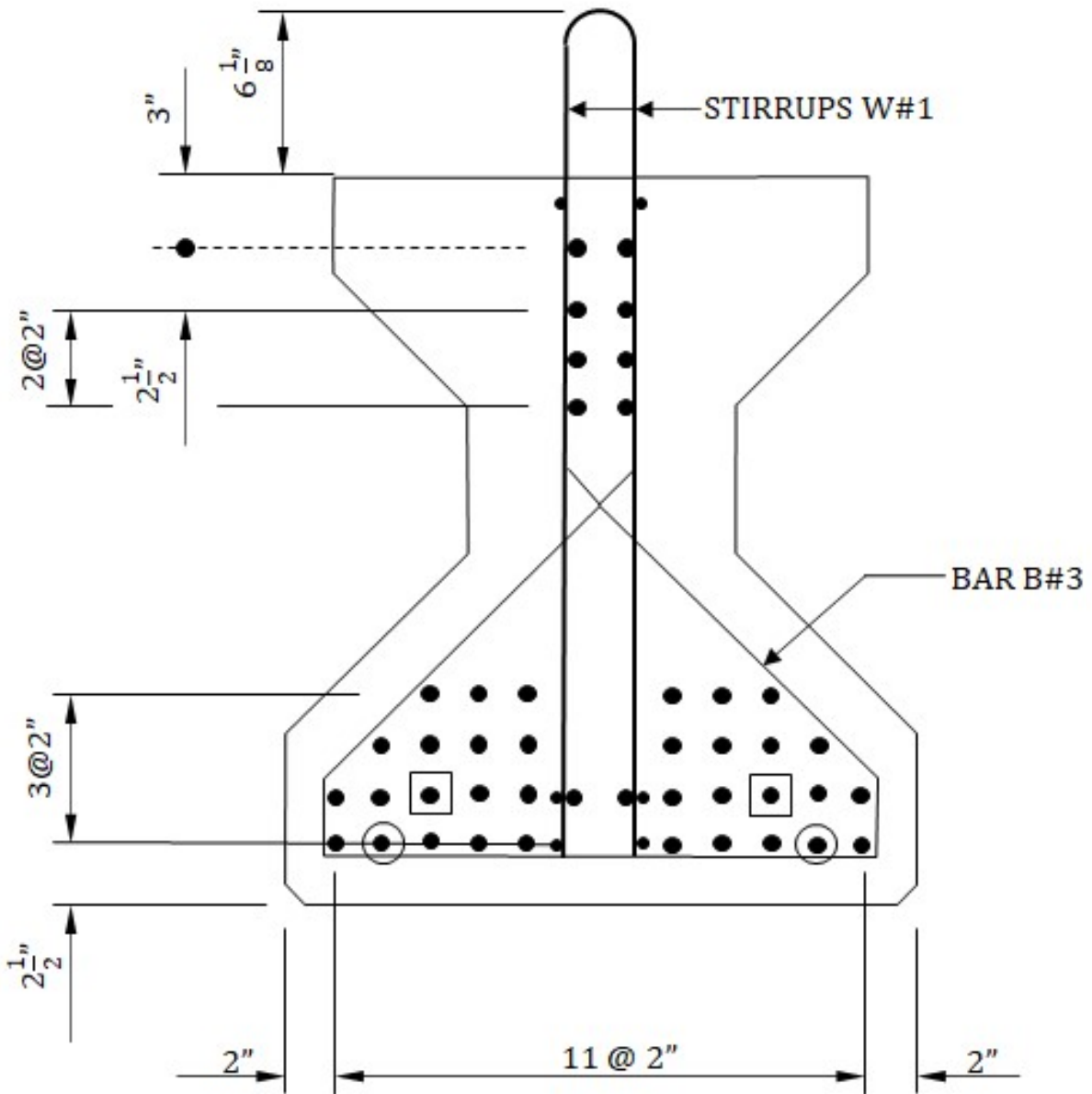

Figure 5-14 End cross section of modified AASHTO Type I girder

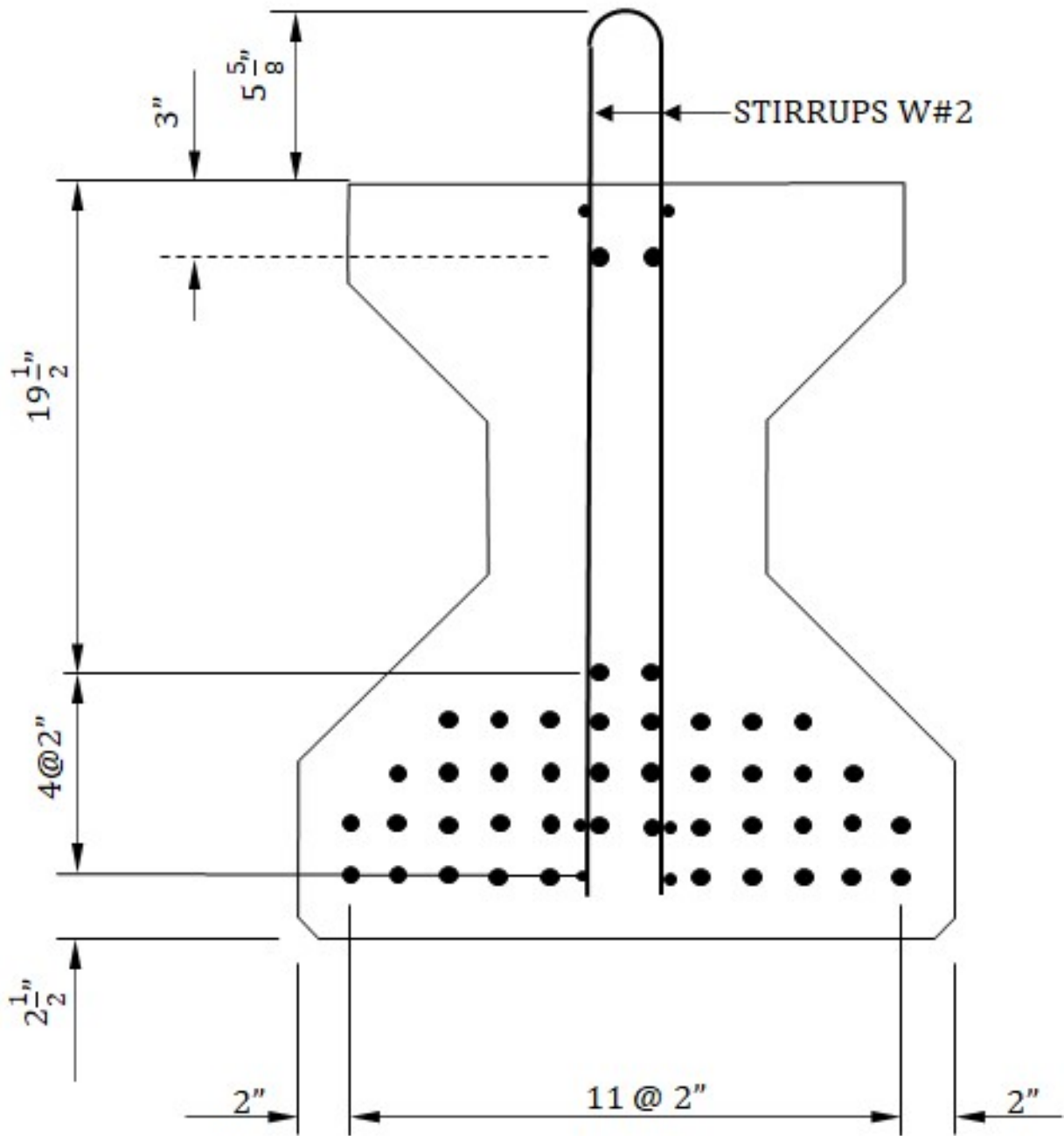

Figure 5-15 Cross section at the hold down point of the modified AASHTO Type I girder

<i>Modified AASHTO Type I Beam</i>							
			ALDOT		AASHTO		
<i>Location</i>	Distance from End (ft)	Av/s (in ² /ft)	Size	Spacing (in.)	Size	Spacing (in.)	Controlled by
<i>Bearing</i>	0.60	AZ Splitting	#7	4	D60*	4	AZ Splitting
<i>Transfer</i>	2.5	0.324	#5	4	D20	14	Interface Shear
<i>Critical</i>	3.18	0.307	#5	4	D20	14	Interface Shear
<i>0.1L</i>	7.92	0.220	#5	8	D20	20	Min Interface Shear
<i>0.2L</i>	15.84	0.220	#5	12	D20	20	Min Interface Shear
<i>0.3L</i>	23.76	0.197	#5	18	D20	22	Min Vertical Shear
<i>0.4L</i>	31.68	0.197	#5	18	D20	22	Min Vertical Shear
<i>0.5L</i>	39.6	0.197	#5	18	D20	22	Min Vertical Shear
<i>75 ksi Design Yield Strength</i>							
<i>Location</i>	Distance from End (ft)	Av/s (in ² /ft)	Size	Spacing	Size	Spacing	Controlled
<i>Bearing</i>	0.60	AZ Splitting	#7	4	D60*	4	AZ Splitting
<i>Transfer</i>	2.5	0.324	#5	4	D16	10	Interface Shear
<i>Critical</i>	3.18	0.307	#5	4	D16	12	Interface Shear
<i>0.1L</i>	7.92	0.220	#5	8	D16	16	Min Interface Shear
<i>0.2L</i>	15.84	0.220	#5	12	D16	16	Min Interface Shear
<i>0.3L</i>	23.76	0.157	#5	18	D16	22	Min Vertical Shear
<i>0.4L</i>	31.68	0.157	#5	18	D16	22	Min Vertical Shear
<i>0.5L</i>	39.6	0.157	#5	18	D16	22	Min Vertical Shear

Table 5-12 Shear design requirements for modified AASHTO Type I beam

*A D60 is an atypical wire size and represents an equivalent 0.60 in² area

Note: "AZ Splitting" indicates that the transverse reinforcement is controlled by anchorage zone reinforcement requirements (AASHTO 5.9.4.4.1).

The modified AASHTO Type I girder's required shear reinforcement area per foot is controlled by interface shear requirements and minimum vertical shear requirements. The interface shear requirement comes into play for this girder due to its smaller contact area with the deck slab. The lower area reduces the amount of shear transfer that the concrete can carry, thus increasing the amount of interface shear reinforcement required. The minimum vertical shear requirement begins to control towards the middle of the girder because the shear demand drops to the point where the minimum vertical shear reinforcement provides enough capacity to cover a 33 percent increase in the interface shear demand. It should be noted that the increase in design yield strength from 60 ksi to 75 ksi does not affect the interface shear requirements as AASHTO does not allow design yield strengths above 60 ksi to be used for calculating interface shear requirements. Unlike the previous girders, this girder requires spacings tighter than the maximum spacing size beyond the transfer length.

AASHTO's maximum stirrup spacing is 22 in. for this girder due to the effective shear depth (d_v) being less than 30 in. for some cross sections. Figure 5-16 shows the modified AASHTO Type I girder designed in accordance with ALDOT spacing specifications with WWR sheets using No. 5 and 4 equivalent (D31 and D20) wire sizes with design yield strengths of 60 ksi and 75 ksi, as well as a sample ALDOT design. Figure 5-17 shows this modified AASHTO Type I girder following only AASHTO requirements for WWR sheets with the same variations as Figure 5-16.

AL4G75	Satisfies ALDOT spacing requirements with grade 75 wire that has an equivalent yield force to a grade 60 #4 bar
AL4G60	Satisfies ALDOT spacing requirements with wire that has an equivalent area of a #4 bar
AL5G75	Satisfies ALDOT spacing requirements with grade 75 Wire that has an equivalent yield force to a grade 60 #5 bar
AL5G60	Satisfies all ALDOT requirements with wire that has an equivalent area of a #5 bar
DRAW	As drawn by ALDOT

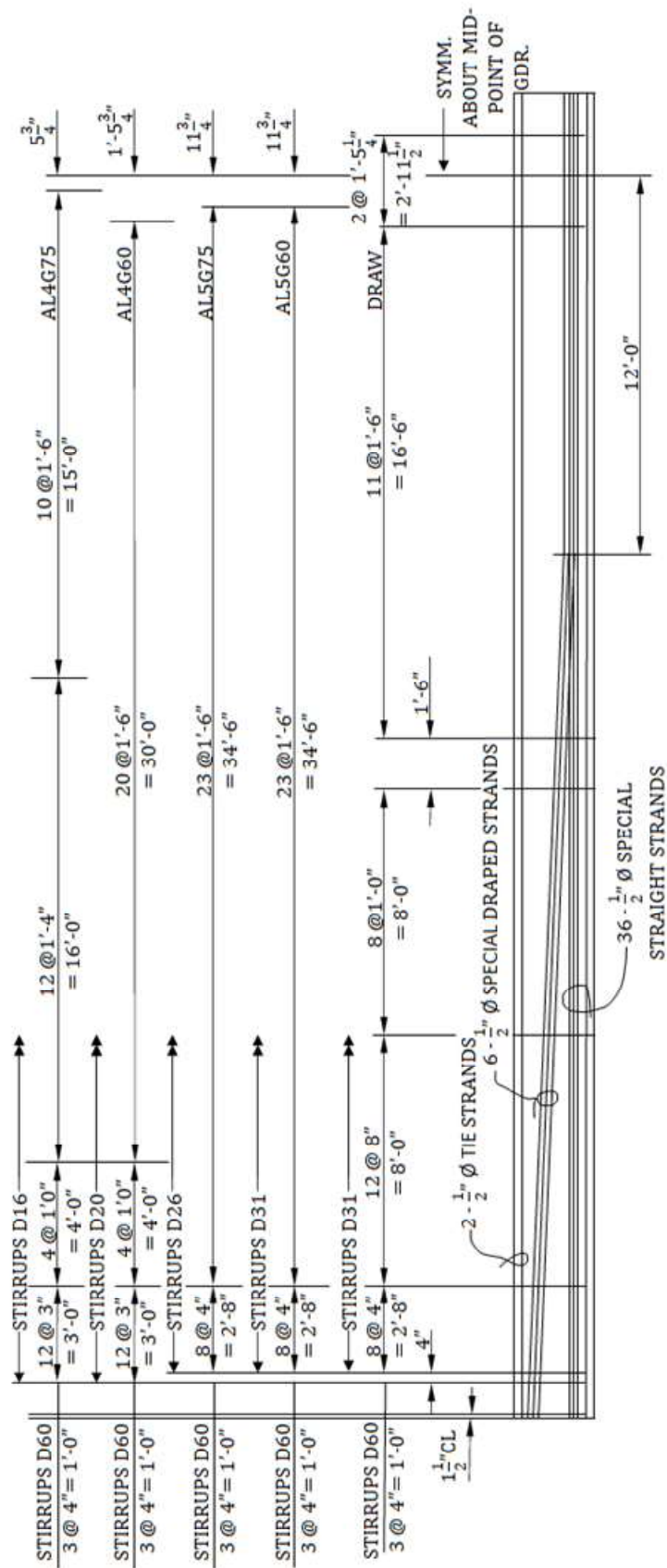

Figure 5-16 Modified AASHTO Type I girder potential stirrup spacing configurations that meet ALDOT spacing requirements

4G75	Satisfies all AASHTO requirements with grade 75 wire that has an equivalent yield force to a grade 60 #4 bar
4G60	Satisfies all AASHTO requirements with wire that has an equivalent area of a #4 bar
5G75	Satisfies all AASHTO requirements with grade 75 Wire that has an equivalent yield force to a grade 60 #5 bar
5G60	Satisfies all AASHTO requirements with wire that has an equivalent area of a #5 bar
DRAW	As drawn by ALDOT

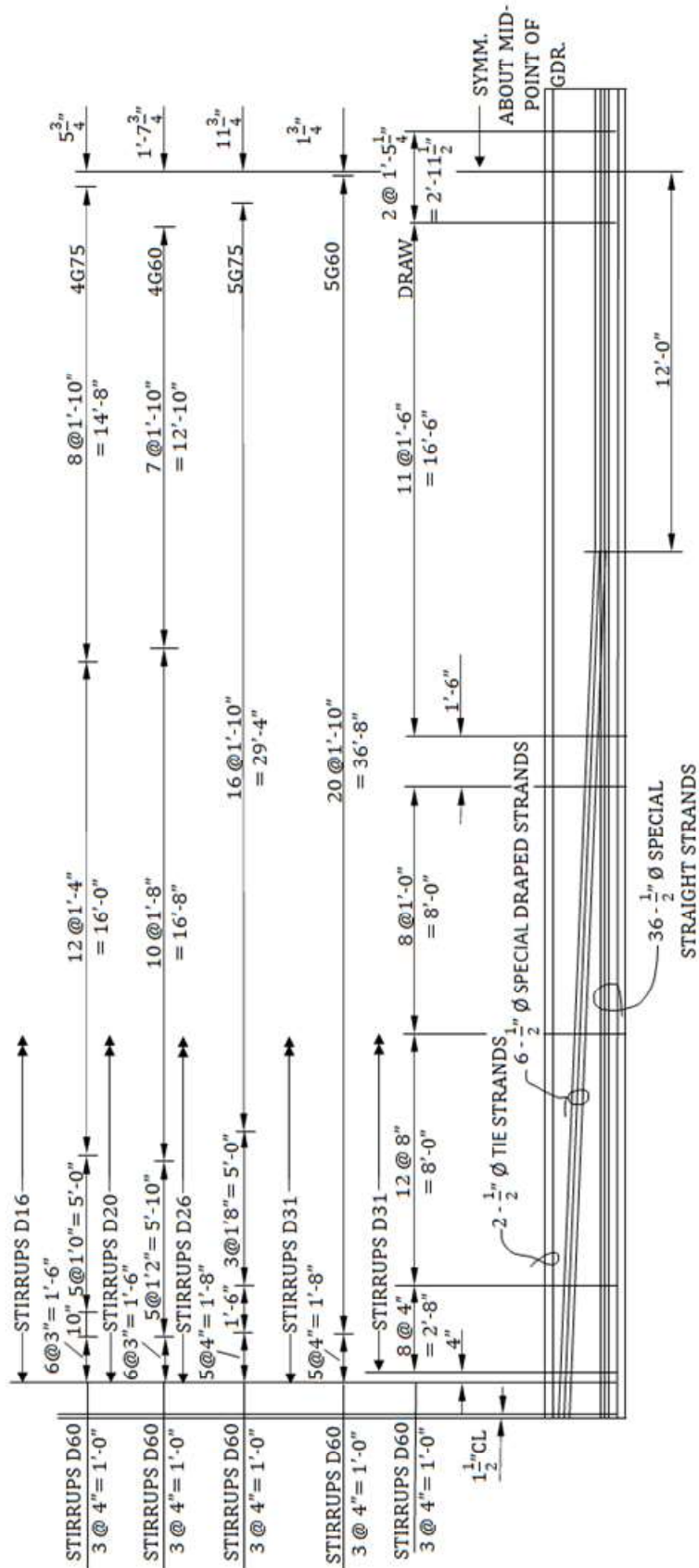

Figure 5-17 Modified AASHTO Type I girder potential stirrup spacing configurations that meet AASHTO requirements

The ALDOT drawing uses a set of stirrups at a 4 in. spacing for a girder depth in accordance with the ALDOT specification. This set of stirrups is therefore also seen in the other ALDOT stirrup layouts. The D20 and D16 stirrups require 3 in. spacings for this length to meet the interface shear demand at this section. The ALDOT drawing then uses a set of stirrups at an 8 in. spacing followed by a 12 in. spacing before going to the 18 in. maximum spacing. The 8 in. and 12 in. spacings are transition spacings that are not required by AASHTO requirements or by the ALDOT specification. The 18 in. ALDOT maximum spacing is sufficient for the D31 and D26 stirrups after the initial girder depth. The D20 stirrup layout requires some 12 in. spacings before reaching the maximum spacing. The D16 stirrup layout requires the same 12 in. spacing as the D20 stirrup layout. Since AASHTO does not allow the design yield strength to go above 60 ksi for interface shear, the D16 stirrup layout has 16 in. spacings where the minimum interface shear controls.

The AASHTO layouts show the same anchorage zone steel as the ALDOT layouts. Like the ALDOT layouts, the D31 and D26 stirrups start at 4 in. spacings and the D20 and the D16 stirrups at 3 in. spacings. Unlike the ALDOT, these spacings end at the transfer length of the prestressing steel rather than a girder depth. The D31 stirrups, once reaching the transfer length, go into the maximum spacing of 22 in. for this beam. The D26 stirrups require some stirrups at 18 in. spacings until only the minimum interface shear reinforcement is required. At this point, the D26 stirrups reach the maximum spacing. The D20 stirrups require some stirrups at 14 in. spacings until the minimum interface shear reinforcement is required. At which point, the D20 stirrups can be spaced at 18 in. and then 22 in. once minimum vertical shear controls. The D16 stirrups follow the same pattern as the D20 stirrups with tighter spacings due to smaller size and still reach maximum spacing with minimum vertical shear due to the increase in design yield stress.

The ALDOT requirement limiting the maximum spacing to 18 in. means the stirrup patterns following ALDOT requirements provide additional stirrups once maximum spacing is reached. The stirrup patterns following only AASHTO requirements provide about 20 percent fewer stirrups compared to their ALDOT counterpart. Due to the 3 in. spacing requirement at the end of the girder and requiring more stirrups, the

D20 and D16 wires may be less preferred over the larger D31 and D26 wires. However, this 3 in. spacing is seen in other states that use a No. 4 bar typical size such as Texas (2017). Due to interface shear controlling a significant portion of this girder, the benefit from the increase in design yield stress from 60 ksi to 75 ksi is reduced, especially for the D16 stirrups.

The AASHTO Type I modified section was fitted with the standardized sheets described in Table 5-2. The sheet layout for the ALDOT variations shown in Figure 5-16 are shown in Table 5-13 and the sheet layout for the AASHTO variations shown in Figure 5-17 are shown in Table 5-14.

Table 5-13 AASHTO Type I modified section stirrup gross quantities for ALDOT design variations

<i>AASHTO TYPE I MODIFIED ALDOT Variations</i>				
<i>Variation</i>	Stirrup weight (lb)	2-legged stirrups (No.)	Installed Elements (No.)	Sheets (No.)
<i>DRAW</i>	1020	111	222	N/A
<i>AL5G60</i>	732	77	25	8
<i>AL5G75</i>	654	77	25	8
<i>AL4G60</i>	670	103	27	10
<i>AL4G75</i>	586	110	26	10

Table 5-14 AASHTO Type I modified section stirrup gross quantities for AASHTO design variations

<i>AASHTO TYPE I MODIFIED AASHTO Variations</i>				
<i>Variation</i>	Stirrup weight (lb)	2-legged stirrups (No.)	Installed Elements (No.)	Sheets (No.)
<i>5G60</i>	732	77	25	8
<i>5G75</i>	654	77	25	8
<i>4G60</i>	553	82	24	8
<i>4G75</i>	524	96	24	8

Table 5-13 clearly shows a substantial (89 percent) reduction in the number of installed elements for the stirrups when switching from the typical reinforcing bar stirrups present in the original drawing to WWR stirrups even when a similar number of stirrups are being provided. The required 3 in. spacing for the smaller wires leads to

more stirrups, but similar overall stirrup weight compared to the larger wires. The difference between the ALDOT and AASHTO variations is the AASHTO variations could use standard sheets with 24 in. spacings instead of 18 in. spacings. The longer length of the 24 in. spacing sheet leads to the AASHTO variations using less sheets.

5.7 CONCLUSIONS FROM DESIGN COMPARISONS

All girder's designed experience a drastic reduction (85-90 percent) in the number of stirrup elements when employing WWR over reinforcing bars. This reduction in individual elements and thus installation operations in the prestress bed is the major benefit received when WWR is employed as stirrups. The implementation of longer standardized sheets may further this reduction in elements at the cost of providing additional stirrups and increased difficulty placing the sheets. For these girders, the example standardized sheets provided in Table 5-2 appear to be of adequate lengths providing similar or less stirrups as their reinforcing bar counterpart while providing a significant reduction in installed elements.

The modified BT-74 girder, AASHTO Type III girder, and the BT-72 girder all satisfy AASHTO shear reinforcement requirements largely by providing stirrups at the maximum allowable spacing. These girders see their D20 stirrups having the same spacings as D31 stirrups if the 4 in. spacing for a girder length is maintained. Otherwise, the D31 wires can save a few stirrups by using 6 in. spacings instead. The D26 and D16 stirrups have the same spacings as their counterparts, thus fully utilizing their increase in design yield strength to 75 ksi. These girders see the largest benefit in the reduction of stirrup size, because they are largely reinforced by stirrups at maximum spacing for all sizes.

In contrast to these girders, the modified AASHTO Type I girder required tighter spacings as the stirrup size was reduced. This girder is the shortest and smallest girder with four debonded strands. It is also largely controlled by interface shear requirements that see no reduction in shear requirement resulting from an increase in design yield stress beyond 60 ksi due to AASHTO limitations. All of these qualities reduce the benefit of using smaller stirrup sizes. The modified AASHTO Type I girder, like the

modified BT-74 girder, requires stirrups sizes larger than D45 for anchorage zone reinforcement. The largest typical size for WWR is D45, so for these girders their stirrups would need to be tied together (bundled) to achieve an equivalent stirrup size of a D60 wire. The use of this 3 in. spacing at these anchorage zones, while creating more congestion, would reduce the size of stirrups required for splitting resistance possibly from a D60* to a D45. This 3 in. spacing would also permit the D20 and D16 stirrups sizes for this modified AASHTO Type I that requires this 3 in. spacing until the transfer length is reached. Note that both cross sections that require this wire size are highly prestressed and were modified to accommodate additional strands.

ALDOT drawings typically have girder segments with stirrup spacings much less than required by the specification. The purpose of these segments is to more smoothly transition from small stirrup spacings in the end region to the maximum allowable spacing, even though the maximum spacing provides adequate strength. Because these segments tend to be much more conservative than required, they can be easily standardized in spacing and length. This standardization would offset some of the cost of providing WWR stirrups tighter than required.

CHAPTER 6: SUMMARY, CONCLUSIONS, AND RECOMMENDATIONS

6.1 SUMMARY

This thesis research was conducted to gain insight into the potential benefits and impediments associated with the use of welded wire reinforcement (WWR) as shear reinforcement in prestressed concrete bridge girders. With better understanding of WWR, more cost-effective bridge designs may become reality as state departments of transportation (DOTs) are not currently unified on WWR's acceptability or scheme.

The manufacturing process and mechanical properties of WWR are discussed based on previous research performed. The relation of these mechanical properties and the unique codified requirements relating to WWR are also discussed. The current state of practice among state DOTs was surveyed to determine the best practices of WWR as subject to the different expectations and requirements by state DOTs. This wealth of experience in using WWR as shear reinforcement is important to determine best practices. The general interest in the adoption of WWR by state DOTs that do not permit its use was gaged to determine to potential impact of spreading information related to WWR. The constructability of WWR was investigated through an interview with engineers working at a precast plant that used the product as well as available guides. A shear design of four ALDOT girders was performed with WWR as stirrups to determine if WWR properties had any design benefits over standard reinforcing bars for ALDOT's specific standards. Different variations of each design were performed considering (a) design yield strength of 60 ksi or 75 ksi, (b) standard stirrup size of No. 5 bar equivalent (D31) or No. 4 bar equivalent (D20), and (c) adherence to strict ALDOT spacing requirements at the ends of the girder.

The results of these investigations are discussed in their respective chapters. The overall observations and conclusions from this project are presented in Chapter 6.2. Recommendations drawn from these conclusions are offered in Chapter 6.3.

6.2 OBSERVATIONS AND CONCLUSIONS

This investigation into the performance and state of practice of WWR as shear reinforcement supports the following conclusions:

- WWR has a higher yield strength and lower ductility compared to typical reinforcing bars.
- WWR drastically reduces the number of stirrup installation operations in the prestress bed by 85-90 percent compared to bar stirrups
- Compared to conventional reinforcing bar stirrups, WWR is much faster and more reliably installed as shear reinforcement.
- WWR performs as effectively as conventional reinforcing steel stirrups for monotonic shear strength.
- Deformed WWR appears to perform as well or possibly better in controlling shear cracks when compared to conventional reinforcing steel for monotonic and cyclic loadings.
- The development of WWR stirrups by two cross-wires as a replacement or in support of hooks is well supported to be sufficient for monotonic and cyclic loading.
- The welds present in WWR can be susceptible to high fatigue stresses developed in cyclic loading.
- When welds are located in the clear web between the flanges, they are vulnerable to shear fatigue stresses and are subject to more stringent fatigue requirements
- WWR benefits from a great degree of standardization of girder cross sections and standard stirrup design spacings.
- Significant interest exists among state DOTs in allowing WWR as shear reinforcement, interface-shear reinforcement, and supplemental anchorage zone reinforcement.
- WWR is permitted for use as shear reinforcement among at least 30 percent of state DOTs.

- Of the states that do permit its use, preference is split between WWR and reinforcing steel, with most having no preference.
- An increase in the design yield stress to 75 ksi shows slight benefit with proportional reduction in stirrup size.
- Because most stirrup spacings are controlled by maximum spacing limits, reduction in stirrup size shows a significant reduction in total stirrup weight.

6.3 RECOMMENDATIONS FOR WELDED WIRE REINFORCEMENT USE

Since WWR structural performance is on par with typical reinforcing steel with much faster installation, WWR should be allowed for use as shear reinforcement in precast, prestressed concrete bridge girders.

There are important considerations when designing for welded wire use as shear reinforcement to improve its cost-effectiveness. These additional recommendations include

- Standardize stirrup spacings and length of same spacings for typical bridge geometries and concrete strengths;
- Standardize girder cross section selection;
- Allow the use of cross-wires for development and remove unnecessary hooks;
- Avoid 90-degree hooks projecting from the top of the girder;
- Ensure cross-wire welds are not present in the thin portion of the web subjected to high-shear demands;
- Permit the tying of reinforcing bars to WWR stirrups to achieve a larger effective stirrup area in the anchorage zone; and
- Investigate the implementation of stirrup sizes smaller than No. 5 bars (D31 wires).

6.4 RECOMMENDATIONS FOR FUTURE RESEARCH

WWR is currently restricted from being designed with its full yield strength above 60 ksi for interface shear. Investigation to determine if WWR can perform according to its

increase in yield strength for interface shear would be valuable for girders in which interface shear demand is a controlling mechanism.

Other topics that could be further investigated include

- Development of standard concrete strengths, cross sections, strand configurations, and WWR stirrup configurations for common ranges of ALDOT bridge geometries;
- Development requirements for WWR as horizontal shear (interface) reinforcement using cross-wires and/or hooks;
- Performance of horizontal shear (interface) reinforcement 180-degree hooks that extend a constant distance out of the girder versus 90-degree hooks that extend to the mid-depth of the slab;
- Performance of stirrups smaller than No. 5 bars (D31 wires) as shear reinforcement in ALDOT precast, prestressed girders;
- Performance of WWR and typical reinforcing stirrups spaced at greater than 18 in. as minimum shear reinforcement in ALDOT precast, prestressed girders;
- Fatigue performance of WWR and placement requirements for anchoring cross-wires for WWR stirrups in standard prestressed concrete bridge girder cross sections;
- Required length of cross-wires when used for anchorage for smooth and deformed WWR stirrups; and
- Justification and guidelines for employing transitional stirrup spacings between (a) the 4 in. spacing in anchorage zones and (b) the maximum spacing allowed (18 in. or 24 in.), when no intermediate spacing is required by AASHTO to provide adequate strength.

References

- American Association of Highway and Transportation Officials. 2020. *AASHTO LRFD Bridge Design Specifications*. 9th. Washington D.C.: American Association of State Highway and Transportation Officials.
- American Concrete Institute Committee 318. 2019. *Building Code Requirements for Structural Concrete and Commentary*. Farmington Hills, MI: American Concrete Institute.
- Amorn, W., Bowers, J., Girgis, A., & Tadros, M. K. 2007. Fatigue of deformed welded-wire reinforcement, *Precast/Prestressed Concrete Institute Journal*. 52(1), 106–120. <https://doi.org/10.15554/pcij.01012007.106.120>
- American Society for Testing and Materials. 2018. Standard specification for carbon-steel wire and welded wire reinforcement, plain and deformed, for concrete. ASTM A1064-18a. American Society for Testing and Materials.
- Ayyub, B. M., Al-Mutairi, N., & Chang, P. C. 1994a. Bond strength of welded wire fabric in concrete bridge decks. *Journal of Structural Engineering*. 120(8), 2520-2531. [https://doi.org/10.1061/\(ASCE\)0733-9445\(1994\)120:8\(2520\)](https://doi.org/10.1061/(ASCE)0733-9445(1994)120:8(2520))
- Ayyub, B. M., Al-Mutairi, N., & Chang, P. C. 1994b. Welded wire fabric for bridges. I: Ultimate strength and ductility. *Journal of Structural Engineering*. 120(6), 1866–1881. [https://doi.org/10.1061/\(ASCE\)0733-9445\(1994\)120:6\(1866\)](https://doi.org/10.1061/(ASCE)0733-9445(1994)120:6(1866))
- Ayyub, B. M., Al-Mutairi, N., & Chang, P. C. 1994c. Welded wire fabric for bridges. II: Fatigue strength. *Journal of Structural Engineering*. 120(6), 1882-1892. [https://doi.org/10.1061/\(ASCE\)0733-9445\(1994\)120:6\(1882\)](https://doi.org/10.1061/(ASCE)0733-9445(1994)120:6(1882))
- Bernold, L. E., & Chang, P. 1992. Potential gains through welded-wire fabric reinforcement. *Journal of Construction Engineering and Management*. 118(2), 244–257. [https://doi.org/10.1061/\(ASCE\)0733-9364\(1992\)118:2\(244\)](https://doi.org/10.1061/(ASCE)0733-9364(1992)118:2(244))
- Carrillo, J., Rico, A., & Alcocer, S. 2016. Experimental study on the mechanical properties of welded-wire meshes for concrete reinforcement in Mexico City. *Construction and Building Materials*. 127, 663–672. <https://doi.org/10.1016/j.conbuildmat.2016.10.011>
- Colorado Department of Transportation. 2020. Prestressed Concrete I. Colorado Department of Transportation.
- Commonwealth of Pennsylvania Department of Transportation. 2013. PA Bulb-Tee Beam WWR Details Standard. Northeast Prestressed Products.

Durrani, A. J., & Ian, R. N. 1987. Shear strength of prestressed concrete T beams with welded wire fabric as shear reinforcement. *Precast/Prestressed Concrete Institute Journal*. 32(2), 46-61. <https://doi.org/10.15554/pcij.03011987.46.61>

Florida Department of Transportation. 2022. Florida-I 63 beam- Standard details. *FY 2021-22 Standard Plans*. 450-063.

Griezic, A., Cook, W. D., & Mitchell, D. 1994. Tests to determine performance of deformed welded wire fabric stirrups. *American Concrete Institute Structural Journal*. 91(2), 211–220.

lordachescu, M., Valiente, A., & De Abreu, M. 2019. Fatigue life assessment of a tack welded high-strength wire mesh for reinforcement of precast concrete bridge girders. *Construction and Building Materials*.197, 421-427. <https://doi.org/10.1016/j.conbuildmat.2018.11.176>

Joint PCI/WRI Ad Hoc Committee on Welded Wire Fabric for Shear Reinforcement. 1980. Welded Wire Fabric for Shear Reinforcement. *318 Reference*. 12(29), 32-36.

Louisiana Department of Transportation and Development. 2018. LG-25- Reinforcement welded wire reinforcement. Louisiana Department of Transportation and Development.

Maguire, M., Morcous, G., & Tadros, M. K. 2013. Structural performance of precast/prestressed bridge double-tee girders made of high-strength concrete, welded wire reinforcement, and 18-mm-diameter strands. *Journal of Bridge Engineering*. 18(10), 1053-1061. [https://doi.org/10.1061/\(ASCE\)BE.1943-5592.0000458](https://doi.org/10.1061/(ASCE)BE.1943-5592.0000458)

Mansur, M. A., Lee, C. K., & Lee S. L. 1987. Deformed wire fabric as shear reinforcement in concrete beams. *American Concrete Institute Structural Journal*. 84(5), 392-399. <https://doi.org/10.14359/1649>

Missouri Highways and Transportation Commission. 2021. PSI_06_NU_WWR.dgn. Missouri Highways and Transportation Commission.

Morcous, G., Maguire, M., & Tadros, M. K. 2011. Welded-wire reinforcement versus random steel fibers in precast, prestressed concrete bridge girders. *Precast/Prestressed Concrete Institute Journal*. 56(2). 113-129. <https://doi.org/10.15554/pcij.03012011.113.129>

Pincheira, J. A., Rizkalla, S. H., & Attiogbe, E. K. 1989. Performance of welded wire fabric as shear reinforcement under cyclic loading. *American Concrete Institute Structural Journal*. 86(6). 728–735. <https://doi.org/10.14359/2770>

Precast/Prestressed Concrete Institute. 2017. *PCI Design Handbook*. 8th. Chicago, IL: Precast/Prestressed Concrete Institute.

State of Illinois Department of Transportation. 2021. IL90 Beam. State of Illinois Department of Transportation.

State of Ohio Department of Transportation. 2021. Prestressed concrete I-beam details. State of Ohio Department of Transportation.

Texas Department of Transportation. 2017. Prestressed concrete I-girder details. Texas Department of Transportation.

Wire Reinforcement Institute. 2003. Bending welded wire reinforcement for reinforced concrete 11th. Wire Reinforcement Institute.

Wire Reinforcement Institute. 2016. Structural welded wire reinforcement. *Manual of Standard Practice* 9th. Fairfax, VA: Wire Reinforcement Institute.

Wire Reinforcement Institute. 2021. *Welded Wire Reinforcement Design and Detailing Guide*. Fairfax, VA: Wire Reinforcement Institute.

Xuanl, X., Rizkalla, S., & Maruyama K. 1988. Effectiveness of welded wire fabric as shear reinforcement in pretensioned prestressed concrete T-beams. *American Concrete Institute Structural Journal*. 85(4). 429-436. <https://doi.org/10.14359/2711>

Yount, T., Sorensen, T., Collins, W., & Maguire, M. 2021. Investigating the mechanical properties and fracture behavior of welded-wire reinforcement. *Journal of Materials in Civil Engineering*. 33(4), [https://doi.org/10.1061/\(ASCE\)MT.1943-5533.0003622](https://doi.org/10.1061/(ASCE)MT.1943-5533.0003622)

APPENDIX A: STATE DRAWINGS

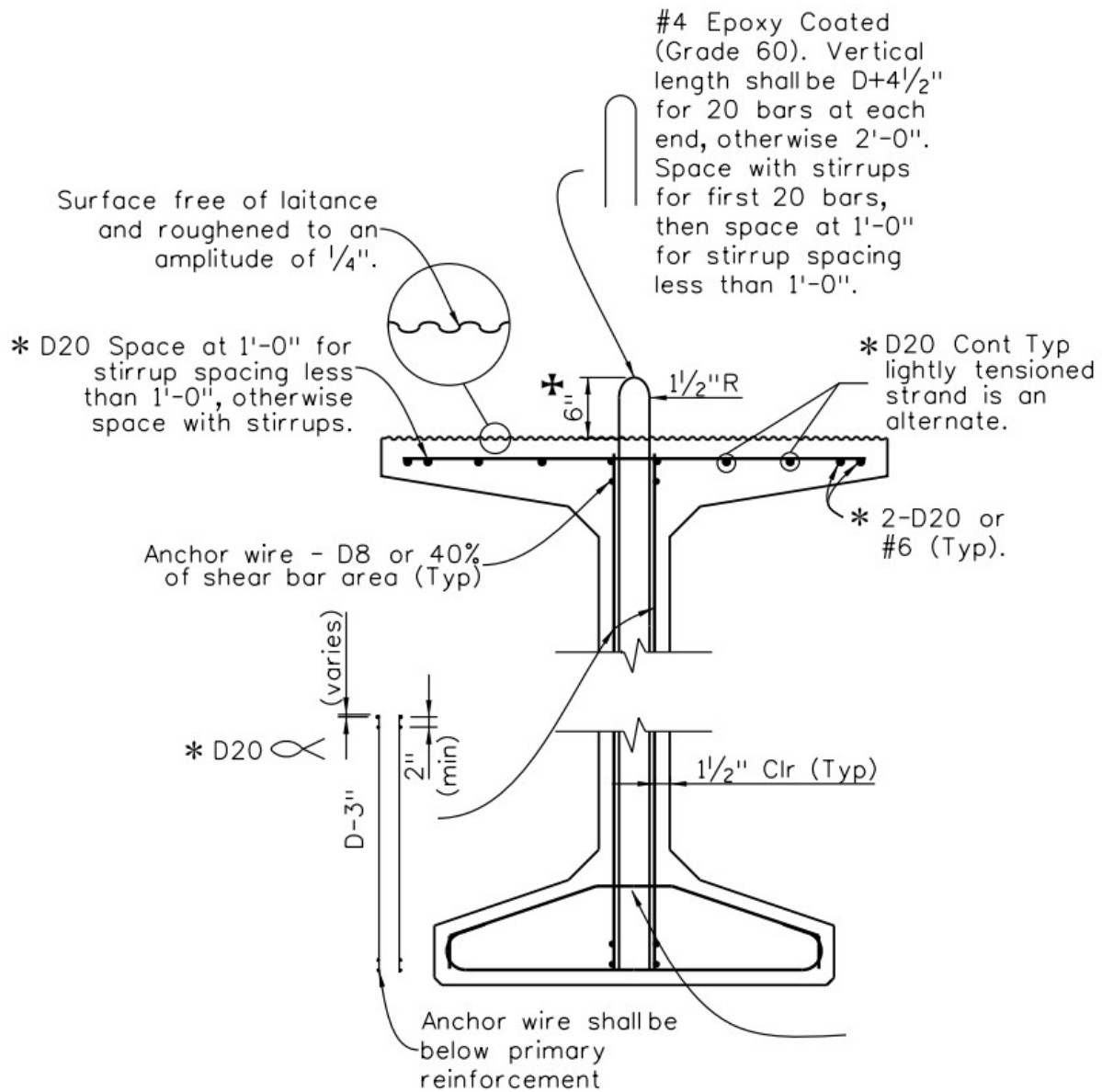

Figure A-1 Colorado stirrup details showing WWR use as shear reinforcement but not as interface shear reinforcement (Colorado Department of Transportation 2020)

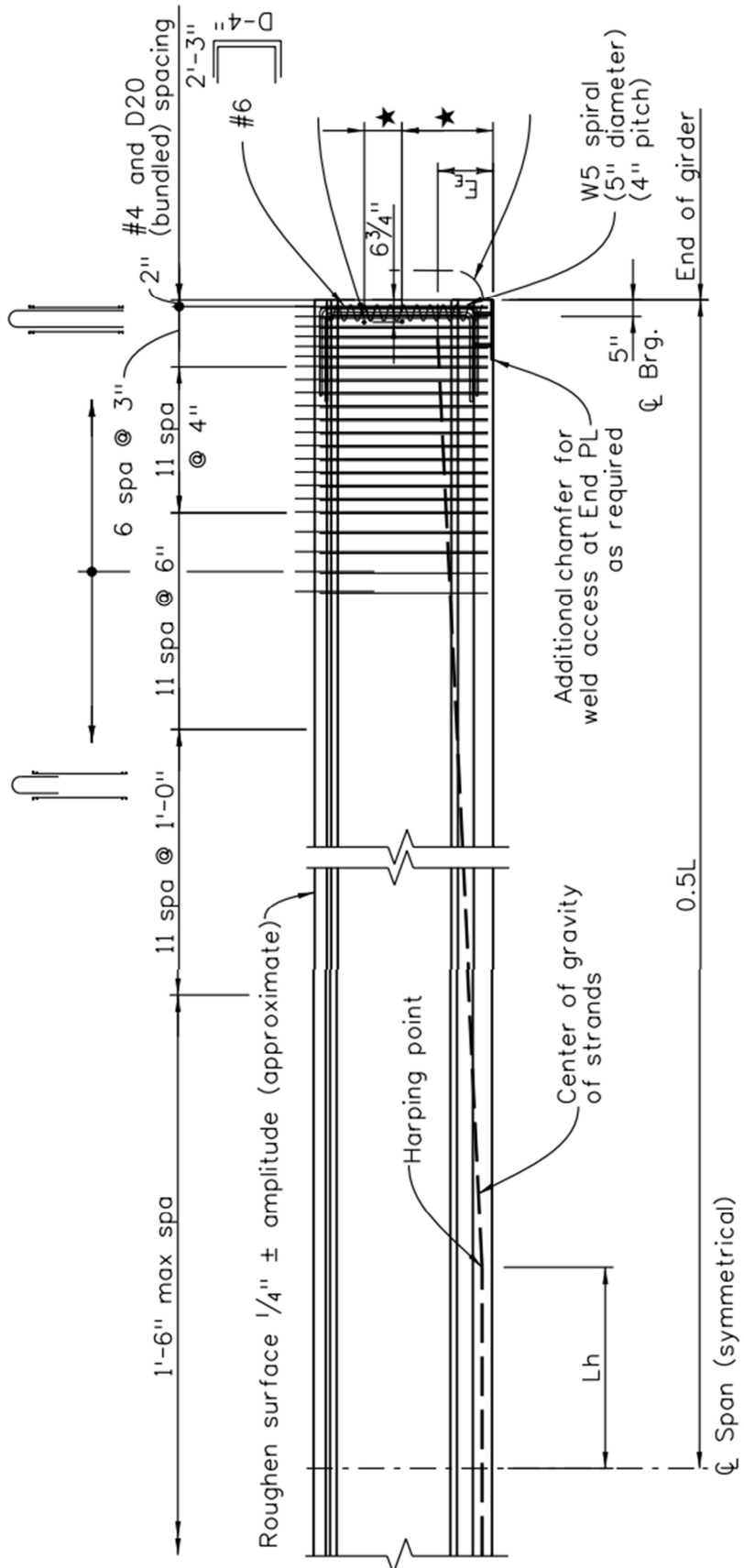

Figure A-2 Colorado standard stirrup spacings (Colorado Department of Transportation 2020)

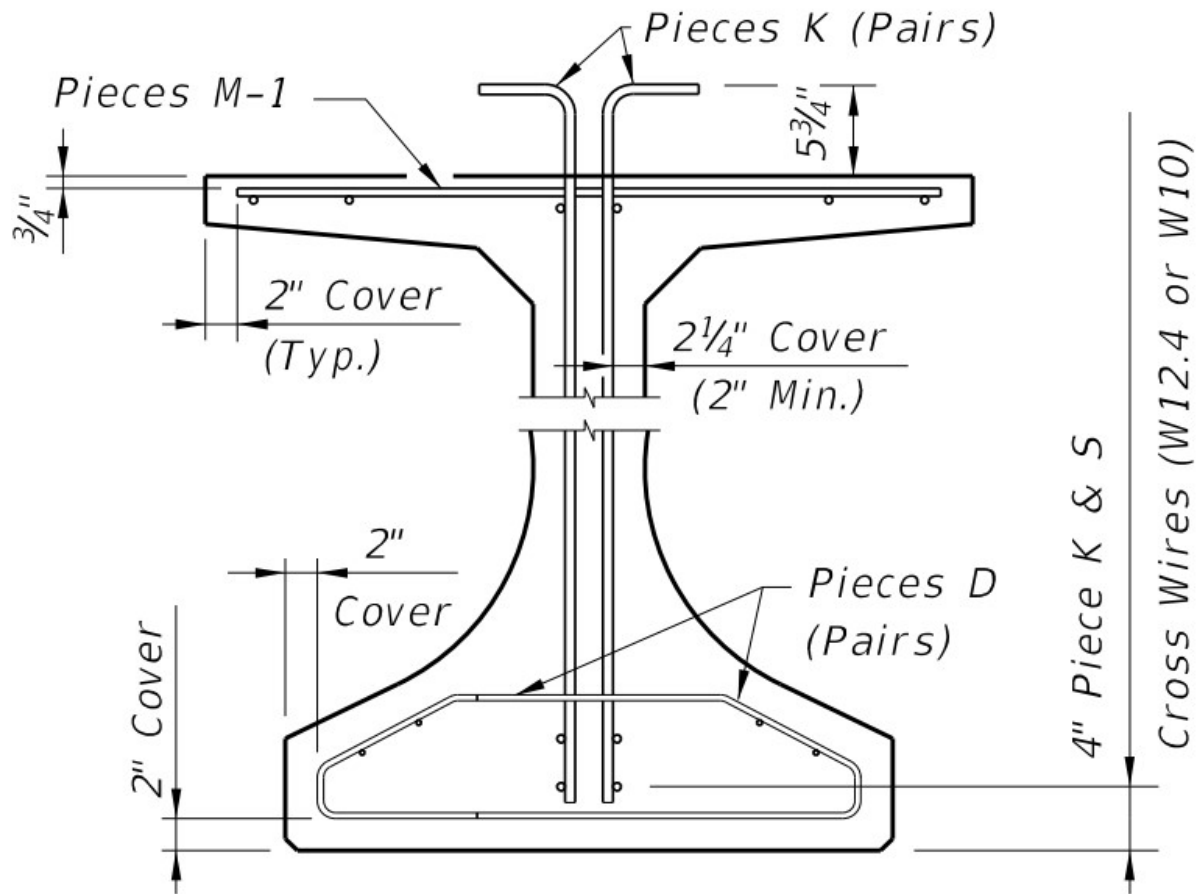

Figure A-3 Florida I-61 beam alternate details for using WWR (Pieces K) D31 at ends D25 elsewhere (Florida Department of Transportation 2022)

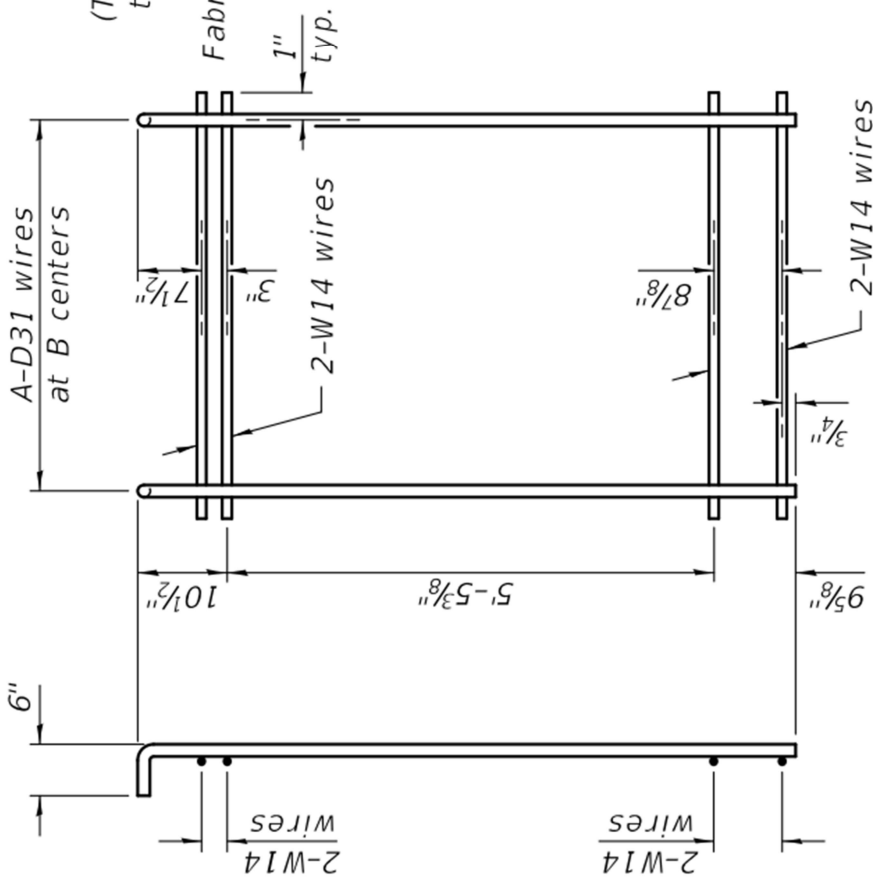

TABLE OF DIMENSIONS

(The WWR designs assume grade 60. If necessary, this permits the fabricator to directly substitute grade 60 rebar as detailed in the Manual for Fabrication of Precast Prestressed Concrete Products.)

SPAN

WWR	A	B
M2	9	3"
M3	21	6"
M4	-	1'-6"
M5	24	3"
M6	-	6"
M7	-	1'-0"
M8	-	2'-0"

Figure A-4 Illinois standard WWR stirrups and spacings IL90 beam (State of Illinois Department of Transportation 2021)

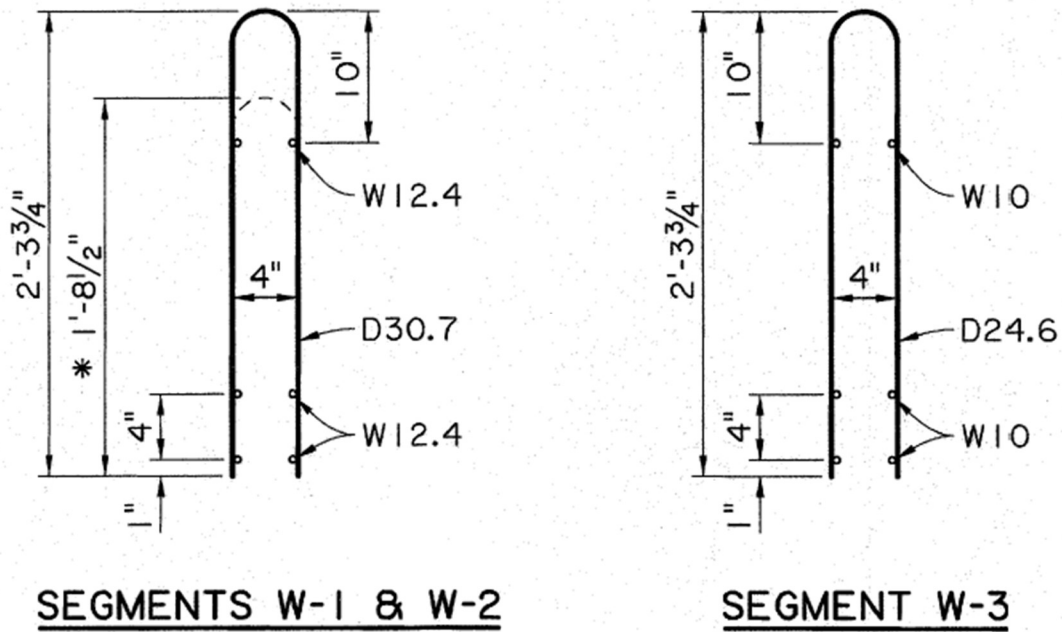

Figure A-5 Louisiana LG25 WWR Stirrups (Louisiana Department of Transportation and Development 2018)

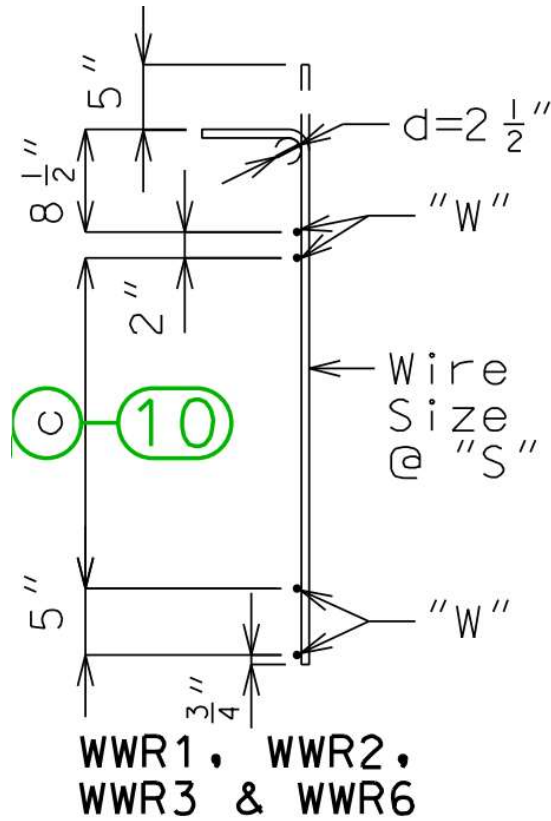

Figure A-6 Missouri PSI-06-NU-WWR stirrup design (Missouri Highways and Transportation Commission 2021)

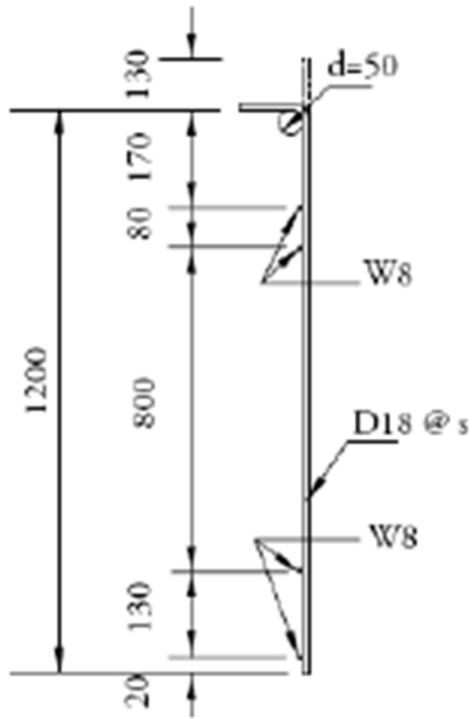
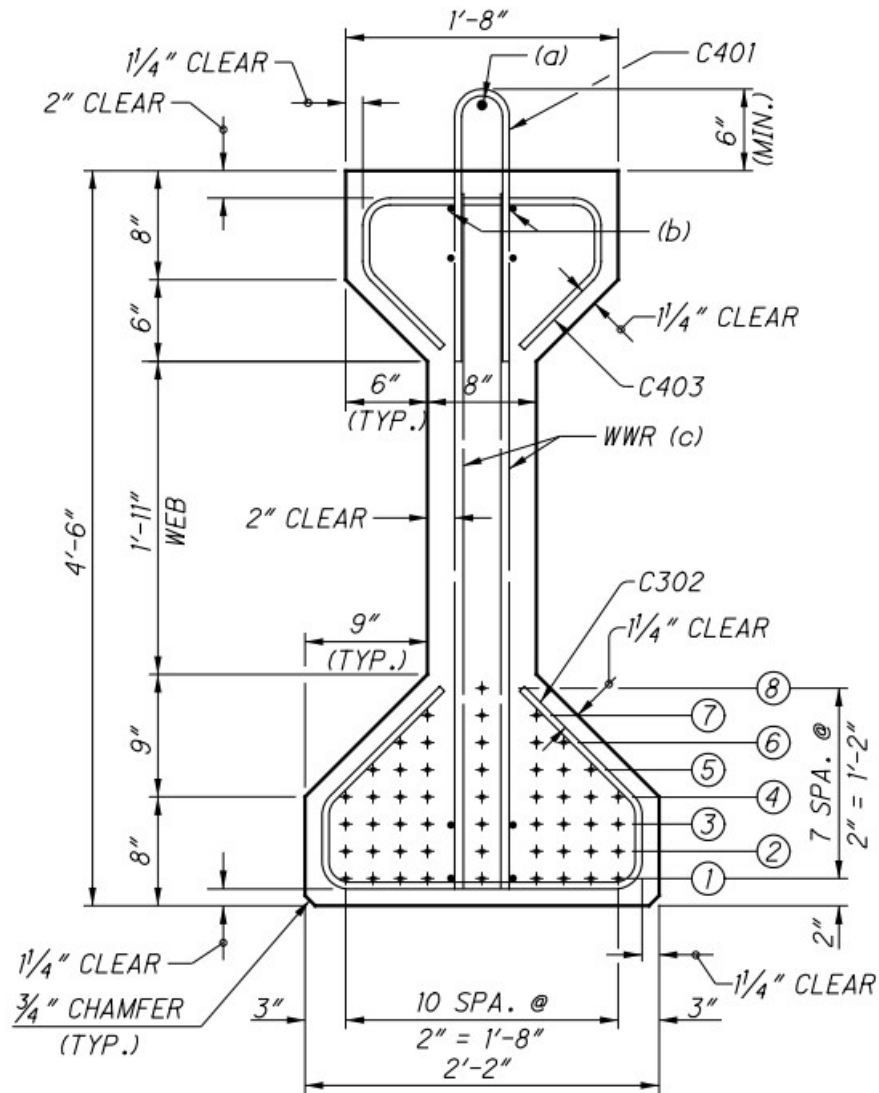
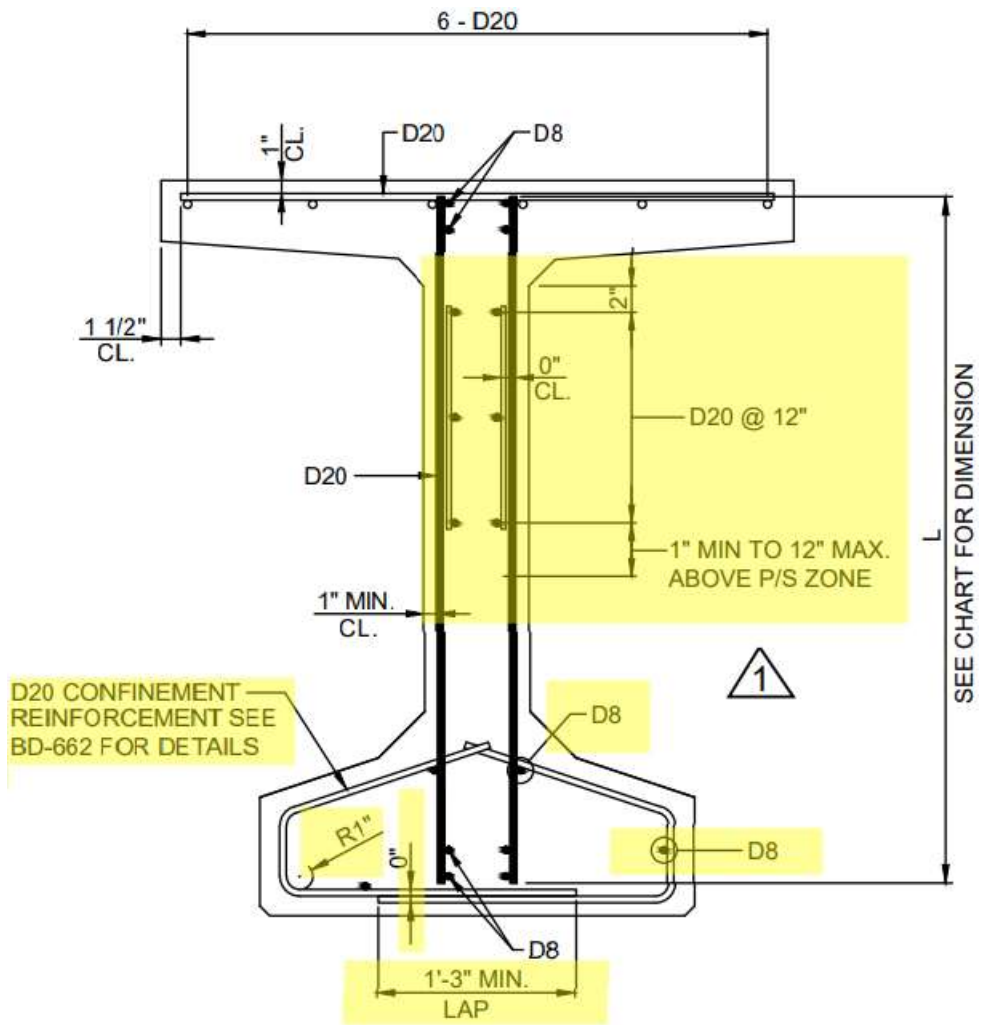

Figure A-7 Nebraska WWR Stirrups as found in PCI Design Manual (Precast/Prestressed Concrete Institute 2014)



AASHTO TYPE 4

Figure A-8 Ohio AASHTO type 4 girder has WWR as shear reinforcement. (State of Ohio Department of Transportation 2021)



PA BULB-TEE BEAM - WWR SECTION

Figure A-9 Pennsylvania bulb-tee girder WWR as shear reinforcement
(Commonwealth of Pennsylvania 2013)

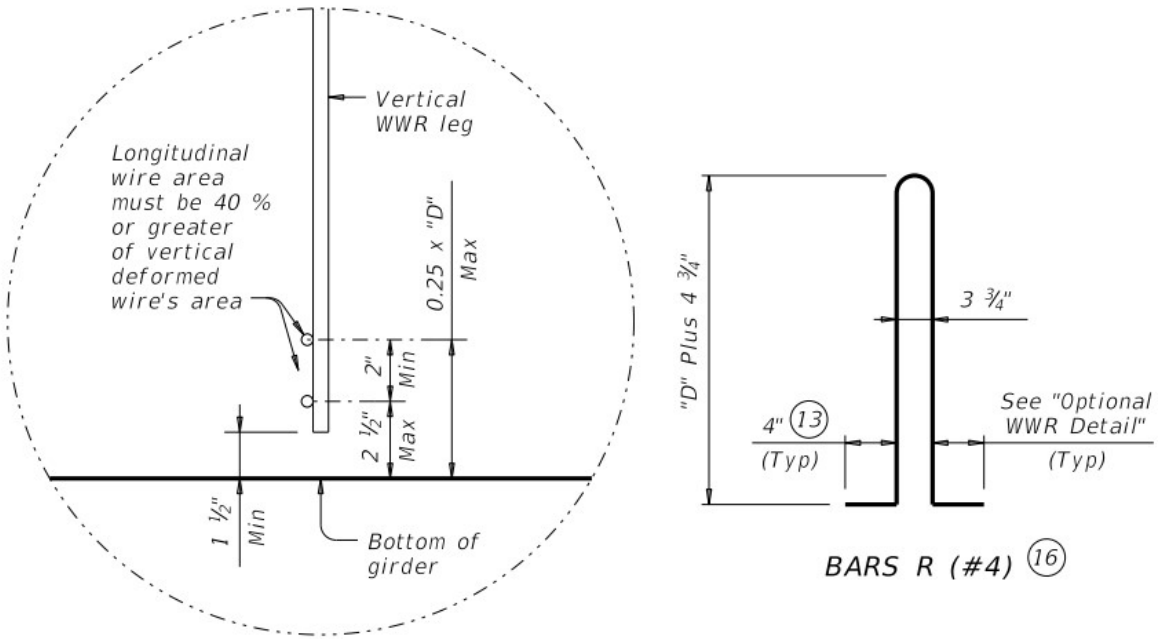

OPTIONAL WELDED WIRE REINFORCEMENT (WWR) DETAIL

Figure A-10 Texas optional WWR substitution and bottom detail (Texas Department of Transportation 2019)

APPENDIX B: CALCULATIONS

MODIFIED BT BEAM

Table B-1 Geometric and basic material properties of the modified BT girder

Geometric and Material Properties								
h	74	in	dts 0.4L	22.5	in	f'c deck	4	ksi
htotal/2	41.625	in	dts end	68.5	in	E deck	4949	ksi
Act	538	in ²	dp crit.	60.33	in	b deck	76.75	in
Ec	6090	ksi	dp 0.4L	75.11	in	t deck	7	in
Strands	56		0.4L	66.63	ft	t Haunch	2.25	in
Draped Strands	20		α_1	0.85		b Haunch	44	in
Aps 1strand	0.217		β_1	0.85		b top	44	in
fpu	270	ksi	fpe	172.2	ksi	t top	3.5	in
Strand dia.	0.6	in	Eps	28500	ksi	bw	8	in
f'c	7.5	ksi	fps	198.29	ksi	Ldev	80.15	in
fty	60	ksi				Ltransfer	36	in

Table B-2 Determining shear angle and beta of the modified BT girder

Location (ft)	Shear Strength							
Vu (kips)	Strands	bv (in)	de (in)	Aps (in ²)	Vp (kips)	ϵ_s	Θ	
Mcor (kft)		a (in)	dv (in)	fpo (ksi)	vu/fc	Vc-com (kips)	β	
Bearing	0.71							
359.9	36	8	78.08	1.602	10.135	6.000E-03	50	
0		2.05	77.06	44.625	0.084	46.56	0.87	
Transfer	3							
351.3	36	8	78.08	7.812	42.925	-1.823E-04	28.36	
765.7		10.49	72.84	189	0.079	280.38	5.56	
Critical	6.7							
337.4	36	8	78.08	7.812	42.925	-1.836E-04	28.36	
1892.2		12.42	71.87	189	0.077	276.99	5.57	
0.1L	16.66							
300.1	40	8	74.60	8.68	42.925	-1.099E-04	28.62	
4823.7		18	67.14	189	0.072	243.16	5.23	
0.2L	33.31							
240	52	8	69.06	11.284	42.925	-5.740E-05	28.80	
8593.2		19.56	62.15	189	0.060	215.83	5.02	
0.3L	49.97							
181.1	56	8	71.00	12.152	42.925	-1.444E-05	28.95	
11122.1		20.18	63.90	189	0.041	214.67	4.85	
0.4L	66.63							
123.6	56	8	75.11	12.152	0.000	1.161E-04	29.41	
12467.8		20.44	67.60	189	0.034	206.64	4.42	
0.5L	83.28							
67.3	56	8	75.11	12.152	0.000	6.610E-05	29.23	
12687.4		20.44	67.60	189	0.018	214.02	4.57	

Table B-3 Required stirrups for shear strength at 60 ksi design yield strength for the modified BT girder

Location (ft)	Shear Strength ($f_{ty} = 60$ ksi)			
Vu (kips)	Vs reqd (kips)	Av/s (in ² /ft)	Size	
Mcor (kft)	Max spc (in)	min Av/s (in ² /ft)	Spacing (in)	
Bearing				
359.9	343.19	1.062	D20	
0	24	0.138		4.52
Transfer				
351.3	67.03	0.138	D20	
765.7	24	0.138		24.00
Critical				
337.4	54.98	0.138	D20	
1892.2	24	0.138		24.00
0.1L				
300.1	47.36	0.138	D20	
4823.7	24	0.138		24.00
0.2L				
240	7.91	0.138	D20	
8593.2	24	0.138		24.00
0.3L				
181.1	0	0.138	D20	
11122.1	24	0.138		24.00
0.4L				
123.6	0	0.138	D20	
12467.8	24	0.138		24.00
0.5L				
67.3	0	0.138	D20	
12687.4	24	0.138		24.00

Table B-4 Required stirrups for shear strength at 75 ksi design yield strength for the modified BT girder

Location (ft)	Shear Strength (f _{ty} = 75 ksi)			
V _u (kips)	V _s reqd (kips)	A _v /s (in ² /ft)	Size	
M _{cor} (kft)	Max spc (in)	min A _v /s (in ² /ft)	Spacing (in)	
Bearing				
359.9	343.19	0.849	D16	
0	24	0.111	5.09	
Transfer				
351.3	67.03	0.111	D16	
765.7	24	0.111	24.00	
Critical				
337.4	54.98	0.111	D16	
1892.2	24	0.111	24.00	
0.1L				
300.1	47.36	0.111	D16	
4823.7	24	0.111	24.00	
0.2L				
240	7.91	0.111	D16	
8593.2	24	0.111	24.00	
0.3L				
181.1	0	0.111	D16	
11122.1	24	0.111	24.00	
0.4L				
123.6	0	0.111	D16	
12467.8	24	0.111	24.00	
0.5L				
67.3	0	0.111	D16	
12687.4	24	0.111	24.00	

Table B-5 Reinforcement required to meet anchorage zone splitting resistance for the modified BT girder

Splitting Resistance			
Pr (kips)	98.43	As (in ²)	4.92
f _s (ksi)	20	h/4 (in)	18.5
5 U D60s @		4 in	

Table B-6 Required interface shear reinforcement for the modified BT girder

Interface Shear Resistance						
Vu (kips)	dp (in)	dv (in)	vui (ksi)	Vni RQ (K/ft)	Avf (in ² /ft)	Avfmin (in ² /ft)
Bearing	0					
183.2	58.85	54.23	0.08	45.04	0	0
Transfer	2.29					
179.5	59.42	54.79	0.07	43.68	0	0
Critical	5.99					
173.5	60.33	55.71	0.07	41.53	0	0
0.1L	15.95					
157.5	62.79	58.16	0.06	36.11	0	0
0.2L	32.60					
133	66.89	62.27	0.05	28.48	0	0
0.3L	49.26					
109.9	71.00	66.37	0.04	22.08	0	0
0.4L	65.91					
87.9	75.11	70.48	0.03	16.63	0	0
0.5L	82.57					
67.3	75.11	70.48	0.02	12.73	0	0
For concrete placed against a clean concrete surface, free of laitance intentionally roughened						
bvi		44	in	K1	0.2	
c		0.28	ksi	K2	0.8	
μ		1		fty	60	ksi

AASHTO TYPE III

Table B-7 Geometric and basic material properties of the AASHTO Type III girder

Geometric and Material Properties								
h	45	in	dts HDP	17	in	f'c deck	4	ksi
htotal/2	27.375	in	dts end	41	in	E deck	4949	ksi
Act	352.88	in ²	dp crit.	43.04	in	b deck	76.75	in
Ec	6220.7	ksi	dp HDP	47.18	in	t deck	7	in
Strands	42		HDP	35	ft	t Haunch	2.75	in
Draped Strands	8		α1	0.85		b Haunch	16	in
Aps 1strand	0.153		β1	0.85		b top	16	in
fpu	270	ksi	fpe	172.2	ksi	t top	7	in
Strand dia.	0.5	in	Eps	28500	ksi	bw	7	in
f'c	8	ksi	fps	198.29	ksi	Ldev	66.79	in
fty	60	ksi				Ltransfer	30	in

Table B-8 Finding the depth of the effective compression block for the AASHTO Type III girder

Bearing			Transfer			Critical		
Aps (in ²)	1.64		Aps (in ²)	4.12		Ldev (in)	122.6	
etop	0.003		etop	0.003		Aps (in ²)	4.36	
c (in)	2.00		c (in)	4.24		etop	0.003	
dp (in)	42.74		dp (in)	42.93		c (in)	5.27	
epo	0.003		epo	0.007		dp (in)	43.04	
eps	0.061		eps	0.027		epo	0.007	
epps	0.064		epps	0.034		eps	0.021	
fps (ksi)	269		fps (ksi)	269		epps	0.028	
T (kips)	443	t	T (kips)	1107	t	fps (ksi)	268	
C1 (kips)	443	1.70	C1 (kips)	1107	4.24	T (kips)	1169	t
C2 (kips)	0	0	C2 (kips)	0	0	C1 (kips)	1169	4.48
C3 (kips)	0	0	C3 (kips)	0	0	C2 (kips)	0	0
C4 (kips)	0	0	C4 (kips)	0	0	C3 (kips)	0	0
C6 (kips)	0	0	C6 (kips)	0	0	C4 (kips)	0	0
T-C (kips)	0		T-C (kips)	0		C6 (kips)	0	0
	a (in)	1.70		a (in)	4.24	T-C (kips)	0	
	c (in)	2.00		c (in)	4.99		a (in)	4.48
							c (in)	5.27

0.1L			0.2L			0.3L		
Ldev (in)	122.0		etop	0.003		etop	0.003	
Aps (in ²)	6.08		c (in)	7.74		c (in)	7.744	
etop	0.003		dp (in)	44.96		dp (in)	46.13	
c (in)	7.32		epo	0.0066		epo	0.0066	
dp (in)	43.78		eps	0.014		eps	0.015	
epo	0.0066		epps	0.021		epps	0.022	
eps	0.015		fps (ksi)	267		fps (ksi)	267	
epps	0.022		T (kips)	1717	t	T (kips)	1717	t
fps (ksi)	267		C1 (kips)	1717	6.58	C1 (kips)	1717	6.58
T (kips)	1625	t	C2 (kips)	0	0	C2 (kips)	0	0
C1 (kips)	1624	6.23	C3 (kips)	0	0	C3 (kips)	0	0
C2 (kips)	0	0	C4 (kips)	0	0	C4 (kips)	0	0
C3 (kips)	0	0	C6 (kips)	0	0	C6 (kips)	0	0
C4 (kips)	0	0	T-C (kips)	0		T-C (kips)	0	
C6 (kips)	0	0		a (in)	6.58		a (in)	6.58
T-C (kips)	0			c (in)	7.74		c (in)	7.74
	a (in)	6.23						
	c (in)	7.32						

0.4L			At Midspan		
etop	0.003		etop	0.003	
c (in)	7.75		c (in)	7.75	
dp (in)	47.18		dp (in)	47.18	
epo	0.0066		epo	0.0066	
eps	0.015		eps	0.015	
epps	0.022		epps	0.022	
fps (ksi)	267		fps (ksi)	267	
T (kips)	1718	t	T (kips)	1718	t
C1 (kips)	1718	6.58	C1 (kips)	1718	6.58
C2 (kips)	0	0	C2 (kips)	0	0
C3 (kips)	0	0	C3 (kips)	0	0
C4 (kips)	0	0	C4 (kips)	0	0
C6 (kips)	0	0	C6 (kips)	0	0
T-C (kips)	0		T-C (kips)	0	
	a (in)	6.58		a (in)	6.58
	c (in)	7.75		c (in)	7.75

Table B-9 Determining shear angle and beta of the AASHTO Type III girder

Location (ft)		Shear Strength					
Vu (kips)	Strands	bv (in)	de (in)	Aps (in ²)	Vp (kips)	ϵ_s	Θ
Mcor (kft)		a (in)	dv (in)	fpo (ksi)	vu/fc	Vc-com (kips)	β
Bearing	1.0						
231.9	34	7	48.69	1.81	4.81	6.00E-03	50
0		1.70	47.84	75.6	0.094	26.12	0.87
Transfer	2.5						
225.4	34	7	48.69	5.202	12.02	-2.37E-04	28.17
346.2		4.24	46.57	189	0.091	170.16	5.84
Critical	3.3						
222.1	34	7	48.69	5.20	12.02	-2.40E-04	28.16
520.4		4.48	46.45	189	0.090	170.16	5.86
0.1L	9.0						
197.6	34	7	48.69	5.20	12.02	-1.53E-04	28.46
1667.4		6.23	45.58	189	0.081	154.62	5.42
0.2L	18.0						
161.5	40	7	45.90	6.12	12.02	-6.65E-05	28.77
3017.1		6.58	42.61	189	0.070	134.69	5.05
0.3L	27.0						
126.5	42	7	46.13	6.43	12.02	-4.21E-07	29.00
3923.9		6.58	42.84	189	0.054	128.70	4.80
0.4L	36.0						
92.3	42	7	47.18	6.43	0.00	4.10E-04	30.43
4378.6		6.58	43.89	189	0.042	100.82	3.67
0.5L	45.0						
58.8	42	7	47.18	6.43	0.00	2.61E-04	29.91
4401.2		6.58	43.89	189	0.027	110.25	4.02

Table B-10 Required stirrups for shear strength at 60 ksi design yield strength for the AASHTO Type III girder

Location (ft)		Shear Strength (ft _y = 60 ksi)		
Vu (kips)	Vs reqd (kips)	Av/s (in ² /ft) min Av/s	Size	
Mcor (kft)	Max spc (in)	(in ² /ft)	Spacing (in)	
Bearing				
231.9	226.73	1.13	D20	
0	24	0.125		4.25
Transfer				
225.4	68.259	0.157	D20	
346.2	24	0.125		24
Critical				
222.1	64.591	0.149	D20	
520.4	24	0.125		24
0.1L				
197.6	52.907	0.126	D20	
1667.4	24	0.125		24
0.2L				
161.5	32.733	0.125	D20	
3017.1	24	0.125		24
0.3L				
126.5	0	0.125	D20	
3923.9	24	0.125		24
0.4L				
92.3	1.739	0.125	D20	
4378.6	24	0.125		24
0.5L				
58.8	0	0.125	D20	
4401.2	24	0.125		

Table B-11 Required stirrups for shear strength at 75 ksi design yield strength for the AASHTO Type III girder

Location (ft)		Shear Strength (ft _y = 75 ksi)		
Vu (kips)	Vs reqd (kips)	Av/s (in ² /ft)	Size	
Mcor (kft)	Max spc (in)	min Av/s (in ² /ft)	Spacing (in)	
Bearing				
231.9	226.73	0.90	D16	
0	24	0.100		4.25
Transfer				
225.4	68.259	0.126	D16	
346.2	24	0.100		24
Critical				
222.1	64.591	0.119	D16	
520.4	24	0.100		24
0.1L				
197.6	52.907	0.101	D16	
1667.4	24	0.100		24
0.2L				
161.5	32.733	0.100	D16	
3017.1	24	0.100		24
0.3L				
126.5	0	0.100	D16	
3923.9	24	0.100		24
0.4L				
92.3	1.739	0.100	D16	
4378.6	24	0.100		24
0.5L				
58.8	0	0.100	D16	
4401.2	24	0.100		24

Table B-12 Reinforcement required to meet anchorage zone splitting resistance for the AASHTO Type III girder

Splitting Resistance			
Pr (kips)	52.05	As (in ²)	2.60
fs (ksi)	20	h/4 (in)	11.25
3 U D45 @ 4 in			

Table B-13 Required interface shear reinforcement for the AASHTO Type III girder

Interface Shear Resistance						
Vu (kips)	dp (in)	dv (in)	vui (ksi)	Vni RQ (K/ft)	Avf (in ² /ft)	Avfmin (in ² /ft)
Bearing	1					
156.2	42.74	37.86	0.26	55.01	0.02	0.16
Transfer	2.5					
152.3	42.93	38.06	0.25	53.36	0.00	0.16
Critical	3.28					
150.3	43.04	38.16	0.25	52.51	0.00	0.16
0.1L	9					
135.6	43.78	38.91	0.22	46.47	0.00	0.00
0.2L	18					
114.1	44.96	40.08	0.18	37.95	0.00	0.00
0.3L	27					
92.6	46.13	41.26	0.14	29.93	0.00	0.00
0.4L	36					
63.7	47.18	42.30	0.09	20.08	0.00	0.00
0.5L	45					
42.2	47.18	42.30	0.06	13.30	0.00	0.00
For concrete placed against a clean concrete surface, free of laitance intentionally roughened						
bvi	44	in	K1	0.2		
c	0.28	ksi	K2	0.8		
μ	1		fty	60	ksi	

BT-72

Table B-14 Geometric and basic material properties of the BT-72 girder

Geometric and Material Properties					
h	72 in	dts HDP	14.5 in	f'c deck	4 ksi
htotal/2	40.625 in	dts end	66.5 in	E deck	4949 ksi
Act	408.75 in ²	dp crit.	65.63 in	b deck	76.75 in
Ec	6090 ksi	dp HDP	75.25 in	t deck	7 in
Strands	40	HDP	54 ft	t Haunch	2.25 in
Draped Strands	8	α1	0.85	b Haunch	42 in
Aps 1strand	0.217	β1	0.85	b top	42 in
fpu	270 ksi	fpe	172.2 ksi	t top	3.5 in
Strand dia.	0.6 in	Eps	28500 ksi	bw	6 in
f'c	8 ksi	fps	198 ksi	Ldev	80.2 in
fty	60 ksi			Ltransfer	36 in

Table B-15 Finding the depth of the effective compression block for the BT-72 girder

Bearing			Transfer			Critical		
Aps (in ²)	1.1084		Aps (in ²)	5.5679		Ldev (in)	147.4	
etop	0.003		etop	0.003		Aps (in ²)	5.9152	
c (in)	1.35		c (in)	6.74		etop	0.003	
dp (in)	64.966		dp (in)	65.428		c (in)	7.16	
epo	0.0013		epo	0.0066		dp (in)	65.626	
eps	0.1414		eps	0.0261		epo	0.0066	
epps	0.1427		epps	0.0328		eps	0.0245	
fps (ksi)	269.71		fps (ksi)	268.45		epps	0.0311	
T (kips)	298.94	t	T (kips)	1494.7	t	fps (ksi)	268.34	
C1 (kips)	298.94	1.15	C1 (kips)	1494.7	5.73	T (kips)	1587.3	t
C2 (kips)	0	0	C2 (kips)	0	0	C1 (kips)	1587.3	6.08
C3 (kips)	0	0	C3 (kips)	0	0	C2 (kips)	0	0
C4 (kips)	0	0	C4 (kips)	0	0	C3 (kips)	0	0
C6 (kips)	0	0	C6 (kips)	0	0	C4 (kips)	0	0
T-C (kips)	0		T-C (kips)	0		C6 (kips)	0	0
	a (in)	1.15		a (in)	5.73	T-C (kips)	0	
	c (in)	1.35		c (in)	6.74		a (in)	6.08
							c (in)	7.16

0.1L			0.2L			0.3L		
etop	0.003		etop	0.003		etop	0.003	
c (in)	11.59		c (in)	11.59		c (in)	11.594	
dp (in)	67.435		dp (in)	70.019		dp (in)	72.604	
epo	0.0066		epo	0.0066		epo	0.0066	
eps	0.0145		eps	0.0151		eps	0.0158	
epps	0.0211		epps	0.0218		epps	0.0224	
fps (ksi)	267.16		fps (ksi)	267.29		fps (ksi)	267.41	
T (kips)	2319	t	T (kips)	2320.1	t	T (kips)	2321.1	t
C1 (kips)	1826.7	7	C1 (kips)	1826.7	7	C1 (kips)	1826.7	7
C2 (kips)	321.3	2.25	C2 (kips)	321.3	2.25	C2 (kips)	321.3	2.25
C3 (kips)	171.36	0.60	C3 (kips)	171.65	0.601	C3 (kips)	172.79	0.605
C4 (kips)	0	0	C4 (kips)	0	0	C4 (kips)	0	0
C6 (kips)	0	0	C6 (kips)	0	0	C6 (kips)	0	0
T-C (kips)	0		T-C (kips)	0		T-C (kips)	0	
	a (in)	9.85		a (in)	9.851		a (in)	9.855
	c (in)	11.588		c (in)	11.589		c (in)	11.594

0.4L			0.5L		
etop	0.003		etop	0.003	
c (in)	11.6		c (in)	11.6	
dp (in)	75.188		dp (in)	75.25	
epo	0.0066		epo	0.0066	
eps	0.0164		eps	0.0165	
epps	0.0231		epps	0.0231	
fps (ksi)	267.51		fps (ksi)	267.51	
T (kips)	2322	t	T (kips)	2322	t
C1 (kips)	1826.7	7	C1 (kips)	1826.7	7
C2 (kips)	321.3	2.25	C2 (kips)	321.3	2.25
C3 (kips)	174.22	0.61	C3 (kips)	174.22	0.61
C4 (kips)	0	0	C4 (kips)	0	0
C6 (kips)	0	0	C6 (kips)	0	0
T-C (kips)	0		T-C (kips)	0	
	a (in)	9.86		a (in)	9.86
	c (in)	11.6		c (in)	11.6

Table B-16 Determining shear angle and beta of the BT-72 girder

Location (ft)		Shear Strength						
Vu (kips)	Strands	bv (in)	de (in)	Aps (in ²)	Vp (kips)	εs	Θ	
Mcor (kft)		a (in)	dv (in)	fpo (ksi)	vu/fc	Vc-com (kips)	β	
Bearing	0.6							
319.7	32	6	76.63	1.21	4.78	6.00E-03	50	
0		1.15	76.05	37.8	0.096	35.59	0.87	
Transfer	3.0							
310.1	32	6	76.63	6.944	23.91	-2.75E-04	28.04	
745.2		5.73	73.76	189	0.091	239.30	6.05	
Critical	4.0							
306	32	6	76.63	6.94	23.91	-2.78E-04	28.03	
1056.2		6.08	73.58	189	0.089	239.41	6.07	
0.1L	13.4							
268.2	32	6	76.63	6.94	23.91	-1.72E-04	28.40	
3619.3		9.85	71.70	189	0.080	211.91	5.51	
0.2L	26.8							
216.5	38	6	71.57	8.25	23.91	-7.57E-05	28.74	
6441		9.85	66.64	189	0.068	181.86	5.09	
0.3L	40.3							
165.9	40	6	72.60	8.68	23.91	-8.73E-06	28.97	
8316.5		9.86	67.68	189	0.049	175.35	4.83	
0.4L	53.7							
116.4	40	6	75.19	8.68	0.00	2.54E-04	29.89	
9291		9.86	70.26	189	0.038	151.94	4.03	
0.5L	67.1							
68	40	6	75.25	8.68	0.00	1.34E-04	29.47	
9409.2		9.86	70.32	189	0.022	164.48	4.36	

Table B-17 Required stirrups for shear strength at 60 ksi design yield strength for the BT-72 girder

Location (ft)		Shear Strength (ft _y = 60ksi)		
Vu (kips)	Vs reqd (kips)	Av/s (in ² /ft)	Size	
Mcor (kft)	Max spc (in)	min Av/s (in ² /ft)	Spacing (in)	
Bearing				
319.7	314.85	0.99	D45	
0	24	0.107		4.86
Transfer				
310.1	81.347	0.117	D20	
745.2	24	0.107		24
Critical				
306	76.676	0.111	D20	
1056.2	24	0.107		24
0.1L				
268.2	62.176	0.107	D20	
3619.3	24	0.107		24
0.2L				
216.5	34.78	0.107	D20	
6441	24	0.107		24
0.3L				
165.9	0	0.107	D20	
8316.5	24	0.107		24
0.4L				
116.4	0	0.107	D20	
9291	24	0.107		24
0.5L				
68	0	0.107	D20	
9409.2	24	0.107		24

Table B-18 Required stirrups for shear strength at 75 ksi design yield strength for the BT-72 girder

Location (ft)		Shear Strength (ft _y = 75ksi)		
Vu (kips)	Vs reqd (kips)	Av/s (in ² /ft)	Size	
Mcor (kft)	Max spc (in)	min Av/s (in ² /ft)	Spacing (in)	
Bearing				
319.7	314.85	0.79	D16	
0	24	0.086	4.86	
Transfer				
310.1	81.347	0.094	D16	
745.2	24	0.086	24	
Critical				
306	76.676	0.089	D16	
1056.2	24	0.086	24	
0.1L				
268.2	62.176	0.086	D16	
3619.3	24	0.086	24	
0.2L				
216.5	34.78	0.086	D16	
6441	24	0.086	24	
0.3L				
165.9	0	0.086	D16	
8316.5	24	0.086	24	
0.4L				
116.4	0	0.086	D16	
9291	24	0.086	24	
0.5L				
68	0	0.086	D16	
9409.2	24	0.086	24	

Table B-19 Reinforcement required to meet anchorage zone splitting resistance for the BT-72 girder

Splitting Resistance			
Pr (kips)	70.31	As (in ²)	3.52
fs (ksi)	20	h/4 (in)	18
5 U D45 @ 5 in			

Table B-20 Required interface shear reinforcement for the BT-72 girder

Interface Shear Resistance						
Vu (kips)	dp (in)	dv (in)	vui (ksi)	Vni RQ (K/ft)	Avf (in ² /ft)	Avfmin (in ² /ft)
Bearing	0.6					
183.2	64.97	60.34	0.07	40.48	0.07	0.00
Transfer	3					
178.5	65.43	60.80	0.07	39.14	0.04	0.00
Critical	4.03					
176.5	65.63	61.00	0.07	38.58	0.02	0.00
0.1L	13.42					
157.9	67.43	62.81	0.06	33.52	0.00	0.00
0.2L	26.84					
133.9	70.02	65.39	0.05	27.30	0.00	0.00
0.3L	40.26					
110.7	72.60	67.98	0.04	21.71	0.00	0.00
0.4L	53.68					
88.8	75.19	70.56	0.03	16.78	0.00	0.00
0.5L	67.1					
68	75.25	70.63	0.02	12.84	0.00	0.00
For concrete placed against a clean concrete surface, free of laitance intentionally roughened						
bvi	44	in	K1	0.2		
c	0.28	ksi	K2	0.8		
μ	1		fty	60	ksi	

Modified AASHTO Type I

Table B-21 Geometric and basic material properties of the Modified AASHTO Type I

Geometric and Material Properties					
h	30 in	dts HDP	10.5 in	f'c deck	4 ksi
htotal/2	19.75 in	dts end	24 in	E deck	4949 ksi
Act	378.5 in ²	dp crit.	32.58 in	b deck	72.75 in
Ec	6221 ksi	dp HDP	33.952 in	t deck	7 in
Strands	42	HDP	27.6 ft	t Haunch	2.5 in
Draped Strands	6	α_1	0.85	b Haunch	22 in
Aps 1strand	0.167 in ²	β_1	0.85	b top	22 in
Strand dia.	0.5 in	fpe	184 ksi	t top	4 in
fpu	270 ksi	Eps	28500 ksi	bw	11 in
f'c	8 ksi	fps	256 ksi	Ldev	106.7 in
fty	60 ksi			Ltransfer	30 in

Table B-22 Determining shear angle and beta of the Modified AASHTO Type I

Location (ft)		Shear Strength						
Vu (kips)	Strands	bv (in)	de (in)	Aps (in ²)	Vp (kips)	ϵ_s Vc-com (kips)	Θ	
Mcor (kft)		a (in)	dv (in)	fpo (ksi)	vu/fc		β	
Bearing	0.6							
225.9	32	11	34.25	0.92	1.80	6.00E-03	50	
0		1.19	33.66	45.36	0.084	28.88	0.87	
Transfer	2.5							
217.2	34	11	33.45	4.08106	7.51	-1.03E-04	28.64	
422.9		4.88	31.01	189	0.086	158.67	5.20	
Critical	3.2							
214	34	11	33.47	4.25	7.51	-1.12E-04	28.61	
556		5.13	30.91	189	0.085	159.21	5.24	
0.1L	7.9							
192.5	38	11	33.04	6.02	7.51	-1.03E-04	28.64	
1480.3		6.83	29.74	189	0.079	152.02	5.20	
0.2L	15.8							
158.5	42	11	33.13	7.01	7.51	-3.43E-05	28.88	
2621.2		10.09	29.82	189	0.064	144.43	4.93	
0.3L	23.8							
125.4	42	11	33.68	7.01	7.51	6.48E-04	31.27	
3378.6		10.18	30.32	189	0.049	96.26	3.23	
0.4L	31.7							
92.9	42	11	33.95	7.01	0.00	1.19E-03	33.16	
3744.3		10.18	30.56	189	0.038	76.23	2.54	
0.5L	39.6							
61.2	42	11	33.95	7.01	0.00	1.01E-03	32.54	
3735.3		10.18	30.56	189	0.025	81.96	2.73	

Table B-23 Required stirrups for shear strength at 60 ksi design yield strength for the Modified AASHTO Type I

Location (ft)		Shear Strength (ft _y = 60ksi)		
Vu (kips)	Vs reqd (kips)	Av/s (in ² /ft)	Size	
Mcor (kft)	Max spc (in)	min Av/s (in ² /ft)	Spacing (in)	
Bearing				
225.9	220.32	1.56	D20	
0	24	0.197		3.08
Transfer				
217.2	75.159	0.265	D20	
422.9	24	0.197		18
Critical				
214	71.055	0.251	D20	
556	24	0.197		19
0.1L				
192.5	54.361	0.200	D20	
1480.3	23	0.197		23
0.2L				
158.5	24.168	0.197	D20	
2621.2	23	0.197		23
0.3L				
125.4	35.569	0.197	D20	
3378.6	24	0.197		24
0.4L				
92.9	26.992	0.197	D20	
3744.3	24	0.197		24
0.5L				
61.2	0	0.197	D20	
3735.3	24	0.197		24

Table B-24 Required stirrups for shear strength at 60 ksi design yield strength for the Modified AASHTO Type I

Location (ft)		Shear Strength (ft _y = 75ksi)		
V _u (kips)	V _s reqd (kips)	Av/s (in ² /ft)	Size	
M _{cor} (kft)	Max spc (in)	min Av/s (in ² /ft)	Spacing (in)	
Bearing				
225.9	220.32	1.25	D16	
0	24	0.157		3.08
Transfer				
217.2	75.159	0.212	D16	
422.9	24	0.157		18
Critical				
214	71.055	0.201	D16	
556	24	0.157		19
0.1L				
192.5	54.361	0.160	D16	
1480.3	23	0.157		13
0.2L				
158.5	24.168	0.157	D16	
2621.2	23	0.157		23
0.3L				
125.4	35.569	0.157	D16	
3378.6	24	0.157		24
0.4L				
92.9	26.992	0.157	D16	
3744.3	24	0.157		24
0.5L				
61.2	0	0.157	D16	
3735.3	24	0.157		24

Table B-25 Reinforcement required to meet anchorage zone splitting resistance for the Modified AASHTO Type I

Splitting Resistance			
Pr (kips)	56.81	As (in ²)	2.84
fs (ksi)	20	h/4 (in)	9.875
3 U D60 @		4 in	

Table B-26 Required interface shear reinforcement for the Modified AASHTO Type I

Interface Shear Resistance						
Vu (kips)	dp (in)	dv (in)	vui (ksi)	Vni RQ (K/ft)	Avf (in ² /ft)	Avfmin (in ² /ft)
Bearing	0.6					
225.9	31.65	26.90	0.38	111.96	0.63	0.22
Transfer	2.5					
217.2	31.80	27.05	0.37	107.07	0.55	0.22
Critical	3.18					
214.1	31.85	27.10	0.36	105.33	0.52	0.22
0.1L	7.92					
192.5	32.36	27.61	0.32	92.97	0.32	0.22
0.2L	15.84					
158.5	33.13	28.38	0.25	74.46	0.01	0.22
0.3L	23.76					
125.4	33.68	28.93	0.20	57.79	0.00	0.05
0.4L	31.68					
92.9	33.95	29.20	0.14	42.42	0.00	0.00
0.5L	39.6					
61.2	33.95	29.20	0.10	27.94	0.00	0.00
For concrete placed against a clean concrete surface, free of laitance intentionally roughened						
bvi	44	in	K1	0.2		
c	0.28	ksi	K2	0.8		
μ	1		fty	60	ksi	